

TK717XX

LDO, $I_O=200\text{mA}$, Bipolar, Auto Discharge
 LDOレギュレータ、 $I_O=200\text{mA}$ 、バイポーラ、自動ディスチャージ



Feature

- | | |
|---|---|
| ■ Auto discharge function | ■ 自動ディスチャージ機能 |
| ■ High accuracy | ■ 高い出力電圧精度 |
| ■ Low dropout voltage | ■ 低い入出力間電圧降下 |
| ■ Thermal and over current protection | ■ 過電流保護、過熱保護 |
| ■ Built-in reverse bias over current protection | ■ 逆バイアス過電流阻止回路 |
| ■ Active high on/off control | ■ アクティブハイ on/off コントロール |
| ■ Packages: SOT23-5 | ■ パッケージ: SOT23-5 |
| ■ Operating Voltage Range $V_{OP}=2.1$ to 14V | ■ 動作電圧範囲 $V_{OP}=2.1\sim 14\text{V}$ |
| ■ Operating Temp. Range $T_{OP}=-40$ to $+85^\circ\text{C}$ | ■ 動作温度範囲 $T_{OP}=-40\sim +85^\circ\text{C}$ |

Electrical Characteristics

Part Name	Ch	V_{OP}	V_{OUT}	I_{OUT}	V_{DROP}	Package	I_Q	R.R.
TK717XX	1ch	2.1 to 14V	1.5 to 5V	200 mA	163mV	SOT23-5	72 μA	-80dB

Ordering Guide, Marking

Part Name	Ordering Name	Marking	Description	Order Size
TK717XX	TK717**SCL-G		TK717**: Part Name M: SOT23-5 Package C: $T_A=+25^\circ\text{C}$ L: Tape&Reel, Left -G: PB-Free	3,000 pcs./Reel
TK717XX	TK717**SIL-G		TK717**: Part Name S: SOT23-5 Package I: $T_A=-40$ to $+85^\circ\text{C}$ L: Tape&Reel, Left -G: PB-Free	3,000 pcs./Reel

* ***, in ordering name, means voltage code. For example, "33" shows 3.3V.
 オーダリング名中の***は電圧コードを示しています。例えば"33"は3.3Vを示します。

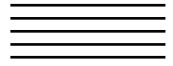

Pin Layout, Block Diagram

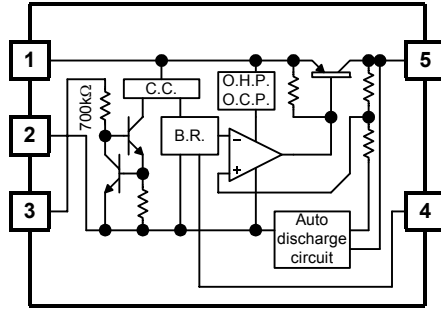

LDO, Positive I/O, Bipolar 6

Looking for pricing, stock, or lifecycle information?

Click below to explore more details on WIN SOURCE:

- [View TK71750SCL-G on WIN SOURCE](#)
- [Toko America Inc. Information](#)

Optimize Your Supply Chain with WIN SOURCE Solutions

- ✓ Global Sourcing Solution
- ✓ Obsolete Management
- ✓ Cost Control Management
- ✓ Shortage Management
- ✓ Alternative Solution
- ✓ Excess Inventory Management