



**THE DATASHEET OF  
TL16C550BPT**



- Capable of Running With All Existing TL16C450 Software
- After Reset, All Registers Are Identical to the TL16C450 Register Set
- In the FIFO Mode, Transmitter and Receiver Are Each Buffered With 16-Byte FIFOs to Reduce the Number of Interrupts to the CPU
- In the TL16C450 Mode, Hold and Shift Registers Eliminate the Need for Precise Synchronization Between the CPU and Serial Data
- Programmable Baud Rate Generator Allows Division of Any Input Reference Clock by 1 to  $(2^{16} - 1)$  and Generates an Internal  $16 \times$  Clock
- Standard Asynchronous Communication Bits (Start, Stop, and Parity) Added to or Deleted From the Serial Data Stream
- Independent Receiver Clock Input
- Transmit, Receive, Line Status, and Data Set Interrupts Independently Controlled
- Fully Programmable Serial Interface Characteristics:
  - 5-, 6-, 7-, or 8-Bit Characters
  - Even-, Odd-, or No-Parity Bit Generation and Detection
  - 1-, 1 1/2-, or 2-Stop Bit Generation
  - Baud Generation (DC to 562 Kbit/s)
- False-Start Bit Detection
- Complete Status Reporting Capabilities
- 3-State Outputs Provide TTL Drive Capabilities for Bidirectional Data Bus and Control Bus
- Line Break Generation and Detection
- Internal Diagnostic Capabilities:
  - Loopback Controls for Communications Link Fault Isolation
  - Break, Parity, Overrun, Framing Error Simulation
- Fully Prioritized Interrupt System Controls
- Modem Control Functions ( $\overline{\text{CTS}}$ ,  $\overline{\text{RTS}}$ ,  $\overline{\text{DSR}}$ ,  $\overline{\text{DTR}}$ ,  $\overline{\text{RI}}$ , and  $\overline{\text{DCD}}$ )
- Faster Plug-In Replacement for National Semiconductor NS16550A

## description

The TL16C550B and the TL16C550BI are functional upgrades of the TL16C450 asynchronous communications element (ACE). Functionally identical to the TL16C450 on power up (character mode†), the TL16C550B and TL16C550BI can be placed in an alternate mode (FIFO) to relieve the CPU of excessive software overhead.

In this alternate FIFO mode, internal FIFOs are activated allowing 16 bytes (plus 3 bits of error data per byte in the receiver FIFO) to be stored in both receive and transmit modes. To minimize system overhead and maximize system efficiency, all logic is on the chip. Two of the TL16C450 terminal functions ( $\overline{\text{RXRDY}}$  and  $\overline{\text{TXRDY}}$ ) have been changed to allow signalling of DMA transfers.

The TL16C550B and the TL16C550BI perform serial-to-parallel conversions on data received from a peripheral device or modem and parallel-to-serial conversion on data received from its CPU. The CPU can read and report on the status of the ACE at any point in the ACE operation. Reported status information includes: the type of transfer operation in progress, the status of the operation, and any error conditions encountered.



Please be aware that an important notice concerning availability, standard warranty, and use in critical applications of Texas Instruments semiconductor products and disclaimers thereto appears at the end of this data sheet.

† The TL16C550B and the TL16C550BI can also be reset to the TL16C450 mode under software control.

PRODUCTION DATA information is current as of publication date. Products conform to specifications per the terms of Texas Instruments standard warranty. Production processing does not necessarily include testing of all parameters.



POST OFFICE BOX 655303 • DALLAS, TEXAS 75265

Copyright © 1996, Texas Instruments Incorporated

# TL16C550B, TL16C550BI ASYNCHRONOUS COMMUNICATIONS ELEMENT

SLLS136B – JANUARY 1994 – REVISED AUGUST 1996

---

## **description (continued)**

The TL16C550B and the TL16C550BI ACE include programmable, on-board, baud rate generators. These generators are capable of dividing a reference clock input by divisors from 1 to  $(2^{16} - 1)$  and producing a  $16\times$  clock for driving the internal transmitter logic. Provisions are included to use this  $16\times$  clock to drive the receiver logic. Also included in the ACE is a complete modem control capability and a processor interrupt system that may be software tailored to user requirements to minimize the computing required to handle the communications link.

The TL16C550B is available in a 40-pin DIP (N) package, 44-pin PLCC (FN) package, and 48-pin TQFP (PT) package. The TL16C550BI is available in a 44-pin PLCC (FN) package.



POST OFFICE BOX 655303 • DALLAS, TEXAS 75265

# TL16C550B, TL16C550BI ASYNCHRONOUS COMMUNICATIONS ELEMENT

SLLS136B – JANUARY 1994 – REVISED AUGUST 1996

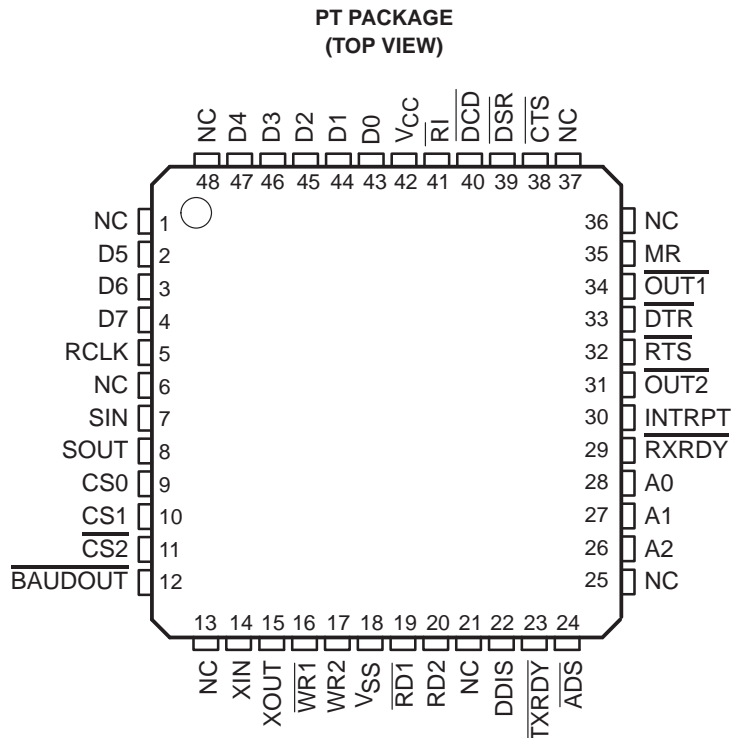
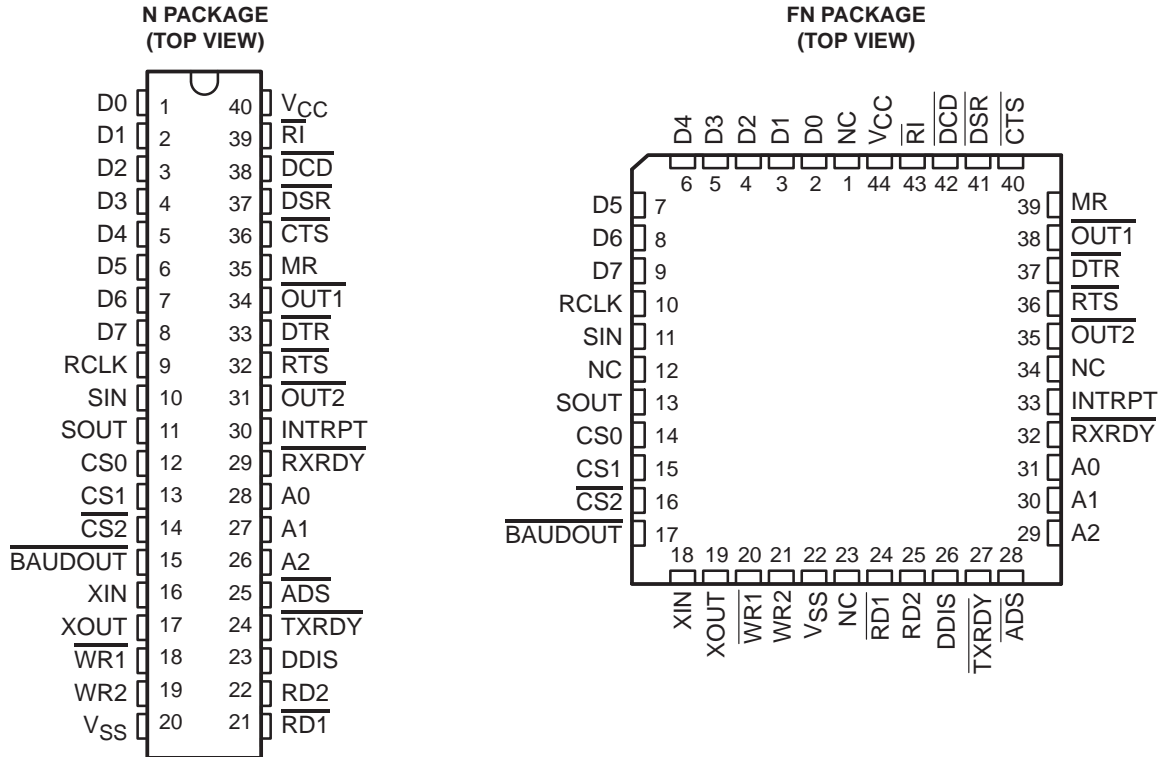

NC—No internal connection

# TL16C550B, TL16C550BI ASYNCHRONOUS COMMUNICATIONS ELEMENT

SLLS136B – JANUARY 1994 – REVISED AUGUST 1996

## functional block diagram

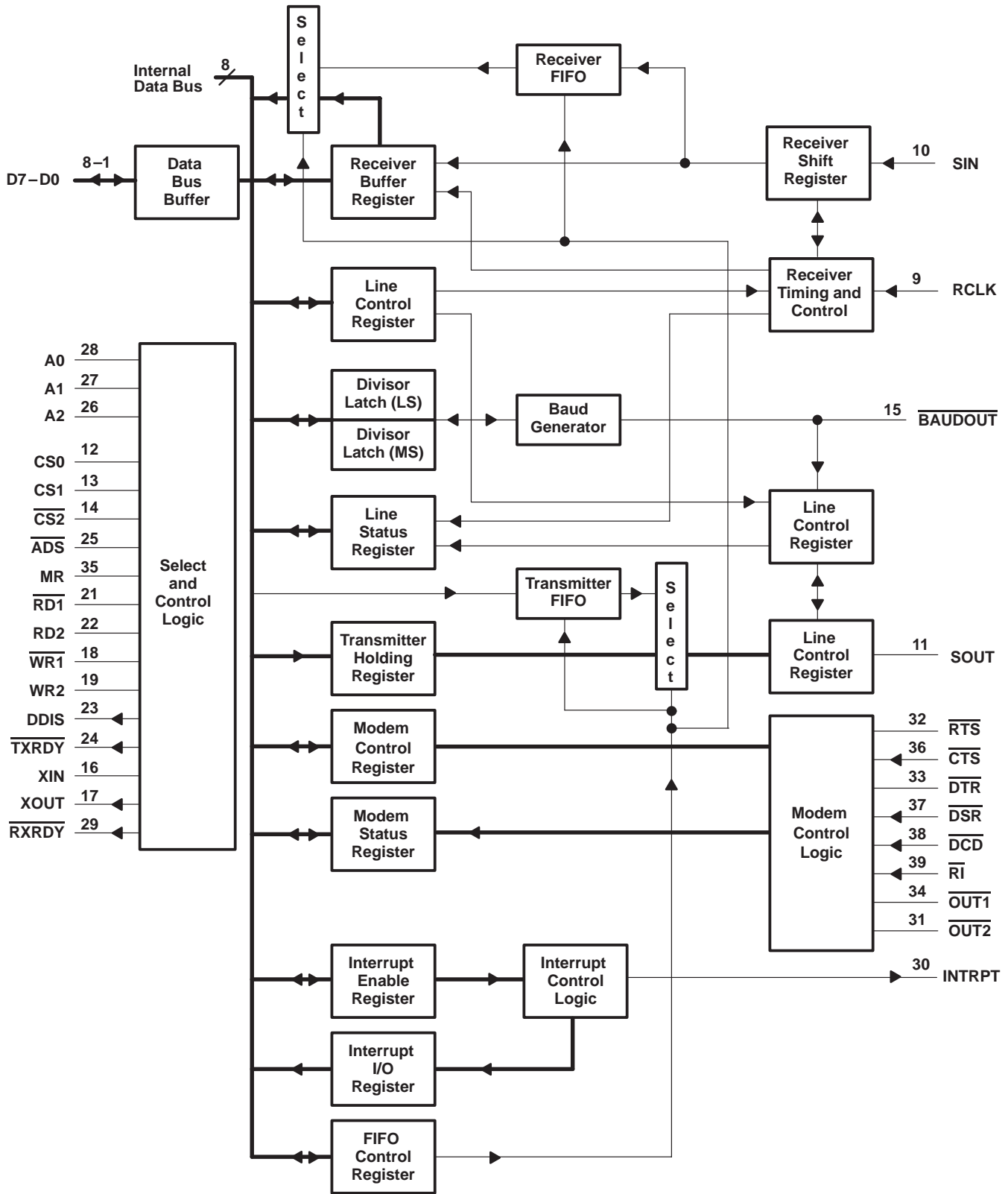

Terminal numbers shown are for the N package.



POST OFFICE BOX 655303 • DALLAS, TEXAS 75265

# TL16C550B, TL16C550BI ASYNCHRONOUS COMMUNICATIONS ELEMENT

SLLS136B – JANUARY 1994 – REVISED AUGUST 1996

## Terminal Functions

TERMINAL				I/O	DESCRIPTION
NAME	NO. N	NO. FN	NO. PT		
A0 A1 A2	28 27 26	31 30 29	28 27 26	I	Register select. A0–A2 are used during read and write operations to select the ACE register to read from or write to. Refer to Table 1 for register addresses, and refer to the address strobe (ADS) signal description.
ADS	25	28	24	I	Address strobe. When $\overline{\text{ADS}}$ is active (low), the register select signals (A0, A1, and A2) and chip select signals (CS0, CS1, $\overline{\text{CS2}}$ ) drive the internal select logic directly; when high, the register select and chip select signals are held in the state they are in when the low-to-high transition of ADS occurs.
BAUDOUT	15	17	12	O	Baud out. BAUDOUT is a 16× clock signal for the transmitter section of the ACE. The clock rate is established by the reference oscillator frequency divided by a divisor specified by the baud generator divisor latches. BAUDOUT can also be used for the receiver section by tying this output to RCLK.
CS0 CS1 CS2	12 13 14	14 15 16	9 10 11	I	Chip select. When CS0 = high, CS1 = high, and $\overline{\text{CS2}}$ = low, these three inputs select the ACE. When any of these inputs are inactive, the ACE remains inactive. Refer to the ADS signal description.
CTS	36	40	38	I	Clear to send. CTS is a modem status signal. Its condition can be checked by reading bit 4 (CTS) of the modem status register. Bit 0 ( $\Delta\text{CTS}$ ) of the modem status register indicates that this signal has changed states since the last read from the modem status register. If the modem status interrupt is enabled when CTS changes state, an interrupt is generated.
D0 D1 D2 D3 D4 D5 D6 D7	1 2 3 4 5 6 7 8	2 3 4 5 6 7 8 9	43 44 45 46 47 2 3 4	I/O	Data bus. Eight data lines with 3-state outputs provide a bidirectional path for data, control, and status information between the ACE and the CPU.
DCD	38	42	40	I	Data carrier detect. DCD is a modem status signal. Its condition can be checked by reading bit 7 (DCD) of the modem status register. Bit 3 ( $\Delta\text{DCD}$ ) of the modem status register indicates that this signal has changed states since the last read from the modem status register. If the modem status interrupt is enabled when DCD changes state, an interrupt is generated.
DDIS	23	26	22	O	Driver disable. This output is active (high) when the CPU is not reading data. When active, this output can disable an external transceiver.
DSR	37	41	39	I	Data set ready. DSR is a modem status signal. Its condition can be checked by reading bit 5 (DSR) of the modem status register. Bit 1 ( $\Delta\text{DSR}$ ) of the modem status register indicates that this signal has changed states since the last read from the modem status register. If the modem status interrupt is enabled when DSR changes state, an interrupt is generated.
DTR	33	37	33	O	Data terminal ready. When active (low), $\overline{\text{DTR}}$ informs a modem or data set that the ACE is ready to establish communication. $\overline{\text{DTR}}$ is placed in the active state by setting the DTR bit of the modem control register to a high level. DTR is placed in the inactive state either as a result of a master reset, during loop mode operation, or clearing the DTR bit.
INTRPT	30	33	30	O	Interrupt. When active (high), INTRPT informs the CPU that the ACE has an interrupt to be serviced. Four conditions that cause an interrupt to be issued are: a receiver error, received data is available or timed out (FIFO mode only), the transmitter holding register is empty, or an enabled modem status interrupt. The INTRPT output is reset (deactivated) either when the interrupt is serviced or as a result of a master reset.
MR	35	39	35	I	Master reset. When active (high), MR clears most ACE registers and sets the state of various output signals. Refer to Table 2.
$\overline{\text{OUT1}}$ $\overline{\text{OUT2}}$	34 31	38 35	34 31	O	Outputs 1 and 2. User-designated outputs that are set to their active low states by setting their respective modem control register bits (OUT1 and OUT2) high. $\overline{\text{OUT1}}$ and $\overline{\text{OUT2}}$ are set to their inactive (high) states as a result of master reset, during loop mode operations, or by clearing bit 2 (OUT1) or bit 3 (OUT2) of the modem control register.
RCLK	9	10	5	I	Receiver clock. RCLK is the 16× baud rate clock for the receiver section of the ACE.

# TL16C550B, TL16C550BI ASYNCHRONOUS COMMUNICATIONS ELEMENT

SLLS136B – JANUARY 1994 – REVISED AUGUST 1996

## Terminal Functions (Continued)

TERMINAL				I/O	DESCRIPTION
NAME	NO. N	NO. FN	NO. PT		
$\overline{RD1}$ RD2	21 22	24 25	19 20	I	Read inputs. When either input is active (low or high respectively) while the ACE is selected, the CPU is allowed to read status information or data from a selected ACE register. Only one of these inputs is required for the transfer of data during a read operation; the other input should be tied in its inactive state (i.e., RD2 tied low or $\overline{RD1}$ tied high).
$\overline{RI}$	39	43	41	I	Ring indicator. $\overline{RI}$ is a modem status signal. Its condition can be checked by reading bit 6 (RI) of the modem status register. Bit 2 (TERI) of the modem status register indicates that the $\overline{RI}$ input has transitioned from a low to a high state since the last read from the modem status register. If the modem status interrupt is enabled when this transition occurs, an interrupt is generated.
$\overline{RTS}$	32	36	32	O	Request to send. When active, $\overline{RTS}$ informs the modem or data set that the ACE is ready to receive data. $\overline{RTS}$ is set to its active state by setting the RTS modem control register bit and is set to its inactive (high) state either as a result of a master reset or during loop mode operations or by clearing bit 1 (RTS) of the MCR.
$\overline{RXRDY}$	29	32	29	O	Receiver ready output. Receiver direct memory access (DMA) signalling is available with this terminal. When operating in the FIFO mode, one of two types of DMA signalling can be selected using the FIFO control register bit 3 (FCR3). When operating in the TL16C450 mode, only DMA mode 0 is allowed. Mode 0 supports single-transfer DMA in which a transfer is made between CPU bus cycles. Mode 1 supports multitransfer DMA in which multiple transfers are made continuously until the receiver FIFO has been emptied. In DMA mode 0 (FCR0 = 0 or FCR0 = 1, FCR3 = 0), when there is at least one character in the receiver FIFO or receiver holding register, $\overline{RXRDY}$ is active low. When $\overline{RXRDY}$ has been active but there are no characters in the FIFO or holding register, $\overline{RXRDY}$ goes inactive (high). In DMA mode 1 (FCR0 = 1, FCR3 = 1), when the trigger level or the timeout has been reached, $\overline{RXRDY}$ goes active (low); when it has been active but there are no more characters in the FIFO or holding register, it goes inactive (high).
SIN	10	11	7	I	Serial data input. Input from a connected communications device
SOUT	11	13	8	O	Composite serial data output. Output to a connected communication device. SOUT is set to the marking (set) state as a result of master reset.
$\overline{TXRDY}$	24	27	23	O	Transmitter ready output. Transmitter DMA signalling is available with this terminal. When operating in the FIFO mode, one of two types of DMA signalling can be selected using FCR3. When operating in the TL16C450 mode, only DMA mode 0 is allowed. Mode 0 supports single-transfer DMA in which a transfer is made between CPU bus cycles. Mode 1 supports multitransfer DMA in which multiple transfers are made continuously until the transmit FIFO has been filled.
V <sub>CC</sub>	40	44	42		5-V supply voltage
V <sub>SS</sub>	20	22	18		Supply common
$\overline{WR1}$ WR2	18 19	20 21	16 17	I	Write inputs. When either input is active (high or low respectively) and while the ACE is selected, the CPU is allowed to write control words or data into a selected ACE register. Only one of these inputs is required to transfer data during a write operation; the other input should be tied in its inactive state (i.e., WR2 tied low or $\overline{WR1}$ tied high).
XIN XOUT	16 17	18 19	14 15	I/O	External clock. XIN and XOUT connect the ACE to the main timing reference (clock or crystal).



# TL16C550B, TL16C550BI ASYNCHRONOUS COMMUNICATIONS ELEMENT

SLLS136B – JANUARY 1994 – REVISED AUGUST 1996

## absolute maximum ratings over operating free-air temperature range (unless otherwise noted)†

Supply voltage range, $V_{CC}$ (see Note 1)	–0.5 V to 7 V
Input voltage range at any input, $V_I$	–0.5 V to 7 V
Output voltage range, $V_O$	–0.5 V to 7 V
Continuous total power dissipation at (or below) 70°C	300 mW
Storage temperature range, $T_{stg}$	–65°C to 150°C
Operating free-air temperature range, $T_A$ : TL16C550B	0°C to 70°C
TL16C550BI	–40°C to 85°C
Case temperature for 10 seconds, $T_C$ : FN package	260°C
Lead temperature 1,6 mm (1/16 inch) from case for 10 seconds: N or PT package	260°C

† Stresses beyond those listed under “absolute maximum ratings” may cause permanent damage to the device. These are stress ratings only and functional operation of the device at these or any other conditions beyond those indicated under “recommended operating conditions” is not implied. Exposure to absolute-maximum-rated conditions for extended periods may affect device reliability.

NOTE 1: All voltage values are with respect to  $V_{SS}$  (ground).

## recommended operating conditions

	MIN	NOM	MAX	UNIT	
Supply voltage, $V_{CC}$	4.75	5	5.25	V	
High-level input voltage, $V_{IH}$	2	$V_{CC}$		V	
Low-level input voltage, $V_{IL}$	–0.5		0.8	V	
Operating free-air temperature, $T_A$	TL16C550B		0	70	°C
	TL16C550BI		–40	85	°C

## electrical characteristics over recommended ranges of supply voltage and operating free-air temperature (unless otherwise noted)

PARAMETER	TEST CONDITIONS	MIN	TYP†	MAX	UNIT
$V_{OH}‡$ High-level output voltage	$I_{OH} = -1$ mA	2.4			V
$V_{OL}‡$ Low-level output voltage	$I_{OL} = 1.6$ mA			0.4	V
$I_I$ Input current	$V_{CC} = 5.25$ V, $V_I = 0$ to 5.25 V, $V_{SS} = 0$ , All other terminals floating			10	μA
$I_{OZ}$ High-impedance-state output current	$V_{CC} = 5.25$ V, $V_O = 0$ to 5.25 V, Chip selected in write mode or chip deselect			±20	μA
$I_{CC}$ Supply current	$V_{CC} = 5.25$ V, $T_A = 25^\circ\text{C}$ , SIN, DSR, DCD, CTS, and RI at 2 V, All other inputs at 0.8 V, XTAL1 at 4 MHz, No load on outputs, Baud rate = 50 kbit/s			10	mA
$C_{i(\text{CLK})}$ Clock input capacitance			15	20	pF
$C_{o(\text{CLK})}$ Clock output capacitance			20	30	pF
$C_i$ Input capacitance	$V_{CC} = 0$ , $V_{SS} = 0$ , $f = 1$ MHz, $T_A = 25^\circ\text{C}$ , All other terminals grounded		6	10	pF
$C_o$ Output capacitance			10	20	pF

† All typical values are at  $V_{CC} = 5$  V,  $T_A = 25^\circ\text{C}$ .

‡ These parameters apply for all outputs except XOUT.



# TL16C550B, TL16C550BI

## ASYNCHRONOUS COMMUNICATIONS ELEMENT

SLLS136B – JANUARY 1994 – REVISED AUGUST 1996

### system timing requirements over recommended ranges of supply voltage and operating free-air temperature

PARAMETER	ALT. SYMBOL	FIGURE	TEST CONDITIONS	MIN	MAX	UNIT
t <sub>cR</sub> Cycle time, read (t <sub>w7</sub> + t <sub>d8</sub> + t <sub>d9</sub> )	RC			87		ns
t <sub>cW</sub> Cycle time, write (t <sub>w6</sub> + t <sub>d5</sub> + t <sub>d6</sub> )	WC			87		ns
t <sub>w1</sub> Pulse duration, clock high	t <sub>XH</sub>	1	f = 9 MHz maximum	40		ns
t <sub>w2</sub> Pulse duration, clock low	t <sub>XL</sub>	1	f = 9 MHz maximum	40		ns
t <sub>w5</sub> Pulse duration, address strobe low	t <sub>ADS</sub>	2,3		9		ns
t <sub>w6</sub> Pulse duration, write strobe	t <sub>WR</sub>	2		40		ns
t <sub>w7</sub> Pulse duration, read strobe	t <sub>RD</sub>	3		40		ns
t <sub>w8</sub> Pulse duration, master reset	t <sub>MR</sub>			1		μs
t <sub>su1</sub> Setup time, address valid before $\overline{\text{ADS}}\uparrow$	t <sub>AS</sub>	2,3		8		ns
t <sub>su2</sub> Setup time, chip select valid before $\overline{\text{ADS}}\uparrow$	t <sub>CS</sub>	2,3		8		ns
t <sub>su3</sub> Setup time, data valid before $\overline{\text{WR}}1\downarrow$ or $\text{WR}2\uparrow$	t <sub>DS</sub>	2		15		ns
t <sub>h1</sub> Hold time, address low after $\overline{\text{ADS}}\uparrow$	t <sub>AH</sub>	2,3		0		ns
t <sub>h2</sub> Hold time, chip select valid after $\overline{\text{ADS}}\uparrow$	t <sub>CH</sub>	2,3		0		ns
t <sub>h3</sub> Hold time, chip select valid after $\overline{\text{WR}}1\uparrow$ or $\text{WR}2\downarrow$	t <sub>WCS</sub>	2		10		ns
t <sub>h4</sub> Hold time, address valid after $\overline{\text{WR}}1\uparrow$ or $\text{WR}2\downarrow$	t <sub>WA</sub>	2		10		ns
t <sub>h5</sub> Hold time, data valid after $\overline{\text{WR}}1\uparrow$ or $\text{WR}2\downarrow$	t <sub>DH</sub>	2		5		ns
t <sub>h6</sub> Hold time, chip select valid after $\overline{\text{RD}}1\uparrow$ or $\text{RD}2\downarrow$	t <sub>RCS</sub>	3		10		ns
t <sub>h7</sub> Hold time, address valid after $\overline{\text{RD}}1\uparrow$ or $\text{RD}2\downarrow$	t <sub>RA</sub>	3		20		ns
t <sub>d4</sub> <sup>†</sup> Delay time, chip select valid before $\overline{\text{WR}}1\downarrow$ or $\text{WR}2\uparrow$	t <sub>CSW</sub>	2		7		ns
t <sub>d5</sub> <sup>†</sup> Delay time, address valid before $\overline{\text{WR}}1\downarrow$ or $\text{WR}2\uparrow$	t <sub>AW</sub>	2		7		ns
t <sub>d6</sub> <sup>†</sup> Delay time, write cycle, $\overline{\text{WR}}1\uparrow$ or $\text{WR}2\downarrow$ to $\overline{\text{ADS}}\downarrow$	t <sub>WC</sub>	2		40		ns
t <sub>d7</sub> <sup>†</sup> Delay time, chip select valid to $\overline{\text{RD}}1\downarrow$ or $\text{RD}2\uparrow$	t <sub>CSR</sub>	3		7		ns
t <sub>d8</sub> <sup>†</sup> Delay time, address valid to $\overline{\text{RD}}1\downarrow$ or $\text{RD}2\uparrow$	t <sub>AR</sub>	3		7		ns
t <sub>d9</sub> Delay time, read cycle, $\overline{\text{RD}}1\uparrow$ or $\text{RD}2\downarrow$ to $\overline{\text{ADS}}\downarrow$	t <sub>RC</sub>	3		40		ns
t <sub>d10</sub> Delay time, $\overline{\text{RD}}1\downarrow$ or $\text{RD}2\uparrow$ to data valid	t <sub>RVD</sub>	3	C <sub>L</sub> = 75 pF	45		ns
t <sub>d11</sub> Delay time, $\overline{\text{RD}}1\uparrow$ or $\text{RD}2\downarrow$ to floating data	t <sub>HZ</sub>	3	C <sub>L</sub> = 75 pF	20		ns

<sup>†</sup> Only applies when  $\overline{\text{ADS}}$  is low

### system switching characteristics over recommended ranges of supply voltage and operating free-air temperature (see Note 2)

PARAMETER	ALT. SYMBOL	FIGURE	TEST CONDITIONS	MIN	MAX	UNIT
t <sub>dis(R)</sub> Disable time, $\overline{\text{RD}}1\uparrow\downarrow$ or $\text{RD}2\downarrow\uparrow$ to $\text{DDIS}\uparrow\downarrow$	t <sub>RDD</sub>	3	C <sub>L</sub> = 75 pF	20		ns

NOTE 2: Charge and discharge time is determined by V<sub>OL</sub>, V<sub>OH</sub>, and external loading.

### baud generator switching characteristics over recommended ranges of supply voltage and operating free-air temperature, C<sub>L</sub> = 75 pF

PARAMETER	ALT. SYMBOL	FIGURE	TEST CONDITIONS	MIN	MAX	UNIT
t <sub>w3</sub> Pulse duration, $\overline{\text{BAUDOUT}}$ low	t <sub>LW</sub>	1	f = 9 MHz, CLK ÷ 2	80		ns
t <sub>w4</sub> Pulse duration, $\overline{\text{BAUDOUT}}$ high	t <sub>HW</sub>	1	f = 9 MHz, CLK ÷ 2	80		ns
t <sub>d1</sub> Delay time, XIN $\uparrow$ to $\overline{\text{BAUDOUT}}\uparrow$	t <sub>BLD</sub>	1			75	ns
t <sub>d2</sub> Delay time, XIN $\uparrow\downarrow$ to $\overline{\text{BAUDOUT}}\downarrow$	t <sub>BHD</sub>	1			65	ns



# TL16C550B, TL16C550BI ASYNCHRONOUS COMMUNICATIONS ELEMENT

SLLS136B – JANUARY 1994 – REVISED AUGUST 1996

## receiver switching characteristics over recommended ranges of supply voltage and operating free-air temperature (see Note 3)

PARAMETER	ALT. SYMBOL	FIGURE	TEST CONDITIONS	MIN	MAX	UNIT
t <sub>d12</sub> Delay time, RCLK to sample	t <sub>SCD</sub>	4			10	ns
t <sub>d13</sub> Delay time, stop to set interrupt or read RBR to LSI interrupt or stop to RXRDY↓	t <sub>SINT</sub>	4,5,6,7,8			1	RCLK cycle
t <sub>d14</sub> Delay time, read RBR/LSR to reset interrupt low	t <sub>RINT</sub>	4,5,6,7,8	C <sub>L</sub> = 75 pF		40	ns

NOTE 3: In the FIFO mode, the read cycle (RC) = 425 ns (minimum) between reads of the receiver FIFO and the status registers (interrupt identification register or line status register).

## transmitter switching characteristics over recommended ranges of supply voltage and operating free-air temperature

PARAMETER	ALT. SYMBOL	FIGURE	TEST CONDITIONS	MIN	MAX	UNIT
t <sub>d15</sub> Delay time, initial write (INTRPT low) to transmit start (SOUT low)	t <sub>IRS</sub>	9		8	24	baudout cycles
t <sub>d16</sub> Delay time, stop (SOUT low) to interrupt (INTRPT high)	t <sub>STI</sub>	9		8	9	baudout cycles
t <sub>d17</sub> Delay time, WR THR high to reset interrupt (INTRPT low)	t <sub>HR</sub>	9	C <sub>L</sub> = 75 pF		50	ns
t <sub>d18</sub> Delay time, initial WR THR low to THRE interrupt (INTRPT high)	t <sub>SI</sub>	9		16	32	baudout cycles
t <sub>d19</sub> Delay time, RD IIR low to reset THRE interrupt (INTRPT low)	t <sub>IR</sub>	9	C <sub>L</sub> = 75 pF		35	ns
t <sub>d20</sub> Delay time, WR THR high to TXRDY high (inactive)	t <sub>WXI</sub>	10,11	C <sub>L</sub> = 75 pF		35	ns
t <sub>d21</sub> Delay time, start (SOUT low) to TXRDY low (active)	t <sub>SXA</sub>	10,11	C <sub>L</sub> = 75 pF		8	baudout cycles

## modem control switching characteristics over recommended ranges of supply voltage and operating free-air temperature, C<sub>L</sub> = 75 pF

PARAMETER	ALT. SYMBOL	FIGURE	MIN	MAX	UNIT
t <sub>d22</sub> Delay time, WR MCR low to output (RTS, DTR, OUT1, OUT2) low or high	t <sub>MDO</sub>	12		50	ns
t <sub>d23</sub> Delay time, modem interrupt (CTS, DSR, DCD) low to set interrupt (INTRPT) high	t <sub>SIM</sub>	12		35	ns
t <sub>d24</sub> Delay time, RD MSR low to reset interrupt (INTRPT) low	t <sub>RIM</sub>	12		40	ns

# TL16C550B, TL16C550BI ASYNCHRONOUS COMMUNICATIONS ELEMENT

SLLS136B – JANUARY 1994 – REVISED AUGUST 1996

## PARAMETER MEASUREMENT INFORMATION

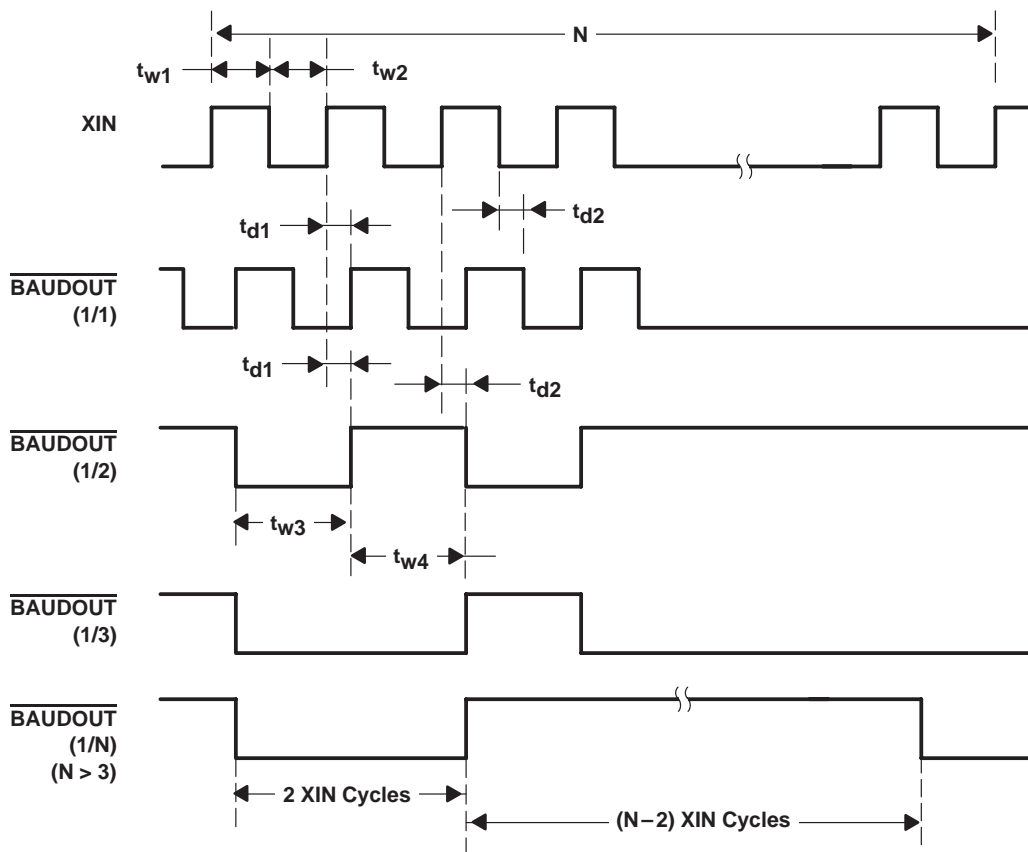
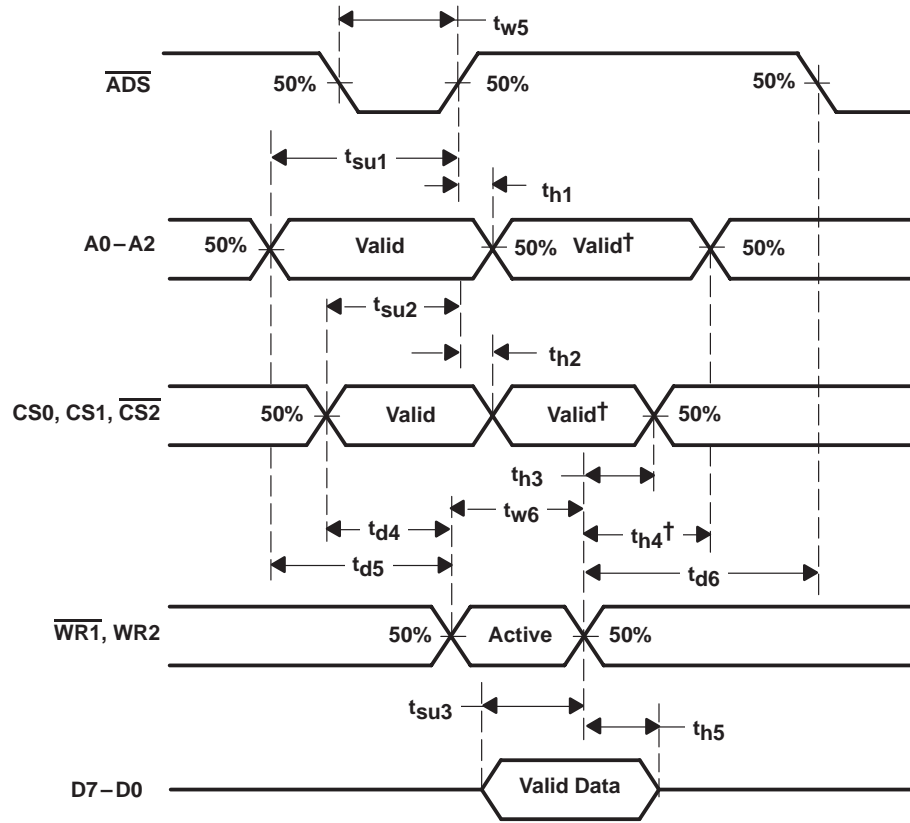

Figure 1. Baud Generator Timing Waveforms

PARAMETER MEASUREMENT INFORMATION



† Applicable only when  $\overline{ADS}$  is low.

Figure 2. Write Cycle Timing Waveforms

# TL16C550B, TL16C550BI ASYNCHRONOUS COMMUNICATIONS ELEMENT

SLLS136B – JANUARY 1994 – REVISED AUGUST 1996

## PARAMETER MEASUREMENT INFORMATION

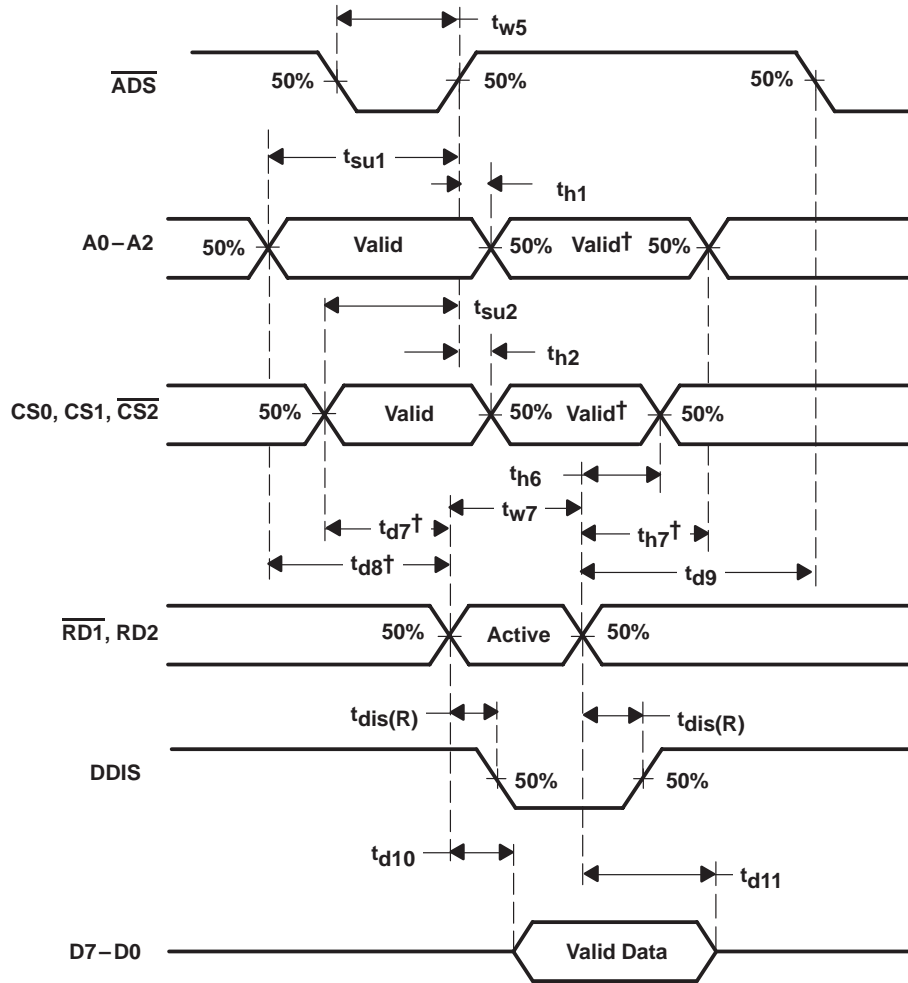

† Applicable only when  $\overline{ADS}$  is low.

Figure 3. Read Cycle Timing Waveforms

PARAMETER MEASUREMENT INFORMATION

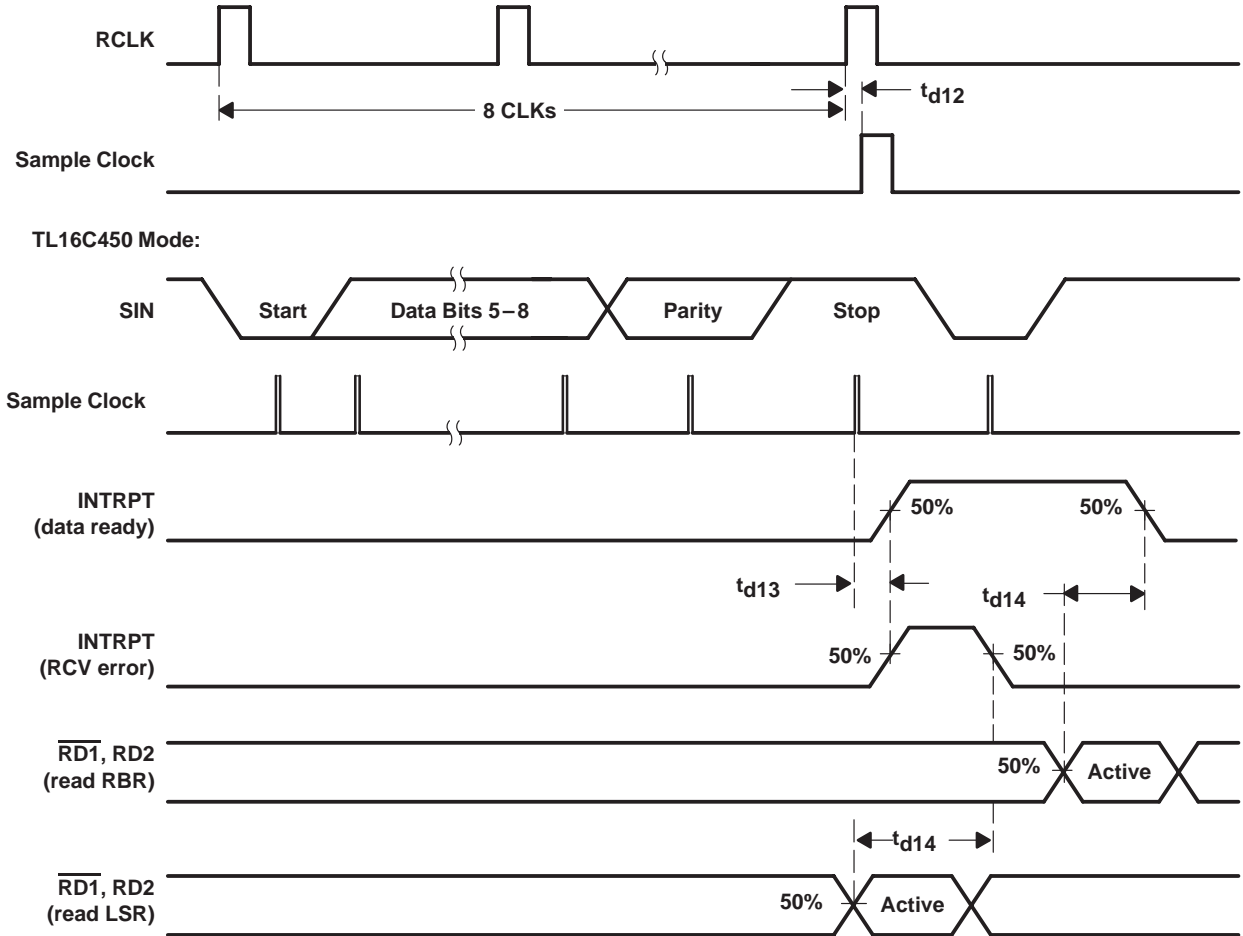
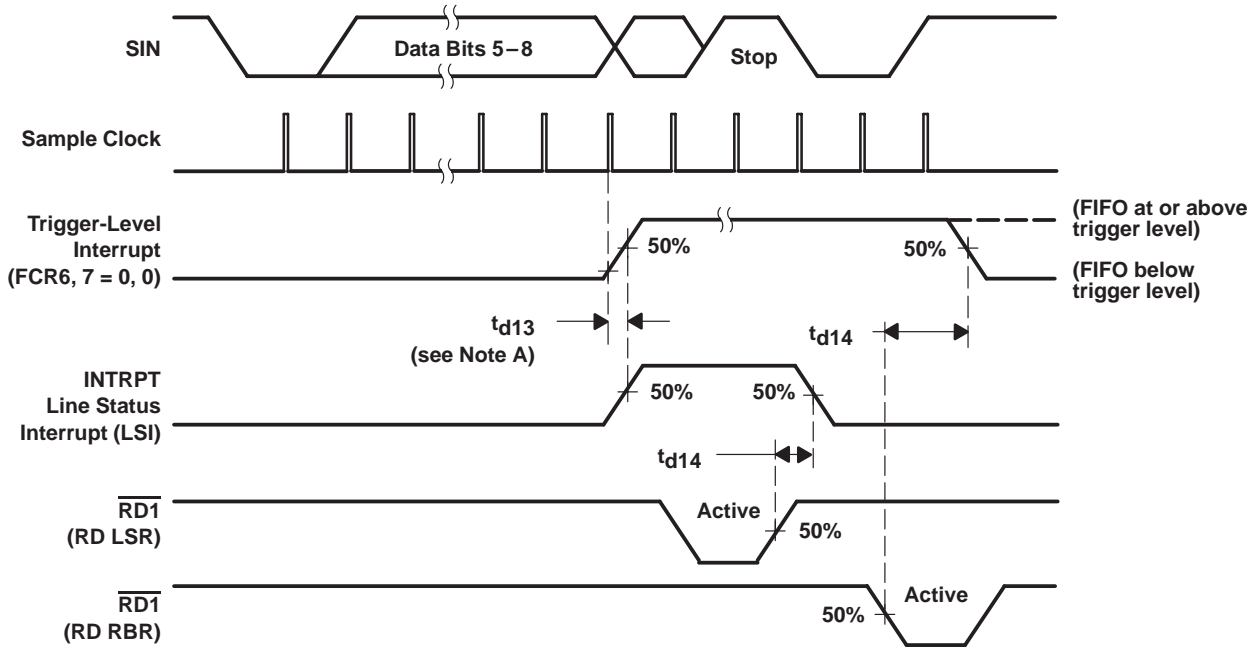

Figure 4. Receiver Timing Waveforms

# TL16C550B, TL16C550BI ASYNCHRONOUS COMMUNICATIONS ELEMENT

SLLS136B – JANUARY 1994 – REVISED AUGUST 1996

## PARAMETER MEASUREMENT INFORMATION



NOTE A: For a timeout interrupt,  $t_{d13} = 8$  RCLKs.

Figure 5. Receiver FIFO First Byte (Sets DR Bit) Waveforms

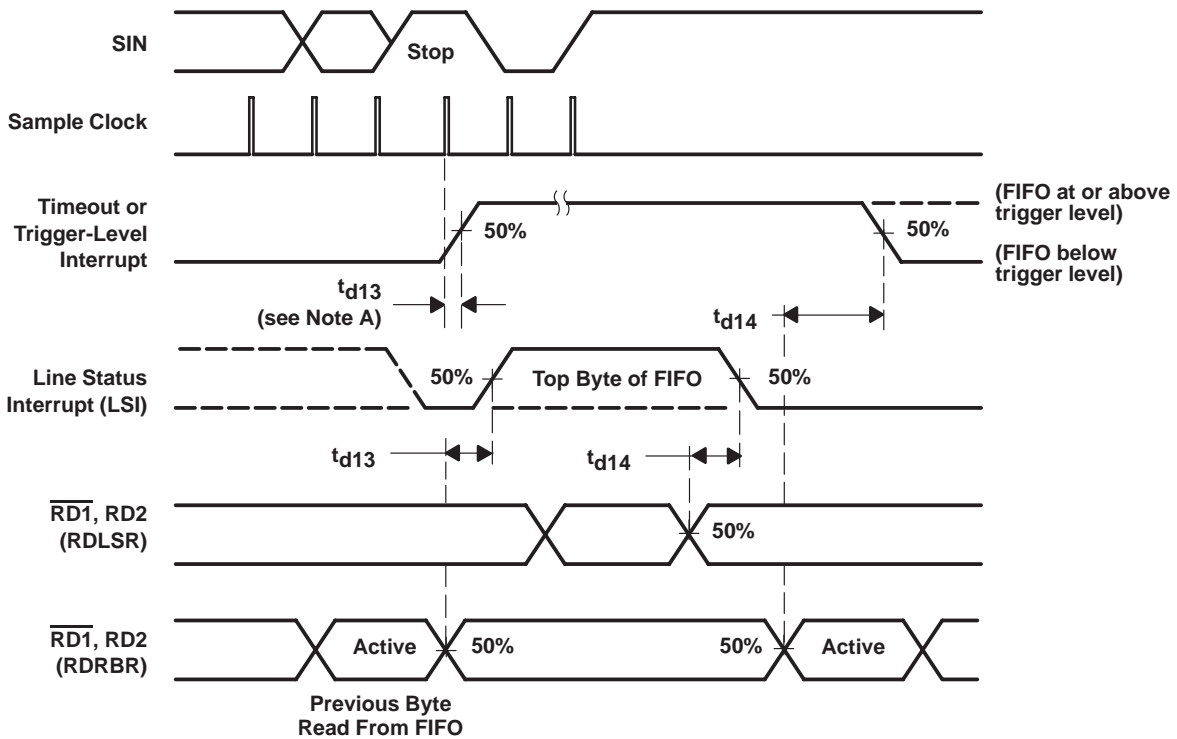

NOTE A: For a timeout interrupt,  $t_{d13} = 8$  RCLKs.

Figure 6. Receiver FIFO Bytes Other Than the First Byte (DR Internal Bit Already Set) Waveforms



POST OFFICE BOX 655303 • DALLAS, TEXAS 75265

PARAMETER MEASUREMENT INFORMATION

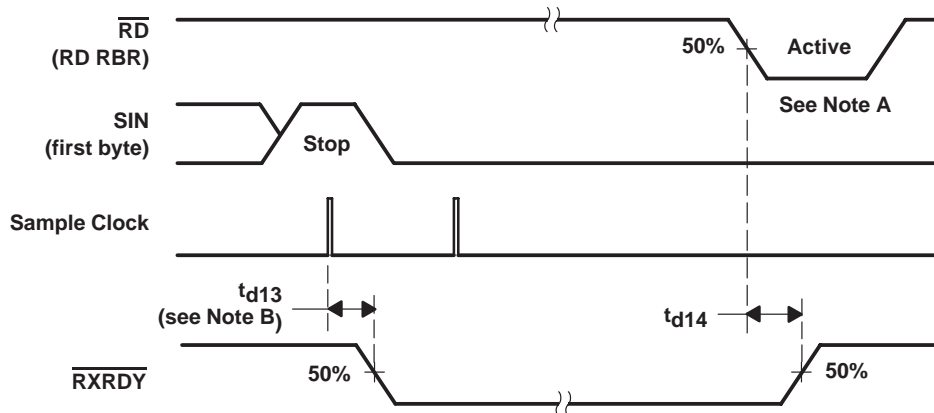

NOTES: A. This is the reading of the last byte in the FIFO.  
 B. For a timeout interrupt,  $t_{d13} = 8$  RCLKs.

Figure 7. Receiver Ready ( $\overline{RXRDY}$ ) Waveforms, FCR0 = 0 or FCR0 = 1 and FCR3 = 0 (Mode 0)

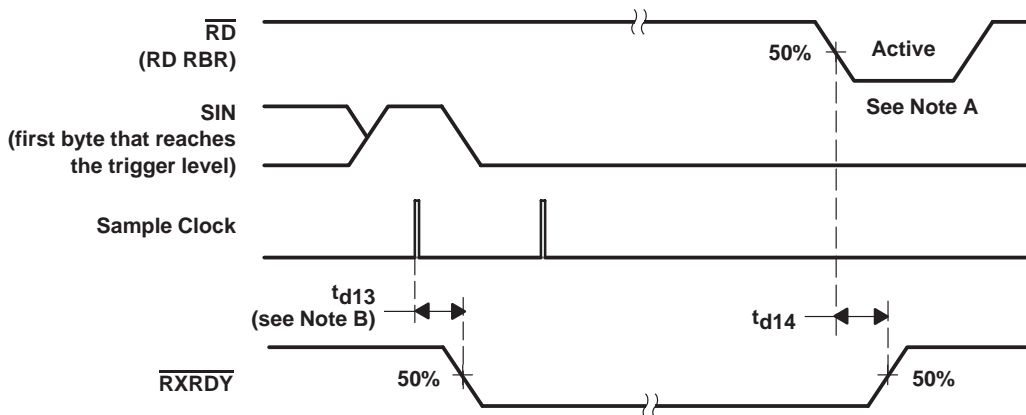

NOTES: A. This is the reading of the last byte in the FIFO.  
 B. For a timeout interrupt,  $t_{d13} = 8$  RCLKs.

Figure 8. Receiver Ready ( $\overline{RXRDY}$ ) Waveforms, FCR = 1 or FCR3 = 1 (Mode 1)

PARAMETER MEASUREMENT INFORMATION

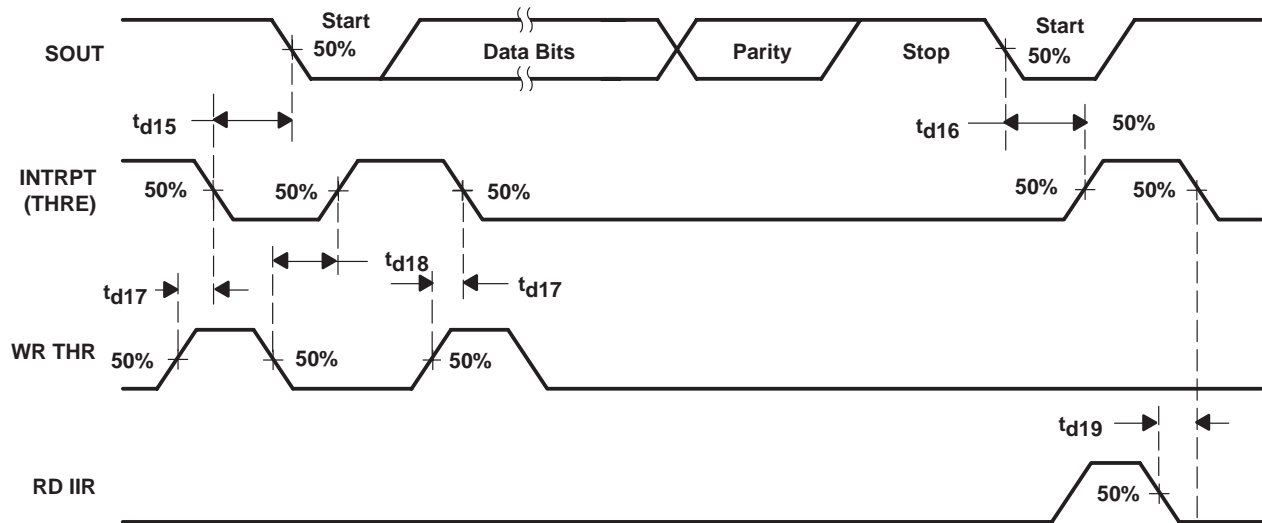

Figure 9. Transmitter Timing Waveforms

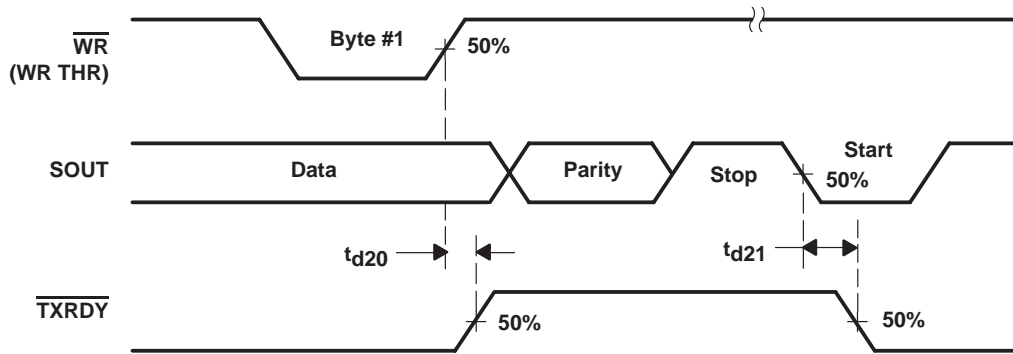

Figure 10. Transmitter Ready ( $\overline{TXRDY}$ ) Waveforms, FCR0 = 0 or FCR0 = 1 and FCR3 = 0 (Mode 0)

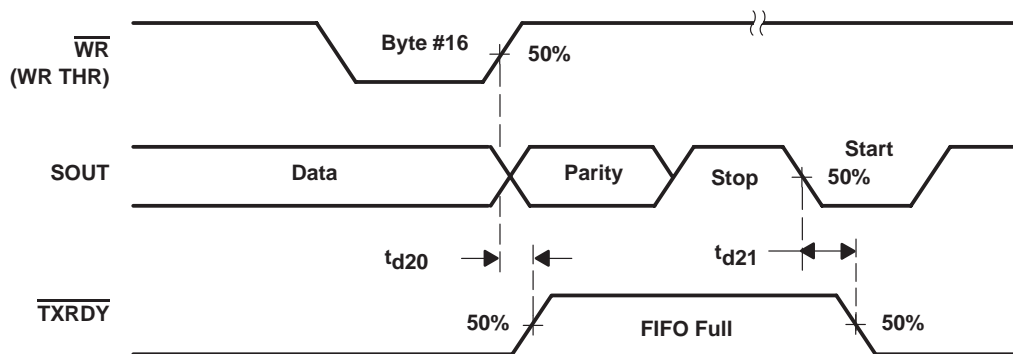

Figure 11. Transmitter Ready ( $\overline{TXRDY}$ ) Waveforms, FCR0 = 1 and FCR3 = 1 (Mode 1)

PARAMETER MEASUREMENT INFORMATION

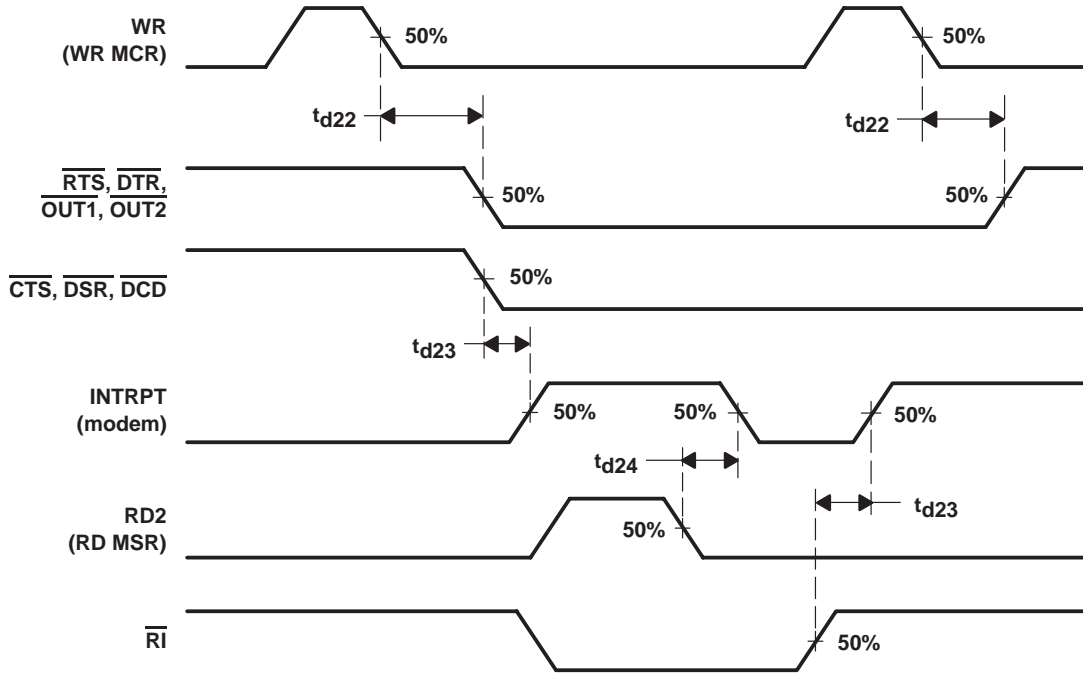

Figure 12. Modem Control Timing Waveforms

# TL16C550B, TL16C550BI ASYNCHRONOUS COMMUNICATIONS ELEMENT

SLLS136B – JANUARY 1994 – REVISED AUGUST 1996

## APPLICATION INFORMATION

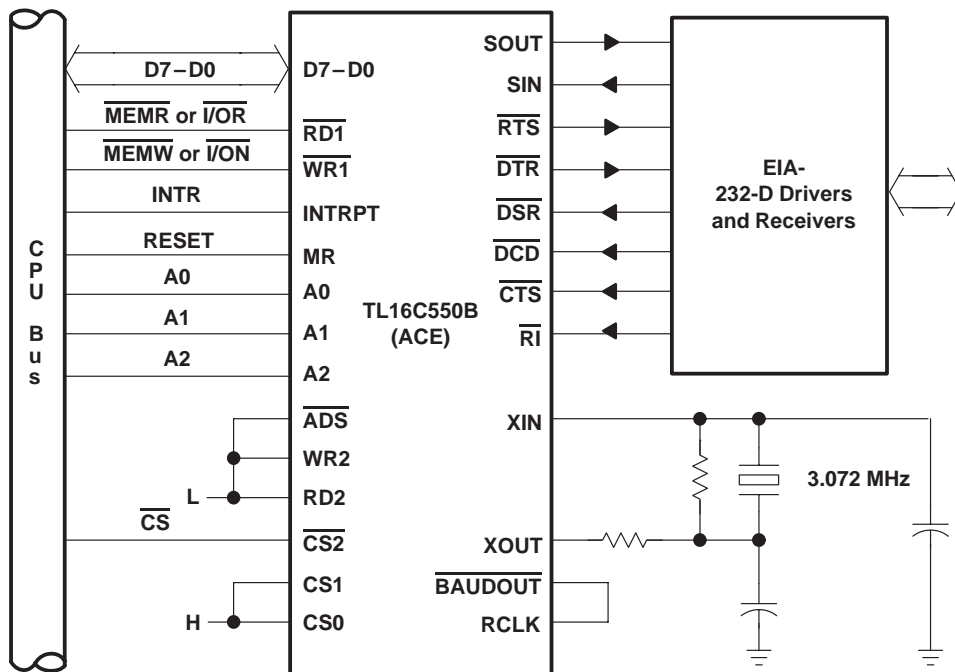

Figure 13. Basic TL16C550B Configuration

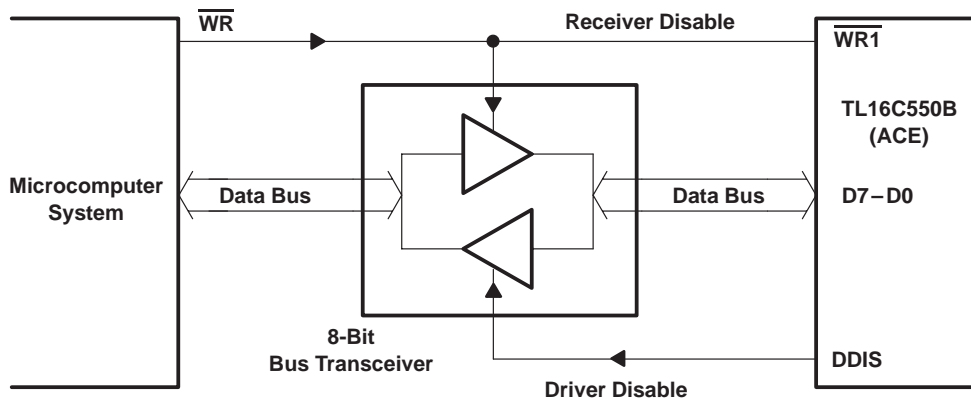
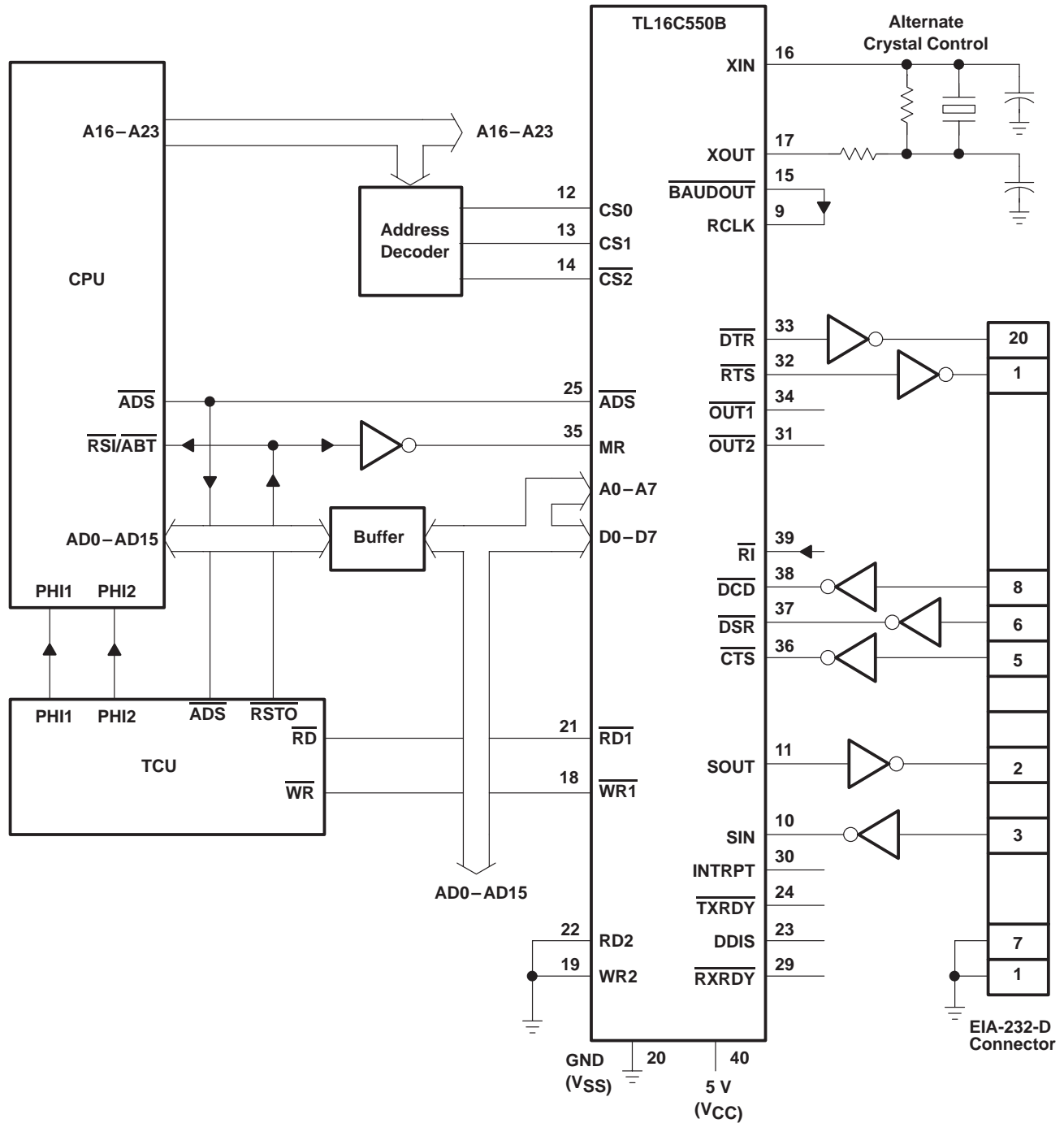

Figure 14. Typical Interface for a High-Capacity Data Bus

APPLICATION INFORMATION



Terminal numbers shown are for the N package.

Figure 15. Typical TL16C550B Connection to a CPU

# TL16C550B, TL16C550BI ASYNCHRONOUS COMMUNICATIONS ELEMENT

SLLS136B – JANUARY 1994 – REVISED AUGUST 1996

## PRINCIPLES OF OPERATION

**Table 1. Register Selection**

DLAB†	A2	A1	A0	REGISTER
0	L	L	L	Receiver buffer (read), transmitter holding (write)
0	L	L	H	Interrupt enable register
X	L	H	L	Interrupt identification register (read only)
X	L	H	L	FIFO control register (write)
X	L	H	H	Line control register
X	H	L	L	Modem control register
X	H	L	H	Line status register
X	H	H	L	Modem status register
X	H	H	H	Scratch register
1	L	L	L	Divisor latch (LSB)
1	L	L	H	Divisor latch (MSB)

† The divisor latch access bit (DLAB) is the most significant bit of the line control register. The DLAB signal is controlled by writing to this bit location (see Table 3).

**Table 2. ACE Reset Functions**

REGISTER/SIGNAL	RESET CONTROL	RESET STATE
Interrupt Enable Register	Master Reset	All bits cleared (bits 0–3 forced and bits 4–7 permanent)
Interrupt Identification Register	Master Reset	Bit 0 is set, bits 1–3 are cleared, and bits 4–7 are permanently cleared
FIFO Control Register	Master Reset	All bits cleared
Line Control Register	Master Reset	All bits cleared
Modem Control Register	Master Reset	All bits cleared (5–7 permanent)
Line Status Register	Master Reset	Bits 5 and 6 are set, all other bits are cleared
Modem Status Register	Master Reset	Bits 0–3 are cleared, bits 4–7 are input signals
SOUT	Master Reset	High
INTRPT (receiver error flag)	Read LSR/MR	Low
INTRPT (received data available)	Read RBR/MR	Low
INTRPT (transmitter holding register empty)	Read IR/Write THR/MR	Low
INTRPT (modem status changes)	Read MSR/MR	Low
OUT2	Master Reset	High
RTS	Master Reset	High
DTR	Master Reset	High
OUT1	Master Reset	High
Scratch Register	Master Reset	No effect
Divisor Latch (LSB and MSB) Registers	Master Reset	No effect
Receiver Buffer Registers	Master Reset	No effect
Transmitter Holding Registers	Master Reset	No effect
RCVR FIFO	MR/FCR1–FCR0/ ΔFCR0	All bits low
XMIT FIFO	MR/FCR2–FCR0/ ΔFCR0	All bits low

## PRINCIPLES OF OPERATION

### accessible registers

The system programmer, using the CPU, has access to and control over any of the ACE registers that are summarized in Table 3. These registers control ACE operations, receive data, and transmit data. Descriptions of these registers follow Table 3.

**Table 3. Summary of Accessible Registers**

Bit No.	REGISTER ADDRESS											
	0DLAB=0	0DLAB=0	1DLAB=0	2	2	3	4	5	6	7	0DLAB=1	1DLAB=1
	Receiver Buffer Register (Read Only)	Transmitter Holding Register (Write Only)	Interrupt Enable Register	Interrupt Ident. Register (Read Only)	FIFO Control Register (Write Only)	Line Control Register	Modem Control Register	Line Status Register	Modem Status Register	Scratch Register	Divisor Latch (LSB)	Latch (MSB)
	RBR	THR	IER	IIR	FCR	LCR	MCR	LSR	MSR	SCR	DLL	DLM
0	Data Bit 0†	Data Bit 0	Enable Received Data Available Interrupt (ERBI)	0 if interrupt Pending	FIFO Enable	Word Length Select Bit 0 (WLS0)	Data Terminal Ready (DTR)	Data Ready (DR)	Delta Clear to Send (ΔCTS)	Bit 0	Bit 0	Bit 8
1	Data Bit 1	Data Bit 1	Enable Transmitter Holding Register Empty Interrupt (ETBEI)	Interrupt ID Bit (1)	Receiver FIFO Reset	Word Length Select Bit 1 (WLS1)	Request to Send (RTS)	Overrun Error (OE)	Delta Data Set Ready (ΔDSR)	Bit 1	Bit 1	Bit 9
2	Data Bit 2	Data Bit 2	Enable Receiver Line Status Interrupt (ELSI)	Interrupt ID Bit (2)	Transmitter FIFO Reset	Number of Stop Bits (STB)	OUT1	Parity Error (PE)	Trailing Edge Ring Indicator (TERI)	Bit 2	Bit 2	Bit 10
3	Data Bit 3	Data Bit 3	Enable Modem Status Interrupt (EDSSI)	Interrupt ID Bit (2) (see Note 4)	DMA Mode Select	Parity Enable (PEN)	OUT2	Framing Error (FE)	Delta Data Carrier Detect (ΔDCD)	Bit 3	Bit 3	Bit 11
4	Data Bit 4	Data Bit 4	0	0	Reserved	Even Parity Select (EPS)	Loop	Break Interrupt (BI)	Clear to Send (CTS)	Bit 4	Bit 4	Bit 12
5	Data Bit 5	Data Bit 5	0	0	Reserved	Stick Parity	0	Transmitter Holding Register (THRE)	Data Set Ready (DSR)	Bit 5	Bit 5	Bit 13
6	Data Bit 6	Data Bit 6	0	FIFOs Enabled (see Note 4)	Receiver Trigger (LSB)	Break Control	0	Transmitter Empty (TEMT)	Ring Indicator (RI)	Bit 6	Bit 6	Bit 14
7	Data Bit 7	Data Bit 7	0	FIFOs Enabled (see Note 4)	Receiver Trigger (MSB)	Divisor Latch Access Bit (DLAB)	0	Error in RCVR FIFO (see Note 4)	Data Carrier Detect (DCD)	Bit 7	Bit 7	Bit 15

† Bit 0 is the least significant bit. It is the first bit serially transmitted or received.

NOTE 4: These bits are always 0 in the TL16C450 mode.

**PRINCIPLES OF OPERATION**

**FIFO control register (FCR)**

The FCR is a write-only register at the same location as the IIR, which is a read-only register. The FCR enables the FIFOs, clears the FIFOs, sets the receiver FIFO trigger level, and selects the type of DMA signalling.

Bit 0: FCR0, when set, enables the transmit and receive FIFOs. This bit must be set when other FCR bits are written to or they are not programmed. Changing this bit clears the FIFOs.

- Bit 1: FCR1, when set, clears all bytes in the receiver FIFO and clears its counter. The shift register is not cleared. The one that is written to this bit position is self clearing.
- Bit 2: FCR2, when set, clears all bytes in the transmit FIFO and clears its counter. The shift register is not cleared. The one that is written to this bit position is self clearing.
- Bit 3: When FCR0 is set, setting FCR3 causes the  $\overline{\text{RXRDY}}$  and  $\overline{\text{TXRDY}}$  to change from mode 0 to mode 1.
- Bits 4 and 5: FCR4 and FCR5 are reserved for future use.
- Bits 6 and 7: FCR6 and FCR7 set the trigger level for the receiver FIFO interrupt (see Table 4).

**Table 4. Receiver FIFO Trigger Level**

BIT 7	BIT 6	RECEIVER FIFO TRIGGER LEVEL (BYTES)
0	0	01
0	1	04
1	0	08
1	1	14

**FIFO interrupt mode operation**

When the receiver FIFO and receiver interrupts are enabled (FCR0 = 1, IER0 = 1) receiver interrupt occur as follows:

1. The receive data available interrupt is issued to the microprocessor when the FIFO has reached its programmed trigger level. It is cleared when the FIFO drops below its programmed trigger level.
2. The IIR receive data available indication also occurs when the FIFO trigger level is reached, and like the interrupt, it is cleared when the FIFO drops below the trigger level.
3. The receiver line status interrupt (IIR = 0110) has higher priority than the received data available interrupt (IIR = 0100).
4. The data ready bit (LSR0) is set when a character is transferred from the shift register to the receiver FIFO. It is cleared when the FIFO is empty.



## PRINCIPLES OF OPERATION

### FIFO interrupt mode operation (continued)

When the receiver FIFO and receiver interrupts are enabled, receiver FIFO timeout interrupt occurs as follows:

1. FIFO timeout interrupt occurs when the following conditions exist:
  - a. At least one character is in the FIFO.
  - b. The most recent serial character received is longer than four continuous character times ago (when two stop bits are programmed, the second one is included in this time delay).
  - c. The most recent microprocessor read of the FIFO is longer than four continuous character times ago. This causes a maximum character received to interrupt an issued delay of 160 ms at 300 baud with a 12-bit character.
2. Character times are calculated by using the RCLK input for a clock signal (makes the delay proportional to the baud rate).
3. When a timeout interrupt has occurred, it is cleared and the timer is reset when the microprocessor reads one character from the receiver FIFO.
4. When a timeout interrupt has not occurred, the timeout timer is reset after a new character is received or after the microprocessor reads the receiver FIFO.

When the transmit FIFO and transmitter interrupts are enabled (FCR0 = 1, IER1 = 1), transmit interrupts occur as follows:

1. The transmitter holding register interrupt (02) occurs when the transmit FIFO is empty. It is cleared as soon as the THR is written to (1 to 16 characters may be written to the transmit FIFO while servicing this interrupt) or the IIR is read.
2. The transmit FIFO empty indications are delayed one character time minus the last stop bit time when the following occurs: THRE = 1 and there have not been at least two bytes at the same time in the transmit FIFO since the last THRE = 1. The first transmitter interrupt after changing FCR0 is immediate when it is enabled.

Character timeout and receiver FIFO trigger level interrupts have the same priority as the current received data available interrupt; transmit FIFO empty has the same priority as the current THRE interrupt.

### FIFO polled mode operation

When FCR0 is set, clearing IER0, IER1, IER2, IER3, or all four puts the ACE in the FIFO polled mode of operation. Since the receiver and transmitter are controlled separately, either one or both can be in the polled mode of operation.

In this mode, the user program checks receiver and transmitter status via the LSR. As stated previously:

- LSR0 is set as long as there is one byte in the receiver FIFO.
- LSR1 – LSR4 specify which error(s) have occurred. Character error status is handled the same way as when in the interrupt mode; the IIR is not affected since IER2 = 0.
- LSR5 indicates when the transmit FIFO is empty.
- LSR6 indicates that both the transmit FIFO and shift registers are empty.
- LSR7 indicates whether there are any errors in the receiver FIFO.

There is no trigger level reached or timeout condition indicated in the FIFO polled mode. However, the receiver and transmit FIFOs are still fully capable of holding characters.

# TL16C550B, TL16C550BI

## ASYNCHRONOUS COMMUNICATIONS ELEMENT

SLLS136B – JANUARY 1994 – REVISED AUGUST 1996

---

### PRINCIPLES OF OPERATION

#### interrupt enable register (IER)

The IER enables each of the five types of interrupts (refer to Table 5) and the INTRPT output signal in response to an interrupt generation. The IER can also disable the interrupt system by clearing bits 0 through 3. The contents of this register are summarized in Table 3 and are described in the following bulleted list.

- Bit 0: This bit when set enables the received data available interrupt.
- Bit 1: This bit when set enables the THRE interrupt.
- Bit 2: This bit when set enables the receiver line status interrupt.
- Bit 3: This bit when set enables the modem status interrupt.
- Bits 4 – 7: These bits in the IER are not used and are always cleared.

#### interrupt identification register (IIR)

The ACE has an on-chip interrupt generation and prioritization capability that permits a flexible interface with most popular microprocessors. The ACE provides four prioritized levels of interrupts which are:

- Priority 1 – Receiver line status (highest priority)
- Priority 2 – Receiver data ready or receiver character timeout
- Priority 3 – Transmitter holding register empty
- Priority 4 – Modem status (lowest priority)

When an interrupt is generated, the IIR indicates that an interrupt is pending and the type of that interrupt in its three least significant bits (bits 0, 1, and 2). The contents of this register are summarized in Table 3 and described in Table 4. Detail on each bit are as follows:

- Bit 0: This bit can be used either in a hardwire prioritized or polled interrupt system. When this bit is cleared, an interrupt is pending. When bit 0 is set, no interrupt is pending.
- Bits 1 and 2: These two bits identify the highest priority interrupt pending, as indicated in Table 5.
- Bit 3: This bit is always cleared in the TL16C450 mode. In FIFO mode, this bit is set with bit 2 to indicate that a timeout interrupt is pending.
- Bits 4 – 5: These two bits are not used and are always cleared.
- Bits 6 and 7: These two bits are always cleared in the TL16C450 mode. They are set when bit 0 of the FIFO control register is set.



**PRINCIPLES OF OPERATION**

**interrupt identification register (IIR) (continued)**

**Table 5. Interrupt Control Functions**

INTERRUPT IDENTIFICATION REGISTER				PRIORITY LEVEL	INTERRUPT TYPE	INTERRUPT SOURCE	INTERRUPT RESET METHOD
BIT 3	BIT 2	BIT 1	BIT 0				
0	0	0	1	None	None	None	None
0	1	1	0	1	Receiver line status	Overrun error, parity error, framing error or break interrupt	Reading the line status register
0	1	0	0	2	Received data available	Receiver data available in the TL16C450 mode or trigger level reached in the FIFO mode.	Reading the receiver buffer register
1	1	0	0	2	Character timeout indication	No characters have been removed from or input to the receiver FIFO during the last four character times, and there is at least one character in it during this time	Reading the receiver buffer register
0	0	1	0	3	Transmitter holding register empty	Transmitter holding register—empty	Reading the interrupt identification register (if source of interrupt) or writing into the transmitter holding register
0	0	0	0	4	Modem status	Clear to send, data set ready, ring indicator, or data carrier detect	Reading the modem status register

**line control register (LCR)**

The system programmer controls the format of the asynchronous data communication exchange through the LCR. In addition, the programmer is able to retrieve, inspect, and modify the contents of the LCR; this eliminates the need for separate storage of the line characteristics in system memory. The contents of this register are summarized in Table 3 and are described in the following bulleted list.

- Bits 0 and 1: These two bits specify the number of bits in each transmitted or received serial character. These bits are encoded in Table 6.

**Table 6. Serial Character Word Length**

BIT 1	BIT 0	WORD LENGTH
0	0	5 bits
0	1	6 bits
1	0	7 bits
1	1	8 bits

- Bit 2: This bit specifies either one, one and one-half, or two stop bits in each transmitted character. When bit 2 is cleared, one stop bit is generated in the data. When bit 2 is set, the number of stop bits generated is dependent on the word length selected with bits 0 and 1. The receiver clocks only the first stop bit, regardless of the number of stop bits selected. The number of stop bits generated, in relation to word length and bit 2, is shown in Table 7.

**PRINCIPLES OF OPERATION**

**line control register (LCR) (continued)**

**Table 7. Number of Stop Bits Generated**

BIT 2	WORD LENGTH SELECTED BY BITS 1 AND 2	NUMBER OF STOP BITS GENERATED
0	Any word length	1
1	5 bits	1 1/2
1	6 bits	2
1	7 bits	2
1	8 bits	2

- Bit 3: This bit is the parity enable bit. When bit 3 is set, a parity bit is generated in transmitted data between the last data word bit and the first stop bit. In received data, when bit 3 is set, parity is checked. When bit 3 is cleared, no parity is generated or checked.
- Bit 4: This bit is the even parity select bit. When parity is enabled (bit 3 is set) and bit 4 is set, even parity (an even number of logic 1s in the data and parity bits) is selected. When parity is enabled and bit 4 is cleared, odd parity (an odd number of logic 1s) is selected.
- Bit 5: This is the stick parity bit. When bits 3, 4, and 5 are set, the parity bit is transmitted and checked as cleared. When bits 3 and 5 are set and bit 4 is cleared, the parity bit is transmitted and checked as set. When bit 5 is cleared, stick parity is disabled.
- Bit 6: This bit is the break control bit. Bit 6 is set to force a break condition; i.e., a condition where SOUT is forced to the spacing (cleared) state. When bit 6 is cleared, the break condition is disabled and has no affect on the transmitter logic; it only effects the serial output.
- Bit 7: This bit is the divisor latch access bit (DLAB). Bit 7 must be set to access the divisor latches of the baud generator during a read or write. Bit 7 must be cleared during a read or write to access the receiver buffer, the THR, or the IER.

**line status register (LSR)<sup>†</sup>**

The LSR provides information to the CPU concerning the status of data transfers. The contents of this register are summarized in Table 3 and are described in the following bulleted list.

- Bit 0: This bit is the data ready (DR) indicator for the receiver. Bit 0 is set whenever a complete incoming character has been received and transferred into the RBR or the FIFO. Bit 0 is cleared by reading all of the data in the RBR or the FIFO.
- Bit 1<sup>‡</sup>: This bit is the overrun error (OE) indicator. When bit 1 is set, it indicates that before the character in the RBR is read, it is overwritten by the next character transferred into the register. The OE indicator is cleared every time the CPU reads the contents of the LSR. If the FIFO mode data continues to fill the FIFO beyond the trigger level, an overrun error occurs only after the FIFO is full and the next character has been completely received in the shift register. An OE is indicated to the CPU as soon as it happens. The character in the shift register is overwritten, but it is not transferred to the FIFO.

<sup>†</sup> The line status register is intended for read operations only; writing to this register is not recommended outside of a factory testing environment.

<sup>‡</sup> Bits 1 through 4 are the error conditions that produce a receiver line status interrupt.



## PRINCIPLES OF OPERATION

### line status register (LSR) (continued)<sup>†</sup>

- Bit 2<sup>‡</sup>: This bit is the parity error (PE) indicator. When bit 2 is set, it indicates that the parity of the received data character does not match the parity selected in the LCR (bit 4). The PE bit is cleared every time the CPU reads the contents of the LSR. In the FIFO mode, this error is associated with the particular character in the FIFO to which it applies. This error is revealed to the CPU when its associated character is at the top of the FIFO.
- Bit 3<sup>‡</sup>: This bit is the framing error (FE) indicator. When bit 3 is set, it indicates that the received character did not have a valid (set) stop bit. The FE bit is cleared every time the CPU reads the contents of the LSR. In the FIFO mode, this error is associated with the particular character in the FIFO to which it applies. This error is revealed to the CPU when its associated character is at the top of the FIFO. The ACE tries to resynchronize after a framing error. To accomplish this, it is assumed that the framing error is due to the next start bit. The ACE samples this start bit twice and then accepts the input data.
- Bit 4<sup>‡</sup>: This bit is the break interrupt (BI) indicator. When bit 4 is set, it indicates that the received data input was held cleared for longer than a full-word transmission time. A full-word transmission time is defined as the total time of the start, data, parity, and stop bits. The BI bit is cleared every time the CPU reads the contents of the LSR. In the FIFO mode, this error is associated with the particular character in the FIFO to which it applies. This error is revealed to the CPU when its associated character is at the top of the FIFO. When a break occurs, only one 0 character is loaded into the FIFO. The next character transfer is enabled after SIN goes to the marking state and receives the next valid start bit.
- Bit 5: This bit is the THRE indicator. Bit 5 is set when the THR is empty, indicating that the ACE is ready to accept a new character. If the THRE interrupt is enabled when the THRE bit is set, an interrupt is generated. THRE is set when the contents of the THR are transferred to the transmitted shift register. This bit is cleared concurrent with the loading of the THR by the CPU. In the FIFO mode, this bit is set when the transmit FIFO is empty; it is cleared when at least one byte is written to the transmit FIFO.
- Bit 6: This bit is the transmitter empty (TEMT) indicator. Bit 6 is set when the THR and the TSR are both empty. When either the THR or the TSR contains a data character, the TEMT bit is cleared. In the FIFO mode, this bit is set when the transmitter FIFO and shift register are both empty.
- Bit 7: In the TL16C550B and the TL16C550BI mode, this bit is always cleared. In the TL16C450 mode, this bit is always cleared. In the FIFO mode, LSR7 is set when there is at least one parity, framing, or break error in the FIFO. It is cleared when the microprocessor reads the LSR and there are no subsequent errors in the FIFO.

### modem control register (MCR)

The MCR is an 8-bit register that controls an interface with a modem, data set, or peripheral device that is emulating a modem. The contents of this register are summarized in Table 3 and are described in the following bulleted list.

- Bit 0: This bit (DTR) controls the data terminal ready ( $\overline{DTR}$ ) output. Setting bit 0 forces the  $\overline{DTR}$  output to its low state. When bit 0 is cleared,  $\overline{DTR}$  goes high.
- Bit 1: This bit (RTS) controls the request to send ( $\overline{RTS}$ ) output in a manner identical to bit 0's control over the  $\overline{DTR}$  output.
- Bit 2: This bit (OUT1) controls the output 1 ( $\overline{OUT1}$ ) signal, a user-designated output signal, in a manner identical to bit 0's control over the  $\overline{DTR}$  output.

<sup>†</sup> The line status register is intended for read operations only; writing to this register is not recommended outside of a factory testing environment.

<sup>‡</sup> Bits 1 through 4 are the error conditions that produce a receiver line status interrupt.

# TL16C550B, TL16C550BI

## ASYNCHRONOUS COMMUNICATIONS ELEMENT

SLLS136B – JANUARY 1994 – REVISED AUGUST 1996

---

### PRINCIPLES OF OPERATION

#### modem control register (MCR) (continued)

- Bit 3: This bit (OUT2) controls the output 2 ( $\overline{\text{OUT2}}$ ) signal, a user-designated output signal, in a manner identical to bit 0's control over the  $\overline{\text{DTR}}$  output.
- Bit 4: This bit provides a local loop back feature for diagnostic testing of the ACE. When this bit is set, the following occurs:
  - The SOUT is set high.
  - The SIN is disconnected.
  - The output of the TSR is looped back into the receiver shift register input.
  - The four modem control inputs ( $\overline{\text{CTS}}$ ,  $\overline{\text{DSR}}$ ,  $\overline{\text{DCD}}$ , and  $\overline{\text{RI}}$ ) are disconnected.
  - The four modem control outputs ( $\overline{\text{DTR}}$ ,  $\overline{\text{RTS}}$ ,  $\overline{\text{OUT1}}$ , and  $\overline{\text{OUT2}}$ ) are internally connected to the four modem control inputs.
  - The four modem control outputs are forced to their inactive (high) states.

In the diagnostic mode, data that is transmitted is immediately received. This allows the processor to verify the transmit and receive data paths to the ACE. The receiver and transmitter interrupts are fully operational. The modem control interrupts are also operational, but the modem control interrupt's sources are now the lower four bits of the MCR instead of the four modem control inputs. All interrupts are still controlled by the IER.

- Bits 5 – 7: These bits are permanently cleared.

#### modem status register (MSR)

The MSR is an 8-bit register that provides information about the current state of the control lines from the modem, data set, or peripheral device to the CPU. Additionally, four bits of this register provide change information; when a control input from the modem changes state, the appropriate bit is set. All four bits are cleared when the CPU reads the MSR. The contents of this register are summarized in Table 3 and are described in the following bulleted list.

- Bit 0: This bit is the change in clear-to-send ( $\Delta\text{CTS}$ ) indicator. Bit 0 indicates that the  $\overline{\text{CTS}}$  input has changed states since the last time it was read by the CPU. When this bit is set and the modem status interrupt is enabled, a modem status interrupt is generated.
- Bit 1: This bit is the change in data set ready ( $\Delta\text{DSR}$ ) indicator. Bit 1 indicates that the  $\overline{\text{DSR}}$  input has changed states since the last time it was read by the CPU. When this bit is set and the modem status interrupt is enabled, a modem status interrupt is generated.
- Bit 2: This bit is the trailing edge of the ring indicator (TERI) detector. Bit 2 indicates that the  $\overline{\text{RI}}$  input to the chip has changed from a low to a high state. When this bit is set and the modem status interrupt is enabled, a modem status interrupt is generated.
- Bit 3: This bit is the change in data carrier detect ( $\Delta\text{DCD}$ ) indicator. Bit 3 indicates that the  $\overline{\text{DCD}}$  input to the chip has changed states since the last time it was read by the CPU. When this bit is set and the modem status interrupt is enabled, a modem status interrupt is generated.
- Bit 4: This bit is the complement of the clear-to-send ( $\overline{\text{CTS}}$ ) input. When bit 4 (loop) of the MCR is set, bit 4 is equivalent to the MCR bit 1 (RTS).
- Bit 5: This bit is the complement of the data set ready ( $\overline{\text{DSR}}$ ) input. When bit 4 (loop) of the MCR is set, bit 5 is equivalent to the MCR bit 1 (DTR).



POST OFFICE BOX 655303 • DALLAS, TEXAS 75265

## PRINCIPLES OF OPERATION

### modem status register (MSR) (continued)

- Bit 6: This bit is the complement of the ring indicator ( $\overline{RI}$ ) input. When bit 4 (loop) of the MCR is set, bit 6 is equivalent to the MCRs bit 2 (OUT1).
- Bit 7: This bit is the complement of the data carrier detect ( $\overline{DCD}$ ) input. When bit 4 (loop) of the MCR is set, bit 7 is equivalent to the MCRs bit 3 (OUT2).

### programmable baud generator

The ACE contains a programmable baud generator that takes a clock input in the range between dc and 8 MHz and divides it by a divisor in the range between 1 and ( $2^{16}-1$ ). The output frequency of the baud generator is  $16\times$  the baud rate. The formula for the divisor is:

$$\text{divisor \#} = \text{XIN frequency input} \div (\text{desired baud rate} \times 16)$$

Two 8-bit registers, called divisor latches, store the divisor in a 16-bit binary format. These divisor latches must be loaded during initialization of the ACE in order to ensure desired operation of the baud generator. When either of the divisor latches is loaded, a 16-bit baud counter is also loaded to prevent long counts on initial load.

Tables 8 and 9 illustrate the use of the baud generator with crystal frequencies of 1.8432 MHz and 3.072 MHz respectively. For baud rates of 38.4 kbit/s and below, the error obtained is very small. The accuracy of the selected baud rate is dependent on the selected crystal frequency. Refer to Figure 16 for examples of typical clock circuits.

**Table 8. Baud Rates Using a 1.8432-MHz Crystal**

DESIRED BAUD RATE	DIVISOR USED TO GENERATE $16\times$ CLOCK	PERCENT ERROR DIFFERENCE BETWEEN DESIRED AND ACTUAL
50	2304	
75	1536	
110	1047	0.026
134.5	857	0.058
150	768	
300	384	
600	192	
1200	96	
1800	64	
2000	58	0.69
2400	48	
3600	32	
4800	24	
7200	16	
9600	12	
19200	6	
38400	3	
56000	2	2.86

PRINCIPLES OF OPERATION

programmable baud generator (continued)

Table 9. Baud Rates Using a 3.072-MHz Crystal

DESIRED BAUD RATE	DIVISOR USED TO GENERATE 16× CLOCK	PERCENT ERROR DIFFERENCE BETWEEN DESIRED AND ACTUAL
50	3840	
75	2560	
110	1745	0.026
134.5	1428	0.034
150	1280	
300	640	
600	320	
1200	160	
1800	107	0.312
2000	96	
2400	80	
3600	53	0.628
4800	40	
7200	27	1.23
9600	20	
19200	10	
38400	5	

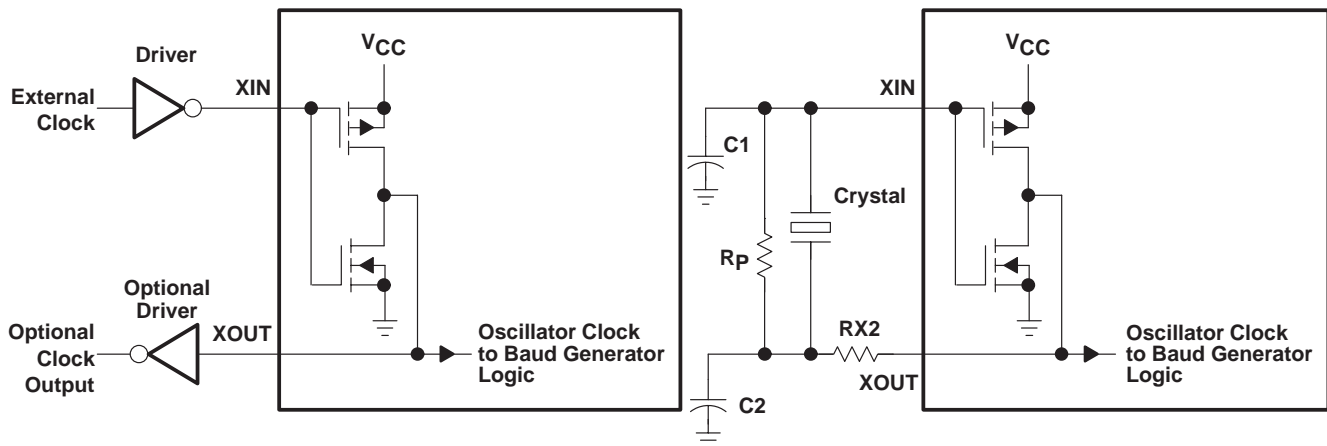

TYPICAL CRYSTAL OSCILLATOR NETWORK

CRYSTAL	R <sub>p</sub>	RX2	C1	C2
3.1 MHz	1 MΩ	1.5 kΩ	10-30 pF	40-60 pF
1.8 MHz	1 MΩ	1.5 kΩ	10-30 pF	40-60 pF

Figure 16. Typical Clock Circuits

## PRINCIPLES OF OPERATION

### receiver buffer register (RBR)

The ACE receiver section consists of a receiver shift register (RSR) and a RBR. The RBR is actually a 16-byte FIFO. Timing is supplied by the 16× receiver clock (RCLK). Receiver section control is a function of the ACE line control register.

The ACE RSR receives serial data from the SIN terminal. The RSR then deserializes the data and moves it into the RBR FIFO. In the TL16C450 mode, when a character is placed in the receiver buffer register and the received data available interrupt is enabled, an interrupt is generated. This interrupt is cleared when the data is read out of the RBR. In the FIFO mode, the interrupts are generated based on the control setup in the FIFO control register.

### scratch register

The scratch register is an 8-bit register that is intended for programmer use as a scratchpad in the sense that it temporarily holds the programmer's data without affecting any other ACE operation.

### transmitter holding register (THR)

The ACE transmitter section consists of a THR and a transmitter shift register (TSR). The THR is actually a 16-byte FIFO. Timing is supplied by the baud out (BAUDOUT) clock signal. Transmitter section control is a function of the ACE's line control register.

The ACE THR receives data off the internal data bus and when the shift register is idle, moves it into the TSR. The TSR serializes the data and outputs it at the SOUT. In the TL16C450 mode, when the THR is empty and the transmitter holding register empty (THRE) interrupt is enabled, an interrupt is generated. This interrupt is cleared when a character is loaded into the register. In the FIFO mode, the interrupts are generated based on the control setup in the FIFO control register.

# TL16C550B, TL16C550BI ASYNCHRONOUS COMMUNICATIONS ELEMENT

SLLS136B – JANUARY 1994 – REVISED AUGUST 1996

## MECHANICAL DATA

FN (S-PQCC-J\*\*)

PLASTIC J-LEADED CHIP CARRIER

20 PIN SHOWN

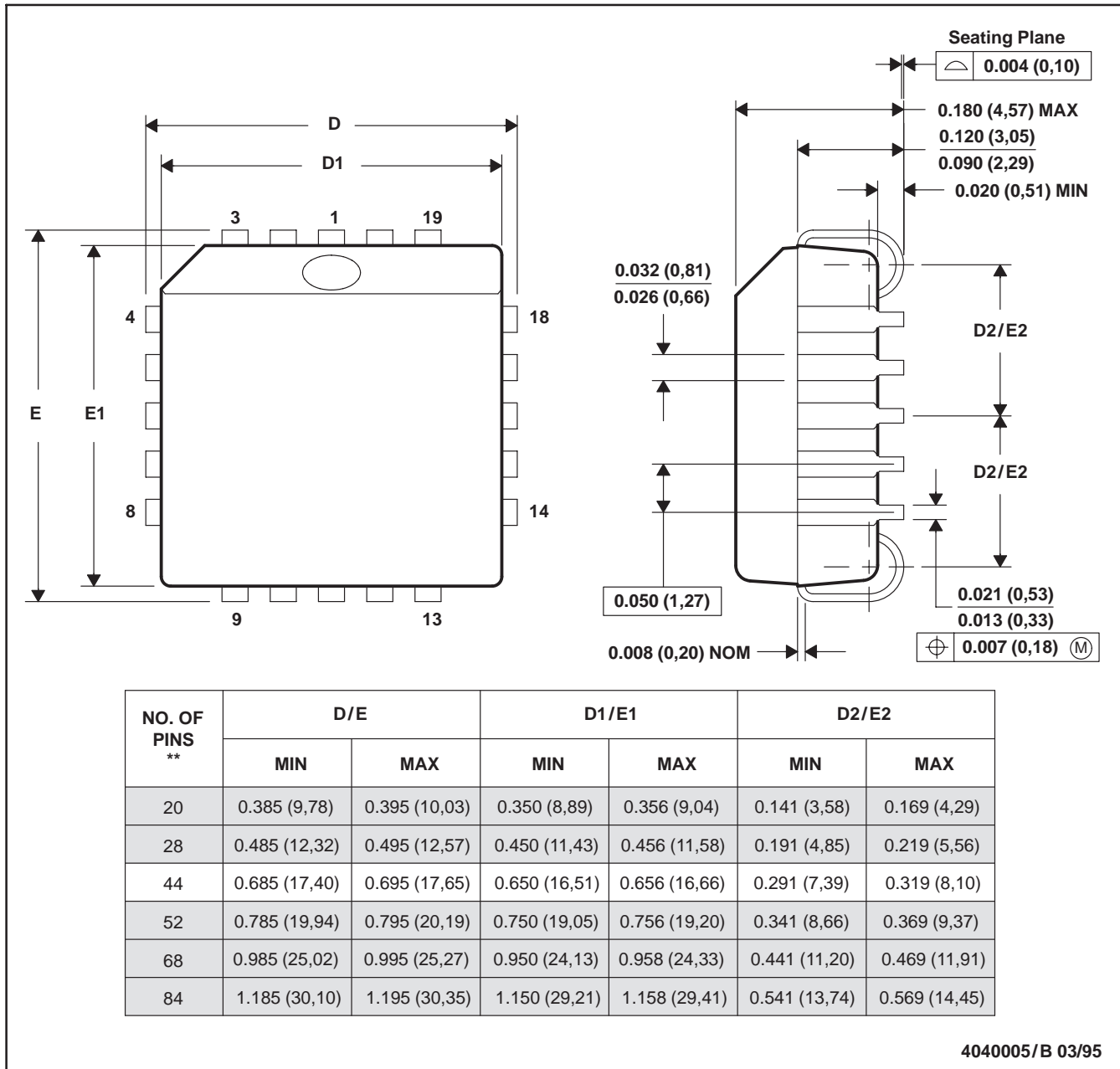

- NOTES: A. All linear dimensions are in inches (millimeters).  
 B. This drawing is subject to change without notice.  
 C. Falls within JEDEC MS-018

# TL16C550B, TL16C550BI ASYNCHRONOUS COMMUNICATIONS ELEMENT

SLLS136B – JANUARY 1994 – REVISED AUGUST 1996

## MECHANICAL DATA

**N (R-PDIP-T\*\*)**

**PLASTIC DUAL-IN-LINE PACKAGE**

24 PIN SHOWN

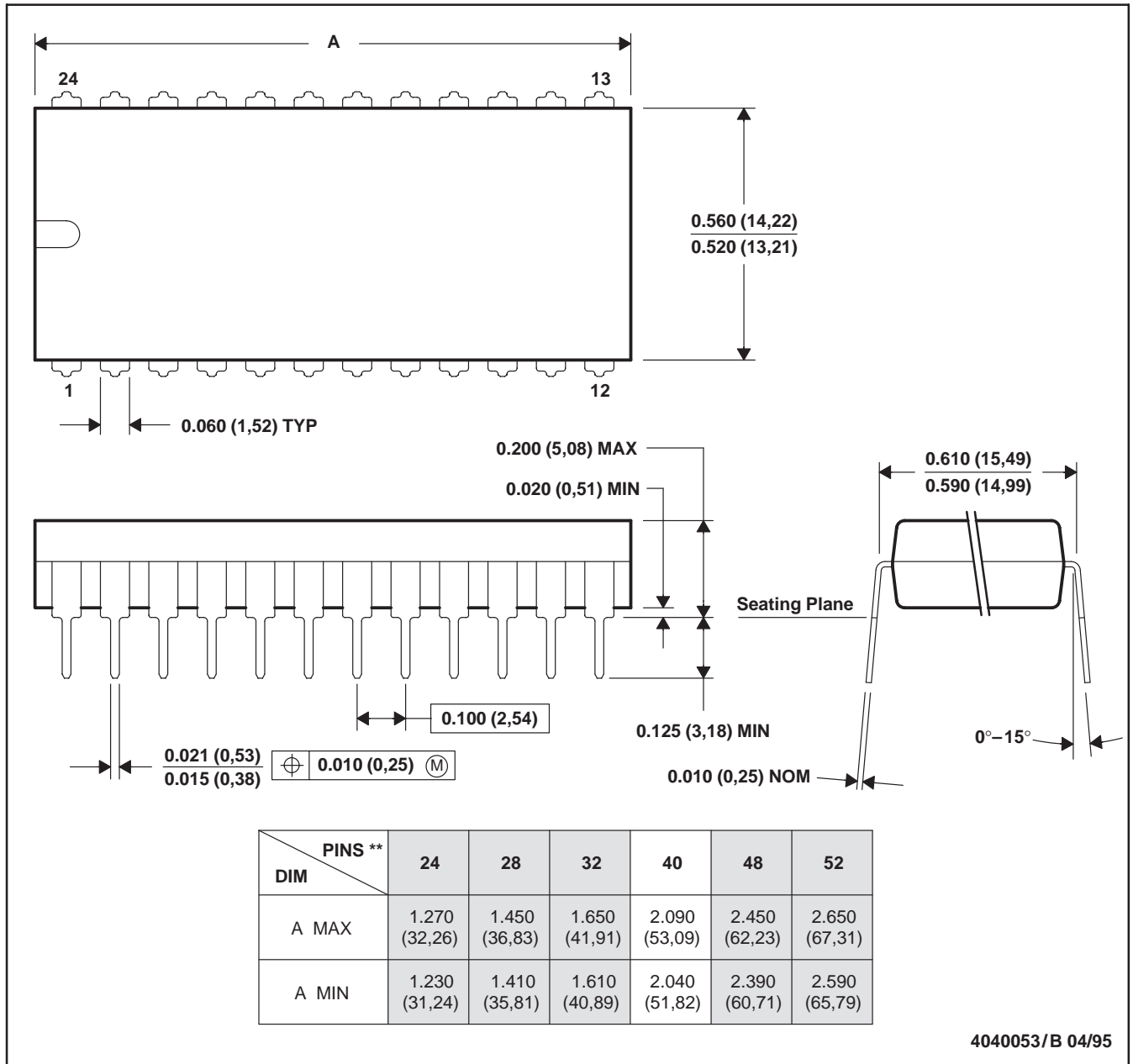

- NOTES: A. All linear dimensions are in inches (millimeters).  
 B. This drawing is subject to change without notice.  
 C. Falls within JEDEC MS-011  
 D. Falls within JEDEC MS-015 (32 pin only)

# TL16C550B, TL16C550BI ASYNCHRONOUS COMMUNICATIONS ELEMENT

SLLS136B – JANUARY 1994 – REVISED AUGUST 1996

## MECHANICAL DATA

PT (S-PQFP-G48)

PLASTIC QUAD FLATPACK

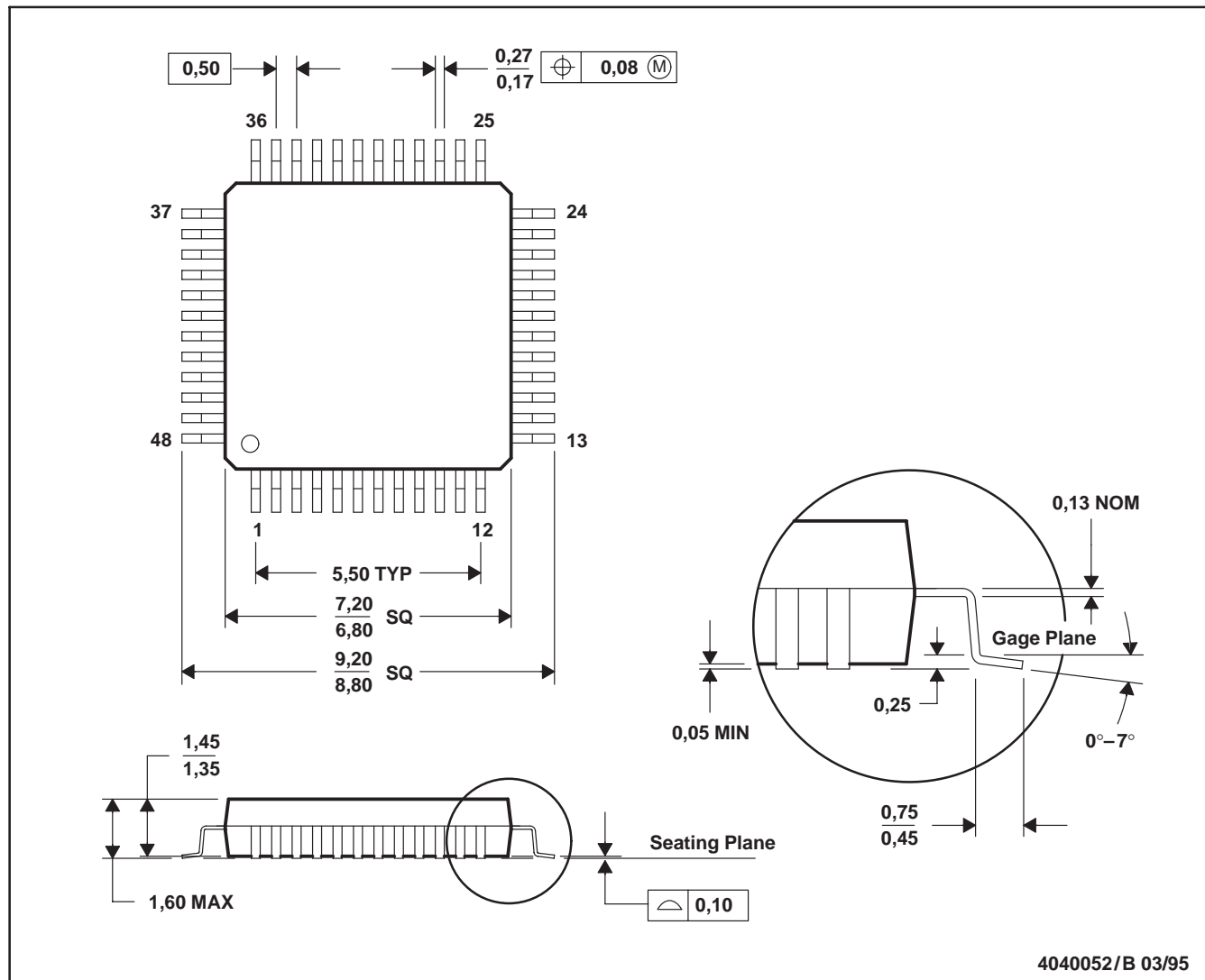

4040052/B 03/95

- NOTES:
- A. All linear dimensions are in millimeters.
  - B. This drawing is subject to change without notice.
  - C. Falls within JEDEC MO-136
  - D. This may also be a thermally-enhanced plastic package with leads connected to the die pads.

## **IMPORTANT NOTICE**

Texas Instruments (TI) reserves the right to make changes to its products or to discontinue any semiconductor product or service without notice, and advises its customers to obtain the latest version of relevant information to verify, before placing orders, that the information being relied on is current and complete.

TI warrants performance of its semiconductor products and related software to the specifications applicable at the time of sale in accordance with TI's standard warranty. Testing and other quality control techniques are utilized to the extent TI deems necessary to support this warranty. Specific testing of all parameters of each device is not necessarily performed, except those mandated by government requirements.

Certain applications using semiconductor products may involve potential risks of death, personal injury, or severe property or environmental damage ("Critical Applications").

**TI SEMICONDUCTOR PRODUCTS ARE NOT DESIGNED, INTENDED, AUTHORIZED, OR WARRANTED TO BE SUITABLE FOR USE IN LIFE-SUPPORT APPLICATIONS, DEVICES OR SYSTEMS OR OTHER CRITICAL APPLICATIONS.**

Inclusion of TI products in such applications is understood to be fully at the risk of the customer. Use of TI products in such applications requires the written approval of an appropriate TI officer. Questions concerning potential risk applications should be directed to TI through a local SC sales office.

In order to minimize risks associated with the customer's applications, adequate design and operating safeguards should be provided by the customer to minimize inherent or procedural hazards.

TI assumes no liability for applications assistance, customer product design, software performance, or infringement of patents or services described herein. Nor does TI warrant or represent that any license, either express or implied, is granted under any patent right, copyright, mask work right, or other intellectual property right of TI covering or relating to any combination, machine, or process in which such semiconductor products or services might be or are used.

## Looking for pricing, stock, or lifecycle information?

Click below to explore more details on WIN SOURCE:

 [View TL16C550BPT on WIN SOURCE](#)

 [Texas Instruments](#) Information

## Optimize Your Supply Chain with WIN SOURCE Solutions

-  Global Sourcing Solution
-  Obsolete Management
-  Cost Control Management
-  Shortage Management
-  Alternative Solution
-  Excess Inventory Management