



# THE DATASHEET OF TL594CPWR



## TL594 Pulse-Width-Modulation Control Circuit

### 1 Features

- Complete PWM Power-Control Circuitry
- Uncommitted Outputs for 200-mA Sink or Source Current
- Output Control Selects Single-Ended or Push-Pull Operation
- Internal Circuitry Prohibits Double Pulse at Either Output
- Variable Dead Time Provides Control Over Total Range
- Internal Regulator Provides a Stable 5-V Reference Supply Trimmed to 1%
- Circuit Architecture Allows Easy Synchronization
- Undervoltage Lockout (UVLO) for Low- $V_{CC}$  Conditions

### 2 Applications

- White Goods
- Power Supplies: AC/DC, Isolated, With PFC, > 90 W
- Server PSUs
- Solar Micro-Inverters
- Power Supplies: AC/DC, Isolated, No PFC, < 90 W
- Power: Telecom/Server AC/DC Supplies
- Solar Power Inverters

### 3 Description

The TL594 device incorporates all the functions required in the construction of a pulse-width-modulation (PWM) control circuit on a single chip. Designed primarily for power-supply control, this device offers the systems engineer the flexibility to tailor the power-supply control circuitry to a specific application.

The TL594 device contains two error amplifiers, an on-chip adjustable oscillator, a dead-time control (DTC) comparator, a pulse-steering control flip-flop, a 5-V regulator with a precision of 1%, an undervoltage lockout control circuit, and output control circuitry.

The uncommitted output transistors provide either common-emitter or emitter-follower output capability. Each device provides for push-pull or single-ended output operation, with selection by means of the output-control function. The architecture of these devices prohibits the possibility of either output being pulsed twice during push-pull operation. The undervoltage lockout control circuit locks the outputs off until the internal circuitry is operational.

#### Device Information

PART NUMBER	PACKAGE	BODY SIZE (NOM)
TL594D	SOIC (16)	9.90 mm × 3.91 mm
TL594N	PDIP (16)	19.30 mm × 6.35 mm
TL594NS	SO (16)	10.30 mm × 5.30 mm
TL594PW	TSSOP (16)	5.00 mm × 4.40 mm

#### Block Diagram

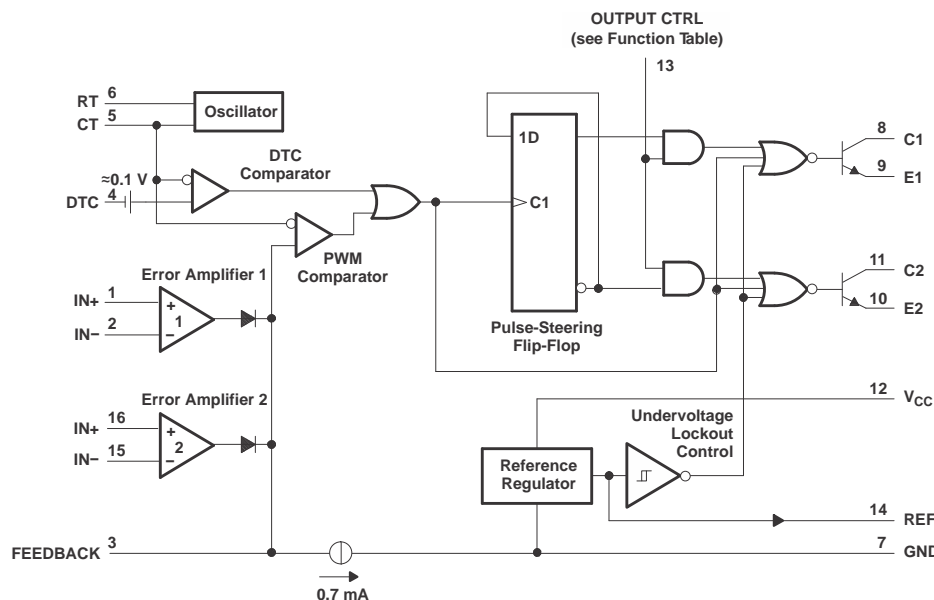

Copyright © 2016, Texas Instruments Incorporated

For OUTPUT CTRL function, see [Table 1](#).



## Table of Contents

<b>1 Features</b> .....	<b>1</b>	8.3 Feature Description .....	<b>10</b>
<b>2 Applications</b> .....	<b>1</b>	8.4 Device Functional Modes .....	<b>12</b>
<b>3 Description</b> .....	<b>1</b>	<b>9 Application and Implementation</b> .....	<b>13</b>
<b>4 Revision History</b> .....	<b>2</b>	9.1 Application Information .....	<b>13</b>
<b>5 Pin Configuration and Functions</b> .....	<b>3</b>	9.2 Typical Application .....	<b>13</b>
<b>6 Specifications</b> .....	<b>4</b>	<b>10 Power Supply Recommendations</b> .....	<b>19</b>
6.1 Absolute Maximum Ratings .....	<b>4</b>	<b>11 Layout</b> .....	<b>19</b>
6.2 ESD Ratings .....	<b>4</b>	11.1 Layout Guidelines .....	<b>19</b>
6.3 Recommended Operating Conditions .....	<b>4</b>	11.2 Layout Example .....	<b>20</b>
6.4 Thermal Information .....	<b>4</b>	<b>12 Device and Documentation Support</b> .....	<b>21</b>
6.5 Electrical Characteristics .....	<b>5</b>	12.1 Documentation Support .....	<b>21</b>
6.6 Switching Characteristics .....	<b>6</b>	12.2 Receiving Notification of Documentation Updates .....	<b>21</b>
6.7 Typical Characteristics .....	<b>6</b>	12.3 Community Resources .....	<b>21</b>
<b>7 Parameter Measurement Information</b> .....	<b>7</b>	12.4 Trademarks .....	<b>21</b>
<b>8 Detailed Description</b> .....	<b>9</b>	12.5 Electrostatic Discharge Caution .....	<b>21</b>
8.1 Overview .....	<b>9</b>	12.6 Glossary .....	<b>21</b>
8.2 Functional Block Diagram .....	<b>9</b>	<b>13 Mechanical, Packaging, and Orderable Information</b> .....	<b>21</b>

## 4 Revision History

NOTE: Page numbers for previous revisions may differ from page numbers in the current version.

<b>Changes from Revision H (January 2014) to Revision I</b>	<b>Page</b>
• Added <i>Applications</i> section, <i>ESD Ratings</i> table, <i>Feature Description</i> section, <i>Device Functional Modes</i> , <i>Application and Implementation</i> section, <i>Power Supply Recommendations</i> section, <i>Layout</i> section, <i>Device and Documentation Support</i> section, and <i>Mechanical, Packaging, and Orderable Information</i> section .....	<b>1</b>
• Changed values in the <i>Thermal Information</i> table from 73 to 73.5 (D), from 67 to 43.5 (N), from 64 to 73.6 (NS), and from 108 to 101.5 (PW) .....	<b>4</b>

<b>Changes from Revision G (January 2007) to Revision H</b>	<b>Page</b>
• Deleted Ordering Information table; see POA at the end of the data sheet .....	<b>1</b>
• Updated document to new TI data sheet format - no specific changes .....	<b>1</b>
• Added ESD warning .....	<b>1</b>

## 5 Pin Configuration and Functions

**D, N, NS, or PW Package  
16-Pin SOIC, PDIP, SO, or TSSOP  
Top View**

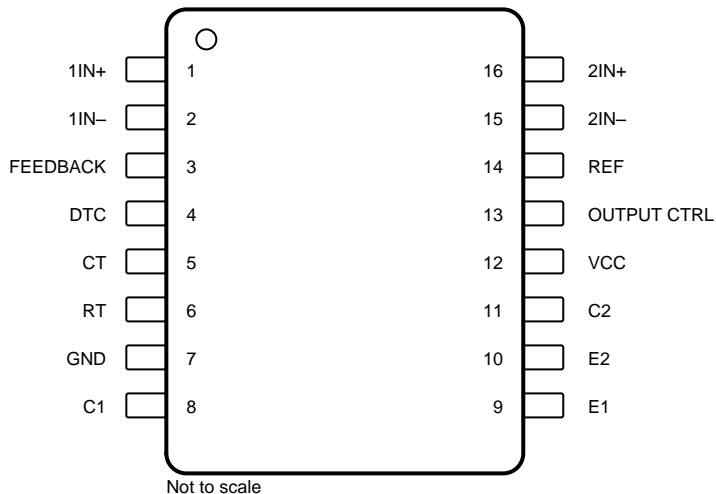

### Pin Functions

PIN		I/O	DESCRIPTION
NO.	NAME		
1	1IN+	I	Noninverting input to error amplifier 1
2	1IN–	I	Inverting input to error amplifier 1
3	FEEDBACK	I	Input pin for feedback
4	DTC	I	Dead-time control comparator input
5	CT	—	Capacitor terminal used to set oscillator frequency
6	RT	—	Resistor terminal used to set oscillator frequency
7	GND	—	Ground
8	C1	O	Collector terminal of BJT output 1
9	E1	O	Emitter terminal of BJT output 1
10	E2	O	Emitter terminal of BJT output 2
11	C2	O	Collector terminal of BJT output 2
12	V <sub>CC</sub>	—	Positive supply
13	OUTPUT CTRL	I	Selects single-ended, parallel output, or push-pull operation
14	REF	O	5-V reference regulator output
15	2IN–	I	Inverting input to error amplifier 2
16	2IN+	I	Noninverting input to error amplifier 2

## 6 Specifications

### 6.1 Absolute Maximum Ratings

over operating free-air temperature range (unless otherwise noted)<sup>(1)</sup>

	MIN	MAX	UNIT
Supply voltage, $V_{CC}$ <sup>(2)</sup>		41	V
Amplifier input voltage		$V_{CC} + 0.3$	V
Collector output voltage		41	V
Collector output current		250	mA
Operating junction temperature, $T_J$		150	°C
Storage temperature, $T_{stg}$	-65	150	°C

- (1) Stresses beyond those listed under *Absolute Maximum Ratings* may cause permanent damage to the device. These are stress ratings only, which do not imply functional operation of the device at these or any other conditions beyond those indicated under *Recommended Operating Conditions*. Exposure to absolute-maximum-rated conditions for extended periods may affect device reliability.
- (2) All voltage values, except differential voltages, are with respect to the network ground terminal.

### 6.2 ESD Ratings

		VALUE	UNIT
$V_{(ESD)}$ Electrostatic discharge	Human-body model (HBM), per ANSI/ESDA/JEDEC JS-001 <sup>(1)</sup>	1000	V
	Charged-device model (CDM), per JEDEC specification JESD22-C101 <sup>(2)</sup>	1000	

- (1) JEDEC document JEP155 states that 500-V HBM allows safe manufacturing with a standard ESD control process.
- (2) JEDEC document JEP157 states that 250-V CDM allows safe manufacturing with a standard ESD control process.

### 6.3 Recommended Operating Conditions

		MIN	MAX	UNIT	
$V_{CC}$	Supply voltage	7	40	V	
$V_I$	Amplifier input voltage	-0.3	$V_{CC} - 2$	V	
$V_O$	Collector output voltage		40	V	
	Collector output current (each transistor)		200	mA	
	Current into FEEDBACK terminal		0.3	mA	
$C_T$	Timing capacitor	0.47	10000	nF	
$R_T$	Timing resistor	1.8	500	k $\Omega$	
$f_{osc}$	Oscillator frequency	1	300	kHz	
$T_A$	Operating free-air temperature	TL594C	0	70	°C
		TL594I	-40	85	

### 6.4 Thermal Information

THERMAL METRIC <sup>(1)</sup>	TL594				UNIT	
	D (SOIC)	N (PDIP)	NS (SO)	PW (TSSOP)		
	16 PINS	16 PINS	16 PINS	16 PINS		
$R_{\theta JA}$	Junction-to-ambient thermal resistance	73.5	43.5	73.6	101.5	°C/W
$R_{\theta JC(top)}$	Junction-to-case (top) thermal resistance	32.8	30.6	30.3	29.4	°C/W
$R_{\theta JB}$	Junction-to-board thermal resistance	30.8	23.5	34.4	47.3	°C/W
$\Psi_{JT}$	Junction-to-top characterization parameter	6.1	15.3	3.4	1.4	°C/W
$\Psi_{JB}$	Junction-to-board characterization parameter	30.6	23.4	34.1	46.6	°C/W

- (1) For more information about traditional and new thermal metrics, see the [Semiconductor and IC Package Thermal Metrics](#) application report.

## 6.5 Electrical Characteristics

 $V_{CC} = 15\text{ V}$ , over recommended operating free-air temperature range (unless otherwise noted)

PARAMETER	TEST CONDITIONS <sup>(1)</sup>	MIN	TYP <sup>(2)</sup>	MAX	UNIT
<b>REFERENCE</b>					
Output voltage (REF)	$I_O = 1\text{ mA}$ , $T_A = 25^\circ\text{C}$	4.95	5	5.05	V
Input regulation	$V_{CC} = 7\text{ V to }40\text{ V}$ , $T_A = 25^\circ\text{C}$		2	25	mV
Output regulation	$I_O = 1\text{ mA to }10\text{ mA}$ , $T_A = 25^\circ\text{C}$		14	35	mV
Output-voltage change with temperature	$\Delta T_A = \text{MIN to MAX}$		2	10	mV/V
Short-circuit output current <sup>(3)</sup>	$V_{ref} = 0$	10	35	50	mA
<b>AMPLIFIER (SEE Figure 3)</b>					
Input offset voltage, error amplifier	FEEDBACK = 2.5 V		2	10	mV
Input offset current	FEEDBACK = 2.5 V		25	250	nA
Input bias current	FEEDBACK = 2.5 V		0.2	1	$\mu\text{A}$
Common mode input voltage, error amplifier	$V_{CC} = 7\text{ V to }40\text{ V}$	0.3 to $V_{CC} - 2$			V
Open-loop voltage amplification, error amplifier	$\Delta V_O = 3\text{ V}$ , $R_L = 2\text{ k}\Omega$ , $V_O = 0.5\text{ V to }3.5\text{ V}$	70	95		dB
Unity-gain bandwidth	$V_O = 0.5\text{ V to }3.5\text{ V}$ , $R_L = 2\text{ k}\Omega$		800		kHz
Common mode rejection ratio, error amplifier	$V_{CC} = 40\text{ V}$ , $T_A = 25^\circ\text{C}$	65	80		dB
Output sink current, FEEDBACK	$V_{ID} = -15\text{ mV to }-5\text{ V}$ , FEEDBACK = 0.5 V	0.3	0.7		mA
Output source current, FEEDBACK	$V_{ID} = 15\text{ mV to }5\text{ V}$ , FEEDBACK = 3.5 V	-2			mA
<b>OSCILLATOR, <math>C_T = 0.01\ \mu\text{F}</math>, <math>R_T = 12\text{ k}\Omega</math> (SEE Figure 4)</b>					
Frequency			10		kHz
Standard deviation of frequency <sup>(4)</sup>	All values of $V_{CC}$ , $C_T$ , $R_T$ , and $T_A$ constant		100		Hz/kHz
Frequency change with voltage	$V_{CC} = 7\text{ V to }40\text{ V}$ , $T_A = 25^\circ\text{C}$		1		Hz/kHz
Frequency change with temperature <sup>(5)</sup>	$\Delta T_A = \text{MIN to MAX}$			50	Hz/kHz
<b>DEAD-TIME CONTROL (SEE Figure 4)</b>					
Input bias current	$V_I = 0\text{ to }5.25\text{ V}$		-2	-10	$\mu\text{A}$
Maximum duty cycle, each output	DTC = 0 V	0.45			
Input threshold voltage	Zero duty cycle		3	3.3	V
	Maximum duty cycle	0			
<b>OUTPUT</b>					
Collector off-state current	$V_C = 40\text{ V}$ , $V_E = 0\text{ V}$ , $V_{CC} = 40\text{ V}$		2	100	$\mu\text{A}$
	DTC and OUTPUT CTRL = 0 V, $V_C = 15\text{ V}$ , $V_E = 0\text{ V}$ , $V_{CC} = 1\text{ V to }3\text{ V}$		4	200	
Emitter off-state current	$V_{CC} = V_C = 40\text{ V}$ , $V_E = 0$			-100	$\mu\text{A}$
Collector-emitter saturation voltage	Common emitter, $V_E = 0$ , $I_C = 200\text{ mA}$		1.1	1.3	V
	Emitter follower, $V_C = 15\text{ V}$ , $I_E = -200\text{ mA}$		1.5	2.5	
Output control input current	$V_I = V_{ref}$			3.5	mA

(1) For conditions shown as MIN or MAX, use the appropriate value specified under recommended operating conditions.

(2) All typical values, except for parameter changes with temperature, are at  $T_A = 25^\circ\text{C}$ .

(3) Duration of the short circuit must not exceed one second.

(4) Standard deviation is a measure of the statistical distribution about the mean, as derived from the formula:

$$\sigma = \sqrt{\frac{\sum_{n=1}^N (X_n - \bar{X})^2}{N - 1}}$$

(5) Temperature coefficient of timing capacitor and timing resistor is not taken into account.

### Electrical Characteristics (continued)

$V_{CC} = 15\text{ V}$ , over recommended operating free-air temperature range (unless otherwise noted)

PARAMETER	TEST CONDITIONS <sup>(1)</sup>	MIN	TYP <sup>(2)</sup>	MAX	UNIT
<b>PWM COMPARATOR (SEE Figure 4)</b>					
Input threshold voltage, FEEDBACK	Zero duty cycle		4	4.5	V
Input sink current, FEEDBACK	FEEDBACK = 0.5 V	0.3	0.7		mA
<b>UNDERVOLTAGE LOCKOUT (SEE Figure 4)</b>					
Threshold voltage	$T_A = 25^\circ\text{C}$			6	V
	$\Delta T_A = \text{MIN to MAX}$	3.5		6.9	
Hysteresis <sup>(6)</sup>		100			mV
<b>OVERALL DEVICE</b>					
Standby supply current	$R_T$ at $V_{ref}$ , All other inputs and outputs open	$V_{CC} = 15\text{ V}$	9	15	mA
		$V_{CC} = 40\text{ V}$	11	18	
Average supply current	DTC = 2 V, see Figure 4		12.4		mA

(6) Hysteresis is the difference between the positive-going input threshold voltage and the negative-going input threshold voltage.

### 6.6 Switching Characteristics

$V_{CC} = 15\text{ V}$ ,  $T_A = 25^\circ\text{C}$ , over recommended operating conditions (unless otherwise noted)

PARAMETER	TEST CONDITIONS	MIN	TYP	MAX	UNIT
Output-voltage rise time	Common-emitter configuration (see Figure 5)		100	200	ns
Output-voltage fall time	Common-emitter configuration (see Figure 5)		30	100	ns
Output-voltage rise time	Emitter-follower configuration (see Figure 6)		200	400	ns
Output-voltage fall time	Emitter-follower configuration (see Figure 6)		45	100	ns

### 6.7 Typical Characteristics

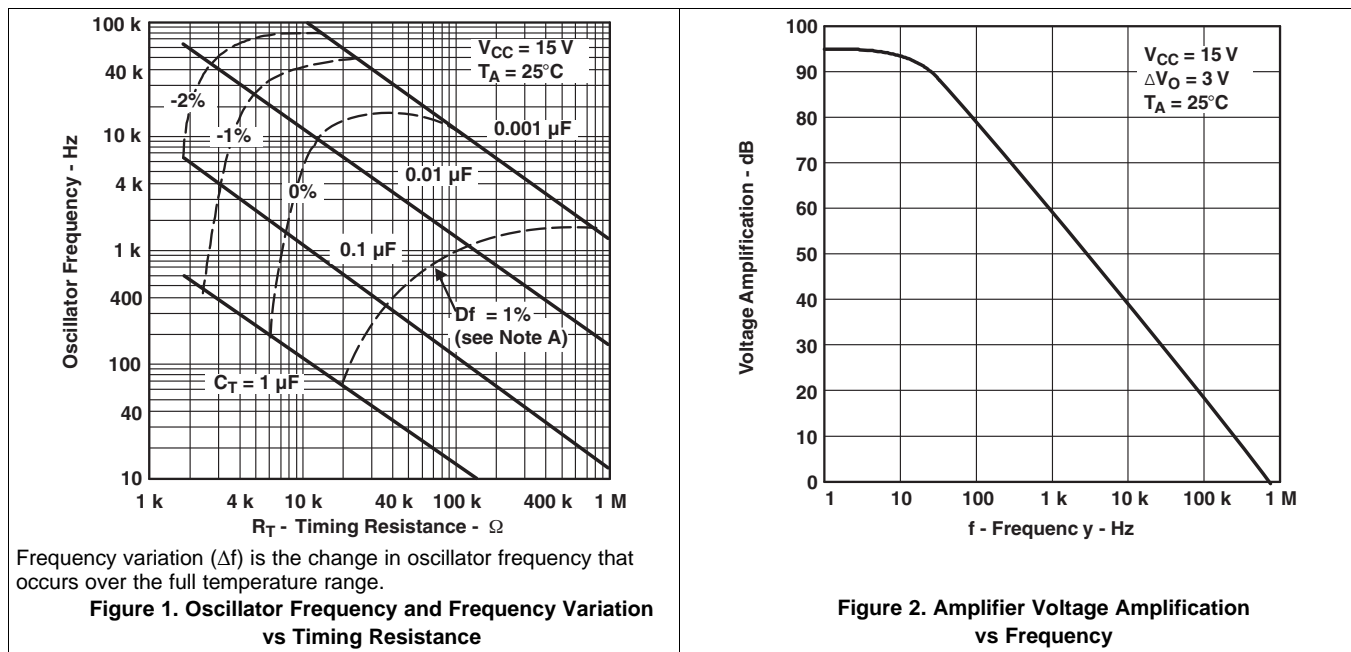

## 7 Parameter Measurement Information

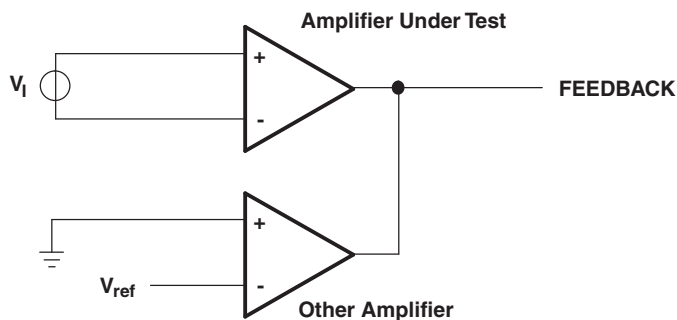

Figure 3. Amplifier-Characteristics Test Circuit

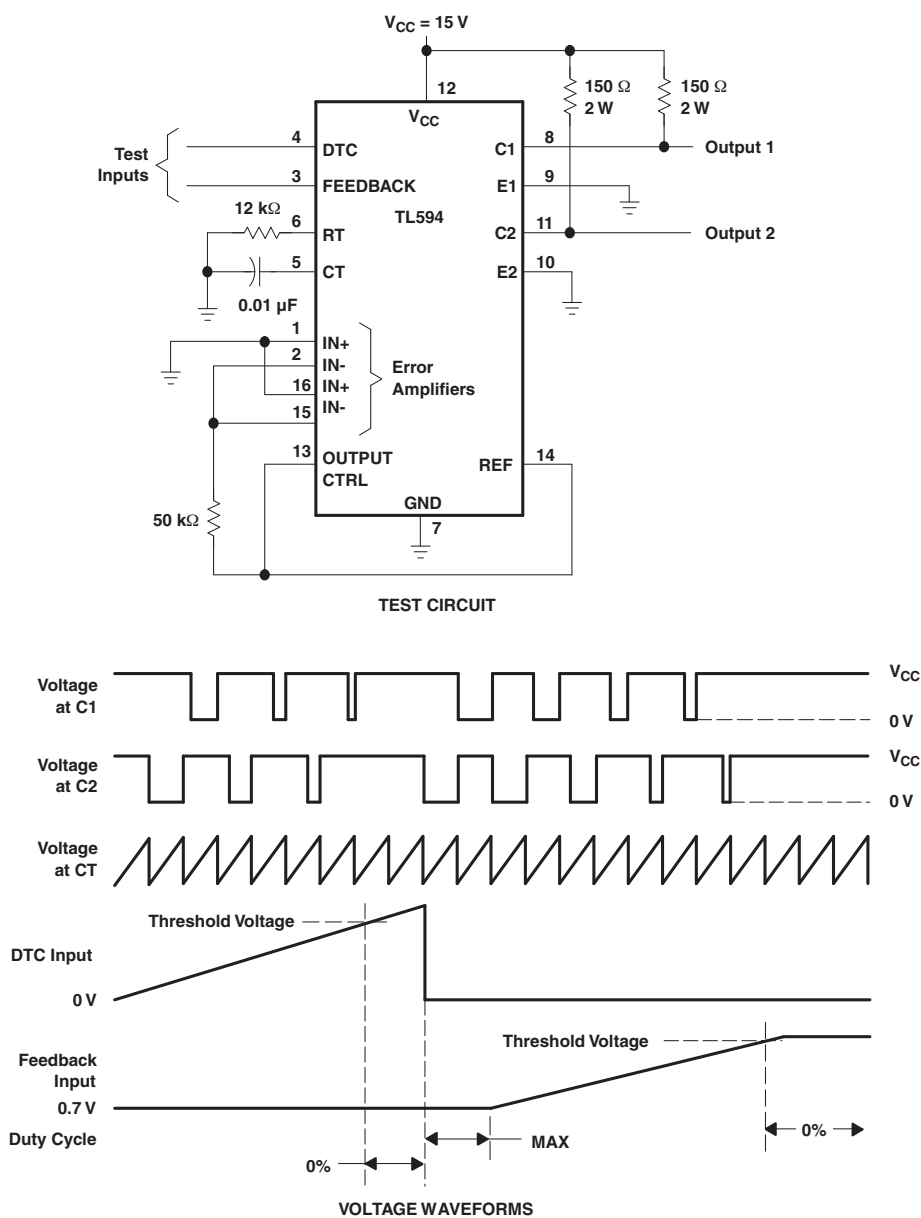
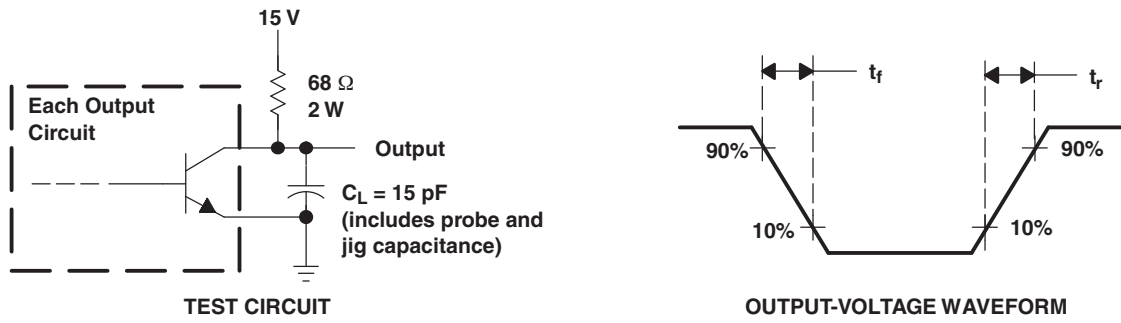
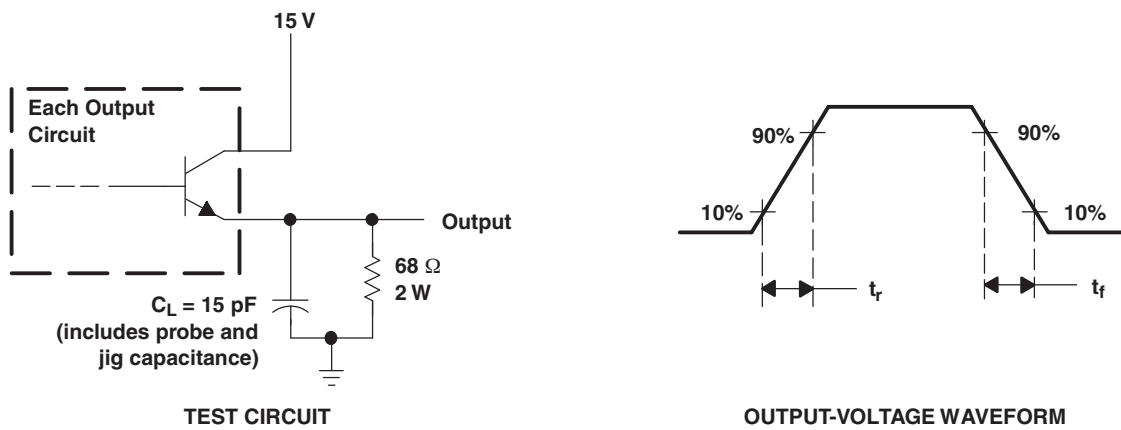

Figure 4. Operational Test Circuit and Waveforms

**Parameter Measurement Information (continued)**



**Figure 5. Common-Emitter Configuration**



**Figure 6. Emitter-Follower Configuration**

## 8 Detailed Description

### 8.1 Overview

The design of the TL594 not only incorporates the primary building blocks required to control a switching power supply, but also addresses many basic problems and reduces the amount of additional circuitry required in the total design. The TL594 is a fixed-frequency pulse-width-modulation (PWM) control circuit. Modulation of output pulses is accomplished by comparing the sawtooth waveform created by the internal oscillator on the timing capacitor (CT) to either of two control signals. The output stage is enabled during the time when the sawtooth voltage is greater than the voltage control signals. As the control signal increases, the time during which the sawtooth input is greater decreases; therefore, the output pulse duration decreases. A pulse-steering flip-flop alternately directs the modulated pulse to each of the two output transistors.

The error amplifiers have a common-mode voltage range of  $-0.3\text{ V}$  to  $V_{CC} - 2\text{ V}$ . The DTC comparator has a fixed offset that provides approximately 5% dead time. The on-chip oscillator can be bypassed by terminating RT to the reference output and providing a sawtooth input to CT, or it can be used to drive the common circuitry in synchronous multiple-rail power supplies. For more information on the operation of the TL594, see [Designing Switching Voltage Regulators With the TL494](#) (SLVA001).

### 8.2 Functional Block Diagram

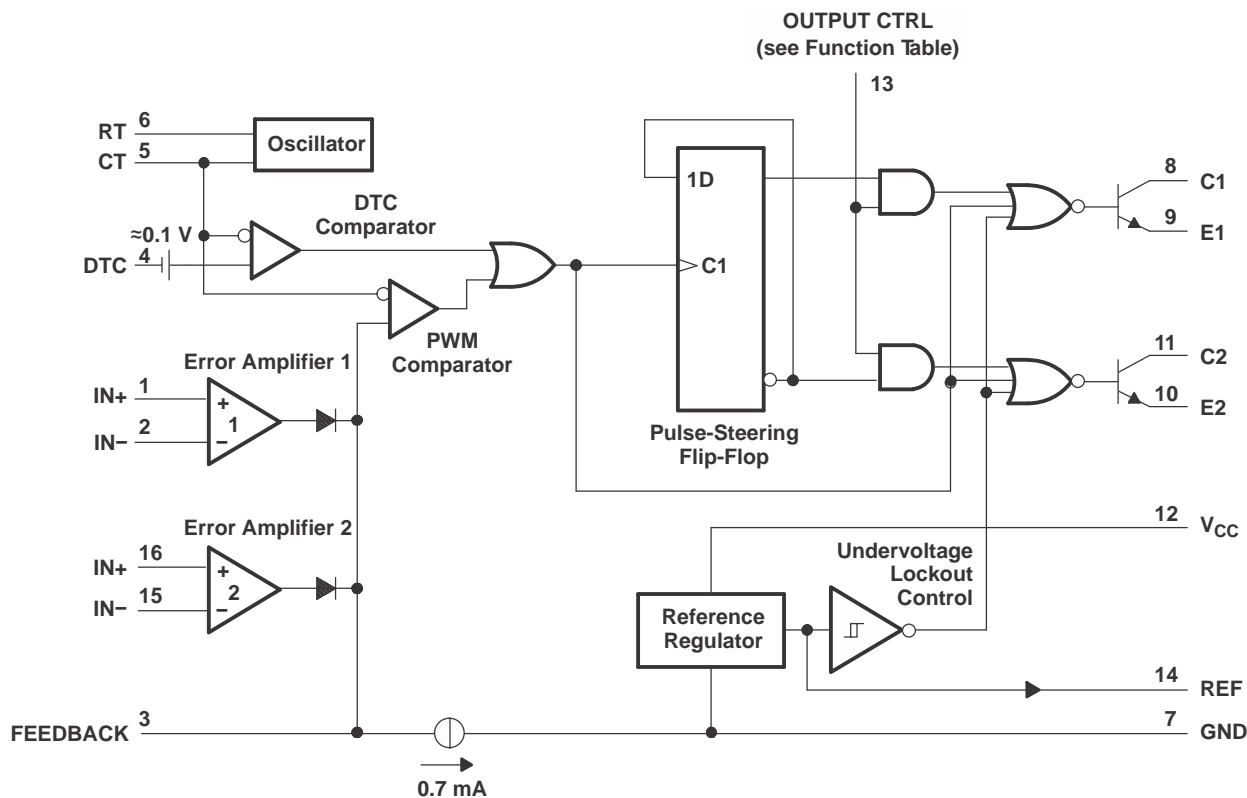

Copyright © 2016, Texas Instruments Incorporated

For OUTPUT CTRL function, see [Table 1](#).

## 8.3 Feature Description

### 8.3.1 5-V Reference Regulator

The TL594 internal 5-V reference regulator output is the REF pin. In addition to providing a stable reference, it acts as a preregulator and establishes a stable supply from which the output-control logic, pulse-steering flip-flop, oscillator, dead-time control comparator, and PWM comparator are powered. The regulator employs a band-gap circuit as its primary reference to maintain thermal stability of less than 100-mV variation over the operating free-air temperature range of 0°C to 70°C. Short-circuit protection is provided to protect the internal reference and preregulator; 10 mA of load current is available for additional bias circuits. The reference is internally programmed to an initial accuracy of  $\pm 1\%$  and maintains a stability of less than 25-mV variation over an input voltage range of 7 V to 40 V. For input voltages less than 7 V, the regulator saturates within 1 V of the input and tracks it.

### 8.3.2 Undervoltage Lockout

The TL594 has circuitry to provide an undervoltage-lockout functionality. A minimum recommended  $V_{CC}$  voltage of 7 V is recommended for operation, but if the  $V_{CC}$  voltage drops below 6 V during operation, then the device shuts off. See [Electrical Characteristics](#) for additional information regarding the undervoltage lockout circuitry.

### 8.3.3 Oscillator

The oscillator provides a positive sawtooth waveform to the dead-time and PWM comparators for comparison to the various control signals.

The frequency of the oscillator is programmed by selecting timing components  $R_T$  and  $C_T$ . The oscillator charges the external timing capacitor,  $C_T$ , with a constant current, the value of which is determined by the external timing resistor,  $R_T$ . This produces a linear-ramp voltage waveform. When the voltage across  $C_T$  reaches 3 V, the oscillator circuit discharges it, and the charging cycle is reinitiated. The charging current is determined by [Equation 1](#).

$$I_{\text{CHARGE}} = \frac{3\text{ V}}{R_T} \quad (1)$$

The period of the sawtooth waveform is [Equation 2](#).

$$T = \frac{3\text{ V} \times C_T}{I_{\text{CHARGE}}} \quad (2)$$

The frequency of the oscillator becomes [Equation 3](#).

$$f_{\text{OSC}} = \frac{1}{R_T \times C_T} \quad (3)$$

However, the oscillator frequency is equal to the output frequency only for single-ended applications. For push-pull applications, the output frequency is one-half the oscillator frequency.

Single-ended applications are calculated with [Equation 4](#).

$$f = \frac{1}{R_T \times C_T} \quad (4)$$

Push-pull applications are calculated with [Equation 5](#).

$$f = \frac{1}{2R_T \times C_T} \quad (5)$$

## Feature Description (continued)

### 8.3.4 Dead-Time Control

The dead-time control input provides control of the minimum dead time (off time). The output of the comparator inhibits switching transistors Q1 and Q2 when the voltage at the input is greater than the ramp voltage of the oscillator. An internal offset of 110 mV ensures a minimum dead time of approximately 3% with the dead-time control input grounded. Applying a voltage to the dead-time control input can impose additional dead time. This provides a linear control of the dead time from its minimum of 3% to 100% as the input voltage is varied from 0 V to 3.3 V, respectively. With full-range control, the output can be controlled from external sources without disrupting the error amplifiers. The dead-time control input is a relatively high-impedance input ( $I_I < 10 \mu\text{A}$ ) and must be used where additional control of the output duty cycle is required. However, for proper control, the input must be terminated. An open circuit is an undefined condition.

### 8.3.5 Comparator

The comparator is biased from the 5-V reference regulator. This provides isolation from the input supply for improved stability. The input of the comparator does not exhibit hysteresis, so protection against false triggering near the threshold must be provided. The comparator has a response time of 400 ns from either of the control-signal inputs to the output transistors, with only 100 mV of overdrive. This ensures positive control of the output within one-half cycle for operation within the recommended 300-kHz range.

### 8.3.6 Pulse-Width Modulation (PWM)

The comparator also provides modulation control of the output pulse width. For this, the ramp voltage across timing capacitor  $C_T$  is compared to the control signal present at the output of the error amplifiers. The timing capacitor input incorporates a series diode that is omitted from the control signal input. This requires the control signal (error amplifier output) to be approximately 0.7 V greater than the voltage across  $C_T$  to inhibit the output logic, and ensures maximum duty cycle operation without requiring the control voltage to sink to a true ground potential. The output pulse width varies from 97% of the period to 0 as the voltage present at the error amplifier output varies from 0.5 V to 3.5 V, respectively.

### 8.3.7 Error Amplifiers

Both high-gain error amplifiers receive their bias from the  $V_I$  supply rail. This permits a common-mode input voltage range from  $-0.3 \text{ V}$  to 2 V less than  $V_I$ . Both amplifiers behave characteristically of a single-ended single-supply amplifier, in that each output is active high only. This allows each amplifier to pull up independently for a decreasing output pulse-width demand. With both outputs ORed together at the inverting input node of the PWM comparator, the amplifier demanding the minimum pulse out dominates. The amplifier outputs are biased low by a current sink to provide maximum pulse width out when both amplifiers are biased off.

### 8.3.8 Output-Control Input

The output-control input determines whether the output transistors operate in parallel or push-pull. This input is the supply source for the pulse-steering flip-flop. The output-control input is asynchronous and has direct control over the output, independent of the oscillator or pulse-steering flip-flop. The input condition is intended to be a fixed condition that is defined by the application. For parallel operation, the output-control input must be grounded. This disables the pulse-steering flip-flop and inhibits its outputs. In this mode, the pulses seen at the output of the dead-time control or PWM comparator are transmitted by both output transistors in parallel. For push-pull operation, the output-control input must be connected to the internal 5-V reference regulator. Under this condition, each of the output transistors is enabled, alternately, by the pulse-steering flip-flop.

### 8.3.9 Output Transistors

Two output transistors are available on the TL594. Both transistors are configured as open collector/open emitter, and each is capable of sinking or sourcing up to 200 mA. The transistors have a saturation voltage of less than 1.3 V in the common-emitter configuration and less than 2.5 V in the emitter-follower configuration. The outputs are protected against excessive power dissipation to prevent damage, but do not employ sufficient current limiting to allow them to be operated as current-source outputs.

## 8.4 Device Functional Modes

When the OUTPUT CTRL pin is tied to ground, the TL594 is operating in single-ended or parallel mode. When the OUTPUT CTRL pin is tied to  $V_{REF}$ , the TL594 is operating in normal push-pull operation (see [Table 1](#)).

**Table 1. Function Table**

INPUT	OUTPUT FUNCTION
OUTPUT CTRL	
$V_I = 0$	Single-ended or parallel output
$V_I = V_{ref}$	Normal push-pull operation

## 9 Application and Implementation

### NOTE

Information in the following applications sections is not part of the TI component specification, and TI does not warrant its accuracy or completeness. TI's customers are responsible for determining suitability of components for their purposes. Customers should validate and test their design implementation to confirm system functionality.

### 9.1 Application Information

The TL594 device contains an adjustable oscillator, a dead-time control comparator, a pulse-steering flip flop, two error amplifiers, and a 5-V regulator. The TL594 device can be used for a wide variety of switching converter applications over a frequency range of 1 Hz to 300 kHz, where the oscillation frequency is set by the RT and CT values. For additional information regarding designing switching voltage regulators with the TL594, see [Designing Switching Voltage Regulators With the TL494](#).

### 9.2 Typical Application

This design example uses the TL594 to create a 5-V, 10-A power supply. This application is from [Designing Switching Voltage Regulators With the TL494](#).

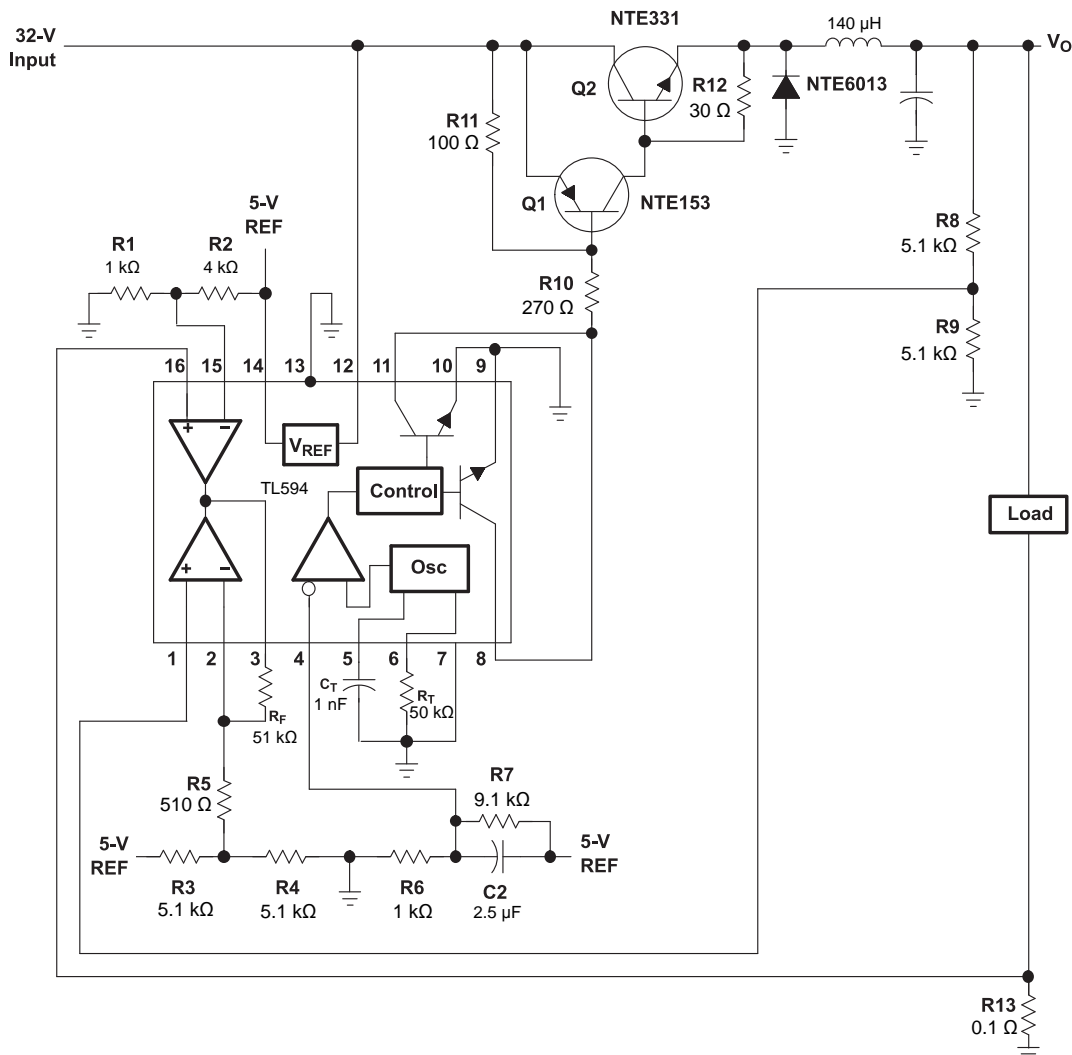

Copyright © 2016, Texas Instruments Incorporated

Figure 7. 32-V to 5-V, 10-A Power Supply Application

## Typical Application (continued)

### 9.2.1 Design Requirements

- $V_I = 32\text{ V}$
- $V_O = 5\text{ V}$
- $I_O = 10\text{ A}$
- $f_{OSC} = 20\text{-kHz}$  switching frequency
- $V_R = 20\text{-mV}$  peak-to-peak ( $V_{RIPPLE}$ )
- $\Delta I_L = 1.5\text{-A}$  inductor current change

### 9.2.2 Detailed Design Procedure

#### 9.2.2.1 Input Power Source

The 32-V dc power source for this supply uses a 120-V input, 24-V output transformer rated at 75 VA. The 24-V secondary winding feeds a full-wave bridge rectifier, followed by a current-limiting resistor ( $0.3\ \Omega$ ) and two filter capacitors (see Figure 8).

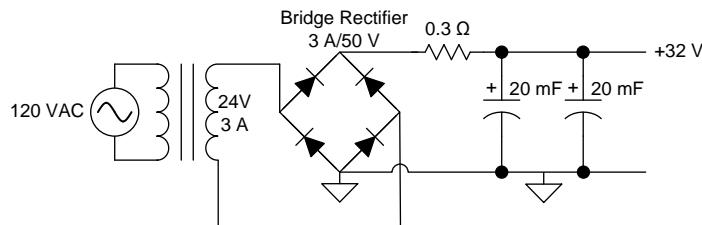

Figure 8. Input Power Source

The output voltage and current are determined by Equation 6 and Equation 7.

$$V_{RECTIFIER} = V_{SECONDARY} \times \sqrt{2} = 24\text{ V} \times \sqrt{2} = 34\text{ V} \tag{6}$$

$$I_{RECTIFIER(AVG)} \approx \frac{V_O}{V_I} \times I_O \approx \frac{5\text{ V}}{32\text{ V}} \times 10\text{ A} = 1.6\text{ A} \tag{7}$$

The 3-A, 50-V full-wave bridge rectifier meets these calculated conditions. Figure 7 shows the switching and control sections.

#### 9.2.2.2 Control Circuits

##### 9.2.2.2.1 Oscillator

Connecting an external capacitor and resistor to pins 5 and 6 controls the TL594 oscillator frequency. The oscillator is set to operate at 20 kHz, using the component values calculated by Equation 8 and Equation 9.

$$f_{OSC} = \frac{1}{R_T \times C_T} \tag{8}$$

Choose  $C_T = 0.001\ \mu\text{F}$  and calculate  $R_T$  with Equation 9.

$$R_T = \frac{1}{f_{OSC} \times C_T} = \frac{1}{(20 \times 10^3) \times (0.001 \times 10^{-6})} = 50\text{ k}\Omega \tag{9}$$

##### 9.2.2.2.2 Error Amplifier

The error amplifier compares a sample of the 5-V output to the reference and adjusts the PWM to maintain a constant output current (see Figure 9).

## Typical Application (continued)

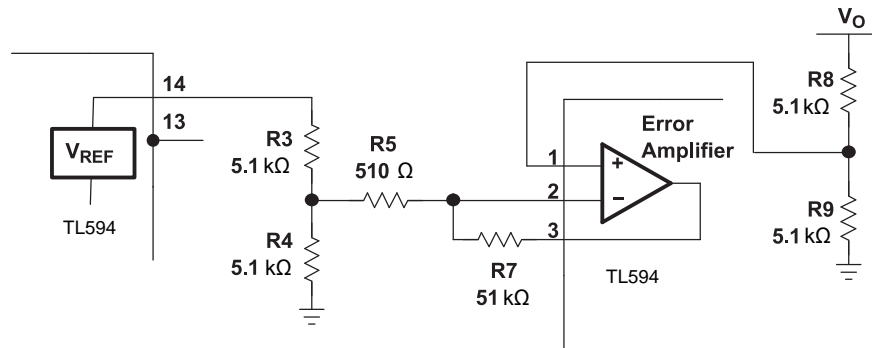

Figure 9. Error-Amplifier Section

The TL594 internal 5-V reference is divided to 2.5 V by R3 and R4. The output-voltage error signal also is divided to 2.5 V by R8 and R9. If the output must be regulated to exactly 5 V, a 10-kΩ potentiometer can be used in place of R8 to provide an adjustment.

To increase the stability of the error-amplifier circuit, the output of the error amplifier is fed back to the inverting input through R<sub>T</sub>, reducing the gain to 101.

### 9.2.2.2.3 Current-Limiting Amplifier

The power supply was designed for a 10-A load current and an I<sub>L</sub> swing of 1.5 A; therefore, the short-circuit current is calculated as Equation 10.

$$I_{SC} = I_o + \frac{I_L}{2} = 10.75 \text{ A} \quad (10)$$

Figure 10 shows the current-limiting circuit.

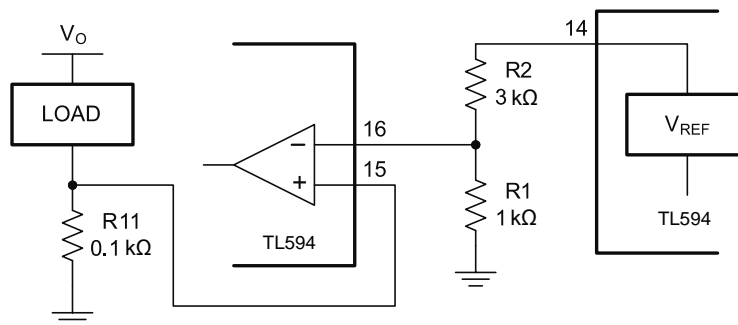

Figure 10. Current-Limiting Circuit

Resistors R1 and R2 set the reference of about 1 V on the inverting input of the current-limiting amplifier. Resistor R13, in series with the load, applies 1 V to the noninverting terminal of the current-limiting amplifier when the load current reaches 10 A. The output-pulse width is reduced accordingly. The value of R13 is calculated as Equation 11.

$$R13 = \frac{1 \text{ V}}{10 \text{ A}} = 0.1 \Omega \quad (11)$$

### 9.2.2.2.4 Soft Start

To reduce stress on the switching transistors at start-up, the start-up surge that occurs as the output filter capacitor charges must be reduced. The availability of the dead-time control makes implementation of a soft-start circuit relatively simple (see Figure 11).

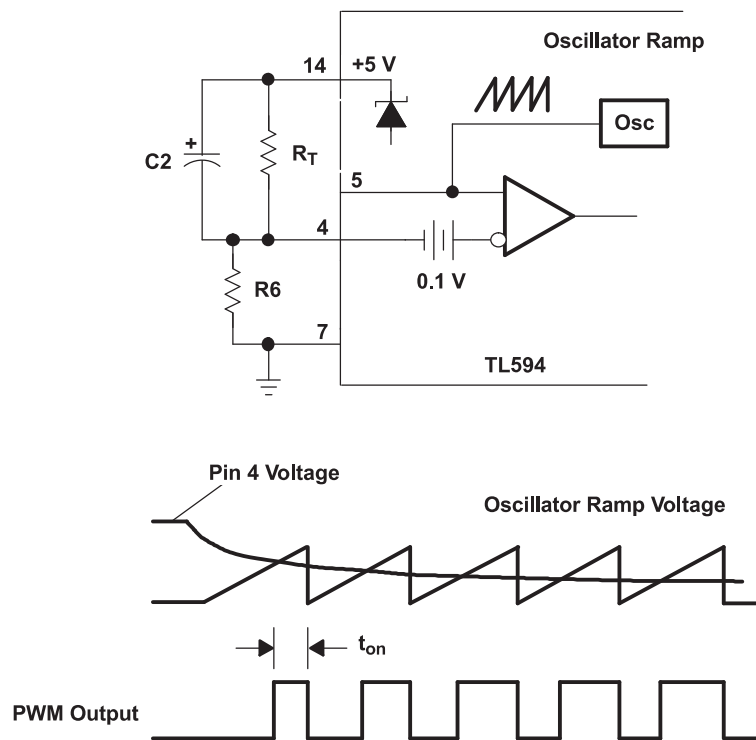
**Typical Application (continued)**

**Figure 11. Soft-Start Circuit**

The soft-start circuit allows the pulse width at the output to increase slowly (see [Figure 11](#)) by applying a negative slope waveform to the dead-time control input (pin 4).

Initially, capacitor C2 forces the dead-time control input to follow the 5-V regulator, which disables the outputs (100% dead time). As the capacitor charges through R6, the output pulse width slowly increases until the control loop takes command. With a resistor ratio of 1:10 for R6 and R7, the voltage at pin 4 after start-up is  $0.1 \times 5 \text{ V}$ , or 0.5 V.

The soft-start time generally is in the range of 25 to 100 clock cycles. If 50 clock cycles at a 20-kHz switching rate is selected, the soft-start time is calculated as [Equation 12](#).

$$t = \frac{1}{f} = \frac{1}{20\text{kHz}} = 50\mu\text{s per clock cycle} \quad (12)$$

The value of the capacitor then is determined with [Equation 13](#).

$$C2 = \frac{\text{soft-start time}}{R6} = \frac{50\mu\text{s} \times 50\text{cycles}}{1\text{k}\Omega} = 2.5\mu\text{F} \quad (13)$$

This helps eliminate any false signals that might be created by the control circuit as power is applied.

**9.2.2.2.5 Setting the Dead Time**

The primary function of the dead-time control is to control the minimum off time of the output of the TL594 device. The dead-time control input provides control from 5% to 100% dead time. The TL594 device can be tailored to the specific power transistor switches that are used, to ensure that the output transistors never experience a common on-time. [Figure 12](#) shows the bias circuit for the basic function.

## Typical Application (continued)

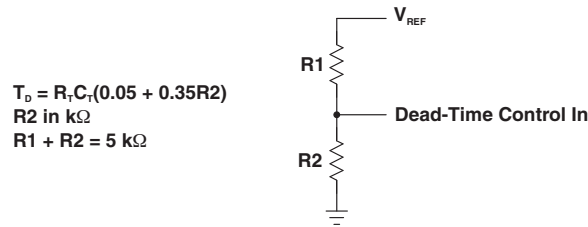

Figure 12. Setting Dead Time

### 9.2.2.3 Inductor Calculations

Figure 13 shows the switching circuit used.

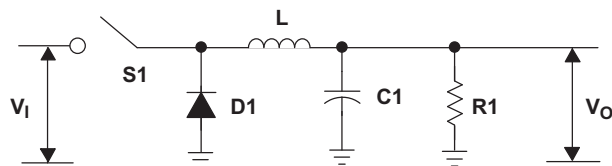

Figure 13. Switching Circuit

The size of the inductor (L) required is:

$$\begin{aligned} d &= \text{duty cycle} = V_O/V_I = 5\text{ V}/32\text{ V} = 0.156 \\ f &= 20\text{ kHz (design objective)} \\ t_{\text{on}} &= \text{time on (S1 closed)} = (1/f) \times d = 7.8\ \mu\text{s} \\ t_{\text{off}} &= \text{time off (S1 open)} = (1/f) - t_{\text{on}} = 42.2\ \mu\text{s} \\ L &\neq (V_I - V_O) \times t_{\text{on}}/\Delta I_L \\ &\neq [(32\text{ V} - 5\text{ V}) \times 7.8\ \mu\text{s}]/1.5\text{ A} \\ &\neq 140.4\ \mu\text{H} \end{aligned}$$

### 9.2.2.4 Output Capacitance Calculations

Once the filter inductor has been calculated, the value of the output filter capacitor is calculated to meet the output ripple requirements. An electrolytic capacitor can be modeled as a series connection of an inductance, a resistance, and a capacitance. To provide good filtering, the ripple frequency must be far below the frequencies at which the series inductance becomes important. So, the two components of interest are the capacitance and the effective series resistance (ESR). The maximum ESR is calculated with Equation 14 according to the relation between the specified peak-to-peak ripple voltage and the peak-to-peak ripple current.

$$\text{ESR(max)} = \frac{\Delta V_{O(\text{ripple})}}{\Delta I_L} = \frac{V}{1.5\text{ A}} \approx 0.067\ \Omega \quad (14)$$

The minimum capacitance of C3 necessary to maintain the  $V_O$  ripple voltage at less than the 100-mV design objective is calculated according to Equation 15.

$$C3 = \frac{\Delta I_L}{8f \Delta V_O} = \frac{1.5\text{ A}}{8 \times 20 \times 10^3 \times 0.1\text{ V}} = 94\ \mu\text{F} \quad (15)$$

A 220-mF, 60-V capacitor is selected because it has a maximum ESR of 0.074 Ω and a maximum ripple current of 2.8 A.

### 9.2.2.5 Transistor Power-Switch Calculations

The transistor power switch was constructed with an NTE153 pnp drive transistor and an NTE331 npn output transistor. These two power devices were connected in a pnp hybrid Darlington circuit configuration (see Figure 14).

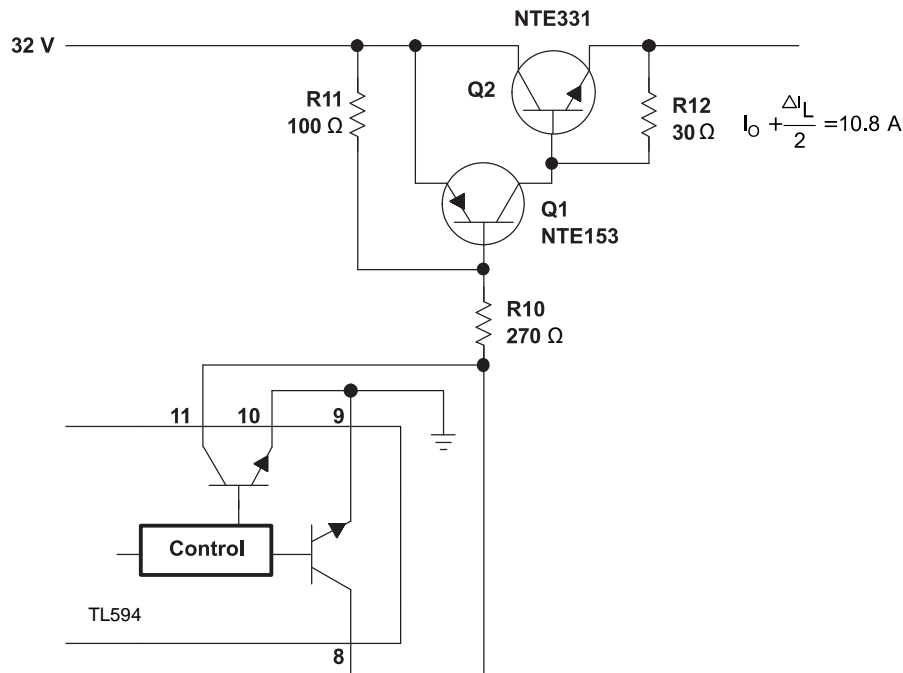

**Figure 14. Power-Switch Section**

The hybrid Darlington circuit must be saturated at a maximum output current of  $I_o + \Delta I_L/2$  or 10.8 A. The Darlington  $h_{FE}$  at 10.8 A must be high enough not to exceed the 250-mA maximum output collector current of the TL594. Based on published NTE153 and NTE331 specifications, the required power-switch minimum drive was calculated by Equation 16 through Equation 18 to be 144 mA.

$$h_{FE}(Q1) \text{ at } I_C \text{ of } 3A = 15 \quad (16)$$

$$h_{FE}(Q2) \text{ at } I_C \text{ of } 10.0A = 5 \quad (17)$$

$$i_B \geq \frac{I_o + \frac{I_L}{2}}{h_{FE}(Q2) \times h_{FE}(Q1)} \geq 144 \text{ mA} \quad (18)$$

The value of R10 was calculated by Equation 19.

$$R10 \leq \frac{V_I - [V_{BE}(Q1) + V_{CE}(TL494)]}{i_B} = \frac{32 - (1.5 + 0.7)}{0.144} \quad (19)$$

$$R10 \leq 207 \Omega$$

Based on these calculations, the nearest standard resistor value of 220  $\Omega$  was selected for R10. Resistors R11 and R12 permit the discharge of carriers in switching transistors when they are turned off.

The power supply described demonstrates the flexibility of the TL594 PWM control circuit. This power-supply design demonstrates many of the power-supply control methods provided by the TL594, as well as the versatility of the control circuit.

### 9.2.3 Application Curve

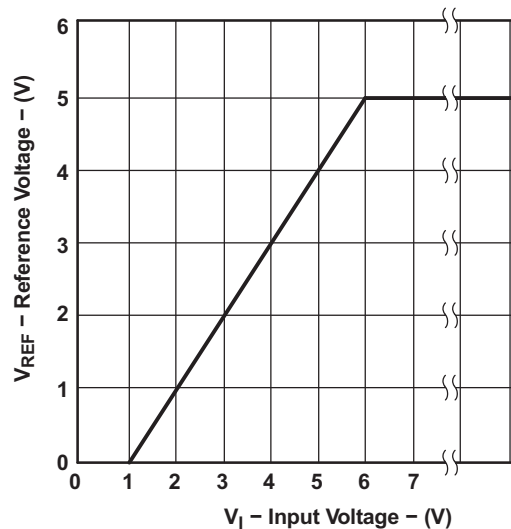

Figure 15. Reference Voltage vs Input Voltage

## 10 Power Supply Recommendations

The TL594 is designed to operate from an input voltage supply range between 7 V and 40 V. This input supply must be well regulated. If the input supply is placed more than a few inches from the device, additional bulk capacitance may be required in addition to the ceramic bypass capacitors. A tantalum capacitor with a value of 47  $\mu$ F is a typical choice; however this may vary depending upon the output power being delivered.

## 11 Layout

### 11.1 Layout Guidelines

Always try to use a low EMI inductor with a ferrite type closed core. Some examples would be toroid and encased E core inductors. Open core can be used if they have low EMI characteristics and are placed a bit more away from the low power traces and components. Make the poles perpendicular to the PCB as well if using an open core. Stick cores usually emit the most unwanted noise.

#### 11.1.1 Feedback Traces

Try to run the feedback trace as far from the inductor and noisy power traces as possible. The feedback trace must be as direct as possible and wider to decrease impedance. These two sometimes involve a trade-off, but keeping it away from inductor EMI and other noise sources is the more critical of the two. Run the feedback trace on the side of the PCB opposite of the inductor, ideally with a ground plane separating the two.

#### 11.1.2 Input or Output Capacitors

When using a low value ceramic input filter capacitor, it must be placed as close to the VCC pin of the IC as possible. This eliminates as much trace inductance effects as possible and give the internal IC rail a cleaner voltage supply. Some designs require the use of a feed-forward capacitor connected from the output to the feedback pin as well, usually for stability reasons. In this case it must also be positioned as close to the IC as possible. Using surface mount capacitors also reduces lead length and reduces the chance of noise coupling into the effective antenna created by through-hole components.

#### 11.1.3 Compensation Components

External compensation components for stability must also be placed close to the IC. Surface mount components are recommended here as well for the same reasons discussed for the filter capacitors. These must not be placed very close to the inductor either.

## Layout Guidelines (continued)

### 11.1.4 Traces and Ground Planes

Make all of the power (high current) traces as short and direct as possible, while trying to maximize trace width for the appropriate current carrying capability. It is good practice on a standard PCB board to make the traces an absolute minimum of 15 mils (0.381 mm) per Ampere. The inductor, output capacitors, and output diode must be as close to each other possible. This helps reduce the EMI radiated by the power traces due to the high switching currents through them. This also reduces lead inductance and resistance as well, which in turn reduces noise spikes, ringing, and resistive losses that produce voltage errors.

The grounds of the IC, input capacitors, output capacitors, and output diode (if applicable) must be connected close together directly to a ground plane. It would also be a good idea to have a ground plane on both sides of the PCB. This reduces noise as well by reducing ground loop errors as well as by absorbing more of the EMI radiated by the inductor. For multi-layer boards with more than two layers, a ground plane can be used to separate the power plane (where the power traces and components are) and the signal plane (where the feedback and compensation and components are) for improved performance.

On multi-layer boards the use of vias are required to connect traces and different planes. It is good practice to use one standard via per 200 mA of current if the trace requires conduct to a significant amount of current from one plane to the other. Arrange the components so that the switching current loops curl in the same direction. Due to the way switching regulators operate, there are two power states. One state when the switch is on and one when the switch is off. During each state there is a current loop made by the power components that are currently conducting. Place the power components so that during each of the two states the current loop is conducting in the same direction. This prevents magnetic field reversal caused by the traces between the two half-cycles and reduces radiated EMI.

### 11.2 Layout Example

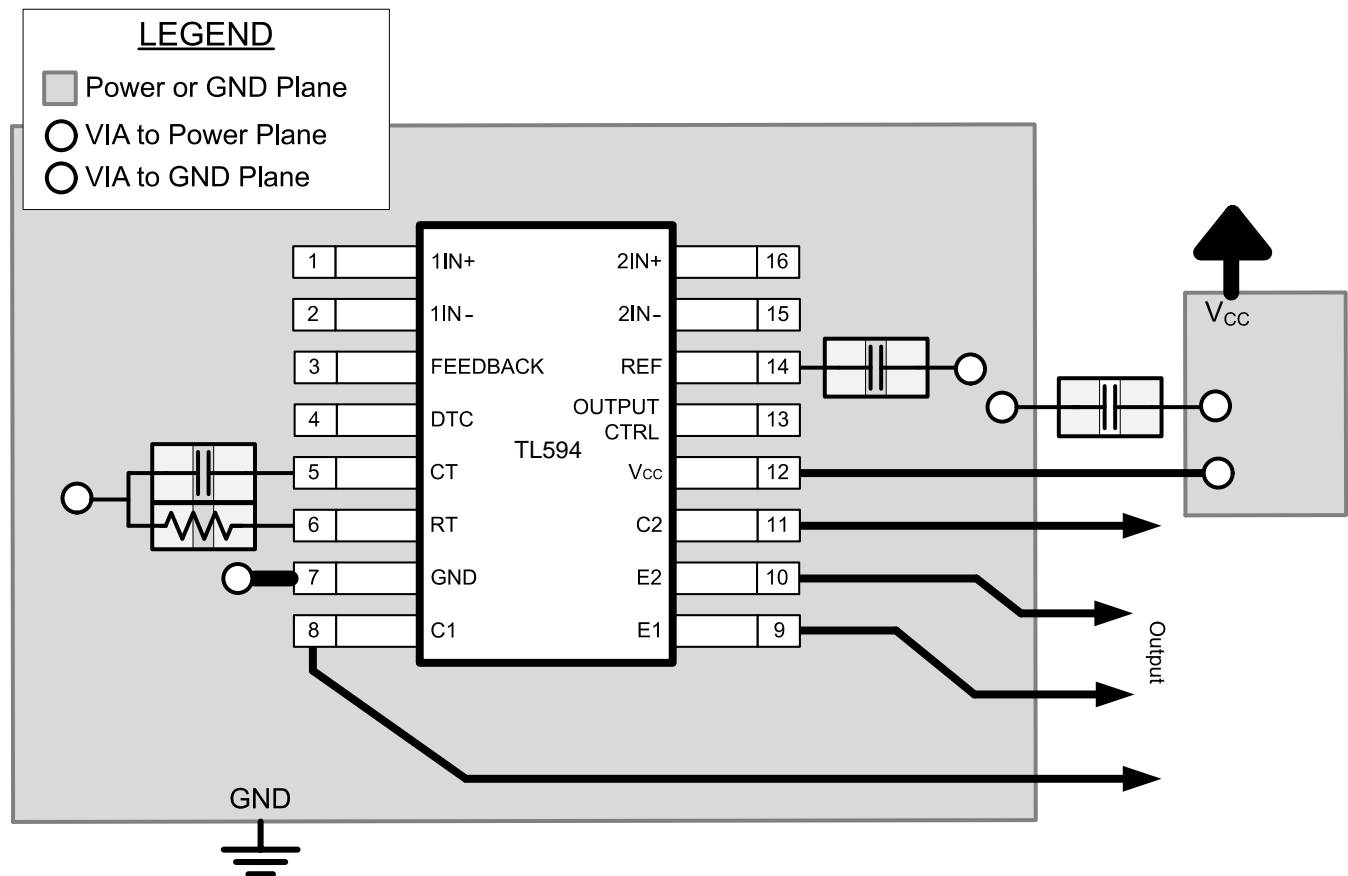

Copyright © 2016, Texas Instruments Incorporated

**Figure 16. TL594 Layout Example**

## 12 Device and Documentation Support

### 12.1 Documentation Support

#### 12.1.1 Related Documentation

For related documentation see the following:

[Designing Switching Voltage Regulators With the TL494](#) (SLVA001)

### 12.2 Receiving Notification of Documentation Updates

To receive notification of documentation updates, navigate to the device product folder on ti.com. In the upper right corner, click on *Alert me* to register and receive a weekly digest of any product information that has changed. For change details, review the revision history included in any revised document.

### 12.3 Community Resources

The following links connect to TI community resources. Linked contents are provided "AS IS" by the respective contributors. They do not constitute TI specifications and do not necessarily reflect TI's views; see TI's [Terms of Use](#).

**TI E2E™ Online Community** *TI's Engineer-to-Engineer (E2E) Community*. Created to foster collaboration among engineers. At e2e.ti.com, you can ask questions, share knowledge, explore ideas and help solve problems with fellow engineers.

**Design Support** *TI's Design Support* Quickly find helpful E2E forums along with design support tools and contact information for technical support.

### 12.4 Trademarks

E2E is a trademark of Texas Instruments.  
All other trademarks are the property of their respective owners.

### 12.5 Electrostatic Discharge Caution



These devices have limited built-in ESD protection. The leads should be shorted together or the device placed in conductive foam during storage or handling to prevent electrostatic damage to the MOS gates.

### 12.6 Glossary

[SLYZ022](#) — *TI Glossary*.

This glossary lists and explains terms, acronyms, and definitions.

## 13 Mechanical, Packaging, and Orderable Information

The following pages include mechanical, packaging, and orderable information. This information is the most current data available for the designated devices. This data is subject to change without notice and revision of this document. For browser-based versions of this data sheet, refer to the left-hand navigation.

**PACKAGING INFORMATION**

Orderable Device	Status (1)	Package Type	Package Drawing	Pins	Package Qty	Eco Plan (2)	Lead finish/ Ball material (6)	MSL Peak Temp (3)	Op Temp (°C)	Device Marking (4/5)	Samples
TL594CDR	ACTIVE	SOIC	D	16	2500	RoHS & Green	NIPDAU   SN	Level-1-260C-UNLIM	0 to 70	TL594C	<a href="#">Samples</a>
TL594CN	ACTIVE	PDIP	N	16	25	RoHS & Green	NIPDAU	N / A for Pkg Type	0 to 70	TL594CN	<a href="#">Samples</a>
TL594CNE4	ACTIVE	PDIP	N	16	25	RoHS & Green	NIPDAU	N / A for Pkg Type	0 to 70	TL594CN	<a href="#">Samples</a>
TL594CNSR	ACTIVE	SO	NS	16	2000	RoHS & Green	NIPDAU	Level-1-260C-UNLIM	0 to 70	TL594	<a href="#">Samples</a>
TL594CPWR	ACTIVE	TSSOP	PW	16	2000	RoHS & Green	NIPDAU	Level-1-260C-UNLIM	0 to 70	T594	<a href="#">Samples</a>
TL594CPWRG4	ACTIVE	TSSOP	PW	16	2000	RoHS & Green	NIPDAU	Level-1-260C-UNLIM	0 to 70	T594	<a href="#">Samples</a>
TL594IDR	ACTIVE	SOIC	D	16	2500	RoHS & Green	NIPDAU	Level-1-260C-UNLIM	-40 to 85	TL594I	<a href="#">Samples</a>
TL594IDRG4	ACTIVE	SOIC	D	16	2500	RoHS & Green	NIPDAU	Level-1-260C-UNLIM	-40 to 85	TL594I	<a href="#">Samples</a>
TL594IN	ACTIVE	PDIP	N	16	25	RoHS & Green	NIPDAU	N / A for Pkg Type	-40 to 85	TL594IN	<a href="#">Samples</a>
TL594INSR	ACTIVE	SO	NS	16	2000	RoHS & Green	NIPDAU	Level-1-260C-UNLIM	-40 to 85	TL594I	<a href="#">Samples</a>
TL594INSRG4	ACTIVE	SO	NS	16	2000	RoHS & Green	NIPDAU	Level-1-260C-UNLIM	-40 to 85	TL594I	<a href="#">Samples</a>
TL594IPWR	ACTIVE	TSSOP	PW	16	2000	RoHS & Green	NIPDAU	Level-1-260C-UNLIM	-40 to 85	Z594	<a href="#">Samples</a>
TL594IPWRG4	ACTIVE	TSSOP	PW	16	2000	RoHS & Green	NIPDAU	Level-1-260C-UNLIM	-40 to 85	Z594	<a href="#">Samples</a>

(1) The marketing status values are defined as follows:

**ACTIVE:** Product device recommended for new designs.

**LIFEBUY:** TI has announced that the device will be discontinued, and a lifetime-buy period is in effect.

**NRND:** Not recommended for new designs. Device is in production to support existing customers, but TI does not recommend using this part in a new design.

**PREVIEW:** Device has been announced but is not in production. Samples may or may not be available.

**OBSELETE:** TI has discontinued the production of the device.

(2) **RoHS:** TI defines "RoHS" to mean semiconductor products that are compliant with the current EU RoHS requirements for all 10 RoHS substances, including the requirement that RoHS substance do not exceed 0.1% by weight in homogeneous materials. Where designed to be soldered at high temperatures, "RoHS" products are suitable for use in specified lead-free processes. TI may reference these types of products as "Pb-Free".

**RoHS Exempt:** TI defines "RoHS Exempt" to mean products that contain lead but are compliant with EU RoHS pursuant to a specific EU RoHS exemption.

**Green:** TI defines "Green" to mean the content of Chlorine (Cl) and Bromine (Br) based flame retardants meet JS709B low halogen requirements of <=1000ppm threshold. Antimony trioxide based flame retardants must also meet the <=1000ppm threshold requirement.

- (3) MSL, Peak Temp. - The Moisture Sensitivity Level rating according to the JEDEC industry standard classifications, and peak solder temperature.
- (4) There may be additional marking, which relates to the logo, the lot trace code information, or the environmental category on the device.
- (5) Multiple Device Markings will be inside parentheses. Only one Device Marking contained in parentheses and separated by a "~" will appear on a device. If a line is indented then it is a continuation of the previous line and the two combined represent the entire Device Marking for that device.
- (6) Lead finish/Ball material - Orderable Devices may have multiple material finish options. Finish options are separated by a vertical ruled line. Lead finish/Ball material values may wrap to two lines if the finish value exceeds the maximum column width.

**Important Information and Disclaimer:**The information provided on this page represents TI's knowledge and belief as of the date that it is provided. TI bases its knowledge and belief on information provided by third parties, and makes no representation or warranty as to the accuracy of such information. Efforts are underway to better integrate information from third parties. TI has taken and continues to take reasonable steps to provide representative and accurate information but may not have conducted destructive testing or chemical analysis on incoming materials and chemicals. TI and TI suppliers consider certain information to be proprietary, and thus CAS numbers and other limited information may not be available for release.

In no event shall TI's liability arising out of such information exceed the total purchase price of the TI part(s) at issue in this document sold by TI to Customer on an annual basis.

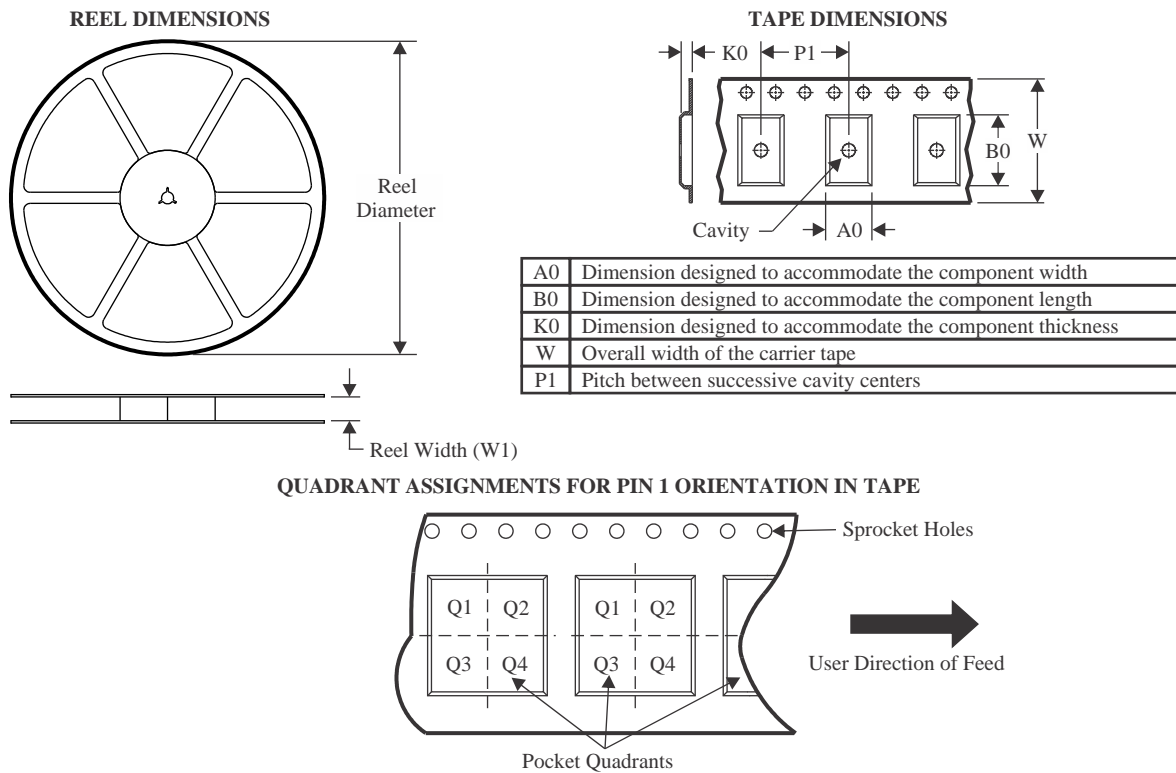
**TAPE AND REEL INFORMATION**

\*All dimensions are nominal

Device	Package Type	Package Drawing	Pins	SPQ	Reel Diameter (mm)	Reel Width W1 (mm)	A0 (mm)	B0 (mm)	K0 (mm)	P1 (mm)	W (mm)	Pin1 Quadrant
TL594CDR	SOIC	D	16	2500	330.0	16.4	6.5	10.3	2.1	8.0	16.0	Q1
TL594CNSR	SO	NS	16	2000	330.0	16.4	8.2	10.5	2.5	12.0	16.0	Q1
TL594CPWR	TSSOP	PW	16	2000	330.0	12.4	6.9	5.6	1.6	8.0	12.0	Q1
TL594IDR	SOIC	D	16	2500	330.0	16.4	6.5	10.3	2.1	8.0	16.0	Q1
TL594INSR	SO	NS	16	2000	330.0	16.4	8.2	10.5	2.5	12.0	16.0	Q1
TL594IPWR	TSSOP	PW	16	2000	330.0	12.4	6.9	5.6	1.6	8.0	12.0	Q1

**TAPE AND REEL BOX DIMENSIONS**

\*All dimensions are nominal

Device	Package Type	Package Drawing	Pins	SPQ	Length (mm)	Width (mm)	Height (mm)
TL594CDR	SOIC	D	16	2500	340.5	336.1	32.0
TL594CNSR	SO	NS	16	2000	367.0	367.0	38.0
TL594CPWR	TSSOP	PW	16	2000	356.0	356.0	35.0
TL594IDR	SOIC	D	16	2500	340.5	336.1	32.0
TL594INSR	SO	NS	16	2000	367.0	367.0	38.0
TL594IPWR	TSSOP	PW	16	2000	356.0	356.0	35.0

**TUBE**

\*All dimensions are nominal

Device	Package Name	Package Type	Pins	SPQ	L (mm)	W (mm)	T (μm)	B (mm)
TL594CN	N	PDIP	16	25	506	13.97	11230	4.32
TL594CN	N	PDIP	16	25	506	13.97	11230	4.32
TL594CNE4	N	PDIP	16	25	506	13.97	11230	4.32
TL594CNE4	N	PDIP	16	25	506	13.97	11230	4.32
TL594IN	N	PDIP	16	25	506	13.97	11230	4.32

D (R-PDSO-G16)

PLASTIC SMALL OUTLINE



- NOTES:
- A. All linear dimensions are in inches (millimeters).
  - B. This drawing is subject to change without notice.
  - C. Body length does not include mold flash, protrusions, or gate burrs. Mold flash, protrusions, or gate burrs shall not exceed 0.006 (0,15) each side.
  - D. Body width does not include interlead flash. Interlead flash shall not exceed 0.017 (0,43) each side.
  - E. Reference JEDEC MS-012 variation AC.

D (R-PDSO-G16)

PLASTIC SMALL OUTLINE



- NOTES:
- All linear dimensions are in millimeters.
  - This drawing is subject to change without notice.
  - Publication IPC-7351 is recommended for alternate designs.
  - Laser cutting apertures with trapezoidal walls and also rounding corners will offer better paste release. Customers should contact their board assembly site for stencil design recommendations. Refer to IPC-7525 for other stencil recommendations.
  - Customers should contact their board fabrication site for solder mask tolerances between and around signal pads.



4220204/A 02/2017

NOTES:

1. All linear dimensions are in millimeters. Any dimensions in parenthesis are for reference only. Dimensioning and tolerancing per ASME Y14.5M.
2. This drawing is subject to change without notice.
3. This dimension does not include mold flash, protrusions, or gate burrs. Mold flash, protrusions, or gate burrs shall not exceed 0.15 mm per side.
4. This dimension does not include interlead flash. Interlead flash shall not exceed 0.25 mm per side.
5. Reference JEDEC registration MO-153.

# EXAMPLE BOARD LAYOUT

PW0016A

TSSOP - 1.2 mm max height

SMALL OUTLINE PACKAGE



LAND PATTERN EXAMPLE  
EXPOSED METAL SHOWN  
SCALE: 10X



4220204/A 02/2017

NOTES: (continued)

6. Publication IPC-7351 may have alternate designs.
7. Solder mask tolerances between and around signal pads can vary based on board fabrication site.

# EXAMPLE STENCIL DESIGN

PW0016A

TSSOP - 1.2 mm max height

SMALL OUTLINE PACKAGE



SOLDER PASTE EXAMPLE  
BASED ON 0.125 mm THICK STENCIL  
SCALE: 10X

4220204/A 02/2017

NOTES: (continued)

8. Laser cutting apertures with trapezoidal walls and rounded corners may offer better paste release. IPC-7525 may have alternate design recommendations.
9. Board assembly site may have different recommendations for stencil design.

# MECHANICAL DATA

NS (R-PDSO-G\*\*)

PLASTIC SMALL-OUTLINE PACKAGE

14-PINS SHOWN



- NOTES:
- A. All linear dimensions are in millimeters.
  - B. This drawing is subject to change without notice.
  - C. Body dimensions do not include mold flash or protrusion, not to exceed 0,15.

N (R-PDIP-T\*\*)

PLASTIC DUAL-IN-LINE PACKAGE

16 PINS SHOWN



4040049/E 12/2002

- NOTES:
- A. All linear dimensions are in inches (millimeters).
  - B. This drawing is subject to change without notice.
  - (C) Falls within JEDEC MS-001, except 18 and 20 pin minimum body length (Dim A).
  - (D) The 20 pin end lead shoulder width is a vendor option, either half or full width.



# PACKAGE OUTLINE

## NS0016A

### SOP - 2.00 mm max height

SOP

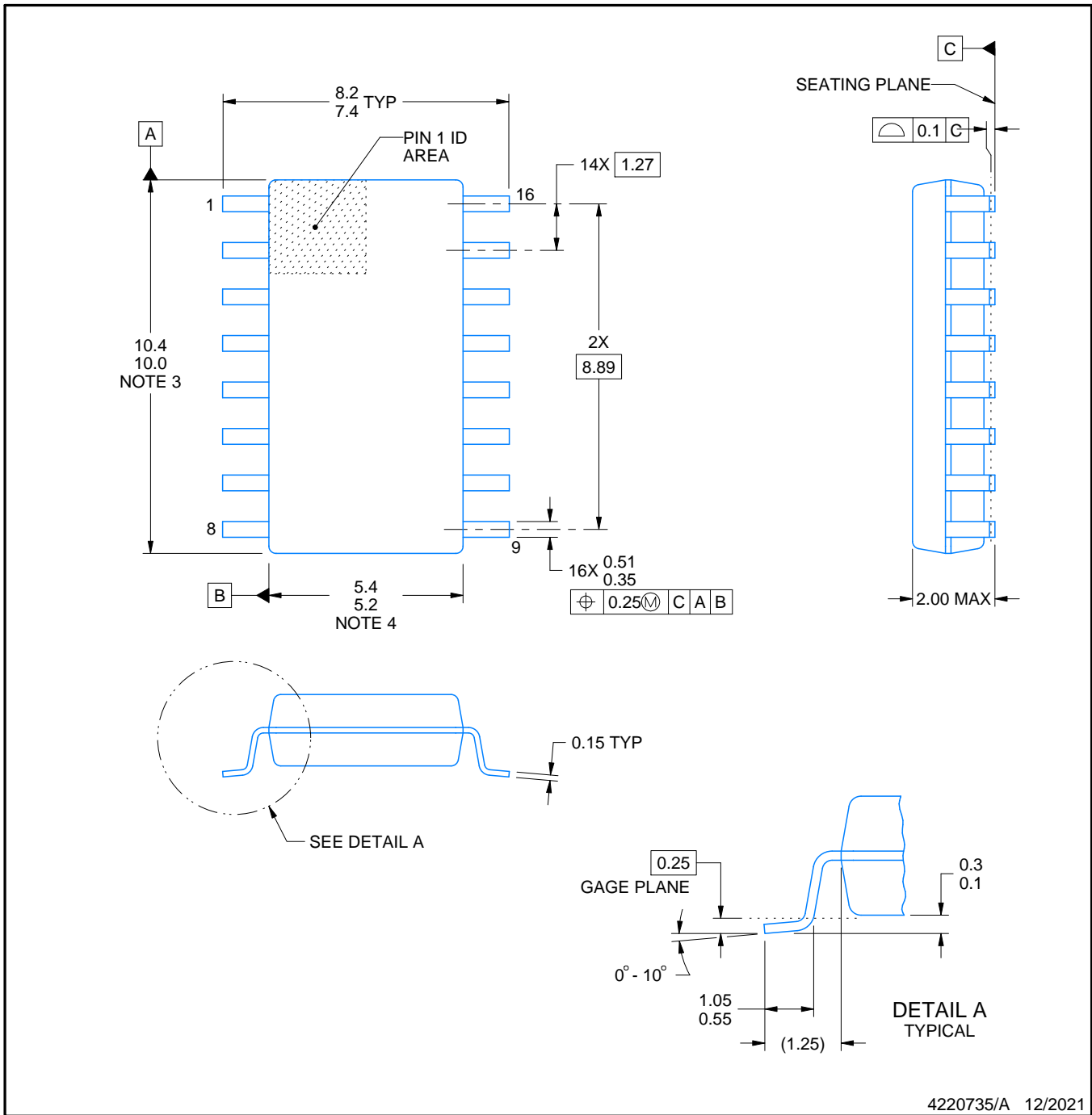

4220735/A 12/2021

#### NOTES:

1. All linear dimensions are in millimeters. Dimensions in parenthesis are for reference only. Dimensioning and tolerancing per ASME Y14.5M.
2. This drawing is subject to change without notice.
3. This dimension does not include mold flash, protrusions, or gate burrs. Mold flash, protrusions, or gate burrs shall not exceed 0.15 mm, per side.
4. This dimension does not include interlead flash. Interlead flash shall not exceed 0.25 mm, per side.

# EXAMPLE BOARD LAYOUT

NS0016A

SOP - 2.00 mm max height

SOP



SOLDER MASK DETAILS

4220735/A 12/2021

NOTES: (continued)

5. Publication IPC-7351 may have alternate designs.

6. Solder mask tolerances between and around signal pads can vary based on board fabrication site.

# EXAMPLE STENCIL DESIGN

NS0016A

SOP - 2.00 mm max height

SOP

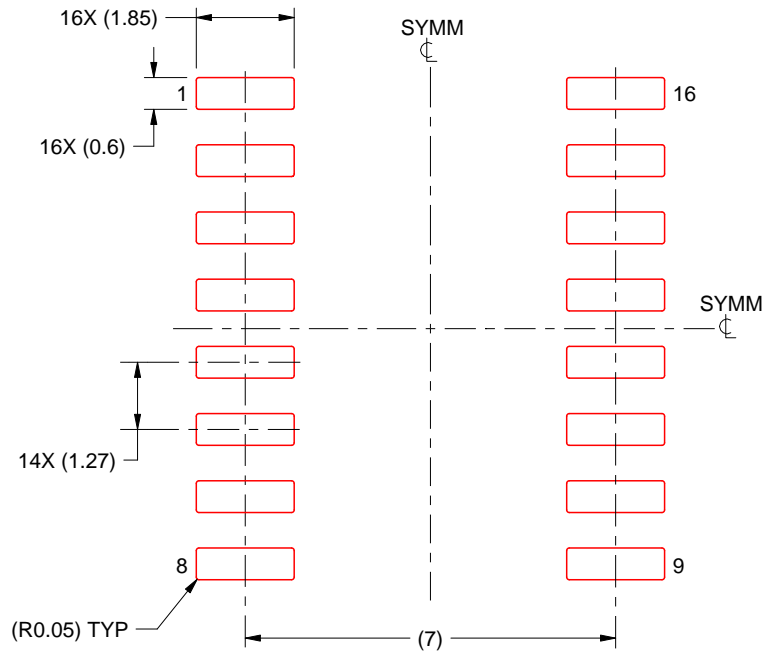

SOLDER PASTE EXAMPLE  
BASED ON 0.125 mm THICK STENCIL  
SCALE:7X

4220735/A 12/2021

NOTES: (continued)

7. Laser cutting apertures with trapezoidal walls and rounded corners may offer better paste release. IPC-7525 may have alternate design recommendations.
8. Board assembly site may have different recommendations for stencil design.

## IMPORTANT NOTICE AND DISCLAIMER

TI PROVIDES TECHNICAL AND RELIABILITY DATA (INCLUDING DATA SHEETS), DESIGN RESOURCES (INCLUDING REFERENCE DESIGNS), APPLICATION OR OTHER DESIGN ADVICE, WEB TOOLS, SAFETY INFORMATION, AND OTHER RESOURCES "AS IS" AND WITH ALL FAULTS, AND DISCLAIMS ALL WARRANTIES, EXPRESS AND IMPLIED, INCLUDING WITHOUT LIMITATION ANY IMPLIED WARRANTIES OF MERCHANTABILITY, FITNESS FOR A PARTICULAR PURPOSE OR NON-INFRINGEMENT OF THIRD PARTY INTELLECTUAL PROPERTY RIGHTS.

These resources are intended for skilled developers designing with TI products. You are solely responsible for (1) selecting the appropriate TI products for your application, (2) designing, validating and testing your application, and (3) ensuring your application meets applicable standards, and any other safety, security, regulatory or other requirements.

These resources are subject to change without notice. TI grants you permission to use these resources only for development of an application that uses the TI products described in the resource. Other reproduction and display of these resources is prohibited. No license is granted to any other TI intellectual property right or to any third party intellectual property right. TI disclaims responsibility for, and you will fully indemnify TI and its representatives against, any claims, damages, costs, losses, and liabilities arising out of your use of these resources.

TI's products are provided subject to [TI's Terms of Sale](#) or other applicable terms available either on [ti.com](https://www.ti.com) or provided in conjunction with such TI products. TI's provision of these resources does not expand or otherwise alter TI's applicable warranties or warranty disclaimers for TI products.

TI objects to and rejects any additional or different terms you may have proposed.

Mailing Address: Texas Instruments, Post Office Box 655303, Dallas, Texas 75265  
Copyright © 2024, Texas Instruments Incorporated

## Looking for pricing, stock, or lifecycle information?

Click below to explore more details on WIN SOURCE:

 [View TL594CPWR](#) on WIN SOURCE

 [Texas Instruments](#) Information

## Optimize Your Supply Chain with WIN SOURCE Solutions

-  Global Sourcing Solution
-  Obsolete Management
-  Cost Control Management
-  Shortage Management
-  Alternative Solution
-  Excess Inventory Management