



THE DATASHEET OF TLC1550IFNR



TLC1550I, TLC1550M, TLC1551I 10-BIT ANALOG-TO-DIGITAL CONVERTERS WITH PARALLEL OUTPUTS

SLAS043G – MAY 1991 – REVISED NOVEMBER 2003

- Power Dissipation . . . 40 mW Max
- Advanced LinEPIC™ Single-Poly Process Provides Close Capacitor Matching for Better Accuracy
- Fast Parallel Processing for DSP and μ P Interface
- Either External or Internal Clock Can Be Used
- Conversion Time . . . 6 μ s
- Total Unadjusted Error . . . ± 1 LSB Max
- CMOS Technology

description

The TLC1550x and TLC1551 are data acquisition analog-to-digital converters (ADCs) using a 10-bit, switched-capacitor, successive-approximation network. A high-speed, 3-state parallel port directly interfaces to a digital signal processor (DSP) or microprocessor (μ P) system data bus. D0 through D9 are the digital output terminals with D0 being the least significant bit (LSB). Separate power terminals for the analog and digital portions minimize noise pickup in the supply leads. Additionally, the digital power is divided into two parts to separate the lower current logic from the higher current bus drivers. An external clock can be applied to CLKIN to override the internal system clock if desired.

The TLC1550I and TLC1551I are characterized for operation from -40°C to 85°C . The TLC1550M is characterized over the full military range of -55°C to 125°C .

J† OR DW PACKAGE
(TOP VIEW)

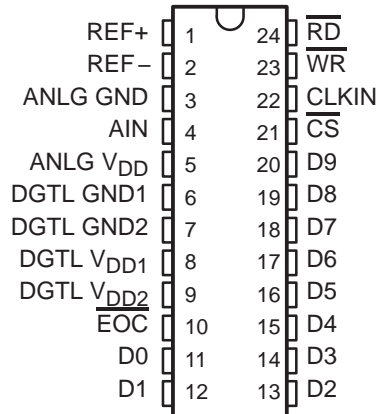

† Refer to the mechanical data for the JW package.

FK OR FN PACKAGE
(TOP VIEW)

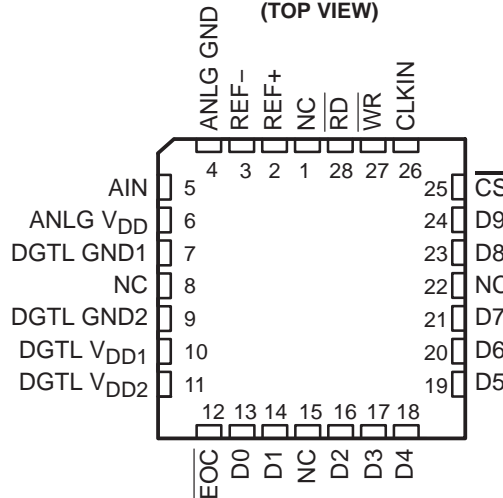

NC – No internal connection

AVAILABLE OPTIONS

T _A	PACKAGE			
	CERAMIC CHIP CARRIER (FK)	PLASTIC CHIP CARRIER (FN)	CERAMIC DIP (J)	SOIC (DW)
-40°C to 85°C	—	TLC1550IFN TLC1551IFN	—	TLC1550IDW TLC1551IDW
-55°C to 125°C	TLC1550MFK	—	TLC1550MJ	—



This device contains circuits to protect its inputs and outputs against damage due to high static voltages or electrostatic fields. These circuits have been qualified to protect this device against electrostatic discharges (ESD) of up to 2 kV according to MIL-STD-883C, Method 3015; however, it is advised that precautions be taken to avoid application of any voltage higher than maximum-rated voltages to these high-impedance circuits. During storage or handling, the device leads should be shorted together or the device should be placed in conductive foam. In a circuit, unused inputs should always be connected to an appropriated logic voltage level, preferably either V_{CC} or ground.



Please be aware that an important notice concerning availability, standard warranty, and use in critical applications of Texas Instruments semiconductor products and disclaimers thereto appears at the end of this data sheet.

Advanced LinEPIC is a trademark of Texas Instruments.

PRODUCTION DATA information is current as of publication date. Products conform to specifications per the terms of Texas Instruments standard warranty. Production processing does not necessarily include testing of all parameters.



POST OFFICE BOX 655303 • DALLAS, TEXAS 75265

Copyright © 2003, Texas Instruments Incorporated
On products compliant to MIL-PRF-38535, all parameters are tested unless otherwise noted. On all other products, production processing does not necessarily include testing of all parameters.

TLC1550I, TLC1550M, TLC1551I

10-BIT ANALOG-TO-DIGITAL CONVERTERS

WITH PARALLEL OUTPUTS

SLAS043G – MAY 1991 – REVISED NOVEMBER 2003

functional block diagram

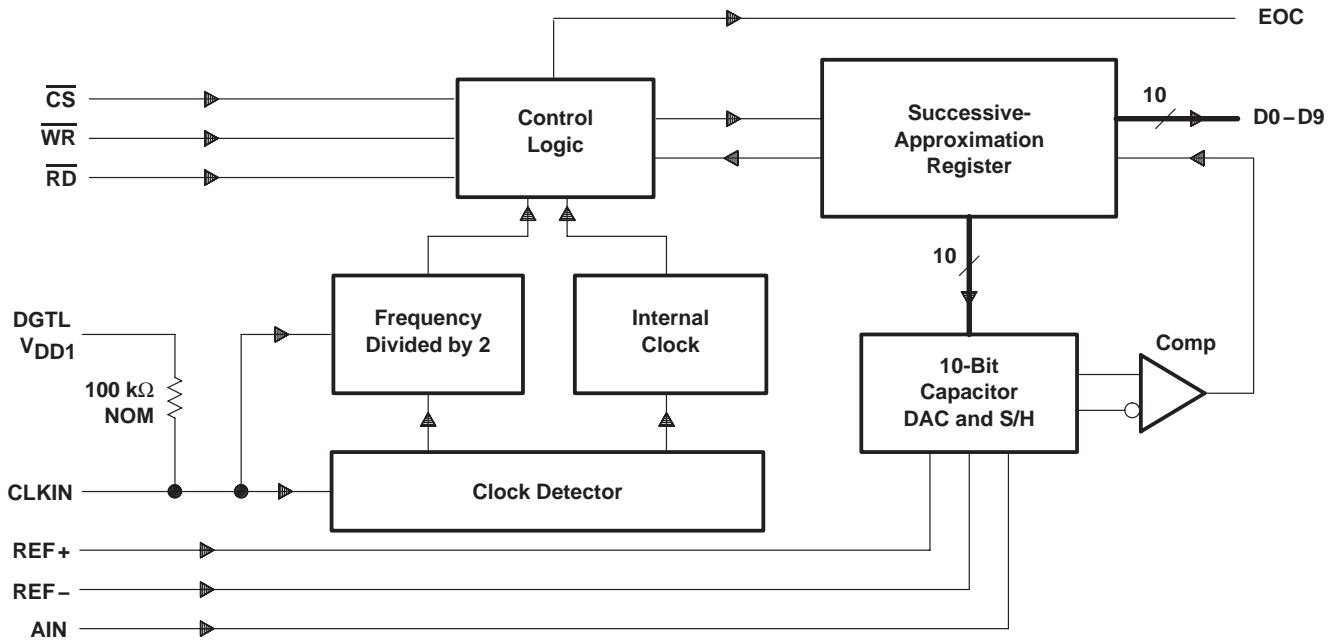

typical equivalent inputs

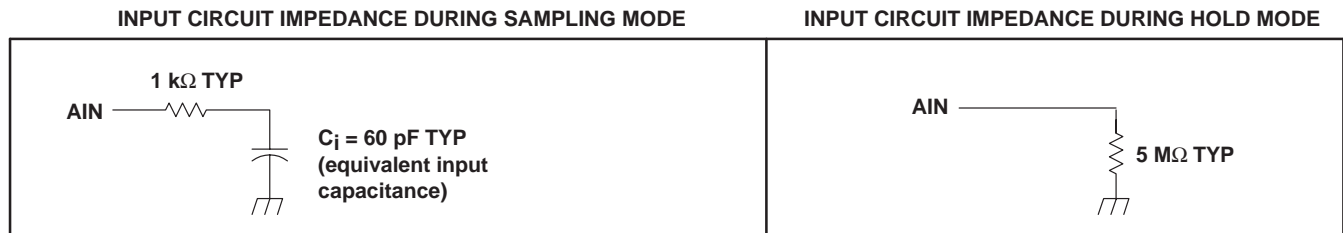

TLC1550I, TLC1550M, TLC1551I 10-BIT ANALOG-TO-DIGITAL CONVERTERS WITH PARALLEL OUTPUTS

SLAS043G – MAY 1991 – REVISED NOVEMBER 2003

Terminal Functions

TERMINAL			DESCRIPTION
NAME	NO.†	NO.‡	
ANLG GND	4	3	Analog ground. The reference point for the voltage applied on terminals ANLG V_{DD} , AIN, REF+, and REF-.
AIN	5	4	Analog voltage input. The voltage applied to AIN is converted to the equivalent digital output.
ANLG V_{DD}	6	5	Analog positive power supply voltage. The voltage applied to this terminal is designated V_{DD3} .
CLKIN	26	22	Clock input. CLKIN is used for external clocking instead of using the internal system clock. It usually takes a few microseconds before the internal clock is disabled. To use the internal clock, CLKIN should be tied high or left unconnected.
\overline{CS}	25	21	Chip-select. \overline{CS} must be low for \overline{RD} or \overline{WR} to be recognized by the A/D converter.
D0	13	11	Data bus output. D0 is bit 1 (LSB).
D1	14	12	Data bus output. D1 is bit 2.
D2	16	13	Data bus output. D2 is bit 3.
D3	17	14	Data bus output. D3 is bit 4.
D4	18	15	Data bus output. D4 is bit 5.
D5	19	16	Data bus output. D5 is bit 6.
D6	20	17	Data bus output. D6 is bit 7.
D7	21	18	Data bus output. D7 is bit 8.
D8	23	19	Data bus output. D8 is bit 9.
D9	24	20	Data bus output. D9 is bit 10 (MSB).
DGTL GND1	7	6	Digital ground 1. The ground for power supply DGTL V_{DD1} and is the substrate connection
DGTL GND2	9	7	Digital ground 2. The ground for power supply DGTL V_{DD2}
DGTL V_{DD1}	10	8	Digital positive power-supply voltage 1. DGTL V_{DD1} supplies the logic. The voltage applied to DGTL V_{DD1} is designated V_{DD1} .
DGTL V_{DD2}	11	9	Digital positive power-supply voltage 2. DGTL V_{DD2} supplies only the higher-current output buffers. The voltage applied to DGTL V_{DD2} is designated V_{DD2} .
\overline{EOC}	12	10	End-of-conversion. \overline{EOC} goes low indicating that conversion is complete and the results have been transferred to the output latch. \overline{EOC} can be connected to the μP - or DSP-interrupt terminal or can be continuously polled.
\overline{RD}	28	24	Read input. When \overline{CS} is low and \overline{RD} is taken low, the data is placed on the data bus from the output latch. The output latch stores the conversion results at the most recent negative edge of \overline{EOC} . The falling edge of \overline{RD} resets \overline{EOC} to a high within the $t_d(\overline{EOC})$ specifications.
REF+	2	1	Positive voltage-reference input. Any analog input that is greater than or equal to the voltage on REF+ converts to 1111111111. Analog input voltages between REF+ and REF- convert to the appropriate result in a ratiometric manner.
REF-	3	2	Negative voltage reference input. Any analog input that is less than or equal to the voltage on REF- converts to 0000000000.
\overline{WR}	27	23	Write input. When \overline{CS} is low, conversion is started on the rising edge of \overline{WR} . On this rising edge, the ADC holds the analog input until conversion is completed. Before and after the conversion period, which is given by t_{conv} , the ADC remains in the sampling mode.

† Terminal numbers for FK and FN packages.

‡ Terminal numbers for J, DW, and NW packages.



TLC1550I, TLC1550M, TLC1551I

10-BIT ANALOG-TO-DIGITAL CONVERTERS

WITH PARALLEL OUTPUTS

SLAS043G – MAY 1991 – REVISED NOVEMBER 2003

absolute maximum ratings over operating free-air temperature range (unless otherwise noted)†

Supply voltage, V_{DD1} , V_{DD2} , and V_{DD3} (see Note 1)	6.5 V
Input voltage range, V_I (any input)	-0.3 V to $V_{DD} + 0.3$ V
Output voltage range, V_O	-0.3 V to $V_{DD} + 0.3$ V
Peak input current (any digital input)	± 10 mA
Peak total input current (all inputs)	± 30 mA
Operating free-air temperature range, T_A : TLC1550I, TLC1551I	-40°C to 85°C
TLC1550M	-55°C to 125°C
Storage temperature range, T_{stg}	-65°C to 150°C
Case temperature for 10 seconds: FK or FN package	260°C
Lead temperature 1,6 mm (1/16 inch) from the case for 10 seconds: J or NW package	260°C

† Stresses beyond those listed under “absolute maximum ratings” may cause permanent damage to the device. These are stress ratings only, and functional operation of the device at these or any other conditions beyond those indicated under “recommended operating conditions” is not implied. Exposure to absolute-maximum-rated conditions for extended periods may affect device reliability.

NOTE 1: V_{DD1} is the voltage measured at DGTL V_{DD1} with respect to DGND1. V_{DD2} is the voltage measured at DGTL V_{DD2} with respect to the DGND2. V_{DD3} is the voltage measured at ANLG V_{DD} with respect to AGND. For these specifications, all ground terminals are tied together (and represent 0 V). When V_{DD1} , V_{DD2} , and V_{DD3} are equal, they are referred to simply as V_{DD} .

recommended operating conditions

	MIN	NOM	MAX	UNIT
Supply voltage, V_{DD1} , V_{DD2} , V_{DD3}	4.75	5	5.5	V
Positive reference voltage, V_{REF+} (see Note 2)		V_{DD3}		V
Negative reference voltage, V_{REF-} (see Note 2)		0		V
Differential reference voltage, $V_{REF+} - V_{REF-}$ (see Note 2)			V_{DD3}	V
Analog input voltage range	0		V_{DD3}	V
High-level control input voltage, V_{IH}	2			V
Low-level control input voltage, V_{IL}			0.8	V
Input clock frequency, $f_{(CLKIN)}$	0.5		7.8	MHz
Setup time, \overline{CS} low before \overline{WR} or \overline{RD} goes low, $t_{su}(CS)$	0			ns
Hold time, \overline{CS} low after \overline{WR} or \overline{RD} goes high, $t_h(CS)$	0			ns
\overline{WR} or \overline{RD} pulse duration, $t_w(WR)$	50			ns
Input clock low pulse duration, $t_w(L-CLKIN)$	40% of period		80% of period	
Operating free-air temperature, T_A	TLC155xI	-40	85	°C
	TLC1550M	-55	125	

NOTE 2: Analog input voltages greater than that applied to REF+ convert to all 1s (1111111111), while input voltages less than that applied to REF- convert to all 0s (0000000000). The total unadjusted error may increase as this differential voltage falls below 4.75 V.



TLC1550I, TLC1550M, TLC1551I
10-BIT ANALOG-TO-DIGITAL CONVERTERS
WITH PARALLEL OUTPUTS

SLAS043G – MAY 1991 – REVISED NOVEMBER 2003

**electrical characteristics over recommended operating free-air temperature range,
 $V_{DD} = V_{REF+} = 4.75\text{ V to }5.5\text{ V}$ and $V_{REF-} = 0$ (unless otherwise noted)**

PARAMETER		TEST CONDITIONS	MIN	TYP†	MAX	UNIT
V_{OH}	High-level output voltage	$V_{DD} = 4.75\text{ V}$, $I_{OH} = -360\text{ }\mu\text{A}$	2.4			V
V_{OL}	Low-level output voltage	$V_{DD} = 4.75\text{ V}$, $I_{OL} = 2.4\text{ mA}$, $T_A = 25^\circ\text{C}$			0.4	V
		$T_A = -55^\circ\text{C to }125^\circ\text{C}$			0.5	
I_{OZ}	Off-state (high-impedance-state) output current	$V_O = V_{DD}$, \overline{CS} and \overline{RD} at V_{DD}			10	μA
		$V_O = 0$, \overline{CS} and \overline{RD} at V_{DD}			-10	
I_{IH}	High-level input current	$V_I = V_{DD}$		0.005	2.5	μA
I_{IL}	Low-level input current (except CLKIN)	$V_I = 0$	-2.5	-0.005		μA
I_{IL}	Low-level input current (CLKIN)		-50	-50		μA
I_{OS}	Short-circuit output current	$V_O = 5\text{ V}$, $T_A = 25^\circ\text{C}$	7	14		mA
		$V_O = 0$, $T_A = 25^\circ\text{C}$			-12 -6	
$I_{(DD)}$	Operating supply current	\overline{CS} low and \overline{RD} high		2	8	mA
C_i	Input capacitance	Analog inputs		60	90*	pF
		Digital inputs	See typical equivalent inputs TLC1550/11	5	15*	

* On products compliant to MIL-STD-883, Class B, this parameter is not production tested.

† All typical values are at $V_{DD} = 5\text{ V}$, $T_A = 25^\circ\text{C}$.

TLC1550I, TLC1550M, TLC1551I

10-BIT ANALOG-TO-DIGITAL CONVERTERS

WITH PARALLEL OUTPUTS

SLAS043G – MAY 1991 – REVISED NOVEMBER 2003

operating characteristics over recommended operating free-air temperature range with internal clock and minimum sampling time of 4 μ s, $V_{DD} = V_{REF+} = 5$ V and $V_{REF-} = 0$ (unless otherwise noted)

PARAMETER		TEST CONDITIONS	T_A †	MIN	TYP‡	MAX	UNIT
E _L	Linearity error	See Note 3	Full range			±0.5	LSB
			25°C			±1	
			Full range			±0.5	
E _{ZS}	Zero-scale error	See Notes 2 and 4	Full range			±0.5	LSB
			25°C			±1	
			Full range			±0.5	
E _{FS}	Full-scale error	See Notes 2 and 4	Full range			±0.5	LSB
			25°C			±1	
			Full range			±0.5	
Total unadjusted error		See Note 5	Full range			±0.5	LSB
			25°C			±1	
			Full range			±0.5	
t _c	Conversion time	f _{clock(external)} = 4.2 MHz or internal clock				6	μ s
t _{a(D)}	Data access time after \overline{RD} goes low	See Figure 3				35	ns
t _{v(D)}	Data valid time after \overline{RD} goes high			5			ns
t _{dis(D)}	Disable time, delay time from \overline{RD} high to high impedance					30	ns
t _{d(EOC)}	Delay time, \overline{RD} low to \overline{EOC} high			0	15		ns

† Full range is -40°C to 85°C for the TL155xl devices and -55°C to 125°C for the TLC1550M.

‡ All typical values are at $V_{DD} = 5$ V, $T_A = 25^\circ$ C.

- NOTES:
- Analog input voltages greater than that applied to REF+ convert to all 1s (1111111111), while input voltages less than that applied to REF- convert to all 0s (0000000000). The total unadjusted error may increase as this differential voltage falls below 4.75 V.
 - Linearity error is the difference between the actual analog value at the transition between any two adjacent steps and its ideal value after zero-scale error and full-scale error have been removed.
 - Zero-scale error is the difference between the actual mid-step value and the nominal mid-step value at specified zero scale. Full-scale error is the difference between the actual mid-step value and the nominal mid-step value at specified full scale.
 - Total unadjusted error is the difference between the actual analog value at the transition between any two adjacent steps and its ideal value. It includes contributions from zero-scale error, full-scale error, and linearity error.

PARAMETER MEASUREMENT INFORMATION

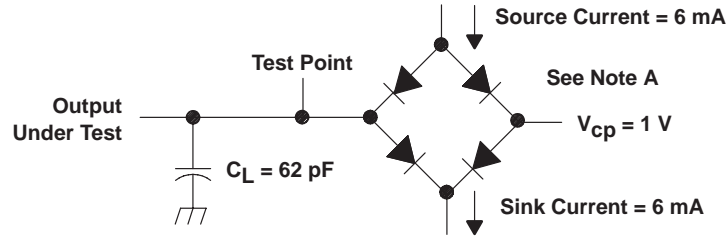

V_{cp} = voltage commutation point for switching between source and sink currents
NOTE A: Equivalent load circuit of the Teradyne A500 tester for timing parameter measurement

Figure 1. Test Load Circuit

TLC1550I, TLC1550M, TLC1551I 10-BIT ANALOG-TO-DIGITAL CONVERTERS WITH PARALLEL OUTPUTS

SLAS043G – MAY 1991 – REVISED NOVEMBER 2003

APPLICATION INFORMATION

simplified analog input analysis

Using the circuit in Figure 2, the time required to charge the analog input capacitance from 0 to V_S within 1/2 LSB can be derived as follows:

The capacitance charging voltage is given by

$$V_C = V_S \left(1 - e^{-t_c / R_t C_i} \right) \quad (1)$$

Where:

$$R_t = R_S + r_i$$

The final voltage to 1/2 LSB is given by

$$V_C (1/2 \text{ LSB}) = V_S - (V_S/1024) \quad (2)$$

Equating equation 1 to equation 2 and solving for time t_c gives

$$V_S - (V_S/512) = V_S \left(1 - e^{-t_c / R_t C_i} \right) \quad (3)$$

and

$$t_c (1/2 \text{ LSB}) = R_t \times C_i \times \ln(1024) \quad (4)$$

Therefore, with the values given, the time for the analog input signal to settle is

$$t_c (1/2 \text{ LSB}) = (R_S + 1 \text{ k}\Omega) \times 60 \text{ pF} \times \ln(1024) \quad (5)$$

This time must be less than the converter sample time shown in the timing diagrams.

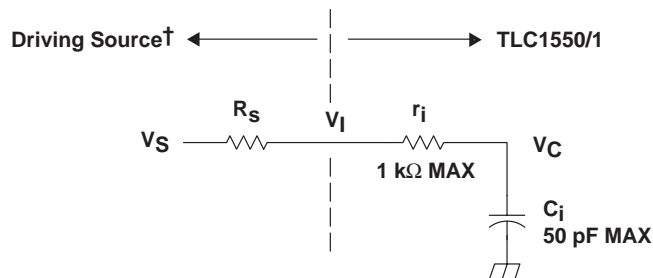

V_I = Input voltage at AIN
 V_S = External driving source voltage
 R_S = Source resistance
 r_i = Input resistance
 C_i = Input capacitance

† Driving source requirements:

- Noise and distortion for the source must be equivalent to the resolution of the converter.
- R_S must be real at the input frequency.

Figure 2. Input Circuit Including the Driving Source

PRINCIPLES OF OPERATION

The operating sequence for complete data acquisition is shown in Figure 3. Processors can address the TLC1550 and TLC1551 as an external memory device by simply connecting the address lines to a decoder and the decoder output to \overline{CS} . Like other peripheral devices, the write (\overline{WR}) and read (\overline{RD}) input signals are valid only when \overline{CS} is low. Once \overline{CS} is low, the onboard system clock permits the conversion to begin with a simple write command and the converted data to be presented to the data bus with a simple read command. The device remains in a sampling (track) mode from the rising edge of \overline{EOC} until conversion begins with the rising edge of \overline{WR} , which initiates the hold mode. After the hold mode begins, the clock controls the conversion automatically. When the conversion is complete, the end-of-conversion (\overline{EOC}) signal goes low indicating that the digital data has been transferred to the output latch. Lowering \overline{CS} and \overline{RD} then resets \overline{EOC} and transfers the data to the data bus for the processor read cycle.

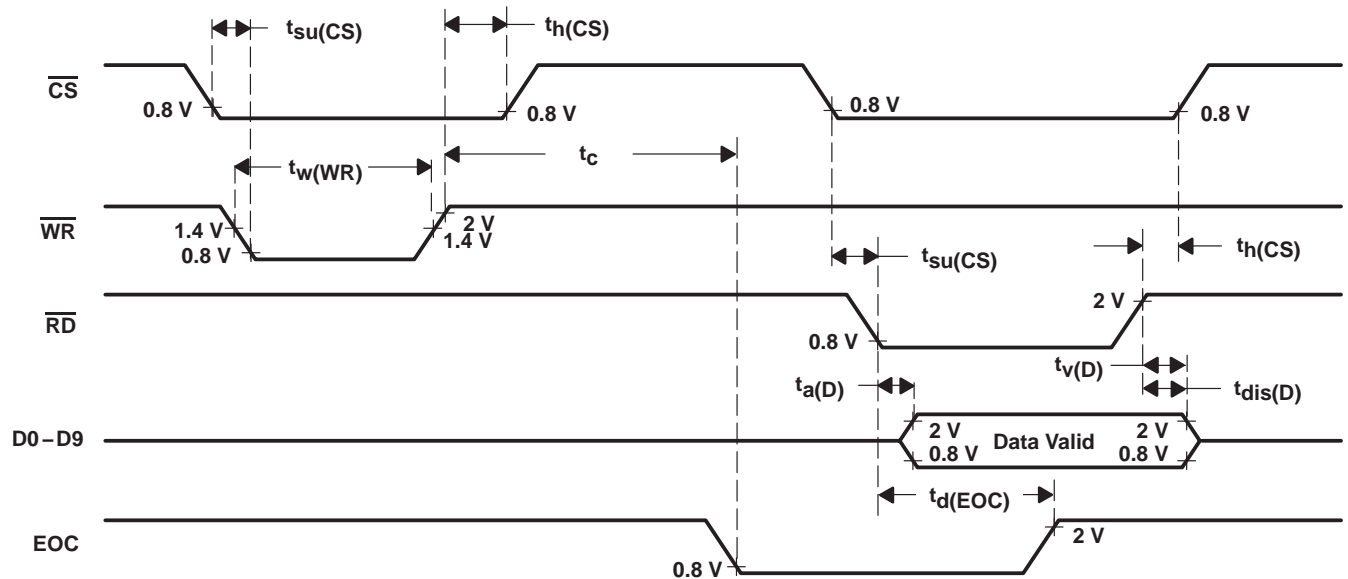

Figure 3. TLC1550 or TLC1551 Operating Sequence

PACKAGING INFORMATION

Orderable Device	Status (1)	Package Type	Package Drawing	Pins	Package Qty	Eco Plan (2)	Lead/Ball Finish (6)	MSL Peak Temp (3)	Op Temp (°C)	Device Marking (4/5)	Samples
TLC1550IDW	ACTIVE	SOIC	DW	24	25	Green (RoHS & no Sb/Br)	CU NIPDAU	Level-1-260C-UNLIM	-40 to 85	TLC1550I	Samples
TLC1550IDWR	ACTIVE	SOIC	DW	24	2000	Green (RoHS & no Sb/Br)	CU NIPDAU	Level-1-260C-UNLIM	-40 to 85	TLC1550I	Samples
TLC1550IFN	ACTIVE	PLCC	FN	28	37	Green (RoHS & no Sb/Br)	CU NIPDAU	Level-1-260C-UNLIM	-40 to 85	TLC1550IFN	Samples
TLC1551IDW	ACTIVE	SOIC	DW	24	25	Green (RoHS & no Sb/Br)	CU NIPDAU	Level-1-260C-UNLIM	-40 to 85	TLC1551I	Samples
TLC1551IDWG4	ACTIVE	SOIC	DW	24	25	Green (RoHS & no Sb/Br)	CU NIPDAU	Level-1-260C-UNLIM	-40 to 85	TLC1551I	Samples
TLC1551IDWR	ACTIVE	SOIC	DW	24	2000	Green (RoHS & no Sb/Br)	CU NIPDAU	Level-1-260C-UNLIM	-40 to 85	TLC1551I	Samples
TLC1551IFN	ACTIVE	PLCC	FN	28	37	Green (RoHS & no Sb/Br)	CU NIPDAU	Level-1-260C-UNLIM	-40 to 85	TLC1551IFN	Samples

(1) The marketing status values are defined as follows:

ACTIVE: Product device recommended for new designs.

LIFEBUY: TI has announced that the device will be discontinued, and a lifetime-buy period is in effect.

NRND: Not recommended for new designs. Device is in production to support existing customers, but TI does not recommend using this part in a new design.

PREVIEW: Device has been announced but is not in production. Samples may or may not be available.

OBSOLETE: TI has discontinued the production of the device.

(2) **RoHS:** TI defines "RoHS" to mean semiconductor products that are compliant with the current EU RoHS requirements for all 10 RoHS substances, including the requirement that RoHS substance do not exceed 0.1% by weight in homogeneous materials. Where designed to be soldered at high temperatures, "RoHS" products are suitable for use in specified lead-free processes. TI may reference these types of products as "Pb-Free".

RoHS Exempt: TI defines "RoHS Exempt" to mean products that contain lead but are compliant with EU RoHS pursuant to a specific EU RoHS exemption.

Green: TI defines "Green" to mean the content of Chlorine (Cl) and Bromine (Br) based flame retardants meet JS709B low halogen requirements of <=100ppm threshold. Antimony trioxide based flame retardants must also meet the <=1000ppm threshold requirement.

(3) MSL, Peak Temp. - The Moisture Sensitivity Level rating according to the JEDEC industry standard classifications, and peak solder temperature.

(4) There may be additional marking, which relates to the logo, the lot trace code information, or the environmental category on the device.

(5) Multiple Device Markings will be inside parentheses. Only one Device Marking contained in parentheses and separated by a "-" will appear on a device. If a line is indented then it is a continuation of the previous line and the two combined represent the entire Device Marking for that device.

⁽⁶⁾ Lead/Ball Finish - Orderable Devices may have multiple material finish options. Finish options are separated by a vertical ruled line. Lead/Ball Finish values may wrap to two lines if the finish value exceeds the maximum column width.

Important Information and Disclaimer: The information provided on this page represents TI's knowledge and belief as of the date that it is provided. TI bases its knowledge and belief on information provided by third parties, and makes no representation or warranty as to the accuracy of such information. Efforts are underway to better integrate information from third parties. TI has taken and continues to take reasonable steps to provide representative and accurate information but may not have conducted destructive testing or chemical analysis on incoming materials and chemicals. TI and TI suppliers consider certain information to be proprietary, and thus CAS numbers and other limited information may not be available for release.

In no event shall TI's liability arising out of such information exceed the total purchase price of the TI part(s) at issue in this document sold by TI to Customer on an annual basis.

TAPE AND REEL INFORMATION

QUADRANT ASSIGNMENTS FOR PIN 1 ORIENTATION IN TAPE

*All dimensions are nominal

Device	Package Type	Package Drawing	Pins	SPQ	Reel Diameter (mm)	Reel Width W1 (mm)	A0 (mm)	B0 (mm)	K0 (mm)	P1 (mm)	W (mm)	Pin1 Quadrant
TLC1550IDWR	SOIC	DW	24	2000	330.0	24.4	10.75	15.7	2.7	12.0	24.0	Q1
TLC1551IDWR	SOIC	DW	24	2000	330.0	24.4	10.75	15.7	2.7	12.0	24.0	Q1

TAPE AND REEL BOX DIMENSIONS

*All dimensions are nominal

Device	Package Type	Package Drawing	Pins	SPQ	Length (mm)	Width (mm)	Height (mm)
TLC1550IDWR	SOIC	DW	24	2000	350.0	350.0	43.0
TLC1551IDWR	SOIC	DW	24	2000	350.0	350.0	43.0

DW (R-PDSO-G24)

PLASTIC SMALL OUTLINE



- NOTES:
- A. All linear dimensions are in inches (millimeters). Dimensioning and tolerancing per ASME Y14.5M-1994.
 - B. This drawing is subject to change without notice.
 - C. Body dimensions do not include mold flash or protrusion not to exceed 0.006 (0,15).
 - D. Falls within JEDEC MS-013 variation AD.

FN 28

GENERIC PACKAGE VIEW

PLCC - 4.57 mm max height

PLASTIC CHIP CARRIER



Images above are just a representation of the package family, actual package may vary.
Refer to the product data sheet for package details.

4040005-3/C



PACKAGE OUTLINE

FN0028A

PLCC - 4.57 mm max height

PLASTIC CHIP CARRIER

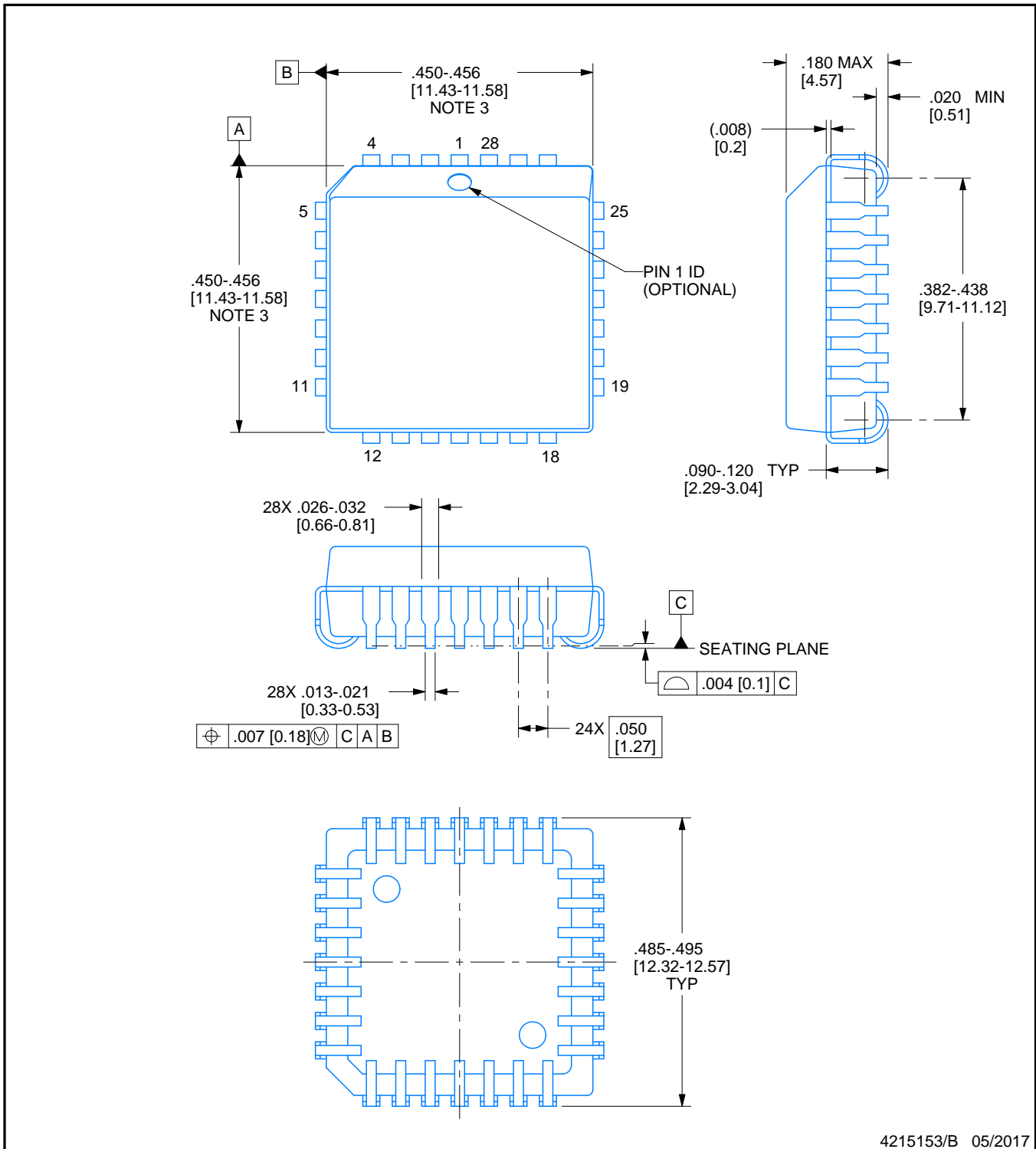

4215153/B 05/2017

NOTES:

1. All linear dimensions are in inches. Any dimensions in brackets are in millimeters. Any dimensions in parenthesis are for reference only. Controlling dimensions are in inches. Dimensioning and tolerancing per ASME Y14.5M.
2. This drawing is subject to change without notice.
3. Dimension does not include mold protrusion. Maximum allowable mold protrusion .01 in [0.25 mm] per side.
4. Reference JEDEC registration MS-018.

EXAMPLE BOARD LAYOUT

FN0028A

PLCC - 4.57 mm max height

PLASTIC CHIP CARRIER

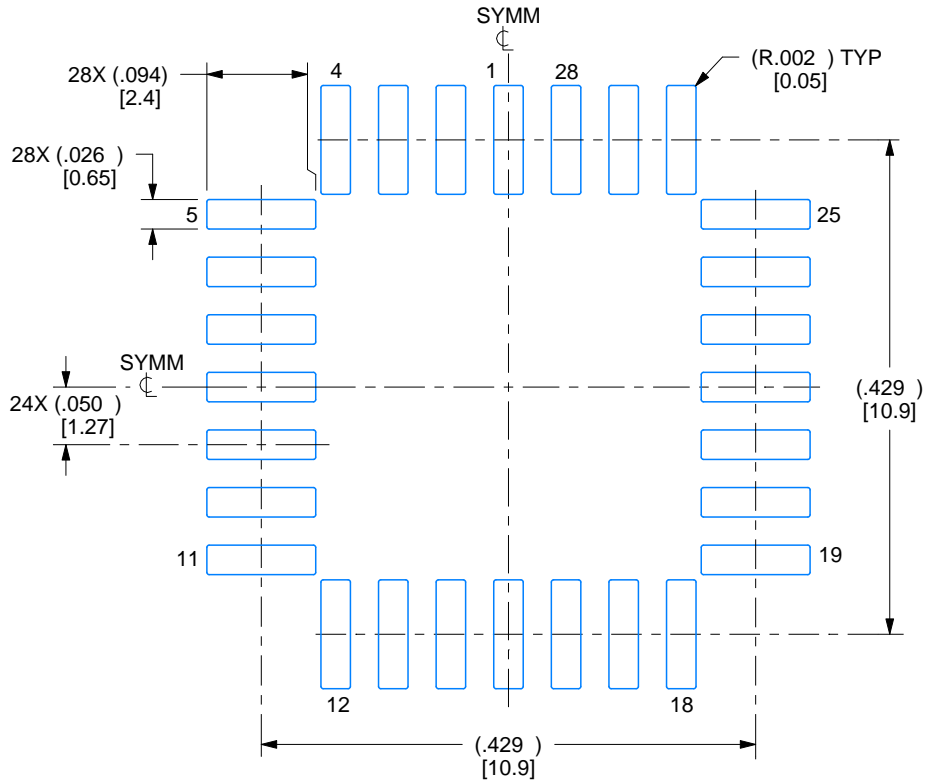

LAND PATTERN EXAMPLE
EXPOSED METAL SHOWN
SCALE:6X

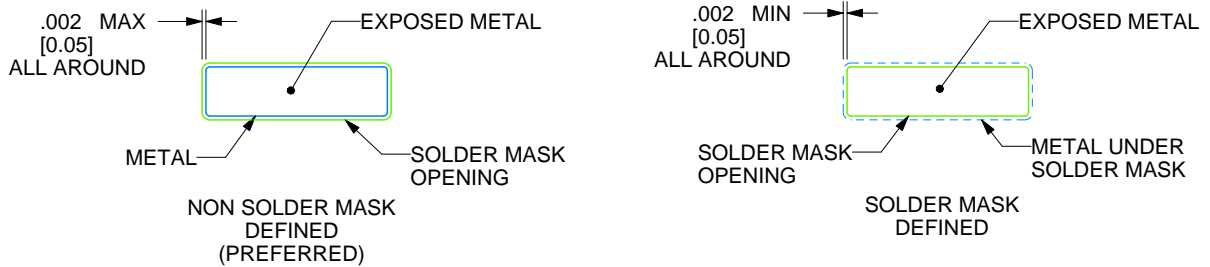

SOLDER MASK DETAILS

4215153/B 05/2017

NOTES: (continued)

- 5. Publication IPC-7351 may have alternate designs.
- 6. Solder mask tolerances between and around signal pads can vary based on board fabrication site.

EXAMPLE STENCIL DESIGN

FN0028A

PLCC - 4.57 mm max height

PLASTIC CHIP CARRIER

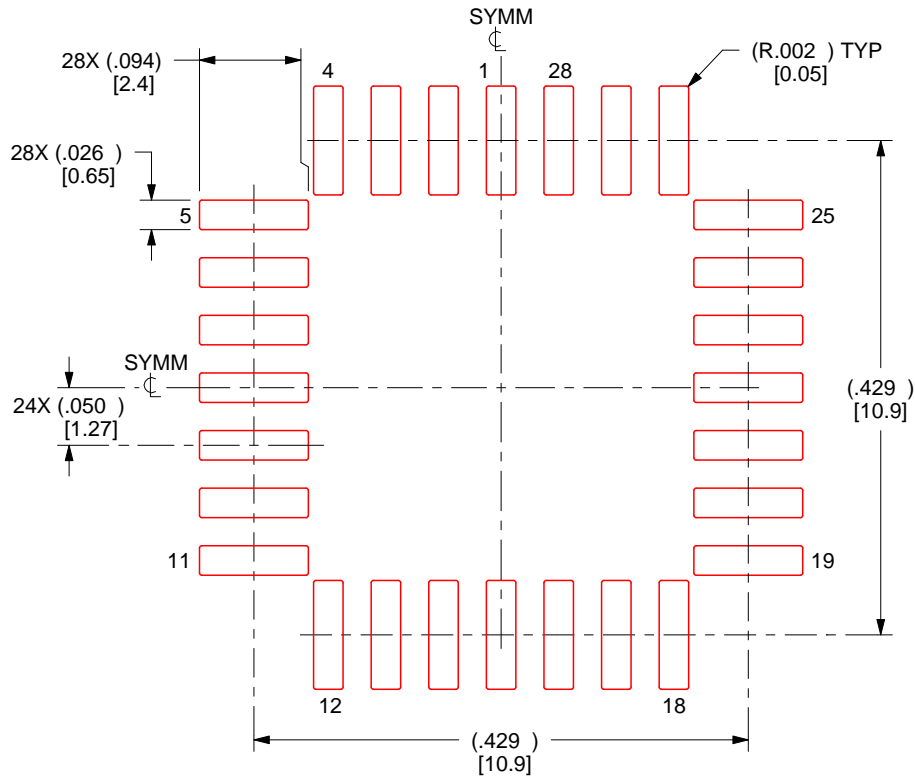

SOLDER PASTE EXAMPLE
BASED ON 0.125 mm THICK STENCIL
SCALE:6X

4215153/B 05/2017

NOTES: (continued)

7. Laser cutting apertures with trapezoidal walls and rounded corners may offer better paste release. IPC-7525 may have alternate design recommendations.
8. Board assembly site may have different recommendations for stencil design.

IMPORTANT NOTICE AND DISCLAIMER

TI PROVIDES TECHNICAL AND RELIABILITY DATA (INCLUDING DATASHEETS), DESIGN RESOURCES (INCLUDING REFERENCE DESIGNS), APPLICATION OR OTHER DESIGN ADVICE, WEB TOOLS, SAFETY INFORMATION, AND OTHER RESOURCES "AS IS" AND WITH ALL FAULTS, AND DISCLAIMS ALL WARRANTIES, EXPRESS AND IMPLIED, INCLUDING WITHOUT LIMITATION ANY IMPLIED WARRANTIES OF MERCHANTABILITY, FITNESS FOR A PARTICULAR PURPOSE OR NON-INFRINGEMENT OF THIRD PARTY INTELLECTUAL PROPERTY RIGHTS.

These resources are intended for skilled developers designing with TI products. You are solely responsible for (1) selecting the appropriate TI products for your application, (2) designing, validating and testing your application, and (3) ensuring your application meets applicable standards, and any other safety, security, or other requirements. These resources are subject to change without notice. TI grants you permission to use these resources only for development of an application that uses the TI products described in the resource. Other reproduction and display of these resources is prohibited. No license is granted to any other TI intellectual property right or to any third party intellectual property right. TI disclaims responsibility for, and you will fully indemnify TI and its representatives against, any claims, damages, costs, losses, and liabilities arising out of your use of these resources.

TI's products are provided subject to TI's Terms of Sale (www.ti.com/legal/termsofsale.html) or other applicable terms available either on ti.com or provided in conjunction with such TI products. TI's provision of these resources does not expand or otherwise alter TI's applicable warranties or warranty disclaimers for TI products.

Mailing Address: Texas Instruments, Post Office Box 655303, Dallas, Texas 75265
Copyright © 2019, Texas Instruments Incorporated

Looking for pricing, stock, or lifecycle information?

Click below to explore more details on WIN SOURCE:

 [View TLC1550IFNR on WIN SOURCE](#)

 [Texas Instruments](#) Information

Optimize Your Supply Chain with WIN SOURCE Solutions

-  Global Sourcing Solution
-  Obsolete Management
-  Cost Control Management
-  Shortage Management
-  Alternative Solution
-  Excess Inventory Management