



THE DATASHEET OF TLC2933IPWR



TLC2933 HIGH-PERFORMANCE PHASE-LOCKED LOOP

SLAS136B – APRIL 1996 – REVISED JANUARY 2002

- **Voltage-Controlled Oscillator (VCO) Section:**
 - Ring Oscillator Using Only One External Bias Resistor (R_{BIAS})
 - Lock Frequency:
 - 43 MHz to 100 MHz ($V_{DD} = 5\text{ V} \pm 5\%$, $T_A = -20^\circ\text{C}$ to 75°C , $\times 1$ Output)
 - 37 MHz to 55 MHz ($V_{DD} = 3\text{ V} \pm 5\%$, $T_A = -20^\circ\text{C}$ to 75°C)
- **Phase-Frequency Detector (PFD) Section Includes a High-Speed Edge-Triggered Detector With Internal Charge Pump**
- **Independent VCO, PFD Power-Down Mode**
- **Thin Small-Outline Package (14 terminal)**
- **CMOS Technology**
- **Typical Applications:**
 - Frequency Synthesis
 - Modulation/Demodulation
 - Fractional Frequency Division
- **CMOS Input Logic Level**

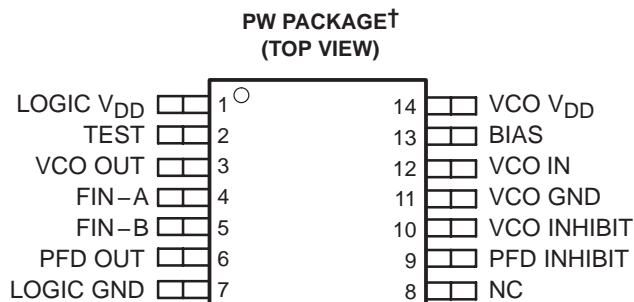

† Available in tape and reel only and ordered as the TLC2933IPWR.

NC – No internal connection

description

The TLC2933 is designed for phase-locked-loop (PLL) systems and is composed of a voltage-controlled oscillator (VCO) and an edge-triggered-type phase frequency detector (PFD). The oscillation frequency range of the VCO is set by an external bias resistor (R_{BIAS}). The high-speed PFD with internal charge pump detects the phase difference between the reference frequency input and signal frequency input from the external counter. Both the VCO and the PFD have inhibit functions that can be used as a power-down mode. With the high-speed and stable VCO characteristics, the TLC2933 is well suited for use in high-performance PLL systems.

functional block diagram

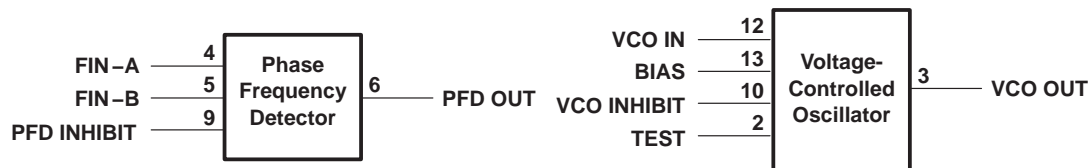

AVAILABLE OPTIONS

T_A	PACKAGE
	-20°C to 75°C

† The PW package is available taped and reeled. Add an R suffix to device type (e.g., TLC2933IPWR).



Please be aware that an important notice concerning availability, standard warranty, and use in critical applications of Texas Instruments semiconductor products and disclaimers thereto appears at the end of this data sheet.

PRODUCTION DATA information is current as of publication date. Products conform to specifications per the terms of Texas Instruments standard warranty. Production processing does not necessarily include testing of all parameters.

**TEXAS
INSTRUMENTS**

POST OFFICE BOX 655303 • DALLAS, TEXAS 75265

Copyright © 2002, Texas Instruments Incorporated

TLC2933

HIGH-PERFORMANCE PHASE-LOCKED LOOP

SLAS136B – APRIL 1996 – REVISED JANUARY 2002

Terminal Functions

TERMINAL NAME	NO.	I/O	DESCRIPTION
BIAS	13	I	Bias supply. An external resistor (R_{BIAS}) between VCO V_{DD} and BIAS supplies bias for adjusting the oscillation frequency range.
FIN-A	4	I	Input reference frequency $f_{(REF IN)}$ is applied to FIN-A.
FIN-B	5	I	Input for VCO external counter output frequency $f_{(FIN-B)}$. FIN-B is nominally provided from the external counter.
LOGIC GND	7		Ground for the internal logic.
LOGIC V_{DD}	1		Power supply for the internal logic. This power supply should be separate from VCO V_{DD} to reduce cross-coupling between supplies.
NC	8		No internal connection.
PFD INHIBIT	9	I	PFD inhibit control. When PFD INHIBIT is high, PFD OUT is in the high-impedance state, see Table 2.
PFD OUT	6	O	PFD output. When the PFD INHIBIT is high, PFD OUT is in the high-impedance state.
TEST	2	I	Test terminal. TEST connects to ground for normal operation.
VCO GND	11		Ground for VCO.
VCO IN	12	I	VCO control voltage input. Nominally the external loop filter output connects to VCO IN to control VCO oscillation frequency.
VCO INHIBIT	10	I	VCO inhibit control. When VCO INHIBIT is high, VCO OUT is low (see Table 1).
VCO OUT	3	O	VCO output. When VCO INHIBIT is high, VCO OUT is low.
VCO V_{DD}	14		Power supply for VCO. This power supply should be separated from LOGIC V_{DD} to reduce cross-coupling between supplies.

detailed description

VCO oscillation frequency

The VCO oscillation frequency is determined by an external resistor (R_{BIAS}) connected between the VCO V_{DD} and the BIAS terminals. The oscillation frequency and range depends on this resistor value. While all resistor values within the specified range result in excellent low temperature coefficients, the bias resistor value for the minimum temperature coefficient is nominally 2.2 k Ω with 3-V V_{DD} and nominally 2.4 k Ω with 5-V V_{DD} . For the lock frequency range refer to the recommended operating conditions. Figure 1 shows the typical frequency variation and VCO control voltage.

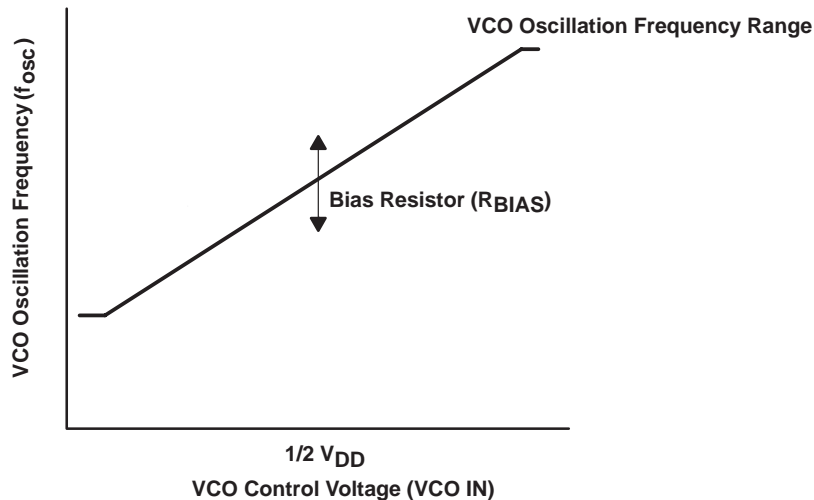

Figure 1. VCO Oscillation Frequency

VCO inhibit function

The VCO has an externally controlled inhibit function which inhibits the VCO output. A high level on the VCO INHIBIT terminal stops the VCO oscillation and powers down the VCO. The output maintains a low level during the power-down mode as shown in Table 1.

Table 1. VCO Inhibit Function

VCO INHIBIT	VCO OSCILLATOR	VCO OUT	I _{DD} (VCO)
Low	Active	Active	Normal
High	Stopped	Low level	Power Down

PFD operation

The PFD is a high-speed, edge-triggered detector with an internal charge pump. The PFD detects the phase difference between two frequency inputs supplied to FIN-A and FIN-B as shown in Figure 2. Nominally the reference is supplied to FIN-A, and the frequency from the external counter output is fed to FIN-B. For clock recovery PLL systems, other types of phase detectors should be used.

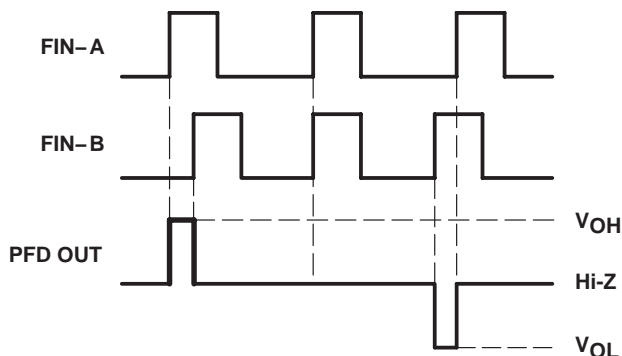

Figure 2. PFD Function Timing Chart

PFD inhibit control

A high level on the PFD INHIBIT terminal places PFD OUT in the high-impedance state and the PFD stops phase detection as shown in Table 2. A high level on the PFD INHIBIT terminal can also be used as the power-down mode for the PFD.

Table 2. VCO Output Control Function

PFD INHIBIT	DETECTION	PFD OUT	I _{DD} (PFD)
Low	Active	Active	Normal
High	Stopped	Hi-Z	Power Down

TLC2933 HIGH-PERFORMANCE PHASE-LOCKED LOOP

SLAS136B – APRIL 1996 – REVISED JANUARY 2002

schematics

VCO block schematic

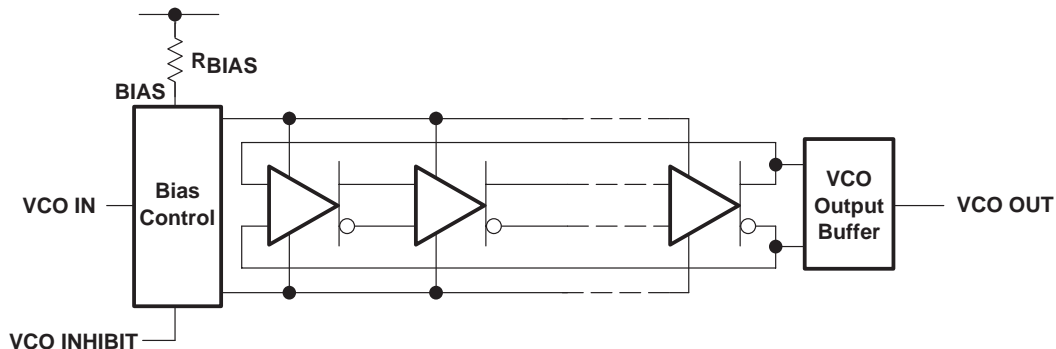

PFD block schematic

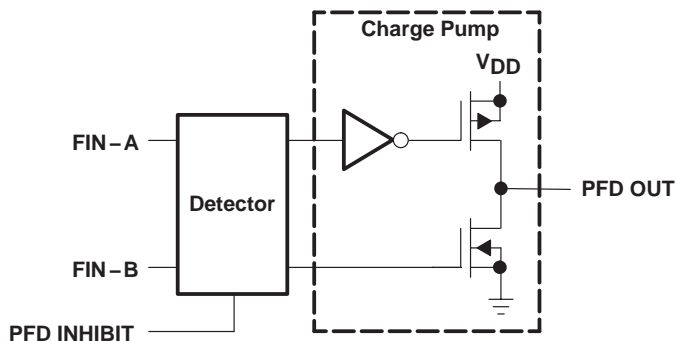

absolute maximum ratings†

Supply voltage (each supply), V _{DD} (see Note 1)	7 V
Input voltage range (each input), V _I (see Note 1)	-0.3 V to V _{DD} + 0.3 V
Input current (each input), I _I	±20 mA
Output current (each output), I _O	±20 mA
Continuous total power dissipation at (or below) T _A = 25°C (see Note 2)	700 mW
Operating free-air temperature range, T _A	-20°C to 75°C
Storage temperature range, T _{stg}	-65°C to 150°C
Lead temperature 1,6 mm (1/16 inch) from case for 10 seconds	260°C

† Stresses beyond those listed under "absolute maximum ratings" may cause permanent damage to the device. These are stress ratings only, and functional operation of the device at these or any other conditions beyond those indicated under "recommended operating conditions" is not implied. Exposure to absolute-maximum-rated conditions for extended periods may affect device reliability.

NOTES: 1. All voltage values are with respect to network ground terminal.

2. For operation above 25°C free-air temperature, derate linearly at the rate of 5.6 mW/°C.

TLC2933 HIGH-PERFORMANCE PHASE-LOCKED LOOP

SLAS136B – APRIL 1996 – REVISED JANUARY 2002

recommended operating conditions

		MIN	NOM	MAX	UNIT
Supply voltage, V_{DD} (each supply, see Note 3)	$V_{DD} = 3\text{ V}$	2.85	3	3.15	V
	$V_{DD} = 5\text{ V}$	4.75	5	5.25	
Input voltage, V_I (inputs except VCO IN)		0		V_{DD}	V
Output current, I_O (each output)		0		± 2	mA
VCO control voltage at VCO IN		1		V_{DD}	V
Lock frequency	$V_{DD} = 3\text{ V}$	37		55	MHz
	$V_{DD} = 5\text{ V}$	43		100	
Bias resistor, R_{BIAS}	$V_{DD} = 3\text{ V}$	1.8		2.7	k Ω
	$V_{DD} = 5\text{ V}$	2.2		3	

NOTE 3: It is recommended that the logic supply terminal (LOGIC V_{DD}) and the VCO supply terminal (VCO V_{DD}) be at the same voltage and separated from each other.

electrical characteristics over recommended operating free-air temperature range, $V_{DD} = 3\text{ V}$ (unless otherwise noted)

VCO section

PARAMETER		TEST CONDITIONS	MIN	TYP	MAX	UNIT
V_{OH}	High-level output voltage	$I_{OH} = -2\text{ mA}$	2.4			V
V_{OL}	Low-level output voltage	$I_{OL} = 2\text{ mA}$			0.3	V
V_{IT+}	Positive input threshold voltage at TEST, VCO INHIBIT		0.9	1.5	2.1	V
I_I	Input current at TEST, VCO INHIBIT	$V_I = V_{DD}$ or ground			± 1	μA
$Z_i(\text{VCO IN})$	Input impedance at VCO IN	VCO IN = $1/2 V_{DD}$		10		M Ω
$I_{DD}(\text{INH})$	VCO supply current (inhibit)	See Note 4		0.01	1	μA
$I_{DD}(\text{VCO})$	VCO supply current	See Note 5		5.1	15	mA

NOTES: 4. The current into VCO V_{DD} and LOGIC V_{DD} when VCO INHIBIT = V_{DD} and PFD INHIBIT is high.

5. The current into VCO V_{DD} and LOGIC V_{DD} when VCO IN = $1/2 V_{DD}$, $R_{BIAS} = 2.4\text{ k}\Omega$, VCO INHIBIT = ground, and PFD INHIBIT is high.

PFD section

PARAMETER		TEST CONDITIONS	MIN	TYP	MAX	UNIT
V_{OH}	High-level output voltage	$I_{OH} = -2\text{ mA}$	2.7			V
V_{OL}	Low-level output voltage	$I_{OL} = 2\text{ mA}$			0.2	V
I_{OZ}	High-impedance-state output current	PFD INHIBIT = high, $V_I = V_{DD}$ or ground			± 1	μA
V_{IH}	High-level input voltage at FIN-A, FIN-B		2.1			V
V_{IL}	Low-level input voltage at FIN-A, FIN-B				0.9	V
V_{IT+}	Positive input threshold voltage at PFD INHIBIT		0.9	1.5	2.1	V
C_i	Input capacitance at FIN-A, FIN-B			5		pF
Z_i	Input impedance at FIN-A, FIN-B			10		M Ω
$I_{DD}(Z)$	High-impedance-state PFD supply current	See Note 6		0.01	1	μA
$I_{DD}(\text{PFD})$	PFD supply current	See Note 7		0.7	4	mA

NOTES: 6. The current into LOGIC V_{DD} when FIN-A and FIN-B = ground, PFD INHIBIT = V_{DD} , PFD OUT open, and VCO OUT is inhibited.

7. The current into LOGIC V_{DD} when FIN-A and FIN-B = 30 MHz ($V_{I(PP)} = 3\text{ V}$, rectangular wave), PFD INHIBIT = GND, PFD OUT open, and VCO OUT is inhibited.



TLC2933

HIGH-PERFORMANCE PHASE-LOCKED LOOP

SLAS136B – APRIL 1996 – REVISED JANUARY 2002

operating characteristics over recommended operating free-air temperature range, $V_{DD} = 3\text{ V}$ (unless otherwise noted)

VCO section

PARAMETER		TEST CONDITIONS	MIN	TYP	MAX	UNIT
f_{osc}	Operating oscillation frequency	$R_{BIAS} = 2.4\text{ k}\Omega$, $VCO\ IN = 1/2\ V_{DD}$	38	48	55	MHz
$t_s(f_{osc})$	Time to stable oscillation (see Note 8)	Measured from VCO INHIBIT \downarrow			10	μs
t_r	Rise time, VCO OUT \uparrow	$C_L = 15\text{ pF}$, See Figure 3		3.3	10	ns
t_f	Fall time, VCO OUT \downarrow	$C_L = 15\text{ pF}$, See Figure 3		2	8	ns
	Duty cycle at VCO OUT	$R_{BIAS} = 2.4\text{ k}\Omega$, $VCO\ IN = 1/2\ V_{DD}$	45%	50%	55%	
$\alpha(f_{osc})$	Temperature coefficient of oscillation frequency	$R_{BIAS} = 2.4\text{ k}\Omega$, $VCO\ IN = 1/2\ V_{DD}$, $T_A = -20^\circ\text{C}$ to 75°C		0.03		$\%/^\circ\text{C}$
$k_{SVS}(f_{osc})$	Supply voltage coefficient of oscillation frequency	$R_{BIAS} = 2.4\text{ k}\Omega$, $VCO\ IN = 1.5\text{ V}$, $V_{DD} = 2.85\text{ V}$ to 3.15 V		0.04		$\%/mV$
	Jitter absolute (see Note 9)	$R_{BIAS} = 2.4\text{ k}\Omega$		100		ps

NOTES: 8. The time period to stabilize the VCO oscillation frequency after the VCO INHIBIT terminal is changed to a low level.
9. Jitter performance is highly dependent on circuit layout and external device characteristics. The jitter specification was made with a carefully designed printed circuit board (PCB) with no device socket.

PFD section

PARAMETER		TEST CONDITIONS	MIN	TYP	MAX	UNIT
f_{max}	Maximum operating frequency		30			MHz
t_{PLZ}	Disable time, PFD INHIBIT \uparrow to PFD OUT Hi-Z	See Figures 4 and 5 and Table 3		20	40	ns
t_{PHZ}	Disable time, PFD INHIBIT \uparrow to PFD OUT Hi-Z			18	40	
t_{PZL}	Enable time, PFD INHIBIT \downarrow to PFD OUT low			4.1	18	ns
t_{PZH}	Enable time, PFD INHIBIT \downarrow to PFD OUT high			4.8	18	
t_r	Rise time, PFD OUT \uparrow	$C_L = 15\text{ pF}$, See Figure 4		3.1	9	ns
t_f	Fall time, PFD OUT \downarrow			1.5	9	ns



TLC2933 HIGH-PERFORMANCE PHASE-LOCKED LOOP

SLAS136B – APRIL 1996 – REVISED JANUARY 2002

electrical characteristics over recommended operating free-air temperature range, $V_{DD} = 5\text{ V}$ (unless otherwise noted)

VCO section

PARAMETER		TEST CONDITIONS	MIN	TYP	MAX	UNIT
V_{OH}	High-level output voltage	$I_{OH} = -2\text{ mA}$	4.5			V
V_{OL}	Low-level output voltage	$I_{OL} = 2\text{ mA}$			0.5	V
V_{IT+}	Positive input threshold voltage at TEST, VCO INHIBIT		1.5	2.5	3.5	V
I_I	Input current at TEST, VCO INHIBIT	$V_I = V_{DD}$ or ground			± 1	μA
$Z_i(\text{VCO IN})$	Input impedance at VCO IN	$V_{CO IN} = 1/2 V_{DD}$		10		$\text{M}\Omega$
$I_{DD}(\text{INH})$	VCO supply current (inhibit)	See Note 4		0.01	1	μA
$I_{DD}(\text{VCO})$	VCO supply current	See Note 5		14	35	mA

NOTES: 4. The current into VCO V_{DD} and LOGIC V_{DD} when VCO INHIBIT = V_{DD} , and PFD INHIBIT high.
5. The current into VCO V_{DD} and LOGIC V_{DD} when VCO IN = $1/2 V_{DD}$, $R_{BIAS} = 2.4\text{ k}\Omega$, VCO INHIBIT = ground, and PFD INHIBIT high.

PFD section

PARAMETER		TEST CONDITIONS	MIN	TYP	MAX	UNIT
V_{OH}	High-level output voltage	$I_{OH} = 2\text{ mA}$	4.5			V
V_{OL}	Low-level output voltage	$I_{OL} = 2\text{ mA}$			0.2	V
I_{OZ}	High-impedance-state output current	PFD INHIBIT = high, $V_I = V_{DD}$ or ground			± 1	μA
V_{IH}	High-level input voltage at FIN-A, FIN-B		3.5			V
V_{IL}	Low-level input voltage at FIN-A, FIN-B				1.5	V
V_{IT+}	Positive input threshold voltage at PFD INHIBIT		1.5	2.5	3.5	V
C_i	Input capacitance at FIN-A, FIN-B			7		pF
Z_i	Input impedance at FIN-A, FIN-B			10		$\text{M}\Omega$
$I_{DD}(\text{Z})$	High-impedance-state PFD supply current	See Note 6		0.01	1	μA
$I_{DD}(\text{PFD})$	PFD supply current	See Note 10		2.6	8	mA

NOTES: 6. The current into LOGIC V_{DD} when FIN-A and FIN-B = ground, PFD INHIBIT = V_{DD} , PFD OUT open, and VCO OUT is inhibited.
10. The current into LOGIC V_{DD} when FIN-A and FIN-B = 50 MHz ($V_{I(\text{PP})} = 3\text{ V}$, rectangular wave), PFD INHIBIT = ground, PFD OUT open, and VCO OUT is inhibited.

TLC2933

HIGH-PERFORMANCE PHASE-LOCKED LOOP

SLAS136B – APRIL 1996 – REVISED JANUARY 2002

operating characteristics over recommended operating free-air temperature range, $V_{DD} = 5\text{ V}$ (unless otherwise noted)

VCO section

PARAMETER		TEST CONDITIONS	MIN	TYP	MAX	UNIT
f_{osc}	Operating oscillation frequency	$R_{BIAS} = 2.4\text{ k}\Omega$, $VCO\ IN = 1/2\ V_{DD}$	64	80	96	MHz
$t_s(f_{osc})$	Time to stable oscillation (see Note 8)	Measured from VCO INHIBIT \downarrow			10	μs
t_r	Rise time, VCO OUT \uparrow	$C_L = 15\text{ pF}$, See Figure 3		2.1	5	ns
t_f	Fall time, VCO OUT \downarrow	$C_L = 15\text{ pF}$, See Figure 3		1.5	4	ns
	Duty cycle at VCO OUT	$R_{BIAS} = 2.4\text{ k}\Omega$, $VCO\ IN = 1/2\ V_{DD}$	45%	50%	55%	
$\alpha(f_{osc})$	Temperature coefficient of oscillation frequency	$R_{BIAS} = 2.4\text{ k}\Omega$, $VCO\ IN = 1/2\ V_{DD}$, $T_A = -20^\circ\text{C}$ to 75°C		0.03		$\%/^\circ\text{C}$
$k_{SVS}(f_{osc})$	Supply voltage coefficient of oscillation frequency	$R_{BIAS} = 2.4\text{ k}\Omega$, $VCO\ IN = 2.5\text{ V}$, $V_{DD} = 4.75\text{ V}$ to 5.25 V		0.02		$\%/mV$
	Jitter absolute (see Note 9)	$R_{BIAS} = 2.4\text{ k}\Omega$		100		ps

NOTES: 8: The time period to stabilize the VCO oscillation frequency after the VCO INHIBIT terminal is changed to a low level.

9: Jitter performance is highly dependent on circuit layout and external device characteristics. The jitter specification was made with a carefully designed printed circuit board (PCB) with no device socket.

PFD section

PARAMETER		TEST CONDITIONS	MIN	TYP	MAX	UNIT
f_{max}	Maximum operating frequency		50			MHz
t_{PLZ}	Disable time, PFD INHIBIT \uparrow to PFD OUT Hi-Z	See Figures 4 and 5 and Table 3		20	40	ns
t_{PHZ}	Disable time, PFD INHIBIT \uparrow to PFD OUT Hi-Z			17	40	
t_{PZL}	Enable time, PFD INHIBIT \downarrow to PFD OUT low			3.7	10	ns
t_{PZH}	Enable time, PFD INHIBIT \downarrow to PFD OUT high			3.4	10	
t_r	Rise time, PFD OUT \uparrow	$C_L = 15\text{ pF}$, See Figure 4		1.7	5	ns
t_f	Fall time, PFD OUT \downarrow			1.3	5	ns

PARAMETER MEASUREMENT INFORMATION

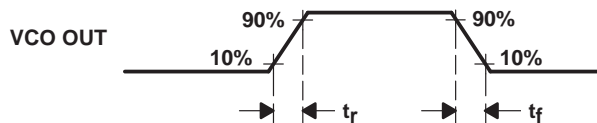
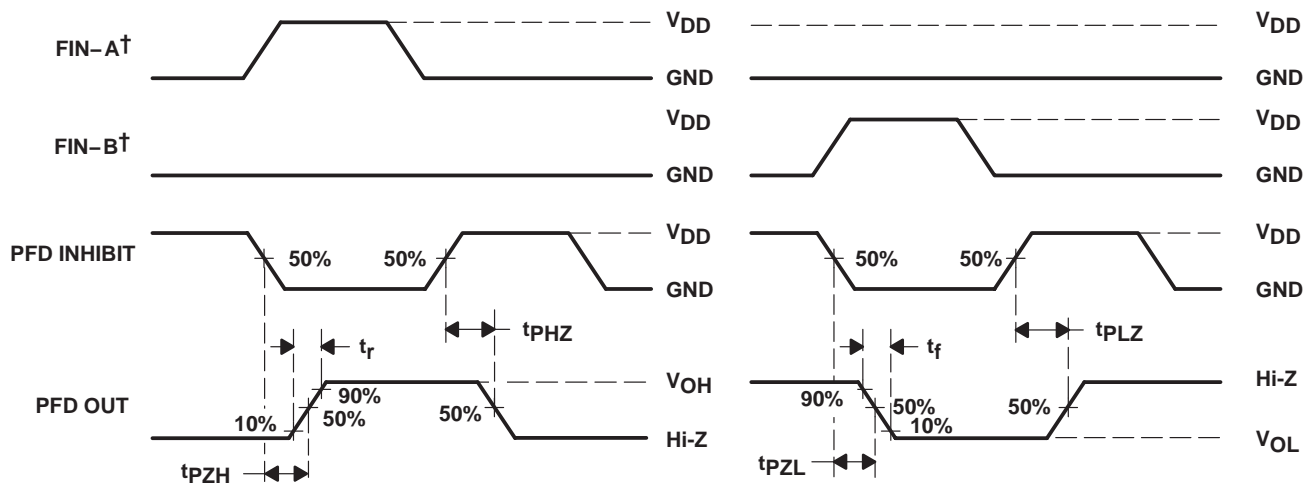

Figure 3. VCO Output Voltage Waveform



(a) PFD OUT Hi-Z Timing To and From a High Level
(see Figure 5 and Table 3)

(b) PFD OUT Hi-Z Timing To and From a Low Level
(see Figure 5 and Table 3)

† FIN-A and FIN-B are for reference phase only, not for timing.

Figure 4. PFD Output Voltage Waveform

Table 3. PFD Output Test Conditions

PARAMETER	RL	CL	S1	S2
tPZH	1 kΩ	15 pF	Open	Closed
tPHZ				
tr				
tPZL			Closed	Open
tPLZ				
tf				

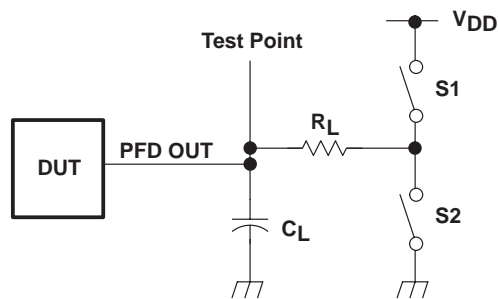

Figure 5. PFD Output Test Conditions

TLC2933 HIGH-PERFORMANCE PHASE-LOCKED LOOP

SLAS136B – APRIL 1996 – REVISED JANUARY 2002

TYPICAL CHARACTERISTICS

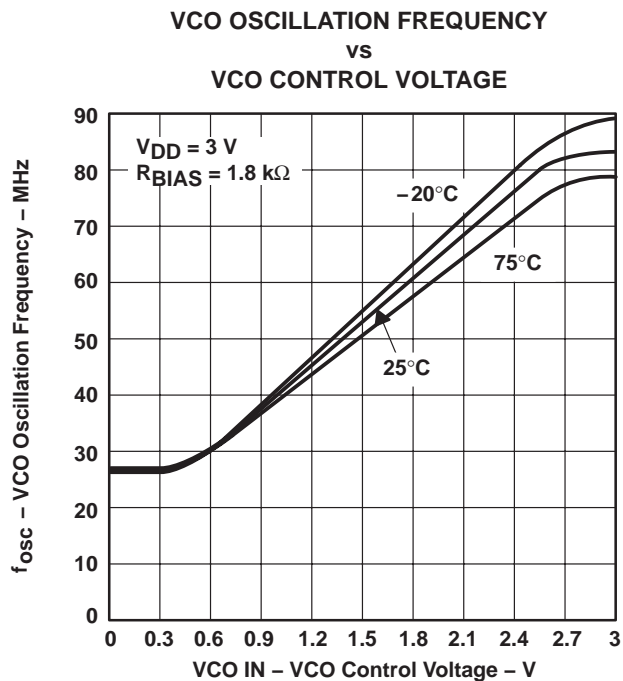

Figure 6

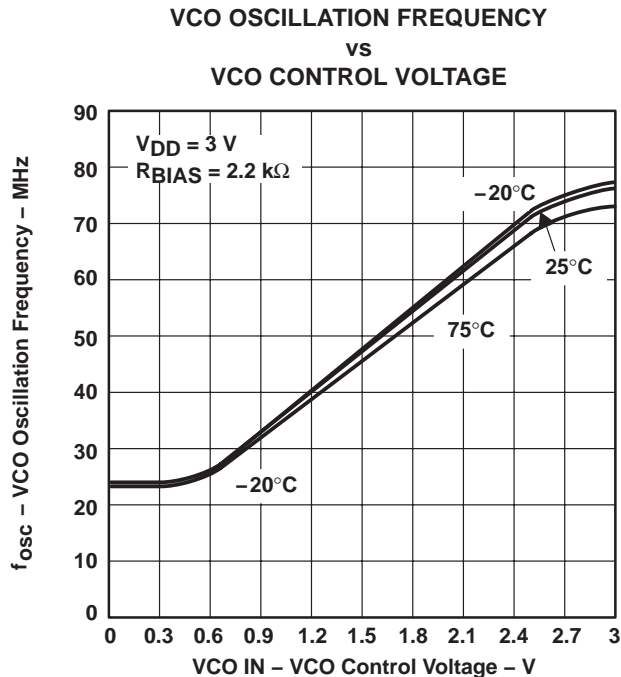

Figure 7

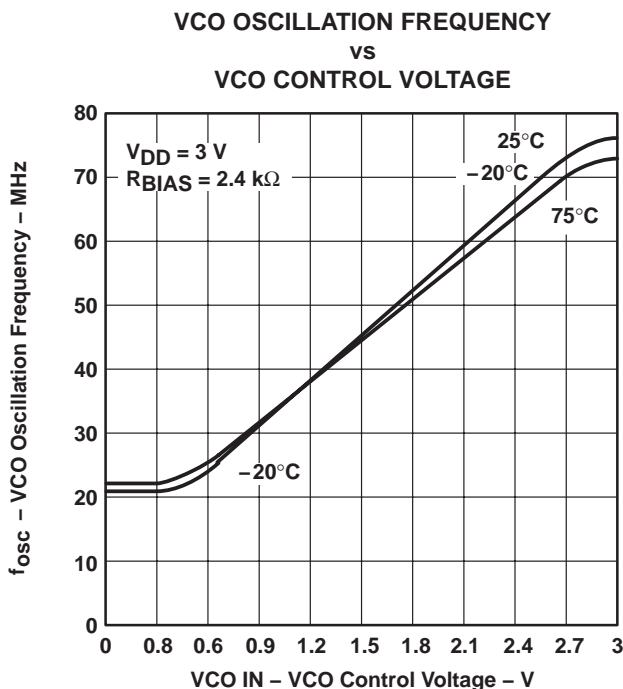

Figure 8

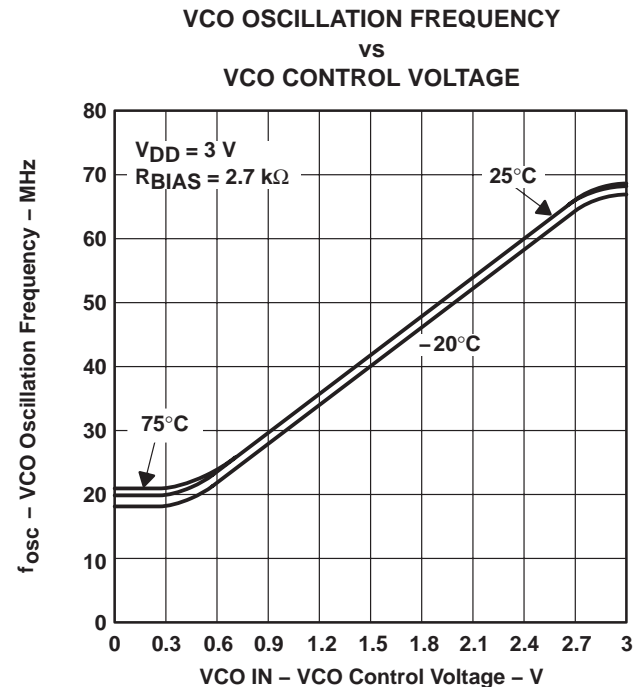

Figure 9

TYPICAL CHARACTERISTICS

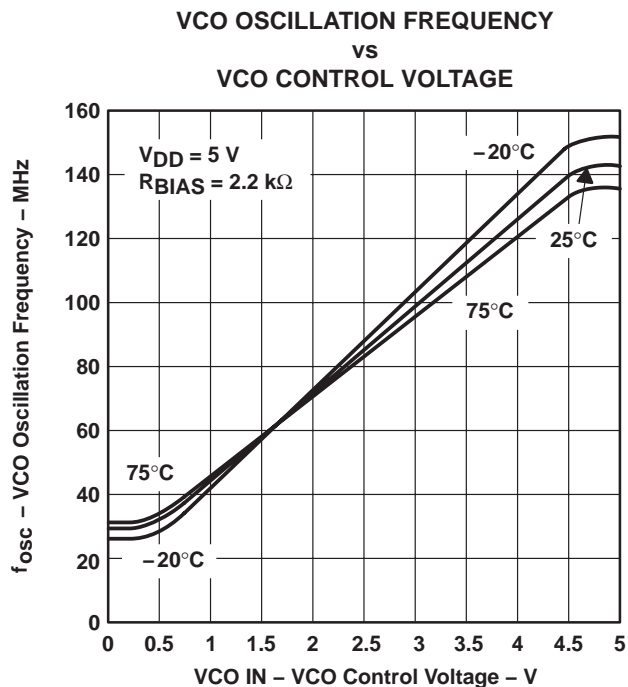

Figure 10

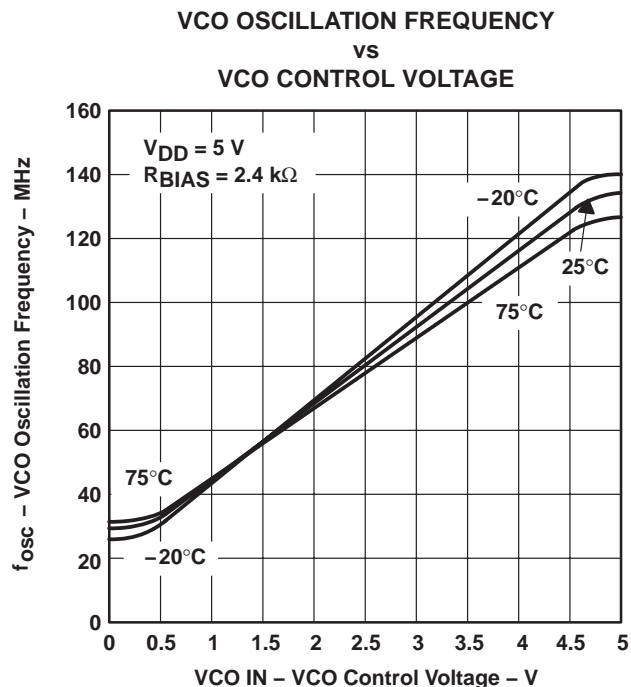

Figure 11

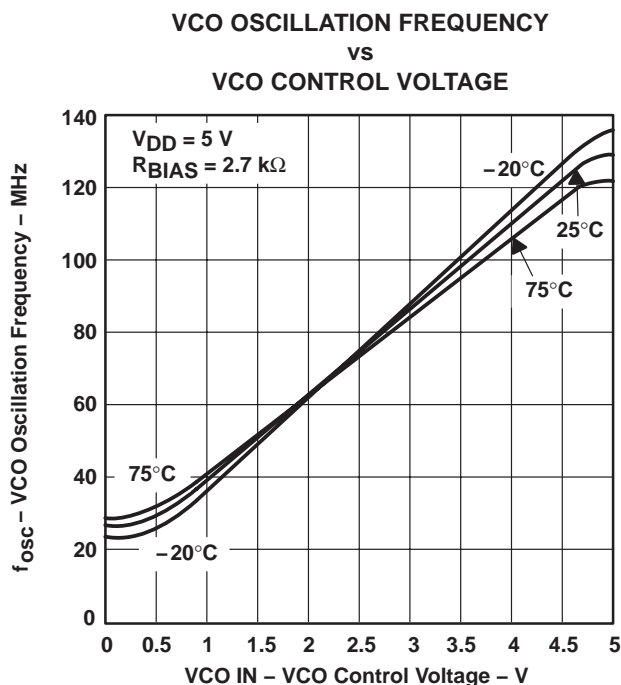

Figure 12

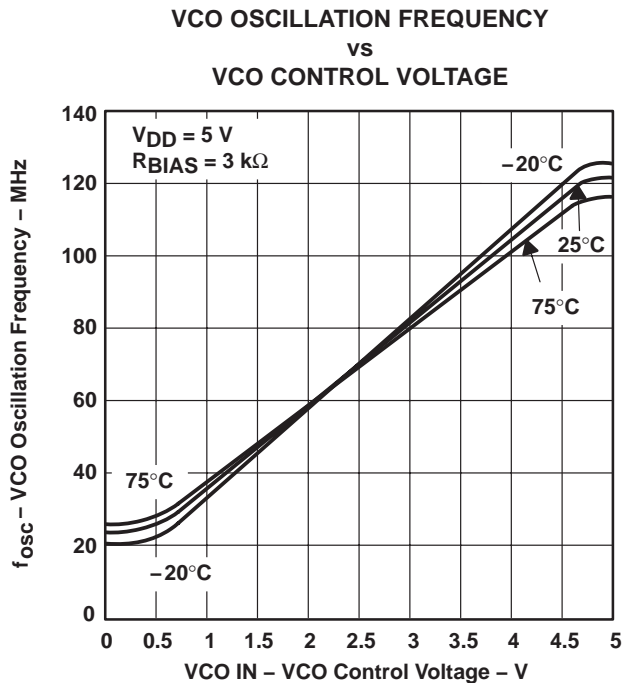

Figure 13

TLC2933 HIGH-PERFORMANCE PHASE-LOCKED LOOP

SLAS136B – APRIL 1996 – REVISED JANUARY 2002

TYPICAL CHARACTERISTICS

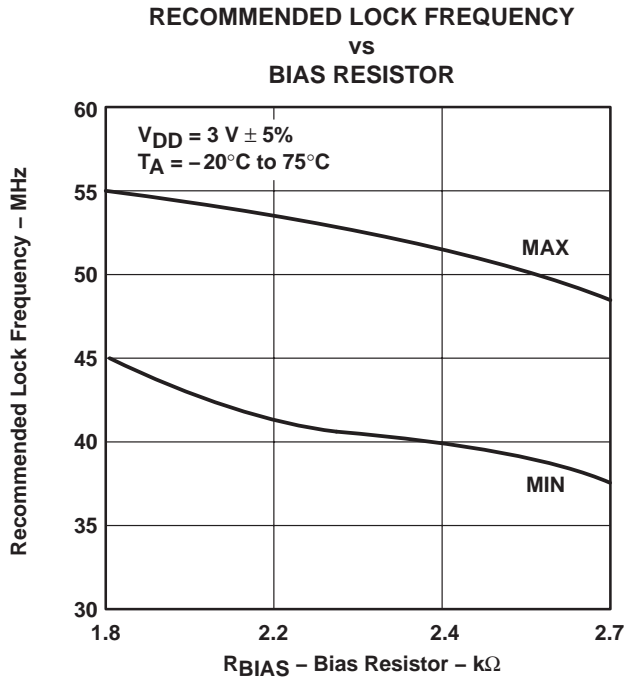

Figure 14

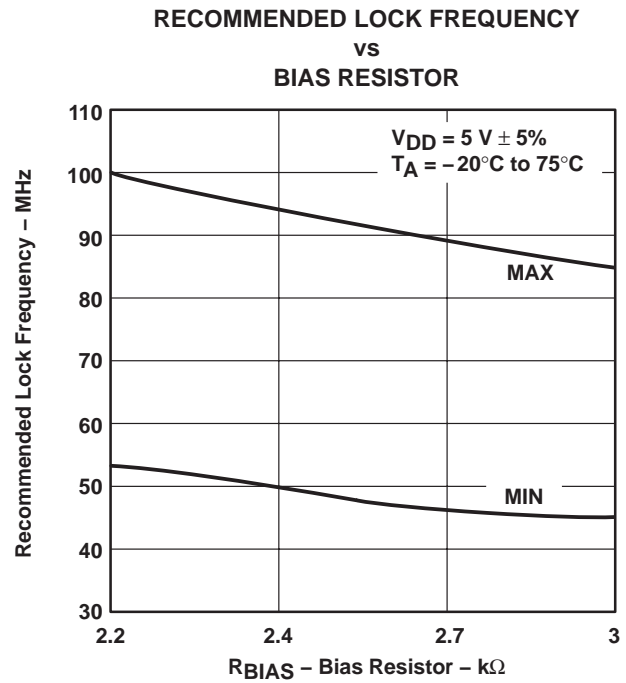

Figure 15

APPLICATION INFORMATION

gain of VCO and PFD

Figure 16 is a block diagram of the PLL. The divider N value depends on the input frequency and the desired VCO output frequency according to the system application requirements. The K_p and K_V values are obtained from the operating characteristics of the device as shown in Figure 16. K_p is defined from the phase detector V_{OL} and V_{OH} specifications and the equation shown in Figure 16(b). K_V is defined from Figures 8, 9, 10, and 11 as shown in Figure 16(c).

The parameters for the block diagram with the units are as follows:

- K_V : VCO gain (rad/s/V)
- K_p : PFD gain (V/rad)
- K_f : LPF gain (V/V)
- K_N : countdown divider gain (1/N)

external counter

When a large N counter is required by the application, there is a possibility that the PLL response becomes slow due to the counter response delay time. In the case of a high frequency application, the counter delay time should be accounted for in the overall PLL design.

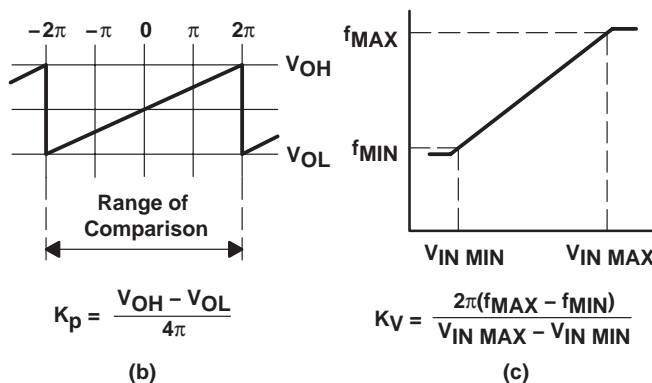
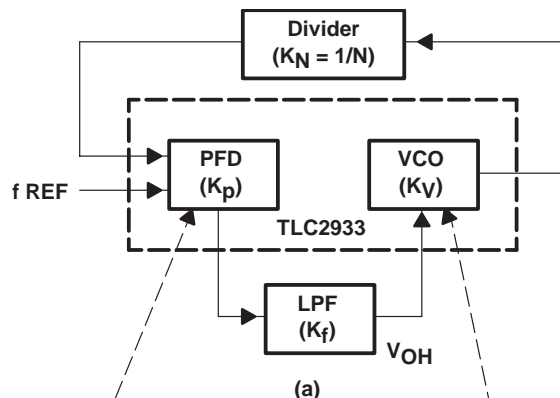

Figure 16. Example of a PLL Block Diagram

RBIAS

The external bias resistor sets the VCO center frequency with $1/2 V_{DD}$ applied to the VCO IN terminal. For the most accurate results, a metal-film resistor is the better choice but a carbon-composition resistor can also be used with excellent results. A $0.22 \mu F$ capacitor should be connected from the BIAS terminal to ground as close to the device terminals as possible.

hold-in range

From the technical literature, the maximum hold-in range for an input frequency step for the three types of filter configurations shown in Figure 17 is as follows:

$$\Delta\omega_H \approx 0.8 (K_p) (K_V) (K_f(\infty)) \tag{1}$$

Where

$K_f(\infty)$ = the filter transfer function value at $\omega = \infty$

APPLICATION INFORMATION

low-pass-filter (LPF) configurations

Many excellent references are available that include detailed design information about LPFs and should be consulted for additional information. Lag-lead filters or active filters are often used. Examples of LPFs are shown in Figure 17. When the active filter of Figure 17(c) is used, the reference should be applied to FIN-B because of the amplifier inversion. Also, in practical filter implementations, C2 is used as additional filtering at the VCO input. The value of C2 should be equal to or less than one tenth the value of C1.

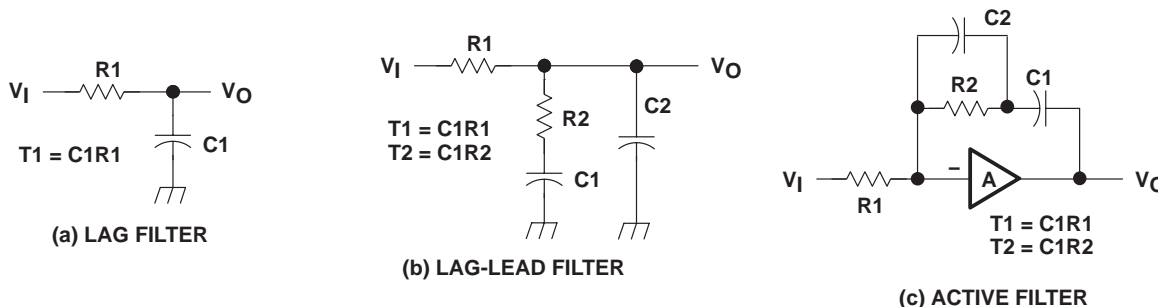

Figure 17. LPF Examples for PLL

the passive filter

The transfer function for the low-pass filter shown in Figure 17(b) is;

$$\frac{V_O}{V_{IN}} = \frac{1 + s \cdot T2}{1 + s \cdot (T1 + T2)} \tag{2}$$

where

$$T1 = R1 \cdot C1 \text{ and } T2 = R2 \cdot C1$$

Using this filter makes the closed-loop PLL system a type 1 second-order system. The response curves of this system to a unit step are shown in Figure 18.

the active filter

When using the active filter shown in Figure 17(c), the phase detector inputs must be reversed since the filter adds an additional inversion. Therefore, the input reference frequency should be applied to the FIN-B terminal and the output of the VCO divider should be applied to the input reference terminal, FIN-A.

The transfer function for the active filter shown in Figure 17(c) is:

$$F(s) = \frac{1 + s \cdot R2 \cdot C1}{s \cdot R1 \cdot C1} \tag{3}$$

Using this filter makes the closed-loop PLL system a type 2 second-order system. The response curves of this system to a unit step are shown in Figure 19.

APPLICATION INFORMATION

Using the lag-lead filter in Figure 17(b) and divider N value, the transfer function for phase and frequency are shown in equations 4 and 5. Note that the transfer function for phase differs from the transfer function for frequency by only the divider N value. The difference arises from the fact that the feedback for phase is unity while the feedback for frequency is 1/N.

Hence, the transfer function of Figure 17(a) for phase is

$$\frac{\Phi_2(s)}{\Phi_1(s)} = \frac{K_p \cdot K_V}{N \cdot (T_1 + T_2)} \left[\frac{1 + s \cdot T_2}{s^2 + s \left[1 + \frac{K_p \cdot K_V \cdot T_2}{N \cdot (T_1 + T_2)} \right] + \frac{K_p \cdot K_V}{N \cdot (T_1 + T_2)}} \right] \quad (4)$$

and the transfer function for frequency is

$$\frac{F_{OUT}(s)}{F_{REF}(s)} = \frac{K_p \cdot K_V}{(T_1 + T_2)} \left[\frac{1 + s \cdot T_2}{s^2 + s \cdot \left[1 + \frac{K_p \cdot K_V \cdot T_2}{N \cdot (T_1 + T_2)} \right] + \frac{K_p \cdot K_V}{N \cdot (T_1 + T_2)}} \right] \quad (5)$$

The standard 2-pole denominator is $D = s^2 + 2 \zeta \omega_n s + \omega_n^2$ and comparing the coefficients of the denominator of equation (4) and (5) with the standard 2-pole denominator gives the following results.

$$\omega_n = \sqrt{\frac{K_p \cdot K_V}{N \cdot (T_1 + T_2)}} \quad (6)$$

Solving for $T_1 + T_2$

$$T_1 + T_2 = \frac{K_p \cdot K_V}{N \cdot \omega_n^2}$$

and by using this value for $T_1 + T_2$ in equation (6) the damping factor is

$$\zeta = \frac{\omega_n}{2} \cdot \left(T_2 + \frac{N}{K_p \cdot K_V} \right) \quad (7)$$

solving for T_2

$$T_2 = \frac{2 \zeta}{\omega_n} - \frac{N}{K_p \cdot K_V} \quad (8)$$

then by substituting for T_2 in equation (6)

$$T_1 = \frac{K_V \cdot K_p}{N \cdot \omega_n^2} - \frac{2 \zeta}{\omega_n} + \frac{N}{K_p \cdot K_V} \quad (9)$$

TLC2933 HIGH-PERFORMANCE PHASE-LOCKED LOOP

SLAS136B – APRIL 1996 – REVISED JANUARY 2002

APPLICATION INFORMATION

From the circuit constants and the initial design parameters then

$$R2 = \left[\frac{2\zeta}{\omega_n} - \frac{N}{K_p \cdot K_V} \right] \frac{1}{C1} \quad (10)$$

$$R1 = \left[\frac{K_p \cdot K_V}{\omega_n^2 \cdot N} - \frac{2\zeta}{\omega_n} + \frac{N}{K_p \cdot K_V} \right] \frac{1}{C1} \quad (11)$$

The capacitor, C1, is usually chosen between 1 μ F and 0.1 μ F to allow for reasonable resistor values and physical capacitor size.

APPLICATION INFORMATION

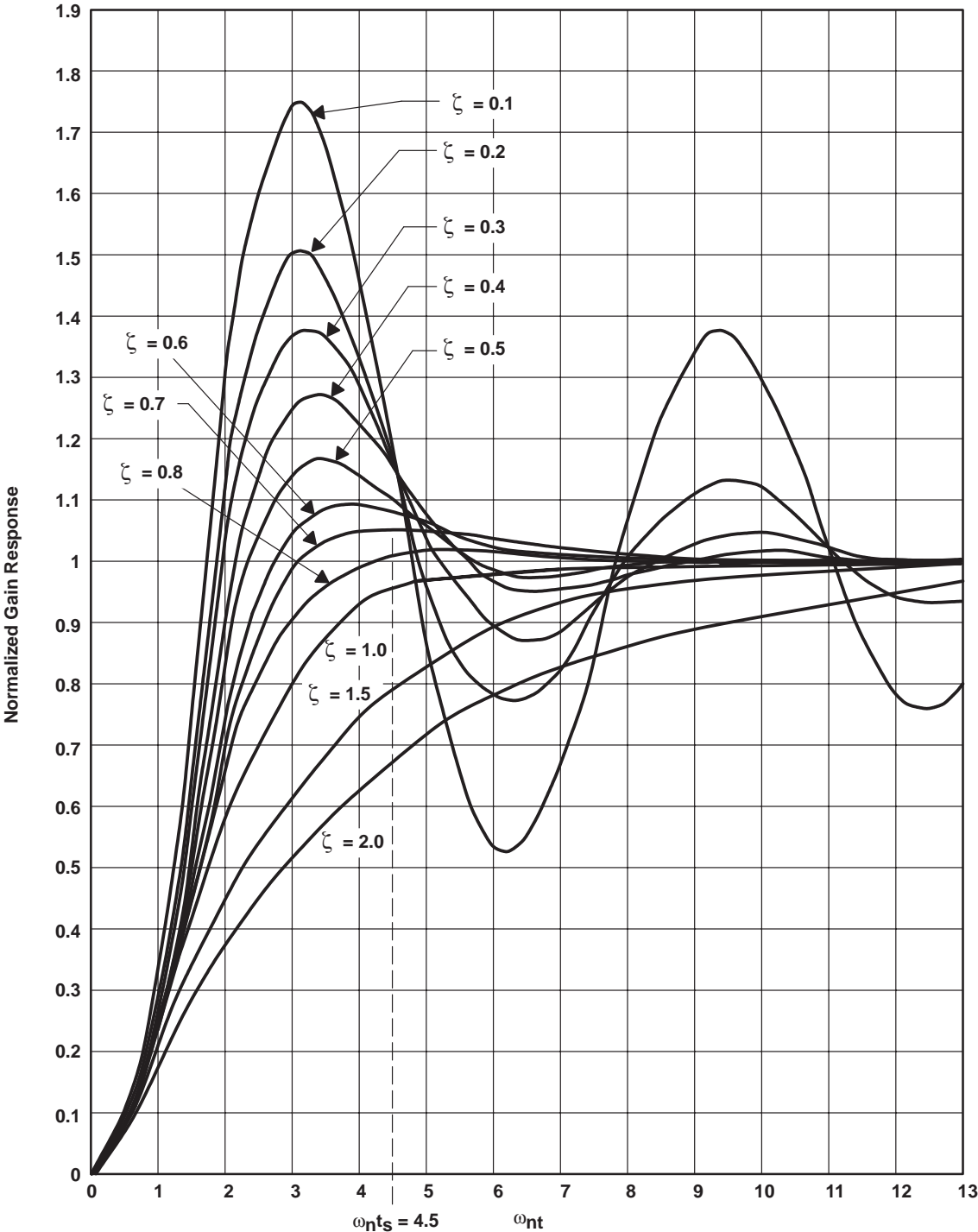

Figure 18. Type 1 Second-Order Step Response

TLC2933 HIGH-PERFORMANCE PHASE-LOCKED LOOP

SLAS136B – APRIL 1996 – REVISED JANUARY 2002

APPLICATION INFORMATION

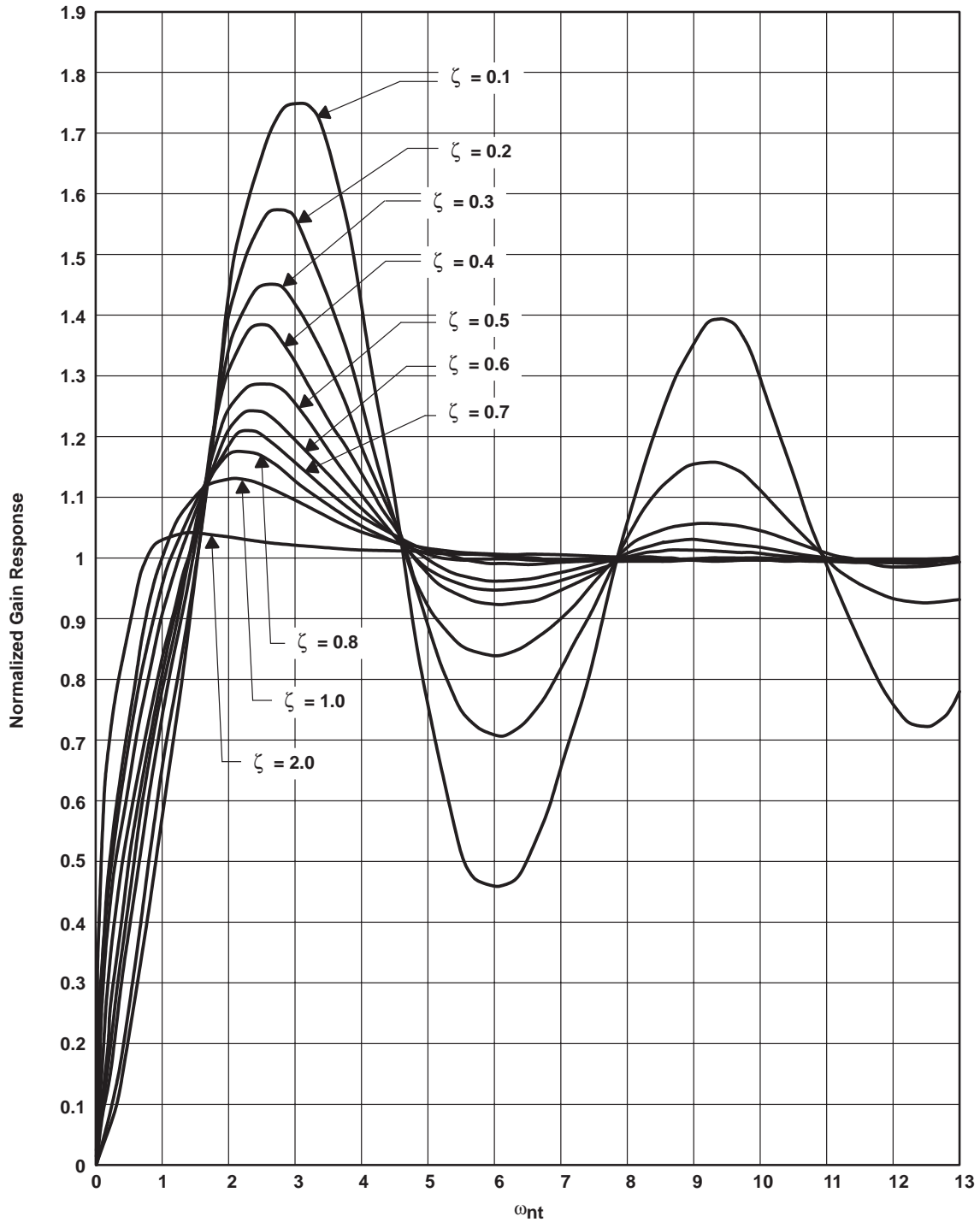

Figure 19. Type 2 Second-Order Step Response

APPLICATION INFORMATION

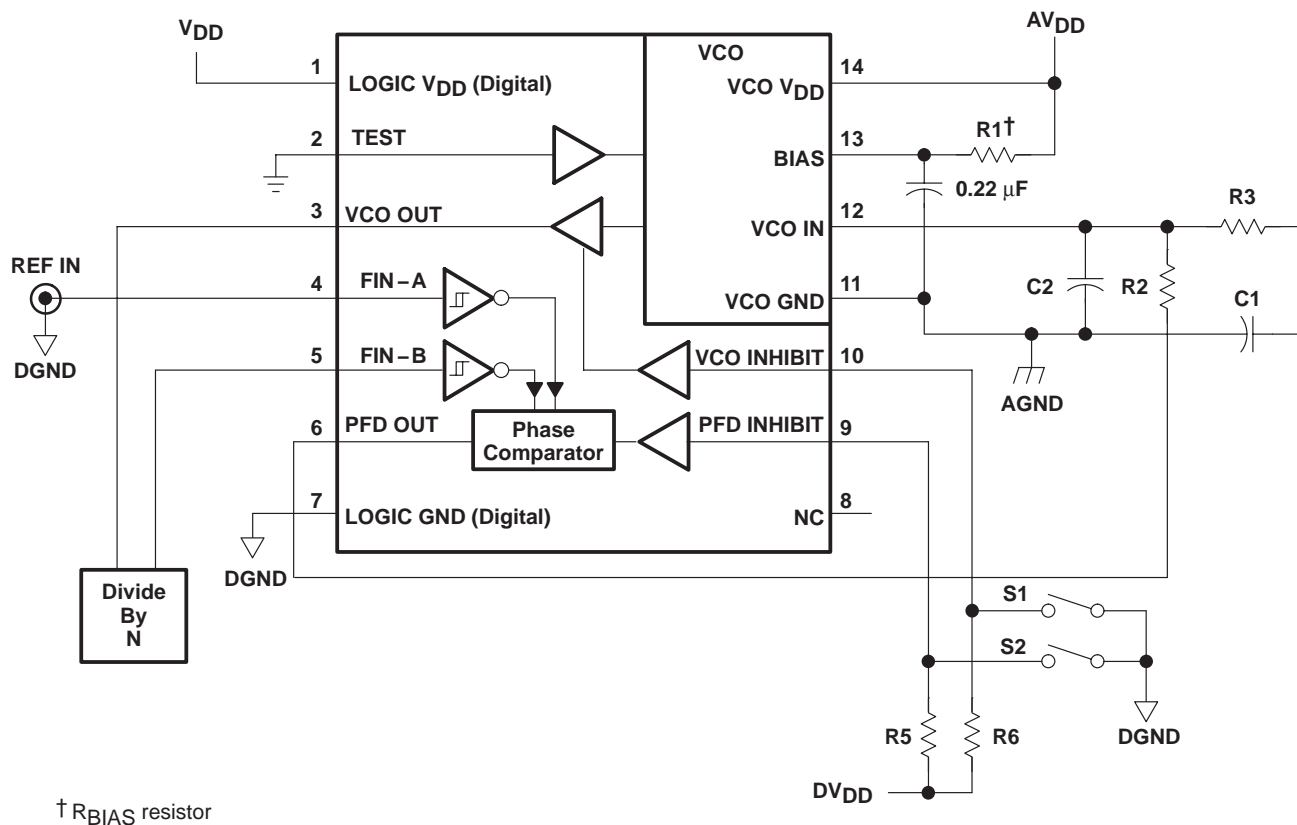

Figure 20. Evaluation and Operation Schematic

PCB layout considerations

The TLC2933 contains a high frequency oscillator; therefore, very careful breadboarding and PCB layout is required for evaluation.

The following design recommendations benefit the TLC2933 user:

- External analog and digital circuitry should be physically separated and shielded as much as possible to reduce system noise.
- Radio frequency (RF) breadboarding or RF PCB techniques should be used throughout the evaluation and production process.
- Wide ground leads or a ground plane should be used on the PCB layouts to minimize parasitic inductance and resistance. The ground plane is the better choice for noise reduction.
- LOGIC V_{DD} and VCO V_{DD} should be separate PCB traces and connected to the best filtered supply point available in the system to minimize supply cross-coupling.
- VCO V_{DD} to ground and LOGIC V_{DD} to ground should be decoupled with a 0.1-μF capacitor placed as close as possible to the appropriate device terminals.
- The no-connection (NC) terminal on the package should be connected to ground to prevent stray pickup.

PACKAGING INFORMATION

Orderable Device	Status (1)	Package Type	Package Drawing	Pins	Package Qty	Eco Plan (2)	Lead/Ball Finish (6)	MSL Peak Temp (3)	Op Temp (°C)	Device Marking (4/5)	Samples
TLC2933IPW	NRND	TSSOP	PW	14	90	Green (RoHS & no Sb/Br)	CU NIPDAU	Level-1-260C-UNLIM	-20 to 75	Y2933	
TLC2933IPWG4	NRND	TSSOP	PW	14	90	Green (RoHS & no Sb/Br)	CU NIPDAU	Level-1-260C-UNLIM	-20 to 75	Y2933	
TLC2933IPWR	NRND	TSSOP	PW	14	2000	Green (RoHS & no Sb/Br)	CU NIPDAU	Level-1-260C-UNLIM	-20 to 75	Y2933	
TLC2933IPWRG4	NRND	TSSOP	PW	14	2000	Green (RoHS & no Sb/Br)	CU NIPDAU	Level-1-260C-UNLIM	-20 to 75	Y2933	

(1) The marketing status values are defined as follows:

ACTIVE: Product device recommended for new designs.

LIFEBUY: TI has announced that the device will be discontinued, and a lifetime-buy period is in effect.

NRND: Not recommended for new designs. Device is in production to support existing customers, but TI does not recommend using this part in a new design.

PREVIEW: Device has been announced but is not in production. Samples may or may not be available.

OBSOLETE: TI has discontinued the production of the device.

(2) Eco Plan - The planned eco-friendly classification: Pb-Free (RoHS), Pb-Free (RoHS Exempt), or Green (RoHS & no Sb/Br) - please check <http://www.ti.com/productcontent> for the latest availability information and additional product content details.

TBD: The Pb-Free/Green conversion plan has not been defined.

Pb-Free (RoHS): TI's terms "Lead-Free" or "Pb-Free" mean semiconductor products that are compatible with the current RoHS requirements for all 6 substances, including the requirement that lead not exceed 0.1% by weight in homogeneous materials. Where designed to be soldered at high temperatures, TI Pb-Free products are suitable for use in specified lead-free processes.

Pb-Free (RoHS Exempt): This component has a RoHS exemption for either 1) lead-based flip-chip solder bumps used between the die and package, or 2) lead-based die adhesive used between the die and leadframe. The component is otherwise considered Pb-Free (RoHS compatible) as defined above.

Green (RoHS & no Sb/Br): TI defines "Green" to mean Pb-Free (RoHS compatible), and free of Bromine (Br) and Antimony (Sb) based flame retardants (Br or Sb do not exceed 0.1% by weight in homogeneous material)

(3) MSL, Peak Temp. - The Moisture Sensitivity Level rating according to the JEDEC industry standard classifications, and peak solder temperature.

(4) There may be additional marking, which relates to the logo, the lot trace code information, or the environmental category on the device.

(5) Multiple Device Markings will be inside parentheses. Only one Device Marking contained in parentheses and separated by a "~" will appear on a device. If a line is indented then it is a continuation of the previous line and the two combined represent the entire Device Marking for that device.

(6) Lead/Ball Finish - Orderable Devices may have multiple material finish options. Finish options are separated by a vertical ruled line. Lead/Ball Finish values may wrap to two lines if the finish value exceeds the maximum column width.

Important Information and Disclaimer: The information provided on this page represents TI's knowledge and belief as of the date that it is provided. TI bases its knowledge and belief on information provided by third parties, and makes no representation or warranty as to the accuracy of such information. Efforts are underway to better integrate information from third parties. TI has taken and continues to take reasonable steps to provide representative and accurate information but may not have conducted destructive testing or chemical analysis on incoming materials and chemicals. TI and TI suppliers consider certain information to be proprietary, and thus CAS numbers and other limited information may not be available for release.

In no event shall TI's liability arising out of such information exceed the total purchase price of the TI part(s) at issue in this document sold by TI to Customer on an annual basis.

TAPE AND REEL INFORMATION
REEL DIMENSIONS

TAPE DIMENSIONS

A0	Dimension designed to accommodate the component width
B0	Dimension designed to accommodate the component length
K0	Dimension designed to accommodate the component thickness
W	Overall width of the carrier tape
P1	Pitch between successive cavity centers

TAPE AND REEL INFORMATION

*All dimensions are nominal

Device	Package Type	Package Drawing	Pins	SPQ	Reel Diameter (mm)	Reel Width W1 (mm)	A0 (mm)	B0 (mm)	K0 (mm)	P1 (mm)	W (mm)	Pin1 Quadrant
TLC2933IPWR	TSSOP	PW	14	2000	330.0	12.4	6.9	5.6	1.6	8.0	12.0	Q1

TAPE AND REEL BOX DIMENSIONS

*All dimensions are nominal

Device	Package Type	Package Drawing	Pins	SPQ	Length (mm)	Width (mm)	Height (mm)
TLC2933IPWR	TSSOP	PW	14	2000	367.0	367.0	35.0

IMPORTANT NOTICE

Texas Instruments Incorporated (TI) reserves the right to make corrections, enhancements, improvements and other changes to its semiconductor products and services per JESD46, latest issue, and to discontinue any product or service per JESD48, latest issue. Buyers should obtain the latest relevant information before placing orders and should verify that such information is current and complete.

TI's published terms of sale for semiconductor products (<http://www.ti.com/sc/docs/stdterms.htm>) apply to the sale of packaged integrated circuit products that TI has qualified and released to market. Additional terms may apply to the use or sale of other types of TI products and services.

Reproduction of significant portions of TI information in TI data sheets is permissible only if reproduction is without alteration and is accompanied by all associated warranties, conditions, limitations, and notices. TI is not responsible or liable for such reproduced documentation. Information of third parties may be subject to additional restrictions. Resale of TI products or services with statements different from or beyond the parameters stated by TI for that product or service voids all express and any implied warranties for the associated TI product or service and is an unfair and deceptive business practice. TI is not responsible or liable for any such statements.

Buyers and others who are developing systems that incorporate TI products (collectively, "Designers") understand and agree that Designers remain responsible for using their independent analysis, evaluation and judgment in designing their applications and that Designers have full and exclusive responsibility to assure the safety of Designers' applications and compliance of their applications (and of all TI products used in or for Designers' applications) with all applicable regulations, laws and other applicable requirements. Designer represents that, with respect to their applications, Designer has all the necessary expertise to create and implement safeguards that (1) anticipate dangerous consequences of failures, (2) monitor failures and their consequences, and (3) lessen the likelihood of failures that might cause harm and take appropriate actions. Designer agrees that prior to using or distributing any applications that include TI products, Designer will thoroughly test such applications and the functionality of such TI products as used in such applications.

TI's provision of technical, application or other design advice, quality characterization, reliability data or other services or information, including, but not limited to, reference designs and materials relating to evaluation modules, (collectively, "TI Resources") are intended to assist designers who are developing applications that incorporate TI products; by downloading, accessing or using TI Resources in any way, Designer (individually or, if Designer is acting on behalf of a company, Designer's company) agrees to use any particular TI Resource solely for this purpose and subject to the terms of this Notice.

TI's provision of TI Resources does not expand or otherwise alter TI's applicable published warranties or warranty disclaimers for TI products, and no additional obligations or liabilities arise from TI providing such TI Resources. TI reserves the right to make corrections, enhancements, improvements and other changes to its TI Resources. TI has not conducted any testing other than that specifically described in the published documentation for a particular TI Resource.

Designer is authorized to use, copy and modify any individual TI Resource only in connection with the development of applications that include the TI product(s) identified in such TI Resource. NO OTHER LICENSE, EXPRESS OR IMPLIED, BY ESTOPPEL OR OTHERWISE TO ANY OTHER TI INTELLECTUAL PROPERTY RIGHT, AND NO LICENSE TO ANY TECHNOLOGY OR INTELLECTUAL PROPERTY RIGHT OF TI OR ANY THIRD PARTY IS GRANTED HEREIN, including but not limited to any patent right, copyright, mask work right, or other intellectual property right relating to any combination, machine, or process in which TI products or services are used. Information regarding or referencing third-party products or services does not constitute a license to use such products or services, or a warranty or endorsement thereof. Use of TI Resources may require a license from a third party under the patents or other intellectual property of the third party, or a license from TI under the patents or other intellectual property of TI.

TI RESOURCES ARE PROVIDED "AS IS" AND WITH ALL FAULTS. TI DISCLAIMS ALL OTHER WARRANTIES OR REPRESENTATIONS, EXPRESS OR IMPLIED, REGARDING RESOURCES OR USE THEREOF, INCLUDING BUT NOT LIMITED TO ACCURACY OR COMPLETENESS, TITLE, ANY EPIDEMIC FAILURE WARRANTY AND ANY IMPLIED WARRANTIES OF MERCHANTABILITY, FITNESS FOR A PARTICULAR PURPOSE, AND NON-INFRINGEMENT OF ANY THIRD PARTY INTELLECTUAL PROPERTY RIGHTS. TI SHALL NOT BE LIABLE FOR AND SHALL NOT DEFEND OR INDEMNIFY DESIGNER AGAINST ANY CLAIM, INCLUDING BUT NOT LIMITED TO ANY INFRINGEMENT CLAIM THAT RELATES TO OR IS BASED ON ANY COMBINATION OF PRODUCTS EVEN IF DESCRIBED IN TI RESOURCES OR OTHERWISE. IN NO EVENT SHALL TI BE LIABLE FOR ANY ACTUAL, DIRECT, SPECIAL, COLLATERAL, INDIRECT, PUNITIVE, INCIDENTAL, CONSEQUENTIAL OR EXEMPLARY DAMAGES IN CONNECTION WITH OR ARISING OUT OF TI RESOURCES OR USE THEREOF, AND REGARDLESS OF WHETHER TI HAS BEEN ADVISED OF THE POSSIBILITY OF SUCH DAMAGES.

Unless TI has explicitly designated an individual product as meeting the requirements of a particular industry standard (e.g., ISO/TS 16949 and ISO 26262), TI is not responsible for any failure to meet such industry standard requirements.

Where TI specifically promotes products as facilitating functional safety or as compliant with industry functional safety standards, such products are intended to help enable customers to design and create their own applications that meet applicable functional safety standards and requirements. Using products in an application does not by itself establish any safety features in the application. Designers must ensure compliance with safety-related requirements and standards applicable to their applications. Designer may not use any TI products in life-critical medical equipment unless authorized officers of the parties have executed a special contract specifically governing such use. Life-critical medical equipment is medical equipment where failure of such equipment would cause serious bodily injury or death (e.g., life support, pacemakers, defibrillators, heart pumps, neurostimulators, and implantables). Such equipment includes, without limitation, all medical devices identified by the U.S. Food and Drug Administration as Class III devices and equivalent classifications outside the U.S.

TI may expressly designate certain products as completing a particular qualification (e.g., Q100, Military Grade, or Enhanced Product). Designers agree that it has the necessary expertise to select the product with the appropriate qualification designation for their applications and that proper product selection is at Designers' own risk. Designers are solely responsible for compliance with all legal and regulatory requirements in connection with such selection.

Designer will fully indemnify TI and its representatives against any damages, costs, losses, and/or liabilities arising out of Designer's non-compliance with the terms and provisions of this Notice.

Looking for pricing, stock, or lifecycle information?

Click below to explore more details on WIN SOURCE:

 [View TLC2933IPWR on WIN SOURCE](#)

 [Texas Instruments](#) Information

Optimize Your Supply Chain with WIN SOURCE Solutions

-  Global Sourcing Solution
-  Obsolete Management
-  Cost Control Management
-  Shortage Management
-  Alternative Solution
-  Excess Inventory Management