



THE DATASHEET OF TLC2934IPWR



TLC2934 3.3 V 130 MHz VCO, PHASE FREQUENCY DETECTOR

SLAS306 – NOVEMBER 2000

- **Voltage-Controlled Oscillator (VCO)**
 - Ring Oscillator Using Only One External Biasing Resistor (R_{BIAS})
- **Recommended Lock Frequency**
 - 100 MHz to 130 MHz
 - ($V_{DD} = 3.3\text{ V} + 5\%$, $T_A = -20^\circ\text{C}$ to 75°C)
- **Phase-Frequency Detector (PFD)**
 - Includes a High-Speed Edge-Triggered Detector With Internal Charge Pump
- **Independent VCO, PFD Power-Down Mode**
- **Thin Small-Outline Package (14 Terminal)**
- **Compatible Pin Assignment to TLC2932, TLC2933**

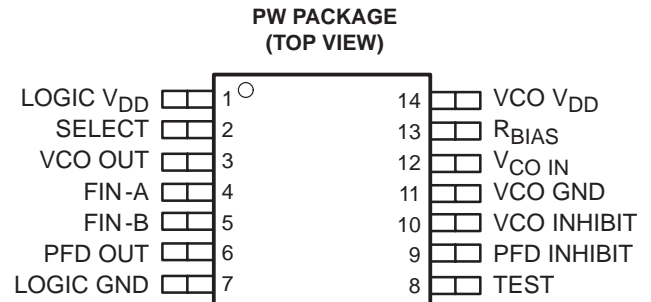

description

The TLC2934, a mixed signal IC designed for phase-locked-loop (PLL) systems, is composed of a voltage-controlled oscillator (VCO) and an edge-triggered-type phase frequency detector (PFD).

The internal VCO is based on the TLC2932 and TLC2933s ring oscillator. It oscillates in wider frequency with lower supply voltage, and it has stable oscillating performance. The oscillation function, provided by only one external resistor connection, supplies bias to the VCI internal circuit. Oscillator range is covered from 10 MHz to 130 MHz with a 3.3-V supply voltage. The VCO has an inhibit function to stop oscillation and for the power-down mode.

The internal PFD, a high-speed rising edge triggered type, has an internal charge pump with a high-impedance output buffer. The PFD detects phase difference between the reference frequency input and the signal frequency input from the VCO output through an external counter device. This functions the same as TLC2932 and TLC2933. The PFD also has the inhibit function for stop phase comparison and for power-down mode.

block diagram

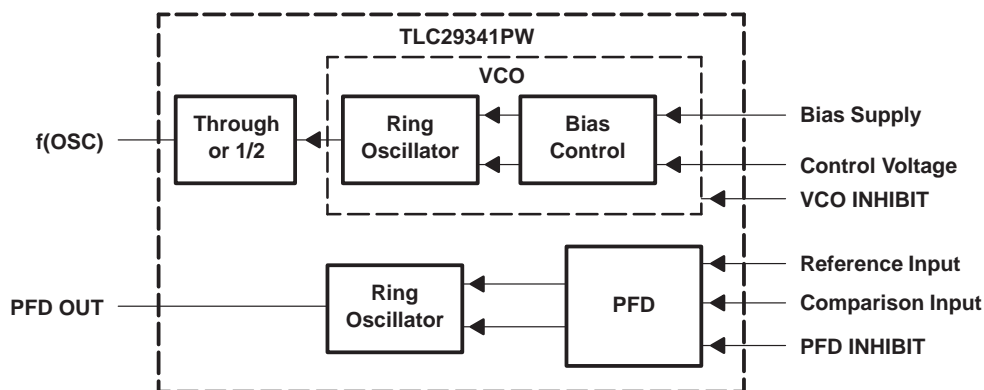

Please be aware that an important notice concerning availability, standard warranty, and use in critical applications of Texas Instruments semiconductor products and disclaimers thereto appears at the end of this data sheet.

PRODUCTION DATA information is current as of publication date. Products conform to specifications per the terms of Texas Instruments standard warranty. Production processing does not necessarily include testing of all parameters.

 **TEXAS
INSTRUMENTS**

POST OFFICE BOX 655303 • DALLAS, TEXAS 75265

Copyright © 2000, Texas Instruments Incorporated

TLC2934

3.3 V 130 MHz VCO, PHASE FREQUENCY DETECTOR

SLAS306 – NOVEMBER 2000

Terminal Functions

TERMINAL NAME	NO.	I/O	DESCRIPTION
FIN-A, FIN-B	4 5	I	Frequency signal inputs for PFD. The reference frequency signal (f_{REF-IN}) and the VCO output signal through the external counter device are applied to these terminals. When the LPF design is the lag-lead filter (passive filter and noninverting), f_{REF-IN} is input to FIN-A, and the VCO output signal is to FIN-B.
LOGIC GND	7		GND terminal for the internal logic circuit
LOGIC V_{DD}	1		Power supply terminal for the internal logic circuit. This power supply terminal separates from VCO V_{DD} to reduce cross-coupling between supplies.
PFD INHIBIT	9	I	PFD INHIBIT (power-down) control signal input terminal
PFD OUT	6	O	PFD output terminal. When PFD INHIBIT is high, PFD OUT is in the high-impedance state.
RBIAS	13	I	Bias resistor (R_{BIAS}) terminal. Connect a resistor between VCO GND and this terminal to supply bias to internal VCO circuit. TLC2934 bias resistor connection is different from TLC2932 and TLC2933, where bias resistor R_{BIAS} is connected to VCO V_{DD} .
SELECT	2	I	1/2 divider select terminal. L=through output, H=1/2 output.
TEST	8		Test terminal. Use for production test. Tie to GND when in normal use.
VCO GND	11		GND terminal for internal VCO
VCO OUT	3	O	VCO output terminal. When VCO INHIBIT = high, VCO OUT is low.
VCO INHIBIT	10	I	VCO INHIBIT (power-down) control signal input terminal
VCO IN	12	I	VCO control voltage input terminal. Normally, The external LPF is connected to this terminal.
VCO V_{DD}	14		Power supply terminal for the internal VCO circuit. This power supply terminal should be separate from LOGIC V_{DD} to reduce cross-coupling between supplies.

absolute maximum ratings over operating free-air temperature (unless otherwise noted)†

Supply voltage (each supply), V_{DD} (see Note 1)	–0.5 V to 4 V
Input voltage range (each input), V_I (see Note 1)	–0.5 V to $V_{DD} + 0.5$ V
Input current (each input), I_I	± 20 mA
Output current (each output), I_O	± 20 mA
Continuous total power dissipation at (or below) $T_A = 25^\circ\text{C}$ (see Note 2), P_D	700 mW
Operating free-air temperature range, T_A	–20°C to 75°C
Storage temperature range, T_{stg}	–65°C to 150°C
Lead temperature 1,6 mm (1/16 inch) from case for 10 seconds	260°C

† Stresses beyond those listed under “absolute maximum ratings” may cause permanent damage to the device. These are stress ratings only, and functional operation of the device at these or any other conditions beyond those indicated under “recommended operating conditions” is not implied. Exposure to absolute-maximum-rated conditions for extended periods may affect device reliability.

- NOTES: 1. All voltage values are with respect to network ground terminal.
2. For operation above 25°C free-air temperature, derate linearly at the rate of 5.6 mW/°C



TLC2934

3.3 V 130 MHz VCO, PHASE FREQUENCY DETECTOR

SLAS306 – NOVEMBER 2000

recommended operating conditions

		MIN	TYP	MAX	UNIT
Supply voltage (each supply, V_{DD} (see Notes 3 and 4))		3.15	3.3	3.45	V
Input voltage (each input except for $V_{CO\ IN}$, V_I)		0		V_{DD}	V
Output current (each output), I_O		0		± 2	mA
VCO control voltage, $V_{CO\ IN}$		0.5		V_{DD}	V
Lock frequency (through output)	$R_{BIAS} = 1\text{ k}\Omega$	36		130	MHz
	$R_{BIAS} = 1.8\text{ k}\Omega$	28		90	
	$R_{BIAS} = 2.4\text{ k}\Omega$	26		80	
	$R_{BIAS} = 3.3\text{ k}\Omega$	20		60	
Lock frequency (1/2 output)	$R_{BIAS} = 1\text{ k}\Omega$	18		65	MHz
	$R_{BIAS} = 1.8\text{ k}\Omega$	14		45	
	$R_{BIAS} = 2.4\text{ k}\Omega$	13		40	
	$R_{BIAS} = 3.3\text{ k}\Omega$	10		30	
Bias resistor, R_{BIAS}		1.0		3.3	$\text{K}\Omega$
Operating temperature range, T_A		-20		75	$^{\circ}\text{C}$
$V_{CO\ IN}$ voltage at $V_{CO\ INHIBIT\downarrow}$, $V_{(CINH)}$ (see Note 5)			0	0.5	V

- NOTES: 3. It is recommended that the logic supply terminal (LOGIC V_{DD}) and the VCO supply terminal (VCO V_{DD}) be at the same voltage and separated from each other.
4. A bypass capacitor is placed as close as possible to each supply terminal.
5. For stable restart of VCO, $V_{CO\ IN}$ is 0 V when VCO INHIBIT is pulled down to GND level to disable the VCO INHIBIT function. And also, $V_{CO\ IN}$ should be 0 V when the operation will be started by supplying the power.

electrical characteristics over recommended operating free-air temperature range, $V_{DD}=3.3\text{ V}$ (unless otherwise noted)

VCO

PARAMETER		TEST CONDITIONS	MIN	TYP	MAX	UNIT
V_{OH}	High-level output voltage	$I_{OH} = -2\text{ mA}$	3.1			V
V_{OL}	Low-level output voltage	$I_{OL} = 2\text{ mA}$			0.2	V
V_{IH}	High-level input voltage	Logic signal input	2.3			V
V_{IL}	Low-level input voltage	Logic signal input			1.0	V
I_I	Input current at TEST, VCO INHIBIT	$V_I = V_{DD}$ or GND			± 1	μA
$Z_{V(CO\ IN)}$	Input impedance at $V_{CO\ IN}$	$V_{CO\ IN} = 1/2 V_{DD}$		10		$\text{M}\Omega$
$I_{DD(INH)}$	VCO supply current (inhibit)	See Note 6		0.01	1	μA
$I_{DD(VCO)}$	VCO supply current	See Note 7		10	15	mA

- NOTES: 6. Current into VCO V_{DD} , when VCO INHIBIT = V_{DD} , PFD is inhibited.
7. Current into VCO V_{DD} , when $V_{CO\ IN} = 1/2 V_{DD}$, $R_{BIAS} = 1\text{ k}\Omega$, VCO INHIBIT = GND, PFD is inhibited.

TLC2934

3.3 V 130 MHz VCO, PHASE FREQUENCY DETECTOR

SLAS306 – NOVEMBER 2000

electrical characteristics over recommended operating free-air temperature range, $V_{DD}=3.3$ V (unless otherwise noted) (continued)

VCO

PARAMETER		TEST CONDITIONS	MIN	TYP	MAX	UNIT
V_{OH}	High-level output voltage	$I_{OH} = -2$ mA	3.1			V
V_{OL}	Low-level output voltage	$I_{OL} = 2$ mA			0.2	V
I_{OZ}	High-impedance state output current	PFD INHIBIT = high, $V_O = V_{DD}$ or GND			± 1	μ A
V_{IH}	High-level input voltage at FIN-A,B		2.3			V
V_{IL}	Low-level input voltage at FIN-A,B				1.0	V
$V_{(TO)}$	Positive input threshold voltage at PFD INHIBIT		1.0	1.65	2.3	V
C_I	Input capacitance at FIN-A,B			5		pF
$Z_{(IN)}$	Input impedance at FIN-A,B			10		M Ω
$I_{DD(PFD)}$	PFD supply current	See Note 8		1.5	6.0	mA

NOTE 8: Current into LOGIC V_{DD} , when FIN-A, FIN-B=50 MHz ($V_{I(pp)} = 3.3$ V, rectangular wave), Test=GND, no load, and VCO OUT is inhibited.

VCO

PARAMETER		TEST CONDITIONS	MIN	TYP	MAX	UNIT
$f_{(OSC)}$	Operating oscillation frequency	RBIAS = 1 k Ω	67	90	113	MHz
$t_{(STB)}$	Time to stable oscillation	See Note 9		0.7	10	μ s
t_r	Rise time	$C_L = 15$ pF, See Figure 3		1.7	5	ns
t_f	Fall time	$C_L = 15$ pF, See Figure 3		1.1	4	ns
$f_{(duty)}$	Duty cycle at VCO OUT	RBIAS = 1.0 k Ω , $V_{CO IN} = 1/2 V_{DD}$	45%	50%	55%	
	Temperature coefficient of oscillation frequency	RBIAS=1.0k Ω , $V_{CO IN} = 1/2 V_{DD}$, $T_A = -20^\circ$ C to 75° C		0.03		%/ $^\circ$ C
	Supply voltage coefficient of oscillation frequency	RBIAS = 1 k Ω , $V_{CO IN} = 1.65$ V, $V_{DD} = 3.15$ V to 3.45 V		0.02		%/mV
	Jitter absolute	RBIAS = 1 k Ω , $V_{CO IN} = 1/2 V_{DD}$		50		ps

NOTE 9: Current into VCO V_{DD} , when VCO INHIBIT = V_{DD} , PFD is inhibited.

PFD AC

PARAMETER		TEST CONDITIONS	MIN	TYP	MAX	UNIT
f_{MAX}	Maximum operating frequency		50			MHz
t_{PLZ}	PFD output disable time from low level	See Figures 4 and 5 and Table 6		15.3	40	ns
t_{PHZ}	PFD output disable time from high level			15.5	40	ns
t_{PZL}	PFD output enable time from low level			2.4	10	ns
t_{PZH}	PFD output enable time from high level			2.5	10	ns
t_r	Rise time	$C_L=15$ pF (see Figure 3)		1.2	5	ns
t_f	Fall time	$C_L=15$ pF (see Figure 3)		0.7	5	ns



PARAMETER MEASUREMENT INFORMATION

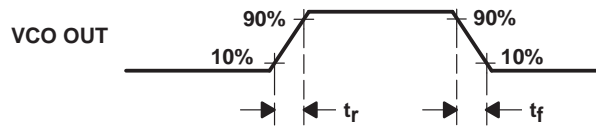
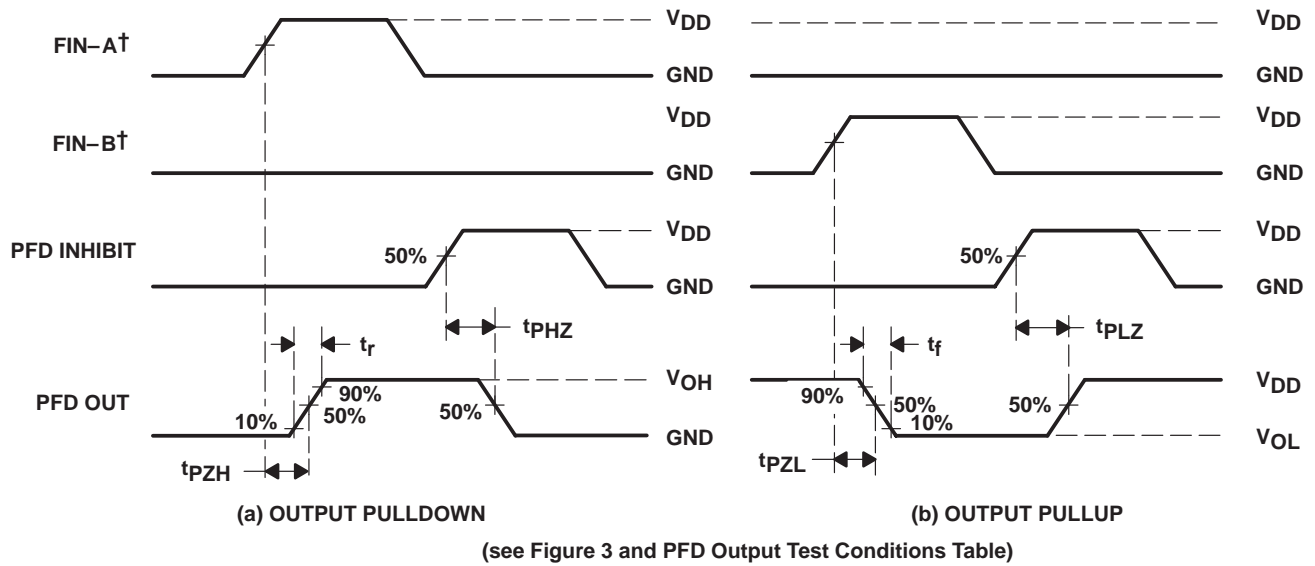

Figure 1. VCO Output Voltage Waveform



† FIN-A and FIN-B are for reference phase only, not for timing.

Figure 2. PFD Output Voltage Waveform

PFD Output Test Conditions

PARAMETER	R_L	C_L	S_L	S_2
t_{PZH}	1 k Ω	15 pF	Open	Close
t_{PHZ}				
t_r			Close	Open
t_{PZL}				
t_{PLZ}				
t_f				

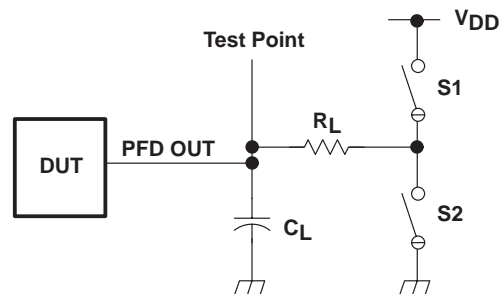

Figure 3. PFD Output Test Condition

TLC2934

3.3 V 130 MHz VCO, PHASE FREQUENCY DETECTOR

SLAS306 – NOVEMBER 2000

TYPICAL CHARACTERISTICS

VCO OSCILLATION FREQUENCY
vs
VCO CONTROL VOLTAGE

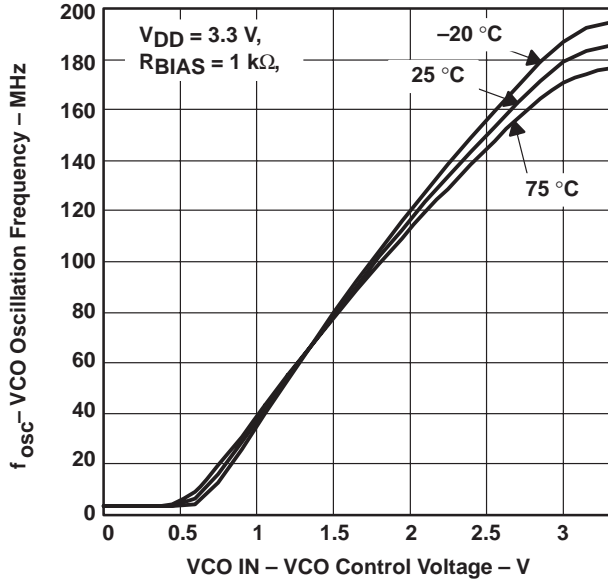

Figure 4

VCO OSCILLATION FREQUENCY
vs
VCO CONTROL VOLTAGE

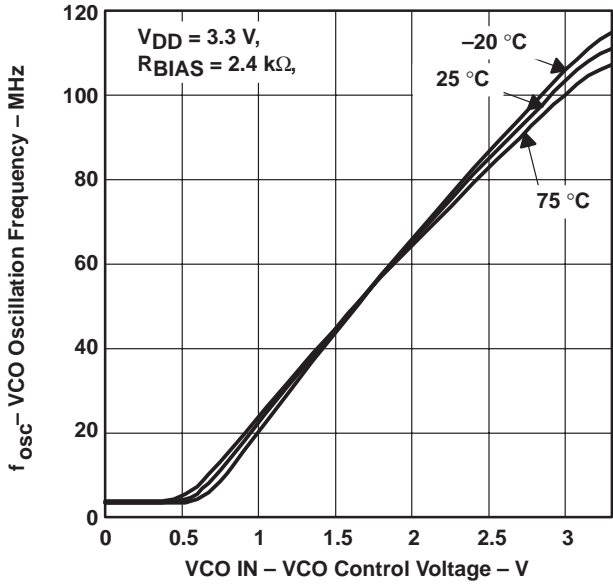

Figure 5

VCO OSCILLATION FREQUENCY
vs
VCO CONTROL VOLTAGE

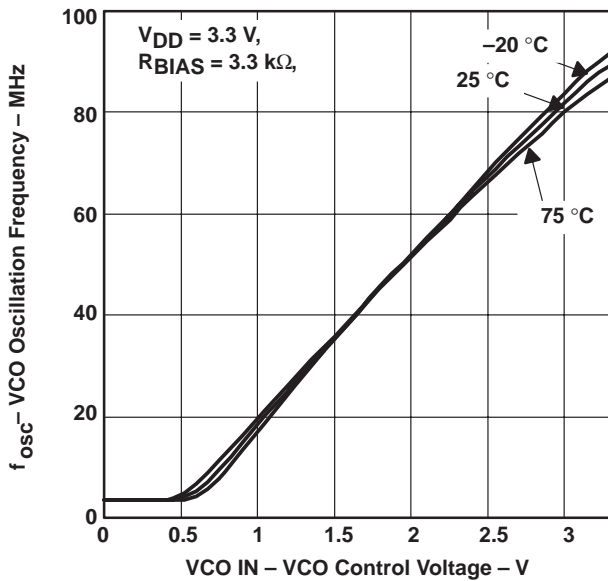

Figure 6

VCO OSCILLATION FREQUENCY
vs
VCO SUPPLY VOLTAGE

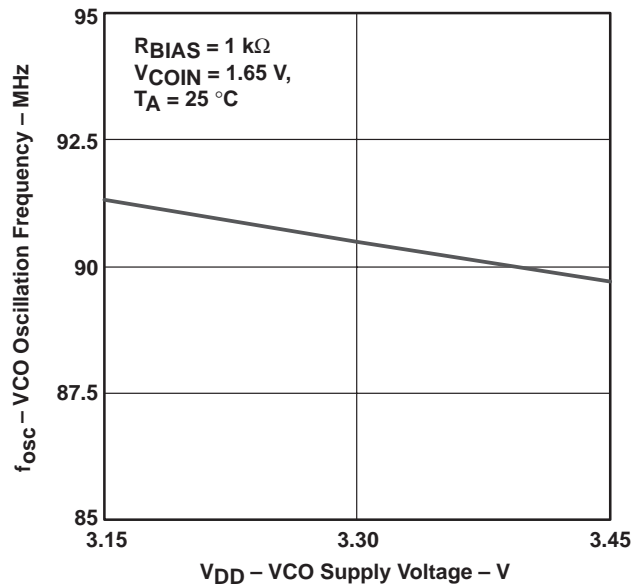

Figure 7

PACKAGING INFORMATION

Orderable Device	Status ⁽¹⁾	Package Type	Package Drawing	Pins	Package Qty	Eco Plan ⁽²⁾	Lead/ Ball Finish	MSL Peak Temp ⁽³⁾	Samples (Requires Login)
TLC2934IPW	NRND	TSSOP	PW	14	90	Green (RoHS & no Sb/Br)	CU NIPDAU	Level-1-260C-UNLIM	
TLC2934IPWG4	NRND	TSSOP	PW	14	90	Green (RoHS & no Sb/Br)	CU NIPDAU	Level-1-260C-UNLIM	
TLC2934IPWR	NRND	TSSOP	PW	14	2000	Green (RoHS & no Sb/Br)	CU NIPDAU	Level-1-260C-UNLIM	

⁽¹⁾ The marketing status values are defined as follows:

ACTIVE: Product device recommended for new designs.

LIFEBUY: TI has announced that the device will be discontinued, and a lifetime-buy period is in effect.

NRND: Not recommended for new designs. Device is in production to support existing customers, but TI does not recommend using this part in a new design.

PREVIEW: Device has been announced but is not in production. Samples may or may not be available.

OBSOLETE: TI has discontinued the production of the device.

⁽²⁾ Eco Plan - The planned eco-friendly classification: Pb-Free (RoHS), Pb-Free (RoHS Exempt), or Green (RoHS & no Sb/Br) - please check <http://www.ti.com/productcontent> for the latest availability information and additional product content details.

TBD: The Pb-Free/Green conversion plan has not been defined.

Pb-Free (RoHS): TI's terms "Lead-Free" or "Pb-Free" mean semiconductor products that are compatible with the current RoHS requirements for all 6 substances, including the requirement that lead not exceed 0.1% by weight in homogeneous materials. Where designed to be soldered at high temperatures, TI Pb-Free products are suitable for use in specified lead-free processes.

Pb-Free (RoHS Exempt): This component has a RoHS exemption for either 1) lead-based flip-chip solder bumps used between the die and package, or 2) lead-based die adhesive used between the die and leadframe. The component is otherwise considered Pb-Free (RoHS compatible) as defined above.

Green (RoHS & no Sb/Br): TI defines "Green" to mean Pb-Free (RoHS compatible), and free of Bromine (Br) and Antimony (Sb) based flame retardants (Br or Sb do not exceed 0.1% by weight in homogeneous material)

⁽³⁾ MSL, Peak Temp. -- The Moisture Sensitivity Level rating according to the JEDEC industry standard classifications, and peak solder temperature.

Important Information and Disclaimer: The information provided on this page represents TI's knowledge and belief as of the date that it is provided. TI bases its knowledge and belief on information provided by third parties, and makes no representation or warranty as to the accuracy of such information. Efforts are underway to better integrate information from third parties. TI has taken and continues to take reasonable steps to provide representative and accurate information but may not have conducted destructive testing or chemical analysis on incoming materials and chemicals. TI and TI suppliers consider certain information to be proprietary, and thus CAS numbers and other limited information may not be available for release.

In no event shall TI's liability arising out of such information exceed the total purchase price of the TI part(s) at issue in this document sold by TI to Customer on an annual basis.

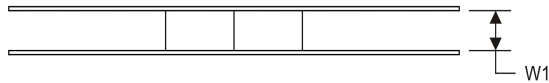
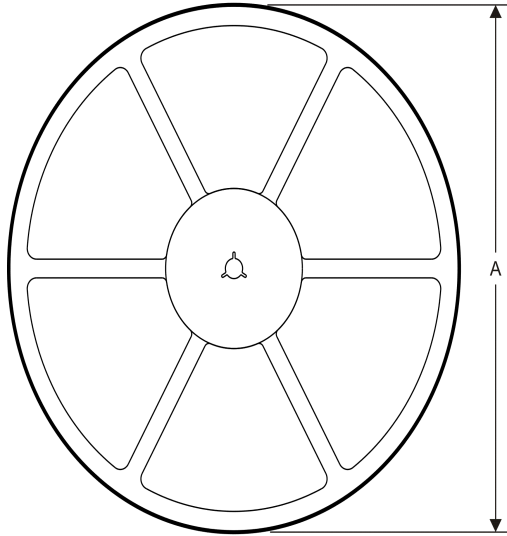
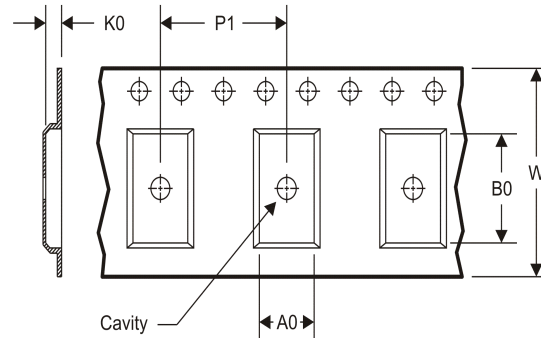
TAPE AND REEL INFORMATION
REEL DIMENSIONS

TAPE DIMENSIONS

A0	Dimension designed to accommodate the component width
B0	Dimension designed to accommodate the component length
K0	Dimension designed to accommodate the component thickness
W	Overall width of the carrier tape
P1	Pitch between successive cavity centers

TAPE AND REEL INFORMATION

*All dimensions are nominal

Device	Package Type	Package Drawing	Pins	SPQ	Reel Diameter (mm)	Reel Width W1 (mm)	A0 (mm)	B0 (mm)	K0 (mm)	P1 (mm)	W (mm)	Pin1 Quadrant
TLC2934IPWR	TSSOP	PW	14	2000	330.0	12.4	6.9	5.6	1.6	8.0	12.0	Q1

TAPE AND REEL BOX DIMENSIONS

*All dimensions are nominal

Device	Package Type	Package Drawing	Pins	SPQ	Length (mm)	Width (mm)	Height (mm)
TLC2934IPWR	TSSOP	PW	14	2000	367.0	367.0	35.0

IMPORTANT NOTICE

Texas Instruments Incorporated and its subsidiaries (TI) reserve the right to make corrections, enhancements, improvements and other changes to its semiconductor products and services per JESD46C and to discontinue any product or service per JESD48B. Buyers should obtain the latest relevant information before placing orders and should verify that such information is current and complete. All semiconductor products (also referred to herein as "components") are sold subject to TI's terms and conditions of sale supplied at the time of order acknowledgment.

TI warrants performance of its components to the specifications applicable at the time of sale, in accordance with the warranty in TI's terms and conditions of sale of semiconductor products. Testing and other quality control techniques are used to the extent TI deems necessary to support this warranty. Except where mandated by applicable law, testing of all parameters of each component is not necessarily performed.

TI assumes no liability for applications assistance or the design of Buyers' products. Buyers are responsible for their products and applications using TI components. To minimize the risks associated with Buyers' products and applications, Buyers should provide adequate design and operating safeguards.

TI does not warrant or represent that any license, either express or implied, is granted under any patent right, copyright, mask work right, or other intellectual property right relating to any combination, machine, or process in which TI components or services are used. Information published by TI regarding third-party products or services does not constitute a license to use such products or services or a warranty or endorsement thereof. Use of such information may require a license from a third party under the patents or other intellectual property of the third party, or a license from TI under the patents or other intellectual property of TI.

Reproduction of significant portions of TI information in TI data books or data sheets is permissible only if reproduction is without alteration and is accompanied by all associated warranties, conditions, limitations, and notices. TI is not responsible or liable for such altered documentation. Information of third parties may be subject to additional restrictions.

Resale of TI components or services with statements different from or beyond the parameters stated by TI for that component or service voids all express and any implied warranties for the associated TI component or service and is an unfair and deceptive business practice. TI is not responsible or liable for any such statements.

Buyer acknowledges and agrees that it is solely responsible for compliance with all legal, regulatory and safety-related requirements concerning its products, and any use of TI components in its applications, notwithstanding any applications-related information or support that may be provided by TI. Buyer represents and agrees that it has all the necessary expertise to create and implement safeguards which anticipate dangerous consequences of failures, monitor failures and their consequences, lessen the likelihood of failures that might cause harm and take appropriate remedial actions. Buyer will fully indemnify TI and its representatives against any damages arising out of the use of any TI components in safety-critical applications.

In some cases, TI components may be promoted specifically to facilitate safety-related applications. With such components, TI's goal is to help enable customers to design and create their own end-product solutions that meet applicable functional safety standards and requirements. Nonetheless, such components are subject to these terms.

No TI components are authorized for use in FDA Class III (or similar life-critical medical equipment) unless authorized officers of the parties have executed a special agreement specifically governing such use.

Only those TI components which TI has specifically designated as military grade or "enhanced plastic" are designed and intended for use in military/aerospace applications or environments. Buyer acknowledges and agrees that any military or aerospace use of TI components which have **not** been so designated is solely at the Buyer's risk, and that Buyer is solely responsible for compliance with all legal and regulatory requirements in connection with such use.

TI has specifically designated certain components which meet ISO/TS16949 requirements, mainly for automotive use. Components which have not been so designated are neither designed nor intended for automotive use; and TI will not be responsible for any failure of such components to meet such requirements.

Products

Audio	www.ti.com/audio
Amplifiers	amplifier.ti.com
Data Converters	dataconverter.ti.com
DLP® Products	www.dlp.com
DSP	dsp.ti.com
Clocks and Timers	www.ti.com/clocks
Interface	interface.ti.com
Logic	logic.ti.com
Power Mgmt	power.ti.com
Microcontrollers	microcontroller.ti.com
RFID	www.ti-rfid.com
OMAP Mobile Processors	www.ti.com/omap
Wireless Connectivity	www.ti.com/wirelessconnectivity

Applications

Automotive and Transportation	www.ti.com/automotive
Communications and Telecom	www.ti.com/communications
Computers and Peripherals	www.ti.com/computers
Consumer Electronics	www.ti.com/consumer-apps
Energy and Lighting	www.ti.com/energy
Industrial	www.ti.com/industrial
Medical	www.ti.com/medical
Security	www.ti.com/security
Space, Avionics and Defense	www.ti.com/space-avionics-defense
Video and Imaging	www.ti.com/video

TI E2E Community e2e.ti.com

Looking for pricing, stock, or lifecycle information?

Click below to explore more details on WIN SOURCE:

 [View TLC2934IPWR on WIN SOURCE](#)

 [Texas Instruments](#) Information

Optimize Your Supply Chain with WIN SOURCE Solutions

-  Global Sourcing Solution
-  Obsolete Management
-  Cost Control Management
-  Shortage Management
-  Alternative Solution
-  Excess Inventory Management