



## Micropower Supply Voltage Supervisors

 Check for Samples: [TLC7701](#), [TLC7725](#), [TLC7703](#), [TLC7733](#), [TLC7705](#)

### FEATURES

- Power-On Reset Generator
- Automatic Reset Generation After Voltage Drop
- Precision Voltage Sensor
- Temperature-Compensated Voltage Reference
- Programmable Delay Time by External Capacitor
- Supply Voltage Range . . . 2 V to 6 V
- Defined RESET Output from  $V_{DD} \geq 1$  V
- Power-Down Control Support for Static RAM With Battery Backup
- Maximum Supply Current of 16  $\mu$ A
- Power Saving Totem-Pole Outputs
- Temperature Range . . . Up to  $-55^{\circ}\text{C}$  to  $125^{\circ}\text{C}$

### APPLICATIONS

- Medical Imaging

### DESCRIPTION

The TLC77xx family of micropower supply voltage supervisors provide reset control, primarily in microcomputer and microprocessor systems.

During power-on,  $\overline{\text{RESET}}$  is asserted when  $V_{DD}$  reaches 1 V. After minimum  $V_{DD}$  ( $\geq 2$  V) is established, the circuit monitors SENSE voltage and keeps the reset outputs active as long as SENSE voltage ( $V_{I(\text{SENSE})}$ ) remains below the threshold voltage. An internal timer delays return of the output to the inactive state to ensure proper system reset. The delay time,  $t_d$ , is determined by an external capacitor:

$$t_d = 2.1 \times 10^4 \times C_T$$

Where

$C_T$  is in farads

$t_d$  is in seconds

Except for the TLC7701, which can be customized with two external resistors, each supervisor has a fixed sense threshold voltage set by an internal voltage divider. When SENSE voltage drops below the threshold voltage, the outputs become active and stay in that state until SENSE voltage returns above threshold voltage and the delay time,  $t_d$ , has expired.

DRB PACKAGE  
(TOP VIEW)



D, JG, P OR PW PACKAGE  
(TOP VIEW)



U PACKAGE  
(TOP VIEW)



FK PACKAGE  
(TOP VIEW)

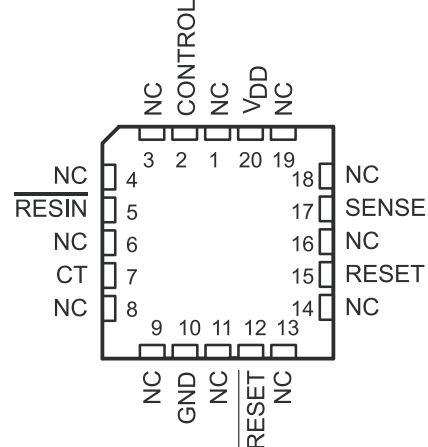

Please be aware that an important notice concerning availability, standard warranty, and use in critical applications of Texas Instruments semiconductor products and disclaimers thereto appears at the end of this data sheet.



These devices have limited built-in ESD protection. The leads should be shorted together or the device placed in conductive foam during storage or handling to prevent electrostatic damage to the MOS gates.

## DESCRIPTION (CONTINUED)

In addition to the power-on-reset and undervoltage-supervisor function, the TLC77xx adds power-down control support for static RAM. When CONTROL is tied to GND, RESET will act as active high. The voltage monitor contains additional logic intended for control of static memories with battery backup during power failure. By driving the chip select ( $\overline{CS}$ ) of the memory circuit with the RESET output of the TLC77xx and with the CONTROL driven by the memory bank select signal ( $\overline{CSH1}$ ) of the microprocessor (see Figure 10), the memory circuit is automatically disabled during a power loss. (In this application the TLC77xx power has to be supplied by the battery.)

The TLC77xxL is characterized for operation over a temperature range of  $-40^{\circ}\text{C}$  to  $85^{\circ}\text{C}$ ; the TLC77xxQ is characterized for operation over a temperature range of  $-40^{\circ}\text{C}$  to  $125^{\circ}\text{C}$ ; and the TLC77xxM is characterized for operation over the full Military temperature range of  $-55^{\circ}\text{C}$  to  $125^{\circ}\text{C}$ .

The 3x3 mm DRB package is also available as a non-magnetic package for medical imaging application.

## AVAILABLE OPTIONS

$T_A$	THRESHOLD VOLTAGE (V)	PACKAGED DEVICES						
		SMALL OUTLINE (D) <sup>(1)</sup>	CHIP CARRIER (FK)	CERAMIC DIP (JG)	CERAMIC DUAL FLATPACK (U)	PLASTIC DIP (P)	THIN SHRINK SMALL OUTLINE (PW) <sup>(2)</sup>	SMALL OUTLINE NO LEAD (DRB)
$-40^{\circ}\text{C}$ to $85^{\circ}\text{C}$	1.1	TCLC7701ID	—	—	—	TCLC7701IP	TCLC7701IPWR	—
	2.25	TLC7725ID	—	—	—	TLC7725IP	TLC7725IPWR	—
	2.63	TLC7703ID	—	—	—	TLC7703IP	TLC7703IPWR	—
	2.93	TLC7733ID	—	—	—	TLC7733IP	TLC7733IPWR	—
	4.55	TLC7705ID	—	—	—	TLC7705IP	TLC7705IPWR	—
	1.1	TLC7701IDBR	—	—	—	—	—	TLC7701IDRBT-NM
$-40^{\circ}\text{C}$ to $125^{\circ}\text{C}$	1.1	TLC7701QD	—	—	—	TLC7701QP	TLC7701QPWR	—
	2.25	TLC7725QD	—	—	—	TLC7725QP	TLC7725QPWR	—
	2.63	TLC7703QD	—	—	—	TLC7703QP	TLC7703QPWR	—
	2.93	TLC7733QD	—	—	—	TLC7733QP	TLC7733QPWR	—
	4.55	TLC7705QD	—	—	—	TLC7705QP	TLC7705QPWR	—
$-55^{\circ}\text{C}$ to $125^{\circ}\text{C}$	2.93	—	—	—	—	—	—	—
	4.55	—	—	—	—	—	—	—

(1) The D package is available taped and reeled. Add the suffix R to the device type when ordering (e.g., TLC7705QDR).

(2) The PW package is only available left-end taped and reeled (indicated by the R suffix on the device type; e.g., TLC7705QPWR).

Table 1. FUNCTION TABLE

CONTROL	$\overline{RESIN}$	$V_{I(SENSE)} > V_{IT+}$	$\overline{RESET}$	RESET
L	L	False	H	L
L	L	True	H	L
L	H	False	H	L
L	H	True	L <sup>(1)</sup>	H <sup>(1)</sup>
H	L	False	H	L
H	L	True	H	L
H	H	False	H	L
H	H	True	H	H <sup>(1)</sup>

(1) RESET and  $\overline{RESET}$  states shown are valid for  $t > t_d$ .

**LOGIC SYMBOL**



(1) This symbol is in accordance with ANSI/IEEE Std 91-1984 and IEC Publication 617-12.

FUNCTIONAL BLOCK DIAGRAM



† Outputs are totem-pole configuration. External pullup or pulldown resistors are not required.

‡ Nominal values:

	R1 (Typ)	R2 (Typ)
TLC7701	0	$\infty$
TLC7725	600 k $\Omega$	600 k $\Omega$
TLC7703	698 k $\Omega$	502 k $\Omega$
TLC7733	750 k $\Omega$	450 k $\Omega$
TLC7705	910 k $\Omega$	290 k $\Omega$

TIMING DIAGRAM

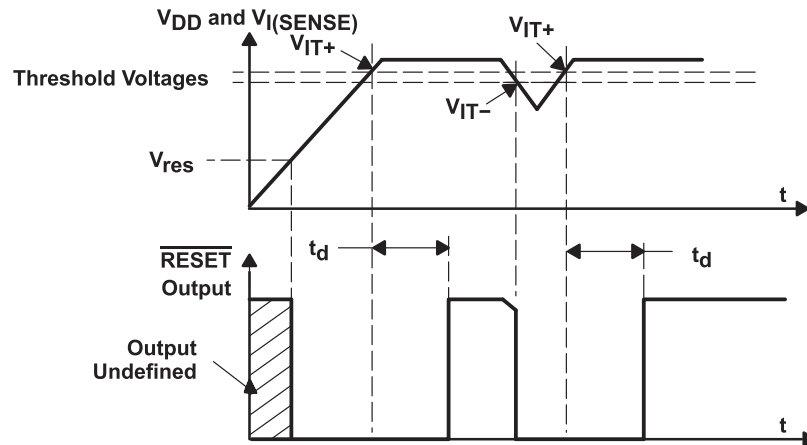

## ABSOLUTE MAXIMUM RATINGS<sup>(1)</sup>

over operating free-air temperature range (unless otherwise noted)

		VALUE	UNIT
V <sub>DD</sub>	Supply voltage <sup>(2)</sup>	7	V
	Input voltage range, CONTROL, RESIN, SENSE <sup>(2)</sup>	–0.3 to 7	V
I <sub>OL</sub>	Maximum low output current	10	mA
I <sub>OH</sub>	Maximum high output current,	–10	mA
I <sub>IK</sub>	Input clamp current, (VI < 0 or VI > VDD)	±10	mA
I <sub>OK</sub>	Output clamp current, (VO 0 or VO > VDD)	±10	mA
	Continuous total power dissipation	See Dissipation Rating Table	
T <sub>A</sub>	Operating free-air temperature range	TL77xxI	–40 to 84 °C
		TL77xxQ	–40 to 125 °C
		TL77xxM	–55 to 125 °C
T <sub>stg</sub>	Storage temperature range	–65 to 150	°C

- (1) Stresses beyond those listed under "absolute maximum ratings" may cause permanent damage to the device. These are stress ratings only, and functional operation of the device at these or any other conditions beyond those indicated under "recommended operating conditions" is not implied. Exposure to absolute-maximum-rated conditions for extended periods may affect device reliability.
- (2) All voltage values are with respect to GND.

## DISSIPATION RATINGS

PACKAGE	T <sub>A</sub> ≤ 25°C POWER RATING	DERATING FACTOR ABOVE T <sub>A</sub> = 25°C	T <sub>A</sub> = 85°C POWER RATING	T <sub>A</sub> = 125°C POWER RATING
D	725 mW	5.8 mW/°C	377 mW	145 mW
DRB				
FK	1375 mW	11.0 mW/°C	715 mW	275 mW
JG	1050 mW	8.4 mW/°C	546 mW	210 mW
P	1000 mW	8.0 mW/°C	520 mW	200 mW
PW	525 mW	4.2 mW/°C	273 mW	105 mW
U	700 mW	5.5 mW/°C	370 mW	150 mW

## RECOMMENDED OPERATING CONDITIONS

at specified temperature range

		MIN	MAX	UNIT
V <sub>DD</sub>	Supply voltage	2	6	V
V <sub>I</sub>	Input voltage	0	V <sub>DD</sub>	V
V <sub>IH</sub>	High-level input voltage at $\overline{\text{RESIN}}$ and CONTROL <sup>(1)</sup>	0.7×V <sub>DD</sub>		V
V <sub>IL</sub>	Low-level input voltage at $\overline{\text{RESIN}}$ and CONTROL <sup>(1)</sup>		0.2×V <sub>DD</sub>	V
I <sub>OH</sub>	High-level output current		–2	mA
I <sub>OL</sub>	Low-level output current		2	mA
Δt/ΔV	input transition rise and fall rate at $\overline{\text{RESIN}}$ and CONTROL		100	ns/ V
T <sub>A</sub>	Operating free-air temperature range	TL77xxI	–40	85
		TL77xxQ	–40	125
		TL77xxM	–55	125

- (1) To ensure a low supply current, V<sub>IL</sub> should be kept < 0.3 V and V<sub>IH</sub> > V<sub>DD</sub> – 0.3 V.

## ELECTRICAL CHARACTERISTICS

over recommended operating conditions<sup>(1)</sup> (unless otherwise noted)

PARAMETER		TEST CONDITIONS	TLC77xx			UNIT	
			MIN	TYP	MAX		
V <sub>OH</sub>	High-level output voltage	I <sub>OH</sub> = -20 μA	V <sub>DD</sub> = 2 V	1.8		V	
			V <sub>DD</sub> = 2.7 V	2.5			
		V <sub>DD</sub> = 4.5 V	4.3				
		I <sub>OH</sub> = 2 -mA	V <sub>DD</sub> = 4.5 V	3.7			
V <sub>OL</sub>	Low-Level output voltage	I <sub>OL</sub> = 20 μA	V <sub>DD</sub> = 2 V		0.2	V	
			V <sub>DD</sub> = 2.7 V		0.2		
			V <sub>DD</sub> = 4.5 V		0.2		
		I <sub>OL</sub> = 2 mA	V <sub>DD</sub> = 4.5 V		0.5		
V <sub>IT-</sub>	Negative-going input threshold voltage, SENSE <sup>(2)</sup>	V <sub>DD</sub> = 2 V to 6 V	TCLC7701	1.04	1.1	1.16	mV
			TLC7725	2.18	2.25	2.32	
			TLC7703	2.56	2.63	2.70	
			TLC7733	2.86	2.93	3	
			TLC7705	4.47	4.55	4.63	
V <sub>hus</sub>	Hysteresis voltage, SENSE	V <sub>DD</sub> = 2 V to 6 V	TCLC7701	30		mV	
			TLC7725				
			TLC7703	70			
			TLC7733				
			TLC7705				
V <sub>res</sub>	Power-up reset voltage <sup>(3)</sup>	I <sub>OL</sub> = 20 μA			1	V	
I <sub>i</sub>	Input current	RESIN	V <sub>I</sub> = 0 V to V <sub>DD</sub>		2	μA	
		CONTROL	V <sub>I</sub> = V <sub>DD</sub>	7	15		
		SENSE	V <sub>I</sub> = 5 V	5	10		
		SENSE, TLC7701 only	V <sub>I</sub> = 5 V		2		
I <sub>DD</sub>	Supply current	RESIN = V <sub>DD</sub> , SENSE = V <sub>DD</sub> ≥ V <sub>ITmax</sub> + 0.2 V, CONTROL = 0 V, Outputs open		9	16	μA	
I <sub>DD(d)</sub>	Supply current during t <sub>d</sub>	V <sub>DD</sub> = 5 V, V <sub>CT</sub> = 0, RESIN = V <sub>DD</sub> , SENSE = V <sub>DD</sub> , CONTROL = 0 V, Outputs open		120	150	μA	
C <sub>i</sub>	Input capacitance, SENSE	V <sub>I</sub> = 0 V to V <sub>DD</sub>		50		pF	

(1) All characteristics are measured with C<sub>T</sub> = 0.1 μF.

(2) To ensure best stability of the threshold voltage, a bypass capacitor (ceramic, 0.1 mF) should be connected near the supply terminals.

(3) The lowest supply voltage at which RESET becomes active. The symbol V<sub>res</sub> is not currently listed within EIA or JEDEC standards for semiconductor symbology. Rise time of V<sub>DD</sub> ≥ 15 μs/V.

## ELECTRICAL CHARACTERISTICS

 over recommended operating conditions<sup>(1)</sup> (unless otherwise noted)

PARAMETER		TEST CONDITIONS		TLC77xxM			UNIT	
				MIN	TYP <sup>(2)</sup>	MAX		
$V_{OH}$	High-level output voltage	$I_{OH} = -20 \mu A$	$V_{DD} = 2 V$	$T_A = 25^\circ C$	1.8		V	
				$T_A = -55^\circ C$ to $125^\circ C$	1.7			
			$V_{DD} = 2.7 V$	$T_A = 25^\circ C$	2.5		V	
				$T_A = -55^\circ C$ to $125^\circ C$	2.3			
			$V_{DD} = 4.5 V$	$T_A = 25^\circ C$	4.3		V	
				$T_A = -55^\circ C$ to $125^\circ C$	4.2			
$I_{OH} = -2 \mu A$	$V_{DD} = 4.5 V$	$T_A = 25^\circ C$	3.7		V			
		$T_A = -55^\circ C$ to $125^\circ C$	3.6					
$V_{OL}$	Low-level output voltage	$I_{OL} = -20 \mu A$	$V_{DD} = 2 V$	$T_A = 25^\circ C$		0.2	V	
				$T_A = -55^\circ C$ to $125^\circ C$		0.2		
			$V_{DD} = 2.7 V$	$T_A = 25^\circ C$		0.2	V	
				$T_A = -55^\circ C$ to $125^\circ C$		0.2		
			$V_{DD} = 4.5 V$	$T_A = 25^\circ C$		0.2	V	
				$T_A = -55^\circ C$ to $125^\circ C$		0.2		
			$I_{OL} = 2 mA$	$V_{DD} = 4.5 V$	$T_A = 25^\circ C$		0.5	V
					$T_A = -55^\circ C$ to $125^\circ C$		0.5	
$V_{IT-}$	Negative-going input threshold voltage, SENSE <sup>(3)</sup>	TLC7733	$V_{DD} = 2 V$ to $6 V$	2.86	2.93	3.1	V	
		TLC7705		4.3	4.5	4.8		
$V_{hys}$	Hysteresis voltage, SENSE		$V_{DD} = 2 V$ to $6 V$		70		mV	
$V_{res}$	Power-up reset voltage <sup>(2)</sup>		$I_{OL} = 20 \mu A$			1	V	
$I_i$	Input current	RESIN	$V_i = 0 V$ to $V_{DD}$			2	$\mu A$	
		CONTROL	$V_i = V_{DD}$		7	15		
		SENSE	$V_i = 5 V$		5	10		
		SENSE, TLC7701 only	$V_i = 5 V$			2		
$I_{DD}$	Supply current		RESIN = $V_{DD}$ , SENSE = $V_{DD} \geq V_{ITmax} + 0.2 V$ , CONTROL = $0 V$ , Outputs open		9	16	$\mu A$	
$I_{DD(d)}$	Supply current during $t_d$	TLC7733	$V_{CT} = 0$ , RESIN = $V_{DD}$ , CONTROL = $0 V$ , SENSE = $V_{DD}$ , Outputs open	$V_{DD} = 3.3 V$		250	$\mu A$	
		TLC7705		$V_{DD} = 5 V$		120 150		
$C_i$	Input capacitance, SENSE		$V_i = 0 V$ to $V_{DD}$			50	pF	

 (1) All characteristics are measured with  $C_T = 0.1 \mu F$ .

 (2) Typical values apply at  $T_A = 25^\circ C$ .

(3) To ensure best stability of the threshold voltage, a bypass capacitor (ceramic, 0.1 mF) should be connected near the supply terminals.

## SWITCHING CHARACTERISTICS

at  $V_{DD} = 5\text{ V}$ ,  $R_L = 2\text{ k}\Omega$ ,  $C_L = 50\text{ pF}$ ,  $T_A = 25^\circ\text{C}$  (unless otherwise noted)

PARAMETER	MEASURED		TEST CONDITIONS	TLC77xx			UNIT
	FROM (INPUT)	TO (OUTPUT)		MIN	TYP	MAX	
$t_d$ Delay time	$V_{I(\text{SENSE})} \geq V_{IT+}$	RESET and RESET	$\overline{\text{RESIN}} = 0.7 \times V_{DD}$ , CONTROL = $0.2 \times V_{DD}$ , $C_T = 100\text{ nF}$ , $T_A = \text{Full range}$ , See timing diagram	1.1	2.1	4.2	ms
$t_{PLH}$ Propagation delay time, low-to-high-level output	SENSE	$\overline{\text{RESET}}$	$V_{IH} = V_{IT+max} + 0.2\text{ V}$ , $V_{IL} = V_{IT.min} - 0.2\text{ V}$ , $\overline{\text{RESIN}} = 0.7 \times V_{DD}$ , CONTROL = $0.2 \times V_{DD}$ , CT = NC <sup>(1)</sup>	20			$\mu\text{s}$
$t_{PHL}$ Propagation delay time, high-to-low-level output		$\overline{\text{RESET}}$		5			
$t_{PLH}$ Propagation delay time, low-to-high-level output		RESET		5			
$t_{PHL}$ Propagation delay time, high-to-low-level output		RESET		20			
$t_{PLH}$ Propagation delay time, low-to-high-level output	$\overline{\text{RESIN}}$	$\overline{\text{RESET}}$	$V_{IH} = 0.7 \times V_{DD}$ , $V_{IL} = 0.2 \times V_{DD}$ , SENSE = $V_{IT+max} + 0.2\text{ V}$ , CONTROL = $0.2 \times V_{DD}$ , CT = NC <sup>(1)</sup>	20			$\mu\text{s}$
$t_{PHL}$ Propagation delay time, high-to-low-level output		$\overline{\text{RESET}}$		40			
$t_{PLH}$ Propagation delay time, low-to-high-level output		RESET		45			
$t_{PHL}$ Propagation delay time, high-to-low-level output		RESET		20			
$t_{PLH}$ Propagation delay time, low-to-high-level output	CONTROL	RESET	$V_{IH} = 0.7 \times V_{DD}$ , $V_{IL} = 0.2 \times V_{DD}$ , SENSE = $V_{IT+max} + 0.2\text{ V}$ , $\overline{\text{RESIN}} = 0.7 \times V_{DD}$ , CT = NC <sup>(1)</sup>	38			ns
$t_{PHL}$ Propagation delay time, high-to-low-level output				38			
Low-level minimum pulse duration to switch RESET and $\overline{\text{RESET}}$	SENSE		$V_{IH} = V_{IT+max} + 0.2\text{ V}$ , $V_{IL} = V_{IT.min} - 0.2\text{ V}$ , $V_{IL} = 0.2 \times V_{DD}$ , $V_{IH} = 0.7 \times V_{DD}$				
	$\overline{\text{RESIN}}$						
$t_r$ Rise time		RESET and RESET	10% to 90%				
$t_f$ Fall time		RESET and RESET	90% to 10%				

(1) NC = No capacitor, and includes up to 100-pF probe and jig capacitance.

## SWITCHING CHARACTERISTICS

 at  $V_{DD} = 5\text{ V}$ ,  $R_L = 2\text{ k}\Omega$ ,  $C_L = 50\text{ pF}$ ,  $T_A = 25^\circ\text{C}$  (unless otherwise noted)

PARAMETER	MEASURED		TEST CONDITIONS	$T_A$	TLC77xxM			UNIT
	FROM (INPUT)	TO (OUTPUT)			MIN	TYP	MAX	
$t_d$ Delay time	$V_{I(\text{SENSE})} \geq V_{IT+}$	RESET and RESET	RESIN = 2.7 V, CONTROL = 0.4 V, $C_T = 100\text{ nF}$ , See timing diagram	Full range	1.1	2.1	4.2	ms
$t_{PLH}$ Propagation delay time, low-to-high-level output	SENSE	RESET	$V_{IH} = V_{IT+max} + 0.2\text{ V}$ , $V_{IL} = V_{IT-min} - 0.2\text{ V}$ , RESIN = 2.7 V, CONTROL = 0.4 V, CT = NC <sup>(1)</sup>	25°C			20	$\mu\text{s}$
		Full range				24		
		RESET		25°C			5	$\mu\text{s}$
		Full range				7		
$t_{PHL}$ Propagation delay time, high-to-low-level output	SENSE	RESET	$V_{IH} = V_{IT+max} + 0.2\text{ V}$ , $V_{IL} = V_{IT-min} - 0.2\text{ V}$ , RESIN = 2.7 V, CONTROL = 0.4 V, CT = NC <sup>(1)</sup>	25°C			5	$\mu\text{s}$
		Full range				7		
		RESET		25°C			20	$\mu\text{s}$
		Full range				24		
$t_{PLH}$ Propagation delay time, low-to-high-level output	RESIN	RESET	$V_{IH} = 2.7\text{ V}$ , $V_{IL} = 0.4\text{ V}$ , SENSE = $V_{IT+max} + 0.2\text{ V}$ , CONTROL = 0.4 V, CT = NC <sup>(1)</sup>	25°C			20	$\mu\text{s}$
		Full range				24		
		RESET		25°C			45	ns
		Full range				65		
$t_{PHL}$ Propagation delay time, high-to-low-level output	RESIN	RESET	$V_{IH} = 2.7\text{ V}$ , $V_{IL} = 0.4\text{ V}$ , SENSE = $V_{IT+max} + 0.2\text{ V}$ , CONTROL = 0.4 V, CT = NC <sup>(1)</sup>	25°C			40	ns
		Full range				60		
		RESET		25°C			20	$\mu\text{s}$
		Full range				24		
$t_{PLH}$ Propagation delay time, low-to-high-level output	CONTROL	RESET	$V_{IH} = 2.7\text{ V}$ , $V_{IL} = 0.4\text{ V}$ , SENSE = $V_{IT+max} + 0.2\text{ V}$ , RESIN = 2.7 V, CT = NC <sup>(1)</sup>	25°C			38	ns
				Full range			58	
$t_{PHL}$ Propagation delay time, high-to-low-level output	CONTROL	RESET	$V_{IH} = 2.7\text{ V}$ , $V_{IL} = 0.4\text{ V}$ , SENSE = $V_{IT+max} + 0.2\text{ V}$ , RESIN = 2.7 V, CT = NC <sup>(1)</sup>	25°C			38	ns
				Full Range			58	
Low-level minimum pulse duration	SENSE		$V_{IH} = V_{IT+max} + 0.2\text{ V}$ , $V_{IL} = V_{IT-min} - 0.2\text{ V}$	Full range			3	$\mu\text{s}$
	RESIN						1	
$t_r$ Rise time		RESET and RESET	10% to 90%	Full range			8	ns/V
$t_f$ Fall time			90% to 10%				4	

(1) NC = No capacitor, and includes up to 100-pF probe and jig capacitance.

PARAMETER MEASUREMENT INFORMATION

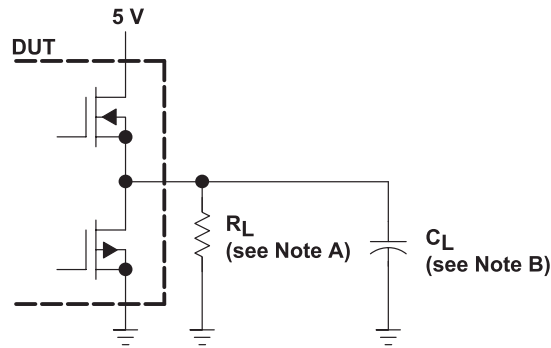

NOTES: A. For switching characteristics,  $R_L = 2\text{ k}\Omega$ .  
B.  $C_L = 50\text{ pF}$  includes jig and probe capacitance.

Figure 1. RESET and  $\overline{\text{RESET}}$  Output Configurations

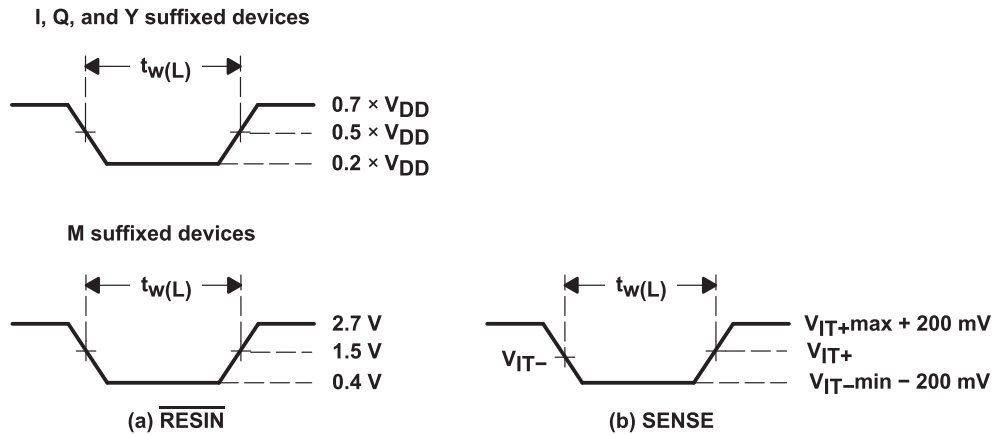

Figure 2. Input Pulse Definition Waveforms

TYPICAL CHARACTERISTICS

NORMALIZED INPUT THRESHOLD VOLTAGE  
vs  
TEMPERATURE



Figure 3.

SUPPLY CURRENT  
vs  
SUPPLY VOLTAGE



Figure 4.

HIGH-LEVEL OUTPUT VOLTAGE  
vs  
HIGH-LEVEL OUTPUT CURRENT



Figure 5.

LOW-LEVEL OUTPUT VOLTAGE  
vs  
LOW-LEVEL OUTPUT CURRENT



Figure 6.

**TYPICAL CHARACTERISTICS (continued)**

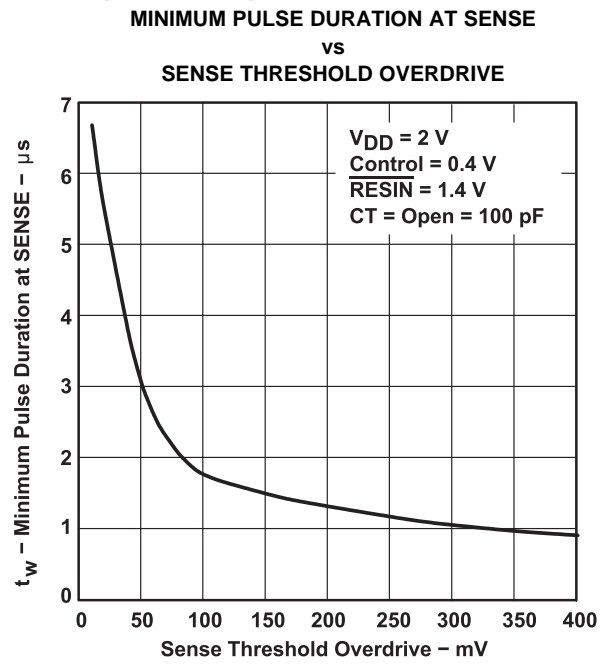
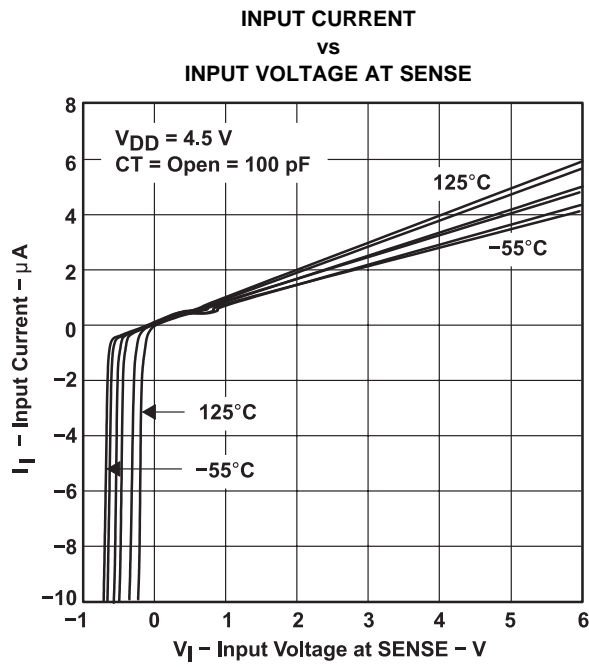

APPLICATION INFORMATION

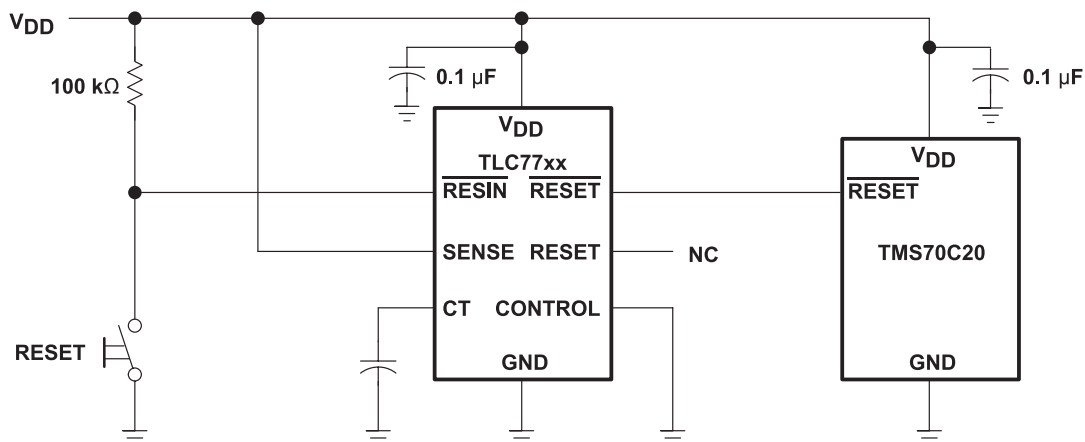

Figure 9. Reset Controller in a Microcomputer System

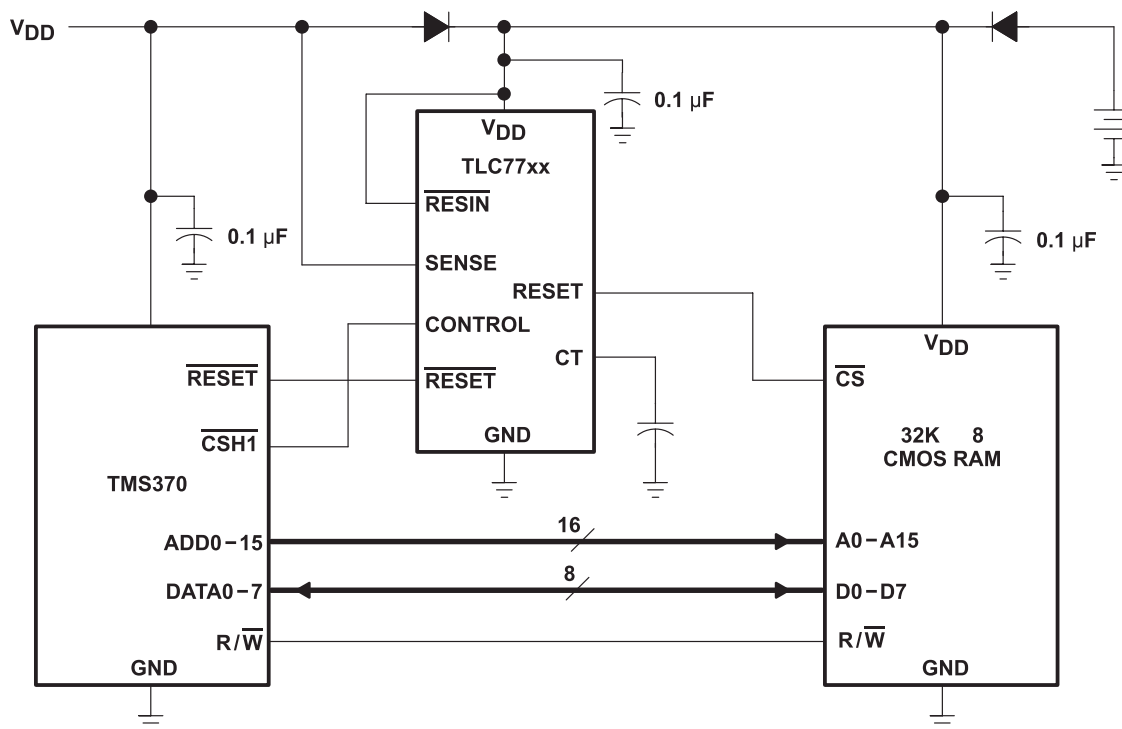

Figure 10. Data Retention During Power Down Using Static CMOS RAMs

---

**Changes from Revision L (February 2003) to Revision M**

**Page**

- 
- Updated the DRB package Pin Out dimensions and Ordering Information. .... 1
-

**PACKAGING INFORMATION**

Orderable Device	Status (1)	Package Type	Package Drawing	Pins	Package Qty	Eco Plan (2)	Lead/Ball Finish (6)	MSL Peak Temp (3)	Op Temp (°C)	Device Marking (4/5)	Samples
5962-9750901Q2A	ACTIVE	LCCC	FK	20	1	TBD	POST-PLATE	N / A for Pkg Type	-55 to 125	5962-9750901Q2A TLC7733 MFKB	<a href="#">Samples</a>
5962-9750901QPA	ACTIVE	CDIP	JG	8	1	TBD	A42	N / A for Pkg Type	-55 to 125	9750901QPA TLC7733M	<a href="#">Samples</a>
5962-9751301Q2A	ACTIVE	LCCC	FK	20	1	TBD	POST-PLATE	N / A for Pkg Type	-55 to 125	5962-9751301Q2A TLC7705 MFKB	<a href="#">Samples</a>
5962-9751301QHA	ACTIVE	CFP	U	10	1	TBD	A42	N / A for Pkg Type	-55 to 125	9751301QHA TLC7705M	<a href="#">Samples</a>
5962-9751301QPA	ACTIVE	CDIP	JG	8	1	TBD	A42	N / A for Pkg Type	-55 to 125	9751301QPA TLC7705M	<a href="#">Samples</a>
TLC7701ID	ACTIVE	SOIC	D	8	75	Green (RoHS & no Sb/Br)	CU NIPDAU	Level-1-260C-UNLIM	-40 to 85	C7701I	<a href="#">Samples</a>
TLC7701IDG4	ACTIVE	SOIC	D	8	75	Green (RoHS & no Sb/Br)	CU NIPDAU	Level-1-260C-UNLIM	-40 to 85	C7701I	<a href="#">Samples</a>
TLC7701IDR	ACTIVE	SOIC	D	8	2500	Green (RoHS & no Sb/Br)	CU NIPDAU	Level-1-260C-UNLIM	-40 to 85	C7701I	<a href="#">Samples</a>
TLC7701IDRBT-NM	ACTIVE	SON	DRB	8	250	Green (RoHS & no Sb/Br)	CU SN	Level-2-260C-1 YEAR	-40 to 125	7701N	<a href="#">Samples</a>
TLC7701IDRG4	ACTIVE	SOIC	D	8	2500	Green (RoHS & no Sb/Br)	CU NIPDAU	Level-1-260C-UNLIM	-40 to 85	C7701I	<a href="#">Samples</a>
TLC7701IP	ACTIVE	PDIP	P	8	50	Green (RoHS & no Sb/Br)	CU NIPDAU	N / A for Pkg Type	-40 to 85	TLC7701IP	<a href="#">Samples</a>
TLC7701IPW	ACTIVE	TSSOP	PW	8	150	Green (RoHS & no Sb/Br)	CU NIPDAU	Level-1-260C-UNLIM	-40 to 85	Y7701	<a href="#">Samples</a>
TLC7701IPWR	ACTIVE	TSSOP	PW	8	2000	Green (RoHS & no Sb/Br)	CU NIPDAU	Level-1-260C-UNLIM	-40 to 85	Y7701	<a href="#">Samples</a>
TLC7701IPWRG4	ACTIVE	TSSOP	PW	8	2000	Green (RoHS & no Sb/Br)	CU NIPDAU	Level-1-260C-UNLIM	-40 to 85	Y7701	<a href="#">Samples</a>
TLC7701QD	ACTIVE	SOIC	D	8	75	Green (RoHS & no Sb/Br)	CU NIPDAU	Level-1-260C-UNLIM	-40 to 125	C7701Q	<a href="#">Samples</a>

Orderable Device	Status (1)	Package Type	Package Drawing	Pins	Package Qty	Eco Plan (2)	Lead/Ball Finish (6)	MSL Peak Temp (3)	Op Temp (°C)	Device Marking (4/5)	Samples
TLC7701QDR	ACTIVE	SOIC	D	8	2500	Green (RoHS & no Sb/Br)	CU NIPDAU	Level-1-260C-UNLIM	-40 to 125	C7701Q	<a href="#">Samples</a>
TLC7701QDRG4	ACTIVE	SOIC	D	8	2500	Green (RoHS & no Sb/Br)	CU NIPDAU	Level-1-260C-UNLIM	-40 to 125	C7701Q	<a href="#">Samples</a>
TLC7701QP	ACTIVE	PDIP	P	8	50	Green (RoHS & no Sb/Br)	CU NIPDAU	N / A for Pkg Type	-40 to 125	TLC7701QP	<a href="#">Samples</a>
TLC7701QPW	ACTIVE	TSSOP	PW	8	150	Green (RoHS & no Sb/Br)	CU NIPDAU	Level-1-260C-UNLIM	-40 to 125	TD701	<a href="#">Samples</a>
TLC7701QPWG4	ACTIVE	TSSOP	PW	8	150	Green (RoHS & no Sb/Br)	CU NIPDAU	Level-1-260C-UNLIM	-40 to 125	TD701	<a href="#">Samples</a>
TLC7701QPWR	ACTIVE	TSSOP	PW	8	2000	Green (RoHS & no Sb/Br)	CU NIPDAU	Level-1-260C-UNLIM	-40 to 125	TD701	<a href="#">Samples</a>
TLC7701QPWRG4	ACTIVE	TSSOP	PW	8	2000	Green (RoHS & no Sb/Br)	CU NIPDAU	Level-1-260C-UNLIM	-40 to 125	TD701	<a href="#">Samples</a>
TLC7703ID	ACTIVE	SOIC	D	8	75	Green (RoHS & no Sb/Br)	CU NIPDAU	Level-1-260C-UNLIM	-40 to 85	C7703I	<a href="#">Samples</a>
TLC7703IDR	ACTIVE	SOIC	D	8	2500	Green (RoHS & no Sb/Br)	CU NIPDAU	Level-1-260C-UNLIM	-40 to 85	C7703I	<a href="#">Samples</a>
TLC7703IP	ACTIVE	PDIP	P	8	50	Green (RoHS & no Sb/Br)	CU NIPDAU	N / A for Pkg Type	-40 to 85	TLC7703IP	<a href="#">Samples</a>
TLC7703IPW	ACTIVE	TSSOP	PW	8	150	Green (RoHS & no Sb/Br)	CU NIPDAU	Level-1-260C-UNLIM		Y7703	<a href="#">Samples</a>
TLC7703IPWG4	ACTIVE	TSSOP	PW	8	150	Green (RoHS & no Sb/Br)	CU NIPDAU	Level-1-260C-UNLIM		Y7703	<a href="#">Samples</a>
TLC7703IPWR	ACTIVE	TSSOP	PW	8	2000	Green (RoHS & no Sb/Br)	CU NIPDAU	Level-1-260C-UNLIM	-40 to 85	Y7703	<a href="#">Samples</a>
TLC7703QD	ACTIVE	SOIC	D	8	75	Green (RoHS & no Sb/Br)	CU NIPDAU	Level-1-260C-UNLIM	-40 to 125	C7703Q	<a href="#">Samples</a>
TLC7703QDG4	ACTIVE	SOIC	D	8	75	Green (RoHS & no Sb/Br)	CU NIPDAU	Level-1-260C-UNLIM	-40 to 125	C7703Q	<a href="#">Samples</a>
TLC7703QPW	ACTIVE	TSSOP	PW	8	150	Green (RoHS & no Sb/Br)	CU NIPDAU	Level-1-260C-UNLIM	-40 to 125	TD703	<a href="#">Samples</a>
TLC7703QPWG4	ACTIVE	TSSOP	PW	8	150	Green (RoHS & no Sb/Br)	CU NIPDAU	Level-1-260C-UNLIM	-40 to 125	TD703	<a href="#">Samples</a>
TLC7705ID	ACTIVE	SOIC	D	8	75	Green (RoHS & no Sb/Br)	CU NIPDAU	Level-1-260C-UNLIM	-40 to 85	C7705I	<a href="#">Samples</a>

Orderable Device	Status (1)	Package Type	Package Drawing	Pins	Package Qty	Eco Plan (2)	Lead/Ball Finish (6)	MSL Peak Temp (3)	Op Temp (°C)	Device Marking (4/5)	Samples
TLC7705IDR	ACTIVE	SOIC	D	8	2500	Green (RoHS & no Sb/Br)	CU NIPDAU	Level-1-260C-UNLIM	-40 to 85	C7705I	<a href="#">Samples</a>
TLC7705IP	ACTIVE	PDIP	P	8	50	Green (RoHS & no Sb/Br)	CU NIPDAU	N / A for Pkg Type	-40 to 85	TLC7705IP	<a href="#">Samples</a>
TLC7705IPE4	ACTIVE	PDIP	P	8	50	Green (RoHS & no Sb/Br)	CU NIPDAU	N / A for Pkg Type	-40 to 85	TLC7705IP	<a href="#">Samples</a>
TLC7705IPW	ACTIVE	TSSOP	PW	8	150	Green (RoHS & no Sb/Br)	CU NIPDAU	Level-1-260C-UNLIM		Y7705	<a href="#">Samples</a>
TLC7705IPWR	ACTIVE	TSSOP	PW	8	2000	Green (RoHS & no Sb/Br)	CU NIPDAU	Level-1-260C-UNLIM	-40 to 85	Y7705	<a href="#">Samples</a>
TLC7705MFKB	ACTIVE	LCCC	FK	20	1	TBD	POST-PLATE	N / A for Pkg Type	-55 to 125	5962-9751301Q2A TLC7705 MFKB	<a href="#">Samples</a>
TLC7705MJG	ACTIVE	CDIP	JG	8	1	TBD	A42	N / A for Pkg Type	-55 to 125	TLC7705 MJG	<a href="#">Samples</a>
TLC7705MJGB	ACTIVE	CDIP	JG	8	1	TBD	A42	N / A for Pkg Type	-55 to 125	9751301QPA TLC7705M	<a href="#">Samples</a>
TLC7705MUB	ACTIVE	CFP	U	10	1	TBD	A42	N / A for Pkg Type	-55 to 125	9751301QHA TLC7705M	<a href="#">Samples</a>
TLC7705QD	ACTIVE	SOIC	D	8	75	Green (RoHS & no Sb/Br)	CU NIPDAU	Level-1-260C-UNLIM	-40 to 125	C7705Q	<a href="#">Samples</a>
TLC7705QDR	ACTIVE	SOIC	D	8	2500	Green (RoHS & no Sb/Br)	CU NIPDAU	Level-1-260C-UNLIM	-40 to 125	C7705Q	<a href="#">Samples</a>
TLC7705QPW	ACTIVE	TSSOP	PW	8	150	Green (RoHS & no Sb/Br)	CU NIPDAU	Level-1-260C-UNLIM	-40 to 125	TD705	<a href="#">Samples</a>
TLC7705QPWR	ACTIVE	TSSOP	PW	8	2000	Green (RoHS & no Sb/Br)	CU NIPDAU	Level-1-260C-UNLIM	-40 to 125	TD705	<a href="#">Samples</a>
TLC7705QPWRG4	ACTIVE	TSSOP	PW	8	2000	Green (RoHS & no Sb/Br)	CU NIPDAU	Level-1-260C-UNLIM	-40 to 125	TD705	<a href="#">Samples</a>
TLC7725ID	ACTIVE	SOIC	D	8	75	Green (RoHS & no Sb/Br)	CU NIPDAU	Level-1-260C-UNLIM	-40 to 85	C7725I	<a href="#">Samples</a>
TLC7725IDG4	ACTIVE	SOIC	D	8	75	Green (RoHS & no Sb/Br)	CU NIPDAU	Level-1-260C-UNLIM	-40 to 85	C7725I	<a href="#">Samples</a>
TLC7725IDR	ACTIVE	SOIC	D	8	2500	Green (RoHS & no Sb/Br)	CU NIPDAU	Level-1-260C-UNLIM	-40 to 85	C7725I	<a href="#">Samples</a>

Orderable Device	Status (1)	Package Type	Package Drawing	Pins	Package Qty	Eco Plan (2)	Lead/Ball Finish (6)	MSL Peak Temp (3)	Op Temp (°C)	Device Marking (4/5)	Samples
TLC7725IDRG4	ACTIVE	SOIC	D	8	2500	Green (RoHS & no Sb/Br)	CU NIPDAU	Level-1-260C-UNLIM	-40 to 85	C7725I	<a href="#">Samples</a>
TLC7725IPW	ACTIVE	TSSOP	PW	8	150	Green (RoHS & no Sb/Br)	CU NIPDAU	Level-1-260C-UNLIM		Y7725	<a href="#">Samples</a>
TLC7725IPWR	ACTIVE	TSSOP	PW	8	2000	Green (RoHS & no Sb/Br)	CU NIPDAU	Level-1-260C-UNLIM	-40 to 85	Y7725	<a href="#">Samples</a>
TLC7725QD	ACTIVE	SOIC	D	8	75	Green (RoHS & no Sb/Br)	CU NIPDAU	Level-1-260C-UNLIM	-40 to 125	C7725Q	<a href="#">Samples</a>
TLC7725QDG4	ACTIVE	SOIC	D	8	75	Green (RoHS & no Sb/Br)	CU NIPDAU	Level-1-260C-UNLIM	-40 to 125	C7725Q	<a href="#">Samples</a>
TLC7725QDR	ACTIVE	SOIC	D	8	2500	Green (RoHS & no Sb/Br)	CU NIPDAU	Level-1-260C-UNLIM	-40 to 125	C7725Q	<a href="#">Samples</a>
TLC7725QPWR	ACTIVE	TSSOP	PW	8	2000	Green (RoHS & no Sb/Br)	CU NIPDAU	Level-1-260C-UNLIM	-40 to 125	TD725	<a href="#">Samples</a>
TLC7725QPWRG4	ACTIVE	TSSOP	PW	8	2000	Green (RoHS & no Sb/Br)	CU NIPDAU	Level-1-260C-UNLIM	-40 to 125	TD725	<a href="#">Samples</a>
TLC7733ID	ACTIVE	SOIC	D	8	75	Green (RoHS & no Sb/Br)	CU NIPDAU	Level-1-260C-UNLIM	-40 to 85	C7733I	<a href="#">Samples</a>
TLC7733IDG4	ACTIVE	SOIC	D	8	75	Green (RoHS & no Sb/Br)	CU NIPDAU	Level-1-260C-UNLIM	-40 to 85	C7733I	<a href="#">Samples</a>
TLC7733IDR	ACTIVE	SOIC	D	8	2500	Green (RoHS & no Sb/Br)	CU NIPDAU	Level-1-260C-UNLIM	-40 to 85	C7733I	<a href="#">Samples</a>
TLC7733IDRG4	ACTIVE	SOIC	D	8	2500	Green (RoHS & no Sb/Br)	CU NIPDAU	Level-1-260C-UNLIM	-40 to 85	C7733I	<a href="#">Samples</a>
TLC7733IP	ACTIVE	PDIP	P	8	50	Green (RoHS & no Sb/Br)	CU NIPDAU	N / A for Pkg Type	-40 to 85	TLC7733IP	<a href="#">Samples</a>
TLC7733IPE4	ACTIVE	PDIP	P	8	50	Green (RoHS & no Sb/Br)	CU NIPDAU	N / A for Pkg Type	-40 to 85	TLC7733IP	<a href="#">Samples</a>
TLC7733IPW	ACTIVE	TSSOP	PW	8	150	Green (RoHS & no Sb/Br)	CU NIPDAU	Level-1-260C-UNLIM		Y7733	<a href="#">Samples</a>
TLC7733IPWR	ACTIVE	TSSOP	PW	8	2000	Green (RoHS & no Sb/Br)	CU NIPDAU	Level-1-260C-UNLIM	-40 to 85	Y7733	<a href="#">Samples</a>
TLC7733IPWRG4	ACTIVE	TSSOP	PW	8	2000	Green (RoHS & no Sb/Br)	CU NIPDAU	Level-1-260C-UNLIM	-40 to 85	Y7733	<a href="#">Samples</a>
TLC7733MFKB	ACTIVE	LCCC	FK	20	1	TBD	POST-PLATE	N / A for Pkg Type	-55 to 125	5962-9750901Q2A	<a href="#">Samples</a>

Orderable Device	Status (1)	Package Type	Package Drawing	Pins	Package Qty	Eco Plan (2)	Lead/Ball Finish (6)	MSL Peak Temp (3)	Op Temp (°C)	Device Marking (4/5)	Samples
										TLC7733 MFKB	
TLC7733MJG	ACTIVE	CDIP	JG	8	1	TBD	A42	N / A for Pkg Type	-55 to 125	TLC7733 MJG	<a href="#">Samples</a>
TLC7733MJGB	ACTIVE	CDIP	JG	8	1	TBD	A42	N / A for Pkg Type	-55 to 125	9750901QPA TLC7733M	<a href="#">Samples</a>
TLC7733QD	ACTIVE	SOIC	D	8	75	Green (RoHS & no Sb/Br)	CU NIPDAU	Level-1-260C-UNLIM	-40 to 125	C7733Q	<a href="#">Samples</a>
TLC7733QDR	ACTIVE	SOIC	D	8	2500	Green (RoHS & no Sb/Br)	CU NIPDAU	Level-1-260C-UNLIM	-40 to 125	C7733Q	<a href="#">Samples</a>
TLC7733QP	ACTIVE	PDIP	P	8	50	Green (RoHS & no Sb/Br)	CU NIPDAU	N / A for Pkg Type	-40 to 125	TLC7733QP	<a href="#">Samples</a>
TLC7733QPW	ACTIVE	TSSOP	PW	8	150	Green (RoHS & no Sb/Br)	CU NIPDAU	Level-1-260C-UNLIM	-40 to 125	TD733	<a href="#">Samples</a>
TLC7733QPWR	ACTIVE	TSSOP	PW	8	2000	Green (RoHS & no Sb/Br)	CU NIPDAU	Level-1-260C-UNLIM	-40 to 125	TD733	<a href="#">Samples</a>
TLC7733QPWRG4	ACTIVE	TSSOP	PW	8	2000	Green (RoHS & no Sb/Br)	CU NIPDAU	Level-1-260C-UNLIM	-40 to 125	TD733	<a href="#">Samples</a>

(1) The marketing status values are defined as follows:

**ACTIVE:** Product device recommended for new designs.

**LIFEBUY:** TI has announced that the device will be discontinued, and a lifetime-buy period is in effect.

**NRND:** Not recommended for new designs. Device is in production to support existing customers, but TI does not recommend using this part in a new design.

**PREVIEW:** Device has been announced but is not in production. Samples may or may not be available.

**OBSELETE:** TI has discontinued the production of the device.

(2) **RoHS:** TI defines "RoHS" to mean semiconductor products that are compliant with the current EU RoHS requirements for all 10 RoHS substances, including the requirement that RoHS substance do not exceed 0.1% by weight in homogeneous materials. Where designed to be soldered at high temperatures, "RoHS" products are suitable for use in specified lead-free processes. TI may reference these types of products as "Pb-Free".

**RoHS Exempt:** TI defines "RoHS Exempt" to mean products that contain lead but are compliant with EU RoHS pursuant to a specific EU RoHS exemption.

**Green:** TI defines "Green" to mean the content of Chlorine (Cl) and Bromine (Br) based flame retardants meet JS709B low halogen requirements of <=1000ppm threshold. Antimony trioxide based flame retardants must also meet the <=1000ppm threshold requirement.

(3) MSL, Peak Temp. - The Moisture Sensitivity Level rating according to the JEDEC industry standard classifications, and peak solder temperature.

(4) There may be additional marking, which relates to the logo, the lot trace code information, or the environmental category on the device.

(5) Multiple Device Markings will be inside parentheses. Only one Device Marking contained in parentheses and separated by a "-" will appear on a device. If a line is indented then it is a continuation of the previous line and the two combined represent the entire Device Marking for that device.

(6) Lead/Ball Finish - Orderable Devices may have multiple material finish options. Finish options are separated by a vertical ruled line. Lead/Ball Finish values may wrap to two lines if the finish value exceeds the maximum column width.

**Important Information and Disclaimer:**The information provided on this page represents TI's knowledge and belief as of the date that it is provided. TI bases its knowledge and belief on information provided by third parties, and makes no representation or warranty as to the accuracy of such information. Efforts are underway to better integrate information from third parties. TI has taken and continues to take reasonable steps to provide representative and accurate information but may not have conducted destructive testing or chemical analysis on incoming materials and chemicals. TI and TI suppliers consider certain information to be proprietary, and thus CAS numbers and other limited information may not be available for release.

In no event shall TI's liability arising out of such information exceed the total purchase price of the TI part(s) at issue in this document sold by TI to Customer on an annual basis.

**OTHER QUALIFIED VERSIONS OF TLC77 :**

- Automotive: [TLC77-Q1](#)
- Enhanced Product: [TLC77-EP](#)

NOTE: Qualified Version Definitions:

- Automotive - Q100 devices qualified for high-reliability automotive applications targeting zero defects
- Enhanced Product - Supports Defense, Aerospace and Medical Applications

**TAPE AND REEL INFORMATION**

**QUADRANT ASSIGNMENTS FOR PIN 1 ORIENTATION IN TAPE**

\*All dimensions are nominal

Device	Package Type	Package Drawing	Pins	SPQ	Reel Diameter (mm)	Reel Width W1 (mm)	A0 (mm)	B0 (mm)	K0 (mm)	P1 (mm)	W (mm)	Pin1 Quadrant
TLC7701IDR	SOIC	D	8	2500	330.0	12.4	6.4	5.2	2.1	8.0	12.0	Q1
TLC7701IDRBT-NM	SON	DRB	8	250	180.0	12.4	3.3	3.3	1.1	8.0	12.0	Q2
TLC7701IPWR	TSSOP	PW	8	2000	330.0	12.4	7.0	3.6	1.6	8.0	12.0	Q1
TLC7701QDR	SOIC	D	8	2500	330.0	12.4	6.4	5.2	2.1	8.0	12.0	Q1
TLC7701QPWR	TSSOP	PW	8	2000	330.0	12.4	7.0	3.6	1.6	8.0	12.0	Q1
TLC7703IDR	SOIC	D	8	2500	330.0	12.4	6.4	5.2	2.1	8.0	12.0	Q1
TLC7703IPWR	TSSOP	PW	8	2000	330.0	12.4	7.0	3.6	1.6	8.0	12.0	Q1
TLC7705IDR	SOIC	D	8	2500	330.0	12.4	6.4	5.2	2.1	8.0	12.0	Q1
TLC7705IPWR	TSSOP	PW	8	2000	330.0	12.4	7.0	3.6	1.6	8.0	12.0	Q1
TLC7705QDR	SOIC	D	8	2500	330.0	12.4	6.4	5.2	2.1	8.0	12.0	Q1
TLC7705QPWR	TSSOP	PW	8	2000	330.0	12.4	7.0	3.6	1.6	8.0	12.0	Q1
TLC7725IDR	SOIC	D	8	2500	330.0	12.4	6.4	5.2	2.1	8.0	12.0	Q1
TLC7725IPWR	TSSOP	PW	8	2000	330.0	12.4	7.0	3.6	1.6	8.0	12.0	Q1
TLC7725QDR	SOIC	D	8	2500	330.0	12.4	6.4	5.2	2.1	8.0	12.0	Q1
TLC7725QPWR	TSSOP	PW	8	2000	330.0	12.4	7.0	3.6	1.6	8.0	12.0	Q1
TLC7733IDR	SOIC	D	8	2500	330.0	12.4	6.4	5.2	2.1	8.0	12.0	Q1
TLC7733IPWR	TSSOP	PW	8	2000	330.0	12.4	7.0	3.6	1.6	8.0	12.0	Q1
TLC7733QDR	SOIC	D	8	2500	330.0	12.4	6.4	5.2	2.1	8.0	12.0	Q1

Device	Package Type	Package Drawing	Pins	SPQ	Reel Diameter (mm)	Reel Width W1 (mm)	A0 (mm)	B0 (mm)	K0 (mm)	P1 (mm)	W (mm)	Pin1 Quadrant
TLC7733QPWR	TSSOP	PW	8	2000	330.0	12.4	7.0	3.6	1.6	8.0	12.0	Q1

**TAPE AND REEL BOX DIMENSIONS**

\*All dimensions are nominal

Device	Package Type	Package Drawing	Pins	SPQ	Length (mm)	Width (mm)	Height (mm)
TLC7701IDR	SOIC	D	8	2500	350.0	350.0	43.0
TLC7701IDRBT-NM	SON	DRB	8	250	210.0	185.0	35.0
TLC7701IPWR	TSSOP	PW	8	2000	367.0	367.0	35.0
TLC7701QDR	SOIC	D	8	2500	350.0	350.0	43.0
TLC7701QPWR	TSSOP	PW	8	2000	367.0	367.0	35.0
TLC7703IDR	SOIC	D	8	2500	350.0	350.0	43.0
TLC7703IPWR	TSSOP	PW	8	2000	367.0	367.0	35.0
TLC7705IDR	SOIC	D	8	2500	350.0	350.0	43.0
TLC7705IPWR	TSSOP	PW	8	2000	367.0	367.0	35.0
TLC7705QDR	SOIC	D	8	2500	350.0	350.0	43.0
TLC7705QPWR	TSSOP	PW	8	2000	367.0	367.0	35.0
TLC7725IDR	SOIC	D	8	2500	350.0	350.0	43.0
TLC7725IPWR	TSSOP	PW	8	2000	367.0	367.0	35.0
TLC7725QDR	SOIC	D	8	2500	350.0	350.0	43.0
TLC7725QPWR	TSSOP	PW	8	2000	367.0	367.0	35.0
TLC7733IDR	SOIC	D	8	2500	367.0	367.0	35.0

---

Device	Package Type	Package Drawing	Pins	SPQ	Length (mm)	Width (mm)	Height (mm)
TLC7733IPWR	TSSOP	PW	8	2000	367.0	367.0	35.0
TLC7733QDR	SOIC	D	8	2500	367.0	367.0	35.0
TLC7733QPWR	TSSOP	PW	8	2000	367.0	367.0	35.0

FK (S-CQCC-N\*\*)

LEADLESS CERAMIC CHIP CARRIER

28 TERMINAL SHOWN



NO. OF TERMINALS **	A		B	
	MIN	MAX	MIN	MAX
20	0.342 (8,69)	0.358 (9,09)	0.307 (7,80)	0.358 (9,09)
28	0.442 (11,23)	0.458 (11,63)	0.406 (10,31)	0.458 (11,63)
44	0.640 (16,26)	0.660 (16,76)	0.495 (12,58)	0.560 (14,22)
52	0.740 (18,78)	0.761 (19,32)	0.495 (12,58)	0.560 (14,22)
68	0.938 (23,83)	0.962 (24,43)	0.850 (21,6)	0.858 (21,8)
84	1.141 (28,99)	1.165 (29,59)	1.047 (26,6)	1.063 (27,0)



4040140/D 01/11

- NOTES:
- All linear dimensions are in inches (millimeters).
  - This drawing is subject to change without notice.
  - This package can be hermetically sealed with a metal lid.
  - Falls within JEDEC MS-004

**DRB 8**

**GENERIC PACKAGE VIEW**

**VSON - 1 mm max height**

PLASTIC SMALL OUTLINE - NO LEAD



Images above are just a representation of the package family, actual package may vary.  
Refer to the product data sheet for package details.

4203482/L

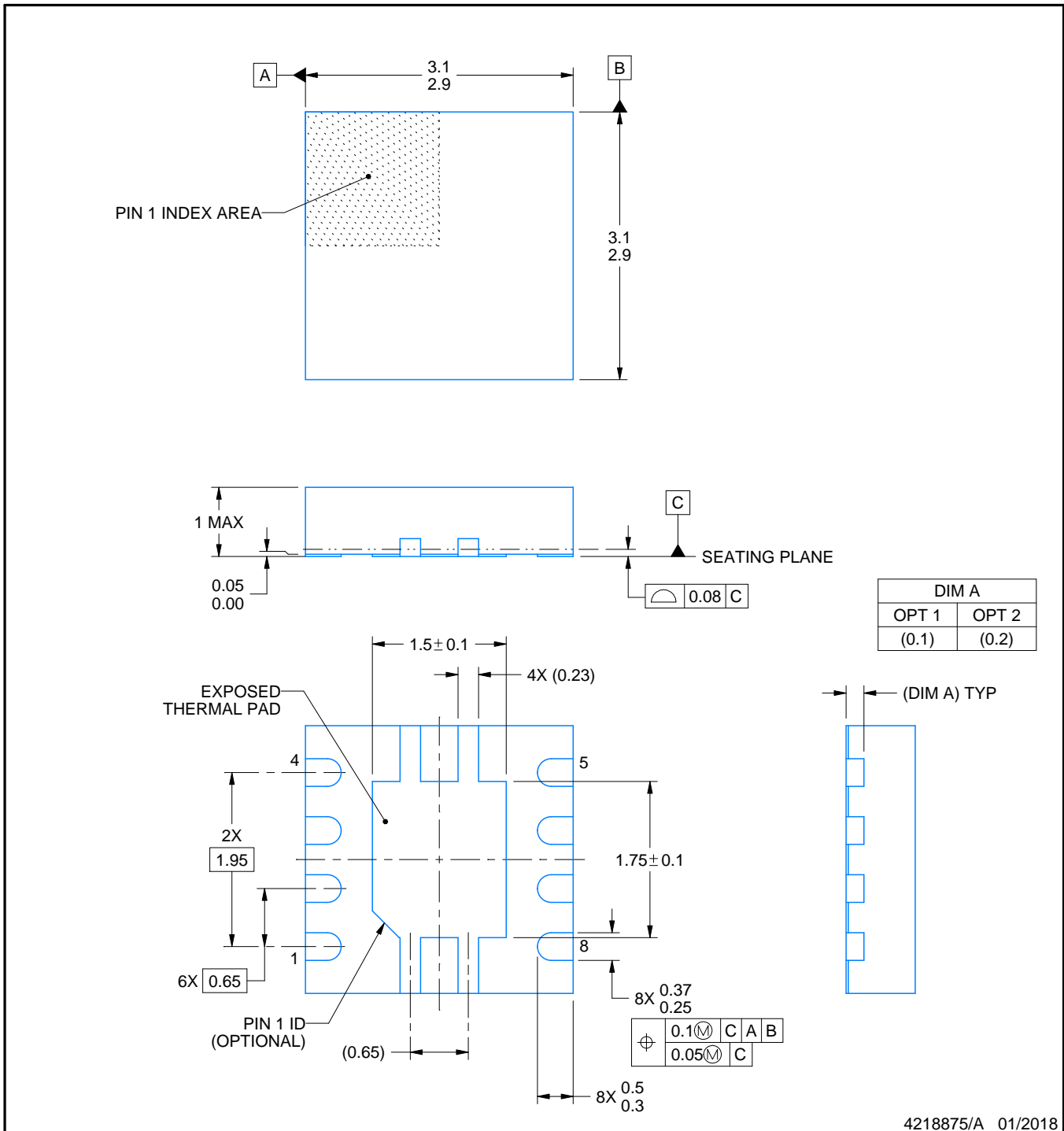

4218875/A 01/2018

NOTES:

1. All linear dimensions are in millimeters. Any dimensions in parenthesis are for reference only. Dimensioning and tolerancing per ASME Y14.5M.
2. This drawing is subject to change without notice.
3. The package thermal pad must be soldered to the printed circuit board for thermal and mechanical performance.

# EXAMPLE BOARD LAYOUT

DRB0008A

VSON - 1 mm max height

PLASTIC SMALL OUTLINE - NO LEAD



LAND PATTERN EXAMPLE  
EXPOSED METAL SHOWN  
SCALE:20X

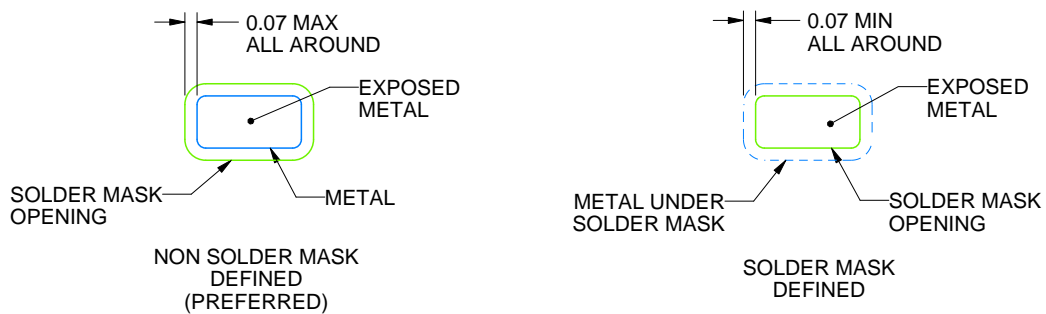

SOLDER MASK DETAILS

4218875/A 01/2018

NOTES: (continued)

4. This package is designed to be soldered to a thermal pad on the board. For more information, see Texas Instruments literature number SLUA271 ([www.ti.com/lit/slue271](http://www.ti.com/lit/slue271)).
5. Vias are optional depending on application, refer to device data sheet. If any vias are implemented, refer to their locations shown on this view. It is recommended that vias under paste be filled, plugged or tented.

# EXAMPLE STENCIL DESIGN

DRB0008A

VSON - 1 mm max height

PLASTIC SMALL OUTLINE - NO LEAD



SOLDER PASTE EXAMPLE  
BASED ON 0.125 mm THICK STENCIL

EXPOSED PAD  
84% PRINTED SOLDER COVERAGE BY AREA  
SCALE:25X

4218875/A 01/2018

NOTES: (continued)

6. Laser cutting apertures with trapezoidal walls and rounded corners may offer better paste release. IPC-7525 may have alternate design recommendations.





D0008A

# PACKAGE OUTLINE

SOIC - 1.75 mm max height

SMALL OUTLINE INTEGRATED CIRCUIT



4214825/C 02/2019

### NOTES:

1. Linear dimensions are in inches [millimeters]. Dimensions in parenthesis are for reference only. Controlling dimensions are in inches. Dimensioning and tolerancing per ASME Y14.5M.
2. This drawing is subject to change without notice.
3. This dimension does not include mold flash, protrusions, or gate burrs. Mold flash, protrusions, or gate burrs shall not exceed .006 [0.15] per side.
4. This dimension does not include interlead flash.
5. Reference JEDEC registration MS-012, variation AA.

# EXAMPLE BOARD LAYOUT

D0008A

SOIC - 1.75 mm max height

SMALL OUTLINE INTEGRATED CIRCUIT



LAND PATTERN EXAMPLE  
 EXPOSED METAL SHOWN  
 SCALE:8X



SOLDER MASK DETAILS

4214825/C 02/2019

NOTES: (continued)

- 6. Publication IPC-7351 may have alternate designs.
- 7. Solder mask tolerances between and around signal pads can vary based on board fabrication site.

# EXAMPLE STENCIL DESIGN

D0008A

SOIC - 1.75 mm max height

SMALL OUTLINE INTEGRATED CIRCUIT



SOLDER PASTE EXAMPLE  
BASED ON .005 INCH [0.125 MM] THICK STENCIL  
SCALE:8X

4214825/C 02/2019

NOTES: (continued)

8. Laser cutting apertures with trapezoidal walls and rounded corners may offer better paste release. IPC-7525 may have alternate design recommendations.
9. Board assembly site may have different recommendations for stencil design.

JG (R-GDIP-T8)

CERAMIC DUAL-IN-LINE

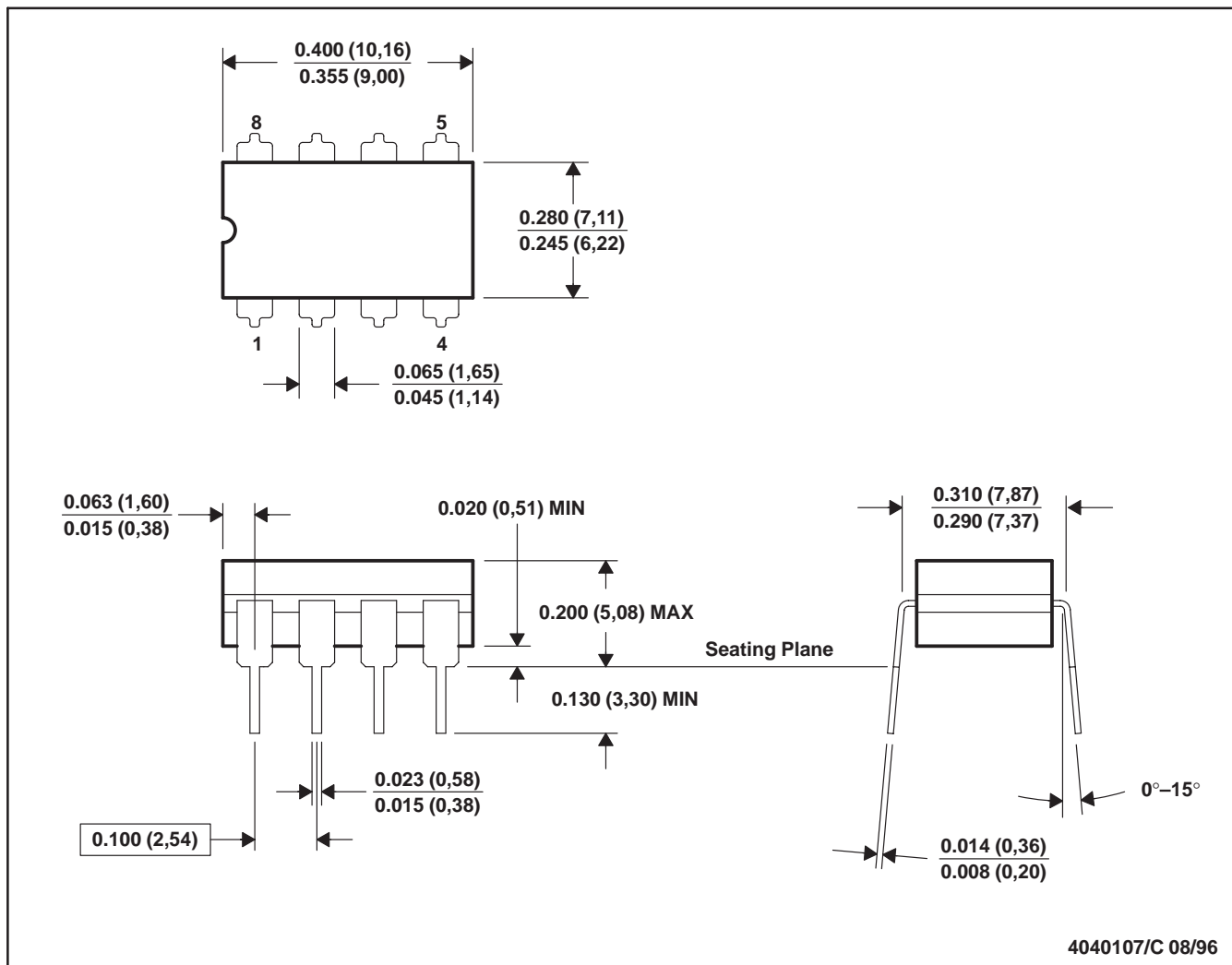

- NOTES: A. All linear dimensions are in inches (millimeters).  
 B. This drawing is subject to change without notice.  
 C. This package can be hermetically sealed with a ceramic lid using glass frit.  
 D. Index point is provided on cap for terminal identification.  
 E. Falls within MIL STD 1835 GDIP1-T8

P (R-PDIP-T8)

PLASTIC DUAL-IN-LINE PACKAGE

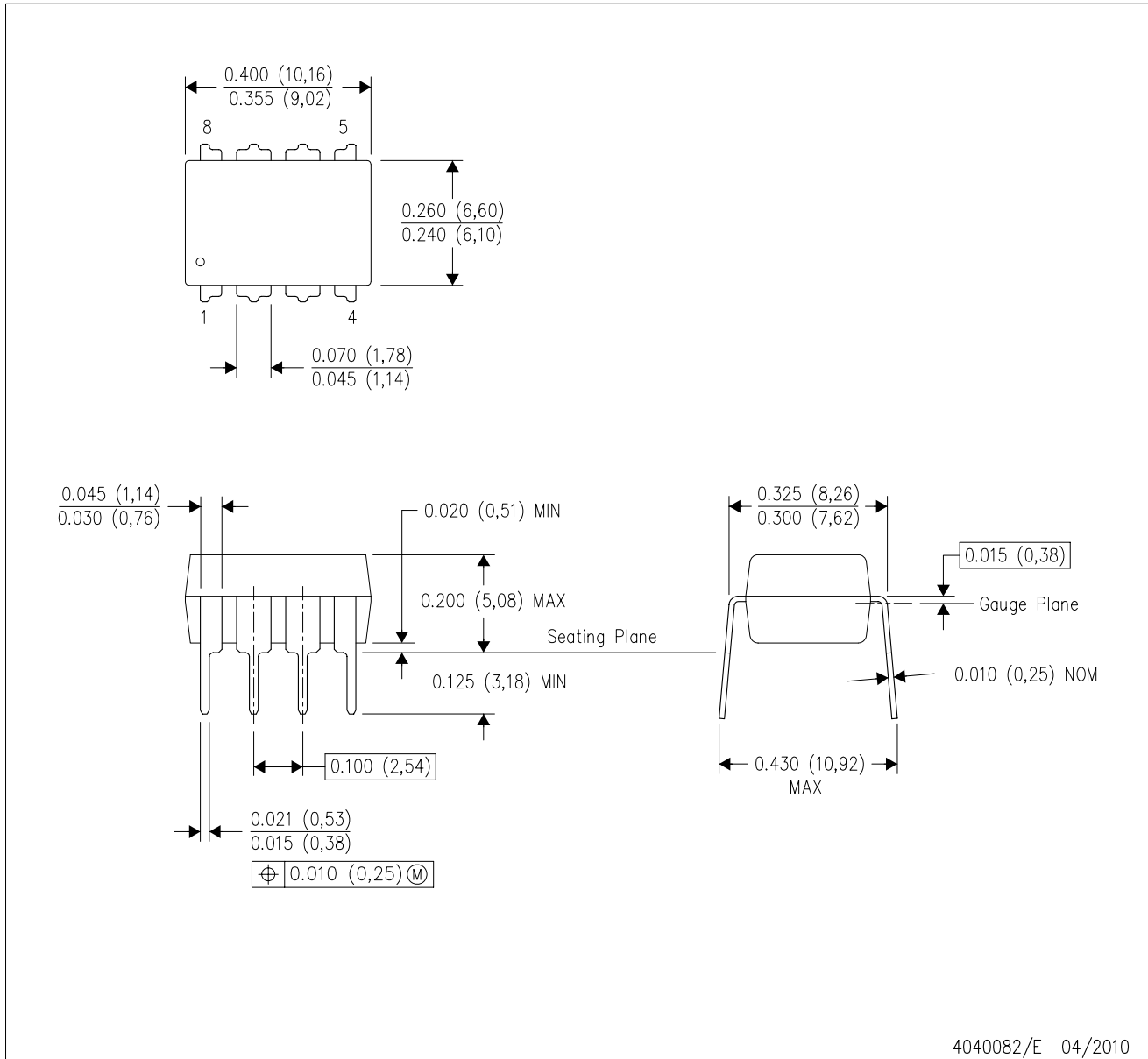

- NOTES:
- A. All linear dimensions are in inches (millimeters).
  - B. This drawing is subject to change without notice.
  - C. Falls within JEDEC MS-001 variation BA.



# EXAMPLE BOARD LAYOUT

PW0008A

TSSOP - 1.2 mm max height

SMALL OUTLINE PACKAGE



LAND PATTERN EXAMPLE  
SCALE:10X



SOLDER MASK DETAILS  
NOT TO SCALE

4221848/A 02/2015

NOTES: (continued)

- 6. Publication IPC-7351 may have alternate designs.
- 7. Solder mask tolerances between and around signal pads can vary based on board fabrication site.

# EXAMPLE STENCIL DESIGN

PW0008A

TSSOP - 1.2 mm max height

SMALL OUTLINE PACKAGE



SOLDER PASTE EXAMPLE  
BASED ON 0.125 mm THICK STENCIL  
SCALE:10X

4221848/A 02/2015

NOTES: (continued)

8. Laser cutting apertures with trapezoidal walls and rounded corners may offer better paste release. IPC-7525 may have alternate design recommendations.
9. Board assembly site may have different recommendations for stencil design.

## IMPORTANT NOTICE AND DISCLAIMER

TI PROVIDES TECHNICAL AND RELIABILITY DATA (INCLUDING DATASHEETS), DESIGN RESOURCES (INCLUDING REFERENCE DESIGNS), APPLICATION OR OTHER DESIGN ADVICE, WEB TOOLS, SAFETY INFORMATION, AND OTHER RESOURCES "AS IS" AND WITH ALL FAULTS, AND DISCLAIMS ALL WARRANTIES, EXPRESS AND IMPLIED, INCLUDING WITHOUT LIMITATION ANY IMPLIED WARRANTIES OF MERCHANTABILITY, FITNESS FOR A PARTICULAR PURPOSE OR NON-INFRINGEMENT OF THIRD PARTY INTELLECTUAL PROPERTY RIGHTS.

These resources are intended for skilled developers designing with TI products. You are solely responsible for (1) selecting the appropriate TI products for your application, (2) designing, validating and testing your application, and (3) ensuring your application meets applicable standards, and any other safety, security, or other requirements. These resources are subject to change without notice. TI grants you permission to use these resources only for development of an application that uses the TI products described in the resource. Other reproduction and display of these resources is prohibited. No license is granted to any other TI intellectual property right or to any third party intellectual property right. TI disclaims responsibility for, and you will fully indemnify TI and its representatives against, any claims, damages, costs, losses, and liabilities arising out of your use of these resources.

TI's products are provided subject to TI's Terms of Sale ([www.ti.com/legal/termsofsale.html](http://www.ti.com/legal/termsofsale.html)) or other applicable terms available either on [ti.com](http://ti.com) or provided in conjunction with such TI products. TI's provision of these resources does not expand or otherwise alter TI's applicable warranties or warranty disclaimers for TI products.

Mailing Address: Texas Instruments, Post Office Box 655303, Dallas, Texas 75265  
Copyright © 2019, Texas Instruments Incorporated

## Looking for pricing, stock, or lifecycle information?

Click below to explore more details on WIN SOURCE:

 [View TLC7701IPW on WIN SOURCE](#)

 [Texas Instruments](#) Information

## Optimize Your Supply Chain with WIN SOURCE Solutions

-  Global Sourcing Solution
-  Obsolete Management
-  Cost Control Management
-  Shortage Management
-  Alternative Solution
-  Excess Inventory Management