

OPTIREG™ Linear TLE4269

5 V low drop fixed voltage regulator



Features

- Output voltage tolerance $\leq \pm 2\%$
- 150 mA current capability
- Very low current consumption
- Early warning
- Reset output low down to $V_Q = 1\text{ V}$
- Overtemperature protection
- Reverse polarity proof
- Adjustable reset threshold
- Very low drop voltage
- Wide temperature range
- Integrated pull-up resistor at logic outputs
- Green Product (RoHS compliant)

Potential applications

General automotive applications.

Product validation

Qualified for automotive applications. Product validation according to AEC-Q100/101.

Description

The OPTIREG™ Linear TLE4269 is an automotive voltage regulator with a 5 V fixed output. The maximum operating voltage is 45 V. The output is able to drive 150 mA load. The device features short-circuit protection. The thermal shutdown feature switches the output off when the junction temperature exceeds 150°C to ensure the device is not damaged by overheating. A reset signal is generated when the output voltage drops below $V_Q < 4.65\text{ V}$. The reset threshold voltage can be decreased by an external connection of a voltage divider. The reset delay time can be set by an external capacitor. Reset and sense output have integrated pull-up resistors. If the integrated resistors are not required, the TLE4279 can be used instead. It is also possible to supervise the input voltage by using an integrated comparator to give a low voltage warning.

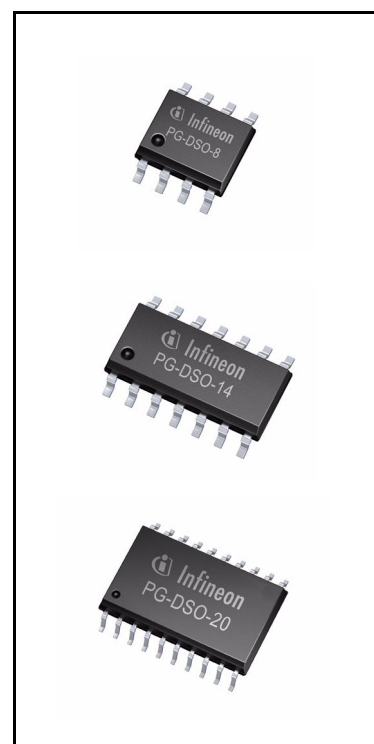

Type	Package	Marking
TLE4269G	PG-DSO-8	TLE 4269
TLE4269GM	PG-DSO-14	TLE 4269
TLE4269GL	PG-DSO-20	TLE 4269

Table of contents

	Features	1
	Potential applications	1
	Product validation	1
	Description	1
	Table of contents	2
1	Block diagram	3
2	Pin configuration	4
3	General product characteristics	7
3.1	Absolute maximum ratings	7
3.2	Electrical characteristics	9
4	Functional description	10
5	Application information	11
5.1	Application diagram	11
5.2	Typical performance characteristics	13
6	Package information	16
7	Revision history	18

Block diagram

1 Block diagram

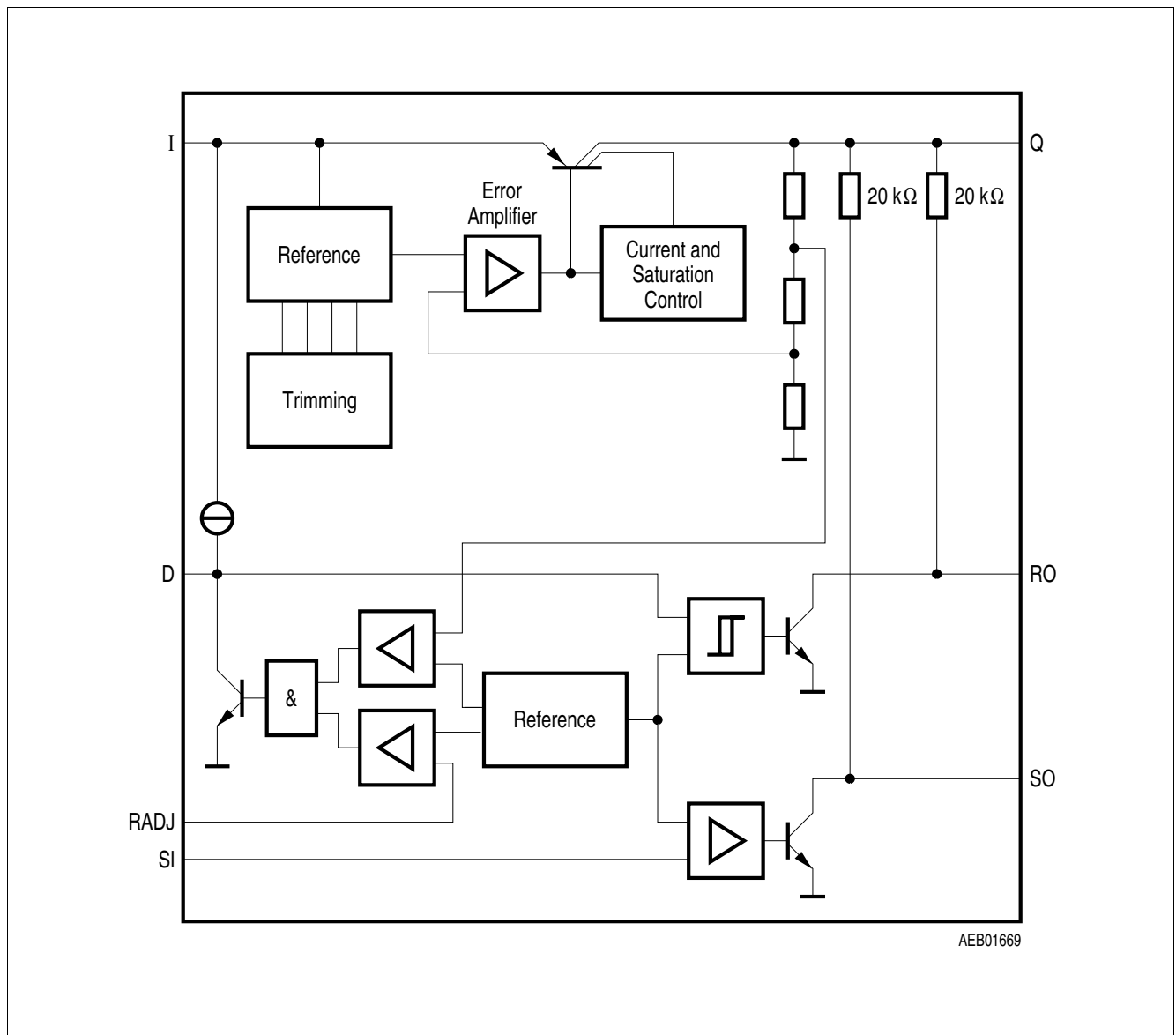

Figure 1 Block diagram

Pin configuration

2 Pin configuration

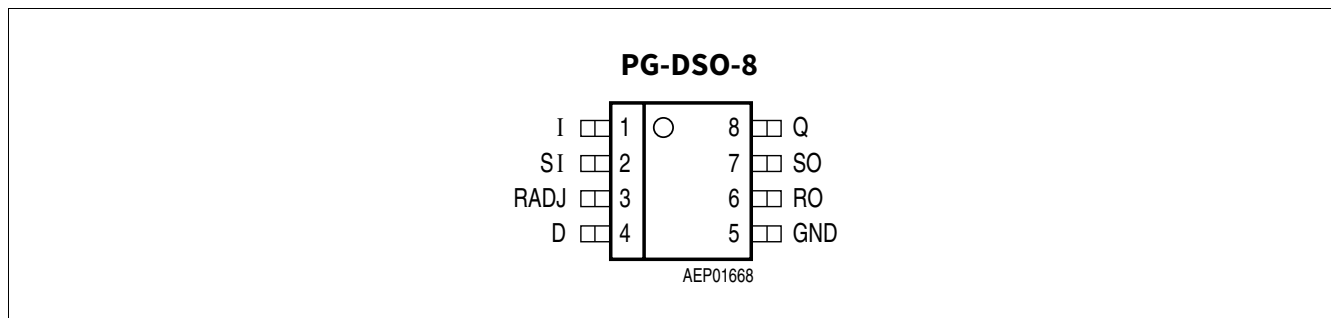

Figure 2 Pin configuration PG-DSO-8 (top view)

Table 1 Pin definitions and functions (TLE4269G)

Pin No.	Symbol	Function
1	I	Input connected with a ceramic capacitor to GND directly at the IC.
2	SI	Sense input if not needed connect to Q.
3	RADJ	Reset threshold adjust if not needed connect to GND.
4	D	Reset delay to select delay time, connect to GND via capacitor.
5	GND	Ground
6	RO	Reset output the open collector output is connected to the 5 V output via an integrated 20 kΩ pull-up resistor; leave open if the reset function is not needed
7	SO	Sense output the open collector output is connected to the 5 V output via an integrated 20 kΩ pull-up resistor; leave open if the sense comparator is not needed.
8	Q	5 V output connect to GND with a 10 μF capacitor, ESR < 10 Ω

Pin configuration

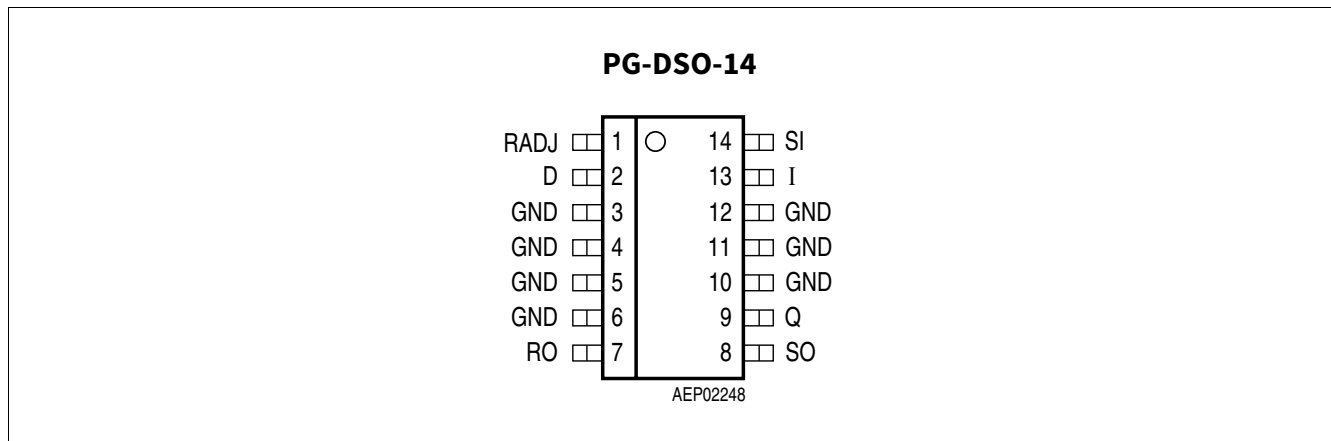

Figure 3 Pin configuration PG-DSO-14 (top view)

Table 2 Pin definitions and functions (TLE4269GM)

Pin No.	Symbol	Function
1	RADJ	Reset threshold adjust if not needed connect to GND.
2	D	Reset delay to select delay time; connect to GND via capacitor.
3, 4, 5, 6	GND	Ground
7	RO	Reset output the open collector output is connected to the 5 V output via an integrated 20 kΩ pull-up resistor; leave open if the reset function is not needed
8	SO	Sense output the open collector output is connected to the 5 V output via an integrated 20 kΩ pull-up resistor; leave open if the sense comparator is not needed.
9	Q	5 V Output connect to GND with a 10 μF capacitor, ESR < 10 Ω.
10, 11, 12	GND	Ground
13	I	Input connected with a ceramic capacitor to GND directly at the IC.
14	SI	Sense input if not needed connect to Q.

Pin configuration

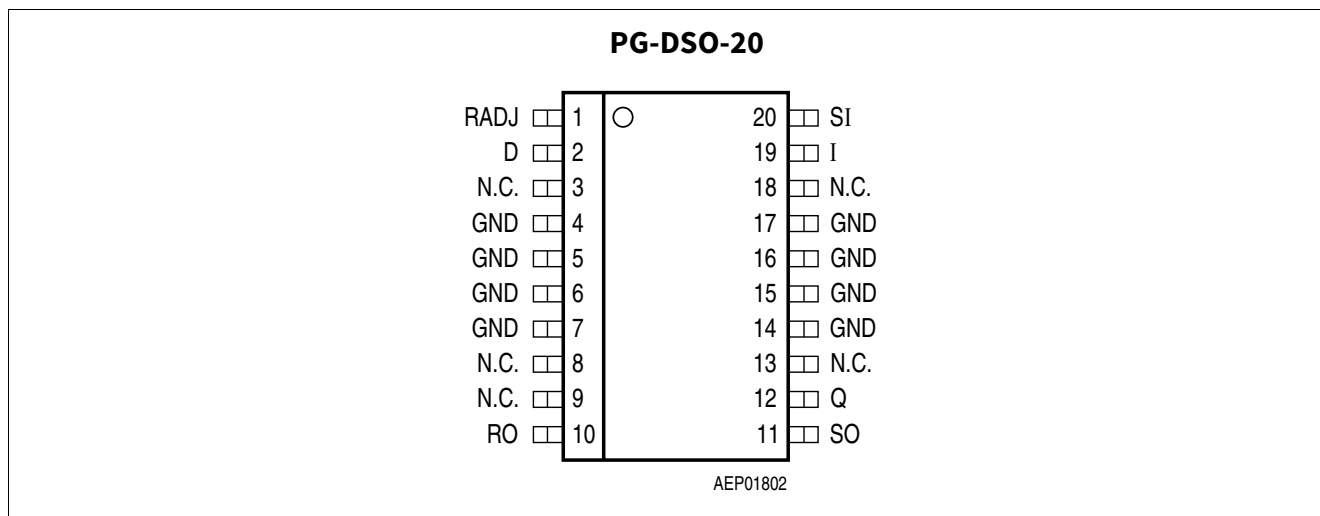

Figure 4 Pin configuration PG-DSO-20 (top view)

Table 3 Pin definitions and functions (TLE4269GL)

Pin No.	Symbol	Function
1	RADJ	Reset threshold adjust if not needed connect to ground.
2	D	Reset delay to select delay time, connect to GND via external capacitor.
4 - 7, 14 - 17	GND	Ground
10	RO	Reset output the open collector output is connected to the 5 V output via an integrated 20 kΩ pull-up resistor; leave open if the reset function is not needed
11	SO	Sense output the open collector output is connected to the 5 V output via an integrated 20 kΩ pull-up resistor; leave open if the sense comparator is not needed.
12	Q	Output connect to GND with a 10 μF capacitor, ESR < 10 Ω.
19	I	Input connected with a ceramic capacitor to GND directly at the IC.
20	SI	Sense input if not needed connect to Q.

General product characteristics

3 General product characteristics

3.1 Absolute maximum ratings

Table 4 Absolute maximum ratings

$T_j = -40^\circ\text{C}$ to 150°C

Parameter	Symbol	Values			Unit	Note or Test Condition
		Min.	Typ.	Max.		
Input						
Input voltage	V_I	-40	–	45	V	–
Input current	I_I	–	–	–	–	Internal limited
Sense input						
Input voltage	V_{SI}	-40	–	45	V	–
Input current	I_{SI}	1	–	1	mA	–
Reset threshold						
Voltage	V_{RADJ}	-0.3	–	7	V	–
Current	I_{RADJ}	-10	–	10	mA	–
Reset delay						
Voltage	V_D	-0.3	–	7	V	–
Current	I_D	–	–	–	–	Internal limited
Ground						
Current	I_{GND}	50	–	–	mA	–
Reset output						
Voltage	V_R	-0.3	–	7	V	–
Current	I_R	–	–	–	–	Internal limited
Sense output						
Voltage	V_{SO}	-0.3	–	7	V	–
Current	I_{SO}	–	–	–	–	Internal limited
5 V output						
Output voltage	V_Q	-0.5	–	7	V	–
Output current	I_Q	-10	–	–	mA	–
Temperature						
Junction temperature	T_j	–	–	150	$^\circ\text{C}$	–
Storage temperature	T_{Stg}	-50	–	150	$^\circ\text{C}$	–
Operating range						
Input voltage	V_I	–	–	45	V	–
Junction temperature	T_j	-40	–	150	$^\circ\text{C}$	–

General product characteristics

Table 4 Absolute maximum ratings (cont'd)

$T_j = -40^\circ\text{C}$ to 150°C

Parameter	Symbol	Values			Unit	Note or Test Condition
		Min.	Typ.	Max.		
Thermal data						
Junction-ambient	R_{thja}	–	–	200	K/W	PG-DSO-8
		–	–	70	K/W	PG-DSO-14
		–	–	70	K/W	PG-DSO-20
Junction-pin	R_{thjp}	–	–	30	K/W	PG-DSO-8 ¹⁾
		–	–	30	K/W	PG-DSO-14 ²⁾
		–	–	30	K/W	PG-DSO-20 ²⁾

1) Measured to pin 5.

2) Measured to pin 4.

General product characteristics

3.2 Electrical characteristics

Table 5 Electrical characteristics

$V_I = 13.5\text{ V}$; $-40^\circ\text{C} \leq T_j \leq 125^\circ\text{C}$

Parameter	Symbol	Values			Unit	Note or Test Condition
		Min.	Typ.	Max.		
Output voltage	V_Q	4.90	5.00	5.10	V	$1\text{ mA} \leq I_Q \leq 100\text{ mA}$, $6\text{ V} \leq V_I \leq 16\text{ V}$
Current limit	I_Q	150	200	500	mA	–
Current consumption; $I_q = I_I - I_Q$	I_q	–	240	300	μA	$I_Q \leq 1\text{ mA}$, $T_j < 85^\circ\text{C}$
Current consumption; $I_q = I_I - I_Q$	I_q	–	250	700	μA	$I_Q = 10\text{ mA}$
Current consumption; $I_q = I_I - I_Q$	I_q	–	2	8	mA	$I_Q = 50\text{ mA}$
Drop voltage	V_{dr}	–	0.25	0.5	V	$I_Q = 100\text{ mA}^{1)}$
Load regulation	ΔV_Q	–	10	30	mV	$I_Q = 5\text{ mA}$ to 100 mA
Line regulation	ΔV_Q	–	10	40	mV	$V_I = 6\text{ V}$ to 26 V , $I_Q = 1\text{ mA}$

Reset generator

Switching threshold	V_{RT}	4.50	4.65	4.80	V	–
Reset adjust switching threshold	$V_{RADJ, TH}$	1.26	1.35	1.44	V	$V_Q > 3.5\text{ V}$
Reset pull-up	–	10	20	40	k Ω	–
Saturation voltage	$V_{RO, SAT}$	–	0.1	0.4	V	R_{intern}
Upper delay switching threshold	V_{UD}	1.4	1.8	2.2	V	–
Lower delay switching threshold	V_{LD}	0.3	0.45	0.60	V	–
Saturation voltage delay capacitor	$V_{D, SAT}$	–	–	0.1	V	$V_Q < V_{RT}$
Charge current	I_D	3.0	6.5	9.5	μA	$V_D = 1\text{ V}$
Delay time L \rightarrow H	t_d	17	28	–	ms	$C_D = 100\text{ nF}$
Delay time H \rightarrow L	t_t	–	1	–	μs	$C_D = 100\text{ nF}$

Input voltage sense

Sense threshold high	$V_{SI, high}$	1.24	1.31	1.38	V	–
Sense threshold low	$V_{SI, low}$	1.16	1.20	1.28	V	–
Sense output low voltage	$V_{SO, low}$	–	0.1	0.4	V	$V_{SI} < 1.20\text{ V}$; $V_Q > 3\text{ V}$, R_{intern}
Sense pull-up	–	10	20	40	k Ω	–
Sense input current	I_{SI}	-1	0.1	1	μA	–

1) Drop voltage = $V_I - V_Q$ measured when the output voltage has dropped 100 mV from the nominal value obtained at 13.5 V input.

Functional description

4 Functional description

The control amplifier compares a reference voltage, made highly accurate by resistance balancing, with a voltage proportional to the output voltage and drives the base of the series PNP transistor via a buffer. Saturation control as a function of the load current prevents any over-saturation of the power element.

The reset output RO is in high-state if the voltage on the delay capacitor C_D is greater or equal V_{UD} . The delay capacitor C_D is charged with the current I_D for output voltages greater than the reset threshold V_{RT} . If the output voltage gets lower than V_{RT} ('reset condition') a fast discharge of the delay capacitor C_D sets in and as soon as V_D gets lower than V_{LD} the reset output RO is set to low-level.

The time gap for the delay capacitor discharge is the reset reaction time t_{RR} .

The reset threshold V_{RT} can be decreased via an external voltage divider connected to the pin RADJ. In this case the reset condition is reached if $V_Q < V_{RT}$ and $V_{RADJ} < V_{RAQDJ, TH}$. Dimensioning the voltage divider (**Figure 5**) according to:

(4.1)

$$V_{THRES} = \frac{V_{RAD(J, TH)} \times (R_{ADJ1} + R_{ADJ2})}{R_{ADJ2}}$$

the reset threshold can be decreased down to 3.5 V. If the reset-adjust-option is not needed the RADJ-pin should be connected to GND causing the reset threshold to go to its default value (typ. 4.65 V).

A built in comparator compares the signal of the pin SI, normally fed by a voltage divider from the input voltage, with the reference and gives an early warning on the pin SO. It is also possible to superwise another voltage e.g. of a second regulator, or to build a watchdog circuit with few external components.

Application information

5 Application information

The input capacitor C_I is necessary for compensating line influences. Using a resistor of approx. $1\ \Omega$ in series with C_I , the oscillating circuit consisting of input inductivity and input capacitance can be damped. The output capacitor C_Q is necessary for the stability of the regulating circuit. Stability is guaranteed at values $\geq 10\ \mu\text{F}$ and an $\text{ESR} \leq 10\ \Omega$ within the operating temperature range. For small tolerances of the reset delay the spread of the capacitance of the delay capacitor and its temperature coefficient should be noted.

5.1 Application diagram

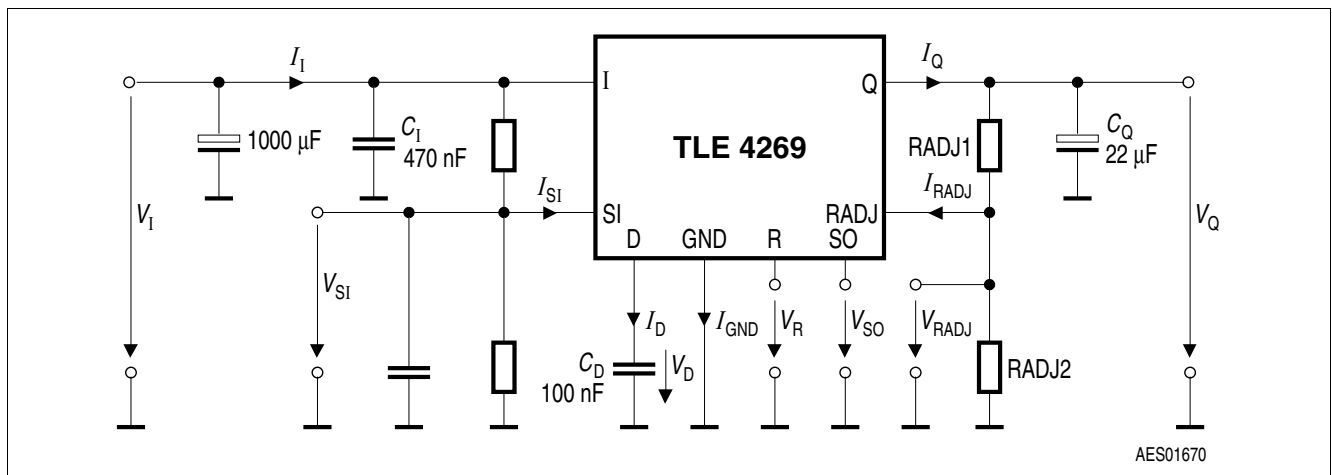

Figure 5 Measuring circuit

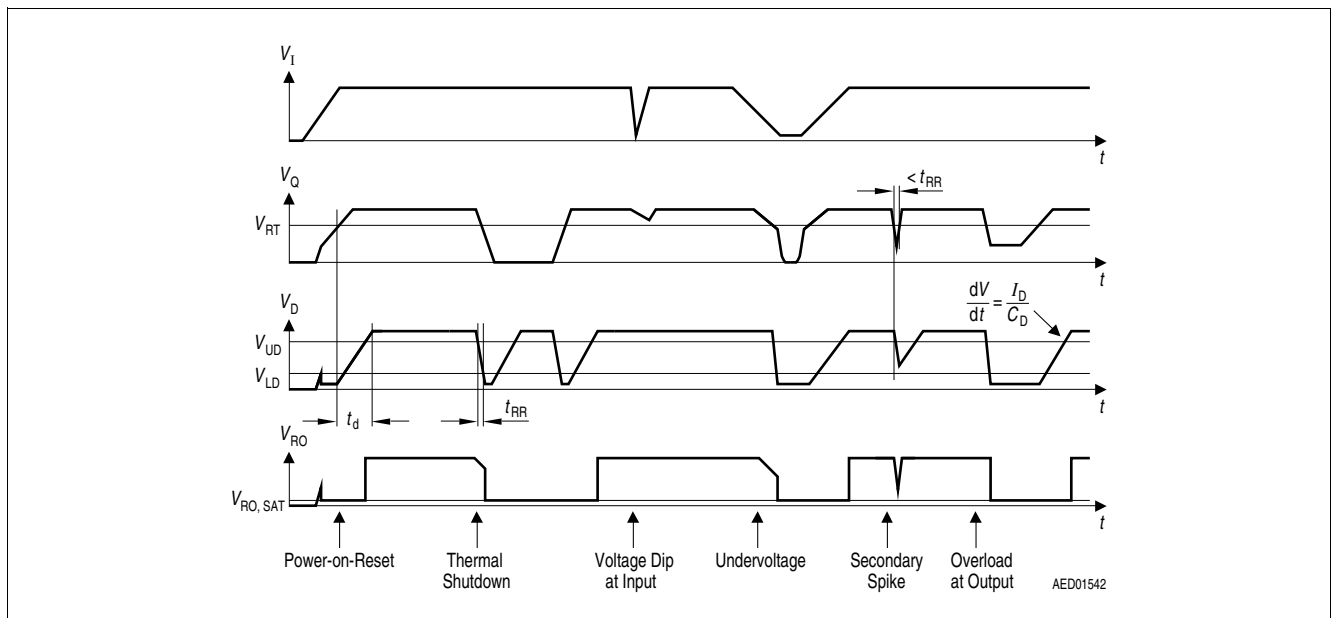

Figure 6 Reset timing diagram

Application information

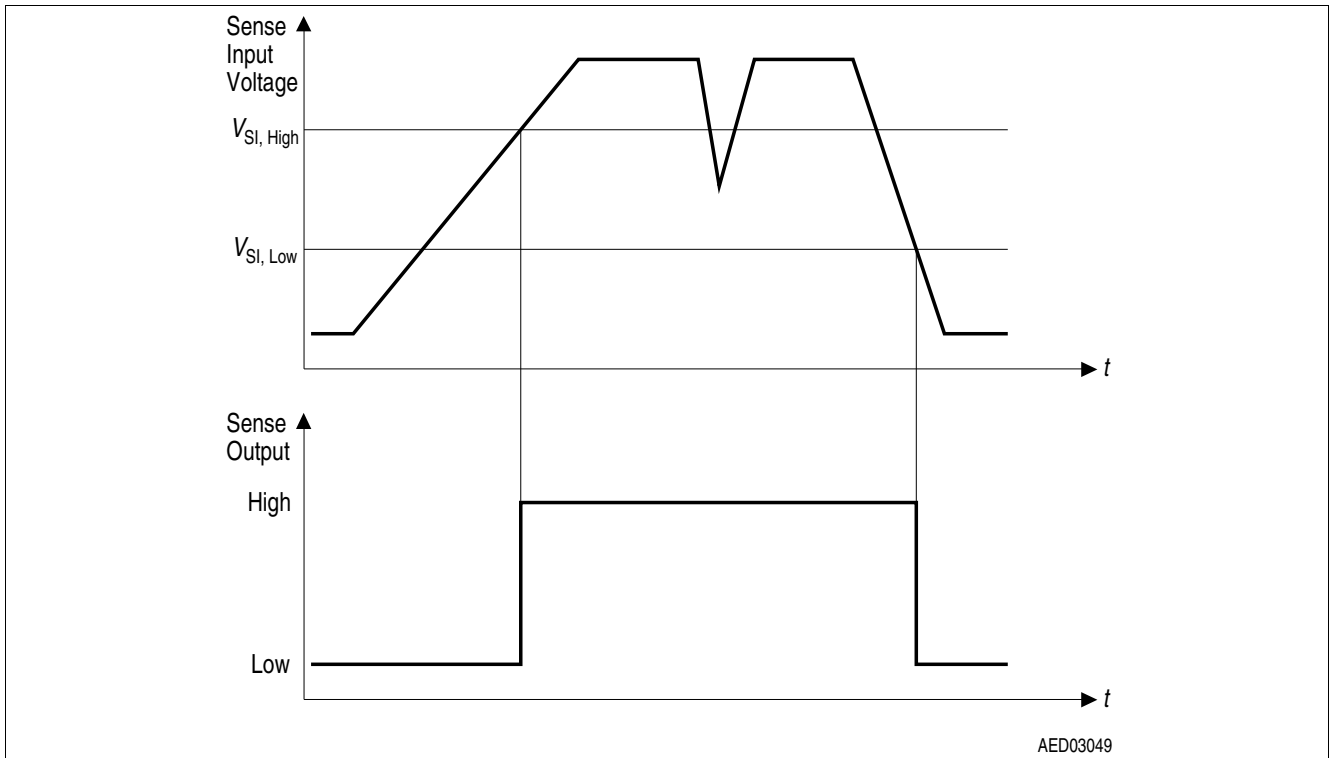
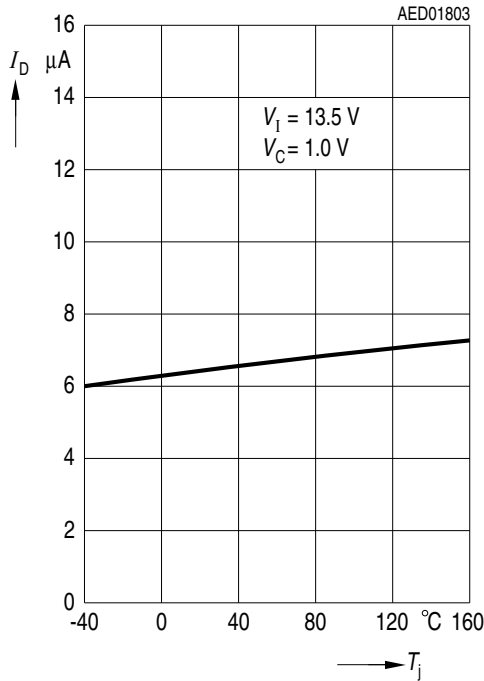

Figure 7 Sense timing diagram

Application information

5.2 Typical performance characteristics

Charge current I_D versus junction temperature T_j



Switching voltage V_{UD} and V_{LD} versus junction temperature T_j

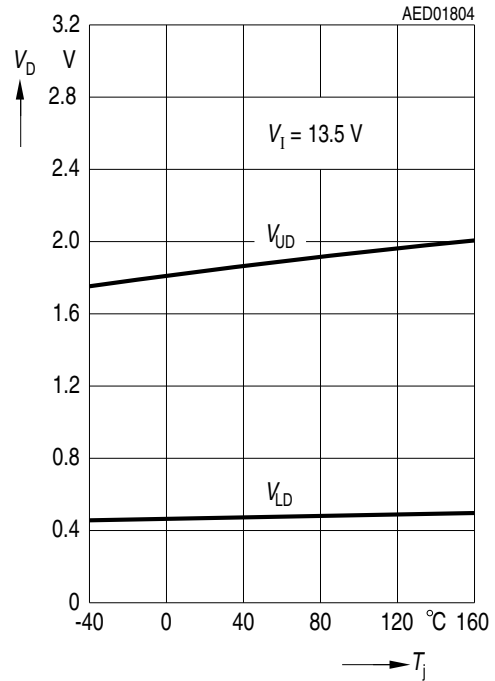

Drop voltage V_{dr} versus output current I_Q

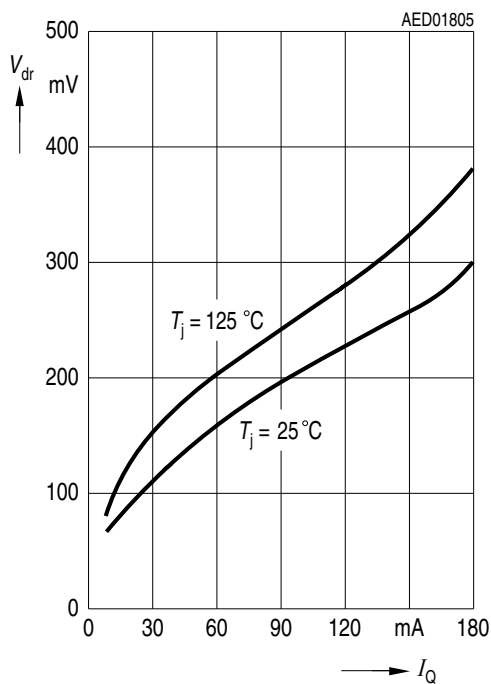

Reset adjust switching threshold $V_{RADJ,TH}$ versus junction temperature T_j

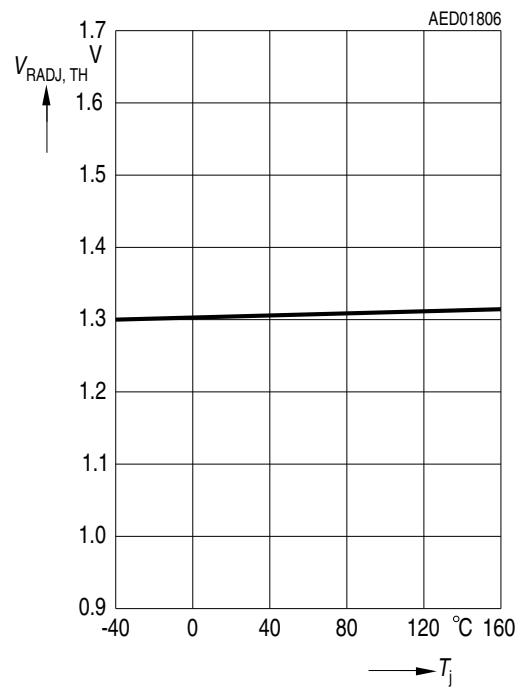

Application information

Current consumption I_Q versus input voltage V_I

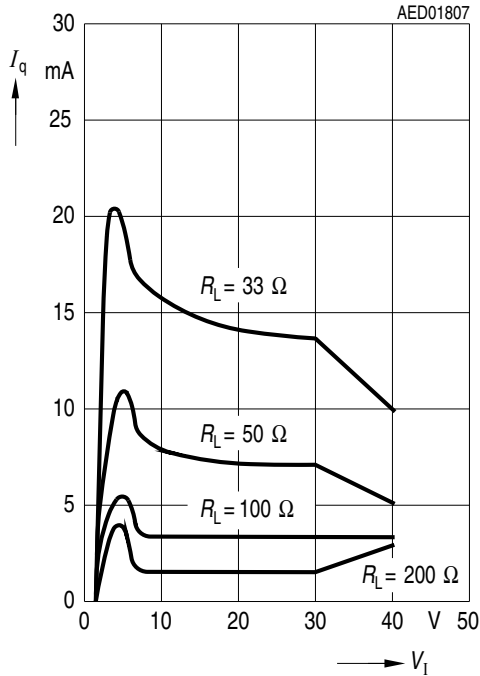

Output voltage V_Q versus input voltage V_I

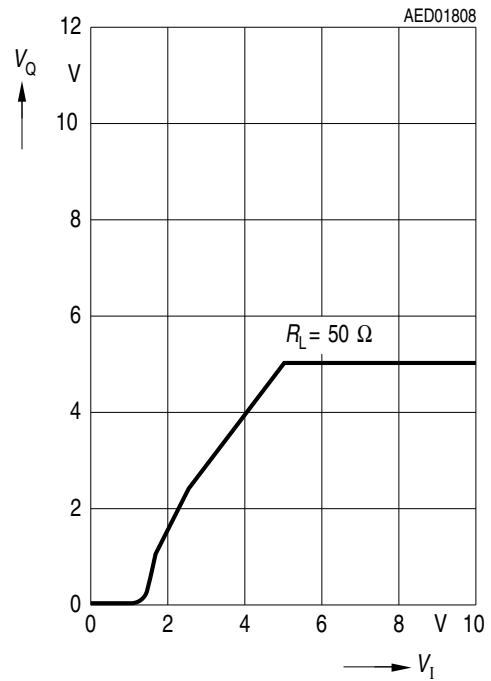

Sense threshold V_{SI} versus junction temperature T_j

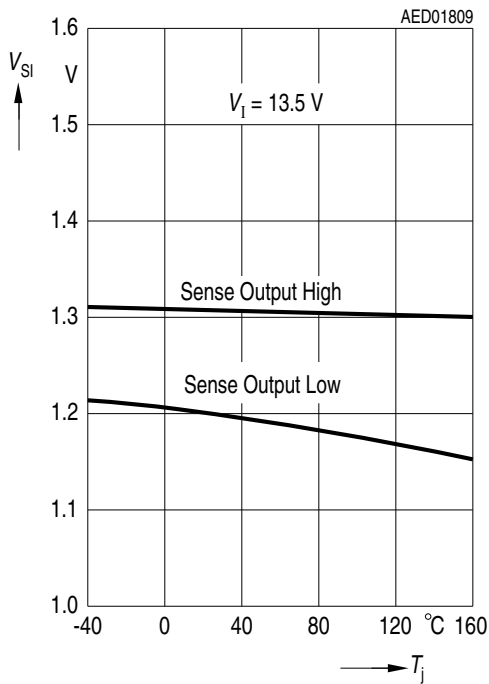

Output voltage V_Q versus junction temperature T_j

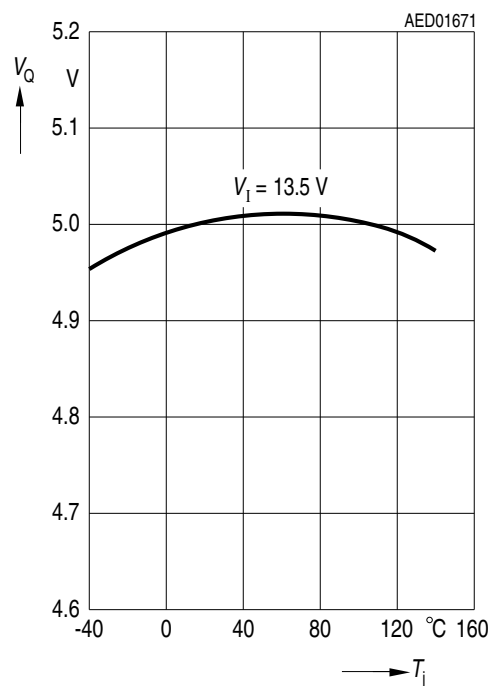

Application information

Output current I_Q versus input voltage V_I

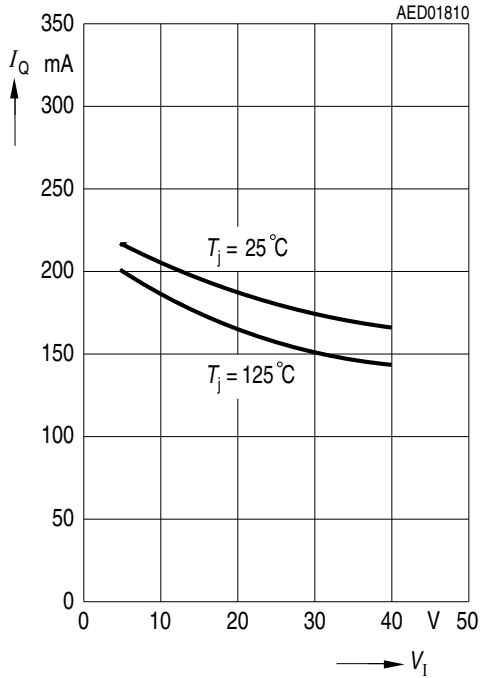

Current consumption I_q versus output current I_Q

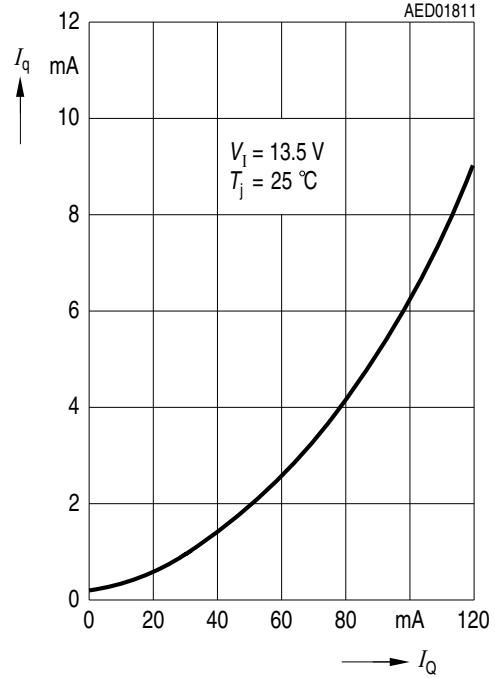

Current consumption I_q versus output current I_Q

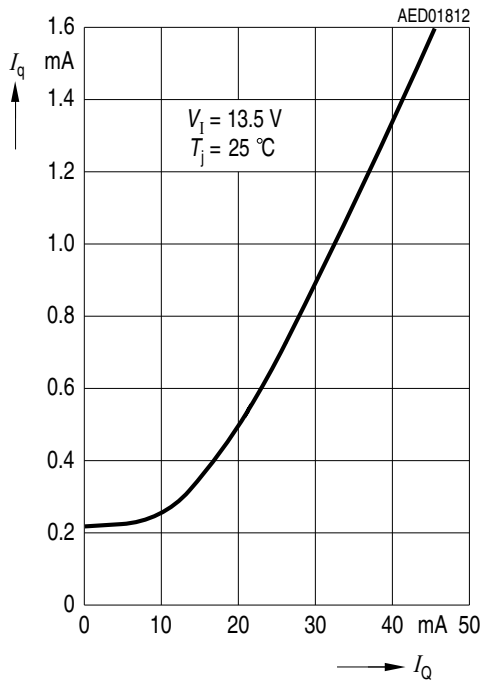

Package information

6 Package information

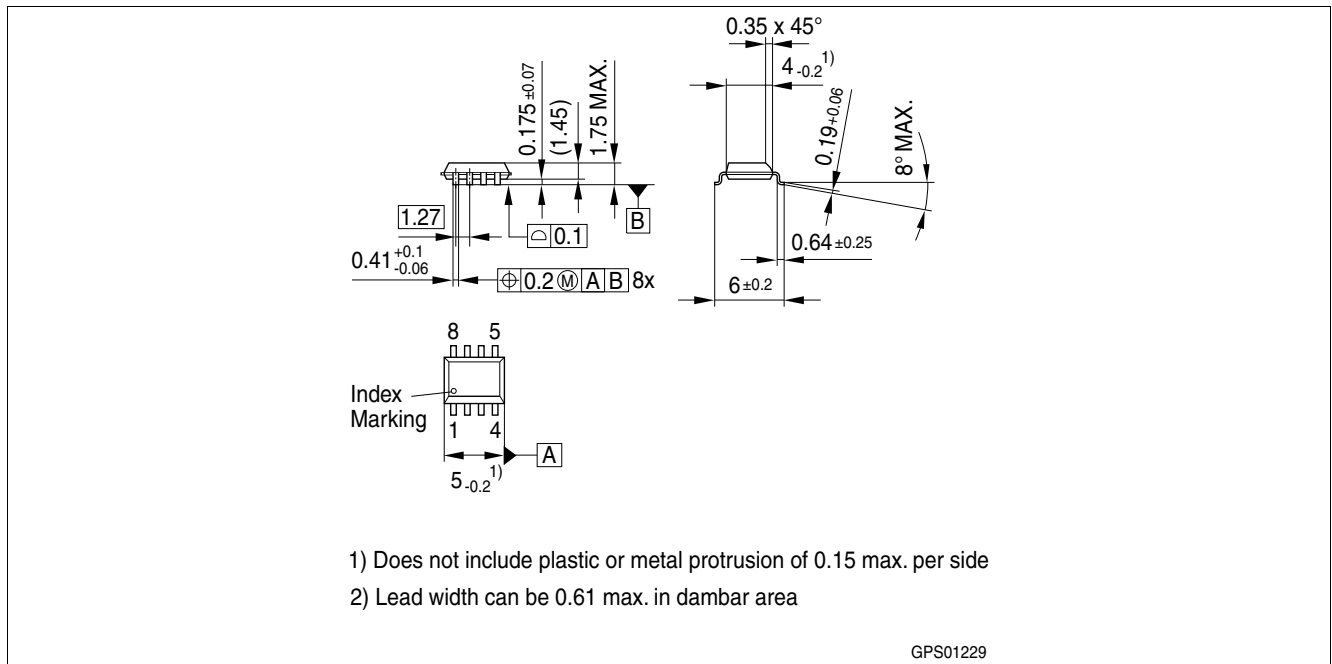

Figure 8 PG-DSO-8¹⁾

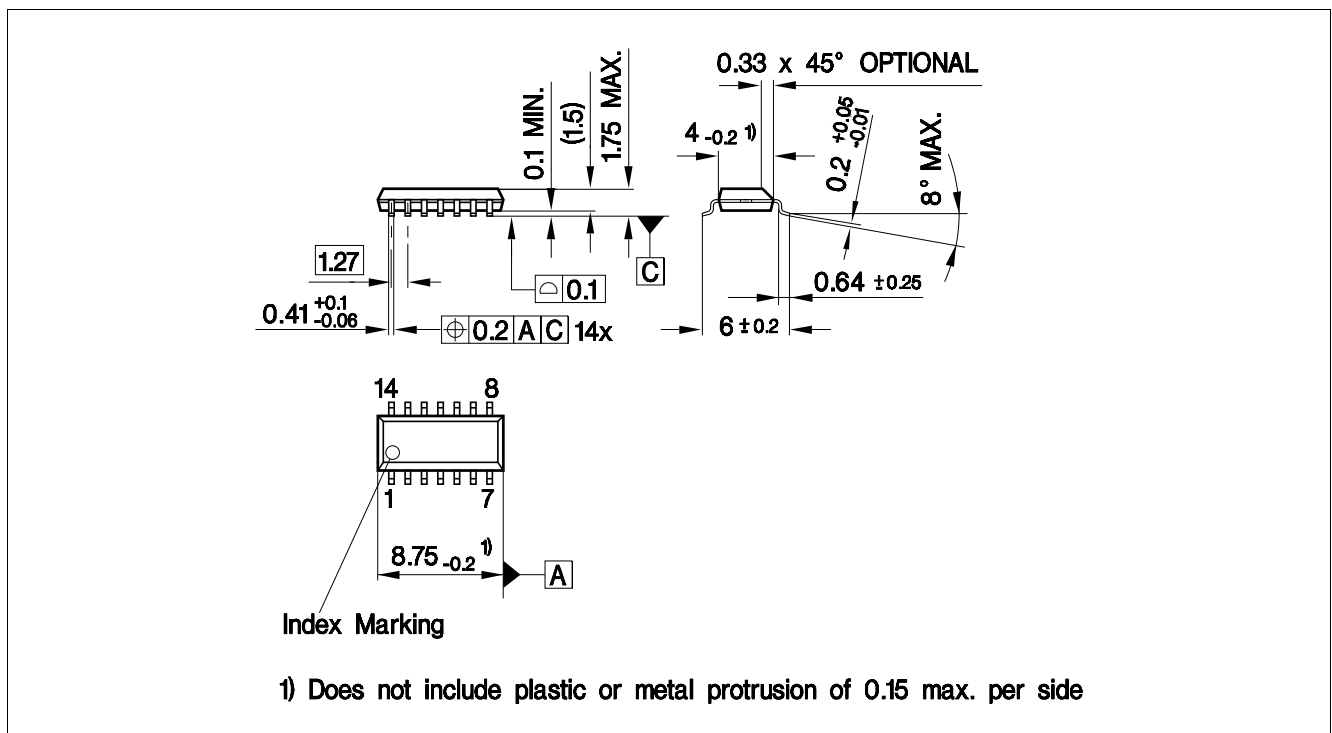

Figure 9 PG-DSO-14¹⁾

1) Dimensions in mm

Revision history

7 Revision history

Revision	Date	Changes
2.6	2018-11-20	Update layout and structure Updated packaged drawing “PG-DSO-14” Editorial changes
2.5	2013-11-25	Package version changed: - PG-DSO-20-35 to PG-DSO-20 Package naming harmonized according to Infineon standards: - PG-DSO-8-16 to PG-DSO-8 - PG-DSO-14-30 to PG-DSO-14
2.4	2007-03-20	Initial version of RoHS-compliant derivate of TLE4269 Page 1 : AEC certified statement added Page 1 and Page 16 : RoHS compliance statement and Green product feature added Page 1 and Page 16 : Package changed to RoHS compliant version Legal Disclaimer updated
2.3	2004-01-01	

Trademarks

All referenced product or service names and trademarks are the property of their respective owners.

Edition 2018-11-20

Published by

Infineon Technologies AG

81726 Munich, Germany

© 2018 Infineon Technologies AG.

All Rights Reserved.

Do you have a question about any aspect of this document?

Email: erratum@infineon.com

Document reference

Z8F52238104

IMPORTANT NOTICE

The information given in this document shall in no event be regarded as a guarantee of conditions or characteristics ("Beschaffheitsgarantie").

With respect to any examples, hints or any typical values stated herein and/or any information regarding the application of the product, Infineon Technologies hereby disclaims any and all warranties and liabilities of any kind, including without limitation warranties of non-infringement of intellectual property rights of any third party.

In addition, any information given in this document is subject to customer's compliance with its obligations stated in this document and any applicable legal requirements, norms and standards concerning customer's products and any use of the product of Infineon Technologies in customer's applications.

The data contained in this document is exclusively intended for technically trained staff. It is the responsibility of customer's technical departments to evaluate the suitability of the product for the intended application and the completeness of the product information given in this document with respect to such application.

For further information on technology, delivery terms and conditions and prices, please contact the nearest Infineon Technologies Office (www.infineon.com).

WARNINGS

Due to technical requirements products may contain dangerous substances. For information on the types in question please contact your nearest Infineon Technologies office.

Except as otherwise explicitly approved by Infineon Technologies in a written document signed by authorized representatives of Infineon Technologies, Infineon Technologies' products may not be used in any applications where a failure of the product or any consequences of the use thereof can reasonably be expected to result in personal injury.

Looking for pricing, stock, or lifecycle information?

Click below to explore more details on WIN SOURCE:

- ⊖ [View TLE4269G on WIN SOURCE](#)
- ⊖ [Infineon Technologies Information](#)

Optimize Your Supply Chain with WIN SOURCE Solutions

- ✓ Global Sourcing Solution
- ✓ Obsolete Management
- ✓ Cost Control Management
- ✓ Shortage Management
- ✓ Alternative Solution
- ✓ Excess Inventory Management