

TLF80511

Low Dropout Linear Fixed Voltage Regulator

TLF80511TC

Data Sheet

Rev. 1.01, 2016-06-21

Automotive Power



1 Overview

Features

- Output Voltage 5 V
- Output Voltage Precision $\pm 2\%$
- Output Current up to 400 mA
- Ultra Low Current Consumption 38 μA
- Very Low Dropout Voltage: 100 mV at 100 mA Output Current
- Extended Operating Range Starting at 3.3 V
- Small Output Capacitor 1 μF
- Output Current Limitation
- Overtemperature Shutdown
- Suitable for Use in Automotive Electronics
- Wide Temperature Range from $-40\text{ }^\circ\text{C}$ up to $150\text{ }^\circ\text{C}$
- Green Product (RoHS compliant)
- AEC Qualified



PG-TO263-3

Description

The TLF80511 is a linear low dropout voltage regulator for load currents up to 400 mA. An input voltage of up to 40 V is regulated to $V_{Q,nom} = 5\text{ V}$ with $\pm 2\%$ precision.

The TLF80511 with a typical quiescent current of 38 μA , is the ideal solution for systems requiring very low operating currents, such as those permanently connected to a battery.

It features a very low dropout voltage of 100 mV, when the output current is less than 100 mA. In addition, the dropout region begins at input voltages of 3.3 V (extended operating range). This makes the TLF80511 suitable to supply automotive systems.

In addition, the TLF80511's new fast regulation concept requires only a single, 1 μF output capacitor to maintain stable regulation.

The device is designed for the harsh environment of automotive applications. Therefore standard features like output current limitation and overtemperature shutdown are implemented and protect the device against failures like output short circuit to GND, over-current and over-temperatures. The TLF80511 can be also used in all other applications requiring a stabilized 5 V supply voltage.

Type	Package	Marking
TLF80511TC	PG-TO263-3	TLF80511

2 Block Diagram

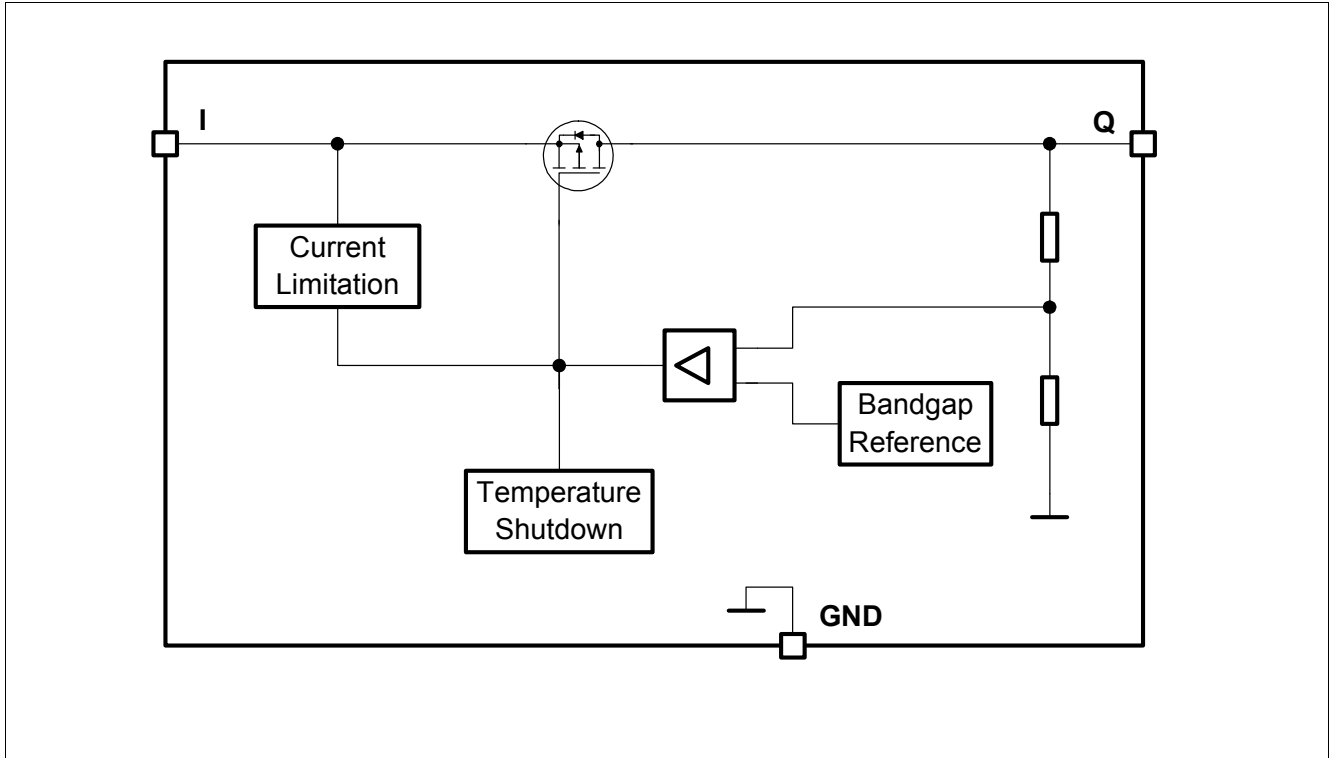

Figure 1 Block Diagram

3 Pin Configuration

3.1 Pin Assignment PG-TO263-3

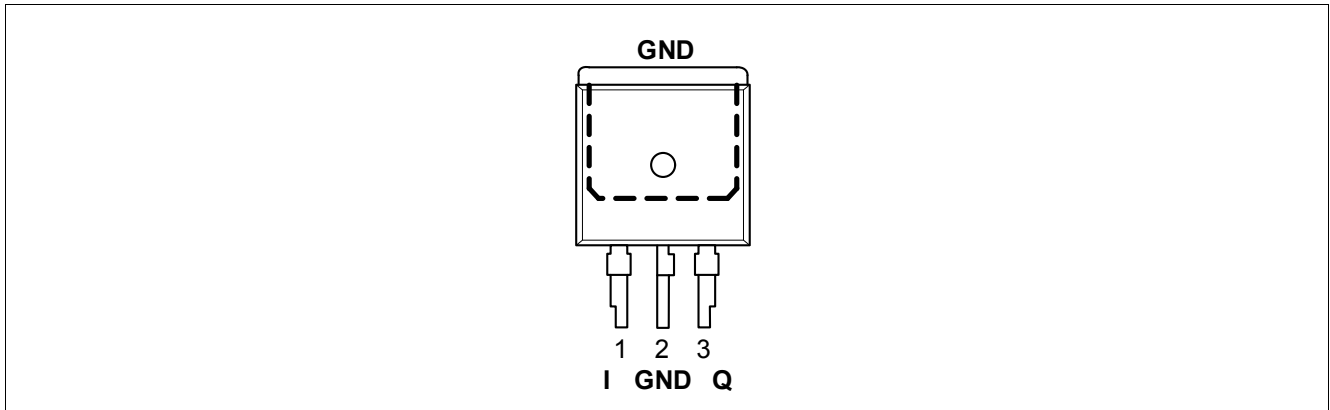

Figure 2 Pin Configuration

3.2 Pin Definitions and Functions PG-TO263-3

Pin	Symbol	Function
1	I	Input for compensating line influences, a capacitor to GND close to the IC terminals is recommended
2	GND	Ground
3	Q	Output block to GND with a capacitor close to the IC terminals, respecting the values given for its capacitance C_Q and ESR in the table “Functional Range” on Page 6
Tab	GND	Heat Slug connect to heatsink area; connect with GND on PCB

4 General Product Characteristics

4.1 Absolute Maximum Ratings

Absolute Maximum Ratings ¹⁾

-40 °C ≤ T_j ≤ 150 °C; all voltages with respect to ground, positive current flowing into pin (unless otherwise specified)

Pos.	Parameter	Symbol	Limit Values		Unit	Conditions
			Min.	Max.		
Input I						
4.1.1	Voltage	V_I	-0.3	45	V	–
Output Q						
4.1.2	Voltage	V_Q	-0.3	7	V	–
Temperature						
4.1.3	Junction Temperature	T_j	-40	150	°C	–
4.1.4	Storage Temperature	T_{stg}	-50	150	°C	–
ESD Absorption						
4.1.5	ESD Absorption	$V_{ESD,HBM}$	-4	4	kV	Human Body Model (HBM) ²⁾
4.1.6		$V_{ESD,CDM}$	-1.5	1.5	kV	Charge Device Model (CDM) ³⁾

1) Not subject to production test, specified by design.

2) ESD HBM Test according AEC-Q100-002 - JESD22-A114 (1.5kOhm, 100pF)

3) ESD CDM Test according ESDA STM5.3.1

Note: Stresses above the ones listed here may cause permanent damage to the device. Exposure to absolute maximum rating conditions for extended periods may affect device reliability.

Note: Integrated protection functions are designed to prevent IC destruction under fault conditions described in the data sheet. Fault conditions are considered as "outside" normal operating range. Protection functions are not designed for continuous repetitive operation.

4.2 Functional Range

Pos.	Parameter	Symbol	Limit Values		Unit	Conditions
			Min.	Max.		
4.2.1	Input Voltage Range for Normal Operation	V_I	$V_{Q,nom} + V_{dr}$	40	V	–
4.2.2	Extended Input Voltage Range	$V_{I,ext}$	3.3	40	V	– ¹⁾
4.2.3	Output Capacitor's Requirements for Stability	C_Q	1	–	μF	– ²⁾
		$ESR(C_Q)$	–	5	Ω	– ³⁾
4.2.4	Junction Temperature	T_j	-40	150	°C	–

1) Between min. value and $V_{Q,nom} + V_{dr}$: $V_Q = V_I - V_{dr}$. Below min. value: $V_Q = 0$ V

2) the minimum output capacitance requirement is applicable for a worst case capacitance tolerance of 30%

3) relevant ESR value at $f = 10$ kHz

Note: Within the functional range the IC operates as described in the circuit description. The electrical characteristics are specified within the conditions given in the related electrical characteristics table.

4.3 Thermal Resistance

Note: This thermal data was generated in accordance with JEDEC JESD51 standards. For more information, go to www.jedec.org.

Pos.	Parameter	Symbol	Limit Values			Unit	Conditions
			Min.	Typ.	Max.		
Package Versions PG-TO263-3							
4.3.1	Junction to Case ¹⁾	R_{thJC}	–	4	–	K/W	–
4.3.2	Junction to Ambient ¹⁾	R_{thJA}	–	22	–	K/W	²⁾
4.3.3			–	65	–	K/W	footprint only ³⁾
4.3.4			–	39	–	K/W	300 mm ² heatsink area on PCB ³⁾
4.3.5			–	33	–	K/W	600 mm ² heatsink area on PCB ³⁾

1) Not subject to production test, specified by design

2) Specified R_{thJA} value is according to Jedec JESD51-2,-5,-7 at natural convection on FR4 2s2p board; The Product (Chip+Package) was simulated on a 76.2 x 114.3 x 1.5 mm³ board with 2 inner copper layers (2 x 70μm Cu, 2 x 35μm Cu). Where applicable a thermal via array under the exposed pad contacted the first inner copper layer.

3) Specified R_{thJA} value is according to JEDEC JESD 51-3 at natural convection on FR4 1s0p board; The Product (Chip+Package) was simulated on a 76.2 x 114.3 x 1.5 mm³ board with 1 copper layer (1 x 70μm Cu).

5 Block Description and Electrical Characteristics

5.1 Voltage Regulation

The output voltage V_Q is divided by a resistor network. This fractional voltage is compared to an internal voltage reference and drives the pass transistor accordingly.

The control loop stability depends on the output capacitor C_Q , the load current, the chip temperature and the internal circuit design. To ensure stable operation, the output capacitor's capacitance and its equivalent series resistor ESR requirements given in [Table 4.2 "Functional Range" on Page 6](#) must be maintained. For details see the typical performance graph "[Stability Region: Equivalent Serial Resistor ESR versus Output Current IQ](#)" on [Page 12](#). Since the output capacitor is used to buffer load steps, it should be sized according to the application's needs.

An input capacitor C_I is not required for stability, but is recommended to compensate line fluctuations. An additional reverse polarity protection diode and a combination of several capacitors for filtering should be used. Connect the capacitors close to the regulator terminals.

Whenever the load current exceeds the specified limit, e.g. in case of a short circuit, the output current is limited and the output voltage decreases.

The overtemperature shutdown circuit prevents the IC from immediate destruction under fault conditions (e.g. output continuously short-circuited) by switching off the power stage. After the chip has cooled, the regulator restarts. This oscillatory thermal behaviour causes the junction temperature to exceed the 150° C maximum and significantly reducing the IC's life.

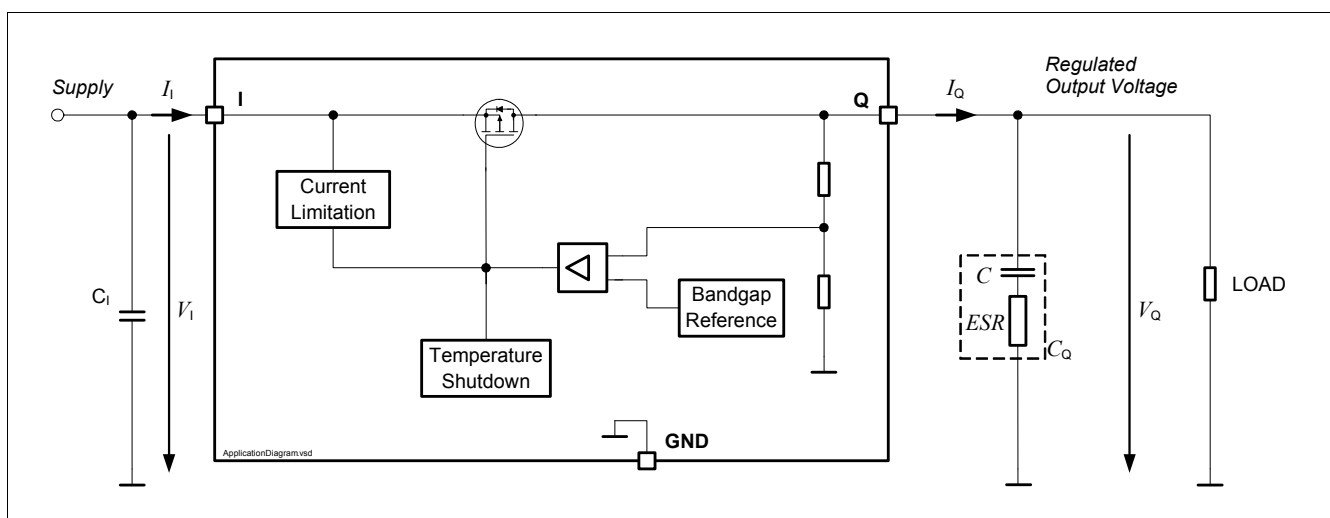

Figure 3 Block Diagram Voltage Regulation

Block Description and Electrical Characteristics

Electrical Characteristics Voltage Regulator 5 V version

$V_I = 13.5 \text{ V}$, $-40 \text{ }^\circ\text{C} \leq T_j \leq 150 \text{ }^\circ\text{C}$, all voltages with respect to ground, positive current flowing into pin (unless otherwise specified)

Pos.	Parameter	Symbol	Limit Values			Unit	Conditions
			Min.	Typ.	Max.		
5.1.1	Output Voltage Precision	V_Q	4.9	5.0	5.1	V	$0.05 \text{ mA} < I_Q < 400 \text{ mA}$ $6 \text{ V} < V_I < 28 \text{ V}$
5.1.2	Output Voltage Precision	V_Q	4.9	5.0	5.1	V	$0.05 \text{ mA} < I_Q < 200 \text{ mA}$ $5.5 \text{ V} < V_I < 40 \text{ V}$
5.1.3	Output Current Limitation	$I_{Q,max}$	401	600	900	mA	$0 \text{ V} < V_Q < 4.8 \text{ V}$
5.1.4	Load Regulation steady-state	$ \Delta V_{Q,load} $	–	20	50	mV	$I_Q = 0.05 \text{ mA}$ to 400 mA $V_I = 6 \text{ V}$
5.1.5	Line Regulation steady-state	$ \Delta V_{Q,line} $	–	10	30	mV	$V_I = 8 \text{ V}$ to 32 V $I_Q = 5 \text{ mA}$
5.1.6	Dropout Voltage ¹⁾ $V_{dr} = V_I - V_Q$	V_{dr}	–	250	500	mV	$I_Q = 250 \text{ mA}$
			–	100	200	mV	$I_Q = 100 \text{ mA}$
5.1.7	Power Supply Ripple Rejection ²⁾	$PSRR$	–	55	–	dB	$f_{ripple} = 100 \text{ Hz}$ $V_{ripple} = 0.5 \text{ Vpp}$
5.1.8	Overtemperature Shutdown Threshold	$T_{j,sd}$	151	175	200	$^\circ\text{C}$	T_j increasing ²⁾
5.1.9	Overtemperature Shutdown Threshold Hysteresis	$T_{j,sdh}$	–	15	–	K	T_j decreasing ²⁾

1) Measured when the output voltage V_Q has dropped 100 mV from the nominal value obtained at $V_I = 13.5 \text{ V}$

2) Not subject to production test, specified by design

5.2 Current Consumption

Electrical Characteristics Current Consumption

$V_I = 13.5 \text{ V}$, $-40 \text{ °C} \leq T_j \leq 150 \text{ °C}$, positive current flowing into pin
(unless otherwise specified)

Pos.	Parameter	Symbol	Limit Values			Unit	Conditions
			Min.	Typ.	Max.		
5.2.1	Current Consumption $I_q = I_I - I_Q$	I_q	–	38	46	μA	$I_Q = 0.05 \text{ mA}$ $T_j < 25 \text{ °C}$
5.2.2			–	–	75	μA	$I_Q = 0.05 \text{ mA}$ $T_j < 125 \text{ °C}$
5.2.3			–	67	80	μA	$I_Q = 400 \text{ mA}$ $T_j < 125 \text{ °C}^{1)}$

1) Not subject to production test, specified by design.

5.3 Typical Performance Characteristics Voltage Regulator

Current Consumption I_q versus Output Current I_Q

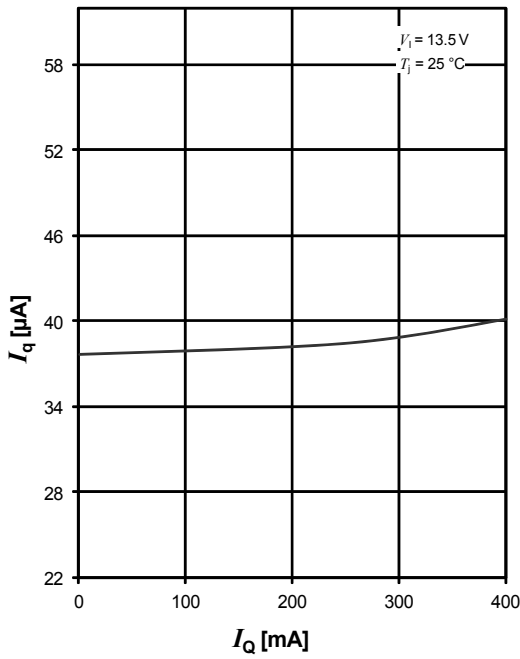

Dropout Voltage V_{dr} versus Junction Temperature T_j

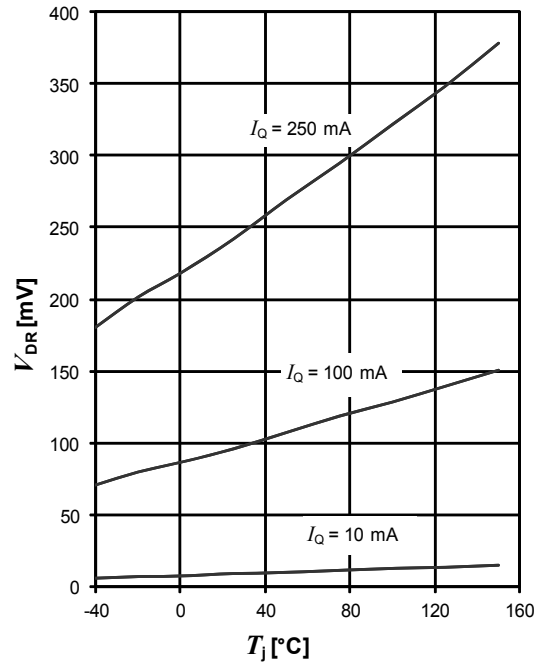

Dropout Voltage V_{dr} versus Output Current I_Q

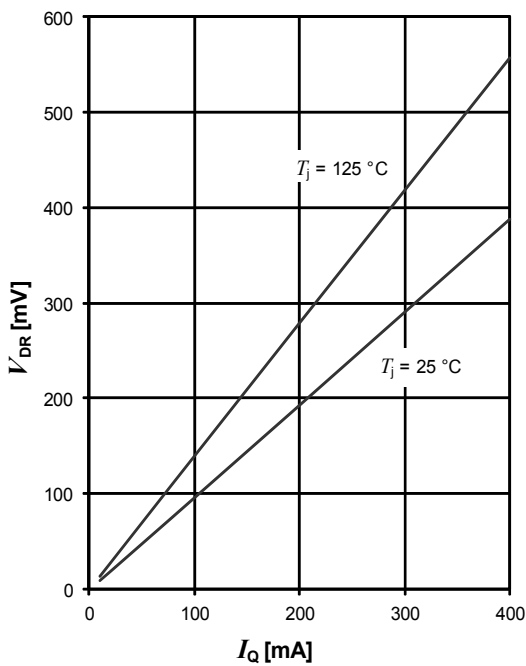

Output Voltage V_Q versus Junction Temperature T_j

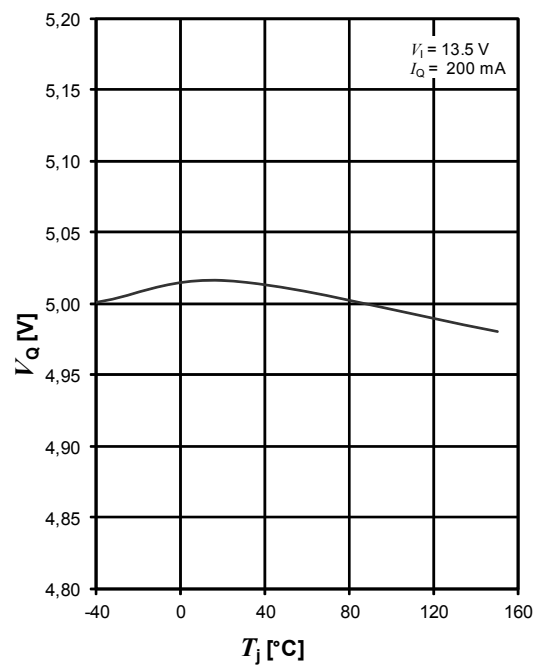

Output Voltage ΔV_Q versus Output Current ΔI_Q

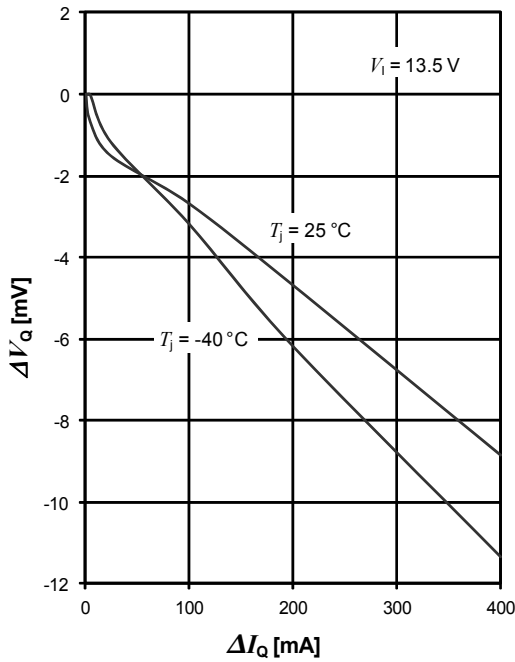

Output Voltage ΔV_Q versus Input Voltage ΔV_I

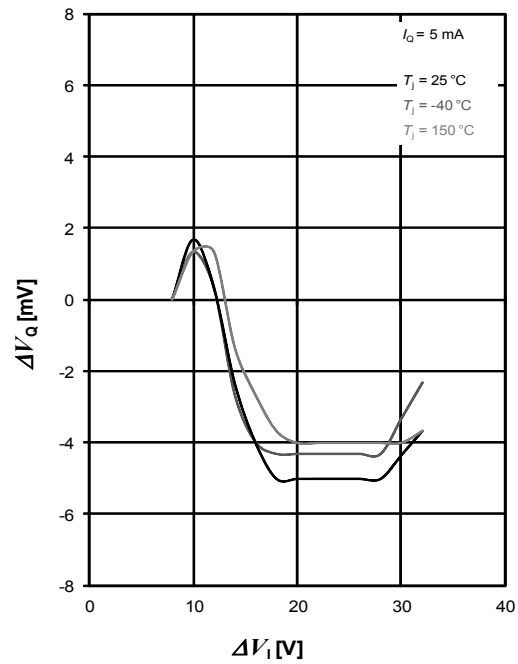

Maximum Output Current $I_{Q,max}$ versus Input Voltage V_I

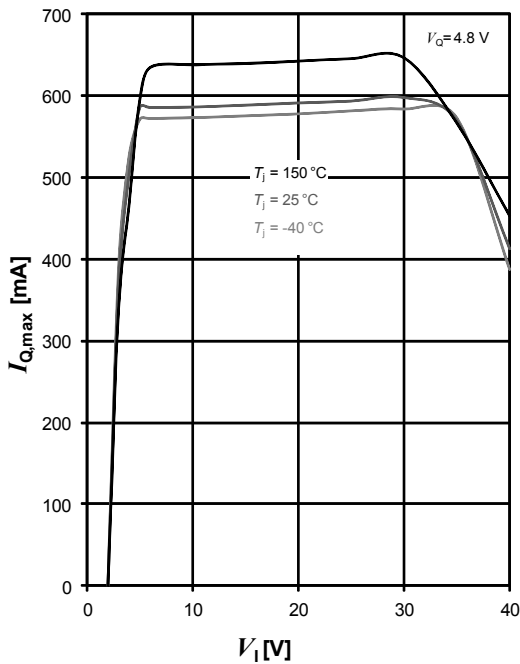

Current Consumption I_Q versus Input Voltage V_I

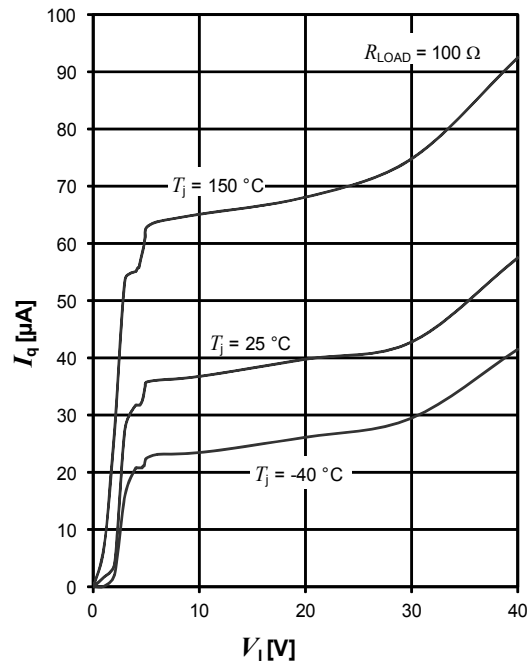

Power Supply Ripple Rejection versus Frequency

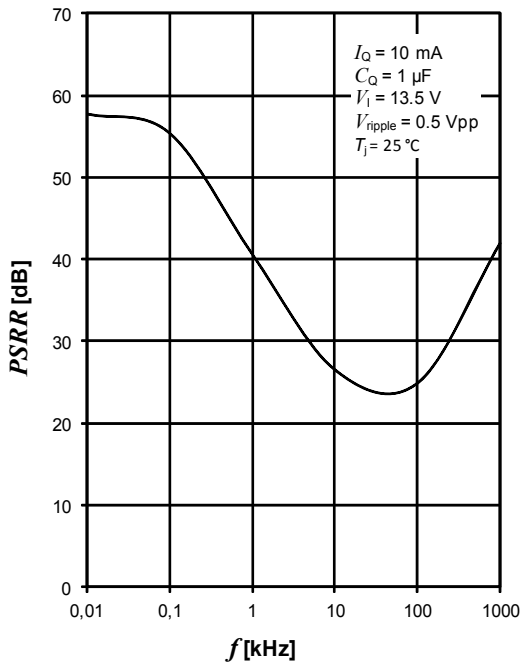

Stability Region: Equivalent Serial Resistor ESR versus Output Current I_Q

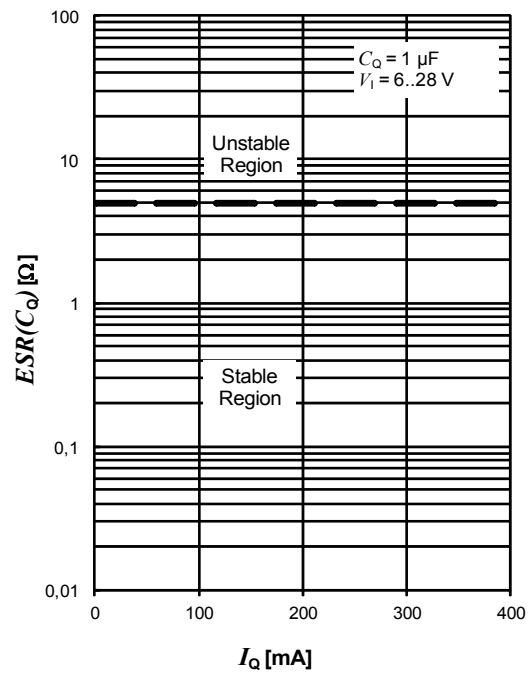

Output Voltage V_Q versus Input Voltage V_I

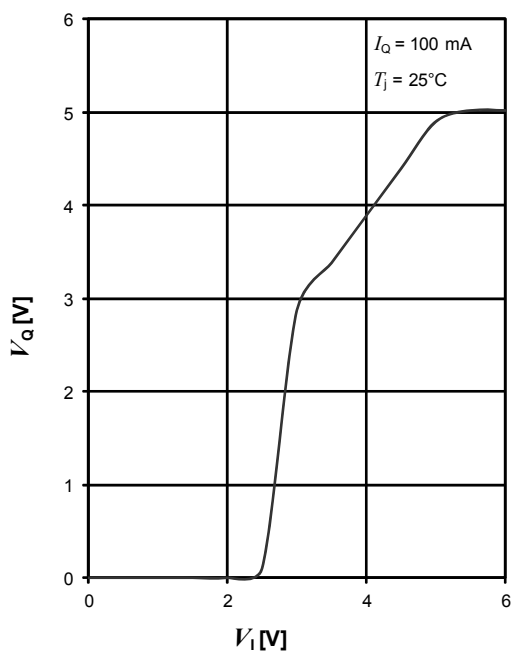

6 Package Outlines

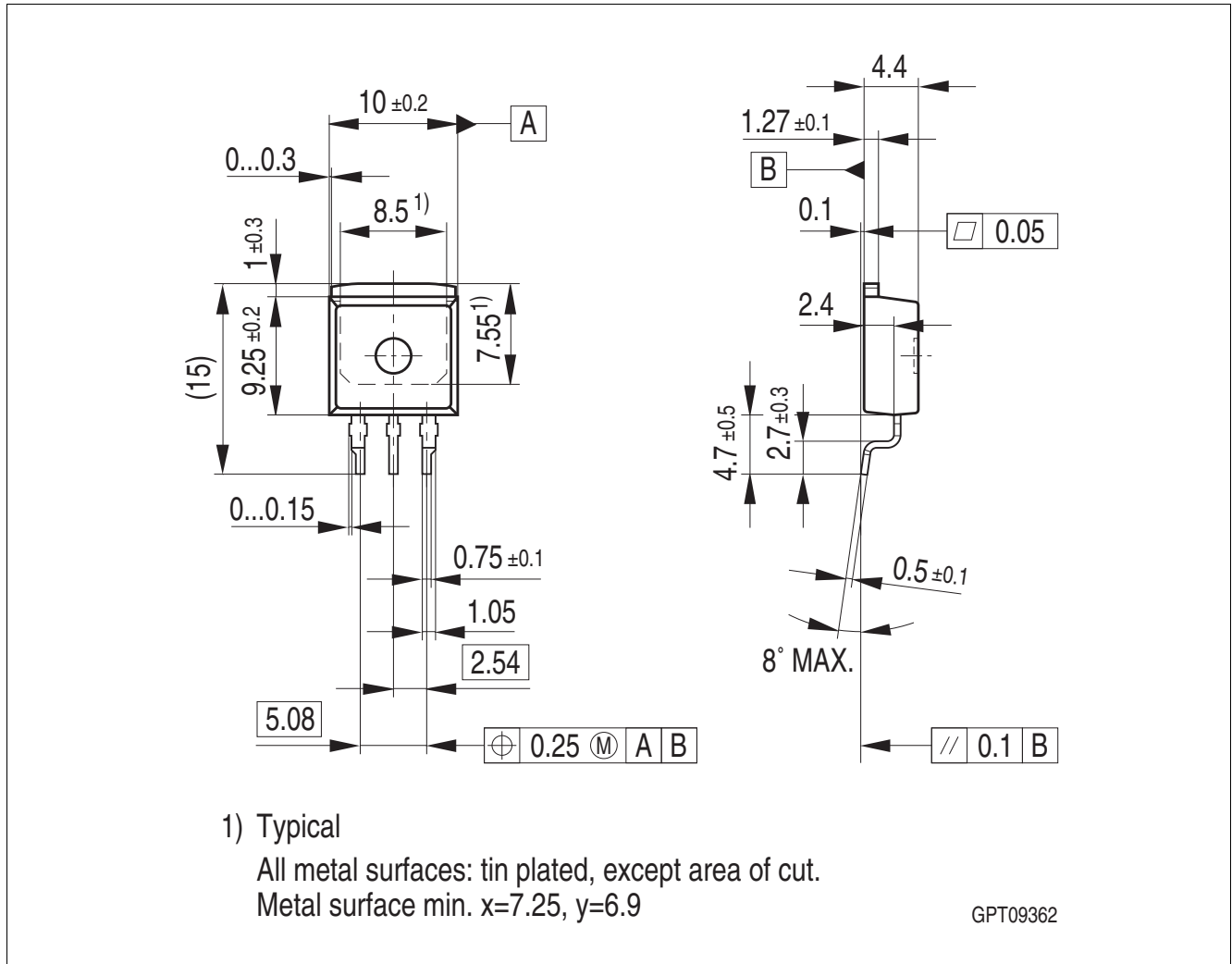

Figure 4 PG-TO263-3

7 Revision History

Revision	Date	Changes
1.01	2016-06-21	Editorial change: corrected page number Updated disclaimer
1.0	2012-06-15	Data Sheet - Initial Version

Trademarks of Infineon Technologies AG

μ HVIC™, μ IPM™, μ PFC™, AU-ConvertIR™, AURIX™, C166™, CanPAK™, CIPOS™, CIPURSE™, CoolDP™, CoolGaN™, COOLiR™, CoolMOS™, CoolSET™, CoolSiC™, DAVE™, DI-POL™, DirectFET™, DrBlade™, EasyPIM™, EconoBRIDGE™, EconoDUAL™, EconoPACK™, EconoPIM™, EiceDRIVER™, eupec™, FCOS™, GaNpowIR™, HEXFET™, HITFET™, HybridPACK™, iMOTION™, IRAM™, ISOFACE™, IsoPACK™, LEDriviR™, LITIX™, MIPAQ™, ModSTACK™, my-d™, NovalithIC™, OPTIGA™, OptiMOS™, ORIGA™, PowIRaudio™, PowIRstage™, PrimePACK™, PrimeSTACK™, PROFET™, PRO-SIL™, RASIC™, REAL3™, SmartLEWIS™, SOLID FLASH™, SPOC™, StrongIRFET™, SupIRBuck™, TEMPFET™, TRENCHSTOP™, TriCore™, UHVIC™, XHP™, XMC™.

Trademarks updated November 2015

Other Trademarks

All referenced product or service names and trademarks are the property of their respective owners.

Edition 2016-06-21

Published by

Infineon Technologies AG

81726 Munich, Germany

© 2016 Infineon Technologies AG.

All Rights Reserved.

Do you have a question about any aspect of this document?

Email: erratum@infineon.com

IMPORTANT NOTICE

The information given in this document shall in no event be regarded as a guarantee of conditions or characteristics ("Beschaffheitsgarantie").

With respect to any examples, hints or any typical values stated herein and/or any information regarding the application of the product, Infineon Technologies hereby disclaims any and all warranties and liabilities of any kind, including without limitation warranties of non-infringement of intellectual property rights of any third party.

In addition, any information given in this document is subject to customer's compliance with its obligations stated in this document and any applicable legal requirements, norms and standards concerning customer's products and any use of the product of Infineon Technologies in customer's applications.

The data contained in this document is exclusively intended for technically trained staff. It is the responsibility of customer's technical departments to evaluate the suitability of the product for the intended application and the completeness of the product information given in this document with respect to such application.

For further information on technology, delivery terms and conditions and prices, please contact the nearest Infineon Technologies Office (www.infineon.com).

WARNINGS

Due to technical requirements products may contain dangerous substances. For information on the types in question please contact your nearest Infineon Technologies office.

Except as otherwise explicitly approved by Infineon Technologies in a written document signed by authorized representatives of Infineon Technologies, Infineon Technologies' products may not be used in any applications where a failure of the product or any consequences of the use thereof can reasonably be expected to result in personal injury.

Looking for pricing, stock, or lifecycle information?

Click below to explore more details on WIN SOURCE:

-  [View TLF80511TC on WIN SOURCE](#)
-  [Infineon Technologies Information](#)

Optimize Your Supply Chain with WIN SOURCE Solutions

-  Global Sourcing Solution
-  Obsolete Management
-  Cost Control Management
-  Shortage Management
-  Alternative Solution
-  Excess Inventory Management