



THE DATASHEET OF TLV431BFTA



Description

The TLV431 is a three-terminal, adjustable shunt regulator offering excellent temperature stability and output current handling capability up to 20mA. The output voltage may be set to any chosen voltage between 1.24V and 18V by selection of two external divider resistors.

The TLV431 can be used as a replacement for zener diodes in many applications requiring an improvement in zener performance.

The TLV431 is available in three grades with initial tolerances of 1%, 0.5%, and 0.2% for the A, B, and T grades respectively.

Features

- Low-Voltage Operation $V_{REF} = 1.24V$
- Temperature Range $-40^{\circ}C$ to $+125^{\circ}C$
- Reference Voltage Tolerance at $+25^{\circ}C$
 - 0.2% TLV431T
 - 0.5% TLV431B
 - 1% TLV431A
- Typical Temperature Drift
 - 4mV (0 to $+70^{\circ}C$)
 - 6mV ($-40^{\circ}C$ to $+85^{\circ}C$)
 - 11mV ($-40^{\circ}C$ to $+125^{\circ}C$)
- 80 μ A Minimum Cathode Current
- 0.25 Ω Typical Output Impedance
- Adjustable Output Voltage V_{REF} to 18V
- **Totally Lead-Free & Fully RoHS Compliant (Notes 1 & 2)**
- **Halogen and Antimony Free. "Green" Device (Note 3)**
- **An automotive-compliant part is available under separate datasheet ([TLV431Q](#))**

Pin Assignments

TLV431_H6 (SC70-6 [SOT363])

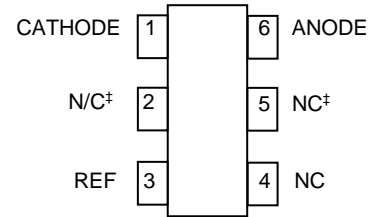

(Top View)

TLV431_F (SOT23)

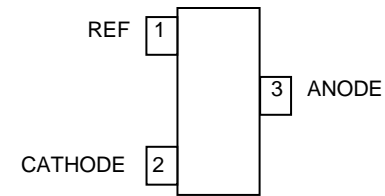

(Top View)

TLV431_E5 (SOT25)

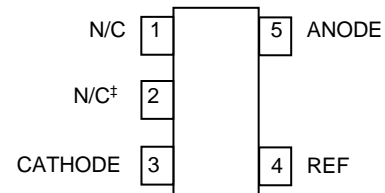

(Top View)

‡ Pin should be left floating or connect to anode

Notes: 1. No purposely added lead. Fully EU Directive 2002/95/EC (RoHS), 2011/65/EU (RoHS 2) & 2015/863/EU (RoHS 3) compliant.
 2. See <https://www.diodes.com/quality/lead-free/> for more information about Diodes Incorporated's definitions of Halogen- and Antimony-free, "Green" and Lead-free.
 3. Halogen- and Antimony-free "Green" products are defined as those which contain <900ppm bromine, <900ppm chlorine (<1500ppm total Br + Cl) and <1000ppm antimony compounds.

Typical Application Circuit

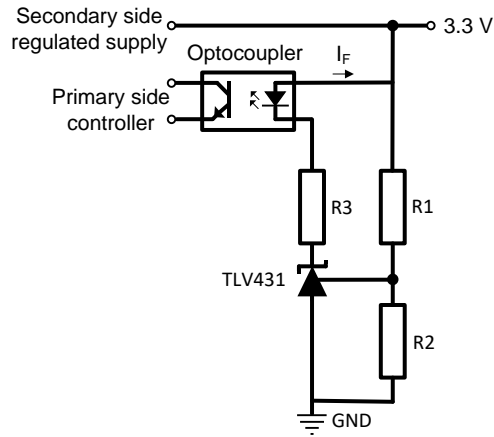

Absolute Maximum Ratings (@T_A = +25°C, unless otherwise specified.)

Symbol	Parameter	Rating	Unit
V _{KA}	Cathode Voltage	20	V
I _{KA}	Continuous Cathode Current	-20 to +20	mA
I _{REF}	Reference Input Current Range	-0.05 to +3	mA
ESD Susceptibility (Note 4)			
HBM	Human Body Model	4	kV
MM	Machine Model	400	V
CDM	Charged Device Model	1	kV

Note: 4. Semiconductor devices are ESD sensitive and can be damaged by exposure to ESD events. Suitable ESD precautions should be taken when handling and transporting these devices.

Parameter	Rating	Unit
Operating Junction Temperature (Note 5)	-40 to +150	°C
Storage Temperature (Note 5)	-65 to +150	°C

Note: 5. Operation above the absolute maximum rating can cause device failure. Operation at the absolute maximum ratings, for extended periods, can reduce device reliability. Unless otherwise stated voltages specified are relative to the ANODE pin. These are stress ratings only. Operation outside the absolute maximum ratings can cause device failure.

Recommended Operating Conditions (@T_A = +25°C, unless otherwise specified.)

Symbol	Parameter	Min	Max	Units
V _{KA}	Cathode Voltage	V _{REF}	18	V
I _{KA}	Cathode Current	0.1	15	mA
T _A	Operating Ambient Temperature Range	-40	+125	°C

Package Thermal Data

Package	θ _{JA}	P _{DIS} T _A = +25°C, T _J = +150°C
SOT23	380°C/W	330mW
SOT25	250°C/W	500mW
SC70-6 (SOT363)	380°C/W	330mW

Electrical Characteristics ($I_{KA} = 10\text{mA}$, $T_A = +25^\circ\text{C}$, unless otherwise specified.)

Symbol	Parameter	Conditions	Min	Typ	Max	Units	
V_{REF}	Reference Voltage	$V_{KA} = V_{REF}$, $T_A = +25^\circ\text{C}$	TLV431A	1.228	1.24	1.252	V
			TLV431B	1.234	1.24	1.246	
			TLV431T	1.2375	1.24	1.2425	
		$V_{KA} = V_{REF}$, $T_A = 0 \text{ to } +70^\circ\text{C}$	TLV431A	1.221	—	1.259	
			TLV431B	1.227	—	1.253	
			TLV431T	1.230	—	1.250	
		$V_{KA} = V_{REF}$, $T_A = -40^\circ\text{C to } +85^\circ\text{C}$	TLV431A	1.215	—	1.265	
			TLV431B	1.224	—	1.259	
			TLV431T	1.228	—	1.252	
		$V_{KA} = V_{REF}$, $T_A = -40^\circ\text{C to } +125^\circ\text{C}$	TLV431A	1.209	—	1.271	
			TLV431B	1.221	—	1.265	
			TLV431T	1.224	—	1.255	
$V_{REF(dev)}$	Deviation of Reference Voltage Over Full Temperature Range	$V_{KA} = V_{REF}$	$T_A = 0 \text{ to } +70^\circ\text{C}$	—	4	12	mV
			$T_A = -40^\circ\text{C to } +85^\circ\text{C}$	—	6	20	
			$T_A = -40^\circ\text{C to } +125^\circ\text{C}$	—	11	31	
$\frac{\Delta V_{REF}}{\Delta V_{KA}}$	Ratio of Change in Reference Voltage to Change in Cathode Voltage	V_{KA} for V_{REF} to	6V	—	-1.5	-2.7	mV/V
			18V	—	-1.5	-2.7	
I_{REF}	Reference Input Current	$R_1 = 10\text{k}\Omega$, $R_2 = \text{OC}$	—	0.15	0.5	μA	
$I_{REF(dev)}$	I_{REF} Deviation Over Full Temperature Range	$R_1 = 10\text{k}\Omega$, $R_2 = \text{OC}$	$T_A = 0 \text{ to } +70^\circ\text{C}$	—	0.05	0.3	μA
			$T_A = -40^\circ\text{C to } +85^\circ\text{C}$	—	0.1	0.4	
			$T_A = -40^\circ\text{C to } +125^\circ\text{C}$	—	0.15	0.5	
I_{KMIN}	Minimum Cathode Current for Regulation	$V_{KA} = V_{REF}$	$T_A = 0 \text{ to } +70^\circ\text{C}$	—	55	80	μA
			$T_A = -40^\circ\text{C to } +85^\circ\text{C}$	—	55	80	
			$T_A = -40^\circ\text{C to } +125^\circ\text{C}$	—	55	100	
$I_{K(OFF)}$	Off-State Current	$V_{KA} = 18\text{V}$, $V_{REF} = 0$	—	0.001	0.1	μA	
Z_{KA}	Dynamic Output Impedance	$V_{KA} = V_{REF}$, $f = <1\text{kHz}$ $I_K = 0.1\text{mA to } 15\text{mA}$	—	0.25	0.4	Ω	

Typical Characteristics

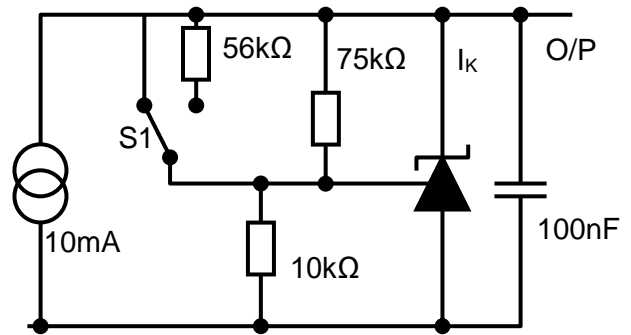
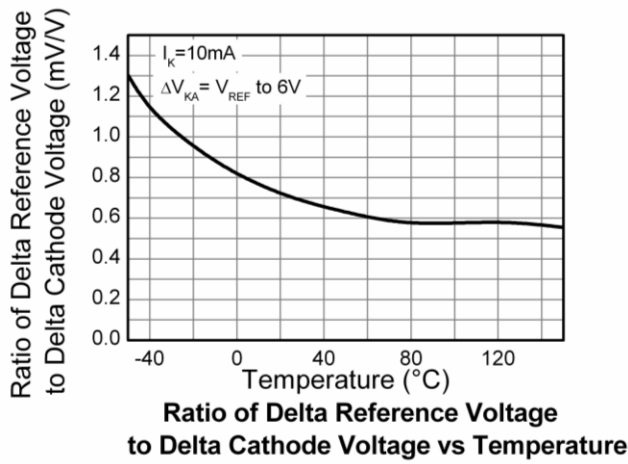
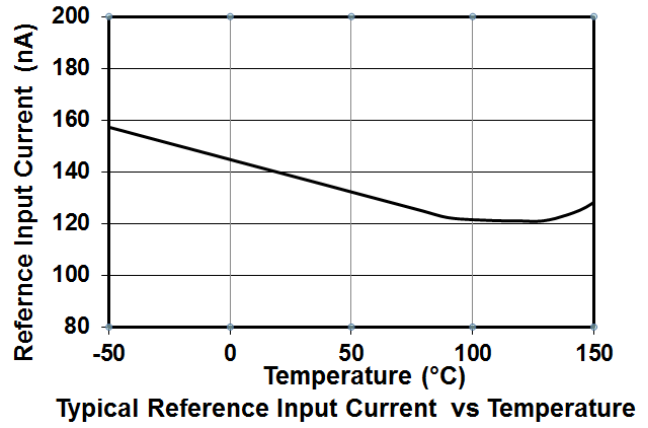
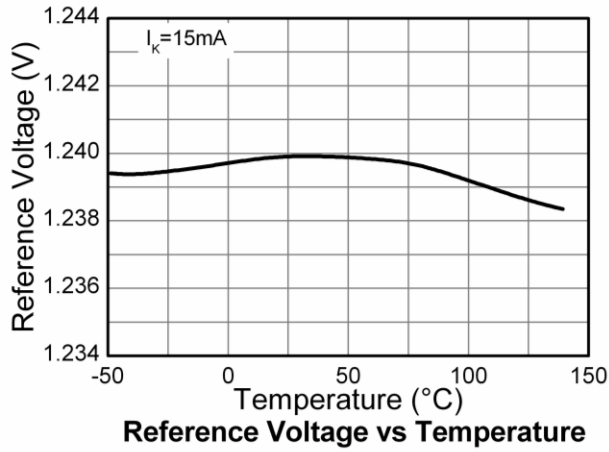

Test Circuit for V_{REF} Measurement

Typical Characteristics (continued)

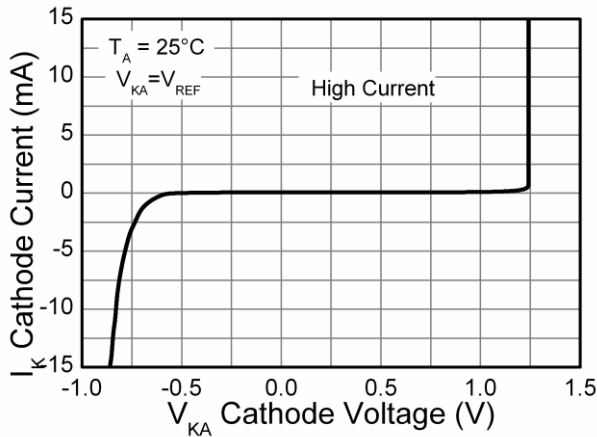

Cathode Current vs Voltage

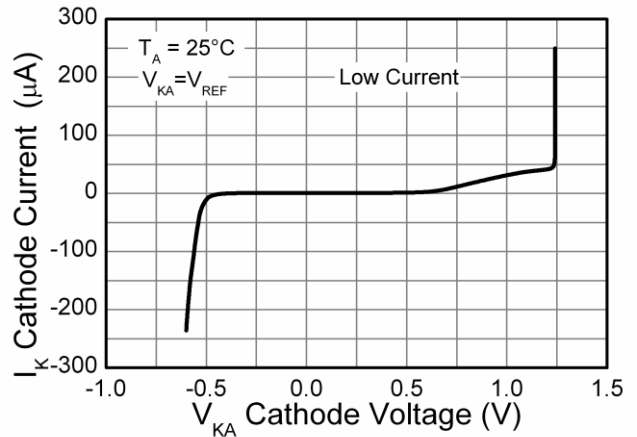

Cathode Current vs Voltage

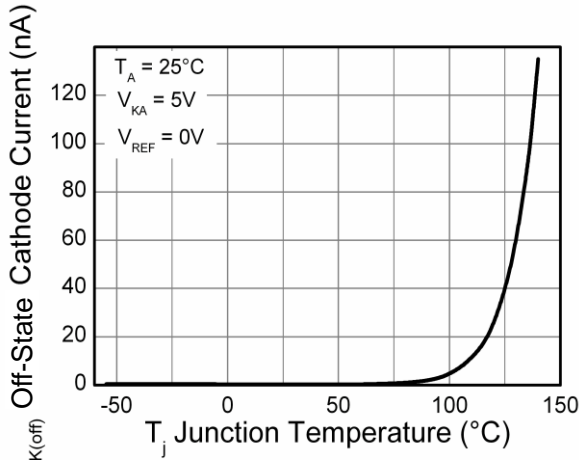

Off-State Current vs Junction Temperature

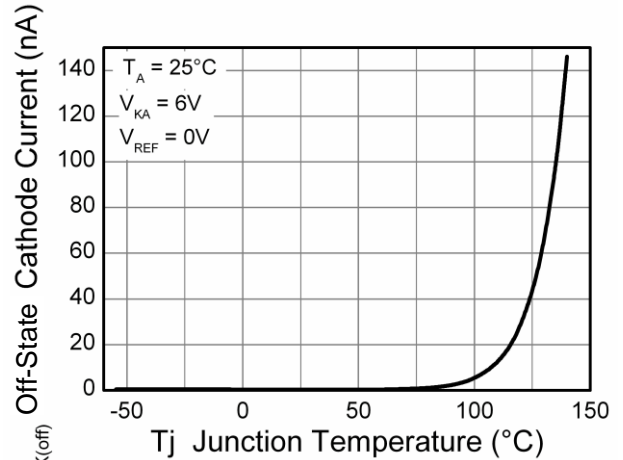

Off-State Current vs Junction Temperature

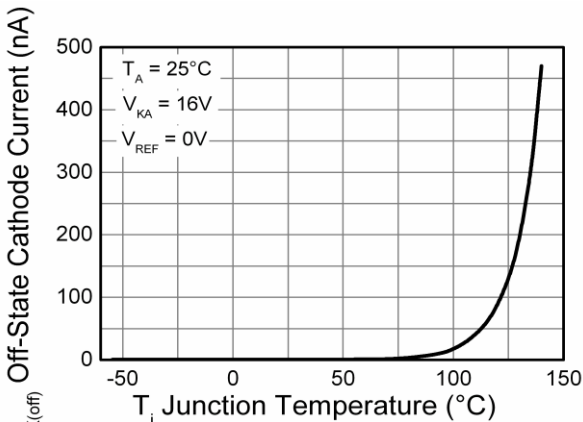

Off-State Current vs Junction Temperature

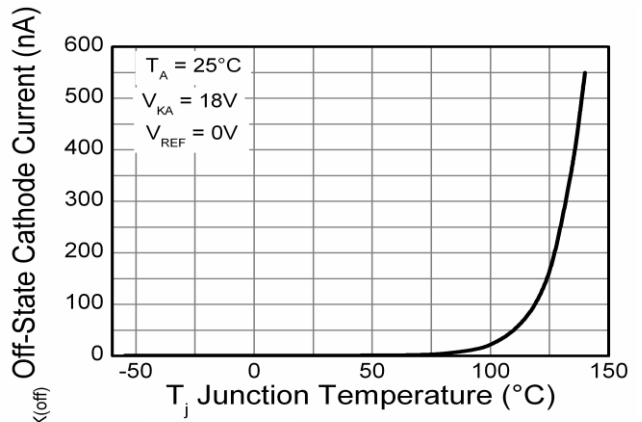

Off-State Current vs Junction Temperature

Typical Characteristics (continued)

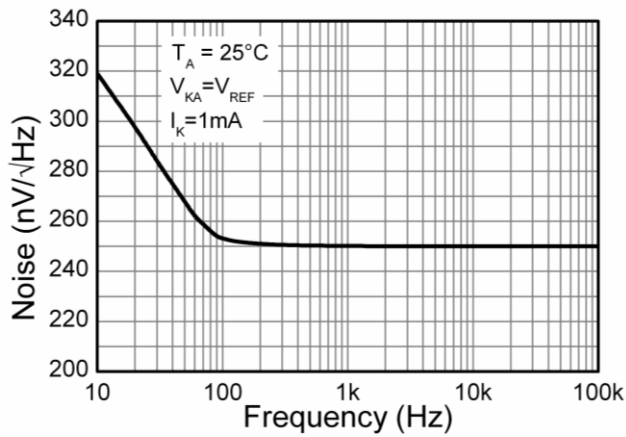

Equivalent Input Noise Voltage vs Frequency

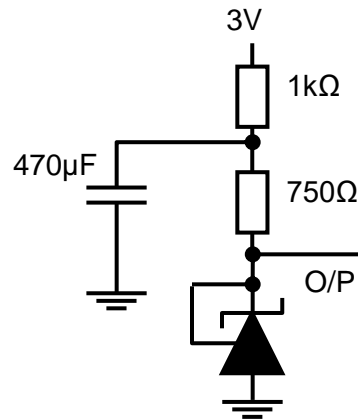

Test Circuit for Input Noise Voltage

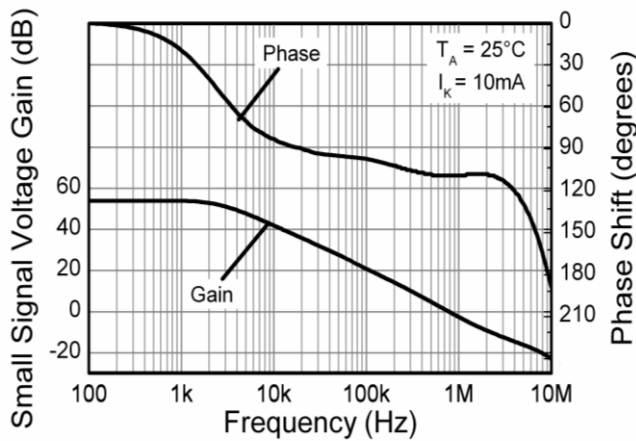

Phase Shift and Gain vs Frequency

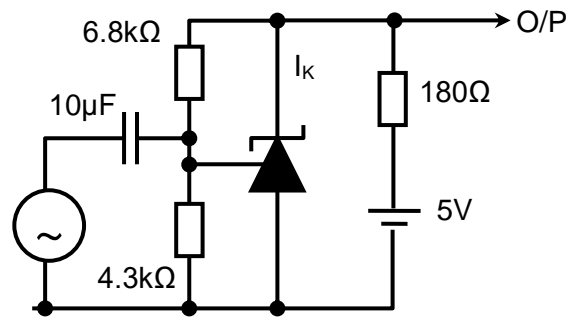

Test Circuit for Phase Shift and Gain

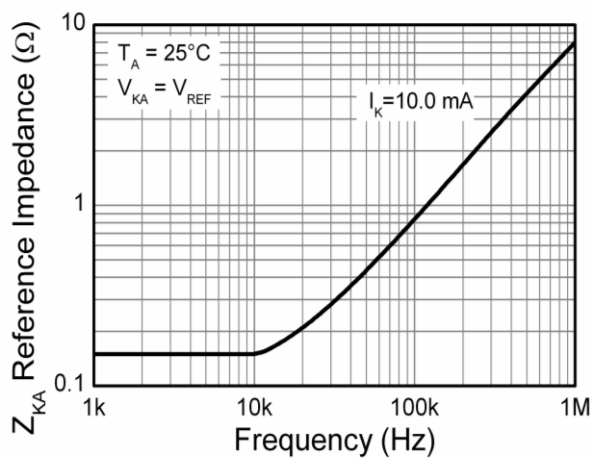

Reference Impedance vs Frequency

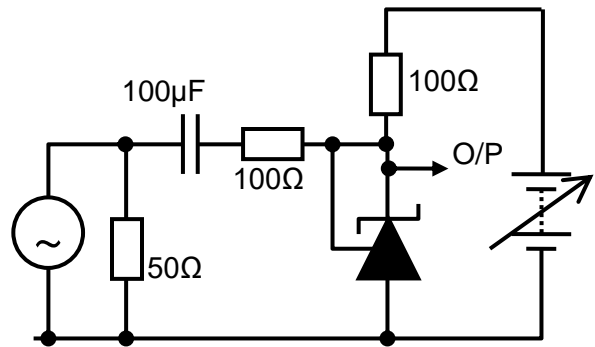

Test Circuit for Reference Impedance

Typical Characteristics (continued)

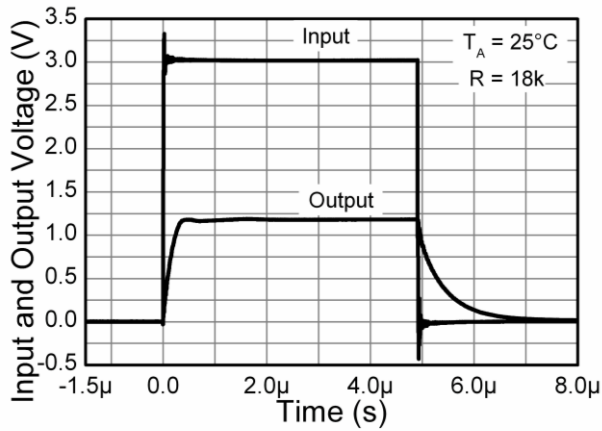

Pulse Response

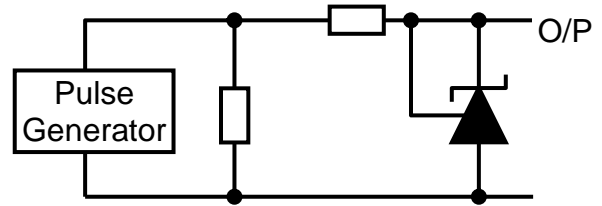

Test Circuit for Pulse Response

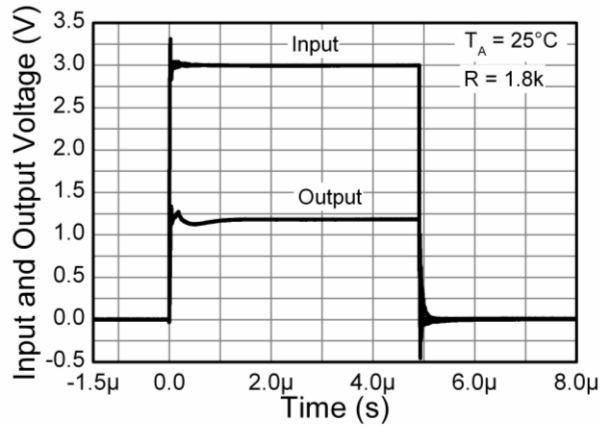

Pulse Response

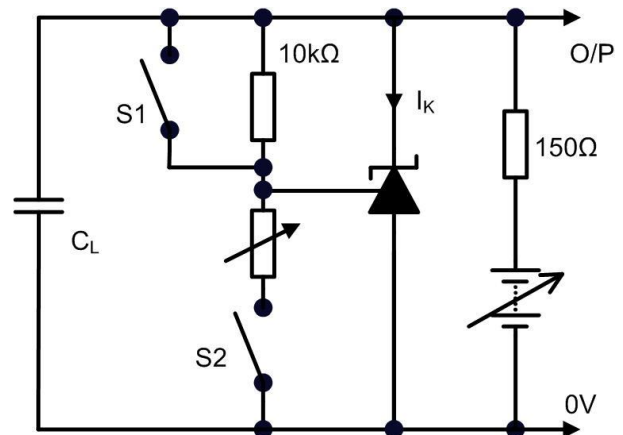
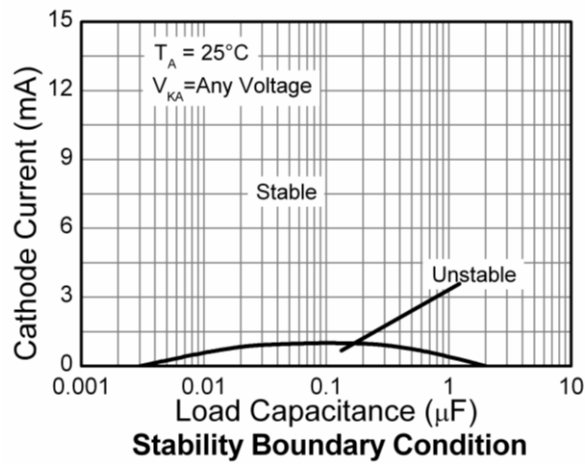

Application Notes

In a conventional shunt regulator application (Figure 1), an external series resistor (R_3) is connected between the supply voltage, V_{IN} , and the TLV431.

R_3 determines the current that flows through the load (I_L) and the TLV431 (I_K). The TLV431 adjusts how much current it sinks or “shunts” to maintain a voltage equal to V_{REF} across its feedback pin. Because load current and supply voltage may vary, R_3 should be small enough to supply at least the minimum acceptable I_{KMIN} to the TLV431, even when the supply voltage is at its minimum and the load current is at its maximum value. When the supply voltage is at its maximum and I_L is at its minimum, R_3 should be large enough so that the current flowing through the TLV431 is less than 15mA.

R_3 is determined by the supply voltage, (V_{IN}), the load and operating current, (I_L and I_K), and the TLV431’s reverse breakdown voltage, V_{KA} .

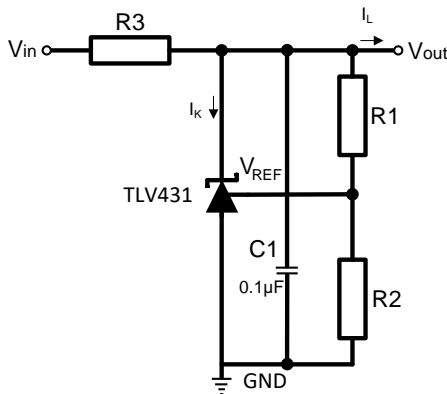

Figure 1

$$R_3 = \frac{V_{IN} - V_{KA}}{I_L + I_K}$$

where

$$V_{KA} = V_{REF} \times \left(1 + \frac{R_1}{R_2} \right)$$

and $V_{KA} = V_{OUT}$

The values of R_1 and R_2 should be large enough so that the current flowing through them is much smaller than the current through R_3 , yet not too large that the voltage drop across them causes I_{REF} to affect the reference accuracy.

The most frequent application of the TLV431 is in isolated, low-output voltage power supplies where the regulated output is galvanically isolated from the controller. As shown in Figure 2, the TLV431 drives current, I_F , through the optocoupler’s LED, which in turn drives the isolated transistor that is connected to the controller on the primary side of the power supply.

This completes the feedback path through the isolation barrier and ensures that a stable isolated supply is maintained.

Assuming a forward drop of 1.4V across the optocoupler diode allows output voltages as low as 2.7V to be regulated.

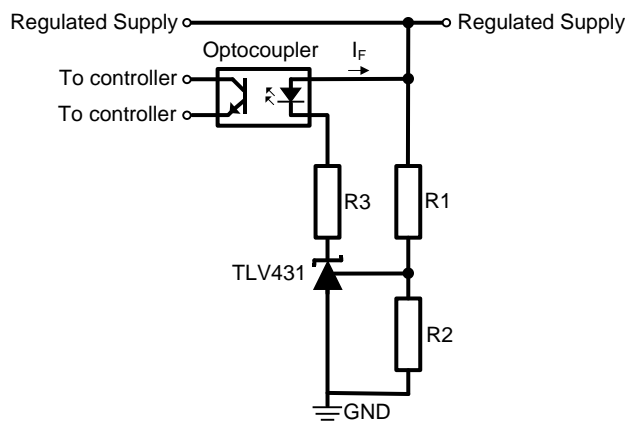

Figure 2. Using the TLV431 as the Regulating Element in an Isolated PSU

$$V_{OUT} = V_{REF} \left(1 + \frac{R_1}{R_2} \right)$$

$$\frac{V_{OUT} - 2.7}{I_{F(min)}} > R_3 \geq \frac{V_{OUT(max)} - 2.7}{15mA}$$

Application Notes (continued)

Printed Circuit Board Layout Considerations

The TLV431 in the SOT25 package has the die attached to pin 2, which results in an electrical contact between pin 2 and pin 5. Therefore, pin 2 of the SOT25 package must be left floating or connected to pin 5.

The TLV431 in the SC70-6 (SOT363) package has the die attached to pin 2 and 5, which results in an electrical contact between pins 2, 5, and pin 6. Therefore, pins 2 and 5 must be left floating or connected to pin 6.

Other Applications of the TLV431

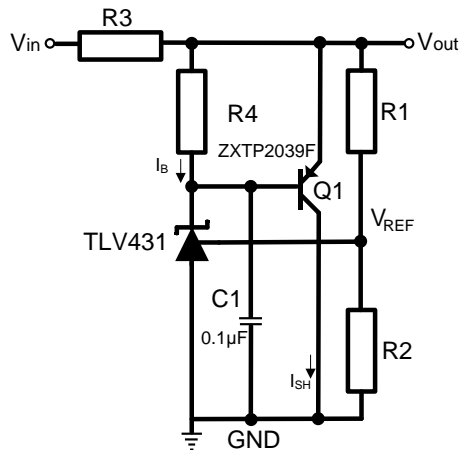

$$V_{OUT} = V_{REF} \left(1 + \frac{R1}{R2} \right)$$

$$R3 = \frac{V_{IN} - V_{OUT}}{I_{SH} + I_B}$$

$$R4 = \frac{V_{BE}}{I_B}$$

$$\left(\frac{I_{SH}}{h_{FE(min)}} \right) < I_B \leq 15mA$$

Figure 3. High-Current Shunt Regulator

It may at times be required to shunt-regulate more current than the 15mA that which the TLV431 is capable.

Figure 3 shows how this can be done using transistor Q1 to amplify the TLV431's current. Care must be taken so the power dissipation and/or SOA requirements of the transistor is not exceeded.

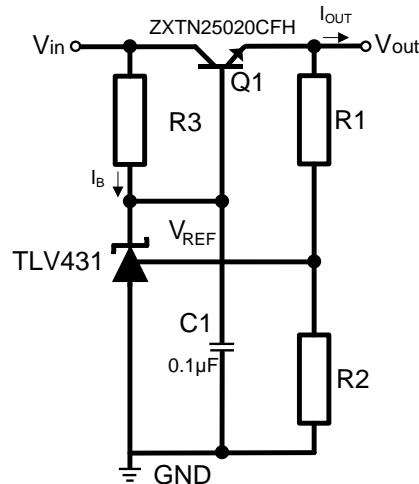

$$V_{OUT} = V_{REF} \left(1 + \frac{R1}{R2} \right)$$

$$R3 = \frac{V_{IN} - (V_{OUT} + V_{BE})}{I_B}$$

$$\left(\frac{I_{OUT(max)}}{h_{FE(min)}} \right) < I_B \leq 15mA$$

Figure 4. Basic Series Regulator

A very effective and simple series regulator can be implemented as shown in Figure 4. This may be preferable if the load requires more current than can be provided by the TLV431 alone, and conserving power when the load is not being powered is required. This circuit also uses one component less than the shunt circuit shown in Figure 3.

Application Notes (continued)

Printed Circuit Board Layout Considerations (continued)

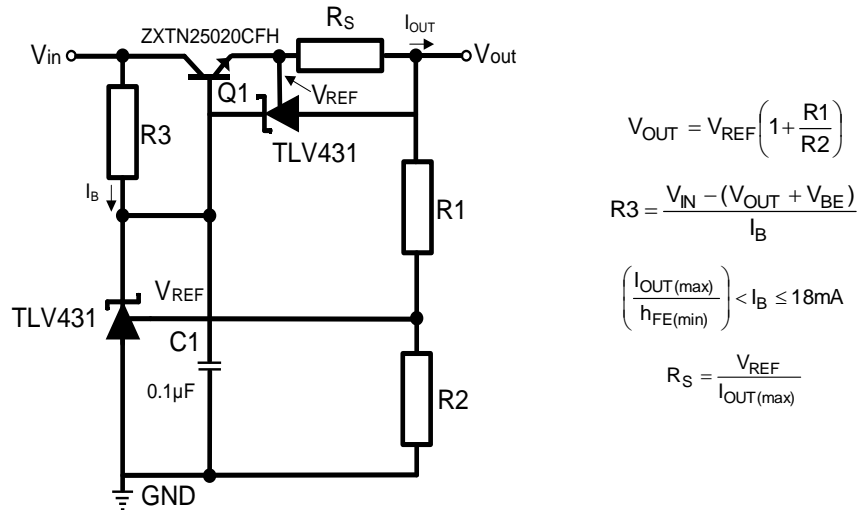

$$V_{OUT} = V_{REF} \left(1 + \frac{R1}{R2} \right)$$

$$R3 = \frac{V_{IN} - (V_{OUT} + V_{BE})}{I_B}$$

$$\left(\frac{I_{OUT(max)}}{h_{FE(min)}} \right) < I_B \leq 18mA$$

$$R_S = \frac{V_{REF}}{I_{OUT(max)}}$$

Figure 5. Series Regulator with Current Limit

Figure 5 adds current limit to the series regulator in Figure 4 by using a second TLV431. For currents below the limit, the circuit works normally supplying the required load current at the design voltage. However, should attempts be made to exceed the design current set by the second TLV431, the device begins to shunt current away from the base of Q1. This begins to reduce the output voltage and thus ensuring that the output current is clamped at the design value. Subject only to Q1's ability to withstand the resulting power dissipation, the circuit can withstand either a brief or indefinite short circuit.

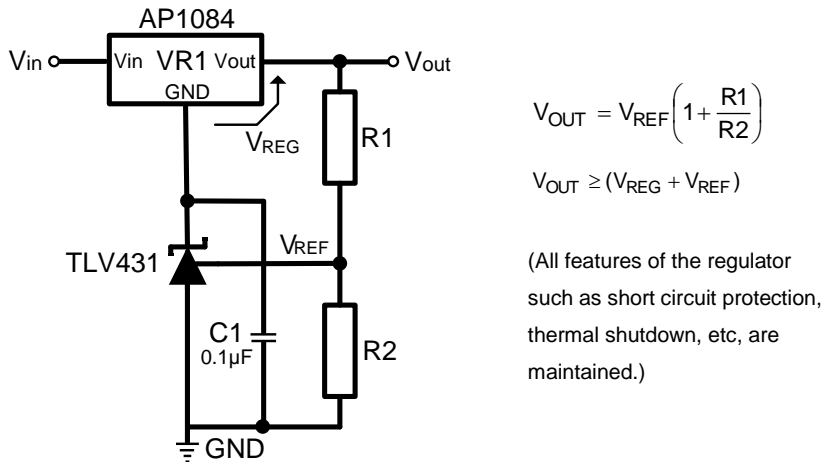

$$V_{OUT} = V_{REF} \left(1 + \frac{R1}{R2} \right)$$

$$V_{OUT} \geq (V_{REG} + V_{REF})$$

(All features of the regulator such as short circuit protection, thermal shutdown, etc, are maintained.)

Figure 6. Increasing Output Voltage of a Fixed Linear Regulator

One of the useful applications of the TLV431 is to improve the accuracy and/or extend the range and flexibility of fixed-voltage regulators. In the Figure 6 circuit, both the output voltage and its accuracy are entirely determined by the TLV431, R1, and R2. However, the rest of the features of the regulator (up to 5A output current, output current limiting, and thermal shutdown) are all still available.

Application Notes (continued)

Printed Circuit Board Layout Considerations (continued)

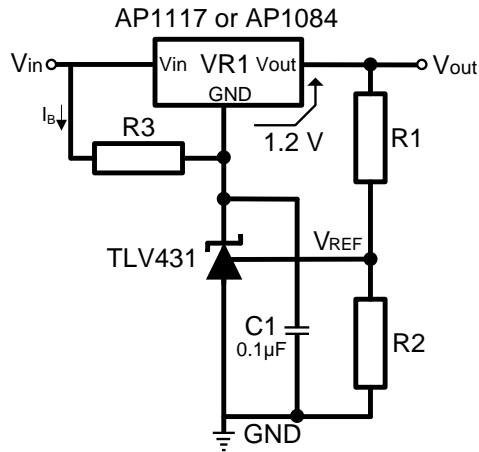

$$V_{OUT} = V_{REF} \left(1 + \frac{R1}{R2} \right)$$

$$V_{OUT} \geq (V_{REG} + V_{REF})$$

$$R3 = \frac{V_{IN} - (V_{OUT} - V_{REG})}{I_B}$$

$$0.1\text{mA} \leq I_B \leq 18\text{mA}$$

(All features of the regulator such as short circuit protection, thermal shutdown, etc, are maintained.)

Figure 7. Adjustable Linear Voltage Regulator

Figure 7 is similar to Figure 6 with adjustability added. Note the addition of R3. This is only required for the AP1117 due to the fact that its ground or adjustment pin can only supply a few mA of current at best. Therefore, R3 must provide sufficient bias current for the TLV431.

Ordering Information

Tol.	Part Number	Package	Part Mark	Status	Reel Size	Tape Width	Packing	
							Qty.	Carrier
1%	TLV431AE5TA	SOT25	V1A	Active	7", 180mm	8mm	3000	Reel
	TLV431AFTA	SOT23	V1A	Active	7", 180mm	8mm	3000	Reel
	TLV431AH6TA	SC70-6 (SOT363)	V1A	Active	7", 180mm	8mm	3000	Reel
0.5%	TLV431BE5TA	SOT25	V1B	Active	7", 180mm	8mm	3000	Reel
	TLV431BFTA	SOT23	V1B	Active	7", 180mm	8mm	3000	Reel
	TLV431BH6TA	SC70-6 (SOT363)	V1B	Active	7", 180mm	8mm	3000	Reel
0.2%	TLV431TFTA	SOT23	V1T	Active	7", 180mm	8mm	3000	Reel

Marking Information

(1) SOT23

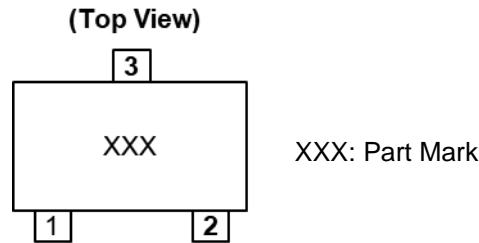

(2) SOT25

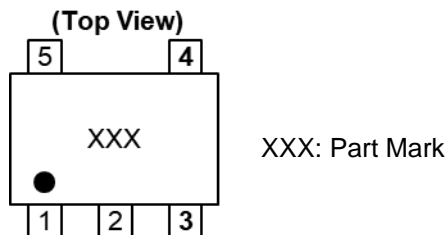

(3) SOT363

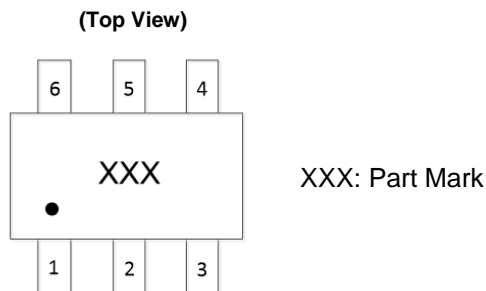

Package Outline Dimensions

Please see <http://www.diodes.com/package-outlines.html> for the latest version.

SOT23

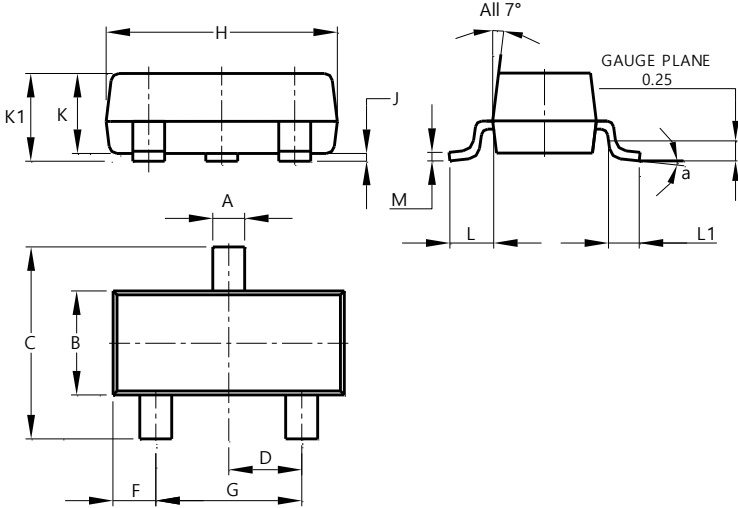

SOT23			
Dim	Min	Max	Typ
A	0.37	0.51	0.40
B	1.20	1.40	1.30
C	2.30	2.50	2.40
D	0.89	1.03	0.915
F	0.45	0.60	0.535
G	1.78	2.05	1.83
H	2.80	3.00	2.90
J	0.013	0.10	0.05
K	0.890	1.00	0.975
K1	0.903	1.10	1.025
L	0.45	0.61	0.55
L1	0.25	0.55	0.40
M	0.085	0.150	0.110
a	0°	8°	--
All Dimensions in mm			

SOT25

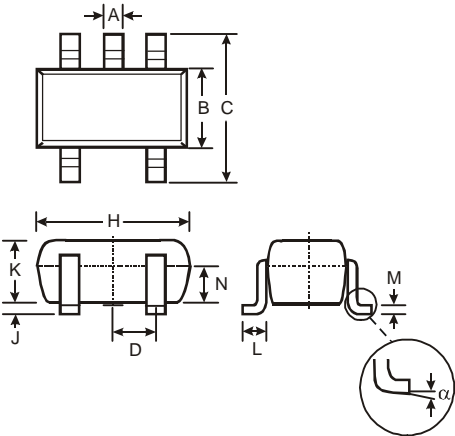

SOT25			
Dim	Min	Max	Typ
A	0.35	0.50	0.38
B	1.50	1.70	1.60
C	2.70	3.00	2.80
D	-	-	0.95
H	2.90	3.10	3.00
J	0.013	0.10	0.05
K	1.00	1.30	1.10
L	0.35	0.55	0.40
M	0.10	0.20	0.15
N	0.70	0.80	0.75
α	0°	8°	-
All Dimensions in mm			

Package Outline Dimensions (continued)

Please see <http://www.diodes.com/package-outlines.html> for the latest version.

SOT363

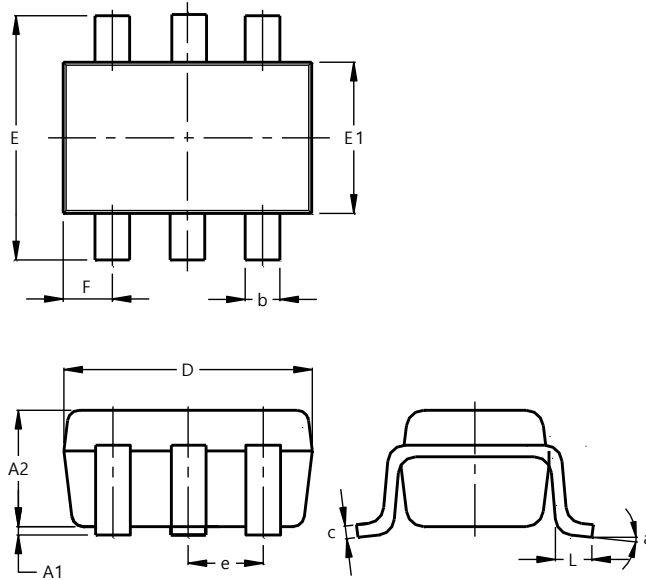

SOT363			
Dim	Min	Max	Typ
A1	0.00	0.10	0.05
A2	0.90	1.00	0.95
b	0.10	0.30	0.25
c	0.10	0.22	0.11
D	1.80	2.20	2.15
E	2.00	2.20	2.10
E1	1.15	1.35	1.30
e	0.650 BSC		
F	0.40	0.45	0.425
L	0.25	0.40	0.30
a	0°	8°	--
All Dimensions in mm			

Suggested Pad Layout

Please see <http://www.diodes.com/package-outlines.html> for the latest version.

SOT23

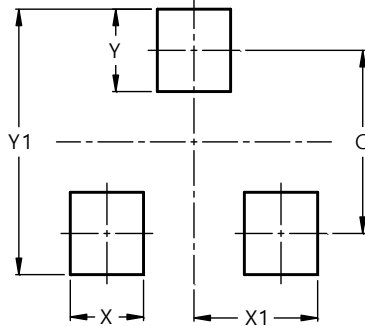

Dimensions	Value (in mm)
C	2.0
X	0.8
X1	1.35
Y	0.9
Y1	2.9

SOT25

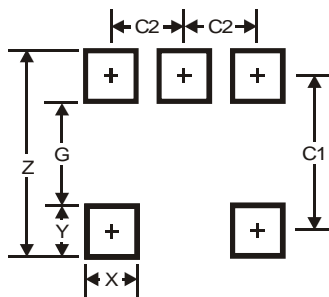

Dimensions	Value
Z	3.20
G	1.60
X	0.55
Y	0.80
C1	2.40
C2	0.95

SOT363

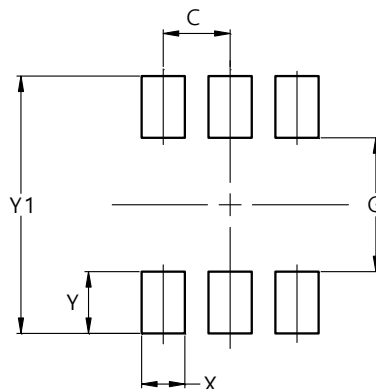

Dimensions	Value (in mm)
C	0.650
G	1.300
X	0.420
Y	0.600
Y1	2.500

Mechanical Data

(1) SOT23

- Moisture Sensitivity: Level 1 per J-STD-020
- Terminals: Finish – Matte Tin Plated Leads, Solderable per MIL-STD-202, Method 208 (e3)
- Weight: 0.009 grams (Approximate)

(2) SOT25

- Moisture Sensitivity: Level 1 per J-STD-020
- Terminals: Finish – Matte Tin Plated Leads, Solderable per MIL-STD-202, Method 208 (e3)
- Weight: 0.016 grams (Approximate)

(3) SOT363

- Moisture Sensitivity: Level 1 per J-STD-020
- Terminals: Finish – Matte Tin Plated Leads, Solderable per MIL-STD-202, Method 208 (e3)
- Weight: 0.006 grams (Approximate)

IMPORTANT NOTICE

1. DIODES INCORPORATED (Diodes) AND ITS SUBSIDIARIES MAKE NO WARRANTY OF ANY KIND, EXPRESS OR IMPLIED, WITH REGARDS TO ANY INFORMATION CONTAINED IN THIS DOCUMENT, INCLUDING, BUT NOT LIMITED TO, THE IMPLIED WARRANTIES OF MERCHANTABILITY, FITNESS FOR A PARTICULAR PURPOSE OR NON-INFRINGEMENT OF THIRD PARTY INTELLECTUAL PROPERTY RIGHTS (AND THEIR EQUIVALENTS UNDER THE LAWS OF ANY JURISDICTION).
2. The Information contained herein is for informational purpose only and is provided only to illustrate the operation of Diodes' products described herein and application examples. Diodes does not assume any liability arising out of the application or use of this document or any product described herein. This document is intended for skilled and technically trained engineering customers and users who design with Diodes' products. Diodes' products may be used to facilitate safety-related applications; however, in all instances customers and users are responsible for (a) selecting the appropriate Diodes products for their applications, (b) evaluating the suitability of Diodes' products for their intended applications, (c) ensuring their applications, which incorporate Diodes' products, comply the applicable legal and regulatory requirements as well as safety and functional-safety related standards, and (d) ensuring they design with appropriate safeguards (including testing, validation, quality control techniques, redundancy, malfunction prevention, and appropriate treatment for aging degradation) to minimize the risks associated with their applications.
3. Diodes assumes no liability for any application-related information, support, assistance or feedback that may be provided by Diodes from time to time. Any customer or user of this document or products described herein will assume all risks and liabilities associated with such use, and will hold Diodes and all companies whose products are represented herein or on Diodes' websites, harmless against all damages and liabilities.
4. Products described herein may be covered by one or more United States, international or foreign patents and pending patent applications. Product names and markings noted herein may also be covered by one or more United States, international or foreign trademarks and trademark applications. Diodes does not convey any license under any of its intellectual property rights or the rights of any third parties (including third parties whose products and services may be described in this document or on Diodes' website) under this document.
5. Diodes' products are provided subject to Diodes' Standard Terms and Conditions of Sale (<https://www.diodes.com/about/company/terms-and-conditions/terms-and-conditions-of-sales/>) or other applicable terms. This document does not alter or expand the applicable warranties provided by Diodes. Diodes does not warrant or accept any liability whatsoever in respect of any products purchased through unauthorized sales channel.
6. Diodes' products and technology may not be used for or incorporated into any products or systems whose manufacture, use or sale is prohibited under any applicable laws and regulations. Should customers or users use Diodes' products in contravention of any applicable laws or regulations, or for any unintended or unauthorized application, customers and users will (a) be solely responsible for any damages, losses or penalties arising in connection therewith or as a result thereof, and (b) indemnify and hold Diodes and its representatives and agents harmless against any and all claims, damages, expenses, and attorney fees arising out of, directly or indirectly, any claim relating to any noncompliance with the applicable laws and regulations, as well as any unintended or unauthorized application.
7. While efforts have been made to ensure the information contained in this document is accurate, complete and current, it may contain technical inaccuracies, omissions and typographical errors. Diodes does not warrant that information contained in this document is error-free and Diodes is under no obligation to update or otherwise correct this information. Notwithstanding the foregoing, Diodes reserves the right to make modifications, enhancements, improvements, corrections or other changes without further notice to this document and any product described herein. This document is written in English but may be translated into multiple languages for reference. Only the English version of this document is the final and determinative format released by Diodes.
8. Any unauthorized copying, modification, distribution, transmission, display or other use of this document (or any portion hereof) is prohibited. Diodes assumes no responsibility for any losses incurred by the customers or users or any third parties arising from any such unauthorized use.
9. This Notice may be periodically updated with the most recent version available at <https://www.diodes.com/about/company/terms-and-conditions/important-notice>

The Diodes logo is a registered trademark of Diodes Incorporated in the United States and other countries.
All other trademarks are the property of their respective owners.
© 2024 Diodes Incorporated. All Rights Reserved.

www.diodes.com

Looking for pricing, stock, or lifecycle information?

Click below to explore more details on WIN SOURCE:

-  [View TLV431BFTA on WIN SOURCE](#)
-  [Diodes Incorporated Information](#)

Optimize Your Supply Chain with WIN SOURCE Solutions

-  Global Sourcing Solution
-  Obsolete Management
-  Cost Control Management
-  Shortage Management
-  Alternative Solution
-  Excess Inventory Management