



**THE DATASHEET OF
TLV5628CDWR**



TLV5628C, TLV5628I OCTAL 8-BIT DIGITAL-TO-ANALOG CONVERTERS

SLAS108A – JANUARY 1995 – REVISED NOVEMBER 1995

- Eight 8-Bit Voltage Output DACs
- 3-V Single Supply Operation
- Serial Interface
- High-Impedance Reference Inputs
- Programmable for 1 or 2 Times Output Range
- Simultaneous Update Facility
- Internal Power-On Reset
- Low Power Consumption
- Half-Buffered Output

DW OR N PACKAGE
(TOP VIEW)

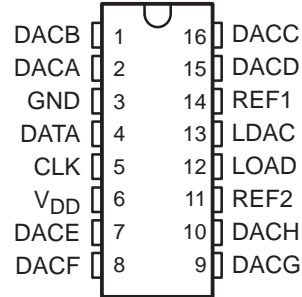

applications

- Programmable Voltage Sources
- Digitally Controlled Amplifiers/Attenuators
- Mobile Communications
- Automatic Test Equipment
- Process Monitoring and Control
- Signal Synthesis

description

The TLV5628C and TLV5628I are octal 8-bit voltage output digital-to-analog converters (DACs) with buffered reference inputs (high impedance). The DACs produce an output voltage that varies between one or two times the reference voltages and GND, and the DACs are monotonic. The device is simple to use, running from a single supply of 3 to 3.6 V. A power-on reset function is incorporated to ensure repeatable start-up conditions.

Digital control of the TLV5628C and TLV5628I is over a simple 3-wire serial bus that is CMOS compatible and easily interfaced to all popular microprocessor and microcontroller devices. The 12-bit command word comprises 8 bits of data, 3 DAC select bits and a range bit, the latter allowing selection between the times 1 or times 2 output range. The DAC registers are double buffered, allowing a complete set of new values to be written to the device, then all DAC outputs are updated simultaneously through control of the LDAC terminal. The digital inputs feature Schmitt triggers for high noise immunity.

The 16-terminal small-outline D package allows digital control of analog functions in space-critical applications. The TLV5628C is characterized for operation from 0°C to 70°C. The TLV5628I is characterized for operation from -40°C to 85°C. The TLV5628C and TLV5628I do not require external trimming.

AVAILABLE OPTIONS

T _A	PACKAGE	
	SMALL OUTLINE (DW)	PLASTIC DIP (N)
0°C to 70°C	TLV5628CDW	TLV5628CN
-40°C to 85°C	TLV5628IDW	TLV5628IN



Please be aware that an important notice concerning availability, standard warranty, and use in critical applications of Texas Instruments semiconductor products and disclaimers thereto appears at the end of this data sheet.

PRODUCTION DATA information is current as of publication date. Products conform to specifications per the terms of Texas Instruments standard warranty. Production processing does not necessarily include testing of all parameters.

 **TEXAS
INSTRUMENTS**

POST OFFICE BOX 655303 • DALLAS, TEXAS 75265

Copyright © 1995, Texas Instruments Incorporated

TLV5628C, TLV5628I OCTAL 8-BIT DIGITAL-TO-ANALOG CONVERTERS

SLAS108A – JANUARY 1995 – REVISED NOVEMBER 1995

functional block diagram

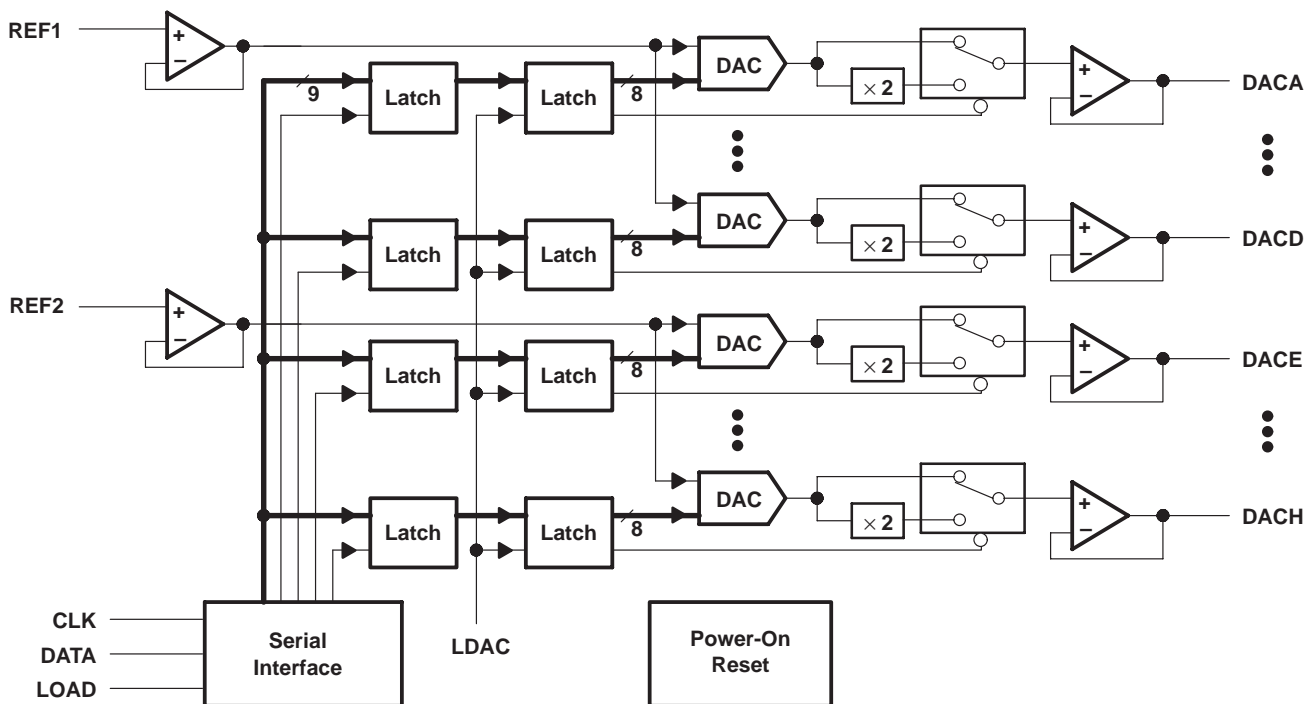

Terminal Functions

TERMINAL NAME	NO.	I/O	DESCRIPTION
CLK	5	I	Serial-interface clock, data enters on the negative edge
DACA	2	O	DACA analog output
DACB	1	O	DACB analog output
DACC	16	O	DACC analog output
DACD	15	O	DACD analog output
DACE	7	O	DACE analog output
DACF	8	O	DACF analog output
DACG	9	O	DACG analog output
DACH	10	O	DACH analog output
DATA	4	I	Serial-interface digital data input
GND	3	I	Ground return and reference terminal
LDAC	13	I	DAC-update latch control
LOAD	12	I	Serial-interface load control
REF1	14	I	Reference voltage input to DACA
REF2	11	I	Reference voltage input to DACB
VDD	6	I	Positive supply voltage

detailed description

The TLV5628 is implemented using eight resistor-string DACs. The core of each DAC is a single resistor with 256 taps, corresponding to the 256 possible codes listed in Table 1. One end of each resistor string is connected to the GND terminal and the other end is fed from the output of the reference input buffer. Monotonicity is maintained by use of the resistor strings. Linearity depends upon the matching of the resistor elements and upon the performance of the output buffer. Because the inputs are buffered, the DACs always present a high-impedance load to the reference sources. There are two input reference terminals; REF1 is used for DACA through DACD and REF2 is used by DACE through DACH.

Each DAC output is buffered by a configurable-gain output amplifier, which can be programmed to times 1 or times 2 gain.

On power-up, the DACs are reset to CODE 0.

Each output voltage is given by:

$$V_O(\text{DACA|B|C|D|E|F|G|H}) = \text{REF} \times \frac{\text{CODE}}{256} \times (1 + \text{RNG bit value})$$

where CODE is in the range of 0 to 255 and the range (RNG) bit is a 0 or 1 within the serial-control word.

data interface

With LOAD high, data is clocked into the DATA terminal on each falling edge of CLK. Once all data bits have been clocked in, LOAD is pulsed low to transfer the data from the serial-input register to the selected DAC as shown in Figure 1. When LDAC is low, the selected DAC output voltage is updated and LOAD goes low. When LDAC is high during serial programming, the new value is stored within the device and can be transferred to the DAC output at a later time by pulsing LDAC low as shown in Figure 2. Data is entered MSB first. Data transfers using two 8 clock cycle periods are shown in Figures 3 and 4.

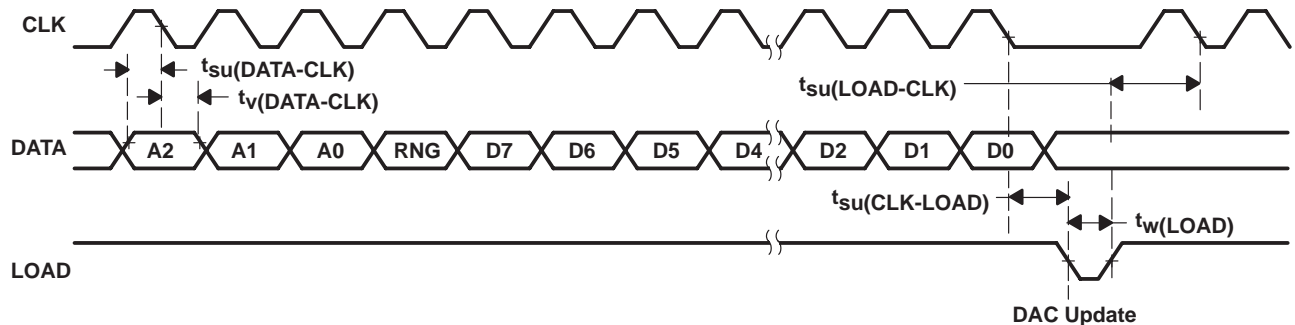

Figure 1. LOAD-Controlled Update (LDAC = Low)

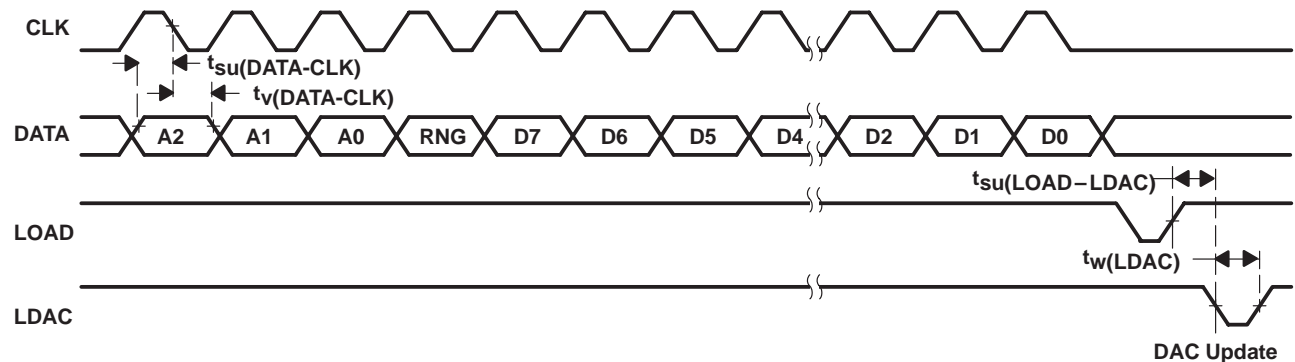

Figure 2. LDAC-Controlled Update

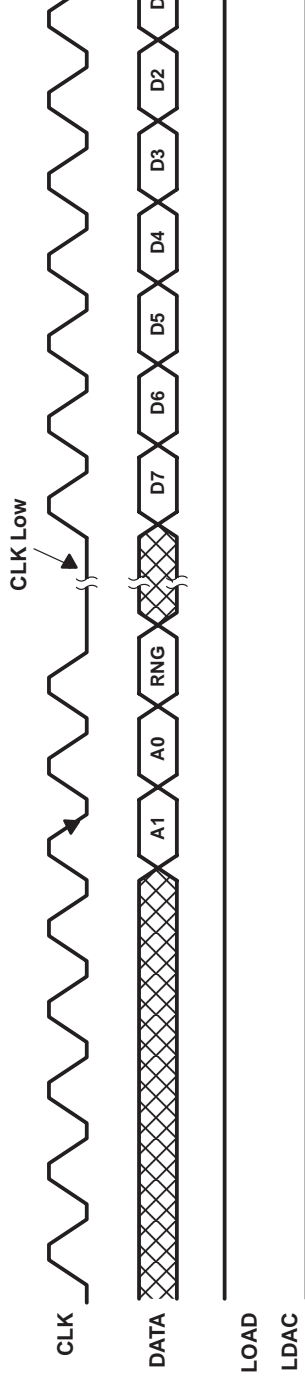

Figure 3. Load Controlled Update Using 8-Bit Serial Word (LDAC = Low)

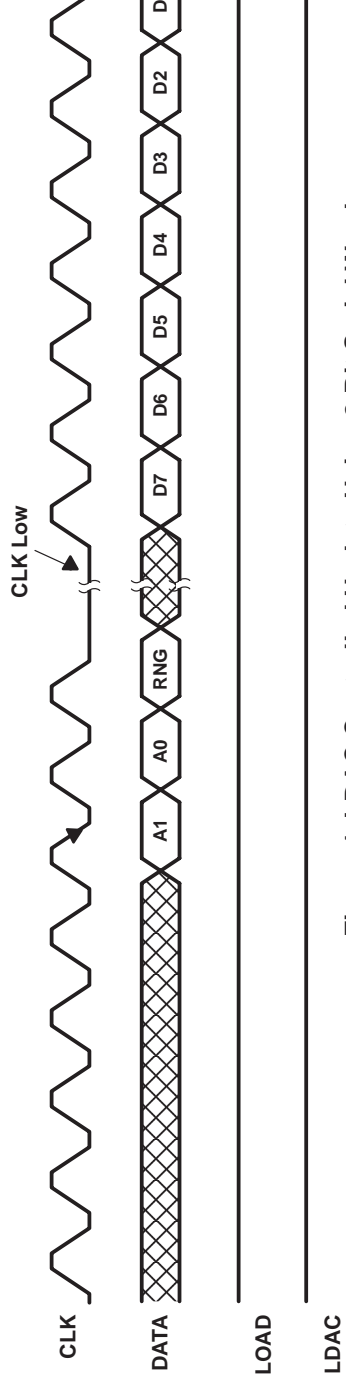

Figure 4. LDAC Controlled Update Using 8-Bit Serial Word

data interface (continued)

Table 2 lists the A2, A1, and A0 bits and the selection of the updated DACs. The RNG bit controls the DAC output range. When RNG = low, the output range is between the applied reference voltage and GND, and when RNG = high, the range is between twice the applied reference voltage and GND.

Table 1. Ideal Output Transfer

D7	D6	D5	D4	D3	D2	D1	D0	OUTPUT VOLTAGE
0	0	0	0	0	0	0	0	GND
0	0	0	0	0	0	0	1	$(1/256) \times \text{REF} (1+\text{RNG})$
•	•	•	•	•	•	•	•	•
•	•	•	•	•	•	•	•	•
0	1	1	1	1	1	1	1	$(127/256) \times \text{REF} (1+\text{RNG})$
1	0	0	0	0	0	0	0	$(128/256) \times \text{REF} (1+\text{RNG})$
•	•	•	•	•	•	•	•	•
•	•	•	•	•	•	•	•	•
1	1	1	1	1	1	1	1	$(255/256) \times \text{REF} (1+\text{RNG})$

Table 2. Serial Input Decode

A2	A1	A0	DAC UPDATED
0	0	0	DACA
0	0	1	DACB
0	1	0	DACC
0	1	1	DACD
1	0	0	DACE
1	0	1	DACF
1	1	0	DACG
1	1	1	DACH

TLV5628C, TLV5628I OCTAL 8-BIT DIGITAL-TO-ANALOG CONVERTERS

SLAS108A – JANUARY 1995 – REVISED NOVEMBER 1995

linearity, offset, and gain error

When an amplifier is operated from a single supply, the voltage offset can still be either positive or negative. With a positive offset, the output voltage changes on the first code change. With a negative offset the output voltage may not change with the first code depending on the magnitude of the offset voltage.

The output amplifier, with a negative voltage offset, attempts to drive the output to a negative voltage. However, since the most negative supply rail is ground, the output cannot drive to a negative voltage.

So when the output offset voltage is negative, the output voltage remains at 0 volts until the input code value produces a sufficient output voltage to overcome the inherent negative offset voltage resulting in the transfer function shown in Figure 5.

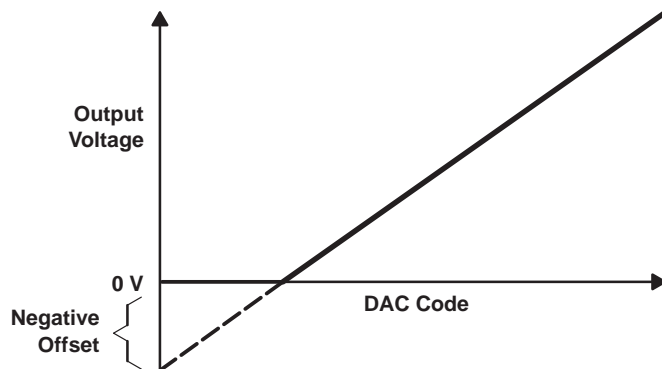

Figure 5. Effect of Negative Offset (Single Supply)

The negative offset error produces a breakpoint, not a linearity error. The transfer function would follow the dotted line if the output buffer could drive to a negative voltage.

For a DAC, linearity is measured between zero input code (all inputs 0) and full scale code (all inputs 1) after offset and full scale is adjusted out or accounted for in some way. However, single supply operation does not allow for adjustment when the offset is negative due to the breakpoint in the transfer function. The linearity in the unipolar mode is measured between full scale code and the lowest code which produces a positive output voltage.

The code is calculated from the maximum specification for the negative offset.

equivalent inputs and outputs

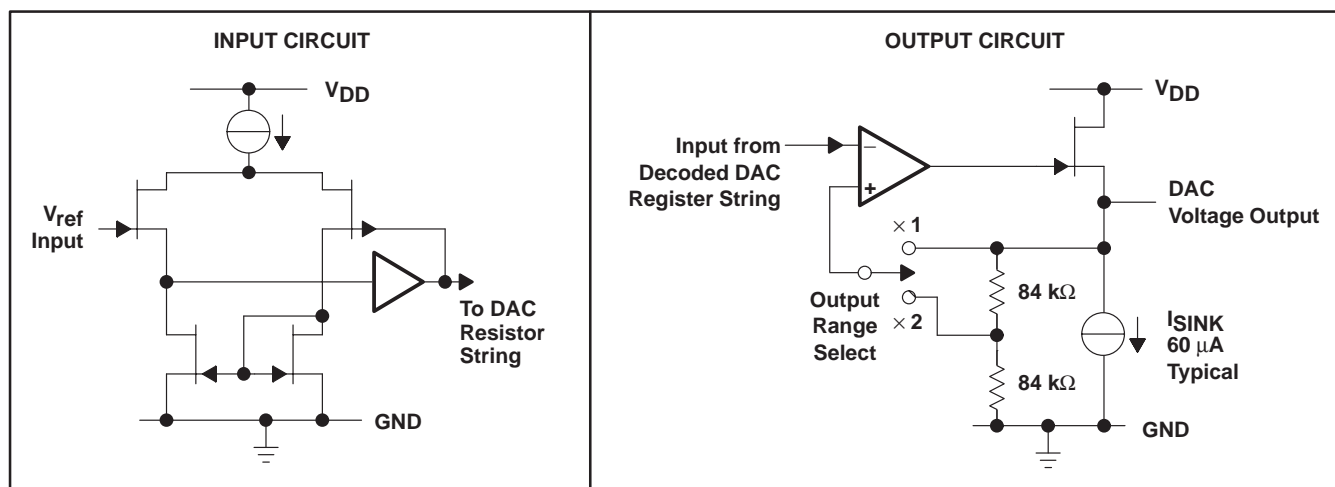

TLV5628C, TLV5628I OCTAL 8-BIT DIGITAL-TO-ANALOG CONVERTERS

SLAS108A – JANUARY 1995 – REVISED NOVEMBER 1995

absolute maximum ratings over operating free-air temperature range (unless otherwise noted)†

Supply voltage ($V_{DD} - GND$)	7 V
Digital input voltage range, V_{ID}	GND – 0.3 V to $V_{DD} + 0.3$ V
Reference input voltage range	GND – 0.3 V to $V_{DD} + 0.3$ V
Operating free-air temperature range, T_A : TLV5628C	0°C to 70°C
TLV5628I	–40°C to 85°C
Storage temperature range, T_{stg}	–50°C to 150°C
Lead temperature 1,6 mm (1/16 inch) from case for 10 seconds	230°C

† Stresses beyond those listed under “absolute maximum ratings” may cause permanent damage to the device. These are stress ratings only, and functional operation of the device at these or any other conditions beyond those indicated under “recommended operating conditions” is not implied. Exposure to absolute-maximum-rated conditions for extended periods may affect device reliability.

recommended operating conditions

	MIN	NOM	MAX	UNIT	
Supply voltage, V_{DD}	2.7	3.3	5.25	V	
High-level digital input voltage, V_{IH}	$0.8 V_{DD}$			V	
Low-level digital input voltage, V_{IL}	0.8			V	
Reference voltage, V_{ref} [A B C D E F G H], X1 gain	$V_{DD} - 1.5$			V	
Load resistance, R_L	10			k Ω	
Setup time, data input, $t_{su}(DATA-CLK)$ (see Figures 1 and 2)	50			ns	
Valid time, data input valid after $CLK\downarrow$, $t_v(DATA-CLK)$ (see Figures 1 and 2)	50			ns	
Setup time, CLK eleventh falling edge to LOAD, $t_{su}(CLK-LOAD)$ (see Figure 1)	50			ns	
Setup time, $LOAD\uparrow$ to $CLK\downarrow$, $t_{su}(LOAD-CLK)$ (see Figure 1)	50			ns	
Pulse duration, LOAD, $t_w(LOAD)$ (see Figure 1)	250			ns	
Pulse duration, LDAC, $t_w(LDAC)$ (see Figure 2)	250			ns	
Setup time, $LOAD\uparrow$ to $LDAC\downarrow$, $t_{su}(LOAD-LDAC)$ (see Figure 2)	0			ns	
CLK frequency	1			MHz	
Operating free-air temperature, T_A	TLV5628C		0	70	°C
	TLV5628I		–40	85	°C



TLV5628C, TLV5628I

OCTAL 8-BIT DIGITAL-TO-ANALOG CONVERTERS

SLAS108A – JANUARY 1995 – REVISED NOVEMBER 1995

electrical characteristics over recommended operating free-air temperature range, $V_{DD} = 3\text{ V to }3.6\text{ V}$, $V_{ref} = 2\text{ V}$, $\times 1$ gain output range (unless otherwise noted)

PARAMETER		TEST CONDITIONS	MIN	TYP	MAX	UNIT
I_{IH}	High-level digital input current	$V_I = V_{DD}$			± 10	μA
I_{IL}	Low-level digital input current	$V_I = 0\text{ V}$			± 10	μA
$I_{O(sink)}$	Output sink current	Each DAC output	20			μA
$I_{O(source)}$	Output source current		1			mA
C_i	Input capacitance			15		pF
	Reference input capacitance			15		
I_{DD}	Supply current	$V_{DD} = 3.3\text{ V}$			4	mA
I_{ref}	Reference input current	$V_{DD} = 3.3\text{ V}$, $V_{ref} = 1.5\text{ V}$			± 10	μA
E_L	Linearity error (end point corrected)	$V_{ref} = 1.25\text{ V}$, $\times 2$ gain (see Note 1)			± 1	LSB
E_D	Differential linearity error	$V_{ref} = 1.25\text{ V}$, $\times 2$ gain (see Note 2)			± 0.9	LSB
E_{ZS}	Zero-scale error	$V_{ref} = 1.25\text{ V}$, $\times 2$ gain (see Note 3)	0		30	mV
	Zero-scale error temperature coefficient	$V_{ref} = 1.25\text{ V}$, $\times 2$ gain (see Note 4)		10		$\mu\text{V}/^\circ\text{C}$
E_{FS}	Full-scale error	$V_{ref} = 1.25\text{ V}$, $\times 2$ gain (see Note 5)			± 60	mV
	Full-scale error temperature coefficient	$V_{ref} = 1.25\text{ V}$, $\times 2$ gain (see Note 6)		± 25		$\mu\text{V}/^\circ\text{C}$
PSRR	Power supply sensitivity	See Notes 7 and 8		0.5		mV/V

- NOTES: 1. Integral nonlinearity (INL) is the maximum deviation of the output from the line between zero-scale and full scale (excluding the effects of zero code and full-scale errors).
2. Differential nonlinearity (DNL) is the difference between the measured and ideal 1 LSB amplitude change of any two adjacent codes. Monotonic means the output voltage changes in the same direction (or remains constant) as a change in the digital input code.
3. Zero-scale error is the deviation from zero voltage output when the digital input code is zero.
4. Zero-scale error temperature coefficient is given by: $ZSETC = [ZSE(T_{max}) - ZSE(T_{min})]/V_{ref} \times 10^6/(T_{max} - T_{min})$.
5. Full-scale error is the deviation from the ideal full-scale output ($V_{ref} - 1\text{ LSB}$) with an output load of $10\text{ k}\Omega$.
6. Full-scale temperature coefficient is given by: $FSETC = [FSE(T_{max}) - FSE(T_{min})]/V_{ref} \times 10^6/(T_{max} - T_{min})$.
7. Zero-scale error rejection ratio (ZSE-RR) is measured by varying the V_{DD} voltage from 4.5 V to 5.5 V dc and measuring the effect of this signal on the zero-code output voltage.
8. Full-scale error rejection ratio (FSE-RR) is measured by varying the V_{DD} voltage from 3 V to 3.6 V dc and measuring the effect of this signal on the full-scale output voltage.

operating characteristics over recommended operating free-air temperature range, $V_{DD} = 3\text{ V to }3.6\text{ V}$, $V_{ref} = 2\text{ V}$, $\times 1$ gain output range (unless otherwise noted)

	TEST CONDITIONS	MIN	TYP	MAX	UNIT
Output slew rate	$C_L = 100\text{ pF}$, $R_L = 10\text{ k}\Omega$		1		$\text{V}/\mu\text{s}$
Output settling time	To 0.5 LSB, $C_L = 100\text{ pF}$, $R_L = 10\text{ k}\Omega$, See Note 9		10		μs
Large-signal bandwidth	Measured at -3 dB point		100		kHz
Digital crosstalk	$\text{CLK} = 1\text{-MHz}$ square wave measured at DACA-DACH		-50		dB
Reference feedthrough	See Note 10		-60		dB
Channel-to-channel isolation	See Note 11		-60		dB
Reference input bandwidth	See Note 12		100		kHz

- NOTES: 9. Settling time is the time for the output signal to remain within $\pm 0.5\text{ LSB}$ of the final measured value for a digital input code change of 00 hex to FF hex or FF hex to 00 hex. For TLC5628C $V_{DD} = 5\text{ V}$, $V_{ref} = 2\text{ V}$ and range = $\times 2$. For TLC5628I $V_{DD} = 3\text{ V}$, $V_{ref} = 1.25\text{ V}$ and range $\times 2$.
10. Reference feedthrough is measured at any DAC output with an input code = 00 hex with a V_{ref} input = $1\text{ V dc} + 1\text{ V}_{pp}$ at 10 kHz .
11. Channel-to-channel isolation is measured by setting the input code of one DAC to FF hex and the code of all other DACs to 00 hex with V_{ref} input = $1\text{ V dc} + 1\text{ V}_{pp}$ at 10 kHz .
12. Reference bandwidth is a -3 dB bandwidth with an input at $V_{ref} = 1.25\text{ V dc} + 2\text{ V}_{pp}$ and with a full-scale digital input code.



PARAMETER MEASUREMENT INFORMATION

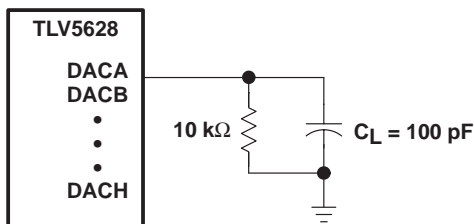
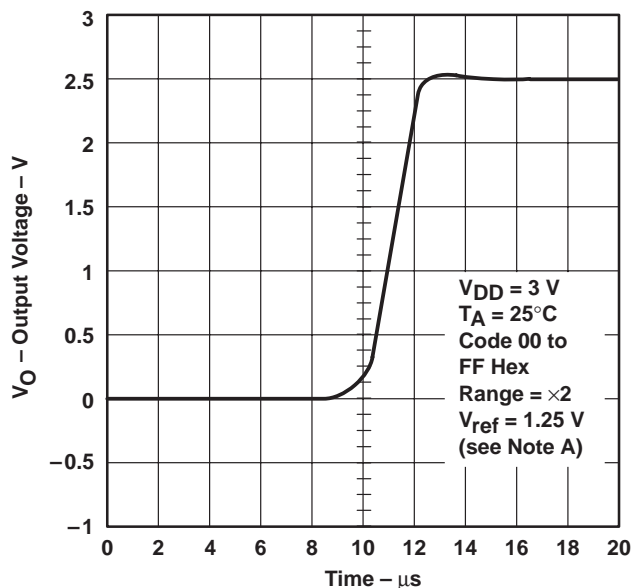

Figure 6. Slewing Settling Time and Linearity Measurements

TYPICAL CHARACTERISTICS

POSITIVE RISE TIME AND SETTLING TIME



NOTE A: Rise time = 2.05 μs , positive slew rate = 0.96 V/ μs , settling time = 4.5 μs .

Figure 7

NEGATIVE FALL TIME AND SETTLING TIME

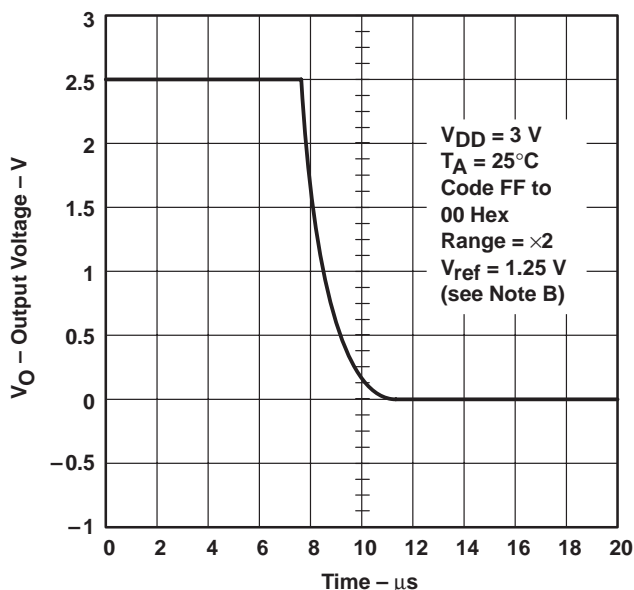

NOTE B: Fall time = 4.25 μs , negative slew rate = 0.46 V/ μs , settling time = 8.5 μs .

Figure 8

TLV5628C, TLV5628I OCTAL 8-BIT DIGITAL-TO-ANALOG CONVERTERS

SLAS108A – JANUARY 1995 – REVISED NOVEMBER 1995

TYPICAL CHARACTERISTICS

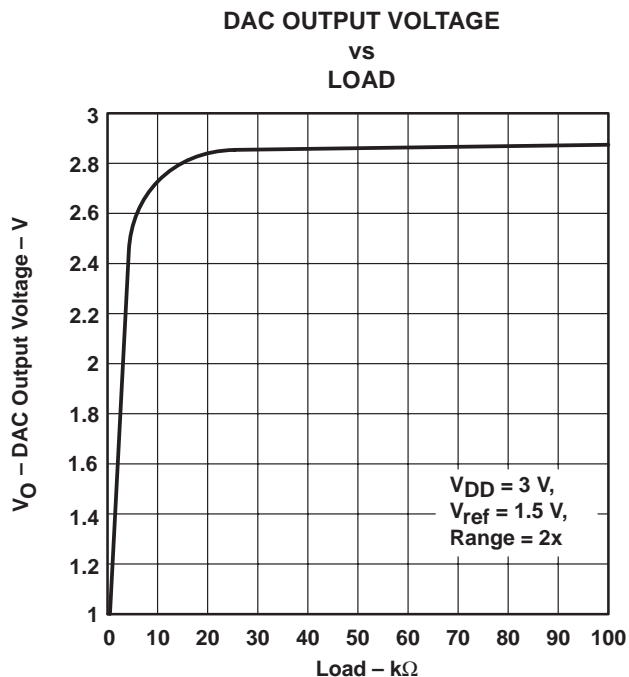

Figure 9

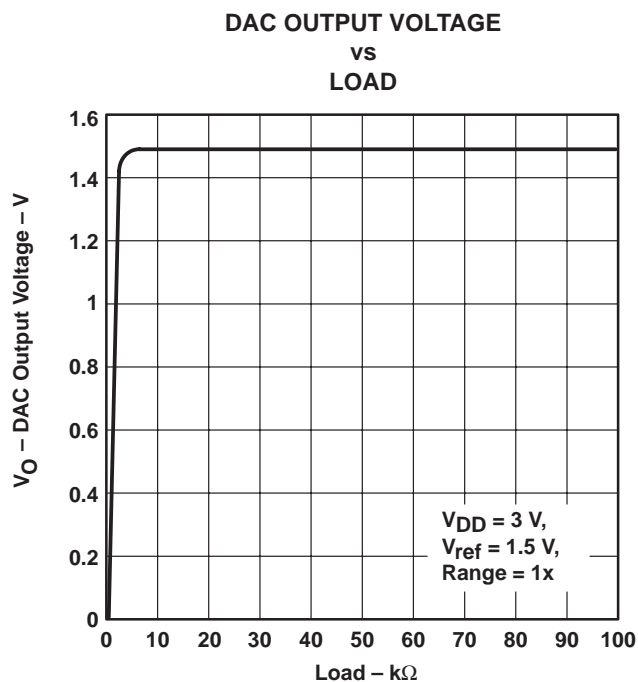

Figure 10

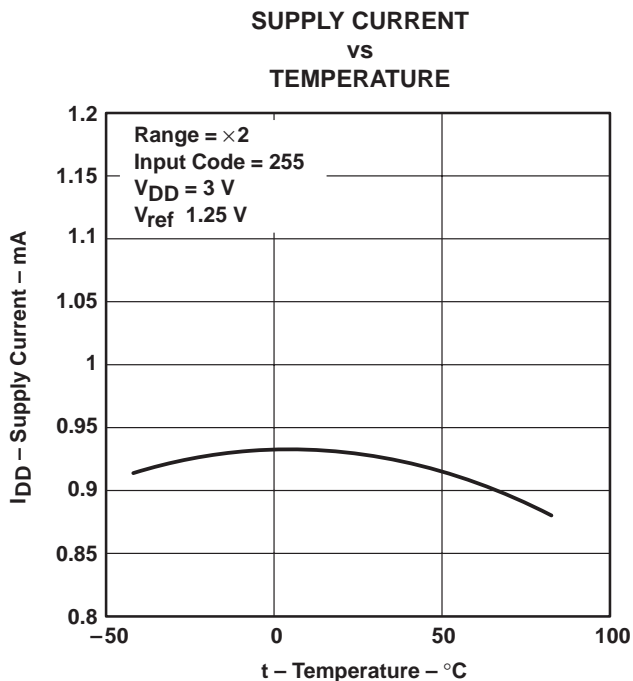
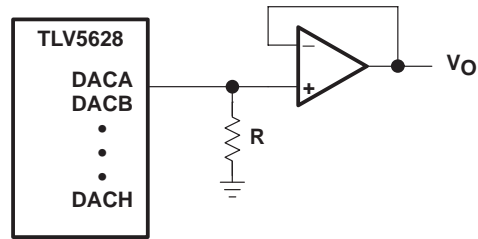

Figure 11



APPLICATION INFORMATION



NOTE A: Resistor $R \geq 10 \text{ k}\Omega$

Figure 12. Output Buffering Scheme

TLV5628C, TLV5628I OCTAL 8-BIT DIGITAL-TO-ANALOG CONVERTERS

SLAS108A – JANUARY 1995 – REVISED NOVEMBER 1995

MECHANICAL DATA

DW (R-PDSO-G**)

PLASTIC SMALL-OUTLINE PACKAGE

16 PIN SHOWN

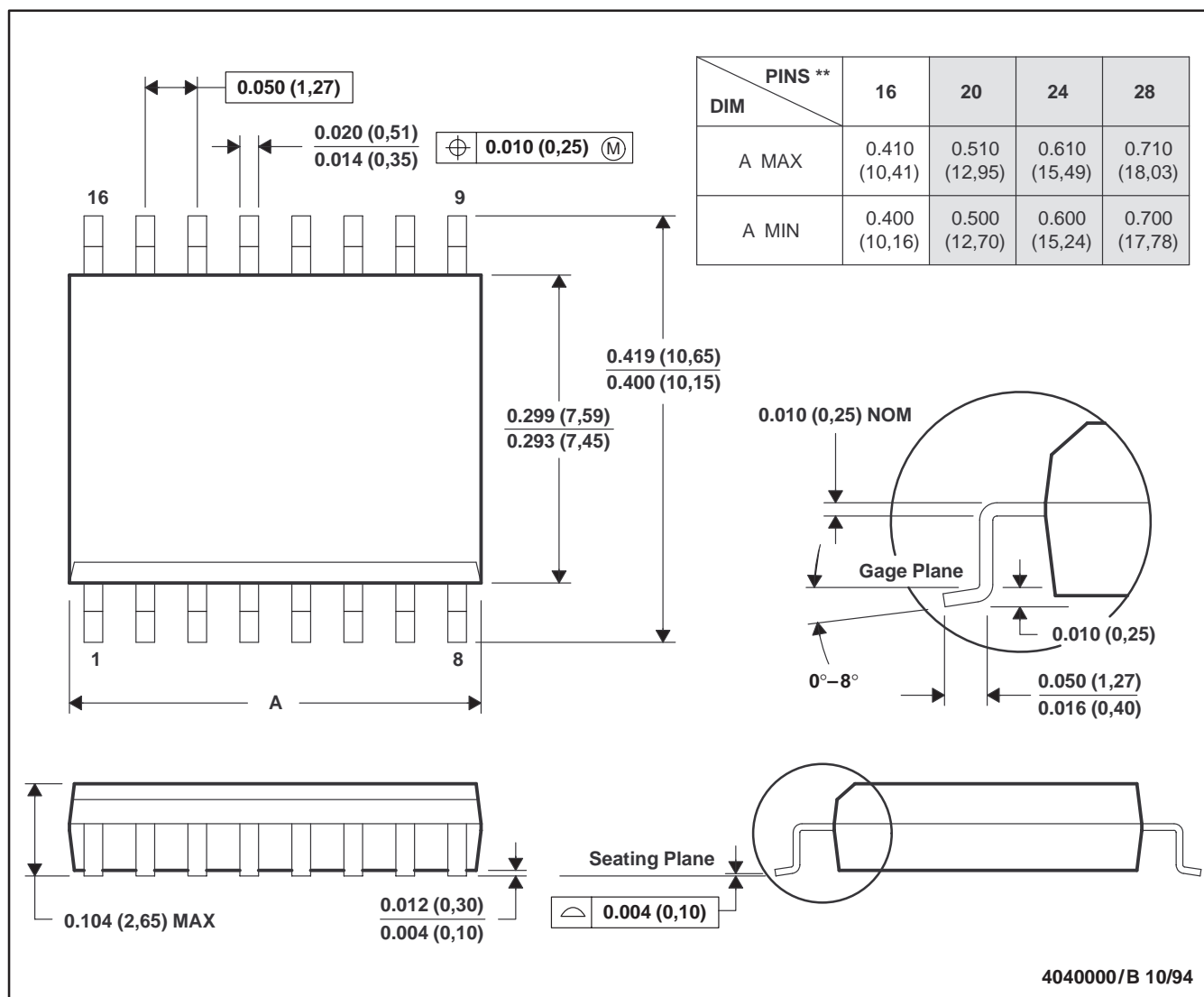

- NOTES:
- A. All linear dimensions are in inches (millimeters).
 - B. This drawing is subject to change without notice.
 - C. Body dimensions do not include mold flash or protrusion not to exceed 0.006 (0,15).
 - D. Falls within JEDEC MS-013

TLV5628C, TLV5628I OCTAL 8-BIT DIGITAL-TO-ANALOG CONVERTERS

SLAS108A – JANUARY 1995 – REVISED NOVEMBER 1995

MECHANICAL DATA

N (R-PDIP-T)**

PLASTIC DUAL-IN-LINE PACKAGE

16 PIN SHOWN

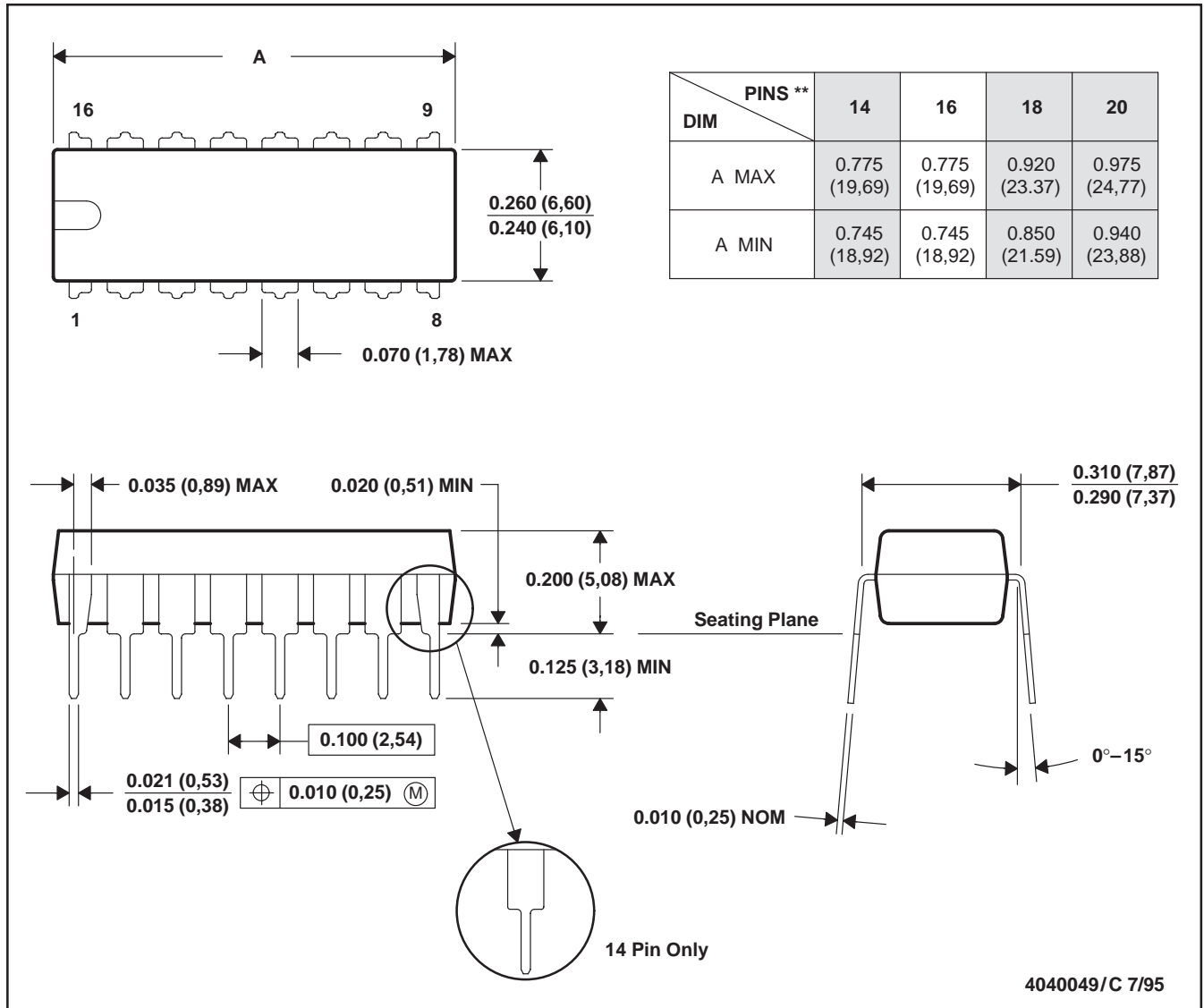

- NOTES: A. All linear dimensions are in inches (millimeters).
 B. This drawing is subject to change without notice.
 C. Falls within JEDEC MS-001 (20-pin package is shorter than MS-001)

PACKAGING INFORMATION

Orderable Device	Status (1)	Package Type	Package Drawing	Pins	Package Qty	Eco Plan (2)	Lead finish/ Ball material (6)	MSL Peak Temp (3)	Op Temp (°C)	Device Marking (4/5)	Samples
TLV5628CDW	ACTIVE	SOIC	DW	16	40	RoHS & Green	NIPDAU	Level-1-260C-UNLIM	0 to 70	TLV5628C	Samples
TLV5628CDWR	ACTIVE	SOIC	DW	16	2000	RoHS & Green	NIPDAU	Level-1-260C-UNLIM		TLV5628C	Samples
TLV5628CN	ACTIVE	PDIP	N	16	25	RoHS & Green	NIPDAU	N / A for Pkg Type		TLV5628CN	Samples
TLV5628IDW	ACTIVE	SOIC	DW	16	40	RoHS & Green	NIPDAU	Level-1-260C-UNLIM	-40 to 85	TLV5628I	Samples
TLV5628IDWG4	ACTIVE	SOIC	DW	16	40	RoHS & Green	NIPDAU	Level-1-260C-UNLIM	-40 to 85	TLV5628I	Samples
TLV5628IDWR	ACTIVE	SOIC	DW	16	2000	RoHS & Green	NIPDAU	Level-1-260C-UNLIM		TLV5628I	Samples
TLV5628IDWRG4	ACTIVE	SOIC	DW	16	2000	RoHS & Green	NIPDAU	Level-1-260C-UNLIM		TLV5628I	Samples
TLV5628IN	ACTIVE	PDIP	N	16	25	RoHS & Green	NIPDAU	N / A for Pkg Type		TLV5628IN	Samples

(1) The marketing status values are defined as follows:

ACTIVE: Product device recommended for new designs.

LIFEBUY: TI has announced that the device will be discontinued, and a lifetime-buy period is in effect.

NRND: Not recommended for new designs. Device is in production to support existing customers, but TI does not recommend using this part in a new design.

PREVIEW: Device has been announced but is not in production. Samples may or may not be available.

OBSELETE: TI has discontinued the production of the device.

(2) **RoHS:** TI defines "RoHS" to mean semiconductor products that are compliant with the current EU RoHS requirements for all 10 RoHS substances, including the requirement that RoHS substance do not exceed 0.1% by weight in homogeneous materials. Where designed to be soldered at high temperatures, "RoHS" products are suitable for use in specified lead-free processes. TI may reference these types of products as "Pb-Free".

RoHS Exempt: TI defines "RoHS Exempt" to mean products that contain lead but are compliant with EU RoHS pursuant to a specific EU RoHS exemption.

Green: TI defines "Green" to mean the content of Chlorine (Cl) and Bromine (Br) based flame retardants meet JS709B low halogen requirements of <=1000ppm threshold. Antimony trioxide based flame retardants must also meet the <=1000ppm threshold requirement.

(3) MSL, Peak Temp. - The Moisture Sensitivity Level rating according to the JEDEC industry standard classifications, and peak solder temperature.

(4) There may be additional marking, which relates to the logo, the lot trace code information, or the environmental category on the device.

(5) Multiple Device Markings will be inside parentheses. Only one Device Marking contained in parentheses and separated by a "-" will appear on a device. If a line is indented then it is a continuation of the previous line and the two combined represent the entire Device Marking for that device.

⁽⁶⁾ Lead finish/Ball material - Orderable Devices may have multiple material finish options. Finish options are separated by a vertical ruled line. Lead finish/Ball material values may wrap to two lines if the finish value exceeds the maximum column width.

Important Information and Disclaimer: The information provided on this page represents TI's knowledge and belief as of the date that it is provided. TI bases its knowledge and belief on information provided by third parties, and makes no representation or warranty as to the accuracy of such information. Efforts are underway to better integrate information from third parties. TI has taken and continues to take reasonable steps to provide representative and accurate information but may not have conducted destructive testing or chemical analysis on incoming materials and chemicals. TI and TI suppliers consider certain information to be proprietary, and thus CAS numbers and other limited information may not be available for release.

In no event shall TI's liability arising out of such information exceed the total purchase price of the TI part(s) at issue in this document sold by TI to Customer on an annual basis.

TAPE AND REEL INFORMATION

QUADRANT ASSIGNMENTS FOR PIN 1 ORIENTATION IN TAPE

*All dimensions are nominal

Device	Package Type	Package Drawing	Pins	SPQ	Reel Diameter (mm)	Reel Width W1 (mm)	A0 (mm)	B0 (mm)	K0 (mm)	P1 (mm)	W (mm)	Pin1 Quadrant
TLV5628CDWR	SOIC	DW	16	2000	330.0	16.4	10.75	10.7	2.7	12.0	16.0	Q1
TLV5628IDWR	SOIC	DW	16	2000	330.0	16.4	10.75	10.7	2.7	12.0	16.0	Q1

TAPE AND REEL BOX DIMENSIONS

*All dimensions are nominal

Device	Package Type	Package Drawing	Pins	SPQ	Length (mm)	Width (mm)	Height (mm)
TLV5628CDWR	SOIC	DW	16	2000	350.0	350.0	43.0
TLV5628IDWR	SOIC	DW	16	2000	350.0	350.0	43.0

TUBE

*All dimensions are nominal

Device	Package Name	Package Type	Pins	SPQ	L (mm)	W (mm)	T (μm)	B (mm)
TLV5628CDW	DW	SOIC	16	40	506.98	12.7	4826	6.6
TLV5628CN	N	PDIP	16	25	506	13.97	11230	4.32
TLV5628IDW	DW	SOIC	16	40	506.98	12.7	4826	6.6
TLV5628IDWG4	DW	SOIC	16	40	506.98	12.7	4826	6.6
TLV5628IN	N	PDIP	16	25	506	13.97	11230	4.32

IMPORTANT NOTICE AND DISCLAIMER

TI PROVIDES TECHNICAL AND RELIABILITY DATA (INCLUDING DATA SHEETS), DESIGN RESOURCES (INCLUDING REFERENCE DESIGNS), APPLICATION OR OTHER DESIGN ADVICE, WEB TOOLS, SAFETY INFORMATION, AND OTHER RESOURCES "AS IS" AND WITH ALL FAULTS, AND DISCLAIMS ALL WARRANTIES, EXPRESS AND IMPLIED, INCLUDING WITHOUT LIMITATION ANY IMPLIED WARRANTIES OF MERCHANTABILITY, FITNESS FOR A PARTICULAR PURPOSE OR NON-INFRINGEMENT OF THIRD PARTY INTELLECTUAL PROPERTY RIGHTS.

These resources are intended for skilled developers designing with TI products. You are solely responsible for (1) selecting the appropriate TI products for your application, (2) designing, validating and testing your application, and (3) ensuring your application meets applicable standards, and any other safety, security, regulatory or other requirements.

These resources are subject to change without notice. TI grants you permission to use these resources only for development of an application that uses the TI products described in the resource. Other reproduction and display of these resources is prohibited. No license is granted to any other TI intellectual property right or to any third party intellectual property right. TI disclaims responsibility for, and you will fully indemnify TI and its representatives against, any claims, damages, costs, losses, and liabilities arising out of your use of these resources.

TI's products are provided subject to [TI's Terms of Sale](#) or other applicable terms available either on [ti.com](https://www.ti.com) or provided in conjunction with such TI products. TI's provision of these resources does not expand or otherwise alter TI's applicable warranties or warranty disclaimers for TI products.

TI objects to and rejects any additional or different terms you may have proposed.

Mailing Address: Texas Instruments, Post Office Box 655303, Dallas, Texas 75265
Copyright © 2023, Texas Instruments Incorporated

Looking for pricing, stock, or lifecycle information?

Click below to explore more details on WIN SOURCE:

 [View TLV5628CDWR on WIN SOURCE](#)

 [Texas Instruments](#) Information

Optimize Your Supply Chain with WIN SOURCE Solutions

-  Global Sourcing Solution
-  Obsolete Management
-  Cost Control Management
-  Shortage Management
-  Alternative Solution
-  Excess Inventory Management