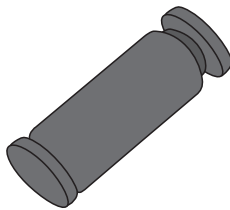


Diac in MINIMELF package with tight V_{BO}


MINIMELF

Features

- V_{BO} : 32 V
- Low breakover voltage: 15 μ A max.
- Breakover voltage range: 30 to 34 V

Applications

- General purpose AC line load switching
- Motor control circuits
- Home appliances
- Heating
- Lighting
- Inrush current limiting circuits
- Overvoltage crowbar protection

Description

Functioning as a trigger diode with a fixed voltage reference, the **TMMDB3TG** can be used in conjunction with Triacs for simplified gate control circuits or as a starting element in fluorescent lamp ballasts.

Product status link

[TMMDB3TG](#)

Product summary

Order code	V_{BO}
TMMDB3TG	30 - 34 V

1 Characteristics

Table 1. Absolute maximum ratings (limiting values), $T_j = 25\text{ °C}$ unless otherwise specified

Symbol	Parameter	Value	Unit
I_{TRM}	Repetitive peak on-state current, $t_p = 20\ \mu s$, $F = 120\text{ Hz}$	2	A
T_{stg}	Storage junction temperature range	-40 to +125	$^{\circ}\text{C}$
T_j	Operating junction temperature range	-40 to +125	$^{\circ}\text{C}$

Table 2. Electrical characteristics ($T_j = 25\text{ °C}$ unless otherwise specified)

Symbol	Parameter	Test conditions	Value	Unit	
V_{BO}	Breakover voltage ⁽¹⁾	$C = 10\text{ nF}^{(2)}$	Min.	30	V
			Typ.	32	
			Max.	34	
$ V_{BO1} - V_{BO2} $	Breakover voltage symmetry	$C = 10\text{ nF}^{(2)}$	Max.	2	V
ΔV	Dynamic breakover voltage ⁽¹⁾	V_{BO} and V_F at 10 mA	Min.	9	V
V_O	Output voltage ⁽¹⁾	See Figure 2. Test circuit , ($R = 20\ \Omega$)	Min.	5	V
I_{BO}	Breakover current ⁽¹⁾	$C = 10\text{ nF}^{(2)}$	Max.	15	μA
t_r	Rise time ⁽¹⁾	See Figure 3. Rise time measurement	Max.	2	μs
I_R	Leakage current ⁽¹⁾	$V_R = 0.5 \times V_{BO}\text{ max}$	Max.	10	μA
I_P	Peak current ⁽¹⁾	See Figure 2. Test circuit	Min.	0.30	A

1. Applicable to both forward and reverse directions.
2. Connected in parallel to the device

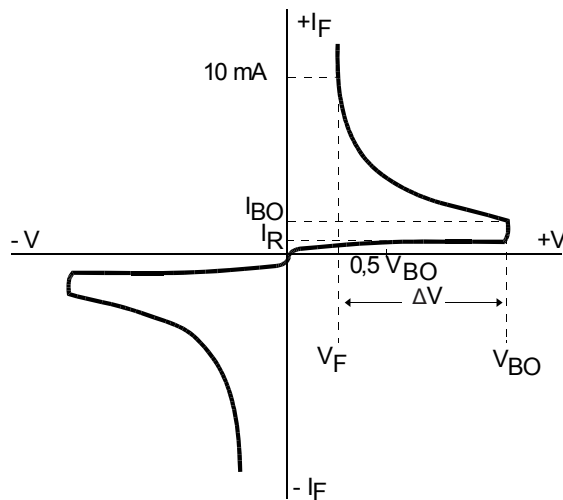
Figure 1. Voltage - current characteristic curve.


Figure 2. Test circuit

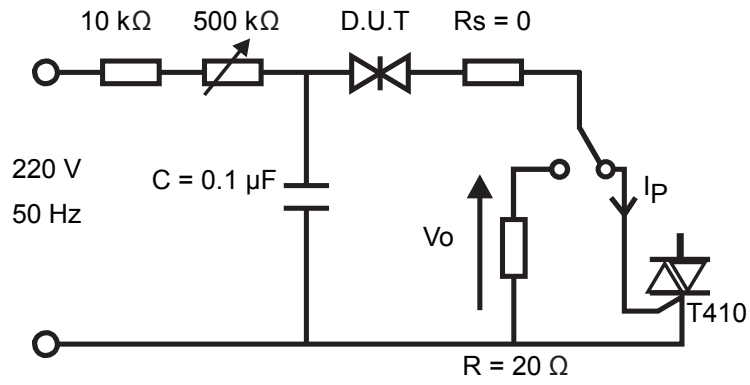
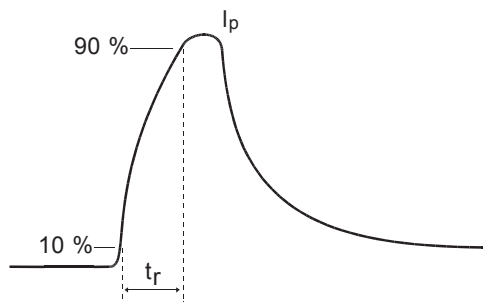


Figure 3. Rise time measurement



1.1 Characteristics (curves)

Figure 4. Relative variation of V_{BO} versus junction temperature (typical values)

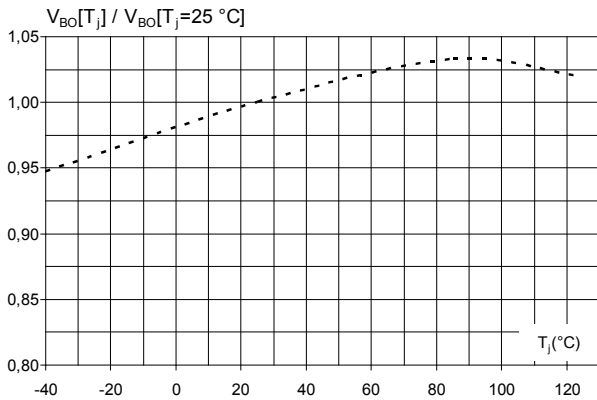


Figure 5. Peak on-state current versus Triac gate current pulse duration t_p

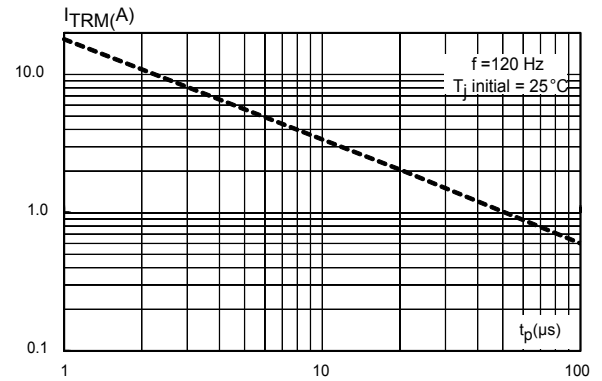
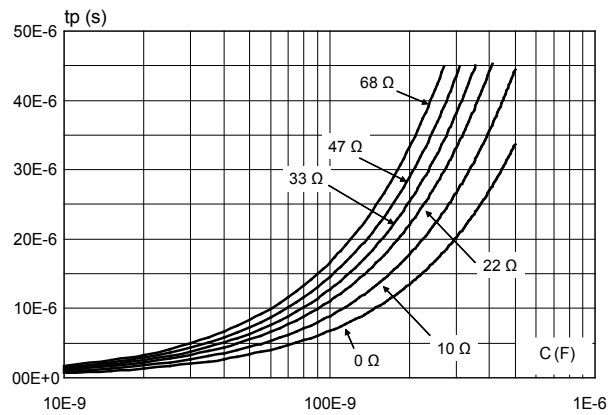


Figure 6. Triac gate current pulse duration t_p (to have $I_p > 50\text{ mA}$) versus R_s and C values (typical values)



Note: according to Figure 2. Test circuit

2 Package information

In order to meet environmental requirements, ST offers these devices in different grades of **ECOPACK** packages, depending on their level of environmental compliance. ECOPACK specifications, grade definitions and product status are available at: www.st.com. ECOPACK is an ST trademark.

2.1 Minimelf package information

Figure 7. MINIMELF package outline

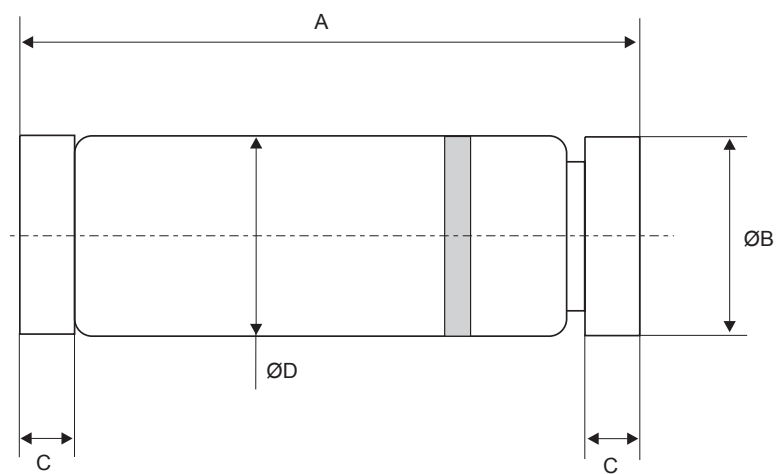
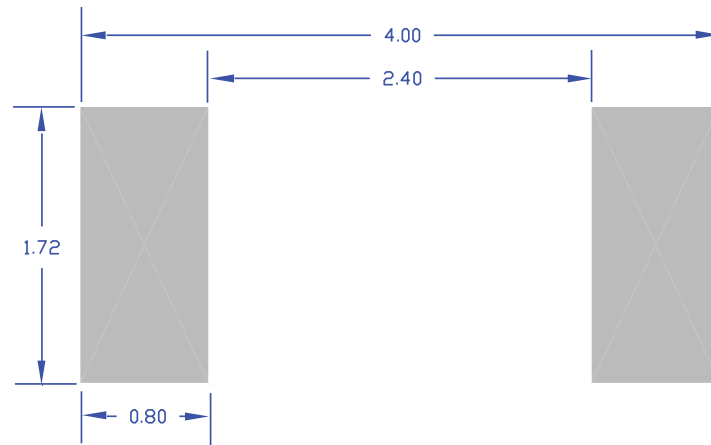


Table 3. MINIMELF package mechanical data

Dim.	mm					
	Min.	Typ.	Max.	Min.	Typ.	Max.
A	3.30	3.50	3.70	0.130	0.138	0.146
B	1.59	1.65	1.70	0.063	0.065	0.067
C	0.40	0.50	0.60	0.016	0.020	0.024
D		1.50			0.059	

Figure 8. MINIMELF recommended footprint (dimensions are in mm)



3 Ordering information

Figure 9. Ordering information scheme

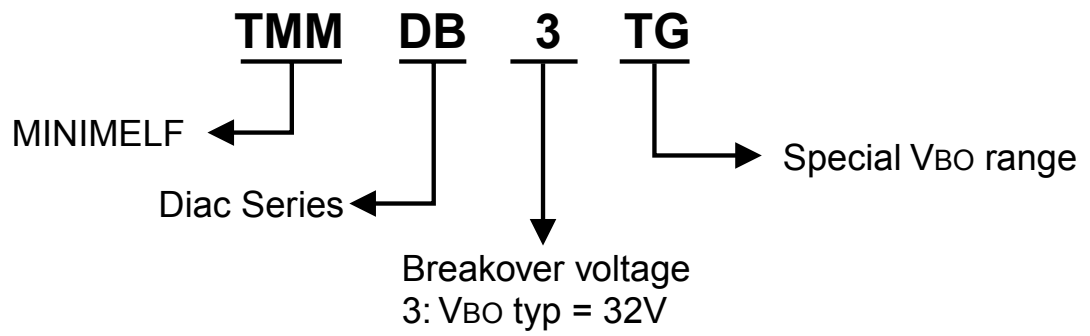


Table 4. Ordering information

Order code	Marking	Package	Weight	Base qty.	Delivery mode
TMMDB3TG	(None)	Minimelf	0.04 g	2500	Tape and reel

Revision history

Table 5. Document revision history

Date	Version	Changes
January-2001	2	Previous release.
07-May-2019	3	Updated Section 1.1 Characteristics (curves) and Table 3. MINIMELF package mechanical data . Minor text change to improve readability.

IMPORTANT NOTICE – PLEASE READ CAREFULLY

STMicroelectronics NV and its subsidiaries (“ST”) reserve the right to make changes, corrections, enhancements, modifications, and improvements to ST products and/or to this document at any time without notice. Purchasers should obtain the latest relevant information on ST products before placing orders. ST products are sold pursuant to ST’s terms and conditions of sale in place at the time of order acknowledgement.

Purchasers are solely responsible for the choice, selection, and use of ST products and ST assumes no liability for application assistance or the design of Purchasers’ products.

No license, express or implied, to any intellectual property right is granted by ST herein.

Resale of ST products with provisions different from the information set forth herein shall void any warranty granted by ST for such product.

ST and the ST logo are trademarks of ST. For additional information about ST trademarks, please refer to www.st.com/trademarks. All other product or service names are the property of their respective owners.

Information in this document supersedes and replaces information previously supplied in any prior versions of this document.

© 2019 STMicroelectronics – All rights reserved

Looking for pricing, stock, or lifecycle information?

Click below to explore more details on WIN SOURCE:

- ⊖ [View TMMDB3TG](#) on WIN SOURCE
- ⊖ [STMicroelectronics](#) Information

Optimize Your Supply Chain with WIN SOURCE Solutions

- ✓ Global Sourcing Solution
- ✓ Obsolete Management
- ✓ Cost Control Management
- ✓ Shortage Management
- ✓ Alternative Solution
- ✓ Excess Inventory Management