



**THE DATASHEET OF
TMP431ADGKR**



TMP43x $\pm 1^\circ\text{C}$ Temperature Sensor With Series-R, η -Factor, and Automatic Beta Compensation

1 Features

- $\pm 1^\circ\text{C}$ Remote Diode Sensor
- $\pm 1^\circ\text{C}$ Local Temperature Sensor
- Automatic Beta Compensation
- η -Factor Correction
- Programmable Threshold Limits
- Two-Wire, SMBus™ Serial Interface
- Minimum and Maximum Temperature Monitors
- Multiple Interface Addresses
- $\overline{\text{ALERT}}/\overline{\text{THERM2}}$ Pin Configuration
- Diode Fault Detection

2 Applications

- LCD, DLP®, LCOS Projectors
- Servers
- Industrial Controllers
- Central Office Telecom Equipment
- Desktop and Notebook Computers
- Storage Area Networks (SAN)
- Industrial And Medical Equipment
- Processor and FPGA Temperature Monitoring

3 Description

The TMP431 and TMP432 are remote temperature sensor monitors with a built-in local temperature sensor. The remote temperature sensor diode-connected transistors are typically low-cost, NPN- or PNP-type transistors or diodes that are an integral part of microcontrollers, microprocessors, or FPGAs.

Remote accuracy is $\pm 1^\circ\text{C}$ for multiple device manufacturers, with no calibration needed. The Two-Wire serial interface accepts SMBus write byte, read byte, send byte, and receive byte commands to program the alarm thresholds and to read temperature data.

The TMP43x include beta compensation (correction), series resistance cancellation, programmable non-ideality factor, programmable resolution, programmable threshold limits, minimum and maximum temperature monitors, wide remote temperature measurement range (up to 150°C), and diode fault detection and temperature alert function.

The TMP431 is available in a VSSOP-8 package and the TMP432 is available in a VSSOP-10 package.

Device Information⁽¹⁾

PART NUMBER	PACKAGE	BODY SIZE (NOM)
TMP431	VSSOP (8)	3.00 mm x 3.00 mm
TMP432	VSSOP (10)	3.00 mm x 3.00 mm

(1) For all available packages, see the orderable addendum at the end of the data sheet.

Typical Application Schematics

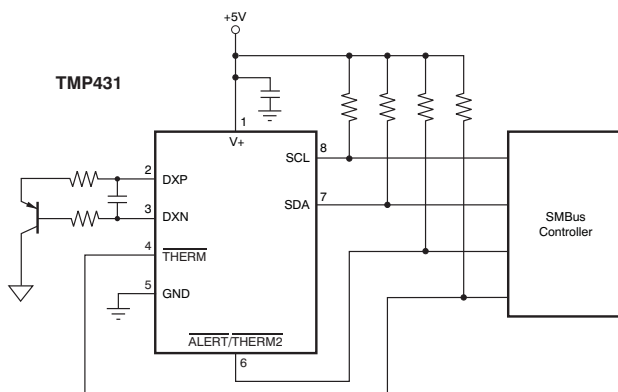

One Channel Local
One Channel Remote

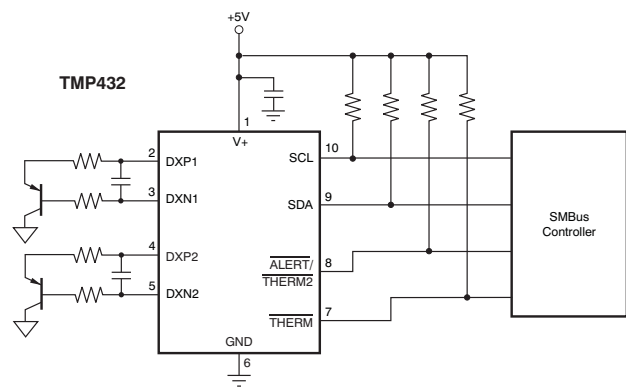

One Channel Local
Two Channels Remote



Changes from Revision B (April 2010) to Revision C **Page**

- Revised [Figure 14](#) 16
- Updated [Figure 15](#) 17
- Changed [Figure 16](#) 18
- Revised [Figure 17](#) 18
- Updated [Serial Bus Address](#) section for TMP431C, TMP431D device versions 19
- Added footnote (3) to [TMP431 Register Map](#) 21
- Revised information about power-on reset value of THERM limit registers in [Limit Registers](#) section 24

Changes from Revision A (November 2009) to Revision B **Page**

- Corrected [Equation 7](#) 33

Changes from Original (September 2009) to Revision A **Page**

- Changed device status for TMP432 throughout document 1
- Corrected bit D6 value in Configuration Register 1 in TMP431 Register Map 21

5 Pin Configuration and Functions

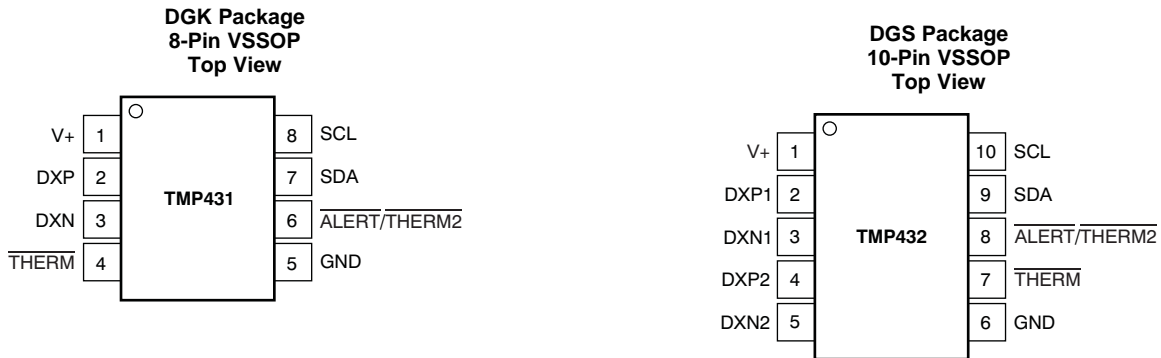

Pin Functions

NAME	PIN		I/O	DESCRIPTION
	TMP432	TMP431		
ALERT/THERM2	8	6	O	Digital alert (reconfigurable as second thermal flag), active low, open-drain; requires pullup resistor to V+
DXN	—	3	I	Analog negative connection to remote temperature sensor
DXN1	3	—	I	Analog channel 1 negative connection to remote temperature sensor
DXN2	5	—	I	Analog channel 2 negative connection to remote temperature sensor
DXP	—	2	I	Analog positive connection to remote temperature sensor
DXP1	2	—	I	Analog channel 1 positive connection to remote temperature sensor
DXP2	4	—	I	Analog channel 2 positive connection to remote temperature sensor
GND	6	5	—	Ground
SCL	10	8	I	Digital serial clock line for SMBus, open-drain; requires pullup resistor to V+
SDA	9	7	I/O	Bidirectional digital, serial data line for SMBus, open-drain; requires pullup resistor to V+
THERM	7	4	O	Digital, thermal flag, active low, open-drain; requires pullup resistor to V+
V+	1	1	—	Power supply, positive (2.7 V to 5.5 V)

6 Specifications

6.1 Absolute Maximum Ratings

over operating free-air temperature range (unless otherwise noted)⁽¹⁾

	MIN	MAX	UNIT	
Power supply, V _S		7	V	
TMP431 input voltage	Pins 2, 3, and 6	-0.5	V+ + 0.5	V
	Pins 4, 7, and 8	-0.5	7	V
TMP432 input voltage	Pins 2, 3, 4, 5, and 8	-0.5	V+ + 0.5	V
	Pins 7, 9, and 10	-0.5	7	V
Input current		10	mA	
Operating temperature	-55	127	°C	
Junction temperature, T _J		150	°C	
Storage temperature, T _{stg}	-60	130	°C	

(1) Stresses beyond those listed under *Absolute Maximum Ratings* may cause permanent damage to the device. These are stress ratings only, which do not imply functional operation of the device at these or any other conditions beyond those indicated under *Recommended Operating Conditions*. Exposure to absolute-maximum-rated conditions for extended periods may affect device reliability.

6.2 ESD Ratings

		VALUE	UNIT
V _(ESD)	Electrostatic discharge		
	Human-body model (HBM), per ANSI/ESDA/JEDEC JS-001 ⁽¹⁾	±4000	V
	Charged-device model (CDM), per JEDEC specification JESD22-C101 ⁽²⁾	±1000	
Machine model (MM)	±200		

(1) JEDEC document JEP155 states that 500-V HBM allows safe manufacturing with a standard ESD control process.

(2) JEDEC document JEP157 states that 250-V CDM allows safe manufacturing with a standard ESD control process.

6.3 Recommended Operating Conditions

over operating free-air temperature range (unless otherwise noted)

	MIN	NOM	MAX	UNIT
Supply voltage	2.7	3.3	5.5	V
Operating free-air temperature, T _A	–40		125	°C

6.4 Thermal Information

THERMAL METRIC ⁽¹⁾		TMP431	TMP432	UNIT
		DGK (VSSOP)	DGS (VSSOP)	
		8 PINS	10 PINS	
R _{θJA}	Junction-to-ambient thermal resistance	168.2	164.6	°C/W
R _{θJC(top)}	Junction-to-case (top) thermal resistance	59.7	39	°C/W
R _{θJB}	Junction-to-board thermal resistance	90.1	85.9	°C/W
Ψ _{JT}	Junction-to-top characterization parameter	7.7	1.6	°C/W
Ψ _{JB}	Junction-to-board characterization parameter	88.4	84.2	°C/W
R _{θJC(bot)}	Junction-to-case (bottom) thermal resistance	N/A	N/A	°C/W

(1) For more information about traditional and new thermal metrics, see the *Semiconductor and IC Package Thermal Metrics* application report, [SPRA953](#).

6.5 Electrical Characteristics

 at $T_A = -40^\circ\text{C}$ to 125°C and $V_+ = 2.7\text{ V}$ to 5.5 V (unless otherwise noted)

PARAMETER		TEST CONDITIONS	MIN	TYP	MAX	UNIT
TEMPERATURE ERROR						
$T_{E_{LOCAL}}$	Local temperature sensor	$T_A = -40^\circ\text{C}$ to 125°C		± 1.25	± 2.5	$^\circ\text{C}$
		$T_A = 0^\circ\text{C}$ to 100°C , $V_+ = 3.3\text{ V}$		± 0.25	± 1	
$T_{E_{REMOTE}}$	Remote temperature sensor ⁽¹⁾	$T_A = 0^\circ\text{C}$ to 100°C , $T_{DIODE} = -40^\circ\text{C}$ to 150°C , $V_+ = 3.3\text{ V}$		± 0.25	± 1	$^\circ\text{C}$
		$T_A = -40^\circ\text{C}$ to 100°C , $T_{DIODE} = -40^\circ\text{C}$ to 150°C , $V_+ = 3.3\text{ V}$		± 0.5	± 1.5	
		$T_A = -40^\circ\text{C}$ to 125°C , $T_{DIODE} = -40^\circ\text{C}$ to 150°C		± 3	± 5	
vs supply (local, remote)		$V_+ = 2.7\text{ V}$ to 5.5 V		± 0.2	± 0.5	$^\circ\text{C/V}$
TEMPERATURE MEASUREMENT CONVERSION TIME (PER CHANNEL)						
Local channel			12	15	17	ms
	Remote channel, beta correction enabled ⁽²⁾	RC = 1	97	126	137	ms
		RC = 0	36	47	52	
	Remote channel, beta correction disabled ⁽²⁾	RC = 1	72	93	100	ms
		RC = 0	33	44	47	
TEMPERATURE MEASUREMENT RESOLUTION						
Local channel				12		Bits
Remote channel				12		Bits
TEMPERATURE MEASUREMENT REMOTE SENSOR SOURCE CURRENTS						
	High	Series resistance (beta correction) ⁽⁴⁾		120		μA
	Medium-high			60		μA
	Medium-low			12		μA
	Low			6		μA
η	Remote transistor ideality factor	TMP43x optimized ideality factor		1.000 ⁽²⁾		
				1.008 ⁽³⁾		
β	Beta correction range		0.1		27	
SMBus INTERFACE						
V_{IH}	Logic input high voltage (SCL, SDA)		2.1			V
V_{IL}	Logic input low voltage (SCL, SDA)				0.8	V
	Hysteresis			500		mV
	SMBus output low sink current		6			mA
V_{OL}	SDA output low voltage	$I_{OUT} = 6\text{ mA}$		0.15	0.4	V
	Logic input current	$0 \leq V_{IN} \leq 6\text{ V}$	-1		1	μA
	SMBus input capacitance (SCL, SDA)			3		pF
	SMBus clock frequency				3.4	MHz
	SMBus timeout		25	32	35	ms
	SCL falling edge to SDA valid time				1	μs
DIGITAL OUTPUTS						
V_{OL}	Output low voltage	$I_{OUT} = 6\text{ mA}$		0.15	0.4	V
I_{OH}	High-level output leakage current	$V_{OUT} = V_+$		0.1	1	μA
	$\overline{\text{ALERT}}/\overline{\text{THERM2}}$ output low sink current	$\overline{\text{ALERT}}/\overline{\text{THERM2}}$ forced to 0.4 V	6			mA
	$\overline{\text{THERM}}$ output low sink current	$\overline{\text{THERM2}}$ forced to 0.4 V	6			mA

- (1) Tested with less than 5- Ω effective series resistance and 100-pF differential input capacitance. T_A is the ambient temperature of the TMP43x. T_{DIODE} is the temperature at the remote diode sensor.
- (2) Beta correction configuration set to 1000 and sensor is GND collector-connected (PNP collector to ground).
- (3) Beta correction configuration set to 0111 or sensor is diode-connected (base shorted to collector).
- (4) If beta correction is disabled (0111), then up to 1-k Ω of series line resistance is cancelled; if beta correction is enabled (1xxx), up to 300 Ω is cancelled.

Electrical Characteristics (continued)

 at $T_A = -40^{\circ}\text{C}$ to 125°C and $V_+ = 2.7\text{ V}$ to 5.5 V (unless otherwise noted)

PARAMETER		TEST CONDITIONS	MIN	TYP	MAX	UNIT	
POWER SUPPLY							
V_+	Specified voltage range		2.7		5.5	V	
I_Q	Quiescent current	0.0625 conversions per second, $V_+ = 3.3\text{ V}$		35	45	μA	
		Eight conversions per second, $V_+ = 3.3\text{ V}$ ⁽⁵⁾		0.7	1	mA	
		Serial bus inactive, shutdown mode			3	10	μA
		Serial bus active, $f_S = 400\text{ kHz}$, shutdown mode			90		
		Serial bus active, $f_S = 3.4\text{ MHz}$, shutdown mode			350		
UVLO	Undervoltage lockout		2.3	2.4	2.6	V	
POR	Power-on reset threshold			1.6	2.3	V	
	Specified temperature range		-40		125	$^{\circ}\text{C}$	
	Storage temperature range		-60		130	$^{\circ}\text{C}$	

(5) Beta correction disabled.

6.6 Timing Requirements⁽¹⁾

			FAST MODE		HIGH-SPEED MODE		UNIT
			MIN	MAX	MIN	MAX	
$f_{(SCL)}$	SCL operating frequency	V_+	0.001	0.4	0.001	2.5	MHz
$t_{(BUF)}$	Bus free time between STOP and START condition		600		160		ns
$t_{(HDSTA)}$	Hold time after repeated START condition. After this period, the first clock is generated.		100		100		ns
$t_{(SUSTA)}$	Repeated START condition setup time		100		100		ns
$t_{(SUSTO)}$	STOP condition setup time		100		100		ns
$t_{(HDDAT)}$	Data hold time		0 ⁽²⁾	900	0 ⁽³⁾	80	ns
$t_{(SUDAT)}$	Data setup time		100		25		ns
$t_{(LOW)}$	SCL clock LOW period	V_+	1300		265		ns
$t_{(HIGH)}$	SCL clock HIGH period		600		60		ns
t_{FD}	Data fall time		300		160		ns
t_{RC}	Clock rise time		300		40		ns
		SCLK $\leq 100\text{ kHz}$	1000				
t_{FC}	Clock fall time		300		40		ns

- (1) Values based on a statistical analysis of a one-time sample of devices. Minimum and maximum values are not specified and not production tested.
- (2) For cases with a fall time of SCL less than 20 ns or where the rise time or fall time of SDA is less than 20 ns, the hold time must be greater than 20 ns.
- (3) For cases with a fall time of SCL less than 10 ns or where the rise or fall time of SDA is less than 10 ns, the hold time must be greater than 10 ns.

6.7 Typical Characteristics

At $T_A = 25^\circ\text{C}$ and $V_+ = 3.3\text{ V}$, unless otherwise noted.

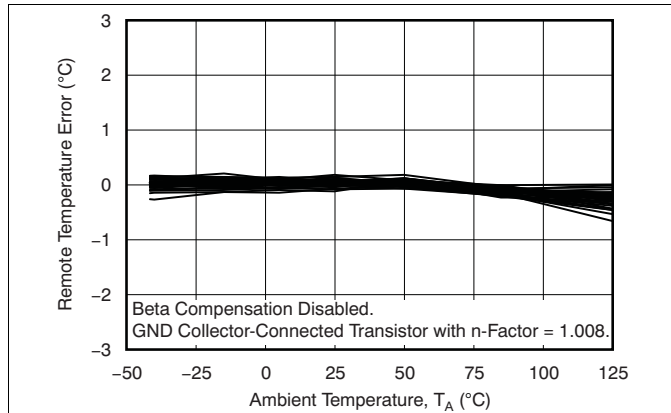

Figure 1. Remote Temperature Error vs Temperature

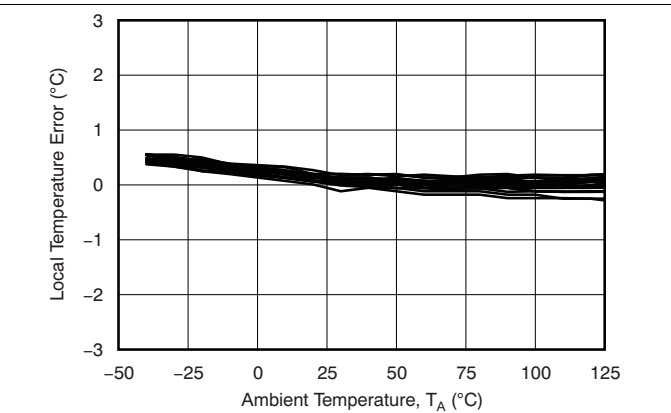

Figure 2. Local Temperature Error vs Temperature

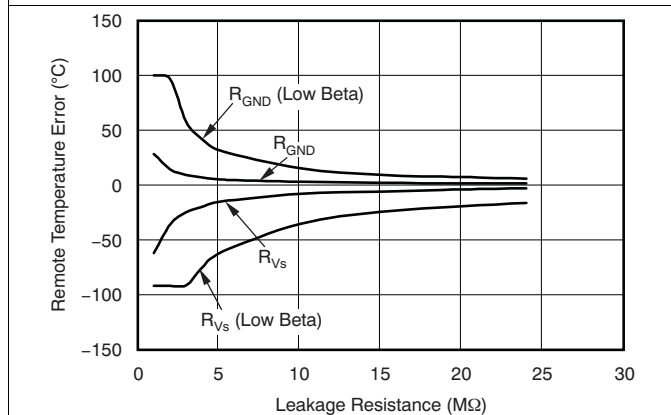

Figure 3. Remote Temperature Error vs Leakage Resistance

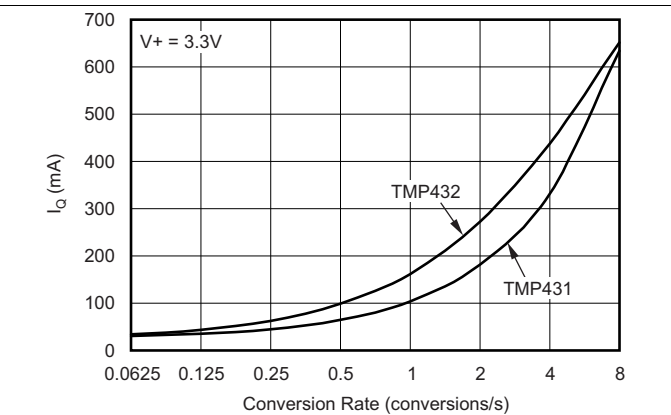

Figure 4. Quiescent Current vs Conversion Rate

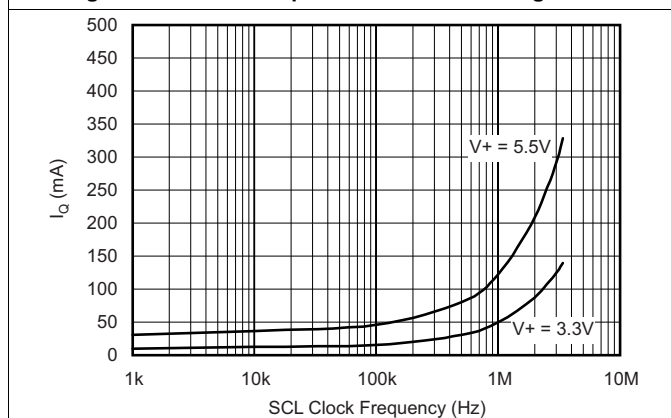

Figure 5. Shutdown Quiescent Current vs SCL Clock Frequency

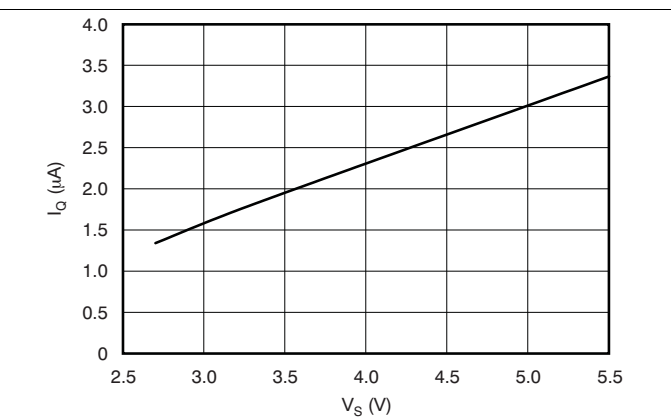

Figure 6. Shutdown Quiescent Current vs Supply Voltage

Typical Characteristics (continued)

At $T_A = 25^\circ\text{C}$ and $V_+ = 3.3\text{ V}$, unless otherwise noted.

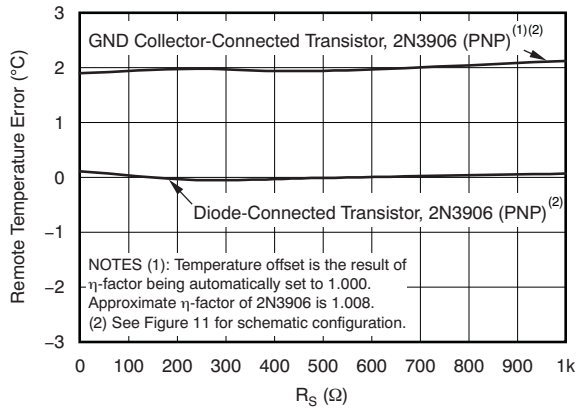

Figure 7. Remote Temperature Error vs Series Resistance

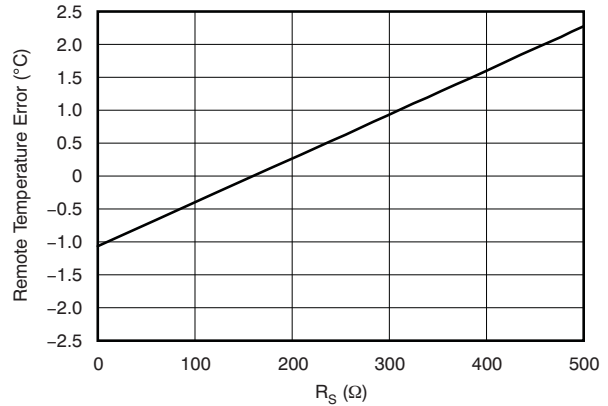
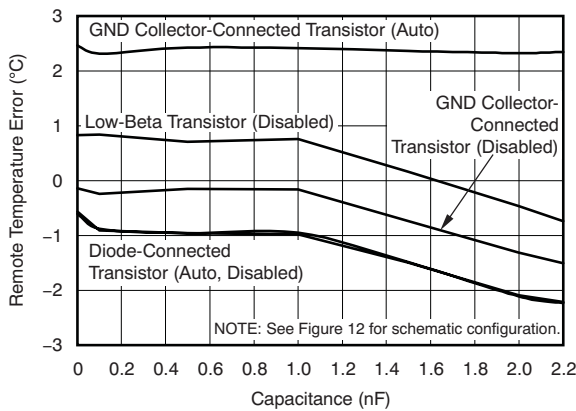
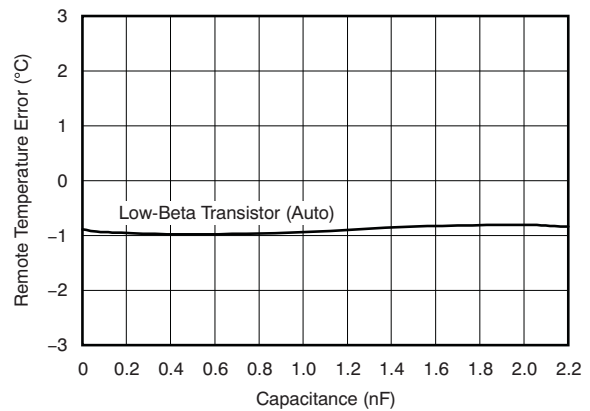

Figure 8. Remote Temperature Error vs Series Resistance (Low-Beta Transistor)



At 25°C , $V_+ = 3.3\text{ V}$, $R_S = 0\ \Omega$

Figure 9. Remote Temperature Error vs Differential Capacitance



At 25°C , $V_+ = 3.3\text{ V}$, $R_S = 0\ \Omega$, Beta = 011 (AUTO)

Figure 10. Remote Temperature Error vs Differential Capacitance With 45-nm CPU

7 Parametric Measurement Information

(a) GND Collector-Connected Transistor

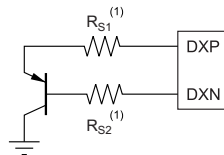

(b) Diode-Connected Transistor

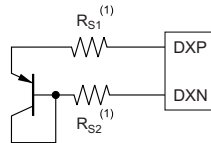

- (1) The total series resistance $R_S = R_{S1} + R_{S2}$ must be less than 1 k Ω ; see [Filtering](#).

Figure 11. Series Resistance Configuration

(a) GND Collector-Connected Transistor

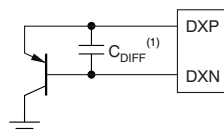

(b) Diode-Connected Transistor

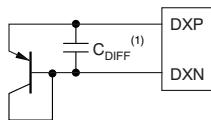

- (1) C_{DIFF} must be less than 2200 pF; see [Filtering](#).

Figure 12. Differential Capacitance Configuration

8 Detailed Description

8.1 Overview

The TMP431 (two-channel) and TMP432 (three-channel) are digital temperature sensors that combine a local die temperature measurement channel and a remote junction temperature measurement channel in a single VSSOP-8 (TMP431) or VSSOP-10 (TMP432) package. They are Two-Wire- and SMBus interface-compatible and are specified over a temperature range of -40°C to 125°C . The TMP43x contain multiple registers for holding configuration information, temperature measurement results, temperature comparator maximum and minimum limits, and status information. User-programmed high and low temperature limits stored in the TMP43x can be used to trigger an overtemperature and undertemperature alarm ($\overline{\text{ALERT}}$) on local and remote temperatures. Additional thermal limits can be programmed into the TMP43x and used to trigger another flag ($\overline{\text{THERM}}$) that can be used to initiate a system response to rising temperatures.

For proper remote temperature sensing operation, the TMP431 requires only a transistor connected between DXP and DXN; the TMP432 requires transistors connected between DXP1 and DXN1, and between DXP2 and DXN2.

The SCL and SDA interface pins require pullup resistors as part of the communication bus; $\overline{\text{ALERT}}$ and $\overline{\text{THERM}}$ are open-drain outputs that also need pullup resistors. $\overline{\text{ALERT}}$ and $\overline{\text{THERM}}$ can be shared with other devices if desired for a wired-OR implementation. TI recommends a 0.1- μF power-supply bypass capacitor for good local bypassing.

8.2 Functional Block Diagram

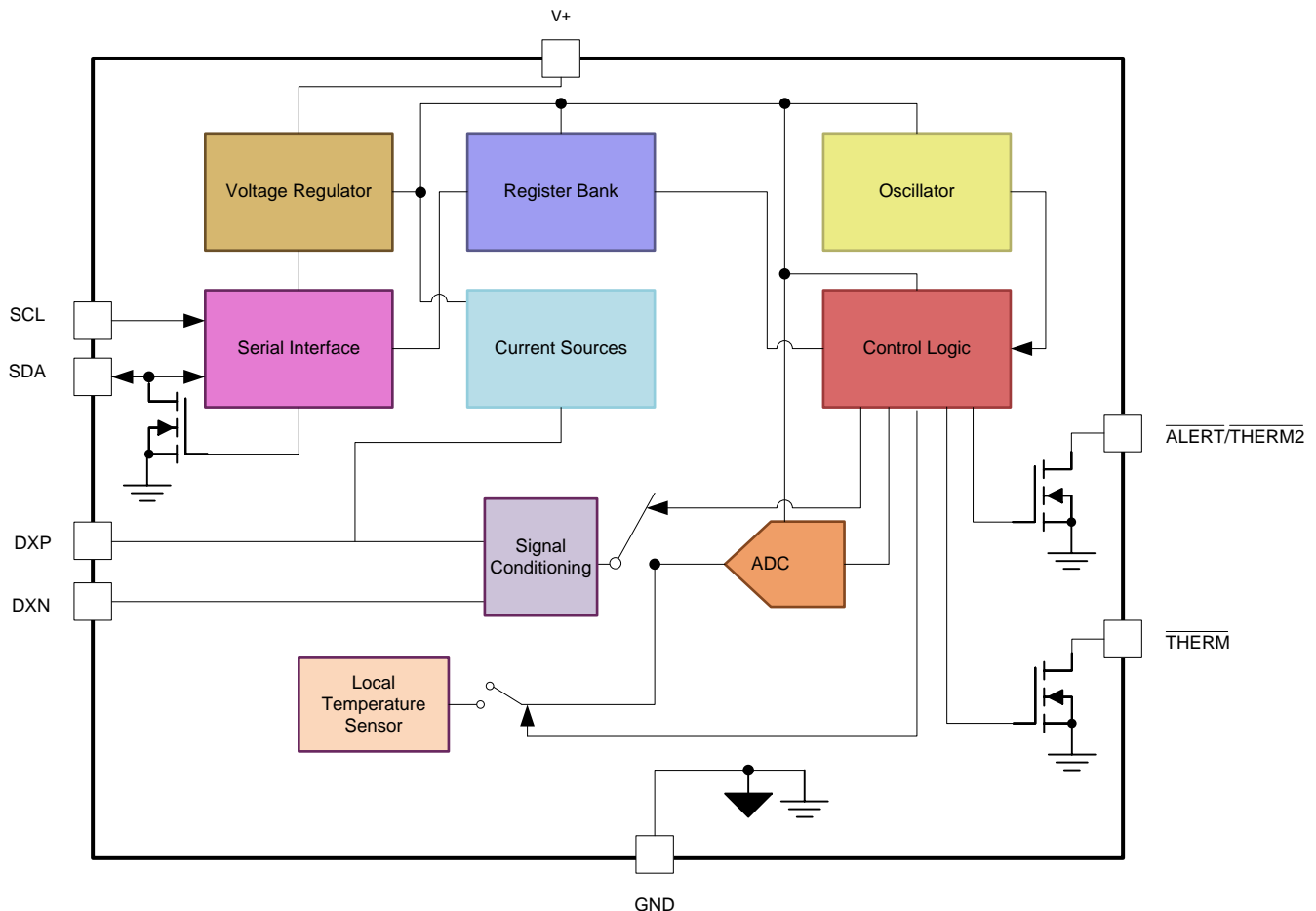

8.3 Feature Description

8.3.1 Temperature Measurement Data

Temperature measurement data are taken over a default range of 0°C to 127°C for both local and remote locations. However, measurements from –55°C to 150°C can be made both locally and remotely by reconfiguring the TMP43x for the extended temperature range, as described in this section. Temperature data resulting from conversions within the default measurement range are represented in binary form, as shown in [Table 1](#), *Standard Binary* column. Note that any temperature below 0°C results in a data value of zero (00h). Likewise, temperatures above 127°C result in a value of 127 (7Fh). The device can be set to measure over an extended temperature range by changing bit 2 of Configuration Register 1 from low to high. The change in measurement range and data format from standard binary to extended binary occurs at the next temperature conversion.

For data captured in the extended temperature range configuration, an offset of 64 (40h) is added to the standard binary value, as shown in [Table 1](#), *Extended Binary* column. This configuration allows measurement of temperatures as low as –64°C, and as high as 191°C; however, most temperature-sensing diodes only measure with the range of –55°C to 150°C.

Additionally, the TMP43x are rated only for ambient local temperatures ranging from –40°C to 125°C. Parameters in [Absolute Maximum Ratings](#) must be observed.

Both local and remote temperature data use two bytes for data storage. The high byte stores the temperature with 1°C resolution. The second or low byte stores the decimal fraction value of the temperature and allows a higher measurement resolution; see [Table 2](#).

The measurement resolution for both the local and remote channels is 0.0625°C, and cannot be adjusted.

Table 1. Temperature Data Format (Local and Remote Temperature High Bytes)

TEMP (°C)	LOCAL/REMOTE TEMPERATURE REGISTER HIGH BYTE VALUE (1°C RESOLUTION)			
	STANDARD BINARY ⁽¹⁾		EXTENDED BINARY ⁽²⁾	
	BINARY	HEX	BINARY	HEX
–64	0000 0000	00	0000 0000	00
–50	0000 0000	00	0000 1110	0E
–25	0000 0000	00	0010 0111	27
0	0000 0000	00	0100 0000	40
1	0000 0001	01	0100 0001	41
5	0000 0101	05	0100 0101	45
10	0000 1010	0A	0100 1010	4A
25	0001 1001	19	0101 1001	59
50	0011 0010	32	0111 0010	72
75	0100 1011	4B	1000 1011	8B
100	0110 0100	64	1010 0100	A4
125	0111 1101	7D	1011 1101	BD
127	0111 1111	7F	1011 1111	BF
150	0111 1111	7F	1101 0110	D6
175	0111 1111	7F	1110 1111	EF
191	0111 1111	7F	1111 1111	FF

(1) Resolution is 1°C per count. Negative numbers are represented in twos complement format.

(2) Resolution is 1°C per count. All values are unsigned with a –64°C offset.

Table 2. Decimal Fraction Temperature Data Format (Local and Remote Temperature Low Bytes)

TEMP (°C)	TEMPERATURE REGISTER LOW BYTE VALUE (0.0625°C RESOLUTION) ⁽¹⁾	
	STANDARD AND EXTENDED BINARY	HEX
0	0000 0000	00
0.0625	0001 0000	10
0.1250	0010 0000	20
0.1875	0011 0000	30
0.2500	0100 0000	40
0.3125	0101 0000	50
0.3750	0110 0000	60
0.4375	0111 0000	70
0.5000	1000 0000	80
0.5625	1001 0000	90
0.6250	1010 0000	A0
0.6875	1011 0000	B0
0.7500	1100 0000	C0
0.8125	1101 0000	D0
0.8750	1110 0000	E0
0.9375	1111 0000	F0

(1) Resolution is 0.0625°C per count. All possible values are shown.

8.3.2 Beta Compensation

Previous generations of remote junction temperature sensors were operated by controlling the emitter current of the sensing transistor. However, examination of the physics of a transistor shows that V_{BE} is actually a function of the collector current. If beta is independent of the collector current, then V_{BE} can be calculated from the emitter current. In earlier generations of processors that contained PNP transistors connected to these temperature sensors, controlling the emitter current provided acceptable temperature measurement results. At 90-nm process geometry and below, however, the beta factor continues to decrease and the premise that it is independent of collector current becomes less certain.

To manage this increasing temperature measurement error, the TMP43x control the collector current instead of the emitter current. The TMP43x automatically detect and choose the correct range depending on the beta factor of the external transistor. This auto-ranging is performed at the beginning of each temperature conversion in order to correct for any changes in the beta factor as a result of temperature variation. The device can operate a PNP transistor with a beta factor as low as 0.1. See [Beta Compensation Configuration Register](#) for further information.

8.3.3 Series Resistance Cancellation

Series resistance in an application circuit that typically results from printed circuit-board (PCB) trace resistance and remote line length is automatically cancelled by the TMP43x, preventing what would otherwise result in a temperature offset. A total of up to 1-k Ω of series line resistance is cancelled by the TMP43x if beta correction is disabled and up to 300 Ω of series line resistance is cancelled if beta correction is enabled, eliminating the need for additional characterization and temperature offset correction. See [Figure 7](#) and [Figure 8](#) for details on the effects of series resistance on sensed remote temperature error.

8.3.4 Differential Input Capacitance

The TMP43x can tolerate differential input capacitance of up to 2200 pF with minimal change in temperature error. The effect of capacitance on sensed remote temperature error is illustrated in [Figure 9](#) and [Figure 10](#). See [Filtering](#) for suggested component values where filtering unwanted coupled signals is needed.

8.3.5 Filtering

Remote junction temperature sensors are usually implemented in noisy environments. Noise is frequently generated by fast digital signals and if not filtered properly can induce errors that corrupt temperature measurements. The TMP43x have a built-in 65-kHz filter on the inputs of DXP and DXN to minimize the effects of noise. However, a differential low-pass filter can help attenuate unwanted coupled signals. Exact component values are application-specific. TI also recommends that the capacitor value remains from 0 pF to 2200 pF with a series resistance less than 1 k Ω .

8.3.6 Sensor Fault

The TMP43x can sense a fault at the DXP input that results from an incorrect diode connection or an open circuit. The detection circuitry consists of a voltage comparator that trips when the voltage at DXP exceeds $(V+) - 0.6\text{ V}$ (typical). The comparator output is continuously checked during a conversion. If a fault is detected, the last valid measured temperature is used for the temperature measurement result, the OPEN bit (Status Register, bit 2) is set high, and, if the alert function is enabled, $\overline{\text{ALERT}}$ asserts low.

When not using the remote sensor with the TMP43x, the DXP and DXN inputs must be connected together to prevent meaningless fault warnings.

8.3.7 $\overline{\text{THERM}}$ and $\overline{\text{ALERT/THERM2}}$

The TMP43x have two pins dedicated to alarm functions, the $\overline{\text{THERM}}$ and $\overline{\text{ALERT/THERM2}}$ pins. Both pins are open-drain outputs that each require a pullup resistor to $V+$. These pins can be wire-ORed together with other alarm pins for system monitoring of multiple sensors. The $\overline{\text{THERM}}$ pin provides a thermal interrupt that cannot be software disabled. The $\overline{\text{ALERT}}$ pin is intended for use as an earlier warning interrupt, and can be software disabled, or masked. The $\overline{\text{ALERT/THERM2}}$ pin can also be configured for use as $\overline{\text{THERM2}}$, a second $\overline{\text{THERM}}$ pin (Configuration Register 1: AL/TH bit = 1). The default setting configures pin 6 for the TMP431 and pin 8 for the TMP432 to function as $\overline{\text{ALERT}}$ (AL/TH = 0).

The $\overline{\text{THERM}}$ pin asserts low when either the measured local or remote temperature is outside of the temperature range programmed in the corresponding Local/Remote THERM Limit Register. The $\overline{\text{THERM}}$ temperature limit range can be programmed with a wider range than that of the limit registers, which allows $\overline{\text{ALERT}}$ to provide an earlier warning than $\overline{\text{THERM}}$. The $\overline{\text{THERM}}$ alarm resets automatically when the measured temperature returns to within the $\overline{\text{THERM}}$ temperature limit range minus the hysteresis value stored in the $\overline{\text{THERM}}$ Hysteresis Register. The allowable values of hysteresis are listed in Table 13. The default hysteresis is 10°C. When the $\overline{\text{ALERT/THERM2}}$ pin is configured as a second thermal alarm (Configuration Register: bit 7 = x, bit 5 = 1), it functions the same as $\overline{\text{THERM}}$, but uses the temperatures stored in the Local/Remote Temperature High Limit Registers to set its comparison range.

When $\overline{\text{ALERT/THERM2}}$ is configured as $\overline{\text{ALERT}}$ (Configuration Register 1: bit 7 = 0, bit 5 = 0), the pin asserts low when either the measured local or remote temperature violates the range limit set by the corresponding Local/Remote Temperature High/Low Limit Registers. This alert function can be configured to assert only if the range is violated a specified number of consecutive times (1, 2, 3, or 4). The consecutive violation limit is set in the Consecutive Alert Register. False alerts that occur as a result of environmental noise can be prevented by requiring consecutive faults. $\overline{\text{ALERT}}$ also asserts low if the remote temperature sensor is open-circuit. When the MASK function is enabled (Configuration Register 1: bit 7 = 1), $\overline{\text{ALERT}}$ is disabled (that is, masked). $\overline{\text{ALERT}}$ resets when the master reads the device address, as long as the condition that caused the alert no longer persists, and the Status Register has been reset.

8.4 Device Functional Modes

8.4.1 Shutdown Mode (SD)

The TMP43x shutdown mode allows the user to save maximum power by shutting down all device circuitry other than the serial interface, reducing current consumption to typically less than 3 μA ; see Figure 6. Shutdown mode is enabled when the SD bit of the Configuration Register 1 is high; the device shuts down immediately, aborting the current conversion. When SD is low, the device maintains a continuous conversion state.

Device Functional Modes (continued)

8.4.2 One-Shot Mode

When the TMP43x are in shutdown mode ($SD = 1$ in the Configuration Register 1), a single conversion on both channels is started by writing any value to the One-Shot Start Register, pointer address 0Fh. This write operation starts one conversion; the TMP43x return to shutdown mode when that conversion completes. The value of the data sent in the write command is irrelevant and is not stored by the TMP43x. When the TMP43x are in shutdown mode, an initial 200 ps is required before a one-shot command can be given. (Note: When a shutdown command is issued, the TMP43x shut down immediately, aborting the current conversion.) This wait time only applies to the 200 ps immediately following shutdown. One-shot commands can be issued without delay thereafter.

8.5 Programming

8.5.1 Serial Interface

The TMP43x operate only as slave devices on either the Two-Wire bus or the SMBus. Connections to either bus are made via the open-drain I/O lines, SDA and SCL. The SDA and SCL pins feature integrated spike suppression filters and Schmitt triggers to minimize the effects of input spikes and bus noise. The TMP43x support the transmission protocol for fast (1 kHz to 400 kHz) and high-speed (1 kHz to 2.5 MHz) modes. All data bytes are transmitted MSB first.

8.5.2 Bus Overview

The TMP43x are SMBus interface-compatible. In SMBus protocol, the device that initiates the transfer is called a *master*, and the devices controlled by the master are *slaves*. The bus must be controlled by a master device that generates the serial clock (SCL), controls the bus access, and generates the START and STOP conditions.

To address a specific device, a START condition is initiated. START is indicated by pulling the data line (SDA) from a high to low logic level when SCL is high. All slaves on the bus shift in the slave address byte, with the last bit indicating whether a read or write operation is intended. During the ninth clock pulse, the slave being addressed responds to the master by generating an Acknowledge and pulling SDA low.

Data transfer is then initiated and sent over eight clock pulses followed by an Acknowledge bit. During data transfer SDA must remain stable when SCL is high because any change in SDA when SCL is high is interpreted as a control signal.

When all data are transferred, the master generates a STOP condition. STOP is indicated by pulling SDA from low to high when SCL is high.

8.5.3 Timing Diagrams

The TMP43x are Two-Wire and SMBus-compatible. [Figure 13](#) to [Figure 17](#) describe the various operations on the TMP43x. Parameters for [Figure 13](#) are defined in [Figure 14](#). Bus definitions are given below:

Bus Idle: Both SDA and SCL lines remain high.

Start Data Transfer: A change in the state of the SDA line from high to low when the SCL line is high defines a START condition. Each data transfer is initiated with a START condition.

Stop Data Transfer: A change in the state of the SDA line from low to high when the SCL line is high defines a STOP condition. Each data transfer terminates with a STOP or a repeated START condition.

Data Transfer: The number of data bytes transferred between a START and a STOP condition is not limited and is determined by the master device. The receiver acknowledges the transfer of data.

Acknowledge: Each receiving device, when addressed, is obliged to generate an Acknowledge bit. A device that acknowledges must pull down the SDA line during the Acknowledge clock pulse in such a way that the SDA line is stable low during the high period of the Acknowledge clock pulse. Setup and hold times must be taken into account. On a master receive, data transfer termination can be signaled by the master generating a Not-Acknowledge on the last byte that has been transmitted by the slave.

Programming (continued)

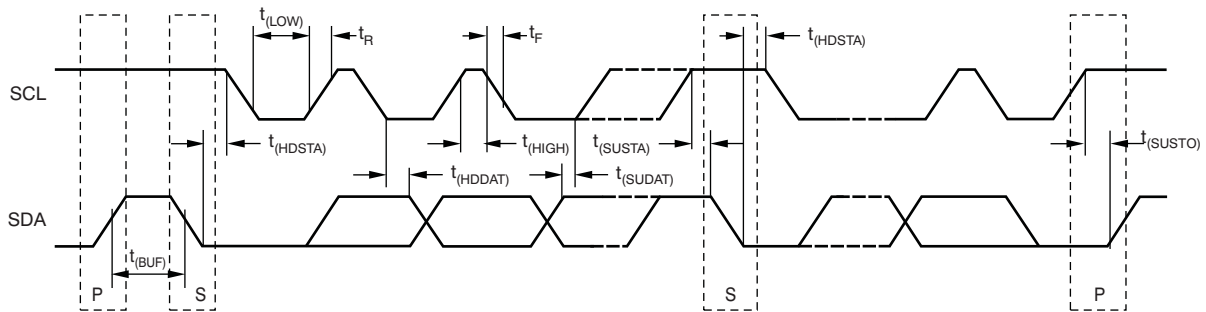
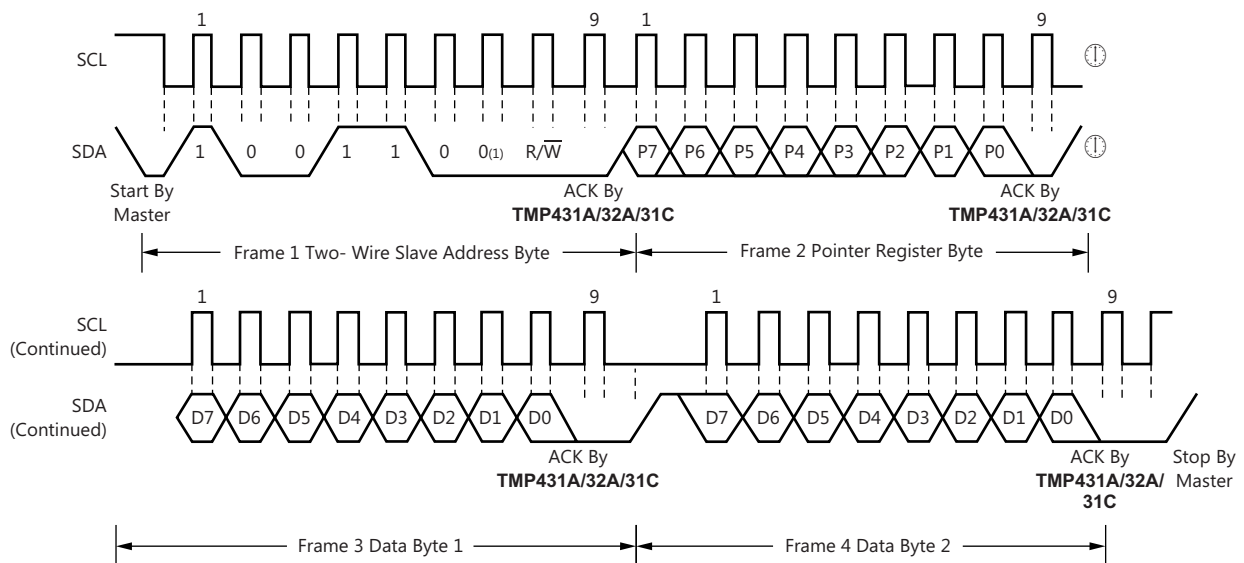

Figure 13. Two-Wire Timing Diagram



(1) Slave address 1001100 (TMP431A, 32A, and 31C) shown. Slave address changes for TMP431B, 32B, and 31D. See [Mechanical, Packaging, and Orderable Information](#) for more details.

Figure 14. Two-Wire Timing Diagram for Write Word Format

Programming (continued)

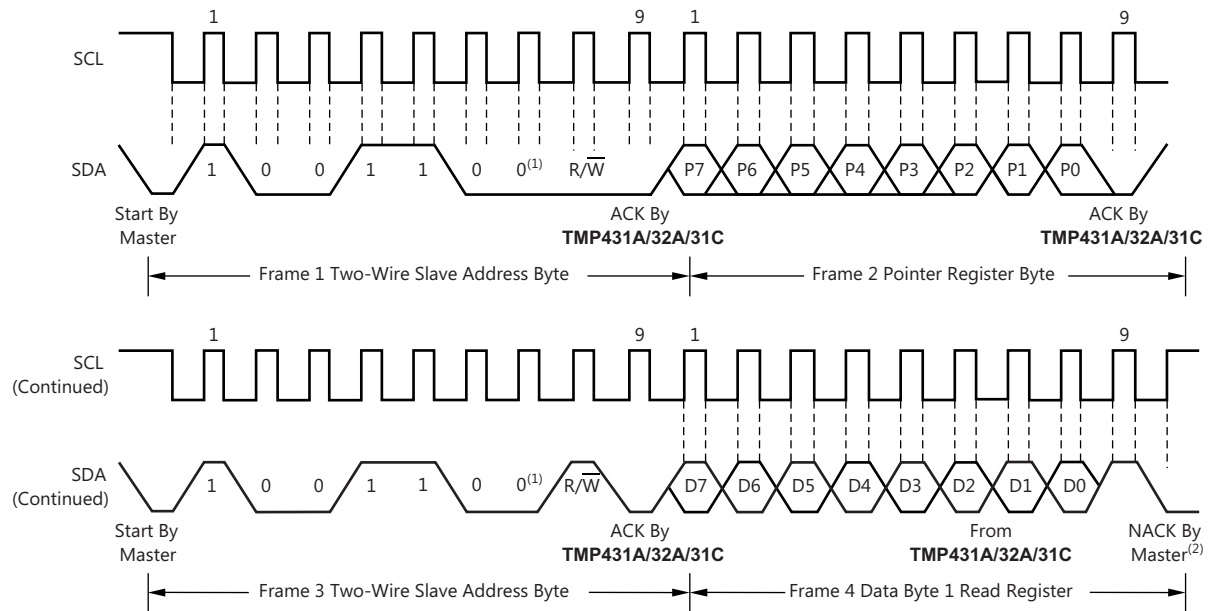

- (1) Slave address 1001100 (TMP431A, 32A, and 31C) shown. Slave address changes for TMP431B, 32B, and 31D. See [Mechanical, Packaging, and Orderable Information](#) for more details.
- (2) Master must leave SDA high to terminate a single-byte read operation.

Figure 15. Two-Wire Timing Diagram for Single-Byte Read Format

Programming (continued)

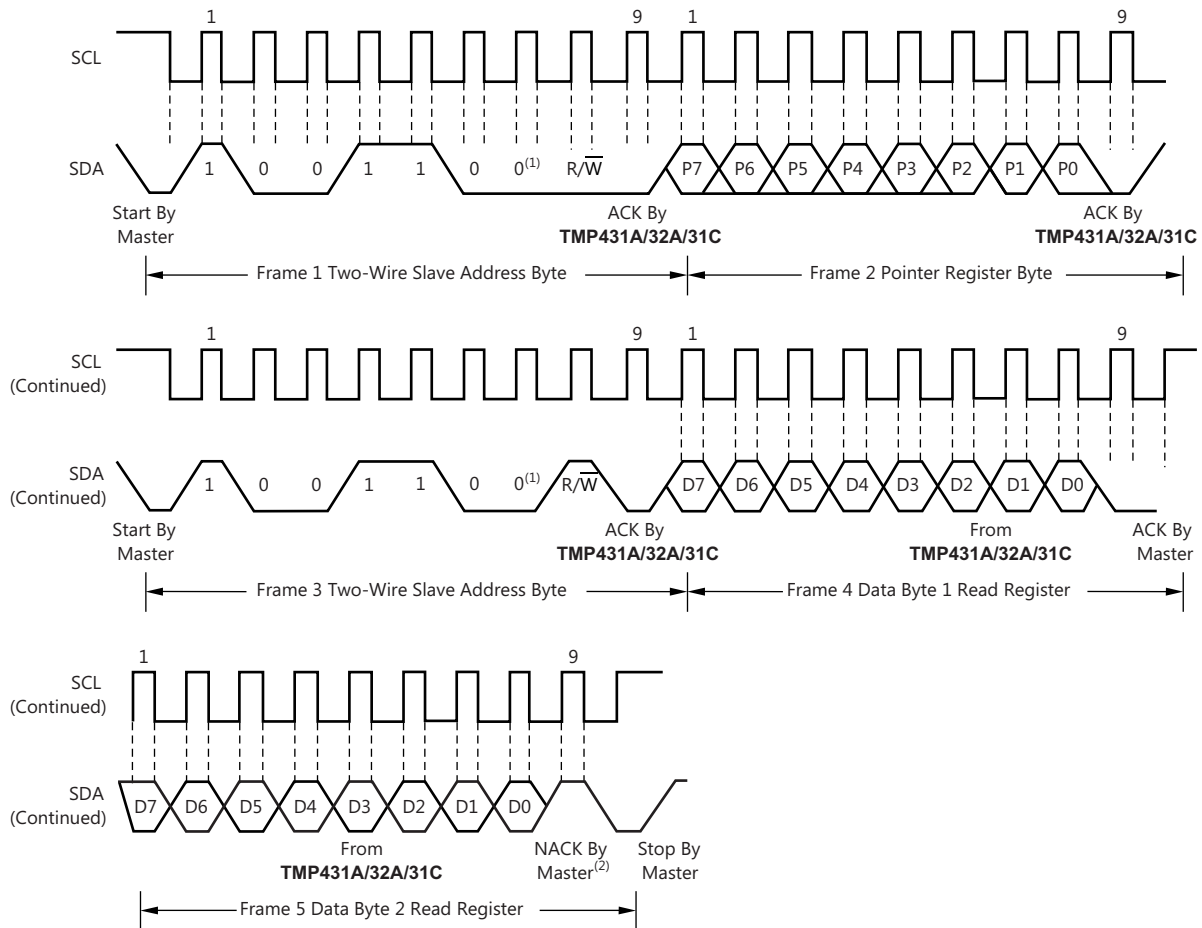

- (1) Slave address 1001100 (TMP431A, 32A, and 31C) shown. Slave address changes for TMP431B, 32B, and 31D. See [Mechanical, Packaging, and Orderable Information](#) for more details.
- (2) Master must leave SDA high to terminate a two-byte read operation.

Figure 16. Two-Wire Timing Diagram for Two-Byte Read Format

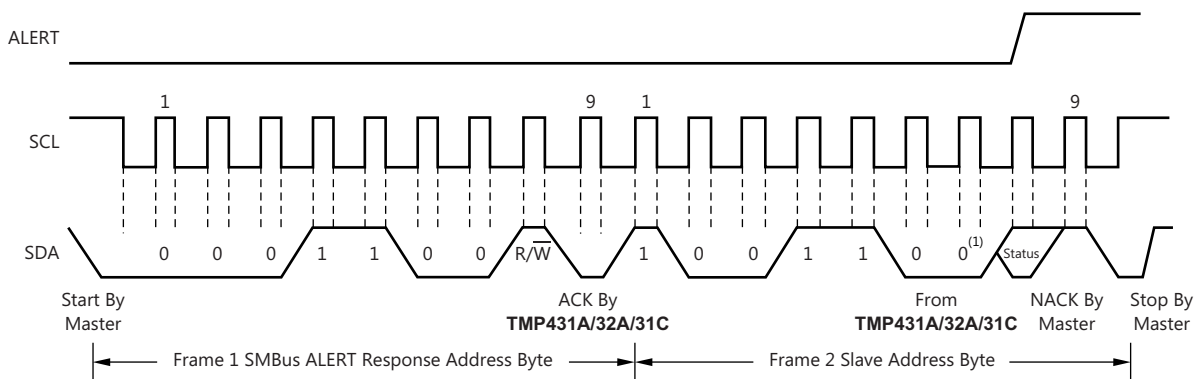

- (1) Slave address 1001100 (TMP431A, 32A, and 31C) shown. Slave address changes for TMP431B, 32B, and 31D. See [Mechanical, Packaging, and Orderable Information](#) for more details.

Figure 17. Timing Diagram for SMBus ALERT

Programming (continued)

8.5.4 Serial Bus Address

To communicate with the TMP43x, the master must first address slave devices via a slave address byte. The slave address byte consists of seven address bits, and a direction bit that indicates the intent of executing a read or write operation.

The address of the TMP431A, 32A, and 31C is 4Ch (1001100b). The address of the TMP431B, 32B, and 31D is 4Dh (1001101b).

8.5.5 Read and Write Operations

Accessing a particular register on the TMP43x is accomplished by writing the appropriate value to the Pointer Register. The value for the Pointer Register is the first byte transferred after the slave address byte with the R/W bit low. Every write operation to the TMP43x require a value for the Pointer Register (see [Figure 14](#)).

When reading from the TMP43x, the last value stored in the Pointer Register by a write operation is used to determine which register is read by a read operation. To change the register pointer for a read operation, a new value must be written to the Pointer Register. This transaction is accomplished by issuing a slave address byte with the R/W bit low, followed by the Pointer Register byte. No additional data are required. The master can then generate a START condition and send the slave address byte with the R/W bit high to initiate the read command. See [Figure 15](#) for details of this sequence. If repeated reads from the same register are desired, it is not necessary to continually send the Pointer Register bytes, because the TMP43x retain the Pointer Register value until it is changed by the next write operation. Note that register bytes are sent MSB first, followed by the LSB.

8.5.6 Undervoltage Lockout

The TMP43x sense when the power-supply voltage has reached a minimum voltage level for the ADC to function. The detection circuitry consists of a voltage comparator that enables the ADC after the power supply (V+) exceeds 2.45 V (typical). The comparator output is continuously checked during a conversion. The TMP43x do not perform a temperature conversion if the power supply is not valid. The last valid measured temperature is used for the temperature measurement result.

8.5.7 Timeout Function

The serial interface of the TMP43x resets if either SCL or SDA are held low for 32 ms (typical) between a START and STOP condition. If the TMP43x are holding the bus low, it releases the bus and waits for a START condition.

8.5.8 High-Speed Mode

For the Two-Wire bus to operate at frequencies above 400 kHz, the master device must issue a High-speed mode (Hs-mode) master code (00001XXX) as the first byte after a START condition to switch the bus to high-speed operation. The TMP43x do not acknowledge this byte, but switch the input filters on SDA and SCL and the output filter on SDA to operate in Hs-mode, allowing transfers at up to 2.5 MHz. After the Hs-mode master code has been issued, the master transmits a Two-Wire slave address to initiate a data transfer operation. The bus continues to operate in Hs-mode until a STOP condition occurs on the bus. Upon receiving the STOP condition, the TMP43x switch the input and output filter back to fast-mode operation.

8.5.9 General Call Reset

The TMP43x support reset through the Two-Wire General Call address 00h (0000 0000b). The TMP43x acknowledge the General Call address and respond to the second byte. If the second byte is 06h (0000 0110b), the TMP43x execute a software reset. This software reset restores the power-on reset state to all TMP43x registers, aborts any conversion in progress, and clears the ALERT and THERM pins. The TMP43x take no action in response to other values in the second byte.

Programming (continued)

8.5.10 SMBus Alert Function

The TMP43x support the SMBus Alert function. When pin 6 (for the TMP431) or pin 8 (for the TMP432) is configured as an alert output, the $\overline{\text{ALERT}}$ pin of the TMP43x can be connected as an SMBus Alert signal. When a master detects an alert condition on the $\overline{\text{ALERT}}$ line, the master sends an SMBus Alert command (00011001) on the bus. If the $\overline{\text{ALERT}}$ pin of the TMP43x is active, the devices acknowledge the SMBus Alert command and respond by returning the slave address on the SDA line. The eighth bit (LSB) of the slave address byte indicates whether the temperature exceeding one of the temperature high limit settings or falling below one of the temperature low limit settings caused the alert condition. This bit is high if the temperature is greater than or equal to one of the temperature high limit settings; this bit is low if the temperature is less than one of the temperature low limit settings. See [Figure 18](#) for details of this sequence.

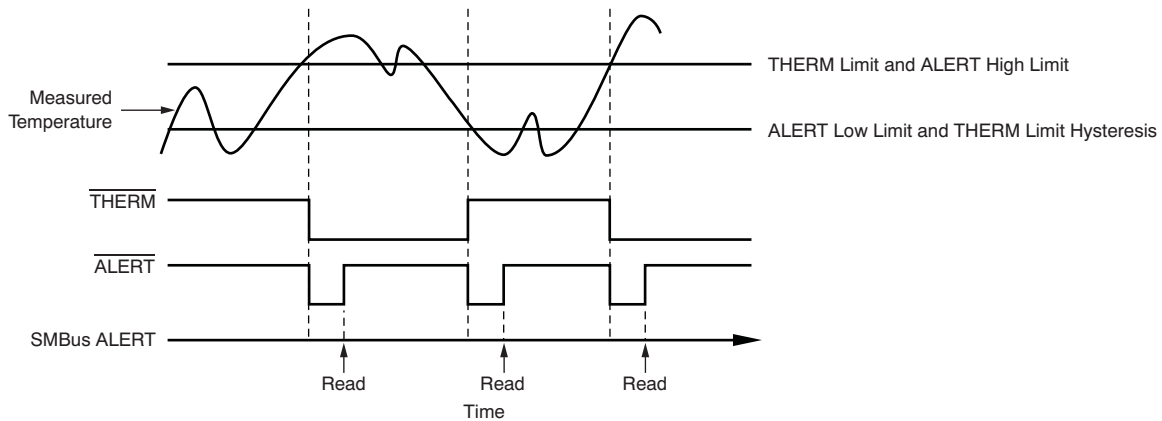

Figure 18. SMBus Alert Timing Diagram

If multiple devices on the bus respond to the SMBus Alert command, arbitration during the slave address portion of the SMBus Alert command determines which device clears its alert status. If the TMP43x win the arbitration, the $\overline{\text{ALERT}}$ pin becomes inactive at the completion of the SMBus Alert command. If the TMP43x lose the arbitration, the $\overline{\text{ALERT}}$ pin remains active.

8.6 Register Maps

The TMP43x contain multiple registers for holding configuration information, temperature measurement results, temperature comparator maximum, minimum, limits, and status information. These registers are described in [Figure 19](#) and in [Table 3](#) for the TMP431, and in [Table 4](#) for the TMP432.

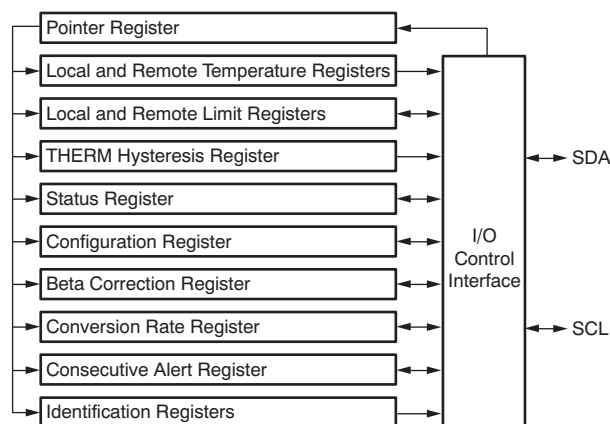

Figure 19. Internal Register Structure

Register Maps (continued)
Table 3. TMP431 Register Map

POINTER ADDRESS (HEX)		POWER-ON RESET (HEX)	BIT DESCRIPTIONS								REGISTER DESCRIPTIONS
READ	WRITE		D7	D6	D5	D4	D3	D2	D1	D0	
00	NA ⁽¹⁾	00	LT11	LT10	LT9	LT8	LT7	LT6	LT5	LT4	Local temperature (high byte)
01	NA	00	RT11	RT10	RT9	RT8	RT7	RT6	RT5	RT4	Remote temperature (high byte)
02	NA	80	BUSY	LHIGH	LLOW	RHIGH	RLOW	OPEN	RTHRM	LTHRM	Status register
03	09	00	MASK	SD	AL/TH	0	0	RANGE	0	0	Configuration register 1
04	0A	07	0	0	0	0	R3	R2	R1	R0	Conversion rate register
05	0B	55	LTH11	LTH10	LTH9	LTH8	LTH7	LTH6	LTH5	LTH4	Local temperature high limit (high byte)
06	0C	00	LTL11	LTL10	LTL9	LTL8	LTL7	LTL6	LTL5	LTL4	Local temperature low limit (high byte)
07	0D	55	RTH11	RTH10	RTH9	RTH8	RTH7	RTH6	RTH5	RTH4	Remote temperature high limit (high byte)
08	0E	00	RTL11	RTL10	RTL9	RTL8	RTL7	RTL6	RTL5	RTL4	Remote temperature low limit (high byte)
NA	0F	X ⁽²⁾	X	X	X	X	X	X	X	X	One-shot start
10	NA	00	RT3	RT2	RT1	RT0	0	0	0	0	Remote temperature (low byte)
13	13	00	RTH3	RTH2	RTH1	RTH0	0	0	0	0	Remote temperature high limit (low byte)
14	14	00	RTL3	RTL2	RTL1	RTL0	0	0	0	0	Remote temperature low limit (low byte)
15	NA	00	LT3	LT2	LT1	LT0	0	0	0	0	Local temperature (low byte)
16	16	00	LTH3	LTH2	LTH1	LTH0	0	0	0	0	Local temperature high limit (low byte)
17	17	00	LTL3	LTL2	LTL1	LTL0	0	0	0	0	Local temperature low limit (low byte)
18	18	00	NC7	NC6	NC5	NC4	NC3	NC2	NC1	NC0	N-factor correction
19	19	55 ⁽³⁾	RTHL7	RTHL6	RTHL5	RTHL4	RTHL3	RTHL2	RTHL1	RTHL0	Remote THERM limit
1A	1A	1C	0	0	0	REN	LEN	RC	0	0	Configuration register 2
1F	1F	00	0	0	0	0	0	0	RIMASK	LMASK	Channel mask
20	20	55 ⁽³⁾	LTHL7	LTHL6	LTHL5	LTHL4	LTHL3	LTHL2	LTHL1	LTHL0	Local THERM limit
21	21	0A	TH7	TH6	TH5	TH4	TH3	TH2	TH1	TH0	THERM hysteresis
22	22	70	0	CTH2	CTH1	CTH0	CALT2	CALT1	CALT0	0	Consecutive alert register
25	25	08	0	0	0	0	BC3	BC2	BC1	BC0	Beta range register
NA	FC	00	X ⁽⁴⁾	X	X	X	X	X	X	X	Software reset
FD	NA	31	0	0	1	1	0	0	0	1	TMP431 device ID
FE	NA	55	0	1	0	1	0	1	0	1	Manufacturer ID

(1) NA = Not applicable; register is write- or read-only.

(2) X = Indeterminate state.

(3) TMP431C and TMP431D versions have a power-on reset value of 69h.

(4) X = Undefined. Writing any value to this register initiates a software reset; see [Software Reset](#)

Table 4. TMP432 Register Map

POINTER ADDRESS		POWER-ON RESET (HEX)	BIT DESCRIPTIONS								REGISTER DESCRIPTIONS
READ	WRITE		D7	D6	D5	D4	D3	D2	D1	D0	
00	NA ⁽¹⁾	00	LT11	LT10	LT9	LT8	LT7	LT6	LT5	LT4	Local temperature (high byte)
01	NA	00	RT11	RT10	RT9	RT8	RT7	RT6	RT5	RT4	Remote temperature1 (high byte)
02	NA	80	BUSY	0	0	HIGH	LOW	OPEN	THERM	0	Status register
03	09	00	MASK	SD	AL/TH	0	0	RANGE	0	0	Configuration register1
04	0A	07	0	0	0	0	R3	R2	R1	R0	Conversion rate register
05	0B	55	LTH11	LTH10	LTH9	LTH8	LTH7	LTH6	LTH5	LTH4	Local temperature high limit (high byte)
06	0C	00	LTL11	LTL10	LTL9	LTL8	LTL7	LTL6	LTL5	LTL4	Local temperature low limit (high byte)
07	0D	55	RTH11	RTH10	RTH9	RTH8	RTH7	RTH6	RTH5	RTH4	Remote temperature1 high limit (high byte)
08	0E	00	RTL11	RTL10	RTL9	RTL8	RTL7	RTL6	RTL5	RTL4	Remote temperature1 low limit (high byte)
NA	0F	X ⁽²⁾	X	X	X	X	X	X	X	X	One-shot start
10	NA	00	RT3	RT2	RT1	RT0	0	0	0	0	Remote temperature1 (low byte)
13	13	00	RTH3	RTH2	RTH1	RTH0	0	0	0	0	Remote temperature1 high limit (low byte)
14	14	00	RTL3	RTL2	RTL1	RTL0	0	0	0	0	Remote temperature1 low limit (low byte)
15	15	55	RTH11	RTH10	RTH9	RTH8	RTH7	RTH6	RTH5	RTH4	Remote temperature2 high limit (high byte)
16	16	00	RTL11	RTL10	RTL9	RTL8	RTL7	RTL6	RTL5	RTL4	Remote temperature2 low limit (high byte)
17	17	00	RTH3	RTH2	RTH1	RTH0	0	0	0	0	Remote temperature2 high limit (low byte)
18	18	00	RTL3	RTL2	RTL1	RTL0	0	0	0	0	Remote temperature2 low limit (low byte)
19	19	55	RTHL7	RTHL6	RTHL5	RTHL4	RTHL3	RTHL2	RTHL1	RTHL0	Remote therm limit
1A	1A	55	RTHL7	RTHL6	RTHL5	RTHL4	RTHL3	RTHL2	RTHL1	RTHL0	Remote2 therm limit
1B	1B	00	0	0	0	0	0	R2OPEN	R1OPEN	0	Open status
1F	1F	00	0	0	0	0	0	R2MASK	R1MASK	LMASK	Channel mask
20	20	55	LTHL7	LTHL6	LTHL5	LTHL4	LTHL3	LTHL2	LTHL1	LTHL0	Local therm limit
21	21	0A	TH7	TH6	TH5	TH4	TH3	TH2	TH1	TH0	Therm limit hysteresis
22	22	70	0	CTH2	CTH1	CTH0	CALT2	CALT1	CALT0	0	Consecutive alert register
23	NA	00	RT11	RT10	RT9	RT8	RT7	RT6	RT5	RT4	Remote temperature2 (high byte)
24	NA	00	RT3	RT2	RT1	RT0	0	0	0	0	Remote temperature2 (low byte)
25	25	08	0	0	0	0	BC3	BC2	BC1	BC0	Ch. 1 beta range selection
26	26	08	0	0	0	0	BC3	BC2	BC1	BC0	Ch. 2 beta range selection
27	27	00	NC7	NC6	NC5	NC4	NC3	NC2	NC1	NC0	N-factor correction remote1
28	28	00	NC7	NC6	NC5	NC4	NC3	NC2	NC1	NC0	N-factor correction remote2

(1) NA = Not applicable; register is write- or read-only.

(2) Indeterminate state.

Table 4. TMP432 Register Map (continued)

POINTER ADDRESS		POWER-ON RESET (HEX)	BIT DESCRIPTIONS								REGISTER DESCRIPTIONS
READ	WRITE		D7	D6	D5	D4	D3	D2	D1	D0	
29	NA	00	T3	T2	T1	T0	0	0	0	0	Local temperature (low byte)
35	35	00	0	0	0	0	0	R2HIGH	R1HIGH	LHIGH	High limit status
36	36	00	0	0	0	0	0	R2LOW	R1LOW	LLOW	Low limit status
37	37	00	0	0	0	0	0	R2THERM	R1THERM	LTHERM	Therm status
3D	3D	00	LTH3	LTH2	LTH1	LTH0	0	0	0	0	Local temperature high limit (low byte)
3E	3E	00	LTL3	LTL2	LTL1	LTL0	0	0	0	0	Local temperature low limit (low byte)
3F	3F	3C	0	0	REN2	REN	LEN	RC	0	0	Configuration register2
NA	FC	00	X ⁽³⁾	X	X	X	X	X	X	X	Software reset
FD	NA	32	0	0	1	1	0	0	1	0	TMP432 device ID
FE	NA	55	0	1	0	1	0	1	0	1	Manufacturer ID

(3) X = Undefined. Writing any value to this register initiates a software reset; see [Software Reset](#).

8.6.1 Pointer Register

[Figure 19](#) illustrates the internal register structure of the TMP43x. The 8-bit Pointer Register is used to address a given data register. The Pointer Register identifies which of the data registers must respond to a read or write command on the Two-Wire bus. This register is set with every write command. A write command must be issued to set the proper value in the Pointer Register before executing a read command. [Table 3](#) describes the pointer address of the registers available in the TMP431. [Table 4](#) describes the address of the registers available in the TMP432. The power-on reset (POR) value of the Pointer Register is 00h (0000 0000b).

8.6.2 Temperature Registers

The TMP431 has four 8-bit registers that hold temperature measurement results. The TMP432 has six 8-bit registers that hold temperature measurement results. Both the local channel and the remote channel have a high byte register that contains the most significant bits (MSBs) of the temperature analog-to-digital converter (ADC) result and a low byte register that contains the least significant bits (LSBs) of the temperature ADC result. The local channel high byte address for the TMP43x is 00h; the local channel low byte address is 15h for the TMP431 and 29h for the TMP432. The remote channel high byte is at address 01h; the remote channel low byte address is 10h. For the TMP432, the second remote channel high byte address is 23h; the second remote channel low byte is 24h. These registers are read-only and are updated by the ADC each time a temperature measurement is completed.

The TMP43x contain circuitry to assure that a low byte register read command returns data from the same ADC conversion as the immediately preceding high byte read command. This assurance remains valid only until another register is read. For proper operation, the high byte of a temperature register must be read first. The low byte register must be read in the next read command. The low byte register can be left unread if the LSBs are not needed. Alternatively, the temperature registers can be read as a 16-bit register by using a single two-byte read command from address 00h for the local channel result, or from address 01h for the remote channel result (23h for the second remote channel result). The high byte is output first, followed by the low byte. Both bytes of this read operation are from the same ADC conversion. The power-on reset value of both temperature registers is 00h.

8.6.3 Limit Registers

The TMP43x have registers for setting comparator limits for both the local and remote measurement channels. These registers have read and write capability. The High and Low Limit Registers for both channels span two registers, as do the temperature registers. The local temperature high limit is set by writing the high byte to pointer address 0Bh and writing the low byte to pointer address 16h for the TMP431 and 3Dh for the TMP432, or by using a single two-byte write command (high byte first) to pointer address 0Bh.

The local temperature high limit is obtained by reading the high byte from pointer address 05h and the low byte from pointer address 16h for the TMP431 and 3Dh for the TMP432, or by using a two-byte read command from pointer address 05h. The power-on reset value of the local temperature high limit is 55h, 00h (85°C in standard temperature mode; 21°C in extended temperature mode).

Similarly, the local temperature low limit is set by writing the high byte to pointer address 0Ch and writing the low byte to pointer address 17h for the TMP431 and 3Eh for the TMP432, or by using a single two-byte write command to pointer address 0Ch. The local temperature low limit is read by reading the high byte from pointer address 06h and the low byte from pointer address 17h and 3Eh for the TMP432, or by using a two-byte read from pointer address 06h. The power-on reset value of the local temperature low limit register is 00h, 00h (0°C in standard temperature mode; –64°C in extended mode).

The remote temperature high limit for the TMP431 (remote temperature1 high limit for the TMP432) is set by writing the high byte to pointer address 0Dh and writing the low byte to pointer address 13h, or by using a two-byte write command to pointer address 0Dh. The remote temperature high limit is obtained by reading the high byte from pointer address 07h and the low byte from pointer address 13h, or by using a two-byte read command from pointer address 07h. The power-on reset value of the Remote Temperature High Limit Register is 55h, 00h (85°C in standard temperature mode; 21°C in extended temperature mode).

The remote temperature low limit for the TMP431 (remote temperature1 low limit for the TMP432) is set by writing the high byte to pointer address 0Eh and writing the low byte to pointer address 14h, or by using a two-byte write to pointer address 0Eh. The remote temperature low limit is read by reading the high byte from pointer address 08h and the low byte from pointer address 14h, or by using a two-byte read from pointer address 08h. The power-on reset value of the Remote Temperature Low Limit Register is 00h, 00h (0°C in standard temperature mode; –64°C in extended mode).

The remote temperature2 high limit for the TMP432 is set by writing the high byte to pointer address 15h and writing the low byte to pointer address 17h, or by using a two-byte write command to pointer address 15h. The remote temperature high limit is obtained by reading the high byte from pointer address 15h and the low byte from pointer address 17h, or by using a two-byte read command from pointer address 15h. The power-on reset value of the Remote Temperature High Limit Register is 55h, 00h (85°C in standard temperature mode; 21°C in extended temperature mode).

The remote temperature2 low limit for the TMP432 is set by writing the high byte to pointer address 16h and writing the low byte to pointer address 18h, or by using a two-byte write to pointer address 16h. The remote temperature low limit is read by reading the high byte from pointer address 16h and the low byte from pointer address 18h, or by using a two-byte read from pointer address 16h. The power-on reset value of the Remote Temperature Low Limit Register is 00h, 00h (0°C in standard temperature mode; –64°C in extended mode).

The TMP43x also have a THERM limit register for both the local and the remote channels. These registers are eight bits and allow for THERM limits set to 1°C resolution. The local channel THERM limit is set by writing to pointer address 20h. The remote channel THERM limit is set by writing to pointer address 19h. The remote channel THERM2 limit for the TMP432 is set by writing to pointer address 1Ah.

The local channel THERM limit is obtained by reading from pointer address 20h; the remote channel THERM limit is read by reading from pointer address 19h. The remote channel THERM2 limit is read by reading from pointer address 1Ah. The power-on reset value of the THERM limit registers is 55h for the TMP431A, TMP431B, TMP432A, and TMP432B (85°C in standard temperature mode; 21°C in extended temperature mode). The power-on reset value of the THERM limit registers is 69h for the TMP431C and TMP431D (105°C in standard temperature mode; 41°C in extended temperature mode). The THERM limit comparators also have hysteresis. The hysteresis of both comparators is set by writing to pointer address 21h. The hysteresis value is obtained by reading from pointer address 21h. The value in the Hysteresis Register is an unsigned number (always positive). The power-on reset value of this register is 0Ah (+10°C).

NOTE

Whenever changing between standard and extended temperature ranges, be aware that the temperatures stored in the temperature limit registers are not automatically reformatted to correspond to the new temperature range format. These values must be reprogrammed in the appropriate binary or extended binary format.

8.6.4 Status Registers

8.6.4.1 TMP431 Status Register

Table 5. TMP431 Status Register Format

TMP431 STATUS REGISTER (Read = 02h, Write = NA)								
BIT #	D7	D6	D5	D4	D3	D2	D1	D0
BIT NAME	BUSY	LHIGH	LLOW	RHIGH	RLOW	OPEN	RTHRM	LTHRM
POR VALUE	0 ⁽¹⁾	0	0	0	0	0	0	0

(1) The BUSY bit changes to 1 almost immediately ($\ll 100 \mu\text{s}$) following power-up, as the TMP431 begins the first temperature conversion. It is high whenever the TMP431 is converting a temperature reading.

The TMP431 has a Status Register to report the state of the temperature comparators. Table 5 shows the Status Register bits. The Status Register is read-only and is read by reading from pointer address 02h.

The BUSY bit reads as 1 if the ADC is making a conversion. This bit reads as 0 if the ADC is not converting.

The OPEN bit reads as 1 if the remote transistor is detected as open from the last read of the Status Register. The OPEN status is only detected when the ADC is attempting to convert a remote temperature.

The RTHRM bit reads as 1 if the remote temperature exceeds the remote THERM limit and remains greater than the remote THERM limit less the value in the shared Hysteresis Register; see Figure 18.

The LTHRM bit reads as 1 if the local temperature exceeds the local THERM limit and remains greater than the local THERM limit less the value in the shared Hysteresis Register; see Figure 18.

The LHIGH and RHIGH bit values depend on the state of the $\overline{\text{AL/TH}}$ bit in the Configuration Register 1. If the $\overline{\text{AL/TH}}$ bit is '0', the LHIGH bit reads as 1 if the local high limit was exceeded from the last clearing of the Status Register. The RHIGH bit reads as 1 if the remote high limit was exceeded from the last clearing of the Status Register. If the $\overline{\text{AL/TH}}$ bit is 1, the remote high limit and the local high limit are used to implement a THERM2 function. LHIGH reads as 1 if the local temperature exceeds the local high limit and remains greater than the local high limit less the value in the Hysteresis Register.

The RHIGH bit reads as 1 if the remote temperature has exceeded the remote high limit and remains greater than the remote high limit less the value in the Hysteresis Register.

The LLOW and RLOW bits are not affected by the $\overline{\text{AL/TH}}$ bit. The LLOW bit reads as 1 if the local low limit was exceeded from the last clearing of the Status Register. The RLOW bit reads as 1 if the remote low limit was exceeded from the last clearing of the Status Register.

The values of the LLOW, RLOW, and OPEN (as well as LHIGH and RHIGH when $\overline{\text{AL/TH}}$ is 0) are latched and read as 1 until the Status Register is read or a device reset occurs. These bits are cleared by reading the Status Register, provided that the condition causing the flag to be set no longer exists. The values of BUSY, LTHRM, and RTHRM (as well as LHIGH and RHIGH when $\overline{\text{ALERT/THERM2}}$ is 1) are not latched and are not cleared by reading the Status Register. They always indicate the current state, and are updated appropriately at the end of the corresponding ADC conversion. Clearing the Status Register bits does not clear the state of the $\overline{\text{ALERT}}$ pin; an SMBus alert response address command must be used to clear the $\overline{\text{ALERT}}$ pin.

The TMP431 NORs LHIGH, LLOW, RHIGH, RLOW, and OPEN, so a status change for any of these flags from 0 to 1 automatically causes the $\overline{\text{ALERT}}$ pin to go low (only applies when the $\overline{\text{ALERT/THERM2}}$ pin is configured for ALERT mode).

8.6.4.2 TMP432 Status Register

Table 6. TMP432 Status Register Format

TMP432 STATUS REGISTER (Read = 02h, Write = NA)								
BIT #	D7	D6	D5	D4	D3	D2	D1	D0
BIT NAME	BUSY	0	0	HIGH	LOW	OPEN	THERM	0
POR VALUE	0 ⁽¹⁾	0	0	0	0	0	0	0

(1) The BUSY bit changes to 1 almost immediately ($\ll 100 \mu\text{s}$) following power-up, as the TMP432 begins the first temperature conversion. It is high whenever the TMP432 is converting a temperature reading.

The TMP432 has a Status Register to report the state of the temperature comparators. [Table 6](#) lists the Status Register bits. The Status Register is read-only and is read by reading from pointer address 02h.

The BUSY bit reads as 1 if the ADC is making a conversion. It reads as 0 if the ADC is not converting.

The OPEN bit reads as 1 if the remote transistor was detected as open from the last read of the Status Register. The OPEN status is only detected when the ADC is attempting to convert a remote temperature.

The THERM bit reads as 1 if the temperature from any channel (remote or local) has exceeded the THERM limit and remains greater than the THERM limit less the value in the shared Hysteresis Register; see [Figure 18](#).

The HIGH bit value depends on the state of the $\overline{\text{AL/TH}}$ bit in the Configuration Register 1. If the $\overline{\text{AL/TH}}$ bit is 0, the HIGH bit reads 1 if any of the temperature channels go beyond the programmed high limit from the last clearing of the Status Register. If the $\overline{\text{AL/TH}}$ bit is 1, the HIGH limit is used to implement THERM2 function. The HIGH bit reads as 1 if the temperature exceeds the high limit less the value in the Hysteresis Register.

The $\overline{\text{AL/TH}}$ bit does not affect the Status Register LOW bit. The LOW bit reads as 1 if any of the temperature channels go beyond the programmed low limit from the last clearing of the Status Register.

The values of the LOW and OPEN bits (as well as HIGH when $\overline{\text{AL/TH}}$ is 0) are latched and read as 1 until the corresponding Status Register is read or a device reset occurs. These bits are cleared by reading the Low Limit Status, High Limit Status, and Open Status registers if the condition causing the flag to be set no longer exists.

The values of BUSY and THERM (as well as HIGH when $\overline{\text{AL/TH}}$ is 1) are not latched and are not cleared by reading the Status Register. They always indicate the current state, and are updated appropriately at the end of the corresponding ADC conversion. Clearing the Status Register bits does not clear the state of the $\overline{\text{ALERT}}$ pin; an SMBus alert response address command must be used to clear the $\overline{\text{ALERT}}$ pin.

The TMP432 NORs HIGH, LOW, and OPEN, so a status change for any of these flags from 0 to 1 automatically causes the $\overline{\text{ALERT}}$ pin to go low (only applies when the $\overline{\text{ALERT/THERM2}}$ pin is configured for ALERT mode).

8.6.5 Configuration Register 1

The Configuration Register 1 sets the temperature range, controls shutdown mode, and determines how the $\overline{\text{ALERT/THERM2}}$ pin functions. The Configuration Register is set by writing to pointer address 09h and read by reading from pointer address 03h.

The MASK bit (bit 7) enables or disables the $\overline{\text{ALERT}}$ pin output if $\overline{\text{ALERT/THERM}} = 0$. If $\overline{\text{ALERT/THERM}} = 1$ then the MASK bit has no effect. If MASK is set to '0', the $\overline{\text{ALERT}}$ pin goes low when one of the temperature measurement channels exceeds its high or low limits for the chosen number of consecutive conversions. If the MASK bit is set to 1, the TMP43x retain the $\overline{\text{ALERT}}$ pin status, but the $\overline{\text{ALERT}}$ pin does not go low.

The shutdown (SD) bit (bit 6) enables or disables the temperature measurement circuitry. If $\text{SD} = 0$, the TMP43x convert continuously at the rate set in the conversion rate register. When SD is set to 1, the TMP43x immediately stop converting and enter a shutdown mode. When SD is set to 0 again, the TMP43x resume continuous conversions. A single conversion can be started when $\text{SD} = 1$ by writing to the One-Shot Register.

The $\overline{\text{AL/TH}}$ bit (bit 5) controls whether the $\overline{\text{ALERT}}$ pin functions in ALERT mode or THERM2 mode. If $\overline{\text{AL/TH}} = 0$, the $\overline{\text{ALERT}}$ pin operates as an interrupt pin. In this mode, the $\overline{\text{ALERT}}$ pin goes low after the set number of consecutive out-of-limit temperature measurements occur.

If $\overline{\text{AL/TH}} = 1$, the $\overline{\text{ALERT/THERM2}}$ pin implements a THERM function ($\overline{\text{THERM2}}$). In this mode, $\overline{\text{THERM2}}$ functions similar to the THERM pin except that the local high limit and remote high limit registers are used for the thresholds. $\overline{\text{THERM2}}$ goes low when either RHIGH or LHIGH is set.

The temperature range is set by configuring bit 2 of the Configuration Register 1. Setting this bit low configures the TMP43x for the standard measurement range (0°C to 127°C); temperature conversions will be stored in the standard binary format. Setting bit 2 high configures the TMP43x for the extended measurement range (–55°C to 150°C); temperature conversions are stored in the extended binary format (see [Table 1](#)).

The remaining bits of the Configuration Register 1 are reserved and must always be set to 0. The power-on reset value for this register is 00h. [Table 7](#) summarizes the bits of the Configuration Register 1.

Table 7. Configuration Register 1 Bit Descriptions

CONFIGURATION REGISTER 1 (Read = 03h, Write = 09h, POR = 00h)			
BIT	NAME	FUNCTION	POWER-ON RESET VALUE
7	MASK	0 = ALERT enabled 1 = ALERT masked	0
6	SD	0 = Run 1 = Shut down	0
5	$\overline{AL/TH}$	0 = ALERT mode 1 = THERM mode	0
4, 3	Reserved	—	0
2	Temperature range	0 = 0°C to 127°C 1 = -55°C to 150°C	0
1, 0	Reserved	—	0

8.6.6 Configuration Register 2

Configuration Register 2 (pointer address 1Ah for the TMP431 and 3Fh for the TMP432) controls which temperature measurement channels are enabled and whether the external channels have the resistance correction feature enabled or not.

The RC bit enables the resistance correction feature for the external temperature channels. If RC = 1, series resistance correction is enabled; if RC = 0, resistance correction is disabled. Resistance correction must be enabled for most applications. However, disabling the resistance correction can yield slightly improved temperature measurement noise performance, and reduce conversion time by about 50%, which could lower power consumption when conversion rates of two per second or less are selected.

The LEN bit enables the local temperature measurement channel. If LEN = 1, the local channel is enabled; if LEN = 0, the local channel is disabled.

The REN bit enables external temperature measurement channel 1 (connected to pins 2 and 3.) If REN = 1, the external channel is enabled; if REN = 0, the external channel is disabled.

For the TMP432 only, the REN2 bit enables the second external measurement channel (connected to pins 4 and 5). If REN2 = 1, the second external channel is enabled; if REN2 = 0, the second external channel is disabled.

The temperature measurement sequence is local channel, external channel 1, external channel 2, shutdown, and delay (to set conversion rate, if necessary). The sequence starts over with the local channel. If any of the channels are disabled, they are skipped in the sequence. [Table 8](#) summarizes the bits of Configuration Register 2.

Table 8. Configuration Register 2 Bit Descriptions

CONFIGURATION REGISTER 2 (Read, Write = 1 A for TMP431 3F for TMP432; POR = 1Ch for TMP431; 3Ch for TMP432)			
BIT	NAME	FUNCTION	POWER-ON RESET VALUE
7, 6	Reserved	—	0
5	REN2	0 = External channel 2 disabled 1 = External channel 2 enabled	0 (TMP431) 1 (TMP432)
4	REN	0 = External channel 1 disabled 1 = External channel 1 enabled	1
3	LEN	0 = Local channel disabled 1 = Local channel enabled	1
2	RC	0 = Resistance correction disabled 1 = Resistance correction enabled	1
1, 0	Reserved	—	0

8.6.7 Conversion Rate Register

The Conversion Rate Register (pointer address 0Ah) controls the rate at which temperature conversions are performed. This register adjusts the idle time between conversions but not the conversion timing itself, thereby allowing the TMP43x power dissipation to be balanced with the temperature register update rate. [Table 9](#) shows the conversion rate options and corresponding current consumption.

Table 9. Conversion Rate Register

CONVERSION RATE REGISTER (Read = 04h, Write = 0Ah, POR = 07h)										
R7	R6	R5	R4	R3	R2	R1	R0	CONVERSION PER SEC	AVERAGE I _Q (TYP) (μA)	
									V ₊ = 2.7 V	V ₊ = 5.5 V
0	0	0	0	0	0	0	0	0.0625	11	32
0	0	0	0	0	0	0	1	0.125	17	38
0	0	0	0	0	0	1	0	0.25	28	49
0	0	0	0	0	0	1	1	0.5	47	69
0	0	0	0	0	1	0	0	1	80	103
0	0	0	0	0	1	0	1	2	128	155
0	0	0	0	0	1	1	0	4	190	220
07h to 0Fh								8	373	413

8.6.8 Beta Compensation Configuration Register

If the Beta Compensation Configuration Register is set to 1xxx (beta correction enabled) for a given remote channel at the beginning of each temperature conversion, the TMP43x automatically detect if the sensor is diode-connected or GND collector-connected, select the proper beta range, and measure the sensor temperature appropriately.

If the Beta Compensation Configuration Register is set to 0111 (beta correction disabled) for a given channel, the automatic detection is bypassed and the temperature is measured assuming a diode-connected sensor. A PNP transistor can continue to be GND collector-connected in this mode, but no beta compensation factor is applied. When the beta correction is set to 0111 or the sensor is diode-connected (base shorted to collector), the η -factor used by the TMP43x is 1.008. When the beta correction configuration is set to 1xxx (beta correction enabled) and the sensor is GND collector-connected (PNP collector to ground), the η -factor used by the TMP43x is 1.000. [Table 10](#) shows the read value for the selected beta ranges and the appropriate η -factor used for each conversion.

Table 10. Beta Compensation Configuration Register

BCx3-BCx0	BETA RANGE DESCRIPTION	η -FACTOR	TIME
1000	Automatically selected range 0 (0.10 < beta < 0.18)	1	126 ms
1001	Automatically selected range 1 (0.16 < beta < 0.26)	1	126 ms
1010	Automatically selected range 2 (0.24 < beta < 0.43)	1	126 ms
1011	Automatically selected range 3 (0.35 < beta < 0.78)	1	126 ms
1100	Automatically selected range 4 (0.64 < beta < 1.8)	1	126 ms
1101	Automatically selected range 5 (1.4 < beta < 9)	1	126 ms
1110	Automatically selected range 6 (6.7 < beta < 40)	1	126 ms
1111	Automatically selected range 7 (beta > 27)	1	126 ms
1111	Automatically detected diode connected sensor	1.008	93 ms
0000	Manually selected range 0 (0.10 < beta < 0.5)	1	93 ms
0001	Manually selected range 1 (0.13 < beta < 1)	1	93 ms
0010	Manually selected range 2 (0.18 < beta < 2)	1	93 ms
0011	Manually selected range 3 (0.3 < beta < 25)	1	93 ms
0100	Manually selected range 4 (0.5 < beta < 50)	1	93 ms
0101	Manually selected range 5 (1.1 < beta < 100)	1	93 ms
0110	Manually selected range 6 (2.4 < beta < 150)	1	93 ms
0111	Manually disabled beta correction	1.008	93 ms

8.6.9 η -Factor Correction Register

The TMP43x allow for a different η -factor value to be used for converting remote channel measurements to temperature. The remote channel uses sequential current excitation to extract a differential V_{BE} voltage measurement to determine the temperature of the remote transistor. Equation 1 relates this voltage and temperature.

$$V_{BE2} - V_{BE1} = \frac{\eta kT}{q} \ln\left(\frac{I_2}{I_1}\right) \quad (1)$$

The value η in Equation 1 is a characteristic of the particular transistor used for the remote channel. When the beta compensation configuration is set to 0111 (beta compensation disabled) or the sensor is diode-connected (base shorted to collector), the η -factor used by the TMP43x is 1.008. When the beta compensation configuration is set to 1000 (beta compensation enabled) and the sensor is GND collector-connected (PNP collector to ground), the η -factor used by the TMP43x is 1. If the η -factor used for the temperature conversion does not match the characteristic of the sensor, then temperature offset is observed. The value in the η -Factor Correction Register can be used to adjust the effective η -factor according to Equation 2 and Equation 3 for disabled beta compensation or a diode-connected sensor. Equation 4 and Equation 5 can be used for enabled beta compensation and a GND collector-connected sensor.

$$\eta_{\text{eff}} = \frac{1.008 \times 300}{300 - N_{\text{ADJUST}}} \quad (2)$$

$$N_{\text{ADJUST}} = 300 - \frac{300 \times 1.008}{\eta_{\text{eff}}} \quad (3)$$

$$\eta_{\text{eff}} = \frac{1.000 \times 300}{300 - N_{\text{ADJUST}}} \quad (4)$$

$$N_{\text{ADJUST}} = 300 - \frac{300 \times 1.000}{\eta_{\text{eff}}} \quad (5)$$

The η -correction value must be stored in two's-complement format, yielding an effective data range from –128 to 127. Table 11 shows the η -factor range for both 1.008 and 1. For the TMP431, the η -correction value can be written to and read from pointer address 18h. For the TMP432, the η -correction value can be written to and read from pointer address 27h. The η -correction value for the second remote channel is read to and written from pointer address 28h. The register power-on reset value is 00h, thus having no effect unless written to.

Table 11. η -Factor Range

BINARY	N_{ADJUST}		η
	HEX	DECIMAL	
01111111	7F	127	1.747977
00001010	0A	10	1.042759
00001000	08	8	1.035616
00000110	06	6	1.028571
00000100	04	4	1.021622
00000010	02	2	1.014765
00000001	01	1	1.011371
00000000	00	0	1.008
11111111	FF	–1	1.004651
11111110	FE	–2	1.001325
11111100	FC	–4	0.994737
11111010	FA	–6	0.988235
11111000	F8	–8	0.981818
11110110	F6	–10	0.975484
10000000	80	–128	0.706542

8.6.10 Software Reset

The TMP43x can be reset by writing any value to Pointer Register FCh. This action restores the power-on reset state to all of the TMP43x registers as well as abort any conversion in process and clear the ALERT and THERM pins.

The TMP43x also support reset via the two-wire general call address (00000000). The TMP43x acknowledge the general call address and respond to the second byte. If the second byte is 00000110, the TMP43x execute a software reset. The TMP43x do not respond to other values in the second byte.

8.6.11 Consecutive Alert Register

The value in the Consecutive Alert Register (address 22h) determines how many consecutive out-of-limit measurements must occur on a measurement channel before the ALERT or the THERM signal is activated. The value in this register does not affect bits in the Status Register. Values of one, two, three, or four consecutive conversions can be selected; one conversion is the default. This function allows additional filtering for the ALERT or the THERM pin. Table 14 shows the consecutive alert bits. For bit descriptions, see Table 12.

Table 12. Consecutive Alert Register Bit Descriptions

BIT NAME			NUMBER OF CONSECUTIVE OUT-OF-LIMIT MEASUREMENTS (ALERT/THERM)
CALT2/CTH2	CALT1/CTH1	CALT0/CTH0	
0	0	0	1
0	0	1	2
0	1	1	3
1	1	1	4

8.6.12 Therm Hysteresis Register

The THERM Hysteresis Register (see Table 15) stores the hysteresis value used for the THERM pin alarm function. This register must be programmed with a value that is less than the Local Temperature High Limit Register value, Remote Temperature High Limit Register value, Local THERM Limit Register value, or Remote THERM Limit Register value; otherwise, the respective temperature comparator does not trip on the measured temperature falling edges. Allowable hysteresis values are I in Table 13. The default hysteresis value is 10°C, whether the device is operating in the standard or extended mode setting.

Table 13. Allowable THERM Hysteresis Values

TEMPERATURE (°C)	THERM HYSTERESIS VALUE	
	TH[7:0] (STANDARD BINARY)	(HEX)
0	0000 0000	00
1	0000 0001	01
5	0000 0101	05
10	0000 1010	0A
25	0001 1001	19
50	0011 0010	32
75	0100 1011	4B
100	0110 0100	64
125	0111 1101	7D
127	0111 1111	7F
150	1001 0110	96
175	1010 1111	AF
200	1100 1000	C8
225	1110 0001	E1
255	1111 1111	FF

8.6.13 Identification Registers

The TMP43x allow for the Two-Wire bus controller to query the device for manufacturer and device IDs to enable the device for software identification of the device at the particular Two-Wire bus address. The manufacturer ID is obtained by reading from pointer address FEh. The TMP43x both return 55h for the manufacturer code. The device ID is obtained by reading from pointer address FDh. The TMP431 returns 31h for the device ID and the TMP432 returns 32h for the device ID (see [Table 3](#) and [Table 4](#)). These registers are read-only.

Table 14. Consecutive Alert Register Format

CONSECUTIVE ALERT REGISTER (READ = 22h, WRITE = 22h, POR = 70h)								
BIT #	D7	D6	D5	D4	D3	D2	D1	D0
BIT NAME	0	CTH2	CTH1	CTH0	CALT2	CALT1	CALT0	0
POR VALUE	0	1	1	1	0	0	0	0

Table 15. THERM Hysteresis Register Format

THERM HYSTERESIS REGISTER (Read = 21h, Write = 21h, POR = 0Ah)								
BIT #	D7	D6	D5	D4	D3	D2	D1	D0
BIT NAME	TH7	TH6	TH5	TH4	TH3	TH2	TH1	TH0
POR VALUE	0	0	0	0	1	0	1	0

8.6.14 Open Status Register

The Open Status Register indicates if there is a fault on the remote channel diode. Bit 2 is set if remote channel 2 is open or faultily connected. Similarly, bit 1 corresponds to remote channel 1. These bits are cleared by reading this register if the condition causing the flag to be set no longer exists.

8.6.15 Channel Mask Register

The Channel Mask Register controls individual channel masking. When a channel is masked, the $\overline{\text{ALERT}}$ pin is asserted when the masked channel reads a diode fault or out-of-limit error.

8.6.16 High Limit Status Register

The High Limit Status Register contains the status bits that are set when a temperature channel high limit is exceeded. If any of these bits are set, then the HIGH status bit in the Status Register is set. These bits are cleared by reading this register if the condition causing the flag to be set no longer exists.

8.6.17 Low Limit Status Register

The Low Limit Status Register contains the status bits that are set when a temperature channel low limit is exceeded. If any of these bits are set, then the LOW status bit in the Status Register is set. These bits are cleared by reading this register if the condition causing the flag to be set no longer exists.

8.6.18 THERM Limit Status Register

The THERM Limit Status Register contains the status bits that are set when a temperature channel THERM limit is exceeded. If any of these bits are set, then the THERM status bit in the Status Register is set.

9 Application and Implementation

NOTE

Information in the following applications sections is not part of the TI component specification, and TI does not warrant its accuracy or completeness. TI's customers are responsible for determining suitability of components for their purposes. Customers should validate and test their design implementation to confirm system functionality.

9.1 Application Information

The TMP43x devices require only a transistor connected between the DXP and DXN pins for remote temperature measurement. Tie the DXP pin to GND if the remote channel is not used and only the local temperature is measured. The SDA, ALERT, and THERM pins (and SCL, if driven by an open-drain output) require pullup resistors as part of the communication bus. TI recommends a 0.1- μ F power-supply decoupling capacitor for local bypassing. Figure 20 shows a typical configuration of the TMP431; see Figure 21 for a typical configuration of the TMP432.

9.2 Typical Application

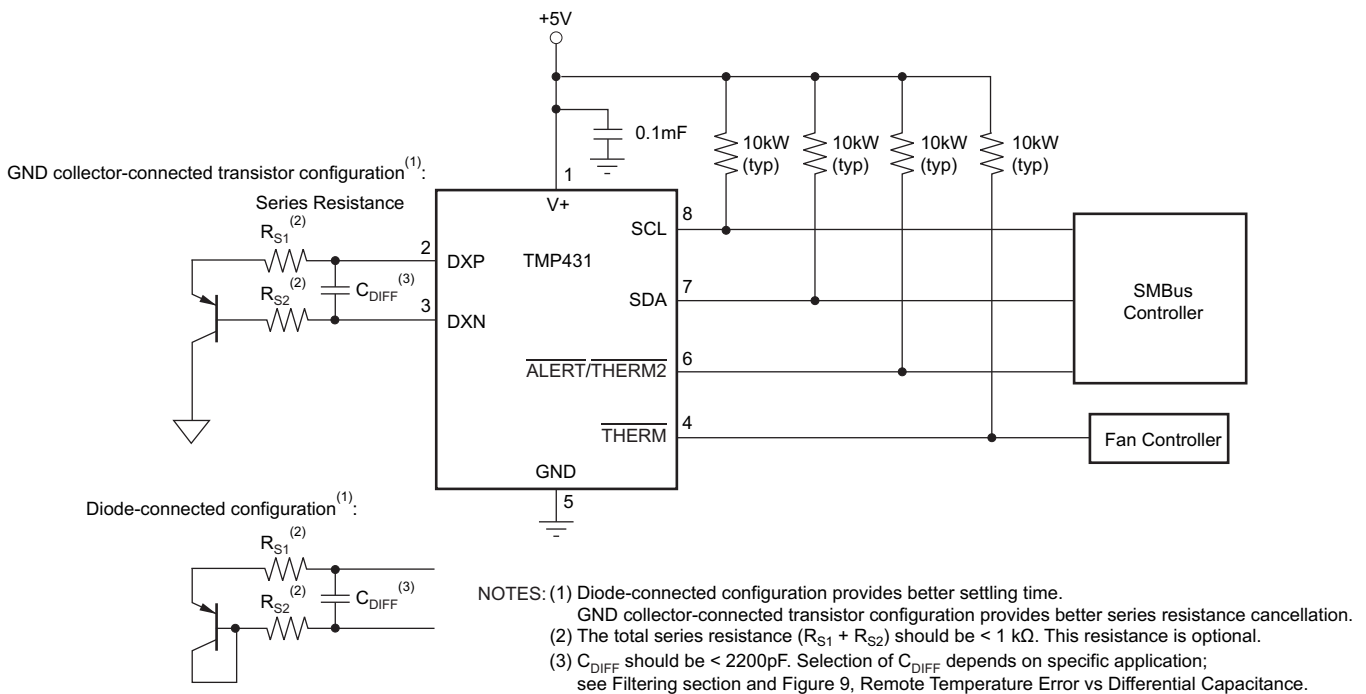

Figure 20. TMP431 Basic Connections

Typical Application (continued)

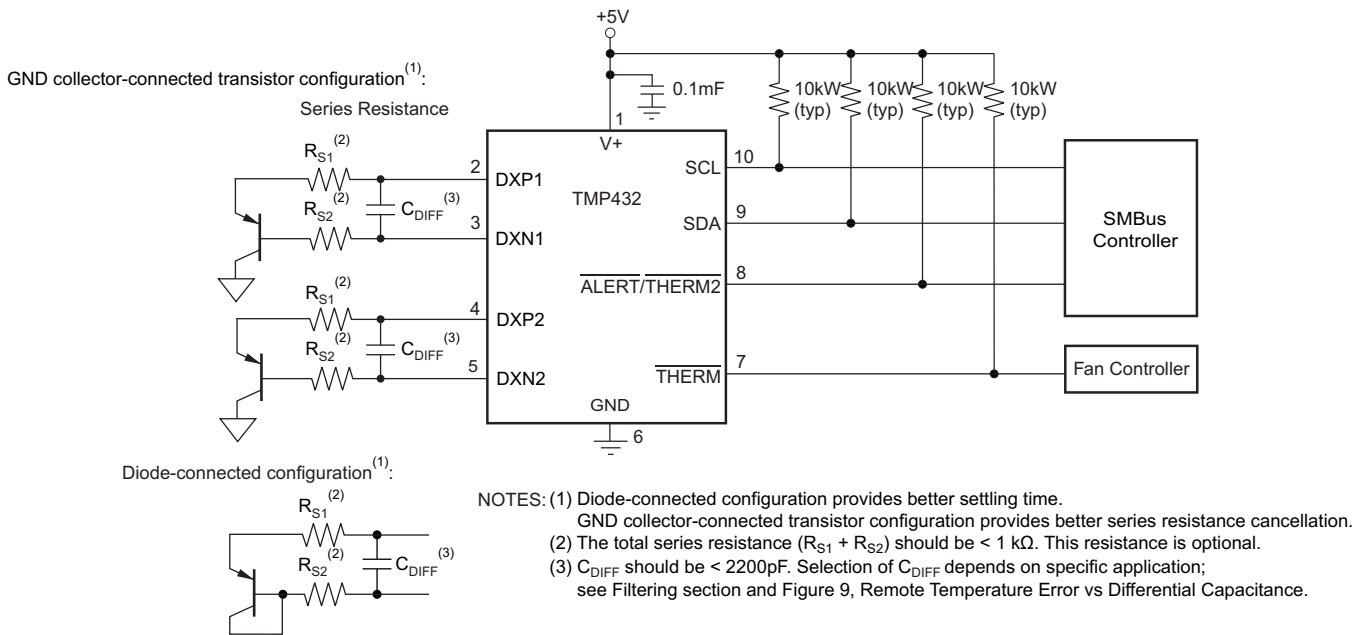

Figure 21. TMP432 Basic Connections

9.2.1 Design Requirements

The TMP43x are designed to be used with either discrete transistors or substrate transistors built into processor chips and ASICs. Either NPN- or PNP-type transistors can be used, as long as the base-emitter junction is used as the remote temperature sense. NPN transistors must be diode-connected. PNP transistors can either be transistor- or diode- connected (see Figure 20).

Errors in remote temperature sensor readings are typically the consequence of the ideality factor and current excitation used by the TMP43x versus the manufacturer-specified operating current for a given transistor. Some manufacturers specify a high-level and low-level current for the temperature-sensing substrate transistors. The TMP43x use $6\text{ }\mu\text{A}$ for I_{LOW} and $120\text{ }\mu\text{A}$ for I_{HIGH} . The TMP43x allow for different η -factor values; see [η-Factor Correction Register](#).

The ideality factor (η) is a measured characteristic of a remote temperature sensor diode as compared to an ideal diode. The ideality factor for the TMP43x is trimmed to be 1.008. For transistors whose ideality factor does not match the TMP43x, Equation 6 can be used to calculate the temperature error. Note that for the equation to be used correctly, actual temperature ($^{\circ}\text{C}$) must be converted to Kelvin (K).

$$T_{ERR} = \left(\frac{\eta - 1.008}{1.008} \right) \times [273.15 + T(^{\circ}\text{C})]$$

Where:

- η = Ideality factor of remote temperature sensor
 - $T(^{\circ}\text{C})$ = actual temperature
 - T_{ERR} = Error in TMP43x reading due to $\eta \neq 1.008$
 - Degree delta is the same for $^{\circ}\text{C}$ and K
- (6)

For $n = 1.004$ and $T(^{\circ}\text{C}) = 100^{\circ}\text{C}$:

$$T_{ERR} = \left(\frac{1.004 - 1.008}{1.008} \right) \times (273.15 + 100^{\circ}\text{C})$$

$$T_{ERR} = 1.48^{\circ}\text{C}$$

(7)

Typical Application (continued)

If a discrete transistor is used as the remote temperature sensor with the TMP43x, the best accuracy can be achieved by selecting the transistor according to the following criteria:

1. Base-emitter voltage > 0.25 V at 6 μ A, at the highest sensed temperature
2. Base-emitter voltage < 0.95 V at 120 μ A, at the lowest sensed temperature
3. Base resistance < 100 Ω
4. Tight control of V_{BE} characteristics indicated by small variations in h_{FE} (that is, 50 to 150)

Based on these criteria, two recommended small-signal transistors are the 2N3904 (NPN) or 2N3906 (PNP).

9.2.2 Detailed Design Procedure

The temperature measurement accuracy of the TMP43x depends on the remote and local temperature sensor being at the same temperature as the system point being monitored. Clearly, if the temperature sensor is not in good thermal contact with the part of the system being monitored, then there will be a delay in the response of the sensor to a temperature change in the system. For remote temperature sensing applications that use a substrate transistor (or a small, SOT23 transistor) placed close to the device being monitored, this delay is usually not a concern.

The local temperature sensor inside the TMP43x monitors the ambient air around the device. The thermal time constant for the TMP43x is approximately 2 s. This constant implies that if the ambient air changes quickly by 100°C, it would take the TMP43x about 10 seconds (that is, five thermal time constants) to settle to within 1°C of the final value. In most applications, the TMP43x package is in thermal contact with the printed circuit board (PCB), as well as subjected to forced airflow. The accuracy of the measured temperature directly depends on how accurately the PCB and forced airflow temperatures represent the temperature that the TMP43x is measuring. Additionally, the internal power dissipation of the TMP43x can cause the temperature to rise above the ambient or PCB temperature. The internal power dissipated as a result of exciting the remote temperature sensor is negligible because of the small currents used. For a 5.5-V supply and maximum conversion rate of eight conversions per second, the TMP43x dissipate 1.82 mW ($PD_{IQ} = 5.5 \text{ V} \times 330 \mu\text{A}$). If both the $\overline{\text{ALERT/THERM2}}$ and $\overline{\text{THERM}}$ pins are each sinking 1 mA, an additional 0.8 mW is dissipated ($PD_{OUT} = 1 \text{ mA} \times 0.4 \text{ V} + 1 \text{ mA} \times 0.4 \text{ V} = 0.8 \text{ mW}$). Total power dissipation is then 2.62 mW ($PD_{IQ} + PD_{OUT}$) and, with an θ_{JA} of 150°C/W, causes the junction temperature to rise approximately 0.393°C above the ambient.

9.2.3 Application Curve

Figure 22 shows the typical step response to a submerging of a sensor in an oil bath with temperature of 100°C.

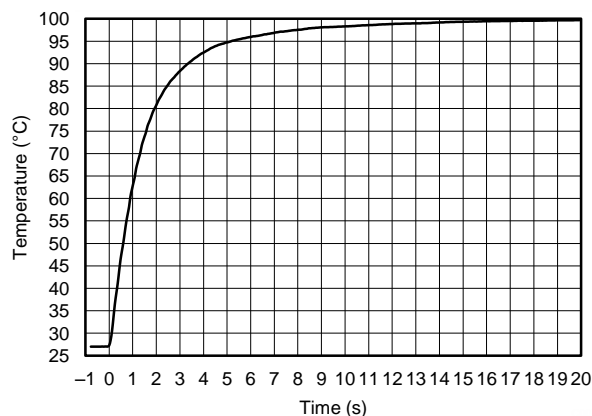

Figure 22. Temperature Step Response

10 Power Supply Recommendations

The TMP43x devices operates with a power supply range of 2.7 V to 5.5 V. The device is optimized for operation at 3.3-V supply but can measure temperature accurately in the full supply range.

TI recommends placing a power-supply bypass capacitor as close as possible to the supply and ground pins of the device. A typical value for this supply bypass capacitor is 0.1 μ F. Applications with noisy or high-impedance power supplies can require additional decoupling capacitors to reject power-supply noise.

11 Layout

11.1 Layout Guidelines

Remote temperature sensing on the TMP43x measures very small voltages using very low currents; therefore, noise at the IC inputs must be minimized. Most applications using the TMP43x have high digital content, with several clocks and logic level transitions creating a noisy environment. Layout must conform to the following guidelines:

1. Place the TMP43x as close to the remote junction sensor as possible.
2. Route the DXP and DXN traces next to each other and shield them from adjacent signals through the use of ground guard traces; see [Figure 24](#). If a multilayer PCB is used, bury these traces between ground or V_{DD} planes to shield them from extrinsic noise sources. TI recommends 5 mil (0.127 mm) PCB traces.
3. Minimize additional thermocouple junctions caused by copper-to-solder connections. If these junctions are used, make the same number and approximate locations of copper-to-solder connections in both the DXP and DXN connections to cancel any thermocouple effects.
4. Use a 0.1- μ F local bypass capacitor directly between the V+ and GND of the TMP43x. [Figure 25](#) illustrates the suggested bypass capacitor placement for the TMP43x. This capacitance includes any cable capacitance between the remote temperature sensor and TMP43x.
5. If the connection between the remote temperature sensor and the TMP43x is less than 8 inches (20.32 cm), use a twisted-wire pair connection. Beyond 8 inches, use a twisted, shielded pair with the shield grounded as close to the TMP43x as possible. Leave the remote sensor connection end of the shield wire open to avoid ground loops and 60-Hz pickup.
6. Thoroughly clean and remove all flux residue in and around the pins of the TMP43x to avoid temperature offset readings as a result of leakage paths between DXP or DXN and GND, or between DXP or DXN and V+.

11.2 Layout Examples

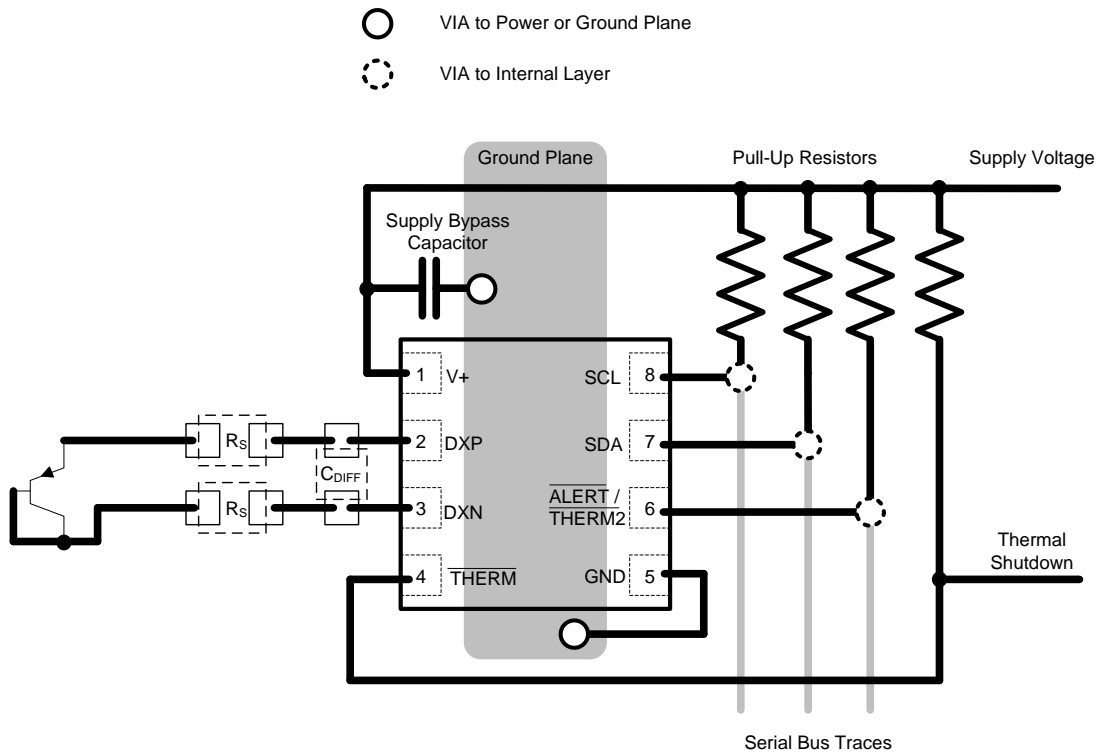
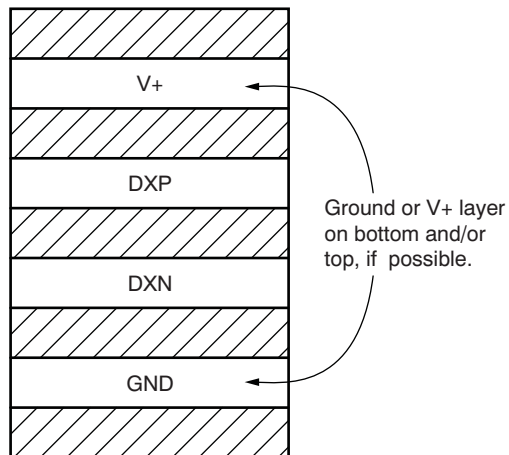

Figure 23. TMP431 Layout Example



Note: Use 5 mil (0.005 in, or 0.127 mm) traces with 5 mil (0.005 in, or 0.127 mm) spacing.

Figure 24. Example Signal Traces

Layout Examples (continued)

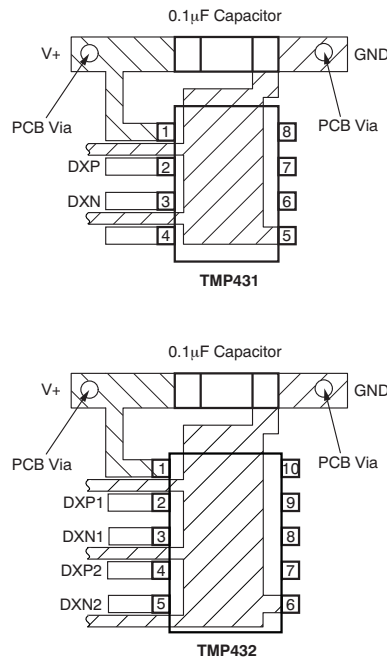

Figure 25. Suggested Bypass Capacitor Placement

12 Device and Documentation Support

12.1 Related Links

The table below lists quick access links. Categories include technical documents, support and community resources, tools and software, and quick access to sample or buy.

Table 16. Related Links

PARTS	PRODUCT FOLDER	SAMPLE & BUY	TECHNICAL DOCUMENTS	TOOLS & SOFTWARE	SUPPORT & COMMUNITY
TMP431	Click here	Click here	Click here	Click here	Click here
TMP432	Click here	Click here	Click here	Click here	Click here

12.2 Community Resources

The following links connect to TI community resources. Linked contents are provided "AS IS" by the respective contributors. They do not constitute TI specifications and do not necessarily reflect TI's views; see TI's [Terms of Use](#).

TI E2E™ Online Community *TI's Engineer-to-Engineer (E2E) Community*. Created to foster collaboration among engineers. At e2e.ti.com, you can ask questions, share knowledge, explore ideas and help solve problems with fellow engineers.

Design Support *TI's Design Support* Quickly find helpful E2E forums along with design support tools and contact information for technical support.

12.3 Trademarks

E2E is a trademark of Texas Instruments.
 DLP is a registered trademark of Texas Instruments.
 SMBus is a trademark of Intel Corporation.
 All other trademarks are the property of their respective owners.

12.4 Electrostatic Discharge Caution



These devices have limited built-in ESD protection. The leads should be shorted together or the device placed in conductive foam during storage or handling to prevent electrostatic damage to the MOS gates.

12.5 Glossary

[SLYZ022](#) — *TI Glossary*.

This glossary lists and explains terms, acronyms, and definitions.

13 Mechanical, Packaging, and Orderable Information

The following pages include mechanical, packaging, and orderable information. This information is the most current data available for the designated devices. This data is subject to change without notice and revision of this document. For browser-based versions of this data sheet, refer to the left-hand navigation.

PACKAGING INFORMATION

Orderable Device	Status (1)	Package Type	Package Drawing	Pins	Package Qty	Eco Plan (2)	Lead/Ball Finish (6)	MSL Peak Temp (3)	Op Temp (°C)	Device Marking (4/5)	Samples
TMP431ADGKR	ACTIVE	VSSOP	DGK	8	2500	Green (RoHS & no Sb/Br)	CU NIPDAUAG	Level-2-260C-1 YEAR	-40 to 125	DRTI	Samples
TMP431ADGKT	ACTIVE	VSSOP	DGK	8	250	Green (RoHS & no Sb/Br)	CU NIPDAUAG	Level-2-260C-1 YEAR	-40 to 125	DRTI	Samples
TMP431BDGKR	ACTIVE	VSSOP	DGK	8	2500	Green (RoHS & no Sb/Br)	CU NIPDAUAG	Level-2-260C-1 YEAR	-40 to 125	DRUI	Samples
TMP431BDGKT	ACTIVE	VSSOP	DGK	8	250	Green (RoHS & no Sb/Br)	CU NIPDAUAG	Level-2-260C-1 YEAR	-40 to 125	DRUI	Samples
TMP431CDGKR	ACTIVE	VSSOP	DGK	8	2500	Green (RoHS & no Sb/Br)	CU NIPDAU CU NIPDAUAG	Level-2-260C-1 YEAR	-40 to 125	DUEC	Samples
TMP431CDGKT	ACTIVE	VSSOP	DGK	8	250	Green (RoHS & no Sb/Br)	CU NIPDAU CU NIPDAUAG	Level-2-260C-1 YEAR	-40 to 125	DUEC	Samples
TMP431DDGKR	ACTIVE	VSSOP	DGK	8	2500	Green (RoHS & no Sb/Br)	CU NIPDAU	Level-2-260C-1 YEAR	-40 to 125	DUFC	Samples
TMP431DDGKT	ACTIVE	VSSOP	DGK	8	250	Green (RoHS & no Sb/Br)	CU NIPDAU	Level-2-260C-1 YEAR	-40 to 125	DUFC	Samples
TMP432ADGSR	ACTIVE	VSSOP	DGS	10	2500	Green (RoHS & no Sb/Br)	CU NIPDAU CU NIPDAUAG	Level-2-260C-1 YEAR	-40 to 125	DSCI	Samples
TMP432ADGST	ACTIVE	VSSOP	DGS	10	250	Green (RoHS & no Sb/Br)	CU NIPDAU CU NIPDAUAG	Level-2-260C-1 YEAR	-40 to 125	DSCI	Samples
TMP432BDGSR	ACTIVE	VSSOP	DGS	10	2500	Green (RoHS & no Sb/Br)	CU NIPDAU CU NIPDAUAG	Level-2-260C-1 YEAR	-40 to 125	DSDI	Samples
TMP432BDGST	ACTIVE	VSSOP	DGS	10	250	Green (RoHS & no Sb/Br)	CU NIPDAU CU NIPDAUAG	Level-2-260C-1 YEAR	-40 to 125	DSDI	Samples

(1) The marketing status values are defined as follows:

ACTIVE: Product device recommended for new designs.

LIFEBUY: TI has announced that the device will be discontinued, and a lifetime-buy period is in effect.

NRND: Not recommended for new designs. Device is in production to support existing customers, but TI does not recommend using this part in a new design.

PREVIEW: Device has been announced but is not in production. Samples may or may not be available.

OBSELETE: TI has discontinued the production of the device.

(2) Eco Plan - The planned eco-friendly classification: Pb-Free (RoHS), Pb-Free (RoHS Exempt), or Green (RoHS & no Sb/Br) - please check <http://www.ti.com/productcontent> for the latest availability information and additional product content details.

TBD: The Pb-Free/Green conversion plan has not been defined.

Pb-Free (RoHS): TI's terms "Lead-Free" or "Pb-Free" mean semiconductor products that are compatible with the current RoHS requirements for all 6 substances, including the requirement that lead not exceed 0.1% by weight in homogeneous materials. Where designed to be soldered at high temperatures, TI Pb-Free products are suitable for use in specified lead-free processes.

Pb-Free (RoHS Exempt): This component has a RoHS exemption for either 1) lead-based flip-chip solder bumps used between the die and package, or 2) lead-based die adhesive used between the die and leadframe. The component is otherwise considered Pb-Free (RoHS compatible) as defined above.

Green (RoHS & no Sb/Br): TI defines "Green" to mean Pb-Free (RoHS compatible), and free of Bromine (Br) and Antimony (Sb) based flame retardants (Br or Sb do not exceed 0.1% by weight in homogeneous material)

⁽³⁾ MSL, Peak Temp. - The Moisture Sensitivity Level rating according to the JEDEC industry standard classifications, and peak solder temperature.

⁽⁴⁾ There may be additional marking, which relates to the logo, the lot trace code information, or the environmental category on the device.

⁽⁵⁾ Multiple Device Markings will be inside parentheses. Only one Device Marking contained in parentheses and separated by a "~" will appear on a device. If a line is indented then it is a continuation of the previous line and the two combined represent the entire Device Marking for that device.

⁽⁶⁾ Lead/Ball Finish - Orderable Devices may have multiple material finish options. Finish options are separated by a vertical ruled line. Lead/Ball Finish values may wrap to two lines if the finish value exceeds the maximum column width.

Important Information and Disclaimer:The information provided on this page represents TI's knowledge and belief as of the date that it is provided. TI bases its knowledge and belief on information provided by third parties, and makes no representation or warranty as to the accuracy of such information. Efforts are underway to better integrate information from third parties. TI has taken and continues to take reasonable steps to provide representative and accurate information but may not have conducted destructive testing or chemical analysis on incoming materials and chemicals. TI and TI suppliers consider certain information to be proprietary, and thus CAS numbers and other limited information may not be available for release.

In no event shall TI's liability arising out of such information exceed the total purchase price of the TI part(s) at issue in this document sold by TI to Customer on an annual basis.

TAPE AND REEL INFORMATION



QUADRANT ASSIGNMENTS FOR PIN 1 ORIENTATION IN TAPE



*All dimensions are nominal

Device	Package Type	Package Drawing	Pins	SPQ	Reel Diameter (mm)	Reel Width W1 (mm)	A0 (mm)	B0 (mm)	K0 (mm)	P1 (mm)	W (mm)	Pin1 Quadrant
TMP431ADGKR	VSSOP	DGK	8	2500	330.0	12.4	5.3	3.4	1.4	8.0	12.0	Q1
TMP431ADGKT	VSSOP	DGK	8	250	330.0	12.4	5.3	3.4	1.4	8.0	12.0	Q1
TMP431BDGKR	VSSOP	DGK	8	2500	330.0	12.4	5.3	3.4	1.4	8.0	12.0	Q1
TMP431BDGKT	VSSOP	DGK	8	250	330.0	12.4	5.3	3.4	1.4	8.0	12.0	Q1
TMP431CDGKR	VSSOP	DGK	8	2500	330.0	12.4	5.3	3.4	1.4	8.0	12.0	Q1
TMP431CDGKT	VSSOP	DGK	8	250	330.0	12.4	5.3	3.4	1.4	8.0	12.0	Q1
TMP431CDGKT	VSSOP	DGK	8	250	177.8	12.4	5.3	3.4	1.4	8.0	12.0	Q1
TMP431DDGKR	VSSOP	DGK	8	2500	330.0	12.4	5.3	3.4	1.4	8.0	12.0	Q1
TMP431DDGKT	VSSOP	DGK	8	250	177.8	12.4	5.3	3.4	1.4	8.0	12.0	Q1
TMP432ADGSR	VSSOP	DGS	10	2500	330.0	12.4	5.3	3.4	1.4	8.0	12.0	Q1
TMP432ADGSR	VSSOP	DGS	10	2500	330.0	12.4	5.3	3.4	1.4	8.0	12.0	Q1
TMP432ADGST	VSSOP	DGS	10	250	330.0	12.4	5.3	3.4	1.4	8.0	12.0	Q1
TMP432ADGST	VSSOP	DGS	10	250	330.0	12.4	5.3	3.4	1.4	8.0	12.0	Q1
TMP432BDGSR	VSSOP	DGS	10	2500	330.0	12.4	5.3	3.4	1.4	8.0	12.0	Q1
TMP432BDGSR	VSSOP	DGS	10	2500	330.0	12.4	5.3	3.4	1.4	8.0	12.0	Q1
TMP432BDGST	VSSOP	DGS	10	250	330.0	12.4	5.3	3.4	1.4	8.0	12.0	Q1
TMP432BDGST	VSSOP	DGS	10	250	177.8	12.4	5.3	3.4	1.4	8.0	12.0	Q1

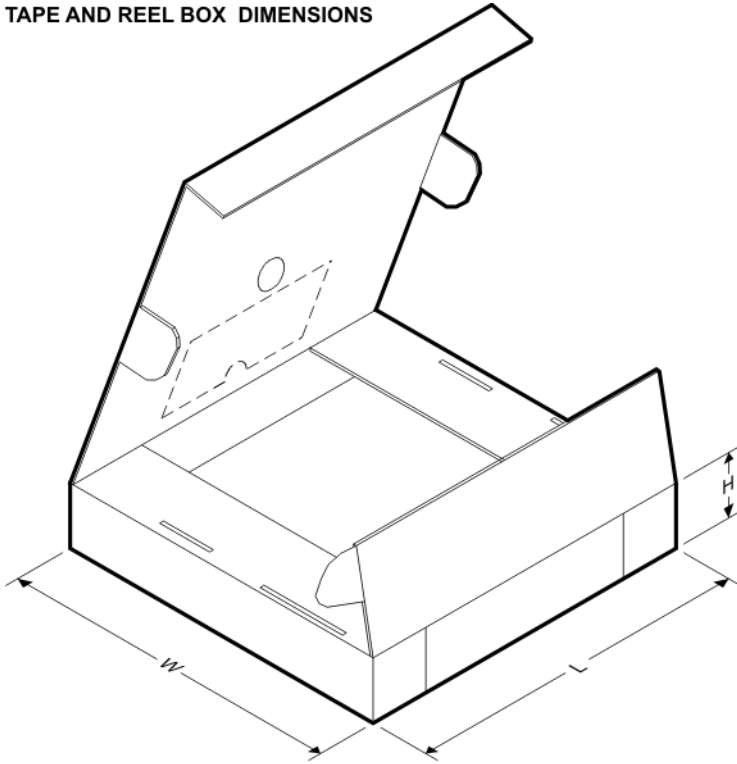
TAPE AND REEL BOX DIMENSIONS

*All dimensions are nominal

Device	Package Type	Package Drawing	Pins	SPQ	Length (mm)	Width (mm)	Height (mm)
TMP431ADGKR	VSSOP	DGK	8	2500	366.0	364.0	50.0
TMP431ADGKT	VSSOP	DGK	8	250	366.0	364.0	50.0
TMP431BDGKR	VSSOP	DGK	8	2500	366.0	364.0	50.0
TMP431BDGKT	VSSOP	DGK	8	250	366.0	364.0	50.0
TMP431CDGKR	VSSOP	DGK	8	2500	346.0	346.0	41.0
TMP431CDGKR	VSSOP	DGK	8	2500	366.0	364.0	50.0
TMP431CDGKT	VSSOP	DGK	8	250	366.0	364.0	50.0
TMP431CDGKT	VSSOP	DGK	8	250	223.0	270.0	35.0
TMP431DDGKR	VSSOP	DGK	8	2500	346.0	346.0	29.0
TMP431DDGKT	VSSOP	DGK	8	250	223.0	270.0	35.0
TMP432ADGSR	VSSOP	DGS	10	2500	346.0	346.0	41.0
TMP432ADGSR	VSSOP	DGS	10	2500	366.0	364.0	50.0
TMP432ADGST	VSSOP	DGS	10	250	358.0	335.0	35.0
TMP432ADGST	VSSOP	DGS	10	250	366.0	364.0	50.0
TMP432BDGSR	VSSOP	DGS	10	2500	346.0	346.0	41.0
TMP432BDGSR	VSSOP	DGS	10	2500	366.0	364.0	50.0
TMP432BDGST	VSSOP	DGS	10	250	366.0	364.0	50.0
TMP432BDGST	VSSOP	DGS	10	250	223.0	270.0	35.0

DGS0010A



PACKAGE OUTLINE

VSSOP - 1.1 mm max height

SMALL OUTLINE PACKAGE



4221984/A 05/2015

NOTES:

1. All linear dimensions are in millimeters. Any dimensions in parenthesis are for reference only. Dimensioning and tolerancing per ASME Y14.5M.
2. This drawing is subject to change without notice.
3. This dimension does not include mold flash, protrusions, or gate burrs. Mold flash, protrusions, or gate burrs shall not exceed 0.15 mm per side.
4. This dimension does not include interlead flash. Interlead flash shall not exceed 0.25 mm per side.
5. Reference JEDEC registration MO-187, variation BA.

EXAMPLE BOARD LAYOUT

DGS0010A

VSSOP - 1.1 mm max height

SMALL OUTLINE PACKAGE

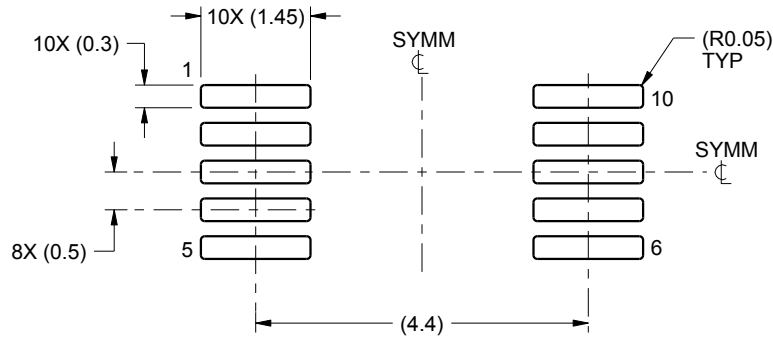

LAND PATTERN EXAMPLE
SCALE:10X

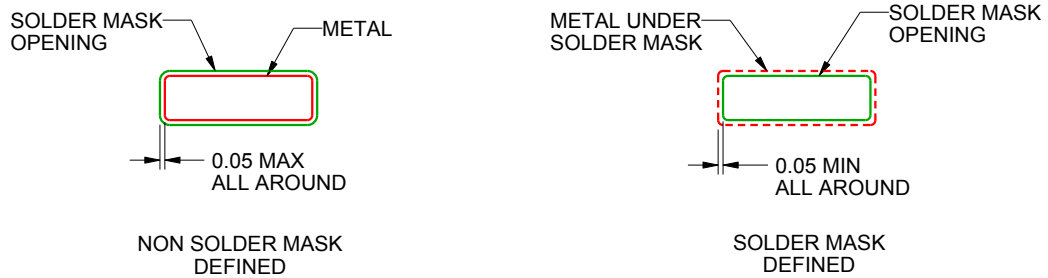

SOLDER MASK DETAILS
NOT TO SCALE

4221984/A 05/2015

NOTES: (continued)

- 6. Publication IPC-7351 may have alternate designs.
- 7. Solder mask tolerances between and around signal pads can vary based on board fabrication site.

EXAMPLE STENCIL DESIGN

DGS0010A

VSSOP - 1.1 mm max height

SMALL OUTLINE PACKAGE



SOLDER PASTE EXAMPLE
BASED ON 0.125 mm THICK STENCIL
SCALE:10X

4221984/A 05/2015

NOTES: (continued)

8. Laser cutting apertures with trapezoidal walls and rounded corners may offer better paste release. IPC-7525 may have alternate design recommendations.
9. Board assembly site may have different recommendations for stencil design.

DGK (S-PDSO-G8)

PLASTIC SMALL-OUTLINE PACKAGE

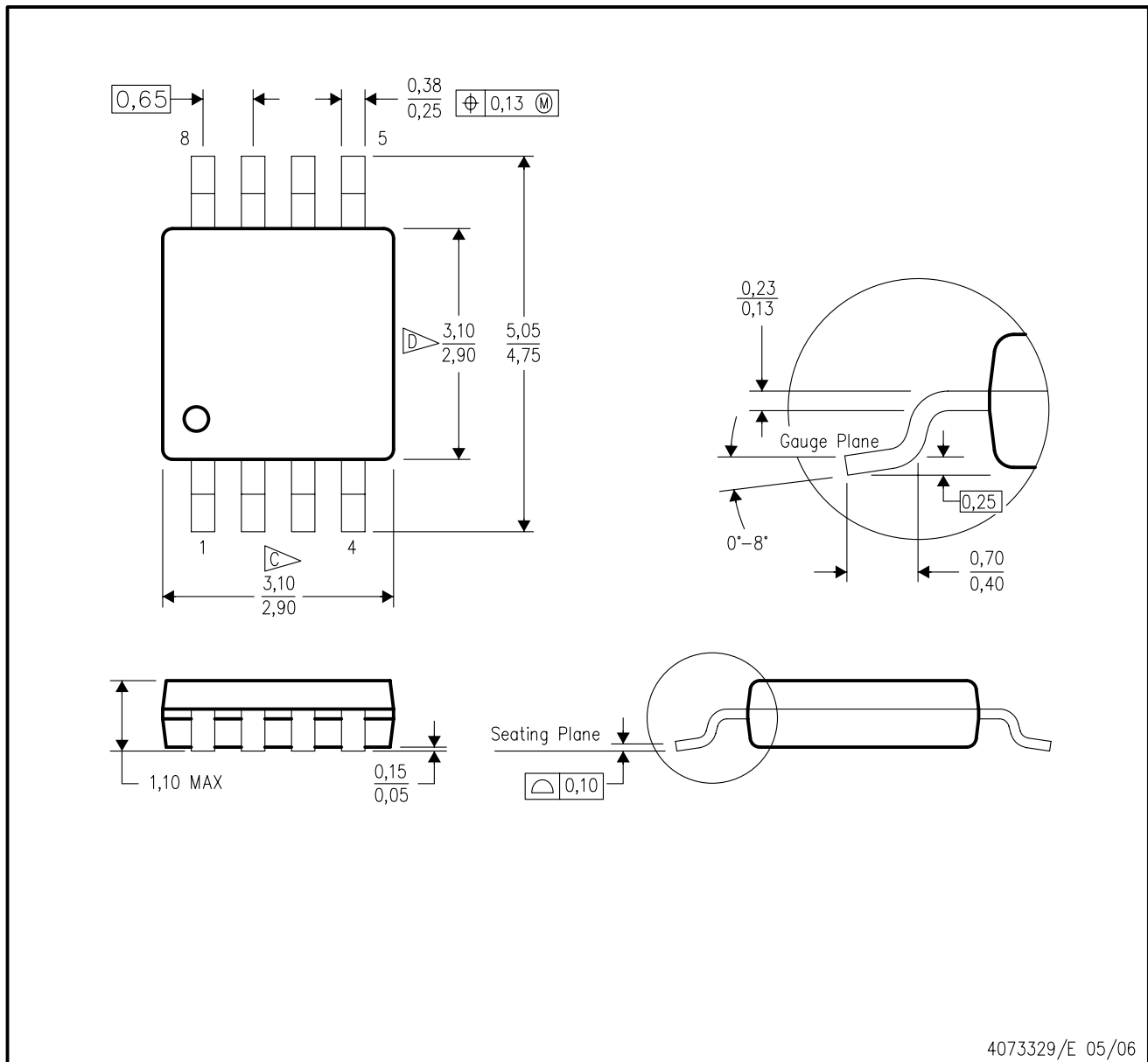

- NOTES:
- A. All linear dimensions are in millimeters.
 - B. This drawing is subject to change without notice.
 - C. Body length does not include mold flash, protrusions, or gate burrs. Mold flash, protrusions, or gate burrs shall not exceed 0.15 per end.
 - D. Body width does not include interlead flash. Interlead flash shall not exceed 0.50 per side.
 - E. Falls within JEDEC MO-187 variation AA, except interlead flash.



- NOTES:
- A. All linear dimensions are in millimeters.
 - B. This drawing is subject to change without notice.
 - C. Publication IPC-7351 is recommended for alternate designs.
 - D. Laser cutting apertures with trapezoidal walls and also rounding corners will offer better paste release. Customers should contact their board assembly site for stencil design recommendations. Refer to IPC-7525 for other stencil recommendations.
 - E. Customers should contact their board fabrication site for solder mask tolerances between and around signal pads.

IMPORTANT NOTICE AND DISCLAIMER

TI PROVIDES TECHNICAL AND RELIABILITY DATA (INCLUDING DATASHEETS), DESIGN RESOURCES (INCLUDING REFERENCE DESIGNS), APPLICATION OR OTHER DESIGN ADVICE, WEB TOOLS, SAFETY INFORMATION, AND OTHER RESOURCES "AS IS" AND WITH ALL FAULTS, AND DISCLAIMS ALL WARRANTIES, EXPRESS AND IMPLIED, INCLUDING WITHOUT LIMITATION ANY IMPLIED WARRANTIES OF MERCHANTABILITY, FITNESS FOR A PARTICULAR PURPOSE OR NON-INFRINGEMENT OF THIRD PARTY INTELLECTUAL PROPERTY RIGHTS.

These resources are intended for skilled developers designing with TI products. You are solely responsible for (1) selecting the appropriate TI products for your application, (2) designing, validating and testing your application, and (3) ensuring your application meets applicable standards, and any other safety, security, or other requirements. These resources are subject to change without notice. TI grants you permission to use these resources only for development of an application that uses the TI products described in the resource. Other reproduction and display of these resources is prohibited. No license is granted to any other TI intellectual property right or to any third party intellectual property right. TI disclaims responsibility for, and you will fully indemnify TI and its representatives against, any claims, damages, costs, losses, and liabilities arising out of your use of these resources.

TI's products are provided subject to TI's Terms of Sale (www.ti.com/legal/termsofsale.html) or other applicable terms available either on ti.com or provided in conjunction with such TI products. TI's provision of these resources does not expand or otherwise alter TI's applicable warranties or warranty disclaimers for TI products.

Mailing Address: Texas Instruments, Post Office Box 655303, Dallas, Texas 75265
Copyright © 2019, Texas Instruments Incorporated

Looking for pricing, stock, or lifecycle information?

Click below to explore more details on WIN SOURCE:

 [View TMP431ADGKR on WIN SOURCE](#)

 [Texas Instruments](#) Information

Optimize Your Supply Chain with WIN SOURCE Solutions

-  Global Sourcing Solution
-  Obsolete Management
-  Cost Control Management
-  Shortage Management
-  Alternative Solution
-  Excess Inventory Management