



**THE DATASHEET OF  
TPS1120DR**



# TPS1120, TPS1120Y DUAL P-CHANNEL ENHANCEMENT-MODE MOSFETS

SLVS080A – MARCH 1994 – REVISED AUGUST 1995

- Low  $r_{DS(on)}$  . . . 0.18  $\Omega$  at  $V_{GS} = -10$  V
- 3-V Compatible
- Requires No External  $V_{CC}$
- TTL and CMOS Compatible Inputs
- $V_{GS(th)} = -1.5$  V Max
- ESD Protection Up to 2 kV per MIL-STD-883C, Method 3015

D PACKAGE  
(TOP VIEW)

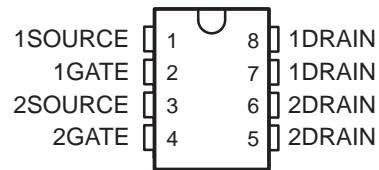

## description

The TPS1120 incorporates two independent p-channel enhancement-mode MOSFETs that have been optimized, by means of the Texas Instruments LinBiCMOS™ process, for 3-V or 5-V power distribution in battery-powered systems. With a maximum  $V_{GS(th)}$  of  $-1.5$  V and an  $I_{DSS}$  of only  $0.5 \mu A$ , the TPS1120 is the ideal high-side switch for low-voltage portable battery-management systems, where maximizing battery life is a primary concern. Because portable equipment is potentially subject to electrostatic discharge (ESD), the MOSFETs have built-in circuitry for 2-kV ESD protection. End equipment for the TPS1120 includes notebook computers, personal digital assistants (PDAs), cellular telephones, bar-code scanners, and PCMCIA cards. For existing designs, the TPS1120D has a pinout common with other p-channel MOSFETs in small-outline integrated circuit SOIC packages.

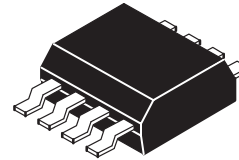

The TPS1120 is characterized for an operating junction temperature range,  $T_J$ , from  $-40^\circ C$  to  $150^\circ C$ .

AVAILABLE OPTIONS

$T_J$	PACKAGED DEVICES†	CHIP FORM (Y)
	SMALL OUTLINE (D)	
$-40^\circ C$ to $150^\circ C$	TPS1120D	TPS1120Y

† The D package is available taped and reeled. Add an R suffix to device type (e.g., TPS1120DR). The chip form is tested at  $25^\circ C$ .



Caution. This device contains circuits to protect its inputs and outputs against damage due to high static voltages or electrostatic fields. These circuits have been qualified to protect this device against electrostatic discharges (ESD) of up to 2 kV according to MIL-STD-883C, Method 3015; however, it is advised that precautions be taken to avoid application of any voltage higher than maximum-rated voltages to these high-impedance circuits.

LinBiCMOS is a trademark of Texas Instruments Incorporated.

PRODUCTION DATA information is current as of publication date. Products conform to specifications per the terms of Texas Instruments standard warranty. Production processing does not necessarily include testing of all parameters.

 **TEXAS  
INSTRUMENTS**

POST OFFICE BOX 655303 • DALLAS, TEXAS 75265

Copyright © 1995, Texas Instruments Incorporated

# TPS1120, TPS1120Y DUAL P-CHANNEL ENHANCEMENT-MODE MOSFETS

SLVS080A – MARCH 1994 – REVISED AUGUST 1995

## schematic

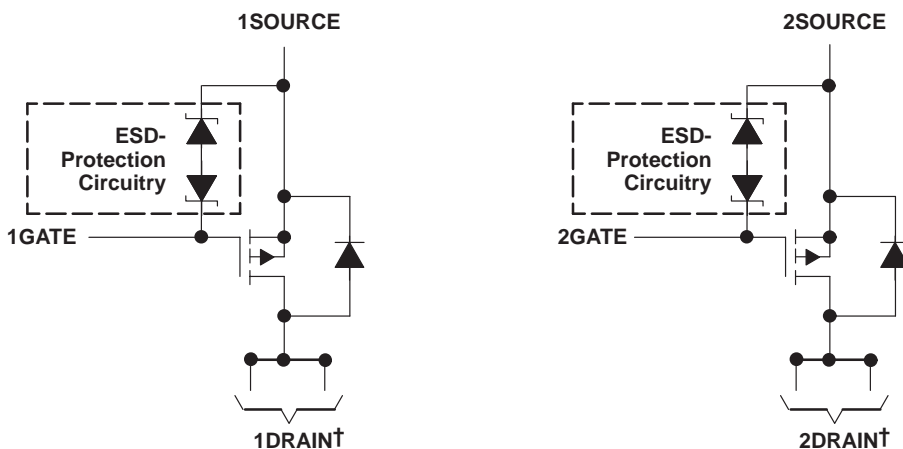

† For all applications, both drain pins for each device should be connected.

## TPS1120Y chip information

This chip, when properly assembled, displays characteristics similar to the TPS1120C. Thermal compression or ultrasonic bonding may be used on the doped aluminum bonding pads. The chip may be mounted with conductive epoxy or a gold-silicon preform.

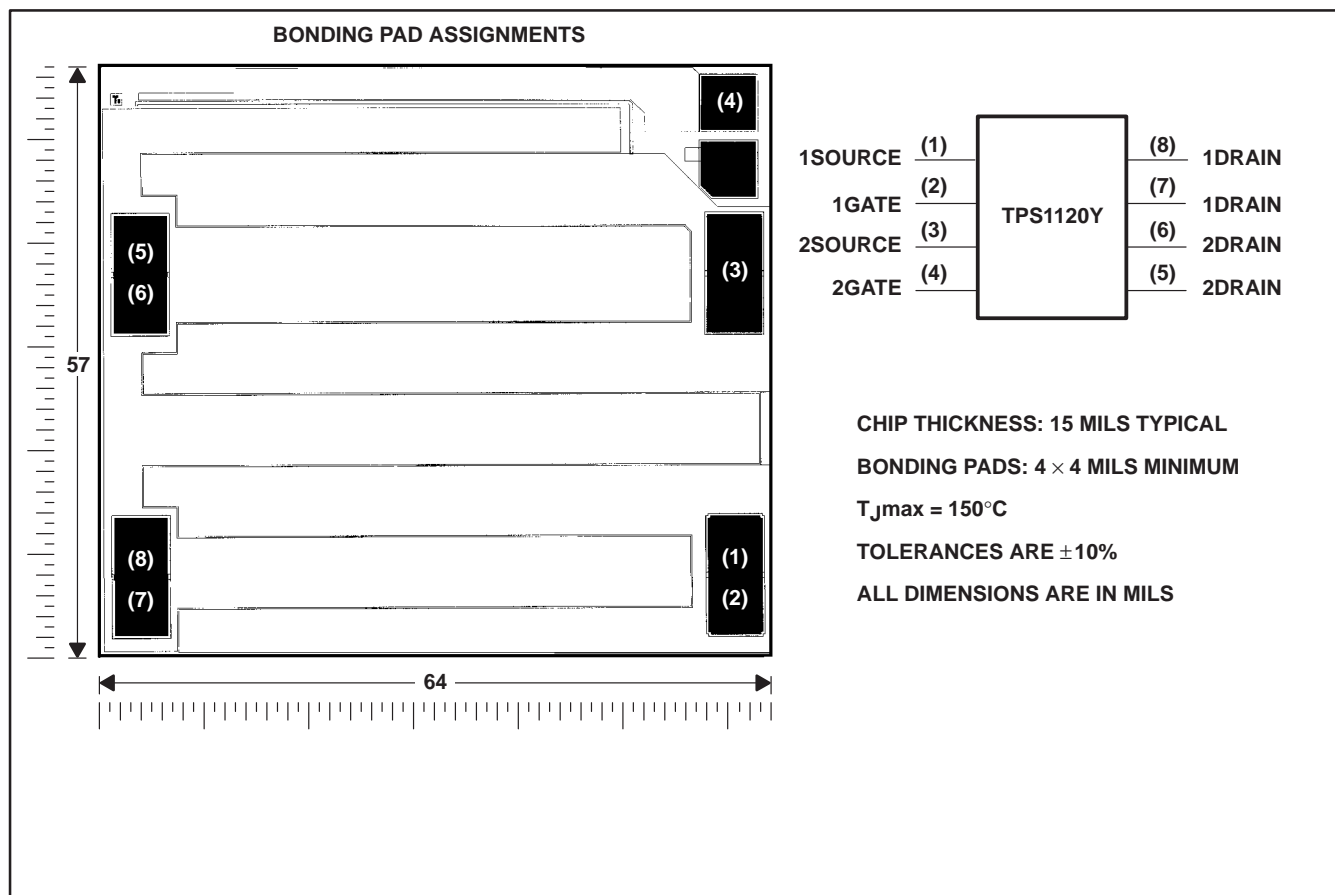

# TPS1120, TPS1120Y DUAL P-CHANNEL ENHANCEMENT-MODE MOSFETS

SLVS080A – MARCH 1994 – REVISED AUGUST 1995

## absolute maximum ratings over operating free-air temperature (unless otherwise noted)<sup>†</sup>

			UNIT
Drain-to-source voltage, $V_{DS}$		-15	V
Gate-to-source voltage, $V_{GS}$		2 or -15	V
Continuous drain current, each device ( $T_J = 150^\circ\text{C}$ ), $I_D$	$V_{GS} = -2.7\text{ V}$	$T_A = 25^\circ\text{C}$	$\pm 0.39$
		$T_A = 125^\circ\text{C}$	$\pm 0.21$
	$V_{GS} = -3\text{ V}$	$T_A = 25^\circ\text{C}$	$\pm 0.5$
		$T_A = 125^\circ\text{C}$	$\pm 0.25$
	$V_{GS} = -4.5\text{ V}$	$T_A = 25^\circ\text{C}$	$\pm 0.74$
		$T_A = 125^\circ\text{C}$	$\pm 0.34$
$V_{GS} = -10\text{ V}$	$T_A = 25^\circ\text{C}$	$\pm 1.17$	
	$T_A = 125^\circ\text{C}$	$\pm 0.53$	
Pulse drain current, $I_D$		$T_A = 25^\circ\text{C}$	$\pm 7$
Continuous source current (diode conduction), $I_S$		$T_A = 25^\circ\text{C}$	-1
Continuous total power dissipation		See Dissipation Rating Table	
Storage temperature range, $T_{stg}$		-55 to 150	$^\circ\text{C}$
Operating junction temperature range, $T_J$		-40 to 150	$^\circ\text{C}$
Operating free-air temperature range, $T_A$		-40 to 125	$^\circ\text{C}$
Lead temperature 1,6 mm (1/16 inch) from case for 10 seconds		260	$^\circ\text{C}$

<sup>†</sup> Stresses beyond those listed under "absolute maximum ratings" may cause permanent damage to the device. These are stress ratings only, and functional operation of the device at these or any other conditions beyond those indicated under "recommended operating conditions" is not implied. Exposure to absolute-maximum-rated conditions for extended periods may affect device reliability.

**DISSIPATION RATING TABLE**

PACKAGE	$T_A \leq 25^\circ\text{C}$ POWER RATING	DERATING FACTOR <sup>‡</sup> ABOVE $T_A = 25^\circ\text{C}$	$T_A = 70^\circ\text{C}$ POWER RATING	$T_A = 85^\circ\text{C}$ POWER RATING	$T_A = 125^\circ\text{C}$ POWER RATING
D	840 mW	6.71 mW/ $^\circ\text{C}$	538 mW	437 mW	169 mW

<sup>‡</sup> Maximum values are calculated using a derating factor based on  $R_{\theta JA} = 149^\circ\text{C}/\text{W}$  for the package. These devices are mounted on an FR4 board with no special thermal considerations.

# TPS1120, TPS1120Y

## DUAL P-CHANNEL ENHANCEMENT-MODE MOSFETS

SLVS080A – MARCH 1994 – REVISED AUGUST 1995

### electrical characteristics at $T_J = 25^\circ\text{C}$ (unless otherwise noted)

#### static

PARAMETER	TEST CONDITIONS	TPS1120			UNIT
		MIN	TYP	MAX	
$V_{GS(th)}$ Gate-to-source threshold voltage	$V_{DS} = V_{GS}$ , $I_D = -250 \mu\text{A}$	-1	-1.25	-1.50	V
$V_{SD}$ Source-to-drain voltage (diode forward voltage) <sup>†</sup>	$I_S = -1 \text{ A}$ , $V_{GS} = 0 \text{ V}$	-0.9			V
$I_{GSS}$ Reverse gate current, drain short circuited to source	$V_{DS} = 0 \text{ V}$ , $V_{GS} = -12 \text{ V}$	±100			nA
$I_{DSS}$ Zero-gate-voltage drain current	$V_{DS} = -12 \text{ V}$ , $V_{GS} = 0 \text{ V}$	$T_J = 25^\circ\text{C}$		-0.5	$\mu\text{A}$
		$T_J = 125^\circ\text{C}$		-10	
$r_{DS(on)}$ Static drain-to-source on-state resistance <sup>†</sup>	$V_{GS} = -10 \text{ V}$	$I_D = -1.5 \text{ A}$	180		m $\Omega$
	$V_{GS} = -4.5 \text{ V}$	$I_D = -0.5 \text{ A}$	291 400		
	$V_{GS} = -3 \text{ V}$	$I_D = -0.2 \text{ A}$	476 700		
	$V_{GS} = -2.7 \text{ V}$		606 850		
$g_{fs}$ Forward transconductance <sup>†</sup>	$V_{DS} = -10 \text{ V}$ , $I_D = -2 \text{ A}$	2.5			S

<sup>†</sup> Pulse test: pulse width  $\leq 300 \mu\text{s}$ , duty cycle  $\leq 2\%$

#### static

PARAMETER	TEST CONDITIONS	TPS1120Y			UNIT
		MIN	TYP	MAX	
$V_{GS(th)}$ Gate-to-source threshold voltage	$V_{DS} = V_{GS}$ , $I_D = -250 \mu\text{A}$	-1.25			V
$V_{SD}$ Source-to-drain voltage (diode forward voltage) <sup>†</sup>	$I_S = -1 \text{ A}$ , $V_{GS} = 0 \text{ V}$	-0.9			V
$r_{DS(on)}$ Static drain-to-source on-state resistance <sup>†</sup>	$V_{GS} = -10 \text{ V}$	$I_D = -1.5 \text{ A}$	180		m $\Omega$
	$V_{GS} = -4.5 \text{ V}$	$I_D = -0.5 \text{ A}$	291		
	$V_{GS} = -3 \text{ V}$	$I_D = -0.2 \text{ A}$	476		
	$V_{GS} = -2.7 \text{ V}$		606		
$g_{fs}$ Forward transconductance <sup>†</sup>	$V_{DS} = -10 \text{ V}$ , $I_D = -2 \text{ A}$	2.5			S

<sup>†</sup> Pulse test: pulse width  $\leq 300 \mu\text{s}$ , duty cycle  $\leq 2\%$

#### dynamic

PARAMETER	TEST CONDITIONS	TPS1120, TPS1120Y			UNIT
		MIN	TYP	MAX	
$Q_g$ Total gate charge	$V_{DS} = -10 \text{ V}$ , $V_{GS} = -10 \text{ V}$ , $I_D = -1 \text{ A}$	5.45			nC
$Q_{gs}$ Gate-to-source charge		0.87			
$Q_{gd}$ Gate-to-drain charge		1.4			
$t_{d(on)}$ Turn-on delay time	$V_{DD} = -10 \text{ V}$ , $R_L = 10 \Omega$ , $R_G = 6 \Omega$ , See Figures 1 and 2 $I_D = -1 \text{ A}$ ,	4.5			ns
$t_{d(off)}$ Turn-off delay time		13			ns
$t_r$ Rise time		10			ns
$t_f$ Fall time		2			
$t_{rr(SD)}$ Source-to-drain reverse recovery time		$I_F = 5.3 \text{ A}$ , $di/dt = 100 \text{ A}/\mu\text{s}$	16		



PARAMETER MEASUREMENT INFORMATION

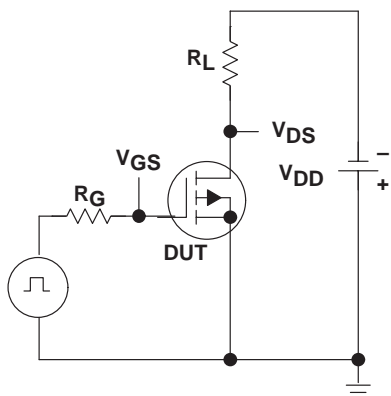

Figure 1. Switching-Time Test Circuit

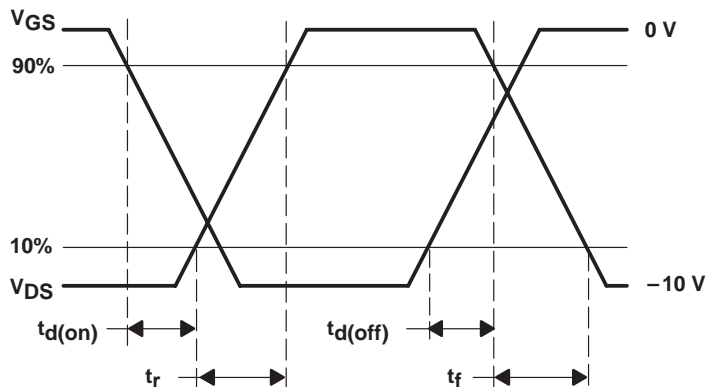

Figure 2. Switching-Time Waveforms

# TPS1120, TPS1120Y DUAL P-CHANNEL ENHANCEMENT-MODE MOSFETS

SLVS080A – MARCH 1994 – REVISED AUGUST 1995

## TYPICAL CHARACTERISTICS†

Table of Graphs

		FIGURE
Drain current	vs Drain-to-source voltage	3
Drain current	vs Gate-to-source voltage	4
Static drain-to-source on-state resistance	vs Drain current	5
Capacitance	vs Drain-to-source voltage	6
Static drain-to-source on-state resistance (normalized)	vs Junction temperature	7
Source-to-drain diode current	vs Source-to-drain voltage	8
Static drain-to-source on-state resistance	vs Gate-to-source voltage	9
Gate-to-source threshold voltage	vs Junction temperature	10
Gate-to-source voltage	vs Gate charge	11

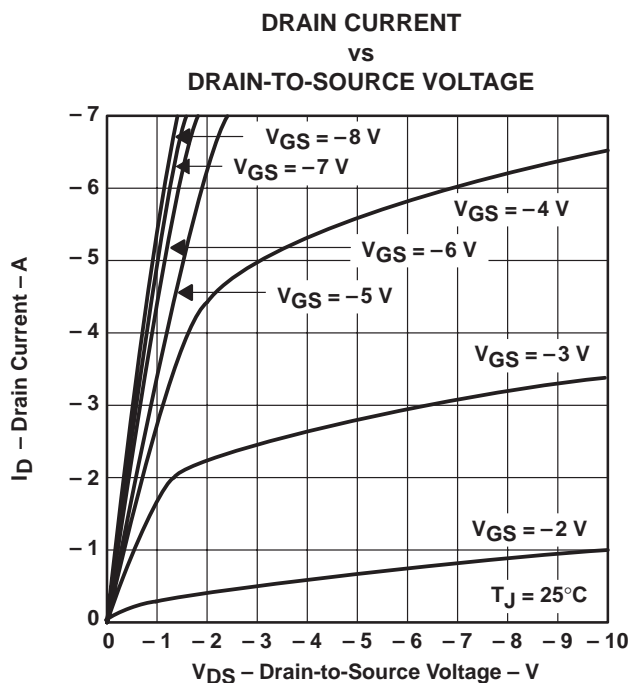

Figure 3

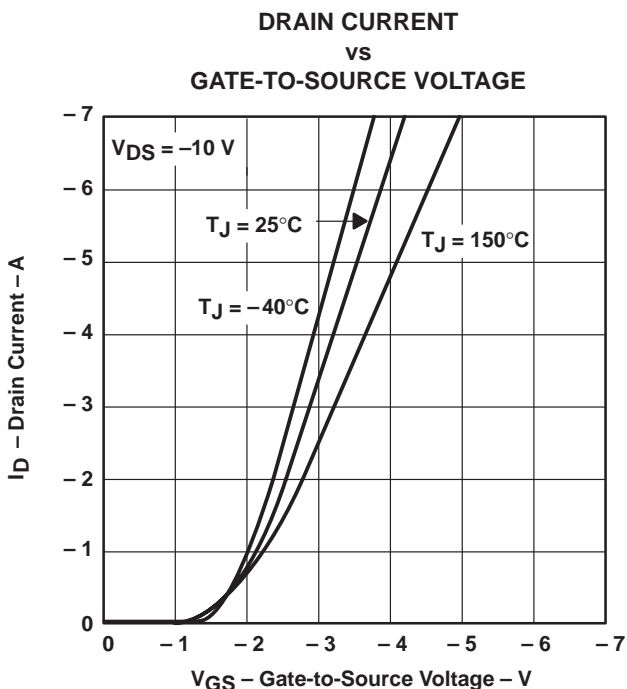

Figure 4

† All characteristics data applies for each independent MOSFET incorporated on the TPS1120.

TYPICAL CHARACTERISTICS

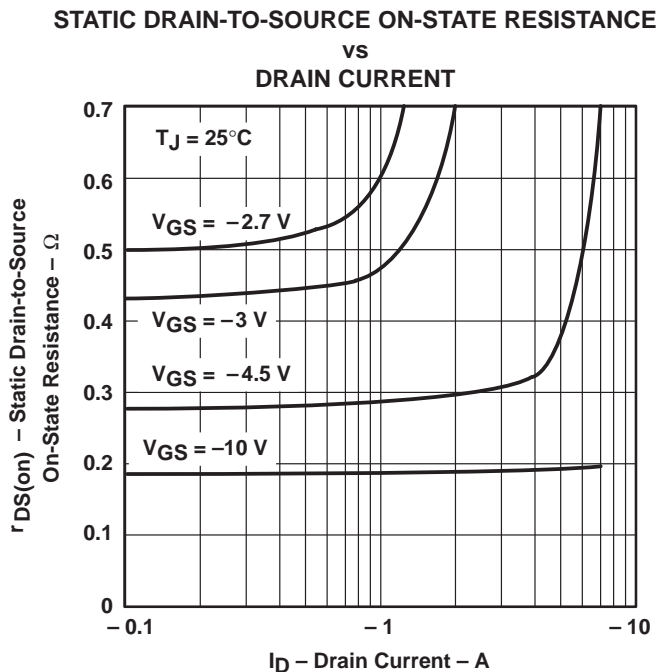
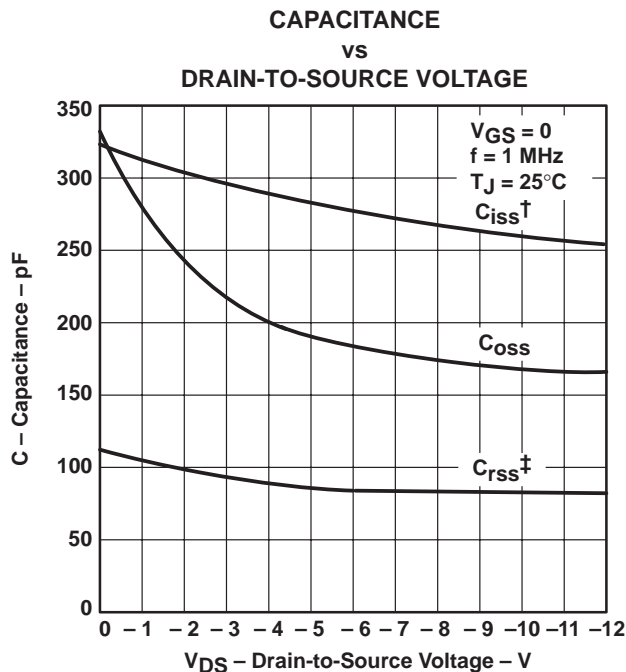

Figure 5



$$\dagger C_{iss} = C_{gs} + C_{gd}, C_{ds(\text{shorted})}$$

$$\ddagger C_{rss} = C_{gd}, C_{oss} = C_{ds} + \frac{C_{gs} C_{gd}}{C_{gs} + C_{gd}} \approx C_{ds} + C_{gd}$$

Figure 6

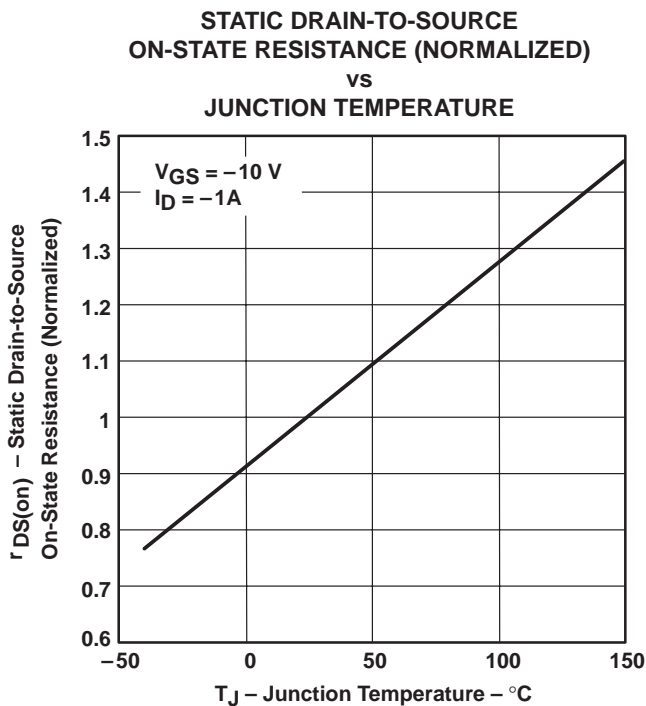

Figure 7

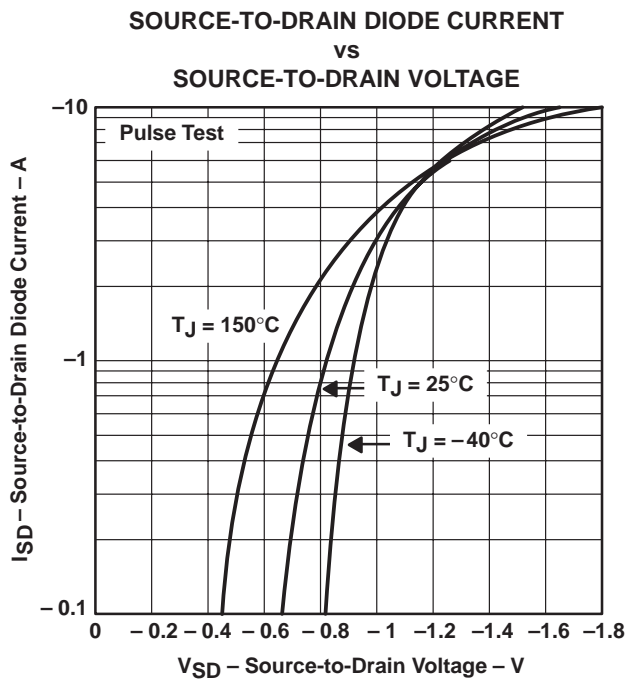

Figure 8

# TPS1120, TPS1120Y DUAL P-CHANNEL ENHANCEMENT-MODE MOSFETS

SLVS080A – MARCH 1994 – REVISED AUGUST 1995

## TYPICAL CHARACTERISTICS

STATIC DRAIN-TO-SOURCE ON-STATE RESISTANCE  
vs  
GATE-TO-SOURCE VOLTAGE

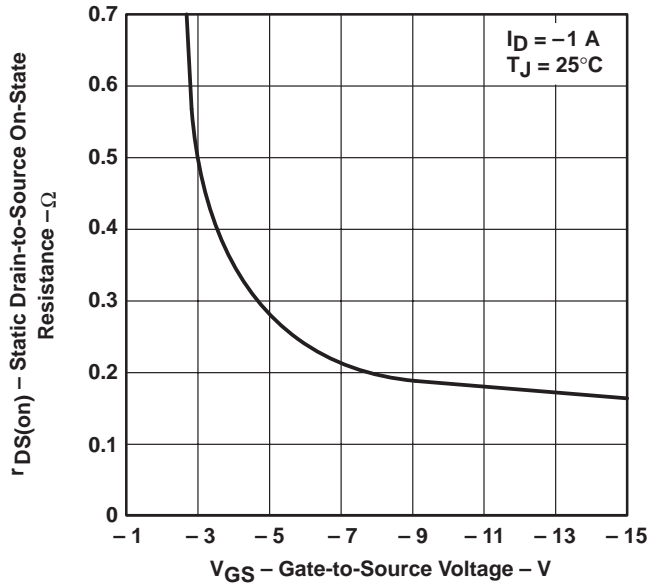

Figure 9

GATE-TO-SOURCE THRESHOLD VOLTAGE  
vs  
JUNCTION TEMPERATURE

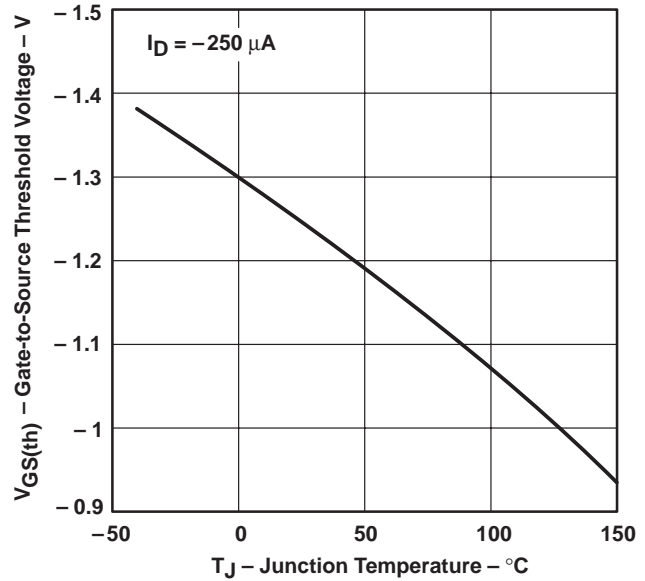

Figure 10

GATE-TO-SOURCE VOLTAGE  
vs  
GATE CHARGE

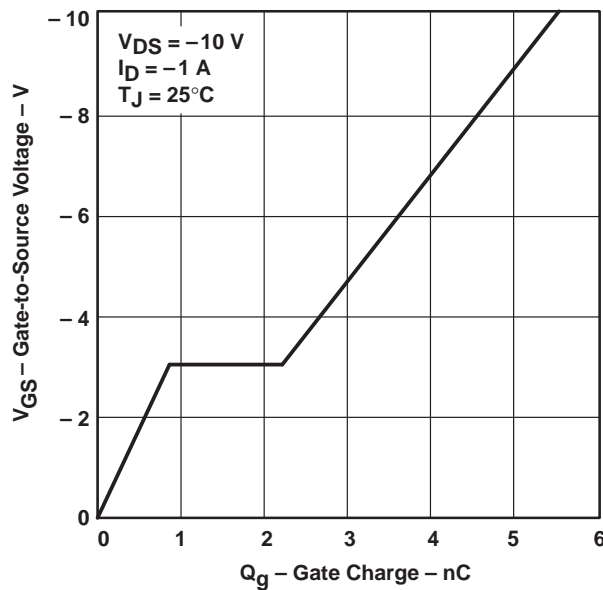
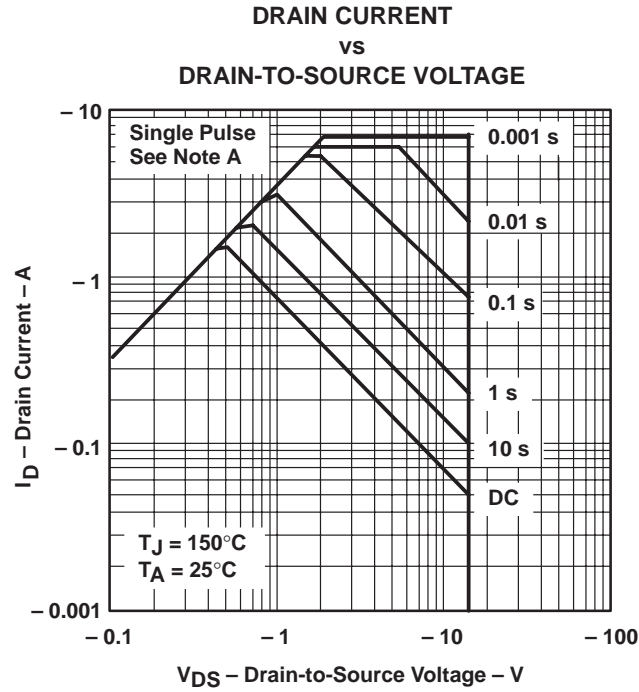

Figure 11



THERMAL INFORMATION



NOTE A: FR4-board-mounted only

Figure 12

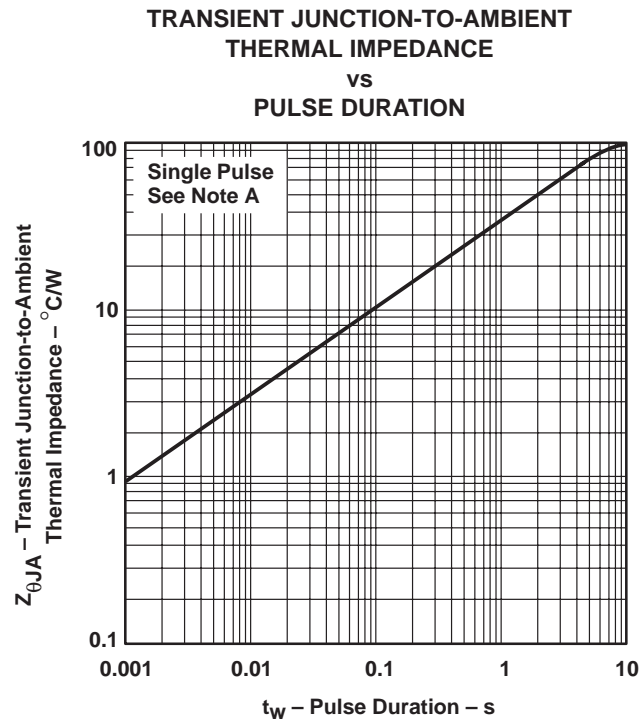

NOTE A: FR4-board-mounted only

Figure 13

# TPS1120, TPS1120Y DUAL P-CHANNEL ENHANCEMENT-MODE MOSFETS

SLVS080A – MARCH 1994 – REVISED AUGUST 1995

## THERMAL INFORMATION

The profile of the heat sinks used for thermal measurements is shown in Figure 14. Board type is FR4 with 1-oz copper and 1-oz tin/lead (63/37) plate. Use of vias or through-holes to enhance thermal conduction was avoided.

Figure 15 shows a family of  $R_{\theta JA}$  curves. The  $R_{\theta JA}$  was obtained for various areas of heat sinks while subject to air flow. Power remained fixed at 0.25 W per device or 0.50 W per package. This testing was done at 25°C.

As Figure 14 illustrates, there are two separated heat sinks for each package. Each heat sink is coupled to the lead that is internally tied to a single MOSFET source and is half the total area, as shown in Figure 15. For example, if the total area shown in Figure 15 is 4 cm<sup>2</sup>, each heat sink is 2 cm<sup>2</sup>.

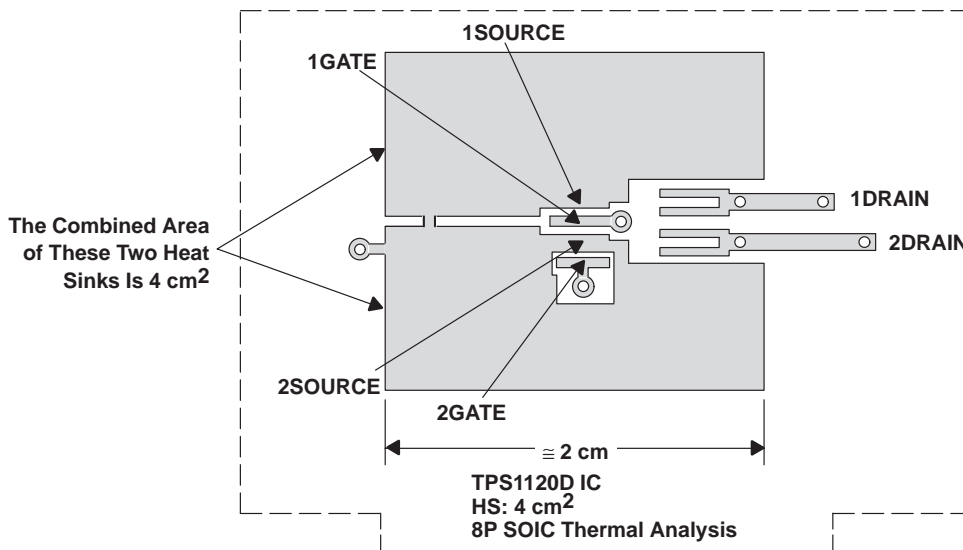

Figure 14. Profile of Heat Sinks

## THERMAL RESISTANCE, JUNCTION-TO-AMBIENT vs AIRFLOW, 25°C

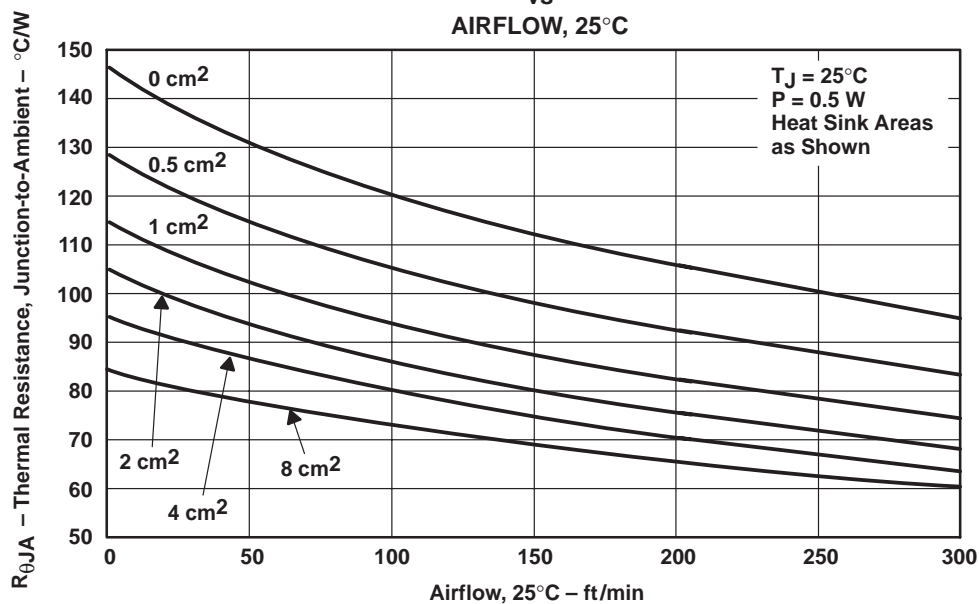

Figure 15

**THERMAL INFORMATION**

Figure 16 illustrates the thermally enhanced (SO) lead frame. Attaching the two MOSFET dies directly to the source terminals allows maximum heat transfer into a power plane.

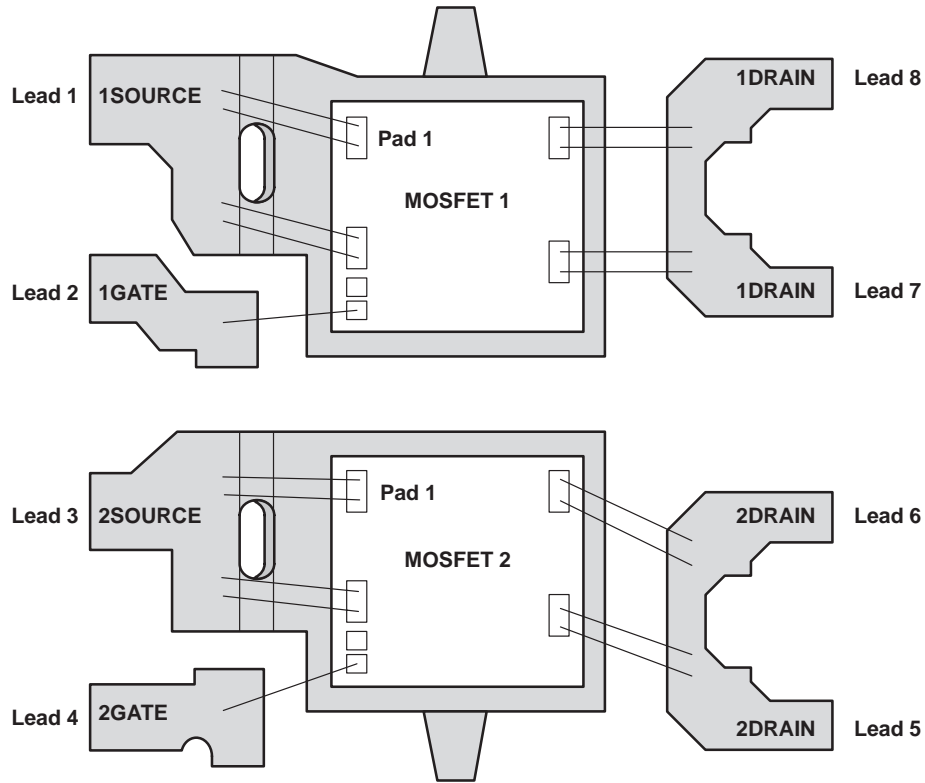

Figure 16. TPS1120 Dual MOSFET SO-8 Lead Frame

**APPLICATION INFORMATION**

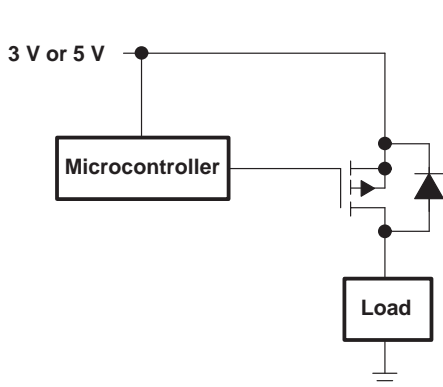

Figure 17. Notebook Load Management

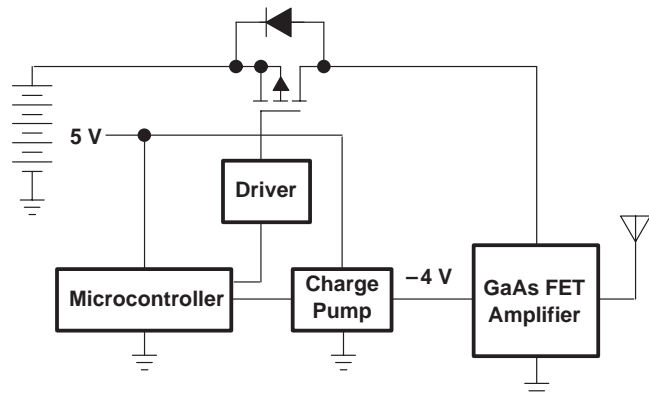

Figure 18. Cellular Phone Output Drive

**PACKAGING INFORMATION**

Orderable Device	Status (1)	Package Type	Package Drawing	Pins	Package Qty	Eco Plan (2)	Lead finish/ Ball material (6)	MSL Peak Temp (3)	Op Temp (°C)	Device Marking (4/5)	Samples
TPS1120D	ACTIVE	SOIC	D	8	75	RoHS & Green	NIPDAU	Level-1-260C-UNLIM		1120	<a href="#">Samples</a>
TPS1120DR	ACTIVE	SOIC	D	8	2500	RoHS & Green	NIPDAU	Level-1-260C-UNLIM		1120	<a href="#">Samples</a>

(1) The marketing status values are defined as follows:

**ACTIVE:** Product device recommended for new designs.

**LIFEBUY:** TI has announced that the device will be discontinued, and a lifetime-buy period is in effect.

**NRND:** Not recommended for new designs. Device is in production to support existing customers, but TI does not recommend using this part in a new design.

**PREVIEW:** Device has been announced but is not in production. Samples may or may not be available.

**OBSOLETE:** TI has discontinued the production of the device.

(2) **RoHS:** TI defines "RoHS" to mean semiconductor products that are compliant with the current EU RoHS requirements for all 10 RoHS substances, including the requirement that RoHS substance do not exceed 0.1% by weight in homogeneous materials. Where designed to be soldered at high temperatures, "RoHS" products are suitable for use in specified lead-free processes. TI may reference these types of products as "Pb-Free".

**RoHS Exempt:** TI defines "RoHS Exempt" to mean products that contain lead but are compliant with EU RoHS pursuant to a specific EU RoHS exemption.

**Green:** TI defines "Green" to mean the content of Chlorine (Cl) and Bromine (Br) based flame retardants meet JS709B low halogen requirements of <=1000ppm threshold. Antimony trioxide based flame retardants must also meet the <=1000ppm threshold requirement.

(3) MSL, Peak Temp. - The Moisture Sensitivity Level rating according to the JEDEC industry standard classifications, and peak solder temperature.

(4) There may be additional marking, which relates to the logo, the lot trace code information, or the environmental category on the device.

(5) Multiple Device Markings will be inside parentheses. Only one Device Marking contained in parentheses and separated by a "~" will appear on a device. If a line is indented then it is a continuation of the previous line and the two combined represent the entire Device Marking for that device.

(6) Lead finish/Ball material - Orderable Devices may have multiple material finish options. Finish options are separated by a vertical ruled line. Lead finish/Ball material values may wrap to two lines if the finish value exceeds the maximum column width.

**Important Information and Disclaimer:**The information provided on this page represents TI's knowledge and belief as of the date that it is provided. TI bases its knowledge and belief on information provided by third parties, and makes no representation or warranty as to the accuracy of such information. Efforts are underway to better integrate information from third parties. TI has taken and continues to take reasonable steps to provide representative and accurate information but may not have conducted destructive testing or chemical analysis on incoming materials and chemicals. TI and TI suppliers consider certain information to be proprietary, and thus CAS numbers and other limited information may not be available for release.

In no event shall TI's liability arising out of such information exceed the total purchase price of the TI part(s) at issue in this document sold by TI to Customer on an annual basis.

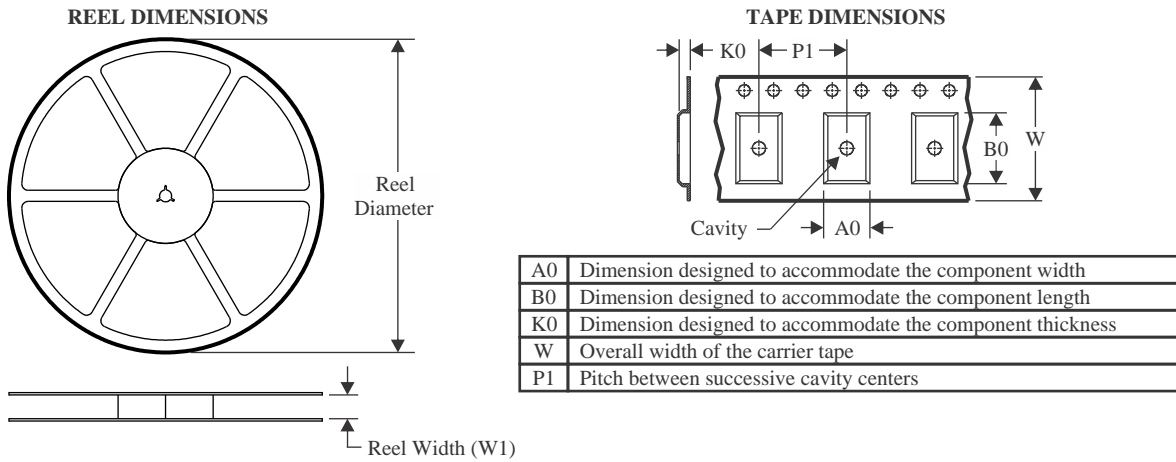
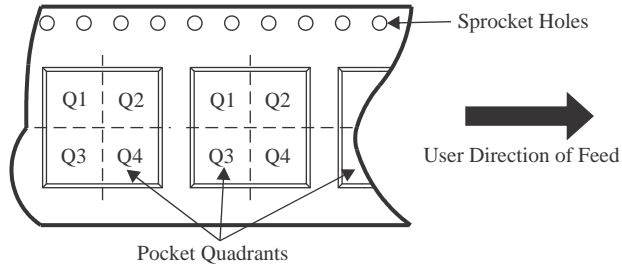

**TAPE AND REEL INFORMATION**

**QUADRANT ASSIGNMENTS FOR PIN 1 ORIENTATION IN TAPE**

\*All dimensions are nominal

Device	Package Type	Package Drawing	Pins	SPQ	Reel Diameter (mm)	Reel Width W1 (mm)	A0 (mm)	B0 (mm)	K0 (mm)	P1 (mm)	W (mm)	Pin1 Quadrant
TPS1120DR	SOIC	D	8	2500	330.0	12.4	6.4	5.2	2.1	8.0	12.0	Q1

**TAPE AND REEL BOX DIMENSIONS**

\*All dimensions are nominal

Device	Package Type	Package Drawing	Pins	SPQ	Length (mm)	Width (mm)	Height (mm)
TPS1120DR	SOIC	D	8	2500	350.0	350.0	43.0

**TUBE**

\*All dimensions are nominal

Device	Package Name	Package Type	Pins	SPQ	L (mm)	W (mm)	T (μm)	B (mm)
TPS1120D	D	SOIC	8	75	505.46	6.76	3810	4

## IMPORTANT NOTICE AND DISCLAIMER

TI PROVIDES TECHNICAL AND RELIABILITY DATA (INCLUDING DATA SHEETS), DESIGN RESOURCES (INCLUDING REFERENCE DESIGNS), APPLICATION OR OTHER DESIGN ADVICE, WEB TOOLS, SAFETY INFORMATION, AND OTHER RESOURCES "AS IS" AND WITH ALL FAULTS, AND DISCLAIMS ALL WARRANTIES, EXPRESS AND IMPLIED, INCLUDING WITHOUT LIMITATION ANY IMPLIED WARRANTIES OF MERCHANTABILITY, FITNESS FOR A PARTICULAR PURPOSE OR NON-INFRINGEMENT OF THIRD PARTY INTELLECTUAL PROPERTY RIGHTS.

These resources are intended for skilled developers designing with TI products. You are solely responsible for (1) selecting the appropriate TI products for your application, (2) designing, validating and testing your application, and (3) ensuring your application meets applicable standards, and any other safety, security, regulatory or other requirements.

These resources are subject to change without notice. TI grants you permission to use these resources only for development of an application that uses the TI products described in the resource. Other reproduction and display of these resources is prohibited. No license is granted to any other TI intellectual property right or to any third party intellectual property right. TI disclaims responsibility for, and you will fully indemnify TI and its representatives against, any claims, damages, costs, losses, and liabilities arising out of your use of these resources.

TI's products are provided subject to [TI's Terms of Sale](#) or other applicable terms available either on [ti.com](https://www.ti.com) or provided in conjunction with such TI products. TI's provision of these resources does not expand or otherwise alter TI's applicable warranties or warranty disclaimers for TI products.

TI objects to and rejects any additional or different terms you may have proposed.

Mailing Address: Texas Instruments, Post Office Box 655303, Dallas, Texas 75265  
Copyright © 2023, Texas Instruments Incorporated

## Looking for pricing, stock, or lifecycle information?

Click below to explore more details on WIN SOURCE:

 [View TPS1120DR](#) on WIN SOURCE

 [Texas Instruments](#) Information

## Optimize Your Supply Chain with WIN SOURCE Solutions

-  Global Sourcing Solution
-  Obsolete Management
-  Cost Control Management
-  Shortage Management
-  Alternative Solution
-  Excess Inventory Management