



THE DATASHEET OF TPS2410PW



Full Featured N+1 and ORing Power Rail Controller

FEATURES

- Control External FET for N+1 and ORing
- Wide Supply Voltage Range of 3 V to 16.5 V
- Controls Buses From 0.8 V to 16.5 V
- Linear or On/Off Control Method
- Internal Charge Pump for N-Channel MOSFET
- Rapid Device Turnoff Protects Bus Integrity
- Positive Gate Control on Hot Insertion
- Soft Turn on Reduces Bus Transients
- Input Voltage Monitoring
- Shorted Gate Monitor
- MOSFET Control-State Indicator
- Industrial Temperature Range: –40°C to 85°C
- Industry-Standard 14-Pin TSSOP Package

APPLICATIONS

- N+1 Power Supplies
- Server Blades
- Telecom Systems
- High Availability Systems

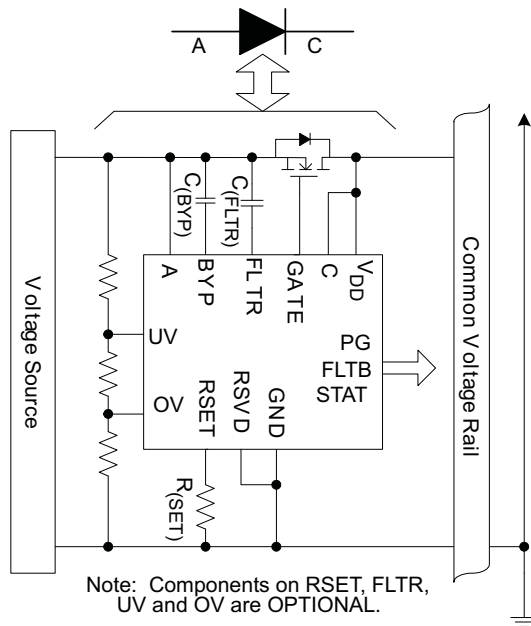

Figure 1. Typical Application

DESCRIPTION

The TPS2410/11 controller, in conjunction with an external N-channel MOSFET, emulates the function of a low forward-voltage diode. The TPS2410/11 can be used to combine multiple power supplies to a common bus in an N+1 configuration, or to combine redundant input power buses. The TPS2410 provides a linear turn-on control while the TPS2411 has an on/off control method.

Applications for the TPS2410/11 include a wide range of systems including servers and telecom. These applications often have either N+1 redundant power supplies, redundant power buses, or both. These redundant power sources must have the equivalent of a diode OR to prevent reverse current during faults and hotplug. A TPS2410/11 and N-channel MOSFET provide this function with less power loss than a schottky diode.

Accurate voltage sensing, programmable fast turn-off threshold, and input filtering allow operations to be tailored for a wide range of implementations and bus characteristics.

A number of monitoring features are provided to indicate voltage bus UV/OV, ON/OFF state, and a shorted MOSFET gate.

Table 1. Family Features

| | TPS2410 | TPS2411 | TPS2412 | TPS2413 |
|-------------------------------|---------|---------|---------|---------|
| Linear gate control | √ | | √ | |
| ON/OFF gate control | | √ | | √ |
| Adjustable turn-off threshold | √ | √ | √ | √ |
| Fast comparator filtering | √ | √ | | |
| Voltage monitoring | √ | √ | | |
| Enable control | √ | √ | | |
| Mosfet fault monitoring | √ | √ | | |
| Status pin | √ | √ | | |



Please be aware that an important notice concerning availability, standard warranty, and use in critical applications of Texas Instruments semiconductor products and disclaimers thereto appears at the end of this data sheet.



This integrated circuit can be damaged by ESD. Texas Instruments recommends that all integrated circuits be handled with appropriate precautions. Failure to observe proper handling and installation procedures can cause damage.

ESD damage can range from subtle performance degradation to complete device failure. Precision integrated circuits may be more susceptible to damage because very small parametric changes could cause the device not to meet its published specifications.

ORDERING INFORMATION⁽¹⁾

| DEVICE | TEMPERATURE | PACKAGE ⁽²⁾ | ORDERING CODE | MARKING |
|---------|---------------|------------------------|---------------|---------|
| TPS2410 | –40°C to 85°C | PW (TSSOP-14) | TPS2410PW | TPS2410 |
| TPS2411 | | | TPS2411PW | TPS2411 |

- (1) Add an R suffix to the device type for tape and reel.
- (2) For the most current package and ordering information, see the Package Option Addendum at the end of this document, or see the TI website at www.ti.com.

ABSOLUTE MAXIMUM RATINGS⁽¹⁾

over operating free-air temperature range, voltage are referenced to GND (unless otherwise noted)

| | VALUE | UNIT |
|--|------------------------------|--------------------|
| A, C, FLTR, V _{DD} , STAT voltage | –0.3 to 18 | V |
| A above C voltage ⁽²⁾ | 7.5 | V |
| C above A voltage | 18 | V |
| GATE ⁽³⁾ , BYP voltage | –0.3 to 30 | V |
| BYP ⁽³⁾ to A voltage | –0.3 to 13 | V |
| GATE above BYP voltage | 0.3 | V |
| FLTR ⁽³⁾ to C voltage | –0.3 to 0.3 | V |
| OV, UV voltage | –0.3 to 5.5 | V |
| RSET voltage ⁽³⁾ | –0.3 to 7 | V |
| FLT B, PG voltage | –0.3 to 18 | V |
| STAT, PG, FLT B sink current | 40 | mA |
| GATE short to A or C or GND | Indefinite | |
| ESD | Human body model | 2 |
| | Charged device model | 500 |
| T _J | Maximum junction temperature | Internally limited |
| T _{stg} | Storage temperature | –65 to 150 |

- (1) Stresses beyond those listed under *absolute maximum ratings* may cause permanent damage to the device. These are stress ratings only and functional operation of the device at these or any other conditions beyond those indicated under *recommended operating conditions* is not implied. Exposure to absolute-maximum-rated conditions for extended periods may affect device reliability.
- (2) See the section "Bidirectional Blocking and Protection of C."
- (3) Voltage should not be applied to these pins.

DISSIPATION RATINGS

| PACKAGE | θ_{JA} – Low k °C/W | θ_{JA} – High k °C/W | POWER RATING High k T _A = 85°C (mW) |
|------------|----------------------------|-----------------------------|---|
| PW (TSSOP) | 173 | 99 | 404 |

RECOMMENDED OPERATING CONDITIONS

voltages are referenced to GND (unless otherwise noted)

| | | MIN | NOM | MAX | UNIT | |
|----------------|--------------------------------------|-----------------------------------|------|----------|--------------|---|
| A, C | Input voltage range TPS2410 | $V_{DD} = V_{(C)}$ ⁽¹⁾ | | 3 | 16.5 | V |
| | | $3 \leq V_{DD} \leq 16.5$ V | | 0.8 | 16.5 | |
| A to C | Operating voltage ⁽²⁾ | | | 5 | V | |
| OV, UV | Voltage range | 0 | | 5.25 | V | |
| STAT, PG, FLTB | Continuous sinking current | | | 6.8 | mA | |
| $R_{(RSET)}$ | Resistance range ⁽³⁾ | 1.5 | | ∞ | k Ω | |
| $C_{(FLTR)}$ | Capacitance Range ⁽³⁾ | 0 | | 1000 | pF | |
| $C_{(BYP)}$ | Capacitance Range ^{(3) (4)} | 800 | 2200 | 10k | pF | |
| T_J | Operating junction temperature | -40 | | 125 | $^{\circ}$ C | |
| T_A | Operating free-air temperature | -40 | | 85 | $^{\circ}$ C | |

- (1) V_{DD} must exceed 3 V to meet GATE drive specifications
 (2) See the section "Bidirectional Blocking and Protection of C."
 (3) Voltage should not be applied to these pins.
 (4) Capacitors should be X7R, 20% or better

ELECTRICAL CHARACTERISTICS: TPS2410/11 ^{(1)(2) (3) (4) (5) (6) (7)}

over operating free-air temperature range (unless otherwise noted)

| PARAMETER | TEST CONDITIONS | MIN | TYP | MAX | UNIT |
|--|---|-------|-------|-------|---------|
| $V_{(A)}$, $V_{(C)}$, V_{DD} | | | | | |
| V_{DD} UVLO | V_{DD} rising | 2.25 | | 2.5 | V |
| | Hysteresis | | 0.25 | | |
| A current | $ I_{(A)} $, Gate in active range | | 0.66 | 1 | mA |
| | $ I_{(A)} $, Gate saturated high | | 0.1 | | |
| C current | $ I_{(C)} $, $V_{AC} \leq 0.1$ V | | | 10 | μ A |
| V_{DD} current | Worst case, gate in active range | | 4.25 | 6 | mA |
| | Gate saturated high | | 1.2 | | |
| UV / OV / PG | | | | | |
| UV threshold voltage | $V_{(UV)}$ rising, $V_{(OV)} = 0$ V, PG goes high | 0.583 | 0.6 | 0.615 | V |
| OV threshold voltage | $V_{(OV)}$ rising, $V_{(UV)} = 1$ V, PG goes low | 0.583 | 0.6 | 0.615 | V |
| Response time | 50-mV overdrive | | 0.3 | 0.6 | μ s |
| Hysteresis | $V_{(UV)}$ and $V_{(OV)}$ | | 7 | | mV |
| PG sink current | $V_{(UV)} = 0$ V, $V_{(OV)} = 0$ V, $V_{(PG)} = 0.4$ V | 4 | | | mA |
| UV / OV leakage current (source or sink) | | | | 1 | μ A |
| PG leakage current (source or sink) | $V_{(UV)} = 1$ V, $V_{(OV)} = 0$ V, $0 \leq V_{(PG)} \leq 5$ V | | | 1 | μ A |
| FLTB | | | | | |
| Sink current | $V_{(FLTB)} = 0.4$ V, $V_{(GATE-A)} = 0$ V, $V_{(A-C)} = 0.1$ V | 4 | | | mA |
| $V_{(GATE-A)}$ fault threshold | $V_{(A)} = V_{(C)} + 20$ mV, $V_{(GATE-A)}$ falling until FLTB switches low | 0.5 | 0.78 | 1 | V |
| $V_{(A-C)}$ fault threshold | $V_{(A-C)} = 0.1$ V, increase $V_{(A-C)}$ until FLTB switches low | 0.325 | 0.425 | 0.525 | V |
| Deglitch on assertion | | | 3.4 | | ms |
| Leakage current (source or sink) | | | | 1 | μ A |

- (1) $[3 \text{ V} \leq V_{(A)} \leq 18 \text{ V}, V_{(C)} = V_{DD}]$ or $[0.8 \text{ V} \leq V_{(A)} \leq 3 \text{ V}, 3 \text{ V} \leq V_{DD} \leq 18 \text{ V}]$
 (2) $C_{(FLTR)} = \text{open}$, $C_{(BYP)} = 2200$ pF, $R_{(RSET)} = \text{open}$, STAT = open, FLT = open
 (3) UV = 1 V, OV = GND
 (4) $-40^{\circ}\text{C} \leq T_J \leq 125^{\circ}\text{C}$
 (5) Positive currents are into pins
 (6) Typical values are at 25 $^{\circ}$ C
 (7) All voltages are with respect to GND.

ELECTRICAL CHARACTERISTICS: TPS2410/11 (continued)

over operating free-air temperature range (unless otherwise noted)

| PARAMETER | TEST CONDITIONS | MIN | TYP | MAX | UNIT |
|--|---|------|------------|------|--------------------|
| STAT | | | | | |
| Sink current | $V_{(STAT)} = 0.4\text{ V}$, $V_{(A)} = V_{(C)} + 0.1\text{ V}$ | 4 | | | mA |
| Input threshold | $V_{DD} \geq 3\text{ V}$ | | $V_{DD}/2$ | | V |
| Response time | From fast turn-off initiation | | | 50 | ns |
| Source pull-up resistance | | 30 | 46 | 60 | k Ω |
| FLTR | | | | | |
| Filter resistance | $R_{(FLTR-C)}$ | | 520 | | Ω |
| TURN ON | | | | | |
| TPS2410 forward turn-on and regulation voltage | | 7 | 10 | 13 | mV |
| TPS2410 forward turn-on / turn-off difference | $R_{(RSET)} = \text{open}$ | | 7 | | mV |
| TPS2411 forward turn-on voltage | | 7 | 10 | 13 | mV |
| TURN OFF | | | | | |
| Fast turn-off threshold voltage | GATE sinks > 10 mA at $V_{(GATE-A)} = 2\text{ V}$ | | | | mV |
| | $V_{(A-C)}$ falling, $R_{(RSET)} = \text{open}$ | 1 | 3 | 5 | |
| | $V_{(A-C)}$ falling, $R_{(RSET)} = 28.7\text{ k}\Omega$ | -17 | -13.25 | -10 | |
| | $V_{(A-C)}$ falling, $R_{(RSET)} = 3.24\text{ k}\Omega$ | -170 | -142 | -114 | |
| Additional threshold shift with STAT held low | | | -157 | | mV |
| Turn-off delay | $V_{(A)} = 12\text{ V}$, $V_{(A-C)}$: 20 mV \rightarrow -20 mV, $V_{(GATE-A)}$ begins to decrease | | 70 | | ns |
| Turn-off time | $V_{(A)} = 12\text{ V}$, $C_{(GATE-GND)} = 0.01\text{ }\mu\text{F}$, $V_{(A-C)}$: 20 mV \rightarrow -20 mV, measure the period to $V_{(GATE)} = V_{(A)}$ | | 130 | | ns |
| GATE | | | | | |
| Gate positive drive voltage, $V_{(GATE-A)}$ | $V_{DD} = 3\text{ V}$, $V_{(A-C)} = 20\text{ mV}$ | 6 | 7 | 8 | V |
| | $5\text{ V} \leq V_{DD} \leq 18\text{ V}$, $V_{(A-C)} = 20\text{ mV}$ | 9 | 10.2 | 11.5 | |
| Gate source current | $V_{(A-C)} = 50\text{ mV}$, $V_{(GATE-A)} = 4\text{ V}$ | 250 | 290 | 350 | μA |
| Soft turn-off sink current (TPS2410) | $V_{(A-C)} = 4\text{ mV}$, $V_{(GATE-A)} = 2\text{ V}$ | 2 | 5 | | mA |
| Fast turn-off pulsed current, $I_{(GATE)}$ | $V_{(A-C)} = -0.1\text{ V}$ | 1.75 | 2.35 | | A |
| | $V_{(GATE)} = 8\text{ V}$ | | | | |
| | $V_{(GATE)} = 5\text{ V}$ | 1.25 | 1.75 | | |
| | Period | 7.5 | 12.5 | | |
| Sustain turn-off current, $I_{(GATE)}$ | $V_{(A-C)} = -0.1\text{ V}$, $V_{(C)} = V_{DD}$, $3 \leq V_{DD} \leq 18\text{ V}$, $2\text{ V} \leq V_{(GATE)} \leq 18\text{ V}$ | 15 | 19.5 | | mA |
| MISCELLANEOUS | | | | | |
| Thermal shutdown temperature | Temperature rising, T_J | | 135 | | $^{\circ}\text{C}$ |
| Thermal hysteresis | | | 10 | | $^{\circ}\text{C}$ |

FUNCTIONAL BLOCK DIAGRAM

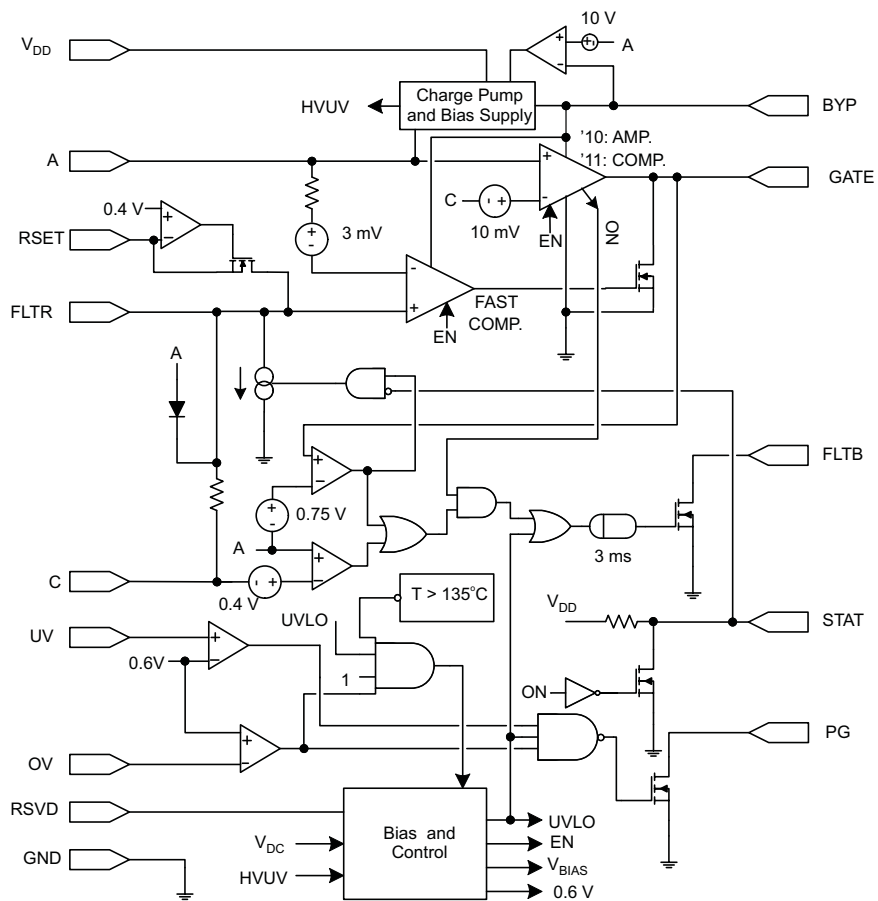

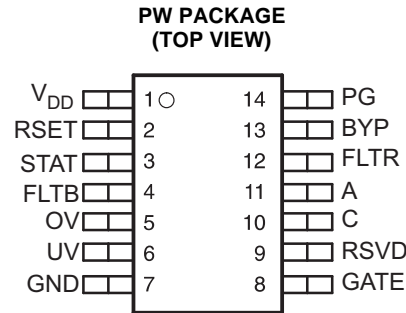

TERMINAL FUNCTIONS

| TERMINAL | | I/O | DESCRIPTION |
|-----------------|-----|-----|--|
| NAME | NO. | | |
| V _{DD} | 1 | PWR | Input power for the gate drive charge pump and internal controls. V _{DD} must be connected to a supply voltage ≥ 3 V. |
| RSET | 2 | I | Connect a resistor to ground to program the turn-off threshold. Leaving RSET open results in a slightly positive V _(A-C) turn-off threshold. |
| STAT | 3 | I/O | STAT is a multifunction pin. A high output indicates that the MOSFET gate is being driven high. Overdriving STAT low while GATE is high shifts the fast-turnoff threshold negative. STAT has a weak pull-up to V _{DD} . |
| FLTB | 4 | O | Open drain fault output. Fault is active (low) for any of the following conditions: 1. Insufficient V _{DD} 2. GATE should be high but is not. 3. The MOSFET should be ON but the forward voltage exceeds 0.4 V. |
| OV | 5 | I | OV is a voltage monitor that contributes to the PG output, and also causes the MOSFET to turn off if it is above the 0.6-V threshold. OV is programmable via an external resistor divider. An OV voltage above 0.6 V indicates a bus voltage that is too high. |
| UV | 6 | I | UV is a voltage monitor that contributes to the PG output. The UV input has a 0.6 V threshold and is programmable via an external resistor divider. A UV voltage above 0.6V indicates a bus voltage that is above its minimum acceptable voltage. A low UV input does not effect the gate drive. |
| GND | 7 | PWR | Device ground. |
| GATE | 8 | O | Connect to the gate of the external MOSFET. Controls the MOSFET to emulate a low forward-voltage diode. |
| RSVD | 9 | PWR | This pin must be connected to GND. |
| C | 10 | I | Voltage sense input that connects to the simulated diode cathode. Connect to the MOSFET drain in the typical configuration. |
| A | 11 | I | Voltage sense input that connects to the simulated diode anode. A also serves as the reference for the charge-pump bias supply on BYP. Connect to the MOSFET source in the typical configuration. |
| FLTR | 12 | I | A capacitor connected from FLTR to A filters the input to the fast comparator. Filtering allows the TPS2410 to ignore spurious transients on the A and C inputs. This pin may be left open to achieve the fastest response time. |
| BYP | 13 | I/O | Connect a storage capacitor from BYP to A to filter the gate drive supply voltage. |
| PG | 14 | O | An open-drain Power Good indicator. PG is open if the UV input is above its threshold, the OV is below its threshold, and the internal UVLO is satisfied. |

DETAILED DESCRIPTION

The following descriptions refer to the pinout and the functional block diagram.

A, C: The A pin serves as the simulated diode anode and the C as the cathode. GATE is driven high when $V_{(AC)}$ exceeds 10 mV. Both devices provide a strong GATE pull-down when $V_{(AC)}$ is less than the programmable fast turn-off threshold. The TPS2410 has a soft pull-down when $V_{(AC)}$ is less than 10 mV but above the fast turn-off threshold.

Several internal comparator and amplifier circuits monitor these two pins. The inputs are protected from excess differential voltage by a clamp diode and series resistance. If C falls below A by more than about 0.7 V, a small current flows out of A. Protect the internal circuits with an external clamp if C can be more than 6 V lower than A. A small signal clamp diode and 1-k Ω resistor, or circuit per [Figure 18](#) are suitable.

The internal charge pump output, which provides bias power to the comparators and voltage to drive GATE, is referenced to A. Some charge pump current appears on A due to this topology. The A and C pins should be Kelvin connected to the MOSFET source and drain. A and C connections should also be short and low impedance, with special attention to the A connection. Residual noise from the charge pump can be reduced with a bypass capacitor at A if the application permits.

BYP: BYP is the internal charge pump output, and the positive supply voltage for internal comparator circuits and GATE driver. A capacitor must be connected from BYP to A. While the capacitor value is not critical, a 2200-pF ceramic is recommended. Traces to this part must be kept short and low impedance to provide adequate filtering. Shorting this pin to a voltage below A damages the TPS2410/11.

FLTR: The internal fast comparator input may be filtered by placing a small capacitor from FLTR to A. This is useful in situations where the ambient noise or transients might falsely trigger a MOSFET turnoff. While $C_{(FLTR)}$ will suppress small transients, large voltage reversals will see relatively small additional turn-off delay.

FLTR is clamped to C and should only be used with a capacitor as shown in [Figure 14](#). Connections to FLTR should be short and direct to minimize parasitic capacitive loading and crosstalk. The filter pin may not be shorted to any other voltage.

FLTB: The FLTB pin is the open-drain fault output. FLTB sinks current when the MOSFET should be enabled, but either there is no GATE voltage, $V_{(AC)}$ is greater than 0.4 V with GATE driven ON, the internal UVLO is not satisfied. FLTB has a 3-ms deglitch filter on the falling edge to prevent transients from creating false signals. FLTB may not be valid at voltages below the internal V_{DD} UVLO.

GATE: Gate connects to the external N channel MOSFET gate. GATE is driven positive with respect to A by a driver operating from the voltage on BYP. A time-limited high current discharge source pulls GATE to GND when the fast turn-off comparator is activated. The high-current discharge is followed by a sustaining pull-down. The turn-off circuits are disabled by the thermal shutdown, leaving a resistive pull-down to keep the gate from floating. The gate connection should be kept low impedance to maximize turn-off current.

GND: This is the input supply reference. GND should have a low impedance connection to the ground plane. It carries several Amperes of rapid-rising discharge current when the external MOSFET is turned off, and also carries significant charge pump currents.

RSET: A resistor connected from this pin to GND sets the MOSFET fast turn-off comparator threshold. The threshold is slightly positive when the RSET pin is left open. Current drawn by the resistor programs the turn-off voltage to increasing negative values. The TPS2411 must have a negative threshold programmed to avoid an unstable condition at light load. The expression for R(RSET) in terms of the fast comparator-trip voltage, $V_{(OFF)}$, follows.

$$R_{(RSET)} = \left(\frac{-470.02}{V_{(OFF)} - 0.00314} \right) \quad (1)$$

The units of the numerator are ($V \times V/A$). $V_{(OFF)}$ is positive for $V_{(A)}$ greater than $V_{(C)}$, $V_{(OFF)}$ is less than 3 mV, and $R_{(RSET)}$ is in ohms.

RSVD: Connect to ground.

STAT: STAT is a multifunction pin. STAT outputs the status of the GATE pin drive. The internal weak pull-up pulls STAT to V_{DD} when GATE is being driven high and $V_{(GATE)}$ is 0.4 V greater than $V_{(A)}$. If STAT is externally pulled below $V_{DD}/2$ while the pin would otherwise be high, the turnoff threshold is shifted negative (~157 mV) from the RSET programmed value. Interconnecting the STAT pins of redundant devices, in systems that normally have both devices on, reduces the likelihood that both devices will turn off in the event of a transient. See the *FUNCTIONAL BLOCK DIAGRAM, INPUT ORing and STAT*, and [Figure 13](#).

UV, OV, PG: These signals are used to monitor an input voltage for proper range. PG sinks current to GND if UV is below its threshold, OV is above its threshold, or V_{DD} is below the internal UVLO. PG may not be valid when V_{DD} is below the UVLO.

A high input on OV causes GATE to be driven low. UV does not effect the MOSFET operation. This permits OV to be used as an active-high disable.

OV and UV should be connected to ground when not used, and PG may be left open. Multiple PG pins to be wire ORed using a common pull-up resistor.

V_{DD} : V_{DD} is the primary supply for the gate drive charge pump and other internal circuits. This pin must be connected a source that is 3 V or greater when the external MOSFET is to be turned on. V_{DD} may be greater or lower than the controlled bus voltage.

A 0.01- μ F bypass capacitor, or 10- Ω and a 0.0 1- μ F filter, is recommended because charge pump currents are drawn through V_{DD} .

TYPICAL CHARACTERISTICS

TPS2410 $V_{(AC)}$ REGULATION VOLTAGE vs TEMPERATURE

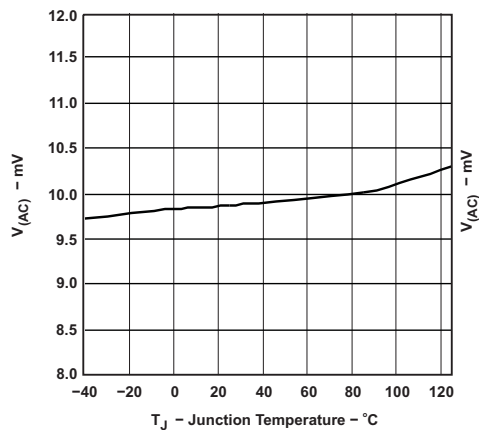

Figure 2.

FAST TURNOFF THRESHOLD vs TEMPERATURE

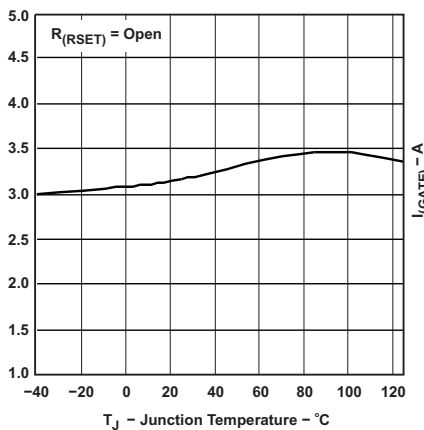

Figure 3.

PULSED GATE SINKING CURRENT vs GATE VOLTAGE

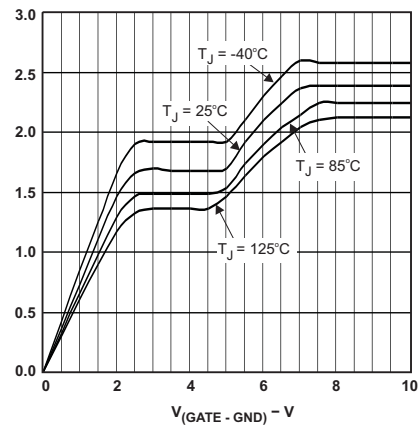

Figure 4.

TURNON DELAY vs V_{DD} (POWER APPLIED UNTIL GATE IS ACTIVE)

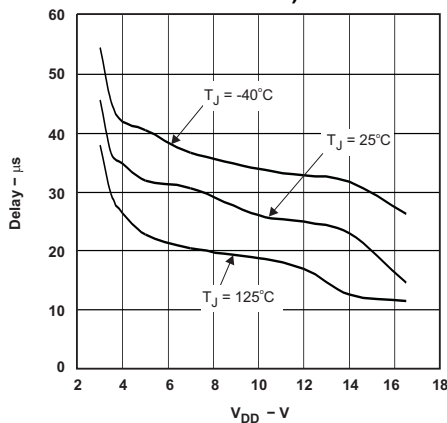

Figure 5.

V_{DD} CURRENT vs V_{DD} VOLTAGE (GATE SATURATED HIGH)

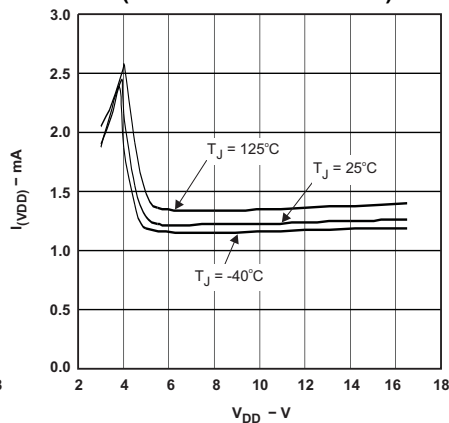

Figure 6.

TYPICAL CHARACTERISTICS (continued)

TYPICAL TURNOFF WITH TWO ORED DEVICES ACTIVE

($V_{DD} = 12\text{ V}$, $I_{(LOAD)} = 5\text{ A}$, IRL3713,

TRANSIENT APPLIED TO LEFT SIDE)

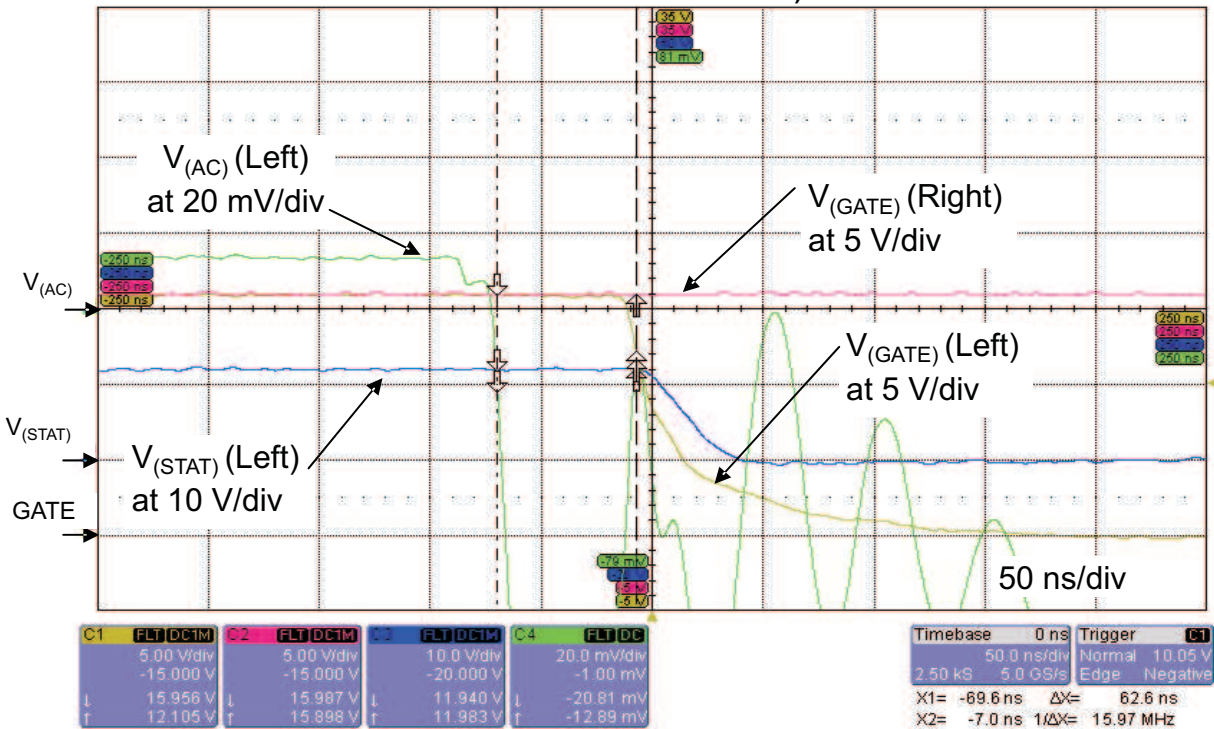

Figure 7.

TYPICAL TURNOFF AND RECOVERY WITH TWO ORED DEVICES ACTIVE

($V_{DD} = 3\text{ V}$, $V_A = 18\text{ V}$, $I_{(LOAD)} = 5\text{ A}$, IRL3713,

TRANSIENT APPLIED TO LEFT SIDE)

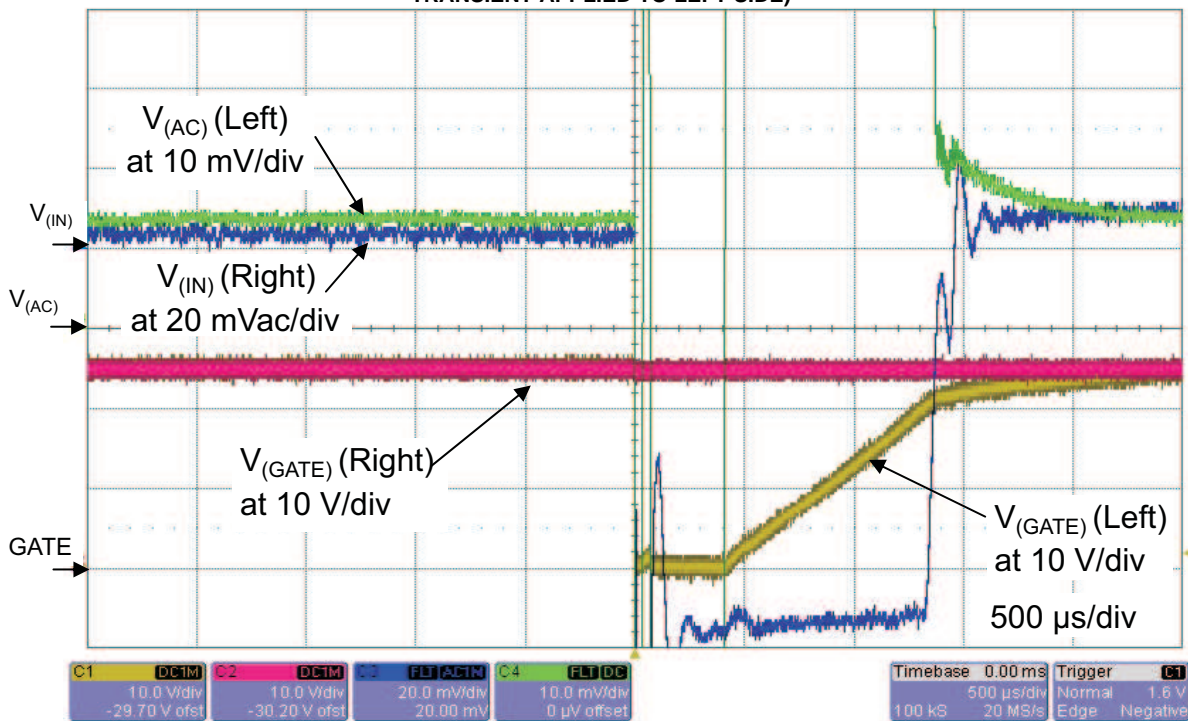

Figure 8.

TYPICAL CHARACTERISTICS (continued)

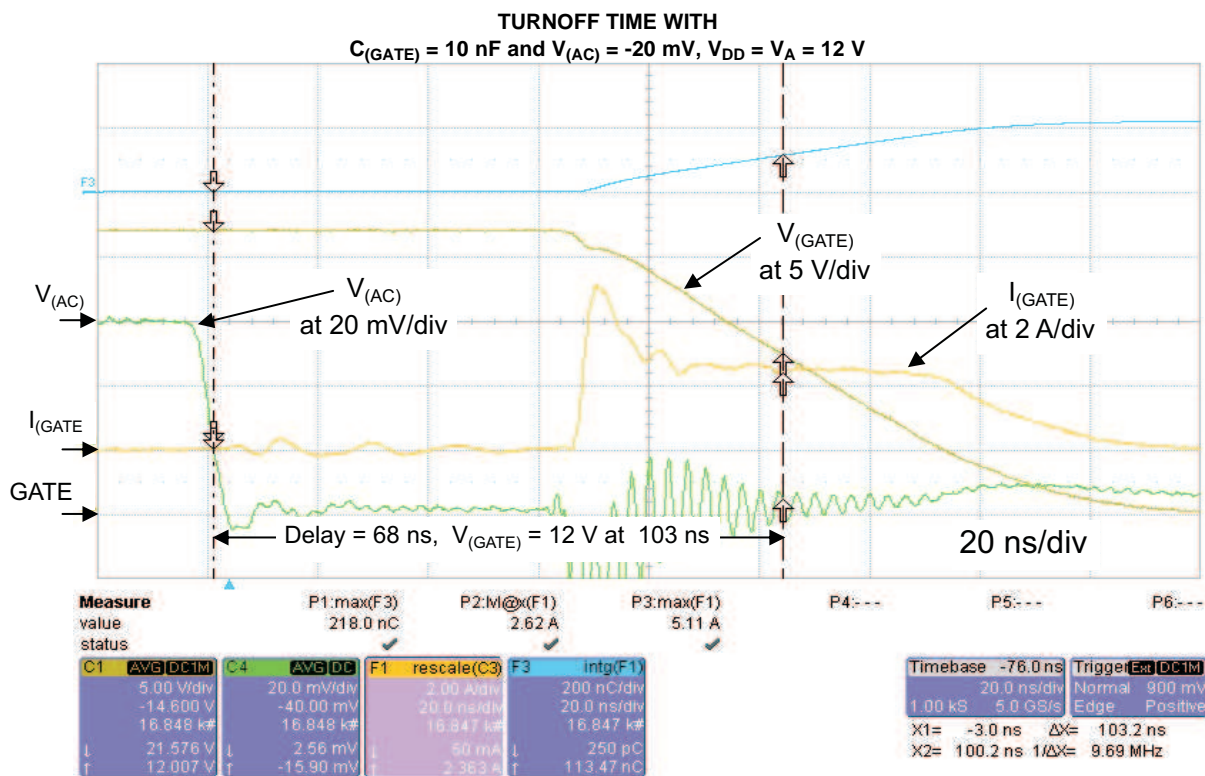

Figure 9.

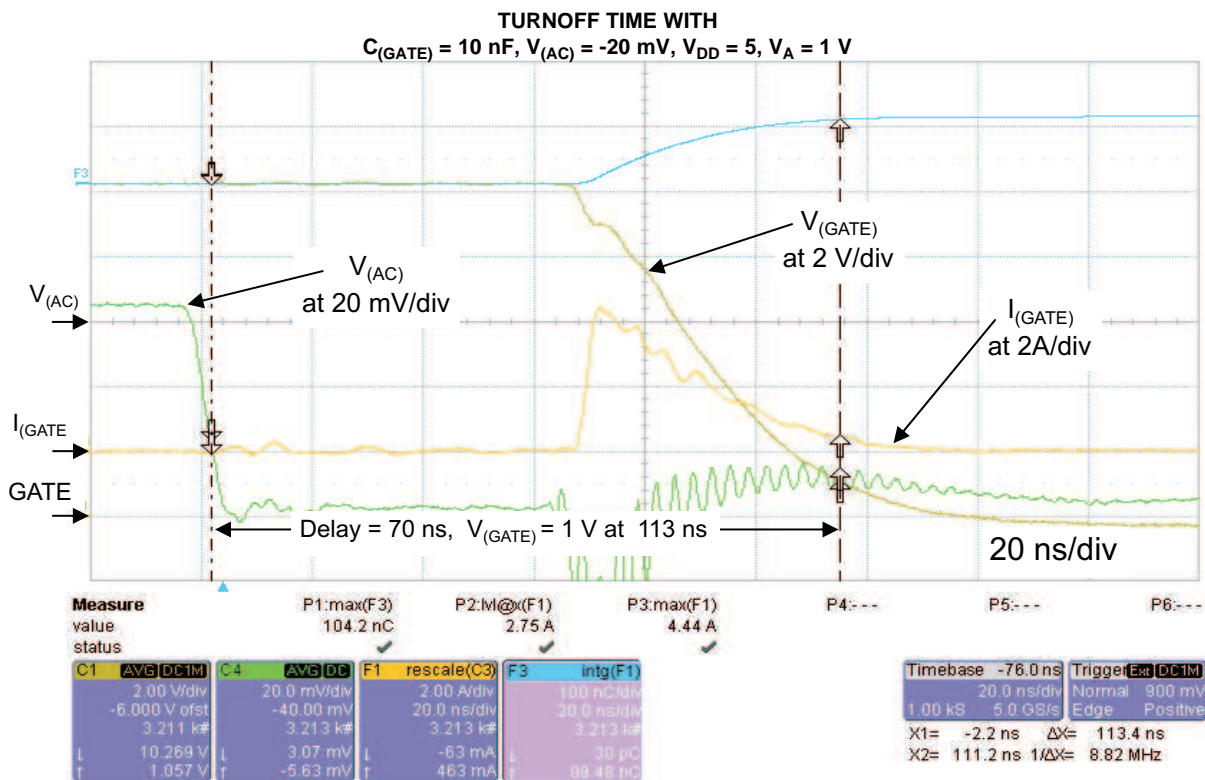

Figure 10.

APPLICATION INFORMATION

OVERVIEW

The TPS2410/11 is designed to allow output ORing in N+1 power supply applications (see Figure 12) and input-power bus ORing in redundant source applications (see Figure 13). The TPS2410/11 and external MOSFET emulate a discrete diode to perform this unidirectional power combining function. The advantage to this emulation is lower forward voltage drop and the ability to tune operation.

The TPS2410 turns the MOSFET on with a linear control loop that regulates $V_{(AC)}$ to 10 mV as shown in Figure 11. With the gate low, and $V_{(AC)}$ increasing to 10 mV, the amplifier drives GATE high with all available output current until regulation is reached. The regulator controls $V_{(GATE)}$ to maintain $V_{(AC)}$ at 10 mV as long as the MOSFET $r_{DS(on)} \times I_{(DRAIN)}$ is less than this the regulated voltage. The regulator drives GATE high, turning the MOSFET fully ON when the $r_{DS(on)} \times I_{(DRAIN)}$ exceeds 10 mV, otherwise $V_{(GATE)}$ will be near $V_{(A)}$ plus the MOSFET gate threshold voltage. If the external circuits force $V_{(AC)}$ below 10 mV and above the programmed fast turnoff, GATE is slowly turned off. GATE is rapidly pulled to ground if $V_{(AC)}$ falls to the RSET programmed fast turn-off threshold.

The TPS2411 turns the MOSFET on and off like a comparator with hysteresis as shown in Figure 11. GATE is driven high when $V_{(AC)}$ exceeds 10 mV, and rapidly turned off if $V_{(AC)}$ falls to the RSET programmed fast turn-off threshold.

System designs should account for the inherent delay between a TPS2410/11 circuit becoming forward biased, and the MOSFET actually turning ON. The delay is the result of the MOSFET gate capacitance charge from ground to its threshold voltage by the 270 μ A gate current. If there are no additional sources holding the ORed rail voltage up, the MOSFET internal diode will conduct and maintain voltage on the ORed output, but there will be some voltage droop. This condition is analogous to the power source being ORed in this case. The DC/DC converter output voltage droops when its load increases from zero to a high value. Load sharing techniques that keep all ORed sources active solve this condition.

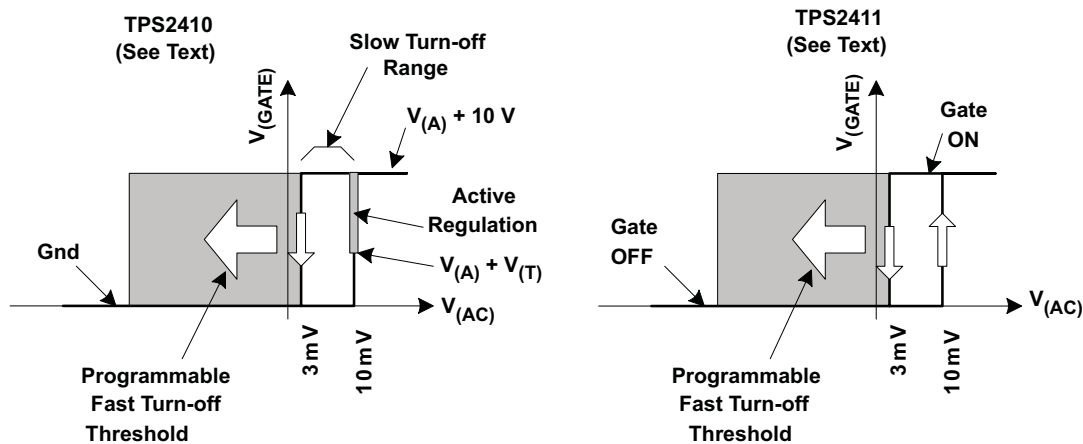

Figure 11. TPS2410/11 Operation

The operation of the two parts is summarized in [Table 2](#).

Table 2. Operation as a Function of V_{AC}

| | $V_{(AC)} \leq \text{Turnoff Threshold}^{(1)}$ | Turnoff Threshold ⁽¹⁾ $\leq V_{AC} \leq 10 \text{ mV}$ | | $V_{(AC)} > 10 \text{ mV}$ |
|---------|--|---|--|----------------------------|
| | | $V_{(AC)}$ Forced $< 10 \text{ mV}$ | (MOSFET $r_{DS(on)} \times I_{LOAD} \leq 10 \text{ mV}$) | |
| TPS2410 | Strong GATE pull-down (OFF) | Weak GATE pull-down (OFF) | $V_{(AC)}$ regulated to 10 mV | GATE pulled high (ON) |
| TPS2411 | Strong GATE pull-down (OFF) | Depends on previous state (Hysteresis region) | | GATE pulled high (ON) |

(1) Turnoff threshold is established by the value of RSET.

TPS2410 vs TPS2411 – MOSFET CONTROL METHODS

The TPS2410 control method yields several benefits. First, the low current GATE driver provides a gentle turn-on and turn-off for slowly rising and falling input voltage. Second, it reduces the tendency for on/off cycling of a comparator based solution at light loads. Third, it avoids reverse currents if the fast turn-off threshold is left positive. The drawback to this method is that the MOSFET appears to have a high resistance at light load when the regulation is active. A momentary output voltage droop occurs when a large step load is applied from a light-load condition. The TPS2410 is a better solution for a mid-rail bus that will be re-regulated.

The TPS2411 turns the MOSFET on if $V_{(AC)}$ is greater than 10 mV, and hard off when $V_{(AC)}$ is less than the RSET programmed threshold. There is no linear control range and slow turn-off. The disadvantage is that the turn-off threshold must be negative (unless a specified load is always present) permitting a continuous reverse current. Under a dynamic reverse voltage fault, the lower threshold voltage may permit a higher peak reverse current. There are a number of advantages to this control method. Step loads from a light load condition are handled without a voltage droop beyond $I \times R$. If the redundant converter fails, applications with redundant synchronous converters may permit a small amount of reverse current at light load in order to assure that the MOSFET is all ready on. The TPS2411 is a better solution for low-voltage busses that will not be re-regulated, and that may see large load steps transients.

These applications recommendations are meant as a starting point, with the needs of specific implementations over-riding them.

N+1 POWER SUPPLY – TYPICAL CONNECTION

The N+1 power supply configuration shown in Figure 12 is used where multiple power supplies are paralleled for either higher capacity, redundancy or both. If it takes N supplies to power the load, adding an extra, identical unit in parallel permits the load to continue operation in the event that any one of the N supplies fails. The supplies are ORed together, rather than directly connected to the bus, to isolate the converter output from the bus when it is plugged-in or fails short. The TPS2410/11 with an external MOSFET emulates the function of the ORing diode.

It is possible for a malfunctioning converter in an ORed topology to create a bus overvoltage if the loading is less than the converter's capacity (e.g. N = 1). The ORed topology shown cannot protect the bus from this condition, even if the ORing MOSFET can be turned off. One common solution is to use two MOSFETs in a back-to-back configuration to provide bidirectional blocking. See the section on *BIDIRECTIONAL BLOCKING AND PROTECTION OF C*.

ORed supplies are usually designed to share power by various means, although the desired operation could implement an active and standby concept. Sharing approaches include both passive, or voltage droop, and active methods. Not all of the output ORing devices may be active depending on the sharing control method, bus loading, distribution resistances, and TPS2410/11 settings.

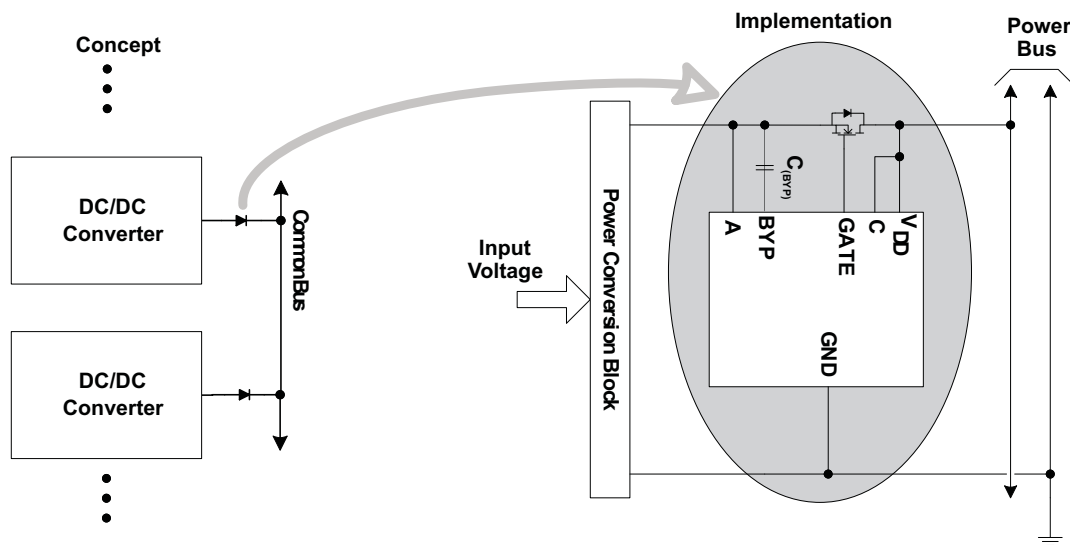

Figure 12. N+1 Power Supply Example

INPUT ORing – TYPICAL CONNECTION

Figure 13 shows how redundant buses may be ORed to a common point to achieve higher reliability. It is possible to have both MOSFETs ON at once if the bus voltages are matched, or the combination of tolerance and regulation causes both TPS2410/11 circuits to see a forward voltage. The ORing MOSFET disconnects the lower-voltage bus, protecting the remaining bus from potential overload by a fault.

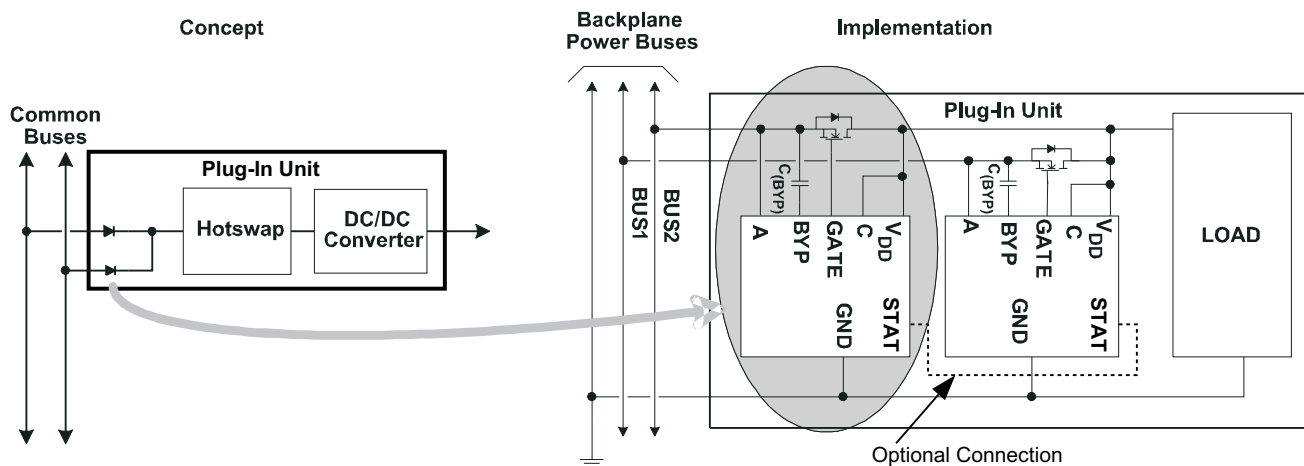

Figure 13. Example ORing of Input Power Buses

SYSTEM DESIGN AND BEHAVIOR WITH TRANSIENTS

The power system, perhaps consisting of multiple supplies, interconnections, and loads, is unique for every product. A power distribution has low impedance, and low loss, which yields high Q by its nature. While the addition of lossy capacitors helps at low frequencies, their benefit at high frequencies is compromised by parasitics. Transient events with rise times in the 10-ns range may be caused by inserting or removing units, load fluctuations, switched loads, supply fluctuations, power supply ripple, and shorts. These transients cause the distribution to ring, creating a situation where ORing controllers may trip off unnecessarily. In particular, when an ORing device turns off due to a reverse current fault, there is an abrupt interruption of the current, causing a fast ringing event. Since this ringing occurs at the same point in the topology as the other ORing controllers, they are the most likely to be effected.

The ability to operate in the presence of noise and transients is in direct conflict with the goal of precise ORing with rapid response to actual faults. A fast response reduces peak stress on devices, reduces transients, and promotes un-interrupted system operation. However, a control with small thresholds and high speed is most likely to be falsely tripped by transients that are not the result of a fault. The power distribution system should be designed to control the transient voltages seen by fast-responding devices such as ORing and hotswap devices.

The TPS2410 was designed with several features to help tune its speed and sensitivity to individual systems. The FLTR pin provides a convenient place to filter the bus voltage before it causes undesired tripping (see *Fast Comparator Input Filtering – $C_{(FLTR)}$*). Some applications may find it possible to use RSET to advantage by setting the reverse turn-off threshold more negative. Last, the STAT pin may be used to desensitize the turnoff threshold of an on-line TPS2410 when a redundant TPS2410 has turned off. This is especially attractive in dual redundant systems (see Input ORing and STAT). Ultimately, the performance may have to be tuned to fit the characteristics of each particular system.

RECOMMENDED OPERATING RANGE

The maximum recommended bus voltage is lower than the absolute maximum voltage ratings on A, C, and V_{DD} solely to provide margin for transients on the bus. Most power systems experience transient voltages above the normal operating level. Short transients, or voltage spikes, may be clamped by the ORing MOSFET to an output capacitor and/or voltage rail depending on the system design. Transient protection, e.g. a TVS diode (transient voltage suppressor, a type of Zener diode), may be required on the input or output if the system design does not inherently limit transient voltages below the TPS2410/11 absolute maximum ratings. If a TVS is required, it must protect to the absolute maximum ratings at the worst case clamping current. The TPS2410/11 will operate properly up to the absolute maximum voltage ratings on A, C, and V_{DD} .

TPS2410 REGULATION-LOOP STABILITY

The TPS2410 uses an internal linear error amplifier to keep the external MOSFET from saturating at light load. This feature has the benefits of setting a turn-off above 0 V, providing a soft turn-off for slowly decaying input voltages, and helps droop-sharing redundancy at light load.

Although the control loop has been designed to accommodate a wide range of applications, there are a few guidelines to be followed to assure stability.

- Select a MOSFET $C_{(ISS)}$ of 1 nF or greater
- Use low ESR bulk capacitors on the output C terminal, typically greater than 100 μ F with less than 50 m Ω ESR
- Maintain some minimum operational load (e.g. 100 mA or more)

Symptoms of stability issues include $V_{(AC)}$ undershoot and possible fast turn-off on large-transient recovery, and a worst-case situation where the gate continually cycles on and off. These conditions are solved by following the rules above. Loop stability should not be confused with tripping the fast comparator due to $V_{(AC)}$ tripping the gate off.

Although not common, a condition may arise where the dc/dc converter transient response may cause the GATE to cycle on and off at light load. The converter experiences a load spike when GATE transitions from OFF to ON because the ORed bus capacitor voltage charges abruptly by as much as a diode drop. The load spike may cause the supply output to droop and overshoot, which can result in the ORed capacitor peak charging to the overshoot voltage. When the supply output settles to its regulated value, the ORed bus may be higher than the source, causing the TPS2410/11 to turn the GATE off. While this may not actually cause a problem, its occurrence may be mitigated by control of the power supply transient characteristic and increasing its output capacitance while increasing the ORed load to capacitance ratio. Adjusting the TPS2410 turn-off threshold or using STAT if possible to desensitize the redundant ORing device may help as well. Careful attention to layout and charge-pump noise around the TPS2410/11 helps with noise margin.

The linear gate driver has a pull-up current of 290 μ A and pull-down current of 3 mA typical.

MOSFET SELECTION AND $R_{(RSET)}$

MOSFET selection criteria include voltage rating, voltage drop, power dissipation, size, and cost. The voltage rating consists of both the ability to withstand the rail voltage with expected transients, and the gate breakdown voltage. The MOSFET gate rating should be the minimum of 12 V or the controlled rail voltage. Typically this requires a ± 20 V GATE voltage rating.

While $r_{DS(on)}$ is often chosen with the power dissipation, voltage drop, size and cost in mind, there are several other factors to be concerned with in ORing applications. When using the TPS2410, the minimum voltage across the device is 10 mV. A device that would have a lower voltage drop at full-load would be overspecified. When using a TPS2411 or TPS2410 with RSET programmed to a negative voltage, the permitted static reverse current is equal to the turn-off threshold divided by the $r_{DS(on)}$. While this current may actually be desirable in some systems, the amount may be controlled by selection of $r_{DS(on)}$ and RSET. The practical range of $r_{DS(on)}$ runs from the low milliohms to 40 m Ω for a single MOSFET.

MOSFETs may be paralleled for lower voltage drop (power loss) at high current. For TPS2410 operation, one should plan for only one of the MOSFETs to carry current until the 10 mV regulation point is exceeded and the loop forces GATE fully ON. TPS2411 operation does not rely on linear range operation, so the MOSFETs are all ON or OFF together except for short transitional times. Beyond the control issues, current sharing depends on the resistance match including both the $r_{DS(on)}$ and the connection resistance.

The TPS2410 may be used without a resistor on RSET. In this case, the turnoff $V_{(AC)}$ threshold is about 3 mV. The TPS2411 may only be operated without an RSET programming resistor if the loading provides a higher $V_{(AC)}$. A larger negative turnoff threshold reduces sensitivity to false tripping due to noise on the bus, but permits larger static reverse current. Installing a resistor from RSET to ground creates a negative shift in the fast turn-off threshold per [Equation 2](#).

$$R_{(RSET)} = \left(\frac{-470.02}{V_{(OFF)} - 0.00314} \right) \quad (2)$$

To obtain a -10 mV fast turnoff ($V_{(A)}$ is less than $V_{(C)}$ by 10 mV), $R_{(RSET)} = (-470.02 / (-0.01 - 0.00314)) \approx 35,700\Omega$. If a 10 m Ω $r_{DS(on)}$ MOSFET was used, the reverse turnoff current is calculated as follows.

$$I_{(TURN_OFF)} = \frac{V_{(THRESHOLD)}}{r_{DS(on)}}$$

$$I_{(TURN_OFF)} = \frac{-10 \text{ mV}}{10 \text{ m}\Omega}$$

$$I_{(TURN_OFF)} = -1 \text{ A} \quad (3)$$

The sign indicates that the current is reverse, or flows from the MOSFET drain to source (C to A).

The turn-off speed of a MOSFET is influenced by the effective gate-source and gate-drain capacitance (C_{ISS}). Since these capacitances vary a great deal between different vendor parts and technologies, they should be considered when selecting a MOSFET where the fastest turn-off is desired.

GATE DRIVE, CHARGE PUMP AND C_(BYP)

Gate drive of 270 μ A typical is generated by an internal charge pump and current limiter. A separate supply, V_{DD}, is provided to avoid having the large charge pump currents interfere with voltage sensing by the A and C pins. The GATE drive voltage is referenced to V_(A) as GATE will only driven high when V_(A) > V_(C). The recommended capacitor on BYP (bypass) must be used in order to form a quiet supply for the internal high-speed comparator. V_(GATE) must not exceed V_(BYP).

FAST COMPARATOR INPUT FILTERING – C_(FLTR)

The FLTR (filter) pin enables a simple method of filtering the input to the fast turn-off comparator as demonstrated in Figure 14. To minimize the impact of a bus fault, the ORing controller turns off the external MOSFET as fast as possible when a voltage reversal occurs. However, having a fast reaction increases the likelihood that noise or non-fault transients may cause false triggering. Examples of such transients are ESD, EFT, RF induction, step loads, and insertion of high-inrush units. The effect of the filter on a time-domain transient are illustrated by assuming a step input from positive to negative. The expression for the time to reach 0 V across the fast comparator inputs follows, where the variables are defined in Figure 14.

$$t_{DLY} = -(R \times C_{(FLTR)}) \times \ln\left(\frac{v_2}{v_2-v_1}\right) \quad (4)$$

Figure 14 graphically illustrates that the external MOSFET is turned off after a longer delay for a small transient than a large voltage reversal. For example, the delay from 10 mV forward to 10-mV reverse is about 52 ns (R = 520 Ω , C = 150 pF), while the delay for a 100-mV reverse transient is 7 ns. It is unlikely that the transient in a real system is a step response, making exact calculations on the effect of the R-C filter to a specific transient difficult.

The need for a C_(FLTR), and its value, is dependent on the electrical noise environment of the particular system. If the electrical environment is understood, the need for the filter, or its value, is selected based on approximations or simulations. If the system is not understood or does not exist when the TPS2410 circuit design is completed, it is recommended that a C_(FLTR) of 100 pF be included in initial schematics. Evaluation of system performance may allow removal of C_(FLTR). The tolerance of the internal resistance is about \pm 25% including temperature variations.

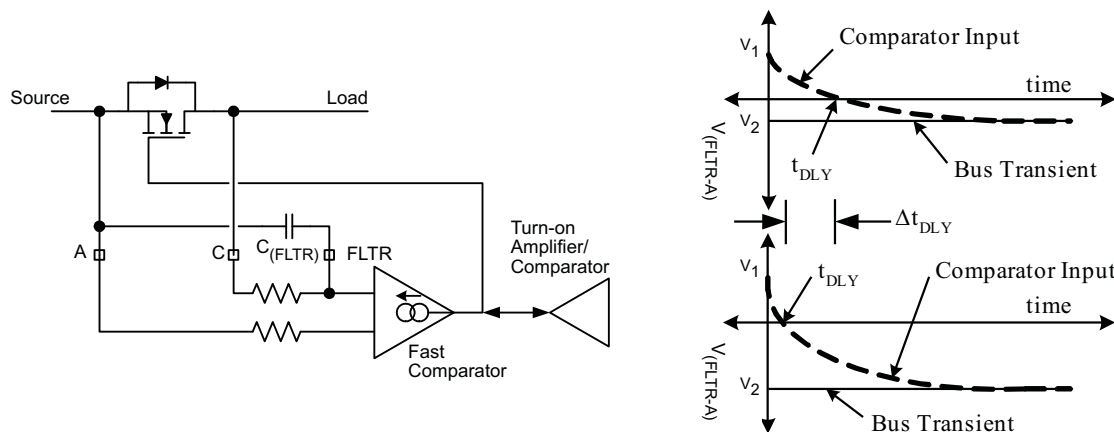

Figure 14. Fast Comparator Input Filtering

UV, OV, AND PG

The UV and OV inputs can be used in a several ways. These include voltage monitoring and forcing the pass MOSFET off.

A voltage bus may be monitored for undervoltage with the UV pin, and overvoltage with the OV pin. Figure 15 demonstrates a basic three resistor divider, however, two separate two resistor dividers may be used. PG is high if $V_{(UV)}$ exceeds the UV threshold, and $V_{(OV)}$ is below the OV threshold, else PG is low. Each of these inputs has a 0.6-V threshold and 7 mV of hysteresis. Optionally, UV and OV may be independently disabled by connecting them to ground, and PG may be left floating if not used. The state of PG is undefined until the internal UVLO is satisfied.

GATE is forced low if $V_{(OV)}$ exceeds 0.6 V. This allows OV to be used as an enable as shown in Figure 15. This can be used for testing purposes, or control of back-to-back MOSFETs to force an output off even though $V_{(AC)}$ is greater than 10 mV.

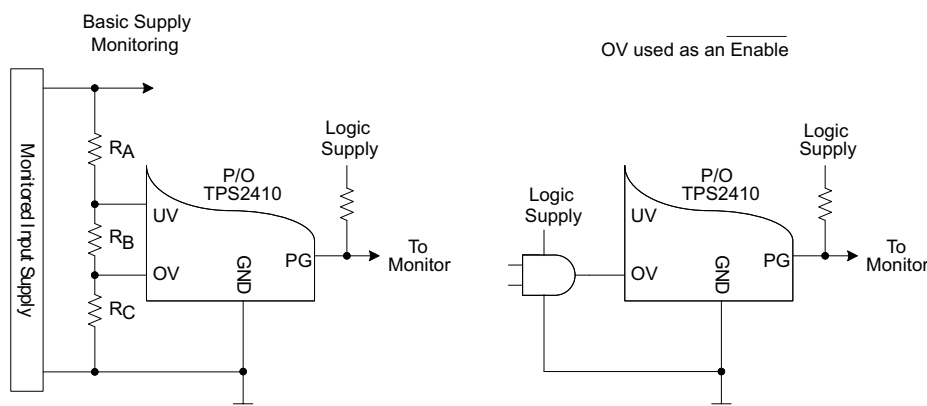

Figure 15. UV, OV, AND PG

V_{DD}, BYP, and POWERING OPTIONS

The separate V_{DD} pin provides flexibility for operational power and controlled rail voltage. While the internal UVLO has been set to 2.5 V, the TPS2410/1 requires at least 3 V to generate the specified GATE drive voltage. Sufficient BYP voltage to run internal circuits occurs at V_{DD} voltages between 2.5 V and 3 V. There are three choices for power, A, C, or a separate supply, two of which are demonstrated in Figure 16. One choice for voltage rails over 3.3 V is to power from C, since it is typically the source of reliable power. Voltage rails below 3.3 V, e.g. 2.5 V and below, should use a separate supply such as 5 V. A separate V_{DD} supply can be used to control voltages above it, for example 5 V powering V_{DD} to control a 12-V bus.

V_{DD} is the main source of power for the internal control circuits. The charge pump that powers BYP draws most of its power from V_{DD}. The input should be low impedance, making a bypass capacitor a preferred solution. A 10-Ω series resistor may be used to limit inrush current into the bypass capacitor, and to provide noise filtering for the supply.

BYP is the interconnection point between a charge pump, V_(AC) monitor amplifiers and comparators, and the gate driver. C_(BYP) must be used to filter the charge pump. A 2200 pF is recommended, but the value is not critical.

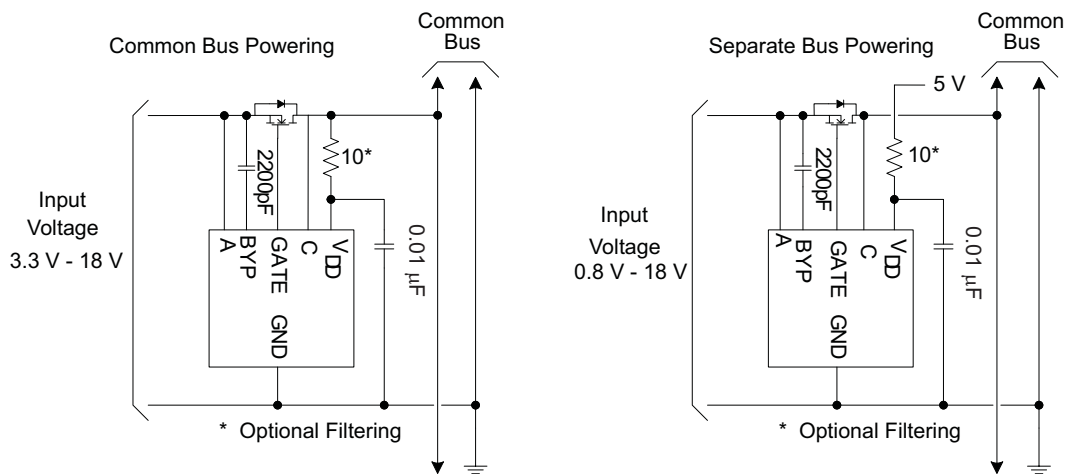

Figure 16. V_{DD} Powering Examples

INPUT ORing AND STAT

STAT provides information regarding the state of the MOSFET gate drive. STAT is pulled to V_{DD} through a 46-k Ω internal pullup, if GATE is being driven high and $V_{(GATE)}$ exceeds $V_{(A)}$ plus 0.4 V. The STAT pin may be directly connected to low-voltage logic by using the logic gate's input ESD clamp to control the voltage or by using a much lower pullup resistor (e.g., 5 k Ω) to the logic supply voltage. STAT must be allowed to rise above $V_{DD}/2$ to avoid effecting the reverse turn-off threshold.

Interconnecting STAT pins can be used to reduce the occurrence of both MOSFETs turning off in topologies such as Figure 13 that normally have both MOSFETs ON. This might occur when there is a noise transient on both buses due to fans cycling on and off, or an ac mains disturbance. If both MOSFETs are ON, and then an ORing circuit turns OFF, the second ORing circuit's fast turnoff threshold is shifted negative by 157 mV from the RSET programmed value because STAT is pulled low. This reduces the probability that it too will turn off as the arrival of the transient, and speed of both circuits, is unlikely to be matched. Maintaining at least one device ON avoids both a bus transient due to the current interruption, and momentary downstream hotswap overload when the ORing recovers. The function of STAT is not limited to the topology of Figure 13 and may be used to dynamically shift the fast turnoff threshold. The internal circuit shown in the *FUNCTIONAL BLOCK DIAGRAM* will assist in designing these applications.

Figure 17 shows how STAT and OV can be used to latch the TPS2410 off. This is useful when a system operation benefits from preventing a failed power module from repeatedly disturbing the bus, and may be used in conjunction with back-to-back MOSFETs. The OV pin must be held low until $V_{(GATE)}$ is 0.4 V above $V_{(A)}$ in order to accomplish a reset.

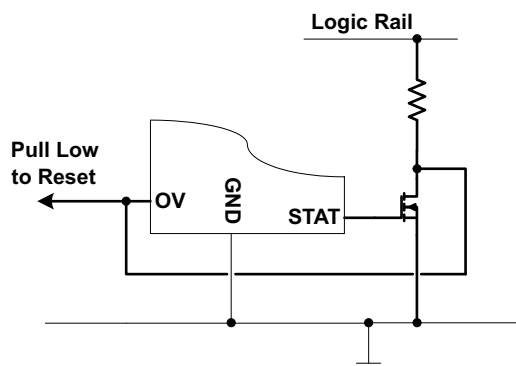

Figure 17. Use of STAT and OV to Latch TPS2411 OFF

BIDIRECTIONAL BLOCKING AND PROTECTION OF C

The TPS2410/11 may be used in applications where bidirectional blocking is desired. This may occur in situations where two different voltages are ORed together, and operation from the lower voltage is desired. Another important application allows isolation of a redundant unit that is generating too high an output voltage. There are two considerations, first is the selection of the V_{DD} source, and second is protection of the C pin from excessive current. Figure 18 provides an example of this type of application.

V_{DD} needs to have voltage applied when A is to be connected to the load. Connecting V_{DD} to C only works when voltage on C is always present before A is connected. V_{DD} may be connected to A, a separate supply, or have voltage from A ORed with voltage from C. OV may be used to force GATE low, even when $V_{(A)}$ is greater than $V_{(C)}$, by driving OV to a voltage between 0.6 V and less than 5.25 V.

The C pin must be protected from excessive current if $V_{(A)}$ can exceed $V_{(C)}$ by more than 5.5 V. With a single MOSFET, $V_{(C)}$ will never be more than a diode drop lower than $V_{(A)}$. When $V_{(AC)}$ is greater than a diode drop, a small current flows out of the C pin into the load. If $V_{(AC)}$ exceeds 5.5 V, a current limiting circuit should be used to protect C. Figure 18 provides an example circuit. Inserting this protection circuit creates a small offset in the forward regulation and threshold voltage.

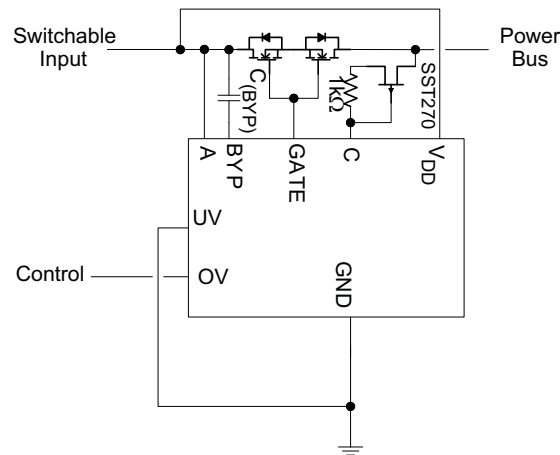

Figure 18. Bidirectional Blocking Example

ORing EXAMPLES

Applications with the TPS2410/11 are not limited to ORing of identical sections. The TPS2410/11 and external MOSFET form a general purpose function block. Figure 19 shows a circuit with ORing between a discrete diode and a TPS2410/MOSFET section. This circuit can be used to combine two different voltages in cases where the output is reregulated, and the additional voltage drop in the Input 1 path is not a concern. An example is ORing of an ac adapter on Input 1 with a lower voltage on Input 2. Figure 20 shows an improved efficiency version of the first in which a P MOSFET replaces the simple diode. This circuit may not be useful in applications where Input 1 may be shorted because the P MOSFET is not managed, permitting reverse current flow. Input 2 should be the lower of the two voltage rails. If Input 1 was the lower voltage rail and connected first, then Input 2 is connected, there will be a momentary reverse current in the P MOSFET. The reverse current occurs because the STAT signal will not go high until V_{GATE} ramps above Input 2 (the higher voltage) by 0.4 V. The Input 1 to Input 2 difference voltage momentarily appears across the PMOS device which is turned on until STAT switches high, causing a reverse current. The highest efficiency with the best fault tolerance is provided by two TPS2410/MOSFET sections.

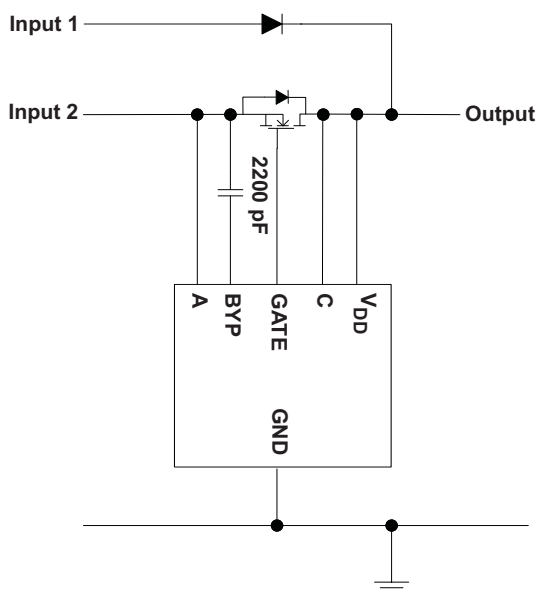

Figure 19. ORing Circuit

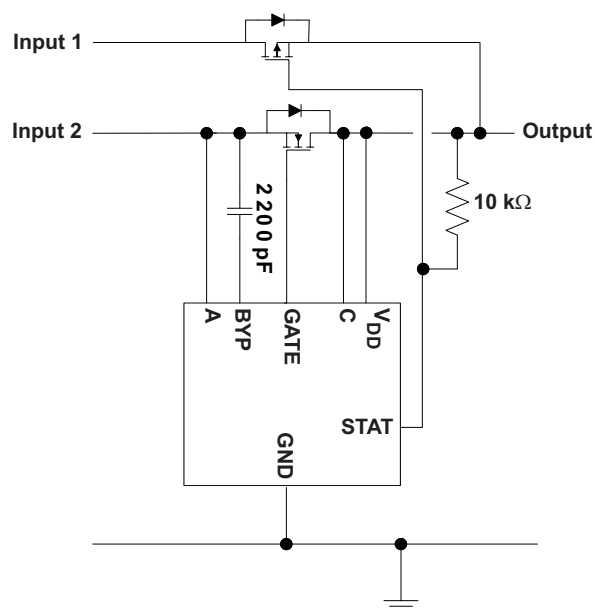

Figure 20. P MOSFET Circuit

The TPS2410 may be a better choice in applications where inputs may be removed, causing an open-circuit input. If the MOSFET was ON when the input is removed, V_{AC} will be virtually zero. If the reverse turn-off threshold is programmed negative, the TPS2410/11 will not pull GATE low. A system interruption could then be created if a short is applied to the floating input. For example, if an ac adapter is first connected to the unit, and then connected to the ac mains, the adapter's output capacitors will look like a momentary short to the unit. A TPS2410 with RSET open will turn the MOSFET OFF when the input goes open circuit.

SUMMARIZED DESIGN PROCEDURE

The following is a summarized design procedure:

1. Choose between the TPS2410 or 2411, see TPS2410 vs TPS2411 – MOSFET Control Methods
2. Choose the V_{DD} source. Table 3 provides a guide for where to connect V_{DD} that covers most cases. V_{DD} may be directly connected to the supply, but an $R_{(VDD)} / C_{(VDD)}$ of $10 \Omega / 0.01 \mu\text{F}$ is recommended.

Table 3. V_{DD} Connection Guide

| $V_A < 3 \text{ V}$ | $3 \text{ V} \leq V_A \leq 3.5 \text{ V}$ | $V_A > 3.5 \text{ V}$ |
|-----------------------------|--|--|
| Bias Supply $> 3 \text{ V}$ | V_A or Bias Supply $> 3 \text{ V}$. V_C if always $> 3 \text{ V}$ | V_C , V_A or Bias for special configurations |

3. Noise voltage and impedance at the A pin should be kept low. $C_{(A)}$ may be required if there is noise on the bus, or A is not low impedance. If either of these is a concern, a $C_{(A)}$ of $0.01 \mu\text{F}$ or more may be required.
4. Select $C_{(BYP)}$ as 2200 pF, X7R, 25-V or 50-V ceramic capacitor.
5. If the noise and transient environment is not well known, design $C_{(FLTR)}$ in, then experimentally determine if it is required. Start with a 100 pF, X7R, 25-V or 50-V ceramic capacitor and adjust if necessary.
6. Select M1 based on considerations of voltage drop, power dissipated, voltage ratings, and gate capacitance. See sections: MOSFET Selection and RSET and TPS2410 Regulation-Loop Stability.
7. Select $R_{(RSET)}$ based on which MOSFET was chosen and reverse current considerations – see MOSFET Selection and RSET. If the noise and transient environment is not well known, make provision for $R_{(RSET)}$ even when using the TPS2410.
8. Configure the UV and OV inputs per the desired behavior – UV, OV, and PG. Calculate the resistor dividers.
9. Add optional interface for PG, FLTB, and STAT as desired.
10. Make sure to connect RSVD to ground.

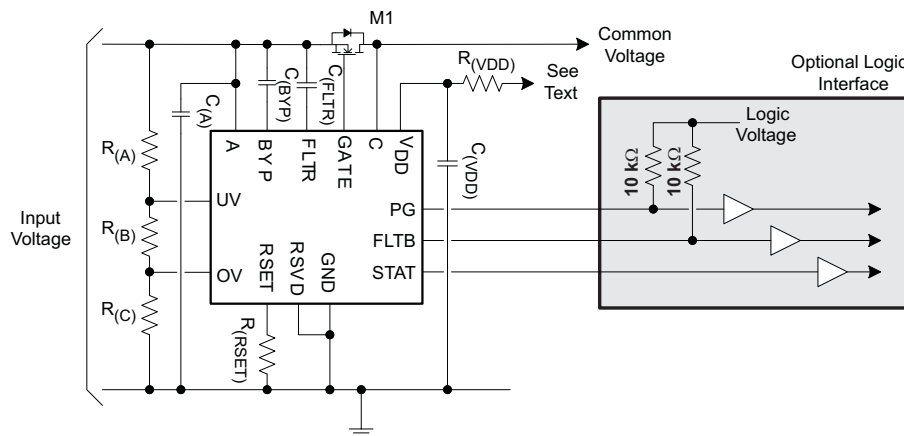

Figure 21. Design Template

Layout Considerations

See Figure 21 for reference designations.

1. The TPS2410/11, M1, and associated components should be used over a ground plane.
2. The GND connection should be short with multiple vias to ground.
3. $C_{(VDD)}$ should be adjacent to the V_{DD} pin with a minimal ground connection length to the plane.
4. The GATE connection should be short and wide (e.g., 0.025" minimum).
5. The C pin should be Kelvin connected to M1.
6. The A pin should be a short, wide, Kelvin connection to M1 and the bus.
7. $C_{(BYP)}$, $C_{(FLTR)}$, and $R_{(RSET)}$ should be kept immediately adjacent to the TPS2410/11 with short leads.
8. Do not run noisy signals adjacent to FLTR.

Revision History

| Changes from Revision B (November, 2006) to Revision C | Page |
|---|-------------|
| • Changed STAT pullup voltage typo | 5 |
| • Changed I/O entry and description of STAT | 6 |
| • Changed STAT Detailed Description | 8 |
| • Changed figure to show STAT connection | 15 |
| • Changed description of STAT interconnection | 21 |

PACKAGING INFORMATION

| Orderable Device | Status (1) | Package Type | Package Drawing | Pins | Package Qty | Eco Plan (2) | Lead/Ball Finish (6) | MSL Peak Temp (3) | Op Temp (°C) | Device Marking (4/5) | Samples |
|------------------|---------------|--------------|--------------------|------|----------------|----------------------------|-------------------------|----------------------|--------------|-------------------------|-------------------------|
| TPS2410PW | ACTIVE | TSSOP | PW | 14 | 90 | Green (RoHS & no Sb/Br) | CU NIPDAU | Level-1-260C-UNLIM | -40 to 85 | TPS2410 | Samples |
| TPS2410PWR | ACTIVE | TSSOP | PW | 14 | 2000 | Green (RoHS & no Sb/Br) | CU NIPDAU | Level-1-260C-UNLIM | -40 to 85 | TPS2410 | Samples |
| TPS2410PWRG4 | ACTIVE | TSSOP | PW | 14 | 2000 | Green (RoHS & no Sb/Br) | CU NIPDAU | Level-1-260C-UNLIM | -40 to 85 | TPS2410 | Samples |
| TPS2411PW | ACTIVE | TSSOP | PW | 14 | 90 | Green (RoHS & no Sb/Br) | CU NIPDAU | Level-1-260C-UNLIM | -40 to 85 | TPS2411 | Samples |
| TPS2411PWR | ACTIVE | TSSOP | PW | 14 | 2000 | Green (RoHS & no Sb/Br) | CU NIPDAU | Level-1-260C-UNLIM | -40 to 85 | TPS2411 | Samples |
| TPS2411PWRG4 | ACTIVE | TSSOP | PW | 14 | 2000 | Green (RoHS & no Sb/Br) | CU NIPDAU | Level-1-260C-UNLIM | -40 to 85 | TPS2411 | Samples |

(1) The marketing status values are defined as follows:

ACTIVE: Product device recommended for new designs.

LIFEBUY: TI has announced that the device will be discontinued, and a lifetime-buy period is in effect.

NRND: Not recommended for new designs. Device is in production to support existing customers, but TI does not recommend using this part in a new design.

PREVIEW: Device has been announced but is not in production. Samples may or may not be available.

OBSOLETE: TI has discontinued the production of the device.

(2) **RoHS:** TI defines "RoHS" to mean semiconductor products that are compliant with the current EU RoHS requirements for all 10 RoHS substances, including the requirement that RoHS substance do not exceed 0.1% by weight in homogeneous materials. Where designed to be soldered at high temperatures, "RoHS" products are suitable for use in specified lead-free processes. TI may reference these types of products as "Pb-Free".

RoHS Exempt: TI defines "RoHS Exempt" to mean products that contain lead but are compliant with EU RoHS pursuant to a specific EU RoHS exemption.

Green: TI defines "Green" to mean the content of Chlorine (Cl) and Bromine (Br) based flame retardants meet JS709B low halogen requirements of <=1000ppm threshold. Antimony trioxide based flame retardants must also meet the <=1000ppm threshold requirement.

(3) MSL, Peak Temp. - The Moisture Sensitivity Level rating according to the JEDEC industry standard classifications, and peak solder temperature.

(4) There may be additional marking, which relates to the logo, the lot trace code information, or the environmental category on the device.

(5) Multiple Device Markings will be inside parentheses. Only one Device Marking contained in parentheses and separated by a "-" will appear on a device. If a line is indented then it is a continuation of the previous line and the two combined represent the entire Device Marking for that device.

⁽⁶⁾ Lead/Ball Finish - Orderable Devices may have multiple material finish options. Finish options are separated by a vertical ruled line. Lead/Ball Finish values may wrap to two lines if the finish value exceeds the maximum column width.

Important Information and Disclaimer:The information provided on this page represents TI's knowledge and belief as of the date that it is provided. TI bases its knowledge and belief on information provided by third parties, and makes no representation or warranty as to the accuracy of such information. Efforts are underway to better integrate information from third parties. TI has taken and continues to take reasonable steps to provide representative and accurate information but may not have conducted destructive testing or chemical analysis on incoming materials and chemicals. TI and TI suppliers consider certain information to be proprietary, and thus CAS numbers and other limited information may not be available for release.

In no event shall TI's liability arising out of such information exceed the total purchase price of the TI part(s) at issue in this document sold by TI to Customer on an annual basis.

TAPE AND REEL INFORMATION

QUADRANT ASSIGNMENTS FOR PIN 1 ORIENTATION IN TAPE

*All dimensions are nominal

| Device | Package Type | Package Drawing | Pins | SPQ | Reel Diameter (mm) | Reel Width W1 (mm) | A0 (mm) | B0 (mm) | K0 (mm) | P1 (mm) | W (mm) | Pin1 Quadrant |
|------------|--------------|-----------------|------|------|--------------------|--------------------|---------|---------|---------|---------|--------|---------------|
| TPS2410PWR | TSSOP | PW | 14 | 2000 | 330.0 | 12.4 | 6.9 | 5.6 | 1.6 | 8.0 | 12.0 | Q1 |
| TPS2411PWR | TSSOP | PW | 14 | 2000 | 330.0 | 12.4 | 6.9 | 5.6 | 1.6 | 8.0 | 12.0 | Q1 |

TAPE AND REEL BOX DIMENSIONS

*All dimensions are nominal

| Device | Package Type | Package Drawing | Pins | SPQ | Length (mm) | Width (mm) | Height (mm) |
|------------|--------------|-----------------|------|------|-------------|------------|-------------|
| TPS2410PWR | TSSOP | PW | 14 | 2000 | 367.0 | 367.0 | 35.0 |
| TPS2411PWR | TSSOP | PW | 14 | 2000 | 367.0 | 367.0 | 35.0 |

IMPORTANT NOTICE

Texas Instruments Incorporated (TI) reserves the right to make corrections, enhancements, improvements and other changes to its semiconductor products and services per JESD46, latest issue, and to discontinue any product or service per JESD48, latest issue. Buyers should obtain the latest relevant information before placing orders and should verify that such information is current and complete.

TI's published terms of sale for semiconductor products (<http://www.ti.com/sc/docs/stdterms.htm>) apply to the sale of packaged integrated circuit products that TI has qualified and released to market. Additional terms may apply to the use or sale of other types of TI products and services.

Reproduction of significant portions of TI information in TI data sheets is permissible only if reproduction is without alteration and is accompanied by all associated warranties, conditions, limitations, and notices. TI is not responsible or liable for such reproduced documentation. Information of third parties may be subject to additional restrictions. Resale of TI products or services with statements different from or beyond the parameters stated by TI for that product or service voids all express and any implied warranties for the associated TI product or service and is an unfair and deceptive business practice. TI is not responsible or liable for any such statements.

Buyers and others who are developing systems that incorporate TI products (collectively, "Designers") understand and agree that Designers remain responsible for using their independent analysis, evaluation and judgment in designing their applications and that Designers have full and exclusive responsibility to assure the safety of Designers' applications and compliance of their applications (and of all TI products used in or for Designers' applications) with all applicable regulations, laws and other applicable requirements. Designer represents that, with respect to their applications, Designer has all the necessary expertise to create and implement safeguards that (1) anticipate dangerous consequences of failures, (2) monitor failures and their consequences, and (3) lessen the likelihood of failures that might cause harm and take appropriate actions. Designer agrees that prior to using or distributing any applications that include TI products, Designer will thoroughly test such applications and the functionality of such TI products as used in such applications.

TI's provision of technical, application or other design advice, quality characterization, reliability data or other services or information, including, but not limited to, reference designs and materials relating to evaluation modules, (collectively, "TI Resources") are intended to assist designers who are developing applications that incorporate TI products; by downloading, accessing or using TI Resources in any way, Designer (individually or, if Designer is acting on behalf of a company, Designer's company) agrees to use any particular TI Resource solely for this purpose and subject to the terms of this Notice.

TI's provision of TI Resources does not expand or otherwise alter TI's applicable published warranties or warranty disclaimers for TI products, and no additional obligations or liabilities arise from TI providing such TI Resources. TI reserves the right to make corrections, enhancements, improvements and other changes to its TI Resources. TI has not conducted any testing other than that specifically described in the published documentation for a particular TI Resource.

Designer is authorized to use, copy and modify any individual TI Resource only in connection with the development of applications that include the TI product(s) identified in such TI Resource. NO OTHER LICENSE, EXPRESS OR IMPLIED, BY ESTOPPEL OR OTHERWISE TO ANY OTHER TI INTELLECTUAL PROPERTY RIGHT, AND NO LICENSE TO ANY TECHNOLOGY OR INTELLECTUAL PROPERTY RIGHT OF TI OR ANY THIRD PARTY IS GRANTED HEREIN, including but not limited to any patent right, copyright, mask work right, or other intellectual property right relating to any combination, machine, or process in which TI products or services are used. Information regarding or referencing third-party products or services does not constitute a license to use such products or services, or a warranty or endorsement thereof. Use of TI Resources may require a license from a third party under the patents or other intellectual property of the third party, or a license from TI under the patents or other intellectual property of TI.

TI RESOURCES ARE PROVIDED "AS IS" AND WITH ALL FAULTS. TI DISCLAIMS ALL OTHER WARRANTIES OR REPRESENTATIONS, EXPRESS OR IMPLIED, REGARDING RESOURCES OR USE THEREOF, INCLUDING BUT NOT LIMITED TO ACCURACY OR COMPLETENESS, TITLE, ANY EPIDEMIC FAILURE WARRANTY AND ANY IMPLIED WARRANTIES OF MERCHANTABILITY, FITNESS FOR A PARTICULAR PURPOSE, AND NON-INFRINGEMENT OF ANY THIRD PARTY INTELLECTUAL PROPERTY RIGHTS. TI SHALL NOT BE LIABLE FOR AND SHALL NOT DEFEND OR INDEMNIFY DESIGNER AGAINST ANY CLAIM, INCLUDING BUT NOT LIMITED TO ANY INFRINGEMENT CLAIM THAT RELATES TO OR IS BASED ON ANY COMBINATION OF PRODUCTS EVEN IF DESCRIBED IN TI RESOURCES OR OTHERWISE. IN NO EVENT SHALL TI BE LIABLE FOR ANY ACTUAL, DIRECT, SPECIAL, COLLATERAL, INDIRECT, PUNITIVE, INCIDENTAL, CONSEQUENTIAL OR EXEMPLARY DAMAGES IN CONNECTION WITH OR ARISING OUT OF TI RESOURCES OR USE THEREOF, AND REGARDLESS OF WHETHER TI HAS BEEN ADVISED OF THE POSSIBILITY OF SUCH DAMAGES.

Unless TI has explicitly designated an individual product as meeting the requirements of a particular industry standard (e.g., ISO/TS 16949 and ISO 26262), TI is not responsible for any failure to meet such industry standard requirements.

Where TI specifically promotes products as facilitating functional safety or as compliant with industry functional safety standards, such products are intended to help enable customers to design and create their own applications that meet applicable functional safety standards and requirements. Using products in an application does not by itself establish any safety features in the application. Designers must ensure compliance with safety-related requirements and standards applicable to their applications. Designer may not use any TI products in life-critical medical equipment unless authorized officers of the parties have executed a special contract specifically governing such use. Life-critical medical equipment is medical equipment where failure of such equipment would cause serious bodily injury or death (e.g., life support, pacemakers, defibrillators, heart pumps, neurostimulators, and implantables). Such equipment includes, without limitation, all medical devices identified by the U.S. Food and Drug Administration as Class III devices and equivalent classifications outside the U.S.

TI may expressly designate certain products as completing a particular qualification (e.g., Q100, Military Grade, or Enhanced Product). Designers agree that it has the necessary expertise to select the product with the appropriate qualification designation for their applications and that proper product selection is at Designers' own risk. Designers are solely responsible for compliance with all legal and regulatory requirements in connection with such selection.

Designer will fully indemnify TI and its representatives against any damages, costs, losses, and/or liabilities arising out of Designer's non-compliance with the terms and provisions of this Notice.

Looking for pricing, stock, or lifecycle information?

Click below to explore more details on WIN SOURCE:

 [View TPS2410PW](#) on WIN SOURCE

 [Texas Instruments](#) Information

Optimize Your Supply Chain with WIN SOURCE Solutions

-  Global Sourcing Solution
-  Obsolete Management
-  Cost Control Management
-  Shortage Management
-  Alternative Solution
-  Excess Inventory Management