



# THE DATASHEET OF TPS2413DR



## TPS241x N+1 and ORing Power Rail Controller

### 1 Features

- Control External FET for N+1 and ORing
- Wide Supply Voltage Range of 3 V to 16.5 V
- Controls Buses From 0.8 V to 16.5 V
- Linear or On/Off Control Method
- Internal Charge Pump for N-Channel MOSFET
- Rapid Device Turnoff Protects Bus Integrity
- Positive Gate Control on Hot Insertion
- Soft Turnon Reduces Bus Transients
- Industrial Temperature Range:  $-40^{\circ}\text{C}$  to  $85^{\circ}\text{C}$
- 8-Pin TSSOP and SOIC Packages

### 2 Applications

- [Rack Server \(Rackmount\)](#)
- [Rack Server \(Blade\)](#)
- [Merchant network & server PSU](#)
- [Battery Backup Unit](#)
- [Telecom systems](#)

### 3 Description

The TPS2412/13 controller, in conjunction with an external N-channel MOSFET, emulates the function of a low forward voltage diode. The TPS2412/13 can be used to combine multiple power supplies to a common bus in an N+1 configuration, or to combine redundant input power buses. The TPS2412 provides a linear turnon control while the TPS2413 has an on/off control method.

Applications for the TPS2412/13 include a wide range of systems including servers and telecom. These applications often have either N+1 redundant power supplies, redundant power buses, or both. Redundant power sources must have the equivalent of a diode OR to prevent reverse current during faults and hotplug. A TPS2412/13 and N-channel MOSFET provide this function with less power loss than a schottky diode.

Accurate voltage sensing and a programmable turnoff threshold allows operation to be tailored for a wide range of implementations and bus characteristics. The TPS2412/13 are lower pin count, reduced feature versions of the TPS2410/11.

#### Device Information<sup>(1)</sup>

PART NUMBER	PACKAGE	BODY SIZE (NOM)
TPS2412, TPS2413	TSSOP (8)	4.40 mm x 3.00 mm
	SOIC (8)	3.91 mm x 4.90 mm

(1) For all available packages, see the orderable addendum at the end of the data sheet.

#### Typical Application Diagram

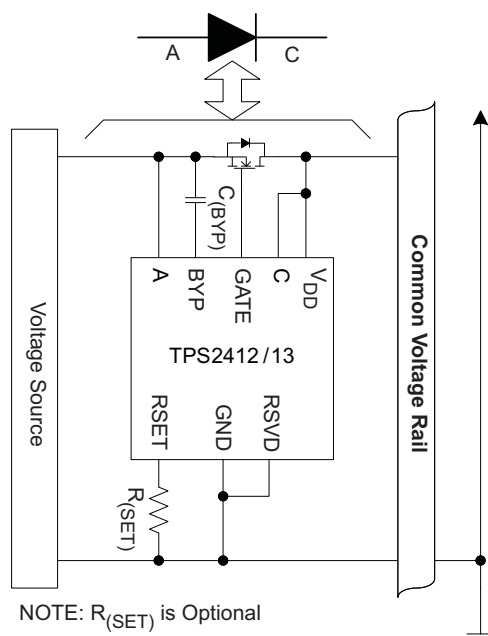

## Table of Contents

<b>1 Features</b> .....	<b>1</b>	8.4 Device Functional Modes.....	<b>13</b>
<b>2 Applications</b> .....	<b>1</b>	<b>9 Application and Implementation</b> .....	<b>14</b>
<b>3 Description</b> .....	<b>1</b>	9.1 Application Information.....	<b>14</b>
<b>4 Revision History</b> .....	<b>2</b>	9.2 Typical Application .....	<b>14</b>
<b>5 Device Comparison Table</b> .....	<b>3</b>	<b>10 Power Supply Recommendations</b> .....	<b>16</b>
<b>6 Pin Configuration and Functions</b> .....	<b>3</b>	10.1 Recommended Operating Range .....	<b>16</b>
<b>7 Specifications</b> .....	<b>4</b>	10.2 $V_{DD}$ , BYP, and Powering Options .....	<b>16</b>
7.1 Absolute Maximum Ratings .....	<b>4</b>	<b>11 Layout</b> .....	<b>17</b>
7.2 ESD Ratings.....	<b>4</b>	11.1 Layout Guidelines .....	<b>17</b>
7.3 Recommended Operating Conditions .....	<b>4</b>	11.2 Layout Example .....	<b>18</b>
7.4 Thermal Information .....	<b>4</b>	<b>12 Device and Documentation Support</b> .....	<b>19</b>
7.5 Electrical Characteristics .....	<b>5</b>	12.1 Related Links .....	<b>19</b>
7.6 Dissipation Ratings .....	<b>5</b>	12.2 Community Resources.....	<b>19</b>
7.7 Typical Characteristics .....	<b>6</b>	12.3 Trademarks .....	<b>19</b>
<b>8 Detailed Description</b> .....	<b>8</b>	12.4 Electrostatic Discharge Caution.....	<b>19</b>
8.1 Overview .....	<b>8</b>	12.5 Glossary .....	<b>19</b>
8.2 Functional Block Diagram .....	<b>9</b>	<b>13 Mechanical, Packaging, and Orderable Information</b> .....	<b>19</b>
8.3 Feature Description.....	<b>9</b>		

## 4 Revision History

Changes from Revision C (November 2015) to Revision D	Page
• Changed Gate positive drive MAX voltage from 11.5 to 12.5 in the <i>Electrical Characteristics</i> table.....	<b>5</b>

Changes from Revision B (September 2008) to Revision C	Page
• Added <i>ESD Ratings</i> table, <i>Feature Description</i> section, <i>Device Functional Modes</i> , <i>Application and Implementation</i> section, <i>Power Supply Recommendations</i> section, <i>Layout</i> section, <i>Device and Documentation Support</i> section, and <i>Mechanical, Packaging, and Orderable Information</i> section. ....	<b>1</b>

## 5 Device Comparison Table

	TPS2410	TPS2411	TPS2412	TPS2413
Linear gate control	√		√	
ON/OFF gate control		√		√
Adjustable turnoff threshold	√	√	√	√
Fast comparator filtering	√	√		
Voltage monitoring	√	√		
Enable control	√	√		
Mosfet fault monitoring	√	√		
Status pin	√	√		

## 6 Pin Configuration and Functions

**PW and D Packages  
8-Pins TSSOP and SOIC  
Top View**

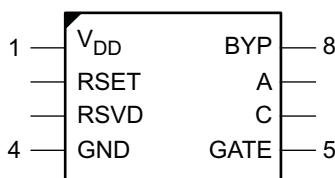

### Pin Functions

PIN		I/O	DESCRIPTION
NAME	NO.		
V <sub>DD</sub>	1	PWR	Input power for the gate drive charge pump and internal controls. V <sub>DD</sub> must be connected to a supply voltage $\geq 3$ V.
RSET	2	I	Connect a resistor to ground to program the turnoff threshold. Leaving RSET open results in a slightly positive V <sub>(A-C)</sub> turnoff threshold.
RSVD	3	PWR	This pin must be connected to GND.
GND	4	PWR	Device ground.
GATE	5	O	Connect to the gate of the external MOSFET. Controls the MOSFET to emulate a low forward-voltage diode.
C	6	I	Voltage sense input that connects to the simulated diode cathode. Connect to the MOSFET drain in the typical configuration.
A	7	I	Voltage sense input that connects to the simulated diode anode. A also serves as the reference for the charge-pump bias supply on BYP. Connect to the MOSFET source in the typical configuration.
BYP	8	I/O	Connect a storage capacitor from BYP to A to filter the gate drive supply voltage.

## 7 Specifications

### 7.1 Absolute Maximum Ratings

over operating free-air temperature range, voltage are referenced to GND (unless otherwise noted)<sup>(1)</sup>

	MIN	MAX	UNIT
A, C, FLTR, V <sub>DD</sub> , voltage	-0.3	18	V
A above C voltage		7.5	V
C above A voltage		18	V
GATE <sup>(2)</sup> , BYP voltage	-0.3	30	V
BYP to A voltage	-0.3	13	V
GATE above BYP <sup>(2)</sup> voltage		0.3	V
RSET <sup>(2)</sup> voltage	-0.3	7	V
GATE short to A or C or GND	Indefinite		
T <sub>J</sub> Maximum junction temperature	Internally limited		°C

- (1) Stresses beyond those listed under *Absolute Maximum Ratings* may cause permanent damage to the device. These are stress ratings only and functional operation of the device at these or any other conditions beyond those indicated under *Recommended Operating Conditions* is not implied. Exposure to absolute-maximum-rated conditions for extended periods may affect device reliability.
- (2) Voltage should not be applied to these pins.

### 7.2 ESD Ratings

		VALUE	UNIT
V <sub>(ESD)</sub> Electrostatic discharge	Human-body model (HBM), per ANSI/ESDA/JEDEC JS-001 <sup>(1)</sup>	±2000	V
	Charged-device model (CDM), per JEDEC specification JESD22-C101 <sup>(2)</sup>	±500	

- (1) JEDEC document JEP155 states that 500-V HBM allows safe manufacturing with a standard ESD control process.
- (2) JEDEC document JEP157 states that 250-V CDM allows safe manufacturing with a standard ESD control process.

### 7.3 Recommended Operating Conditions

voltages are referenced to GND (unless otherwise noted)

		MIN	NOM	MAX	UNIT	
A, C	Input voltage range TPS2412	V <sub>DD</sub> = V <sub>(C)</sub> <sup>(1)</sup>		3	16.5	V
		3 ≤ V <sub>DD</sub> ≤ 16.5 V		0.8	16.5	
A to C	Operational voltage			5	V	
R <sub>(RSET)</sub>	Resistance range <sup>(2)</sup>	1.5		∞	kΩ	
C <sub>(BYP)</sub>	Capacitance Range <sup>(2) (3)</sup>	800	2200	10k	pF	
T <sub>J</sub>	Operating junction temperature	-40		125	°C	
T <sub>A</sub>	Operating free-air temperature	-40		85	°C	

- (1) V<sub>DD</sub> must exceed 3 V to meet gate drive specification
- (2) Voltage should not be applied to these pins.
- (3) Capacitors should be X7R, 20% or better

### 7.4 Thermal Information

THERMAL METRIC <sup>(1)</sup>	TPS241x		UNIT
	PW (TSSOP)	D (SOIC)	
	8 PINS	8 PINS	
R <sub>θJA</sub> Junction-to-ambient thermal resistance	110.3	110.3	°C/W
R <sub>θJC(top)</sub> Junction-to-case (top) thermal resistance	54.7	54.7	°C/W
R <sub>θJB</sub> Junction-to-board thermal resistance	50.9	50.9	°C/W
ψ <sub>JT</sub> Junction-to-top characterization parameter	9.2	9.2	°C/W
ψ <sub>JB</sub> Junction-to-board characterization parameter	50.4	50.4	°C/W
R <sub>θJC(bot)</sub> Junction-to-case (bottom) thermal resistance	N/A	N/A	°C/W

- (1) For more information about traditional and new thermal metrics, see the *Semiconductor and IC Package Thermal Metrics* application report, [SPRA953](#).

## 7.5 Electrical Characteristics

over operating free-air temperature range (unless otherwise noted) <sup>(1)(2)(3)(4)(5)(6)</sup>

PARAMETER	TEST CONDITIONS	MIN	TYP	MAX	UNIT
<b>V<sub>(A)</sub>, V<sub>(C)</sub>, V<sub>DD</sub></b>					
V <sub>DD</sub> UVLO	V <sub>DD</sub> rising	2.25		2.5	V
	Hysteresis		0.25		
A current	I <sub>(A)</sub>  , Gate in active region		0.66	1	mA
	I <sub>(A)</sub>  , Gate saturated high		0.1		
C current	I <sub>(C)</sub>  , V <sub>(AC)</sub> ≤ 0.1 V			10	μA
V <sub>DD</sub> current	Worst case, gate in active region		4.25	6	mA
	Gate saturated high		1.2		
<b>TURNON</b>					
TPS2412 forward turnon and regulation voltage		7	10	13	mV
TPS2412 forward turnon / turnoff difference	R <sub>(RSET)</sub> = open		7		mV
TPS2413 forward turnon voltage		7	10	13	mV
<b>TURNOFF</b>					
Fast turnoff threshold voltage	Gate sinks > 10 mA at V <sub>(GATE-A)</sub> = 2 V	1	3	5	mV
	V <sub>(A-C)</sub> falling, R <sub>(RSET)</sub> = open				
	V <sub>(A-C)</sub> falling, R <sub>(RSET)</sub> = 28.7 kΩ	-17	-13.25	-10	
	V <sub>(A-C)</sub> falling, R <sub>(RSET)</sub> = 3.24 kΩ	-170	-142	-114	
Turnoff delay	V <sub>(A)</sub> = 12 V, V <sub>(A-C)</sub> : 20 mV → -20 mV, V <sub>(GATE-A)</sub> begins to decrease		70		ns
Turnoff time	V <sub>(A)</sub> = 12 V, C <sub>(GATE-GND)</sub> = 0.01 μF, V <sub>(A-C)</sub> : 20 mV → -20 mV, measure the period to V <sub>(GATE)</sub> = V <sub>(A)</sub>		130		ns
<b>GATE</b>					
Gate positive drive voltage, V <sub>(GATE-A)</sub>	V <sub>DD</sub> = 3 V, V <sub>(A-C)</sub> = 20 mV	6	7	8	V
	5 V ≤ V <sub>DD</sub> ≤ 18 V, V <sub>(A-C)</sub> = 20 mV	9	10.2	12.5	
Gate source current	V <sub>(A-C)</sub> = 50 mV, V <sub>(GATE-A)</sub> = 4 V	250	290	350	μA
Soft turnoff sink current (TPS2412)	V <sub>(A-C)</sub> = 4 mV, V <sub>(GATE-A)</sub> = 2 V	2	5		mA
Fast turnoff pulsed current, I <sub>(GATE)</sub>	V <sub>(A-C)</sub> = -0.1 V				A
	V <sub>(GATE)</sub> = 8 V	1.75	2.35		
	V <sub>(GATE)</sub> = 5 V	1.25	1.75		
	Period	7.5	12.5		
Sustain turnoff current, I <sub>(GATE)</sub>	V <sub>(A-C)</sub> = -0.1 V, V <sub>(C)</sub> ≤ V <sub>DD</sub> , 3 V ≤ V <sub>DD</sub> ≤ 18 V, 2 V ≤ V <sub>(GATE)</sub> ≤ 18 V	15	19.5		mA
<b>MISCELLANEOUS</b>					
Thermal shutdown temperature	Temperature rising, T <sub>J</sub>		135		°C
Thermal hysteresis			10		°C

(1) [3 V ≤ V<sub>(A)</sub> ≤ 18 V and V<sub>(C)</sub> = V<sub>DD</sub>] or [0.8 V ≤ V<sub>(A)</sub> ≤ 3 V and 3 V ≤ V<sub>DD</sub> ≤ 18 V]

(2) C<sub>(BYP)</sub> = 2200 pF, R<sub>(RSET)</sub> = open

(3) -40°C ≤ T<sub>J</sub> ≤ 125°C

(4) Positive currents are into pins

(5) Typical values are at 25°C

(6) All voltages are with respect to GND.

## 7.6 Dissipation Ratings

PACKAGE	θ <sub>JA</sub> – Low k °C/W	θ <sub>JA</sub> – High k °C/W	POWER RATING High k T <sub>A</sub> = 85°C (mW)
PW (TSSOP)	258	159	250
D (SO)	176	97.5	410

## 7.7 Typical Characteristics

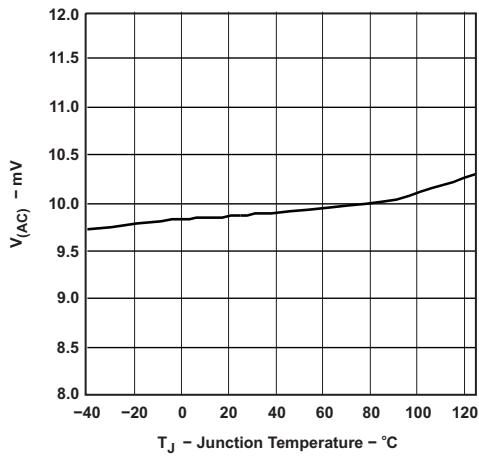

Figure 1. TPS2412  $V_{(AC)}$  Regulation Voltage vs Temperature

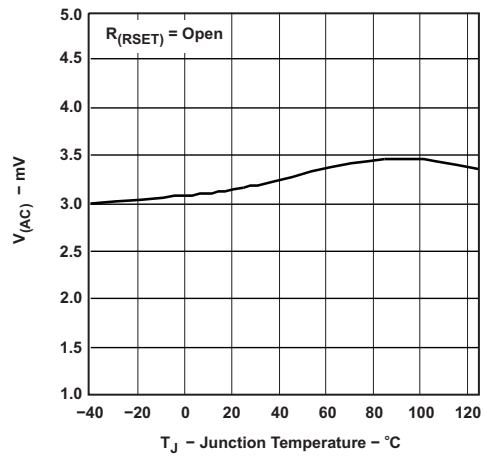

Figure 2. Fast Turnoff Threshold vs Temperature

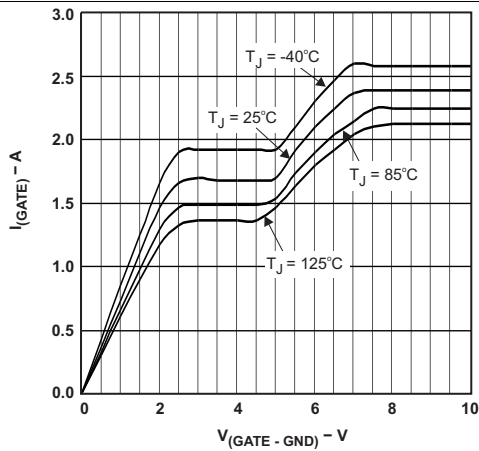

Figure 3. Pulsed Gate Sinking Current vs Gate Voltage

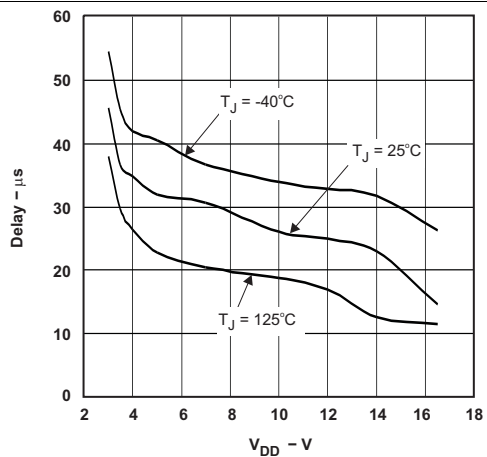

Figure 4. Turnon Delay vs  $V_{DD}$  (Power Applied Until Gate is Active)

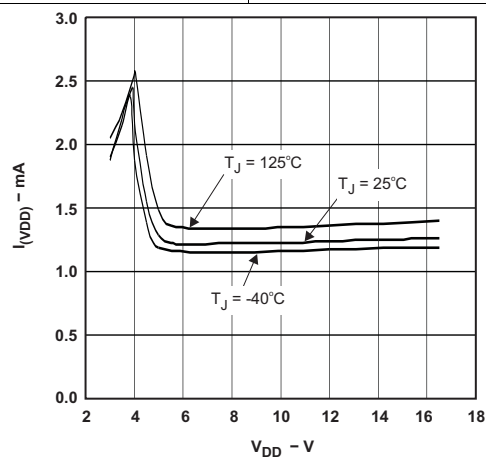
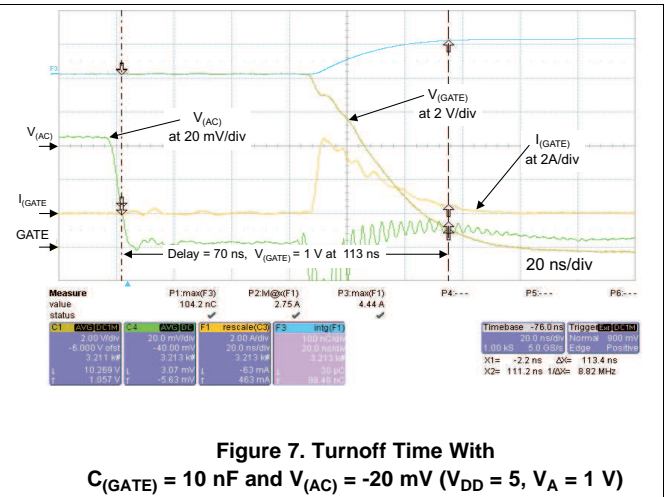
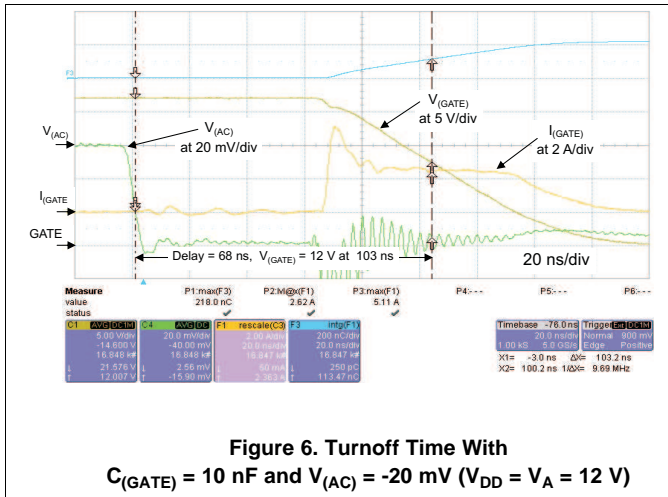

Figure 5.  $V_{DD}$  Current vs  $V_{DD}$  Voltage (Gate Saturated High)

Typical Characteristics (continued)



## 8 Detailed Description

### 8.1 Overview

The TPS2412/13 is designed to allow an output ORing in N+1 power supply applications (see Figure 9), and an input-power bus ORing in redundant source applications (see Figure 10). The TPS2412/13 and external MOSFET emulate a discrete diode to perform this unidirectional power combining function. The advantage to this emulation is lower forward voltage drop and the ability to tune the operation.

The TPS2412 turns the MOSFET on with a linear control loop that regulates  $V_{(AC)}$  to 10 mV as shown in Figure 8. With the gate low, and  $V_{(AC)}$  increasing to 10 mV, the amplifier drives GATE high with all available output current until regulation is reached. The regulator controls  $V_{(GATE)}$  to maintain  $V_{(AC)}$  at 10 mV as long as the MOSFET  $r_{DS(on)} \times I_{(DRAIN)}$  is less than this the regulated voltage. The regulator drives GATE high, turning the MOSFET fully ON when the  $r_{DS(on)} \times I_{(DRAIN)}$  exceeds 10 mV; otherwise,  $V_{(GATE)}$  will be near  $V_{(A)}$  plus the MOSFET gate threshold voltage. If the external circuits force  $V_{(AC)}$  below 10 mV and above the programmed fast turnoff, GATE is slowly turned off. GATE is rapidly pulled to ground if  $V_{(AC)}$  falls to the RSET programmed fast turnoff threshold.

The TPS2413 turns the MOSFET on and off like a comparator with hysteresis as shown in Figure 8. GATE is driven high when  $V_{(AC)}$  exceeds 10 mV, and rapidly turned off if  $V_{(AC)}$  falls to the RSET programmed fast turnoff threshold.

System designs should account for the inherent delay between a TPS2412/13 circuit becoming forward biased, and the MOSFET actually turning ON. The delay is the result of the MOSFET gate capacitance charge from ground to its threshold voltage by the 290  $\mu$ A gate current. If there are no additional sources holding the ORed rail voltage up, the MOSFET internal diode will conduct and maintain voltage on the ORed output, but there will be some voltage drop. This condition is analogous to the power source being ORed in this case. The DC-DC converter output voltage droops when its load increases from zero to a high value. Load sharing techniques that keep all ORed sources active solve this condition.

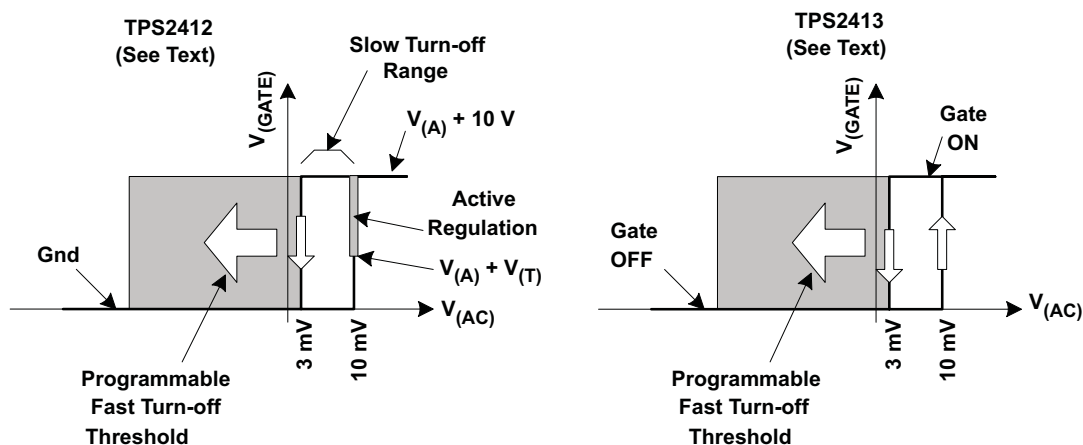

Figure 8. TPS241x Operation

The operation of the two parts is summarized in Table 1.

Table 1. Operation as a Function of  $V_{AC}$

PART	$V_{(AC)} \leq \text{TURNOFF THRESHOLD}^{(1)}$	$\text{TURNOFF THRESHOLD}^{(1)} \leq V_{AC} \leq 10 \text{ mV}$		$V_{(AC)} > 10 \text{ mV}$
		$V_{(AC)} \text{ FORCED} < 10 \text{ mV}$	(MOSFET $r_{DS(on)} \times I_{LOAD} \leq 10 \text{ mV}$ )	
TPS2412	Strong GATE pulldown (OFF)	Weak GATE pulldown (OFF)	$V_{(AC)}$ regulated to 10 mV	GATE pulled high (ON)
TPS2413	Strong GATE pulldown (OFF)	Depends on previous state (Hysteresis region)		GATE pulled high (ON)

(1) Turnoff threshold is established by the value of RSET.

## 8.2 Functional Block Diagram

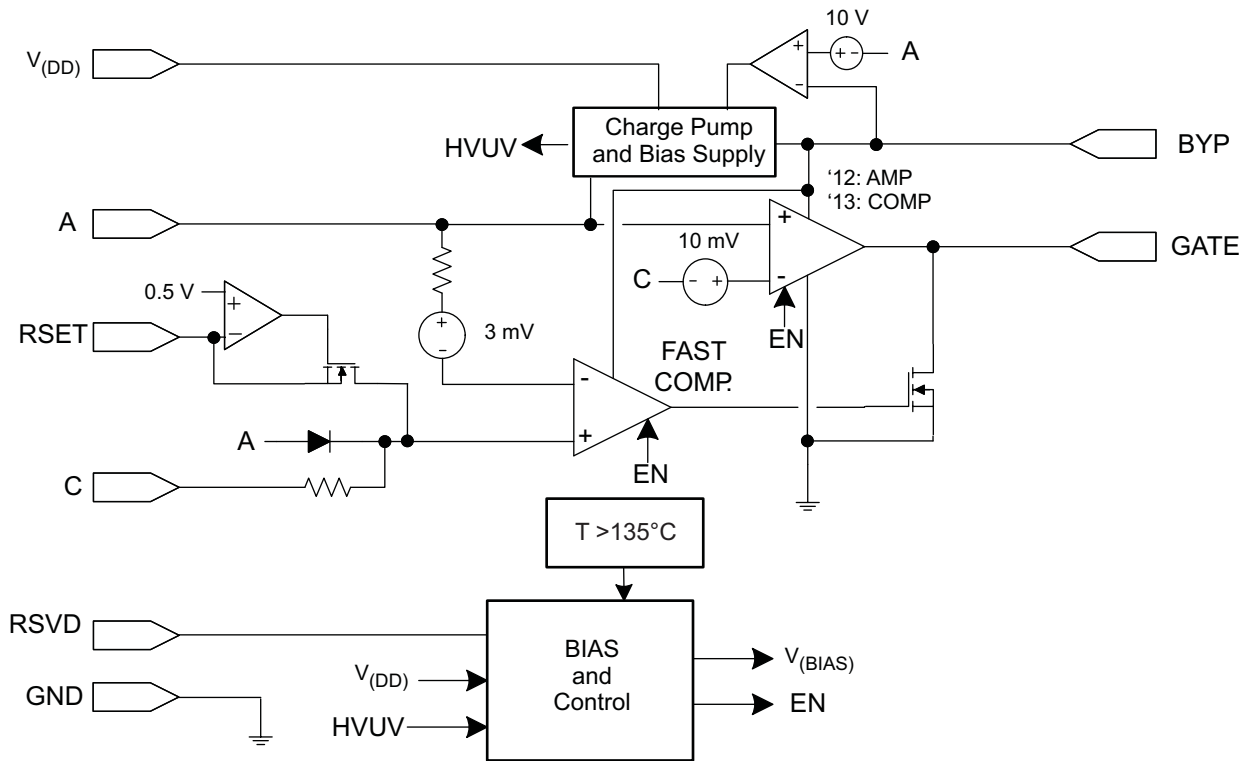

## 8.3 Feature Description

### 8.3.1 Definitions

The following descriptions refer to the pinout and the functional block diagram.

**A, C:** The A pin serves as the simulated diode anode and the C as the cathode. GATE is driven high when  $V_{(AC)}$  exceeds 10 mV. Both devices provide a strong GATE pulldown when  $V_{(AC)}$  is less than the programmable fast turnoff threshold. The TPS2412 has a soft pulldown when  $V_{(AC)}$  is less than 10 mV but above the fast turnoff threshold.

Several internal comparator and amplifier circuits monitor these two pins. The inputs are protected from excess differential voltage by a clamp diode and series resistance. If C falls below A by more than about 0.7 V, a small current flows out of C. Protect the internal circuits with an external clamp if C can be more than 6 V lower than A.

The internal charge pump output, which provides bias power to the comparators and voltage to drive GATE, is referenced to A. Some charge pump current appears on A due to this topology. The A and C pins should be Kelvin connected to the MOSFET source and drain. A and C connections should also be short and low impedance, with special attention to the A connection. Residual noise from the charge pump can be reduced with a bypass capacitor at A if the application permits.

**BYP:** BYP is the internal charge pump output, and the positive supply voltage for internal comparator circuits and GATE driver. A capacitor must be connected from BYP to A. While the capacitor value is not critical, a 2200-pF ceramic is recommended. Traces to this part must be kept short and low impedance to provide adequate filtering.

### CAUTION

Shorting this pin to a voltage below A damages the TPS241x.

## Feature Description (continued)

**GATE:** Gate controls the external N channel MOSFET gate. GATE is driven positive with respect to A by a driver operating from the voltage on BYP. A time-limited high current discharge source pulls GATE to GND when the fast turnoff comparator is activated. The high-current discharge is followed by a sustaining pulldown. The turnoff circuits are disabled by the thermal shutdown, leaving a resistive pulldown to keep the gate from floating. The gate connection should be kept low impedance to maximize turnoff current.

**GND:** This is the input supply reference. GND should have a low impedance connection to the ground plane. It carries several Amperes of rapid-rising discharge current when the external MOSFET is turned off, and also carries significant charge pump currents.

**RSET:** A resistor connected from this pin to GND sets the fast  $V_{(A-C)}$  comparator turnoff threshold. The threshold is slightly positive when the RSET pin is left open. Current drawn by the resistor programs the turnoff voltage to increasing negative values. The TPS2413 must have a negative threshold programmed to avoid an unstable condition at light load. The expression for  $R_{(RSET)}$  in terms of the trip voltage,  $V_{(OFF)}$ , follows.

$$R_{(RSET)} = \left( \frac{-470.02}{V_{(OFF)} - 0.00314} \right) \quad (1)$$

The units of the numerator are  $(V \times V/A)$ .  $V_{(OFF)}$  is positive for  $V_{(A)}$  greater than  $V_{(C)}$ ,  $V_{(OFF)}$  is less than 3 mV, and  $R_{(RSET)}$  is in ohms.

**RSVD:** Connect to ground.

**$V_{DD}$ :**  $V_{DD}$  is the primary supply for the gate drive charge pump and other internal circuits. This pin must be connected a source that is 3 V or greater when the external MOSFET is to be turned on.  $V_{DD}$  may be greater or lower than the controlled bus voltage.

A 0.01- $\mu$ F bypass capacitor, or 10- $\Omega$  and a 0.01- $\mu$ F filter, is recommended because charge pump currents are drawn through  $V_{DD}$ .

### 8.3.2 TPS2412 vs TPS2413 – MOSFET Control Methods

The TPS2412 control method yields several benefits. First, the low-current GATE driver provides a gentle turnon and turnoff for slowly rising and falling input voltage. Second, it reduces the tendency for on/off cycling of a comparator based solution at light loads. Third, it avoids reverse currents if the fast turnoff threshold is left positive. The drawback to this method is that the MOSFET appears to have a high resistance at light load when the regulation is active. A momentary output voltage droop occurs when a large step load is applied from a light-load condition. The TPS2412 is a better solution for a mid-rail bus that is re-regulated.

The TPS2413 turns the MOSFET on if  $V_{(AC)}$  is greater than 10 mV, and the rapid turnoff is activated at the programmed negative threshold. There is no linear control range and slow turnoff. The disadvantage is that the turnoff threshold must be negative (unless a minimum load is always present) permitting a continuous reverse current. Under a dynamic reverse voltage fault, the lower threshold voltage may permit a higher peak reverse current. There are a number of advantages to this control method. Step loads from a light load condition are handled without a voltage droop beyond  $I \times R$ . If the redundant converter fails, applications with redundant synchronous converters may permit a small amount of reverse current at light load to assure that the MOSFET is all ready on. The TPS2413 is a better solution for low-voltage buses that are not re-regulated, and that may see large load steps transients.

These applications recommendations are meant as a starting point, with the needs of specific implementations overriding them.

### 8.3.3 N+1 Power Supply – Typical Connection

The N+1 power supply configuration shown in [Figure 9](#) is used where multiple power supplies are paralleled for either higher capacity, redundancy or both. If it takes N supplies to power the load, adding an extra, identical unit in parallel permits the load to continue operation in the event that any one of the N supplies fails. The supplies are ORed together, rather than directly connected to the bus, to isolate the converter output from the bus when it is plugged-in or fails short. The TPS2412/13 with an external MOSFET emulates the function of the ORing diode.

### Feature Description (continued)

It is possible for a malfunctioning converter in an ORed topology to create a bus overvoltage if the loading is less than the converter's capacity (for example,  $N = 1$ ). The ORed topology shown cannot protect the bus from this condition, even if the ORing MOSFET can be turned off. One common solution is to use two MOSFETs in a back-to-back configuration to provide bidirectional blocking. The TPS2412/13 does not have a provision for forcing the gate off when the overvoltage condition occurs, use of the TPS2410/11 is recommended.

ORed supplies are usually designed to share power by various means, although the desired operation could implement an active and standby concept. Sharing approaches include both passive, or voltage drop, and active methods. Not all of the output ORing devices may be ON depending on the sharing control method, bus loading, distribution resistances, and TPS2412/13 settings.

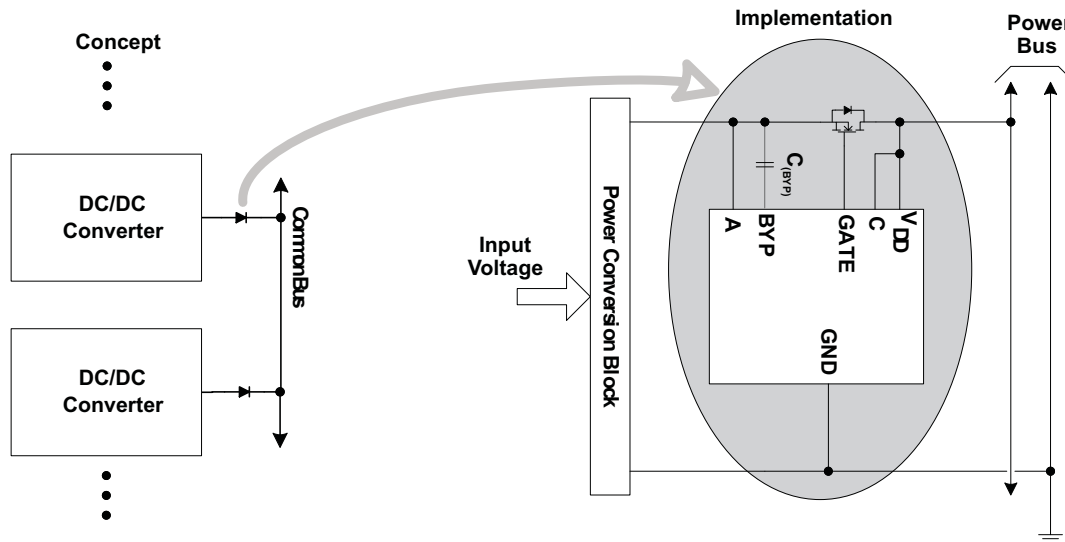

Figure 9. N+1 Power Supply Example

### 8.3.4 Input ORing – Typical Connection

Figure 10 shows how redundant buses may be ORed to a common point to achieve higher reliability. It is possible to have both MOSFETs ON at once if the bus voltages are matched, or the combination of tolerance and regulation causes both TPS2412/13 circuits to see a forward voltage. The ORing MOSFET disconnects the lower-voltage bus, protecting the remaining bus from potential overload by a fault.

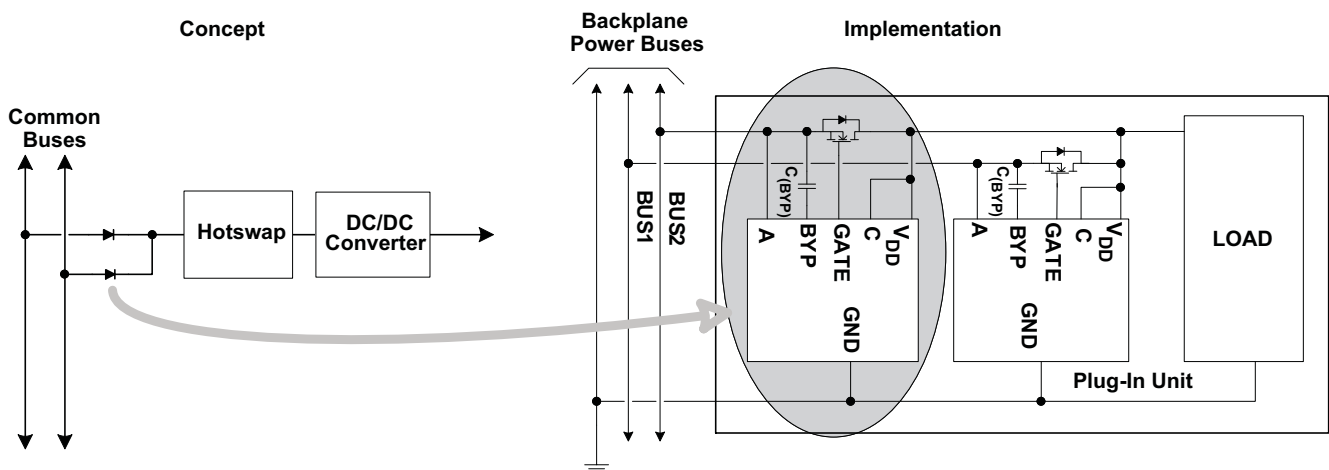

Figure 10. Example ORing of Input Power Buses

## Feature Description (continued)

### 8.3.5 System Design and Behavior With Transients

The power system, perhaps consisting of multiple supplies, interconnections, and loads, is unique for every product. A power distribution has low impedance, and low loss, which yields high Q by its nature. While the addition of lossy capacitors helps at low frequencies, their benefit at high frequencies is compromised by parasitics. Transient events with rise times in the 10 ns range may be caused by inserting or removing units, load fluctuations, switched loads, supply fluctuations, power supply ripple, and shorts. These transients cause the distribution to ring, creating a situation where ORing controllers may trip off unnecessarily. In particular, when an ORing device turns off due to a reverse current fault, there is an abrupt interruption of the current, causing a fast ringing event. Because this ringing occurs at the same point in the topology as the other ORing controllers, they are the most likely to be effected.

The ability to operate in the presence of noise and transients is in direct conflict with the goal of precise ORing with rapid response to actual faults. A fast response reduces peak stress on devices, reduces transients, and promotes un-interrupted system operation. However, a control with small thresholds and high speed is most likely to be falsely tripped by transients that are not the result of a fault. The power distribution system should be designed to control the transient voltages seen by fast-responding devices such as ORing and hotswap devices.

While some applications may find it possible to use RSET to avoid false tripping, the TPS2410/11 provides features beyond the TPS2412/13 including fast-comparator input filtering and STAT to dynamically shift the turnoff threshold.

### 8.3.6 TPS2412 Regulation-Loop Stability

The TPS2412 uses an internal linear error amplifier to keep the external MOSFET from saturating at light load. This feature has the benefits of setting a turnoff above 0 V, providing a soft turnoff for slowly decaying input voltages, and helps droop-sharing redundancy at light load.

Although the control loop has been designed to accommodate a wide range of applications, there are a few guidelines to be followed to assure stability.

- Select a MOSFET  $C_{(ISS)}$  of 1 nF or greater
- Use low ESR bulk capacitors on the output C terminal, typically greater than 100 $\mu$ F with less than 50 m $\Omega$  ESR
- Maintain some minimum operational load (for example, 10 mA or more)

Symptoms of stability issues include  $V_{(AC)}$  undershoot and possible fast turnoff on large-transient recovery, and a worst-case situation where the gate continually cycles on and off. These conditions are solved by following the previous rules. Loop stability should not be confused with tripping the fast comparator due to  $V_{(AC)}$  tripping the gate off.

Although not common, a condition may arise where the DC-DC converter transient response may cause the GATE to cycle on and off at light load. The converter experiences a load spike when GATE transitions from OFF to ON because the ORed bus capacitor voltage charges abruptly by as much as a diode drop. The load spike may cause the supply output to droop and overshoot, which can result in the ORed capacitor peak charging to the overshoot voltage. When the supply output settles to its regulated value, the ORed bus may be higher than the source, causing the TPS2412/13 to turn the GATE off. While this may not actually cause a problem, its occurrence may be mitigated by control of the power supply transient characteristic and increasing its output capacitance while increasing the ORed load to capacitance ratio. Adjusting the TPS2412/13 turnoff threshold to desensitize the redundant ORing device may help as well. Careful attention to layout and charge-pump noise around the TPS2412/13 helps with noise margin.

The linear gate driver has a pullup current of 290  $\mu$ A and pulldown current of 3 mA typical.

### 8.3.7 MOSFET Selection and $R_{(RSET)}$

MOSFET selection criteria include voltage rating, voltage drop, power dissipation, size, and cost. The voltage rating consists of both the ability to withstand the rail voltage with expected transients, and the gate breakdown voltage. The MOSFET gate rating should be the minimum of 12 V, or the controlled rail voltage. Typically this requires a  $\pm 20$ -V GATE voltage rating.

## Feature Description (continued)

While  $r_{DS(on)}$  is often chosen with the power dissipation, voltage drop, size and cost in mind, there are several other factors to be concerned with in ORing applications. When using the TPS2412, the minimum voltage across the device is 10 mV. A device that would have a lower voltage drop at full-load would be overspecified. When using a TPS2413 or TPS2412 with RSET programmed to a negative voltage, the permitted static reverse current is equal to the turnoff threshold divided by the  $r_{DS(on)}$ . While this current may actually be desirable in some systems, the amount may be controlled by selection of  $r_{DS(on)}$  and RSET. The practical range of  $r_{DS(on)}$  for a single MOSFET runs from the low milliohms to 40 m $\Omega$  for a single MOSFET.

MOSFETs may be paralleled for lower voltage drop (power loss) at high current. For TPS2412 operation, one should plan for only one of the MOSFETs to carry current until the 10 mV regulation point is exceeded and the loop forces GATE fully ON. TPS2413 operation does not rely on linear range operation, so the MOSFETs are all ON or OFF together except for short transitional times. Beyond the control issues, current sharing depends on the resistance match including both the  $r_{DS(on)}$  and the connection resistance.

The TPS2412 may be used without a resistor on RSET. In this case, the turnoff  $V_{(AC)}$  threshold is about 3 mV. The TPS2413 may only be operated without an RSET programming resistor if the loading provides a higher  $V_{(AC)}$ . A larger negative turnoff threshold reduces sensitivity to false tripping due to noise on the bus, but permits larger static reverse current. Installing a resistor from RSET to ground creates a negative shift in the fast turnoff threshold per [Equation 2](#).

$$R_{(RSET)} = \left( \frac{-470.02}{V_{(OFF)} - 0.00314} \right) \quad (2)$$

To obtain a –10 mV fast turnoff ( $V_{(A)}$  is less than  $V_{(C)}$  by 10 mV),  $R_{(RSET)} = (-470.02 / (-0.01 - 0.00314)) \approx 35,700\Omega$ . If a 10 m $\Omega$   $r_{DS(on)}$  MOSFET was used, the reverse turnoff current would be calculated using [Equation 3](#).

$$I_{(TURN\_OFF)} = \frac{V_{(THRESHOLD)}}{r_{DS(on)}}$$

$$I_{(TURN\_OFF)} = \frac{-10 \text{ mV}}{10 \text{ m}\Omega}$$

$$I_{(TURN\_OFF)} = -1 \text{ A} \quad (3)$$

The sign indicates that the current is reverse, or flows from the MOSFET drain to source (C to A).

The turnoff speed of a MOSFET is influenced by the effective gate-source and gate-drain capacitance  $C_{ISS}$ . Because these capacitances vary a great deal between different vendor parts and technologies, they should be considered when selecting a MOSFET where the fastest turnoff is desired.

### 8.3.8 Gate Drive, Charge Pump and $C_{(BYP)}$

Gate drive of 270  $\mu$ A typical is generated by an internal charge pump and current limiter. A separate supply,  $V_{DD}$ , is provided to avoid having the large charge pump currents interfere with voltage sensing by the A and C pins. The GATE drive voltage is referenced to  $V_{(A)}$  as GATE will only be driven high when  $V_{(A)} > V_{(C)}$ . The recommended capacitor on BYP (bypass) must be used to form a quiet supply for the internal high-speed comparator.  $V_{(GATE)}$  must not exceed  $V_{(BYP)}$ .

## 8.4 Device Functional Modes

TPS2412 regulates MOSFET  $V_{(AC)}$  to 10 mV linearly while TPS2413 operates in a comparator like manner. Both devices have a programmable ON/OFF threshold.

## 9 Application and Implementation

### NOTE

Information in the following applications sections is not part of the TI component specification, and TI does not warrant its accuracy or completeness. TI's customers are responsible for determining suitability of components for their purposes. Customers should validate and test their design implementation to confirm system functionality.

### 9.1 Application Information

The TPS2412 and TPS2413 are designed to allow output ORing in N+1 power supply applications and input-power bus ORing in redundant source applications. The external MOSFET in conjunction with the TPS2412/13 emulate a discrete diode to perform this unidirectional power combining function.

### 9.2 Typical Application

Applications with the TPS2412/13 are not limited to ORing of identical sections. The TPS2412/13 and external MOSFET form a general purpose function block. [Figure 11](#) shows a circuit with ORing between a discrete diode and a TPS2412/MOSFET section. This circuit can be used to combine two different voltages in cases where the output is regulated, and the additional voltage drop in the Input 1 path is not a concern. An example is ORing of an AC adapter on Input 1 with a lower voltage on Input 2.

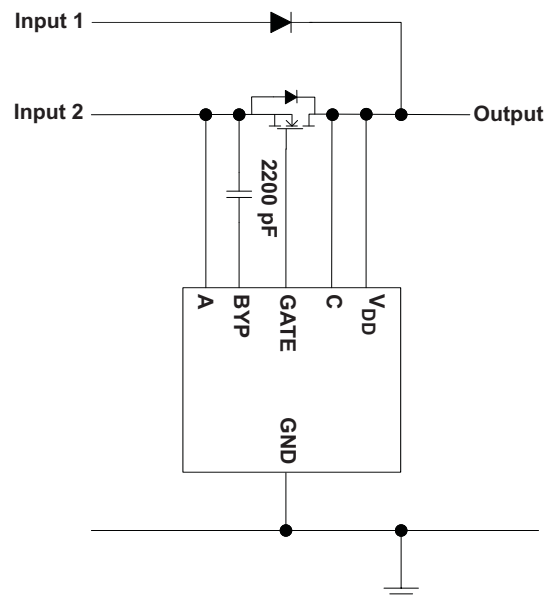

**Figure 11. ORing Circuit**

The TPS2412 may be a better choice in applications where inputs may be removed, causing an open-circuit input. If the MOSFET was ON when the input is removed,  $V_{AC}$  will be virtually zero. If the reverse turnoff threshold is programmed negative, the TPS2412/13 will not pull GATE low. A system interruption could then be created if a short is applied to the floating input. For example, if an AC adapter is first connected to the unit, and then connected to the AC mains, the adapter's output capacitors will look like a momentary short to the unit. A TPS2412 with RSET open will turn the MOSFET OFF when the input goes open circuit.

## Typical Application (continued)

### 9.2.1 Design Requirements

For this design example, use the parameters listed in Table 2 as the input parameters.

Table 2. Design Parameters

DESIGN PARAMETER	EXAMPLE VALUE
Input voltage	12 V
Output voltage	12 V
Load current	5 A

### 9.2.2 Detailed Design Procedure

The following is a summarized design procedure:

1. Choose between the TPS2412 or 2413, see TPS2412 vs TPS2413 – MOSFET Control Methods.
2. Choose the  $V_{DD}$  source. Table 3 provides a guide for where to connect  $V_{DD}$  that covers most cases.  $V_{DD}$  may be directly connected to the supply, but an  $R_{(VDD)}$  and  $C_{(VDD)}$  of 10  $\Omega$  and 0.01  $\mu\text{F}$  is recommended.

Table 3.  $V_{DD}$  Connection Guide

$V_A < 3\text{ V}$	$3\text{ V} \leq V_A \leq 3.6\text{ V}$	$V_A > 3.6\text{ V}$
Bias Supply > 3 V	$V_A$ or Bias Supply > 3 V. $V_C$ if always > 3 V	$V_C$ , $V_A$ , or Bias for special configurations

3. Noise voltage and impedance at the A pin should be kept low.  $C_{(A)}$  may be required if there is noise on the bus, or A is not low impedance. If either of these is a concern, a  $C_{(A)}$  of 0.01  $\mu\text{F}$  or more may be required.
4. Select  $C_{(BYP)}$  as 2200 pF, X7R, 25-V or 50-V ceramic capacitor.
5. Select the MOSFET based on considerations of voltage drop, power dissipated, voltage ratings, and gate capacitance. See sections: MOSFET Selection and RSET and TPS2412 Regulation-Loop Stability.
6. Select  $R_{(RSET)}$  based on which MOSFET was chosen and reverse current considerations – see MOSFET Selection and RSET. If the noise and transient environment is not well known, make provision for  $R_{(RSET)}$  even when using the TPS2412.
7. Make sure to connect RSVD to ground.

### 9.2.3 Application Curves

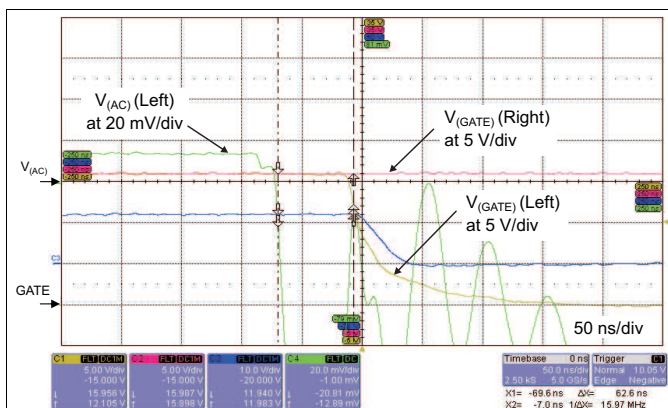

Figure 12. Typical Turnoff With Two ORED Devices Active ( $V_{DD} = 12\text{ V}$ ,  $I_{(LOAD)} = 5\text{ A}$ , IRL3713, Transient Applied to Left Side)

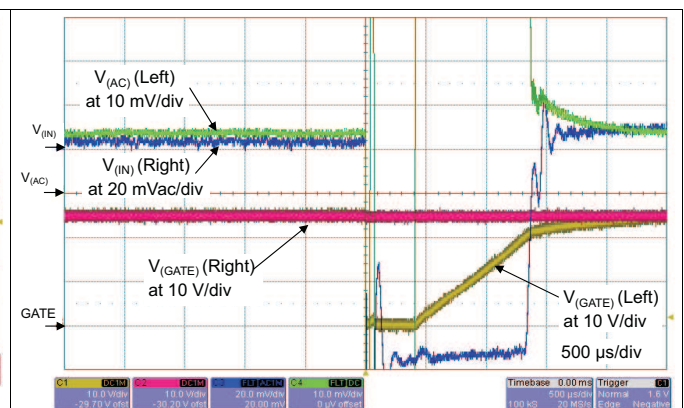

Figure 13. Typical Turnoff And Recovery With Two ORED Devices Active ( $V_{DD} = 3\text{ V}$ ,  $V_A = 18\text{ V}$ ,  $I_{(LOAD)} = 5\text{ A}$ , IRL3713, Transient Applied to Left Side)

## 10 Power Supply Recommendations

### 10.1 Recommended Operating Range

The maximum recommended bus voltage is lower than the absolute maximum voltage ratings on A, C, and  $V_{DD}$  solely to provide some margin for transients on the bus. Most power systems experience transient voltages above the normal operating level. Short transients, or voltage spikes, may be clamped by the ORing MOSFET to an output capacitor and/or voltage rail depending on the system design. Transient protection, for example, a TVS diode (transient voltage suppressor, a type of Zener diode), may be required on the input or output if the system design does not inherently limit transient voltages below the TPS2412/13 absolute maximum ratings. If a TVS is required, it must protect to the absolute maximum ratings at the worst case clamping current. The TPS2412/13 will operate properly up to the absolute maximum voltage ratings on A, C, and  $V_{DD}$ .

### 10.2 $V_{DD}$ , BYP, and Powering Options

The separate  $V_{DD}$  pin provides flexibility for operational power and controlled rail voltage. While the internal UVLO has been set to 2.5 V, the TPS2412/13 requires at least 3 V to generate the specified GATE drive voltage. Sufficient BYP voltage to run internal circuits occurs at  $V_{DD}$  voltages from 2.5 V to 3 V. There are three choices for power, A, C, or a separate supply, two of which are demonstrated in Figure 14. One choice for voltage rails over 3.3 V is to power from C, because it is typically the source of reliable power. Voltage rails below 3.3 V nominal, for example, 2.5 V and below, should use a separate supply such as 5 V. A separate  $V_{DD}$  supply can be used to control voltages above it, for example 5 V powering  $V_{DD}$  to control a 12-V bus.

$V_{DD}$  is the main source of power for the internal control circuits. The charge pump that powers BYP draws most of its power from  $V_{DD}$ . The input should be low impedance, making a bypass capacitor a preferred solution. A 10- $\Omega$  series resistor may be used to limit inrush current into the bypass capacitor, and to provide noise filtering for the supply.

BYP is the interconnection point between a charge pump,  $V_{(AC)}$  monitor amplifiers and comparators, and the gate driver.  $C_{(BYP)}$  must be used to filter the charge pump. A 2200 pF is recommended, but the value is not critical.

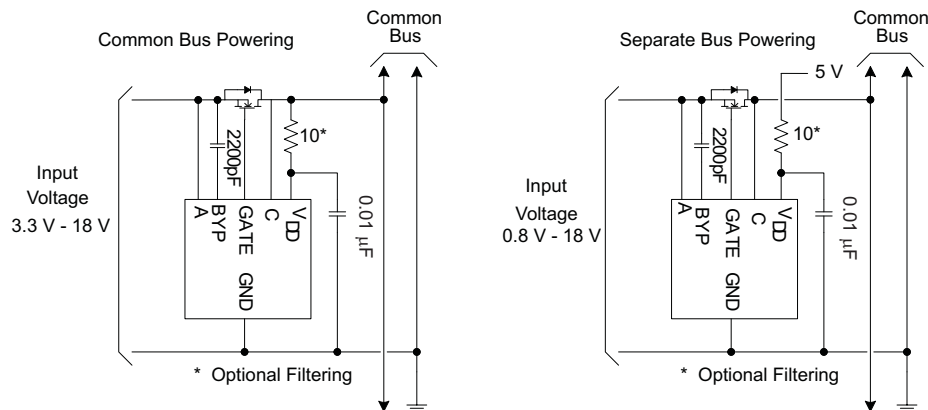

**Figure 14.  $V_{DD}$  Powering Examples**

## 11 Layout

### 11.1 Layout Guidelines

1. The TPS2412/13, MOSFET, and associated components should be used over a ground plane.
2. The GND connection should be short, with multiple vias to ground.
3.  $C_{(VDD)}$  should be adjacent to the  $V_{DD}$  pin with a minimal ground connection length to the plane.
4. The GATE connection should be short and wide (for example, 0.025" minimum).
5. The C pin should be Kelvin connected to the MOSFET.
6. The A pin should be a short, wide, Kelvin connection to the MOSFET.
7.  $R_{(SET)}$  should be kept immediately adjacent to the TPS2412/13 with short leads.
8.  $C_{(BYP)}$  should be kept immediately adjacent to the TPS2412/13 with short leads.



## 12 Device and Documentation Support

### 12.1 Related Links

The table below lists quick access links. Categories include technical documents, support and community resources, tools and software, and quick access to sample or buy.

**Table 4. Related Links**

PARTS	PRODUCT FOLDER	SAMPLE & BUY	TECHNICAL DOCUMENTS	TOOLS & SOFTWARE	SUPPORT & COMMUNITY
TPS2412	<a href="#">Click here</a>	<a href="#">Click here</a>	<a href="#">Click here</a>	<a href="#">Click here</a>	<a href="#">Click here</a>
TPS2413	<a href="#">Click here</a>	<a href="#">Click here</a>	<a href="#">Click here</a>	<a href="#">Click here</a>	<a href="#">Click here</a>

### 12.2 Community Resources

TI E2E™ [support forums](#) are an engineer's go-to source for fast, verified answers and design help — straight from the experts. Search existing answers or ask your own question to get the quick design help you need.

Linked content is provided "AS IS" by the respective contributors. They do not constitute TI specifications and do not necessarily reflect TI's views; see TI's [Terms of Use](#).

### 12.3 Trademarks

E2E is a trademark of Texas Instruments.  
All other trademarks are the property of their respective owners.

### 12.4 Electrostatic Discharge Caution



These devices have limited built-in ESD protection. The leads should be shorted together or the device placed in conductive foam during storage or handling to prevent electrostatic damage to the MOS gates.

### 12.5 Glossary

[SLYZ022](#) — *TI Glossary*.

This glossary lists and explains terms, acronyms, and definitions.

## 13 Mechanical, Packaging, and Orderable Information

The following pages include mechanical, packaging, and orderable information. This information is the most current data available for the designated devices. This data is subject to change without notice and revision of this document. For browser-based versions of this data sheet, refer to the left-hand navigation.

**PACKAGING INFORMATION**

Orderable Device	Status (1)	Package Type	Package Drawing	Pins	Package Qty	Eco Plan (2)	Lead finish/ Ball material (6)	MSL Peak Temp (3)	Op Temp (°C)	Device Marking (4/5)	Samples
TPS2412D	ACTIVE	SOIC	D	8	75	RoHS & Green	NIPDAU	Level-1-260C-UNLIM	-40 to 85	2412D	<a href="#">Samples</a>
TPS2412DR	ACTIVE	SOIC	D	8	2500	RoHS & Green	NIPDAU	Level-1-260C-UNLIM	-40 to 85	2412D	<a href="#">Samples</a>
TPS2412DRG4	ACTIVE	SOIC	D	8	2500	RoHS & Green	NIPDAU	Level-1-260C-UNLIM	-40 to 85	2412D	<a href="#">Samples</a>
TPS2412PW	ACTIVE	TSSOP	PW	8	150	RoHS & Green	NIPDAU	Level-1-260C-UNLIM	-40 to 85	2412	<a href="#">Samples</a>
TPS2412PWR	ACTIVE	TSSOP	PW	8	2000	RoHS & Green	NIPDAU	Level-1-260C-UNLIM	-40 to 85	2412	<a href="#">Samples</a>
TPS2412PWRG4	ACTIVE	TSSOP	PW	8	2000	RoHS & Green	NIPDAU	Level-1-260C-UNLIM	-40 to 85	2412	<a href="#">Samples</a>
TPS2413D	ACTIVE	SOIC	D	8	75	RoHS & Green	NIPDAU	Level-1-260C-UNLIM	-40 to 85	2413D	<a href="#">Samples</a>
TPS2413DR	ACTIVE	SOIC	D	8	2500	RoHS & Green	NIPDAU	Level-1-260C-UNLIM	-40 to 85	2413D	<a href="#">Samples</a>
TPS2413PW	ACTIVE	TSSOP	PW	8	150	RoHS & Green	NIPDAU	Level-1-260C-UNLIM	-40 to 85	2413	<a href="#">Samples</a>
TPS2413PWR	ACTIVE	TSSOP	PW	8	2000	RoHS & Green	NIPDAU	Level-1-260C-UNLIM	-40 to 85	2413	<a href="#">Samples</a>

(1) The marketing status values are defined as follows:

**ACTIVE:** Product device recommended for new designs.

**LIFEBUY:** TI has announced that the device will be discontinued, and a lifetime-buy period is in effect.

**NRND:** Not recommended for new designs. Device is in production to support existing customers, but TI does not recommend using this part in a new design.

**PREVIEW:** Device has been announced but is not in production. Samples may or may not be available.

**OBSOLETE:** TI has discontinued the production of the device.

(2) **RoHS:** TI defines "RoHS" to mean semiconductor products that are compliant with the current EU RoHS requirements for all 10 RoHS substances, including the requirement that RoHS substance do not exceed 0.1% by weight in homogeneous materials. Where designed to be soldered at high temperatures, "RoHS" products are suitable for use in specified lead-free processes. TI may reference these types of products as "Pb-Free".

**RoHS Exempt:** TI defines "RoHS Exempt" to mean products that contain lead but are compliant with EU RoHS pursuant to a specific EU RoHS exemption.

**Green:** TI defines "Green" to mean the content of Chlorine (Cl) and Bromine (Br) based flame retardants meet JS709B low halogen requirements of <=1000ppm threshold. Antimony trioxide based flame retardants must also meet the <=1000ppm threshold requirement.

(3) MSL, Peak Temp. - The Moisture Sensitivity Level rating according to the JEDEC industry standard classifications, and peak solder temperature.

(4) There may be additional marking, which relates to the logo, the lot trace code information, or the environmental category on the device.

<sup>(5)</sup> Multiple Device Markings will be inside parentheses. Only one Device Marking contained in parentheses and separated by a "~" will appear on a device. If a line is indented then it is a continuation of the previous line and the two combined represent the entire Device Marking for that device.

<sup>(6)</sup> Lead finish/Ball material - Orderable Devices may have multiple material finish options. Finish options are separated by a vertical ruled line. Lead finish/Ball material values may wrap to two lines if the finish value exceeds the maximum column width.

**Important Information and Disclaimer:**The information provided on this page represents TI's knowledge and belief as of the date that it is provided. TI bases its knowledge and belief on information provided by third parties, and makes no representation or warranty as to the accuracy of such information. Efforts are underway to better integrate information from third parties. TI has taken and continues to take reasonable steps to provide representative and accurate information but may not have conducted destructive testing or chemical analysis on incoming materials and chemicals. TI and TI suppliers consider certain information to be proprietary, and thus CAS numbers and other limited information may not be available for release.

In no event shall TI's liability arising out of such information exceed the total purchase price of the TI part(s) at issue in this document sold by TI to Customer on an annual basis.

**TAPE AND REEL INFORMATION**

**QUADRANT ASSIGNMENTS FOR PIN 1 ORIENTATION IN TAPE**

\*All dimensions are nominal

Device	Package Type	Package Drawing	Pins	SPQ	Reel Diameter (mm)	Reel Width W1 (mm)	A0 (mm)	B0 (mm)	K0 (mm)	P1 (mm)	W (mm)	Pin1 Quadrant
TPS2412DR	SOIC	D	8	2500	330.0	12.4	6.4	5.2	2.1	8.0	12.0	Q1
TPS2412PWR	TSSOP	PW	8	2000	330.0	12.4	7.0	3.6	1.6	8.0	12.0	Q1
TPS2413DR	SOIC	D	8	2500	330.0	12.4	6.4	5.2	2.1	8.0	12.0	Q1
TPS2413PWR	TSSOP	PW	8	2000	330.0	12.4	7.0	3.6	1.6	8.0	12.0	Q1

**TAPE AND REEL BOX DIMENSIONS**

\*All dimensions are nominal

Device	Package Type	Package Drawing	Pins	SPQ	Length (mm)	Width (mm)	Height (mm)
TPS2412DR	SOIC	D	8	2500	340.5	338.1	20.6
TPS2412PWR	TSSOP	PW	8	2000	356.0	356.0	35.0
TPS2413DR	SOIC	D	8	2500	340.5	338.1	20.6
TPS2413PWR	TSSOP	PW	8	2000	356.0	356.0	35.0

**TUBE**

\*All dimensions are nominal

Device	Package Name	Package Type	Pins	SPQ	L (mm)	W (mm)	T (μm)	B (mm)
TPS2412D	D	SOIC	8	75	507	8	3940	4.32
TPS2412PW	PW	TSSOP	8	150	530	10.2	3600	3.5
TPS2413D	D	SOIC	8	75	507	8	3940	4.32
TPS2413PW	PW	TSSOP	8	150	530	10.2	3600	3.5



D0008A

# PACKAGE OUTLINE

SOIC - 1.75 mm max height

SMALL OUTLINE INTEGRATED CIRCUIT



NOTES:

1. Linear dimensions are in inches [millimeters]. Dimensions in parenthesis are for reference only. Controlling dimensions are in inches. Dimensioning and tolerancing per ASME Y14.5M.
2. This drawing is subject to change without notice.
3. This dimension does not include mold flash, protrusions, or gate burrs. Mold flash, protrusions, or gate burrs shall not exceed  $.006$  [0.15] per side.
4. This dimension does not include interlead flash.
5. Reference JEDEC registration MS-012, variation AA.

# EXAMPLE BOARD LAYOUT

D0008A

SOIC - 1.75 mm max height

SMALL OUTLINE INTEGRATED CIRCUIT



LAND PATTERN EXAMPLE  
 EXPOSED METAL SHOWN  
 SCALE:8X



SOLDER MASK DETAILS

4214825/C 02/2019

NOTES: (continued)

- 6. Publication IPC-7351 may have alternate designs.
- 7. Solder mask tolerances between and around signal pads can vary based on board fabrication site.

# EXAMPLE STENCIL DESIGN

D0008A

SOIC - 1.75 mm max height

SMALL OUTLINE INTEGRATED CIRCUIT



SOLDER PASTE EXAMPLE  
BASED ON .005 INCH [0.125 MM] THICK STENCIL  
SCALE:8X

4214825/C 02/2019

NOTES: (continued)

8. Laser cutting apertures with trapezoidal walls and rounded corners may offer better paste release. IPC-7525 may have alternate design recommendations.
9. Board assembly site may have different recommendations for stencil design.

PW0008A



PACKAGE OUTLINE  
TSSOP - 1.2 mm max height

SMALL OUTLINE PACKAGE

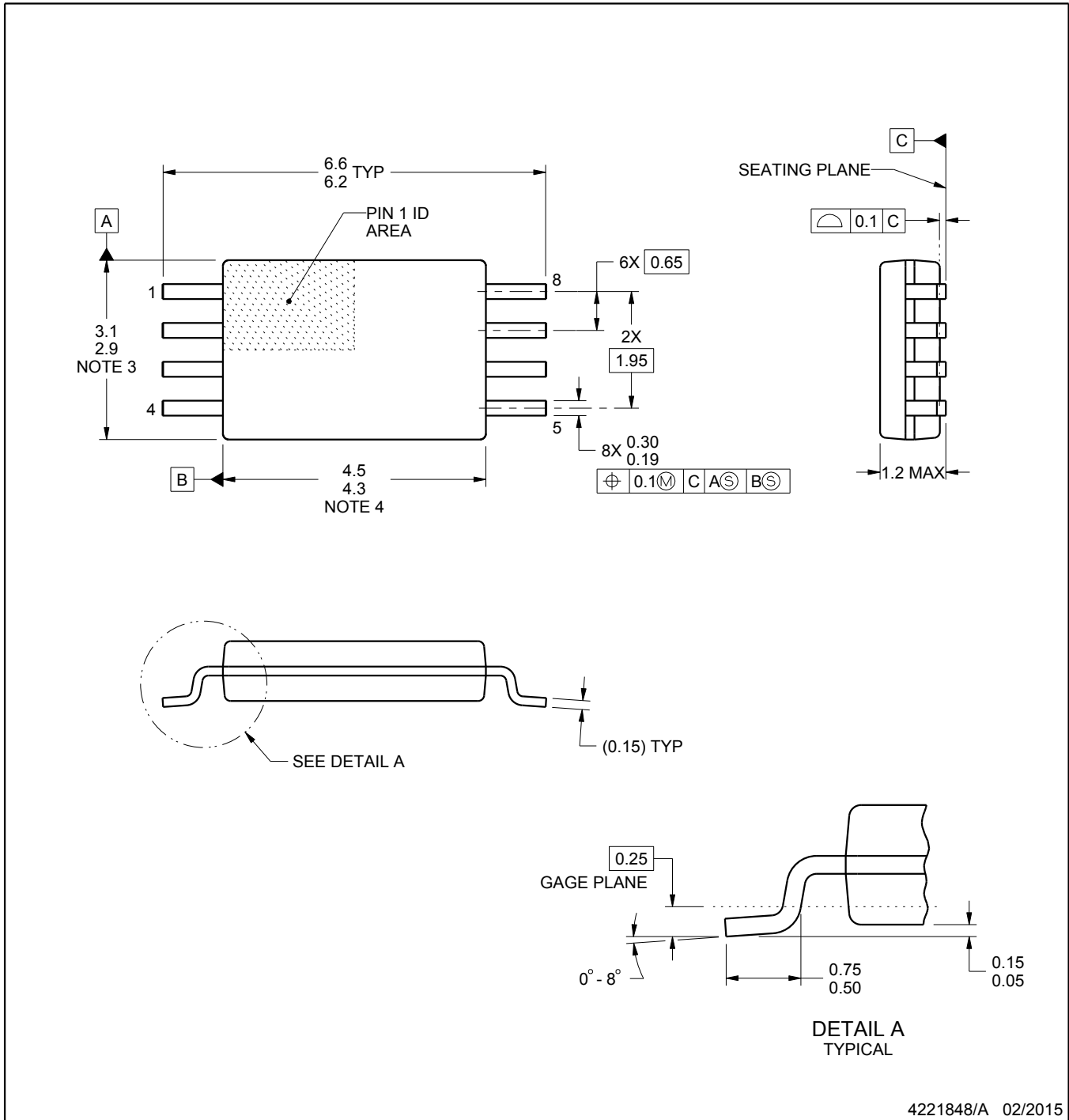

4221848/A 02/2015

NOTES:

1. All linear dimensions are in millimeters. Any dimensions in parenthesis are for reference only. Dimensioning and tolerancing per ASME Y14.5M.
2. This drawing is subject to change without notice.
3. This dimension does not include mold flash, protrusions, or gate burrs. Mold flash, protrusions, or gate burrs shall not exceed 0.15 mm per side.
4. This dimension does not include interlead flash. Interlead flash shall not exceed 0.25 mm per side.
5. Reference JEDEC registration MO-153, variation AA.

# EXAMPLE BOARD LAYOUT

PW0008A

TSSOP - 1.2 mm max height

SMALL OUTLINE PACKAGE

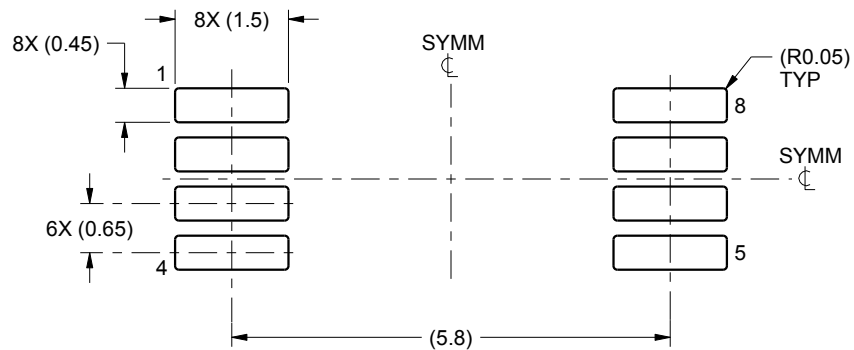

LAND PATTERN EXAMPLE  
SCALE:10X



SOLDER MASK DETAILS  
NOT TO SCALE

4221848/A 02/2015

NOTES: (continued)

- 6. Publication IPC-7351 may have alternate designs.
- 7. Solder mask tolerances between and around signal pads can vary based on board fabrication site.

# EXAMPLE STENCIL DESIGN

PW0008A

TSSOP - 1.2 mm max height

SMALL OUTLINE PACKAGE

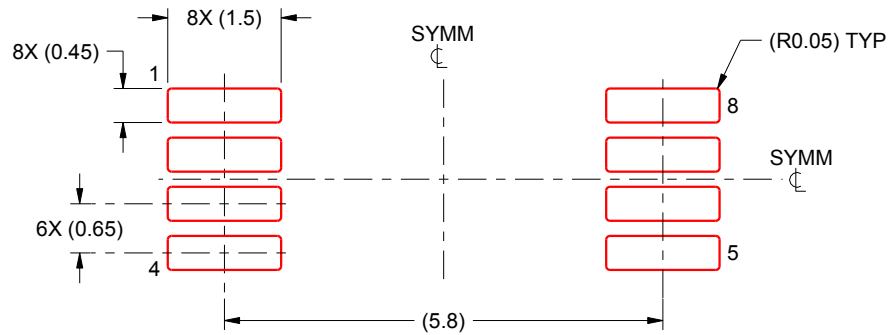

SOLDER PASTE EXAMPLE  
BASED ON 0.125 mm THICK STENCIL  
SCALE:10X

4221848/A 02/2015

NOTES: (continued)

8. Laser cutting apertures with trapezoidal walls and rounded corners may offer better paste release. IPC-7525 may have alternate design recommendations.
9. Board assembly site may have different recommendations for stencil design.

## IMPORTANT NOTICE AND DISCLAIMER

TI PROVIDES TECHNICAL AND RELIABILITY DATA (INCLUDING DATA SHEETS), DESIGN RESOURCES (INCLUDING REFERENCE DESIGNS), APPLICATION OR OTHER DESIGN ADVICE, WEB TOOLS, SAFETY INFORMATION, AND OTHER RESOURCES "AS IS" AND WITH ALL FAULTS, AND DISCLAIMS ALL WARRANTIES, EXPRESS AND IMPLIED, INCLUDING WITHOUT LIMITATION ANY IMPLIED WARRANTIES OF MERCHANTABILITY, FITNESS FOR A PARTICULAR PURPOSE OR NON-INFRINGEMENT OF THIRD PARTY INTELLECTUAL PROPERTY RIGHTS.

These resources are intended for skilled developers designing with TI products. You are solely responsible for (1) selecting the appropriate TI products for your application, (2) designing, validating and testing your application, and (3) ensuring your application meets applicable standards, and any other safety, security, regulatory or other requirements.

These resources are subject to change without notice. TI grants you permission to use these resources only for development of an application that uses the TI products described in the resource. Other reproduction and display of these resources is prohibited. No license is granted to any other TI intellectual property right or to any third party intellectual property right. TI disclaims responsibility for, and you will fully indemnify TI and its representatives against, any claims, damages, costs, losses, and liabilities arising out of your use of these resources.

TI's products are provided subject to [TI's Terms of Sale](#) or other applicable terms available either on [ti.com](https://www.ti.com) or provided in conjunction with such TI products. TI's provision of these resources does not expand or otherwise alter TI's applicable warranties or warranty disclaimers for TI products.

TI objects to and rejects any additional or different terms you may have proposed.

Mailing Address: Texas Instruments, Post Office Box 655303, Dallas, Texas 75265  
Copyright © 2023, Texas Instruments Incorporated

## Looking for pricing, stock, or lifecycle information?

Click below to explore more details on WIN SOURCE:

 [View TPS2413DR on WIN SOURCE](#)

 [Texas Instruments](#) Information

## Optimize Your Supply Chain with WIN SOURCE Solutions

-  Global Sourcing Solution
-  Obsolete Management
-  Cost Control Management
-  Shortage Management
-  Alternative Solution
-  Excess Inventory Management