



**THE DATASHEET OF
TPS3808G01MDBVTEP**



TPS3808-EP Low Quiescent Current, Programmable Delay Supervisory Circuit

1 Features

- Controlled Baseline
 - One Assembly Site
 - One Test Site
 - One Fabrication Site
- Extended Temperature Performance of -55°C to 125°C
- Enhanced Diminishing Manufacturing Sources (DMS) Support
- Enhanced Product-Change Notification
- Qualification Pedigree ⁽¹⁾
- Power-On Reset Generator With Adjustable Delay Time: 1.25 ms to 10 s
- Very Low Quiescent Current: 2.4 μA Typical
- High Threshold Accuracy: 0.5% Typical
- Fixed Threshold Voltages for Standard Voltage Rails From 0.9 V to 5 V and Adjustable Voltage Down to 0.4 V Are Available
- Manual Reset ($\overline{\text{MR}}$) Input
- Open-Drain $\overline{\text{RESET}}$ Output
- Temperature Range: -55°C to 125°C
- Small SOT-23 Package

- (1) Component qualification in accordance with JEDEC and industry standards to ensure reliable operation over an extended temperature range. This includes, but is not limited to, Highly Accelerated Stress Test (HAST) or biased 85/85, temperature cycle, autoclave or unbiased HAST, electromigration, bond intermetallic life, and mold compound life. Such qualification testing should not be viewed as justifying use of this component beyond specified performance and environmental limits.

2 Applications

- DSP or Microcontroller Applications
- Notebook/Desktop Computers
- PDAs and Hand-Held Products
- Portable and Battery Powered Products
- FPGA and ASIC Applications

3 Description

The TPS3808xxx family of microprocessor supervisory circuits monitors system voltages from 0.4 V to 5.0 V, asserting an open-drain $\overline{\text{RESET}}$ signal when the SENSE voltage drops below a preset threshold or when the manual reset ($\overline{\text{MR}}$) pin drops to a logic low. The $\overline{\text{RESET}}$ output remains low for the user-adjustable delay time after the SENSE voltage and manual reset ($\overline{\text{MR}}$) return above the respective thresholds.

The TPS3808 uses a precision reference to achieve 0.5% threshold accuracy for $V_{\text{IT}} \leq 3.3$ V. The reset delay time can be set to 20 ms by disconnecting the C_{T} pin, 300 ms by connecting the C_{T} pin to V_{DD} using a resistor, or can be user-adjusted between 1.25 ms and 10 s by connecting the C_{T} pin to an external capacitor. The TPS3808 has a very low typical quiescent current of 2.4 μA , so it is well-suited to battery-powered applications. It is available in a small SOT-23 package, and is fully specified over a temperature range of -55°C to $+125^{\circ}\text{C}$ (T_{J}).

Device Information⁽¹⁾

PART NUMBER	PACKAGE	BODY SIZE (NOM)
TPS3808-EP	SOT (6)	2.90 mm x 1.60 mm

- (1) For all available packages, see the orderable addendum at the end of the datasheet.

Typical Application Circuit

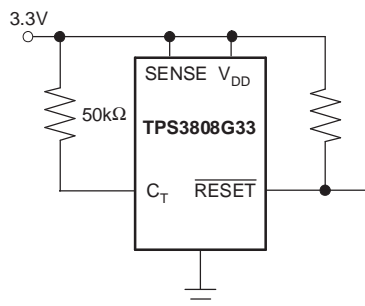

300ms Delay

(a)

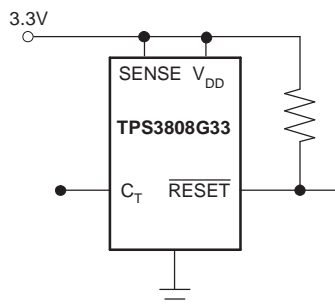

20ms Delay

(b)

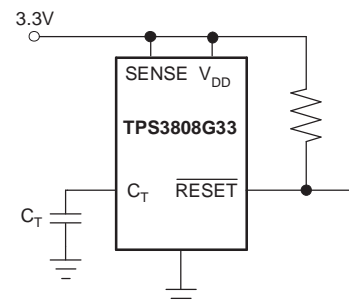

$$\text{Delay (s)} = \frac{C_{\text{T}} (\text{nF})}{175} + 0.5 \times 10^{-3} (\text{s})$$

(c)



Table of Contents

1 Features	1	7.2 Functional Block Diagrams	9
2 Applications	1	7.3 Feature Description	9
3 Description	1	7.4 Device Functional Modes	9
4 Revision History	2	8 Application and Implementation	10
5 Pin Configuration and Functions	3	8.1 Application Information	10
6 Specifications	4	8.2 Typical Application	13
6.1 Absolute Maximum Ratings	4	9 Power Supply Recommendations	15
6.2 ESD Ratings	4	10 Layout	15
6.3 Recommended Operating Conditions	4	10.1 Layout Guidelines	15
6.4 Thermal Information	4	10.2 Layout Example	15
6.5 Electrical Characteristics	5	11 Device and Documentation Support	16
6.6 Switching Characteristics	5	11.1 Trademarks	16
6.7 Typical Characteristics	7	11.2 Electrostatic Discharge Caution	16
7 Detailed Description	9	11.3 Glossary	16
7.1 Overview	9	12 Mechanical, Packaging, and Orderable Information	16

4 Revision History

Changes from Revision C (September 2008) to Revision D	Page
<ul style="list-style-type: none"> Added <i>ESD Ratings</i> table, <i>Feature Description</i> section, <i>Device Functional Modes</i>, <i>Application and Implementation</i> section, <i>Power Supply Recommendations</i> section, <i>Layout</i> section, <i>Device and Documentation Support</i> section, and <i>Mechanical, Packaging, and Orderable Information</i> section 	4

5 Pin Configuration and Functions

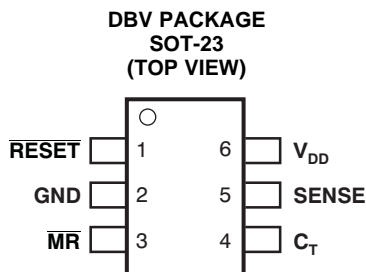

Pin Functions

PIN		I/O	DESCRIPTION
NAME	NO.		
$\overline{\text{RESET}}$	1	O	$\overline{\text{RESET}}$ is an open-drain output that is driven to a low impedance state when $\overline{\text{RESET}}$ is asserted (either the SENSE input is lower than the threshold voltage (V_{IT}) or the $\overline{\text{MR}}$ pin is set to a logic low). $\overline{\text{RESET}}$ remains low (asserted) for the reset period after both SENSE is above V_{IT} and $\overline{\text{MR}}$ is set to a logic high. A pullup resistor from 10 k Ω to 1 M Ω should be used on this pin, and allows the reset pin to attain voltages higher than V_{DD} .
GND	2	—	Ground
$\overline{\text{MR}}$	3	I	Driving the manual reset pin ($\overline{\text{MR}}$) low asserts $\overline{\text{RESET}}$. $\overline{\text{MR}}$ is internally tied to V_{DD} by a 90k Ω pullup resistor.
C_T	4	I	Reset period programming pin. Connecting this pin to V_{DD} through a 40-k Ω to 200-k Ω resistor or leaving it open results in fixed delay times (see Switching Characteristics). Connecting this pin to a ground referenced capacitor ≥ 100 pF gives a user-programmable delay time. See the Selecting the Reset Delay Time section for more information.
SENSE	5	I	This pin is connected to the voltage to be monitored. If the voltage at this terminal drops below the threshold voltage V_{IT} , then $\overline{\text{RESET}}$ is asserted.
V_{DD}	6	I	Supply voltage. It is good analog design practice to place a 0.1- μ F ceramic capacitor close to this pin.

6 Specifications

6.1 Absolute Maximum Ratings

Over operating junction temperature range, unless otherwise noted.⁽¹⁾

	MIN	MAX	UNIT
Input voltage, V_{DD}	-0.3	7.0	V
C_T voltage, V_{CT}	-0.3	$V_{DD} + 0.3$	
Other voltage: V_{RESET} , V_{MR} , V_{SENSE}	-0.3	7	
\overline{RESET} pin current		5	mA
Operating junction temperature, T_J ⁽²⁾	-55	150	°C
Storage temperature, T_{stg}	-65	150	

- (1) Stresses beyond those listed under *Absolute Maximum Ratings* may cause permanent damage to the device. These are stress ratings only, which do not imply functional operation of the device at these or any other conditions beyond those indicated under *Recommended Operating Conditions*. Exposure to absolute-maximum-rated conditions for extended periods may affect device reliability.
- (2) As a result of the low dissipated power in this device, it is assumed that $T_J = T_A$.

6.2 ESD Ratings

		VALUE	UNIT
$V_{(ESD)}$ Electrostatic discharge	Human body model (HBM), per ANSI/ESDA/JEDEC JS-001, all pins ⁽¹⁾	±3000	V
	Charged device model (CDM), per JEDEC specification JESD22-C101, all pins ⁽²⁾	±1000	

- (1) JEDEC document JEP155 states that 500-V HBM allows safe manufacturing with a standard ESD control process.
- (2) JEDEC document JEP157 states that 250-V CDM allows safe manufacturing with a standard ESD control process.

6.3 Recommended Operating Conditions

over operating free-air temperature range (unless otherwise noted)

		MIN	NOM	MAX	UNIT
V_{DD}	Input supply range	1.7		6.5	V
Power-up reset voltage	$V_{OL}(\max) = 0.2\text{ V}$, $I_{\overline{RESET}} = 15\ \mu\text{A}$			0.8	V

6.4 Thermal Information

THERMAL METRIC ⁽¹⁾		TPS3808-EP	UNIT
		DBV	
		6 PINS	
$R_{\theta JA}$	Junction-to-ambient thermal resistance	180.9	°C/W
$R_{\theta JC(\text{top})}$	Junction-to-case (top) thermal resistance	117.8	
$R_{\theta JB}$	Junction-to-board thermal resistance	27.8	
Ψ_{JT}	Junction-to-top characterization parameter	1.12	
Ψ_{JB}	Junction-to-board characterization parameter	27.3	

- (1) For more information about traditional and new thermal metrics, see the *IC Package Thermal Metrics* application report, [SPRA953](#).

6.5 Electrical Characteristics

1.7 V ≤ V_{DD} ≤ 6.5 V, R_{LRESET} = 100 kΩ, C_{LRESET} = 50 pF, over operating temperature range (T_J = –55°C to +125°C), unless otherwise noted. Typical values are at T_J = +25°C.

PARAMETER		TEST CONDITIONS	MIN	TYP	MAX	UNIT	
V _{DD}	Input supply range		1.7		6.5	V	
I _{DD}	Supply current (current into V _{DD} pin)	V _{DD} = 3.3 V, $\overline{\text{RESET}}$ not asserted MR, $\overline{\text{RESET}}$, C _T open		2.4	5.0	μA	
		V _{DD} = 6.5 V, $\overline{\text{RESET}}$ not asserted MR, $\overline{\text{RESET}}$, C _T open		2.7	6.0		
V _{OL}	Low-level output voltage	1.3 V ≤ V _{DD} < 1.8 V, I _{OL} = 0.4 mA			0.3	V	
		1.8 V ≤ V _{DD} ≤ 6.5 V, I _{OL} = 1.0 mA			0.4		
	Power-up reset voltage ⁽¹⁾	V _{OL} (max) = 0.2 V, I $\overline{\text{RESET}}$ = 15 μA			0.8		
V _{IT}	Negative-going input threshold accuracy	TPS3808G01		–2.0%	±1.0%	+2.0%	
		V _{IT} ≤ 3.3 V		–1.7%	±0.5%	+1.7%	
		3.3 V < V _{IT} ≤ 5.0 V		–2.0%	±1.0%	+2.0%	
V _{HYS}	Hysteresis on V _{IT} pin	TPS3808G01			1.5%	3.0%	
		Fixed versions			1.0%	2.5%	
R $\overline{\text{MR}}$	$\overline{\text{MR}}$ Internal pullup resistance		70	90		kΩ	
I _{SENSE}	Input current at SENSE pin	TPS3808G01	V _{SENSE} = V _{IT}	–25		25	nA
		Fixed versions	V _{SENSE} = 6.5 V		1.7		μA
I _{OH}	$\overline{\text{RESET}}$ leakage current	V $\overline{\text{RESET}}$ = 6.5 V, $\overline{\text{RESET}}$ not asserted			300	nA	
C _{IN}	Input capacitance, any pin	C _T pin	V _{IN} = 0 V to V _{DD}		5	pF	
		Other pins	V _{IN} = 0 V to 6.5 V		5		
V _{IL}	$\overline{\text{MR}}$ logic low input		0		0.3 V _{DD}	V	
V _{IH}	$\overline{\text{MR}}$ logic high input		0.7 V _{DD}		V _{DD}		
θ _{JA}	Thermal resistance, junction-to-ambient			290		°C/W	

(1) The lowest supply voltage (V_{DD}) at which $\overline{\text{RESET}}$ becomes active. T_{rise(VDD)} ≥ 15 μs/V.

6.6 Switching Characteristics

1.7 V ≤ V_{DD} ≤ 6.5 V, R_{LRESET} = 100 kΩ, C_{LRESET} = 50 pF, over operating temperature range (T_J = –55°C to +125°C), unless otherwise noted. Typical values are at T_J = +25°C.

PARAMETER		TEST CONDITIONS	MIN	TYP	MAX	UNIT		
t _w	Input pulse width to $\overline{\text{RESET}}$	SENSE	V _{IH} = 1.05 V _{IT} , V _{IL} = 0.95 V _{IT}		20	μs		
		$\overline{\text{MR}}$	V _{IH} = 0.7 V _{DD} , V _{IL} = 0.3 V _{DD}		0.00 1			
t _d	$\overline{\text{RESET}}$ delay time	C _T = Open	See Timing Diagram		12	20	29	ms
		C _T = V _{DD}			180	300	440	
		C _T = 100 pF			0.75	1.25	1.8	s
		C _T = 180 nF			0.7	1.2	1.8	
t _{pHL}	Propagation delay	$\overline{\text{MR}}$ to $\overline{\text{RESET}}$	V _{IH} = 0.7 V _{DD} , V _{IL} = 0.3 V _{DD}		150		ns	
	High-to-low level $\overline{\text{RESET}}$ delay	SENSE to $\overline{\text{RESET}}$	V _{IH} = 1.05 V _{IT} , V _{IL} = 0.95 V _{IT}		20		μs	

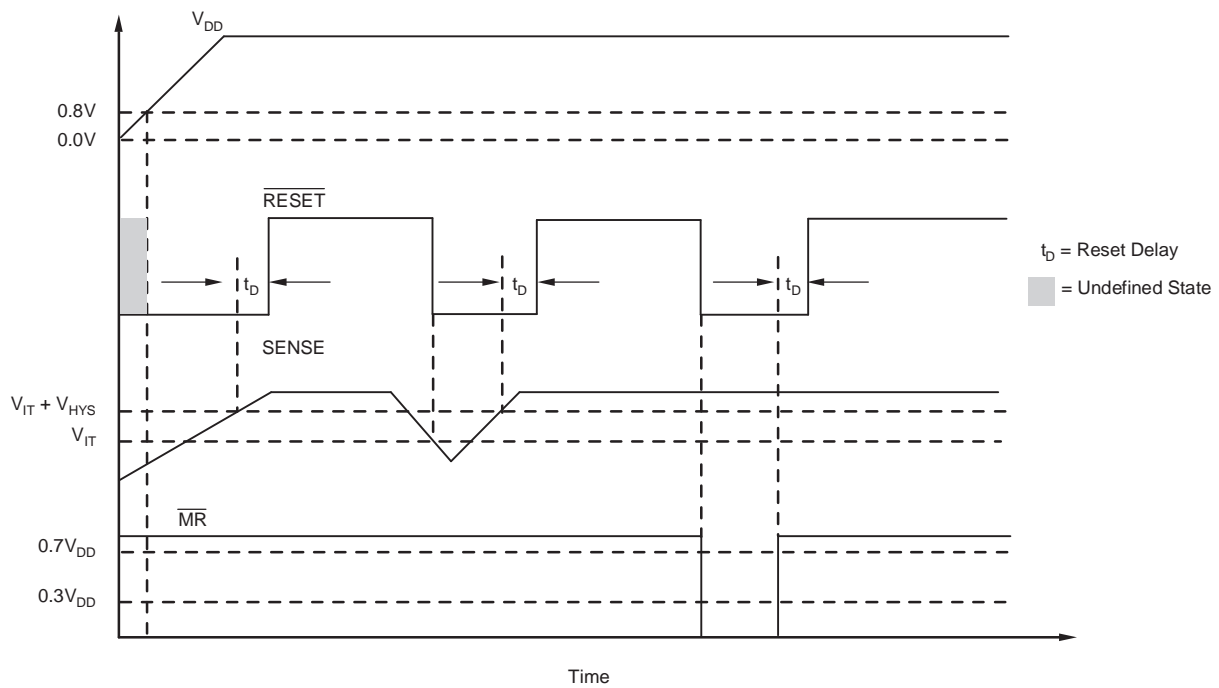

Figure 1. TPS3808 Timing Diagram Showing \overline{MR} and SENSE Reset Timing

Table 1. Truth Table

\overline{MR}	SENSE > V_{IT}	\overline{RESET}
L	0	L
L	1	L
H	0	L
H	1	H

6.7 Typical Characteristics

At $T_J = +25^\circ\text{C}$, $V_{DD} = 3.3\text{ V}$, $R_{L\text{RESET}} = 100\text{k}\Omega$, and $C_{L\text{RESET}} = 50\text{pF}$, unless otherwise noted.

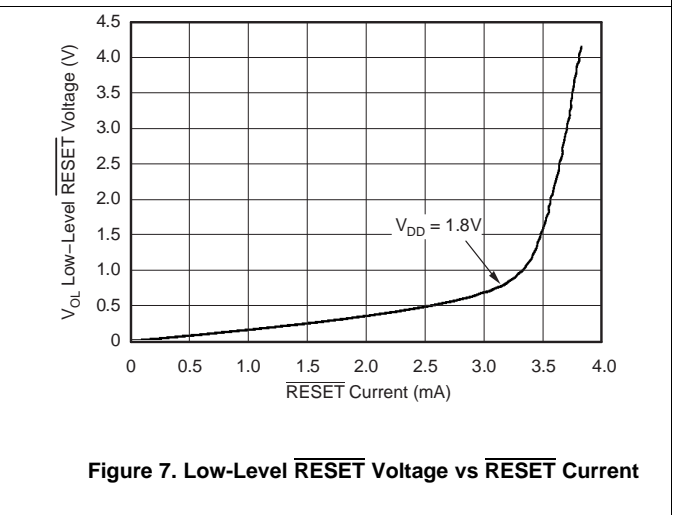
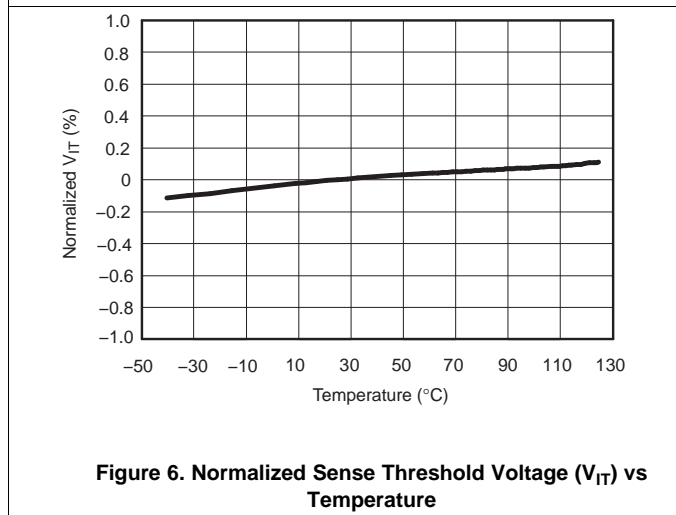
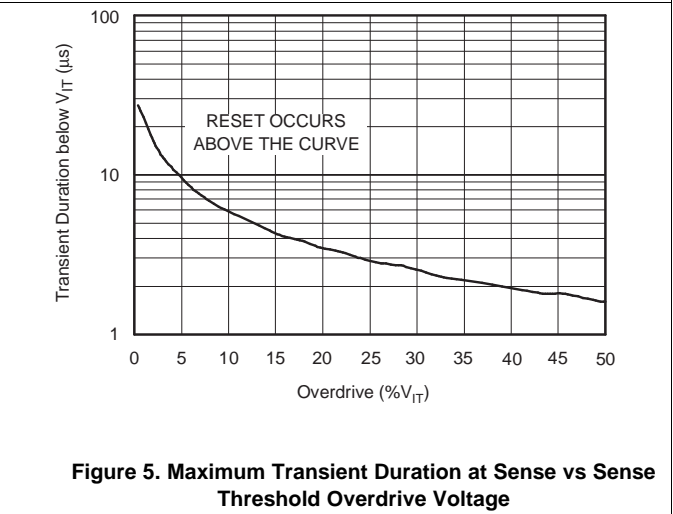
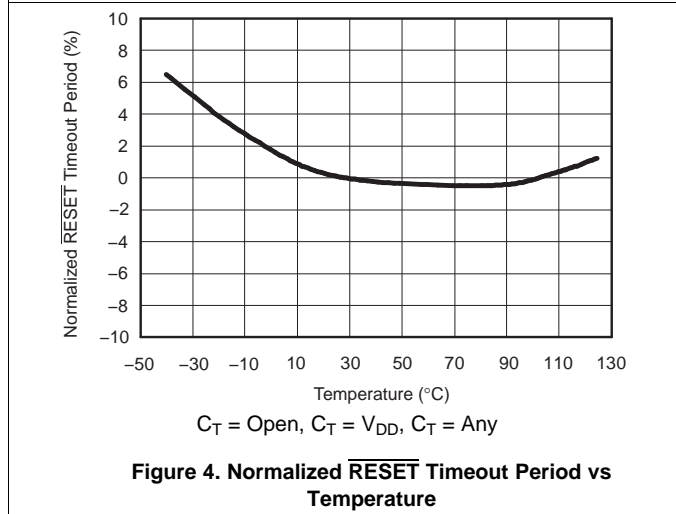
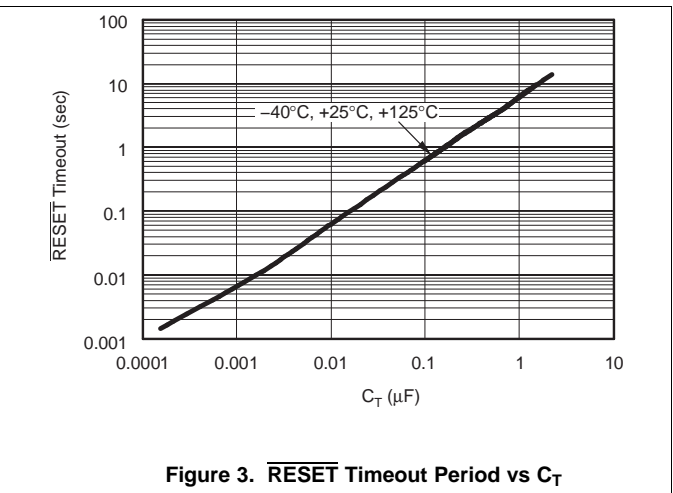
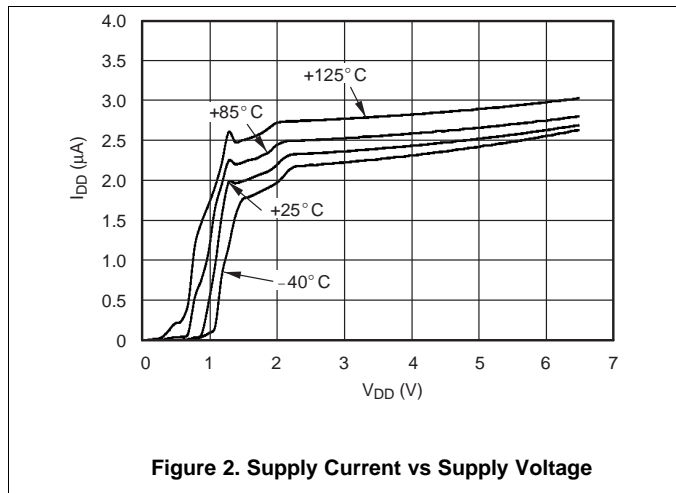

Typical Characteristics (continued)

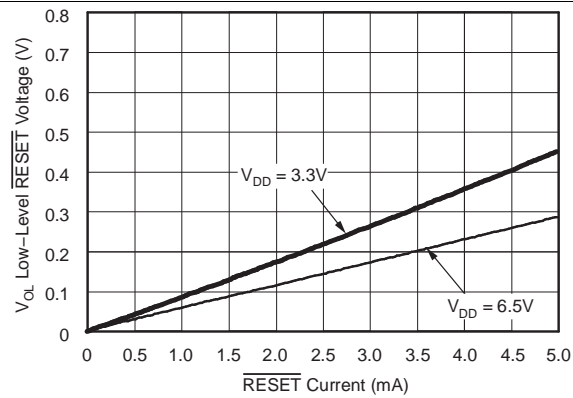
 At $T_J = +25^\circ\text{C}$, $V_{DD} = 3.3\text{ V}$, $R_{L\text{RESET}} = 100\text{k}\Omega$, and $C_{L\text{RESET}} = 50\text{pF}$, unless otherwise noted.

Figure 8. Low-Level $\overline{\text{RESET}}$ Voltage vs $\overline{\text{RESET}}$ Current

7 Detailed Description

7.1 Overview

The TPS3808 microprocessor supervisory product family is designed to assert a $\overline{\text{RESET}}$ signal when either the SENSE pin voltage drops below V_{IT} or the manual reset ($\overline{\text{MR}}$) is driven low. The $\overline{\text{RESET}}$ output remains asserted for a user-adjustable time after both the manual reset ($\overline{\text{MR}}$) and SENSE voltages return above the respective thresholds.

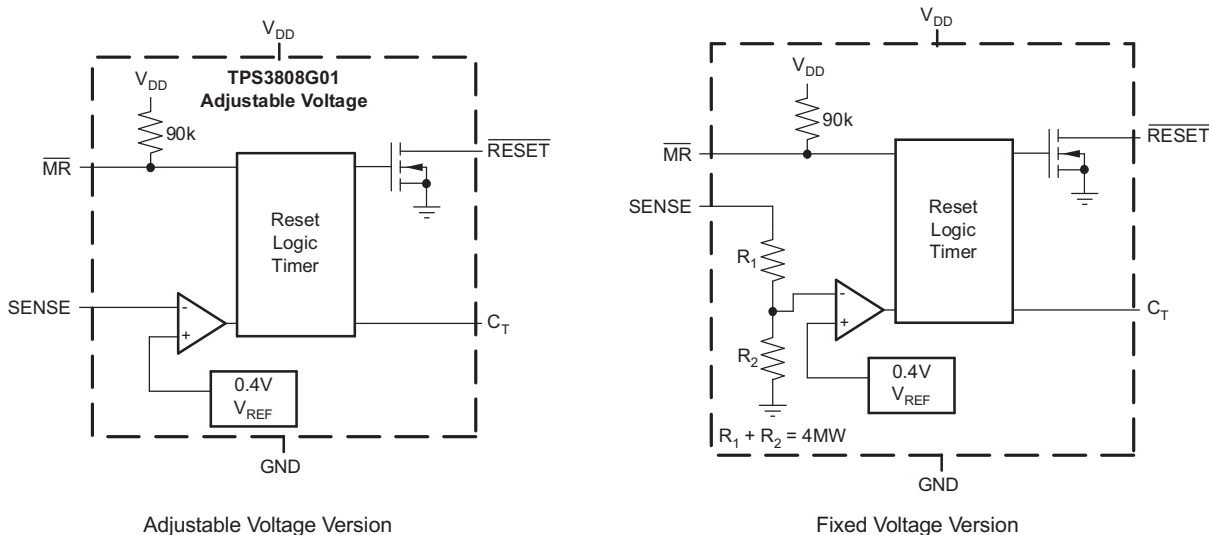
7.2 Functional Block Diagrams



7.3 Feature Description

A broad range of voltage threshold and reset delay time adjustments are available for the TPS3808 device, allowing these devices to be used in a wide array of applications. Reset threshold voltages can be factory-set from 0.82 V to 3.3 V or from 4.4 V to 5.0 V, while the TPS3808G01 can be set to any voltage above 0.405 V using an external resistor divider. Two preset delay times are also user-selectable: connecting the C_T pin to V_{DD} results in a 300 ms reset delay, while leaving the C_T pin open yields a 20-ms reset delay. In addition, connecting a capacitor between C_T and GND allows the designer to select any reset delay period from 1.25 ms to 10 s.

7.4 Device Functional Modes

The TPS3808 has two functional modes:

- $\overline{\text{MR}}$ high: in this mode, $\overline{\text{RESET}}$ is high or low depending on the value of the SENSE pin relative to V_{IT} .
- $\overline{\text{MR}}$ low: in this mode, $\overline{\text{RESET}}$ is held low regardless of the value of the SENSE pin.

8 Application and Implementation

NOTE

Information in the following applications sections is not part of the TI component specification, and TI does not warrant its accuracy or completeness. TI's customers are responsible for determining suitability of components for their purposes. Customers should validate and test their design implementation to confirm system functionality.

8.1 Application Information

The following sections describe in detail how to properly use this device depending on the requirements of the final application.

8.1.1 SENSE Input

The SENSE input provides a terminal at which any system voltage can be monitored. If the voltage on this pin drops below V_{IT} , then $\overline{\text{RESET}}$ is asserted. The comparator has a built-in hysteresis to ensure smooth $\overline{\text{RESET}}$ assertions and de-assertions. It is good analog design practice to put a 1-nF to 10-nF bypass capacitor on the SENSE input to reduce sensitivity to transients and layout parasitics.

The TPS3808 device is relatively immune to short negative transients on the SENSE pin. Sensitivity to transients is dependent on threshold overdrive, as shown in the *Maximum Transient Duration at Sense vs Sense Threshold Overdrive Voltage* graph (Figure 5) in *Typical Characteristics*.

The TPS3808G01 can be used to monitor any voltage rail down to 0.405 V using the circuit shown in Figure 9.

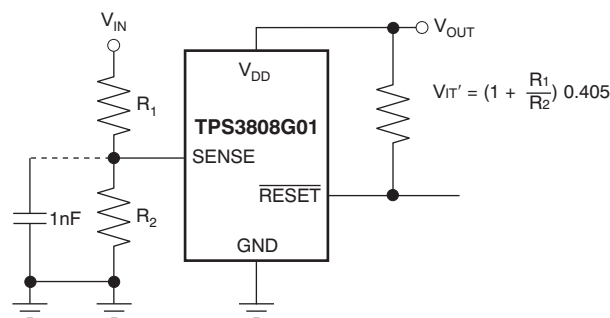

Figure 9. Using the TPS3808G01 to Monitor a User-Defined Threshold Voltage

8.1.2 Selecting the RESET Delay Time

The TPS3808 has three options for setting the $\overline{\text{RESET}}$ delay time as shown in Figure 10. Figure 10a shows the configuration for a fixed 300-ms typical delay time by tying C_T to V_{DD} ; a resistor from 40 k Ω to 200 k Ω must be used. Supply current is not affected by the choice of resistor. Figure 10b shows a fixed 20-ms delay time by leaving the C_T pin open. Figure 10c shows a ground referenced capacitor connected to C_T for a user-defined program time between 1.25 ms and 10 s.

Application Information (continued)

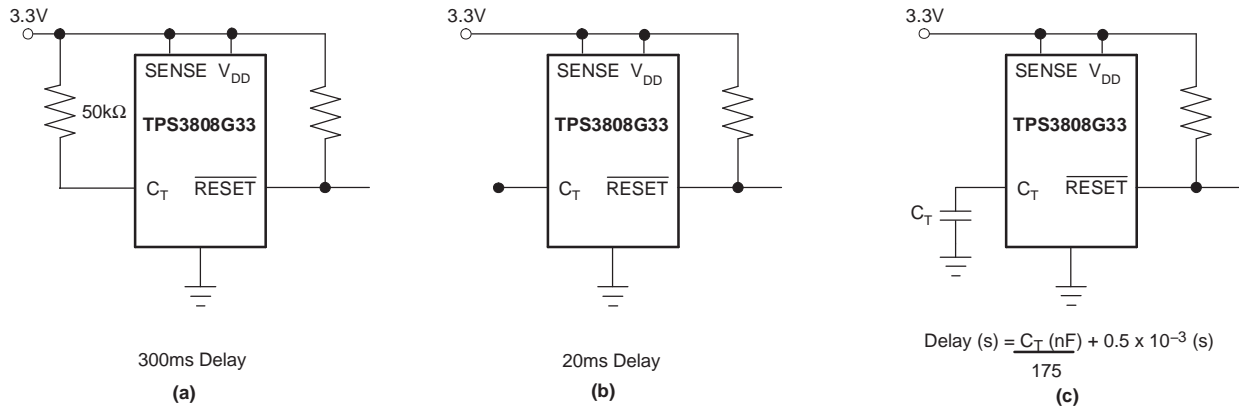

Figure 10. Configuration Used to Set the $\overline{\text{RESET}}$ Delay Time

The capacitor C_T should be ≥ 100 pF nominal value in order for the TPS3808xxx to recognize that the capacitor is present. The capacitor value for a given delay time can be calculated using Equation 1.

$$C_T \text{ (nF)} = [t_D \text{ (s)} - 0.5 \times 10^{-3} \text{ (s)}] \times 175 \tag{1}$$

The reset delay time is determined by the time it takes an on-chip precision 220-nA current source to charge the external capacitor to 1.23 V. When a $\overline{\text{RESET}}$ is asserted the capacitor is discharged. When the $\overline{\text{RESET}}$ conditions are cleared, the internal current source is enabled and begins to charge the external capacitor. When the voltage on this capacitor reaches 1.23 V, $\overline{\text{RESET}}$ is deasserted. Note that a low-leakage type capacitor such as a ceramic should be used, and that stray capacitance around this pin may cause errors in the reset delay time.

8.1.3 Manual $\overline{\text{RESET}}(\overline{\text{MR}})$ Input

The manual reset ($\overline{\text{MR}}$) input allows a processor or other logic circuits to initiate a reset. A logic low ($0.3 V_{DD}$) on MR causes $\overline{\text{RESET}}$ to assert. After MR returns to a logic high and SENSE is above its reset threshold, $\overline{\text{RESET}}$ is de-asserted after the user defined reset delay expires. Note that $\overline{\text{MR}}$ is internally tied to V_{DD} using a 90-kΩ resistor so this pin can be left unconnected if MR will not be used.

See Figure 11 for how $\overline{\text{MR}}$ can be used to monitor multiple system voltages. Note that if the logic signal driving MR does not go fully to V_{DD} , there will be some additional current draw into V_{DD} as a result of the internal pullup resistor on MR. To minimize current draw, a logic-level FET can be used as illustrated in Figure 12.

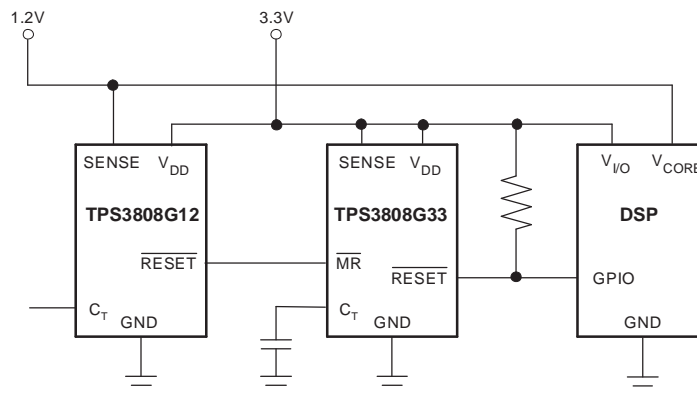

Figure 11. Using $\overline{\text{MR}}$ to Monitor Multiple System Voltages

Application Information (continued)

Figure 12. Using an External MOSFET to Minimize I_{DD} When \overline{MR} Signal Does Not Go to V_{DD}

8.1.4 RESET Output

\overline{RESET} remains high (unasserted) as long as \overline{SENSE} is above its threshold (V_{IT}) and the manual reset (\overline{MR}) is logic high. If either \overline{SENSE} falls below V_{IT} or \overline{MR} is driven low, \overline{RESET} is asserted, driving the \overline{RESET} pin to a low impedance.

Once \overline{MR} is again logic high and \overline{SENSE} is above $V_{IT} + V_{HYS}$ (the threshold hysteresis), a delay circuit is enabled which holds \overline{RESET} low for a specified reset delay period. Once the reset delay has expired, the \overline{RESET} pin goes to a high impedance state. The pullup resistor from the open-drain \overline{RESET} to the supply line can be used to allow the reset signal for the microprocessor to have a voltage higher than V_{DD} (up to 6.5 V). The pullup resistor should be no smaller than 10 k Ω as a result of the finite impedance of the \overline{RESET} line.

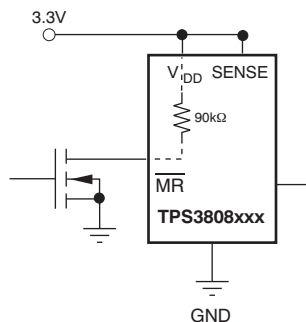
8.2 Typical Application

A typical application of the TPS3808G33 used with a 3.3 V processor is shown in Figure 13. The open-drain RESET output is typically connected to the RESET input of a microprocessor. A pullup resistor must be used to hold this line high when RESET is not asserted. The RESET output is undefined for voltage below 0.8 V, but this is normally not a problem since most microprocessors do not function below this voltage.

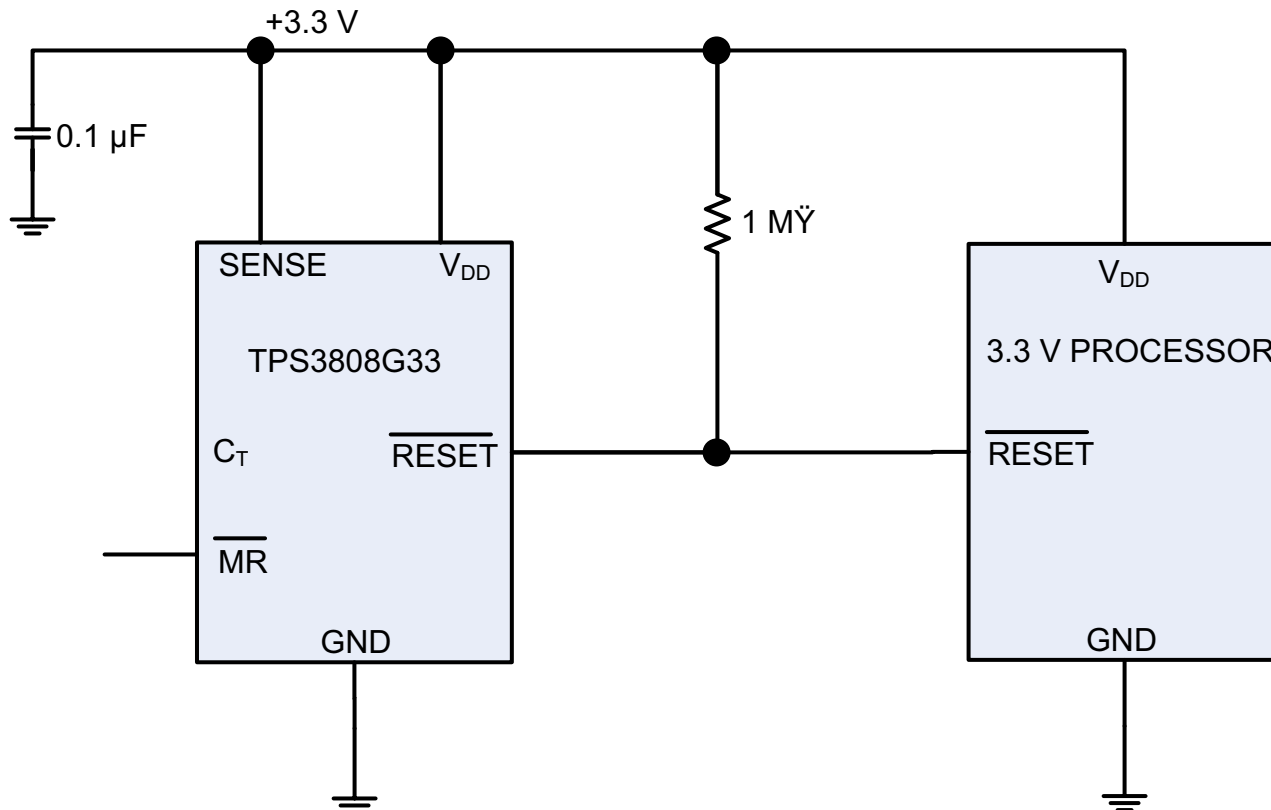

Figure 13. Typical Application of the TPS3808 with a 3.3 V Processor

8.2.1 Design Requirements

The TPS3808 is intended to drive the RESET input of a microprocessor. The RESET pin is pulled high with a 1 MΩ resistor and the reset delay time is controlled by C_T depending on the reset requirement times of the microprocessor. In this case, C_T is left open for a typical reset delay time of 20 ms.

8.2.2 Detailed Design Procedure

The main constraint for this application is the reset delay time. In this case, since C_T is open, it is set to 20 ms. A 0.1 µF decoupling capacitor is connected to the V_{DD} pin and a 1 MΩ resistor is used to pull-up the RESET pin high. The MR pin can be connected to an external signal if desired.

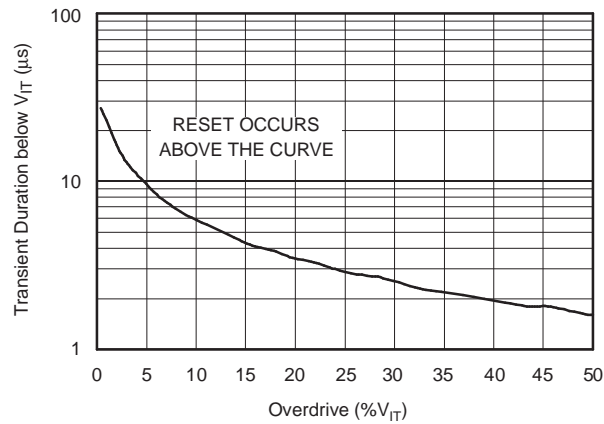
Typical Application (continued)
8.2.3 Application Curve

Figure 14. Maximum Transient Duration at Sense vs Sense Threshold Overdrive Voltage

9 Power Supply Recommendations

These devices are designed to operate from an input supply with a voltage range between 1.7 and 6.5 V. Use a low-impedance power supply to eliminate inaccuracies caused by the current during the voltage reference refresh.

10 Layout

10.1 Layout Guidelines

Make sure the connection to the V_{DD} pin is low impedance. Place a 0.1- μF ceramic capacitor near the V_{DD} pin.

10.2 Layout Example

The layout example in [Figure 15](#) shows how the TPS3808 is laid out on a PCB for a 20 ms delay.

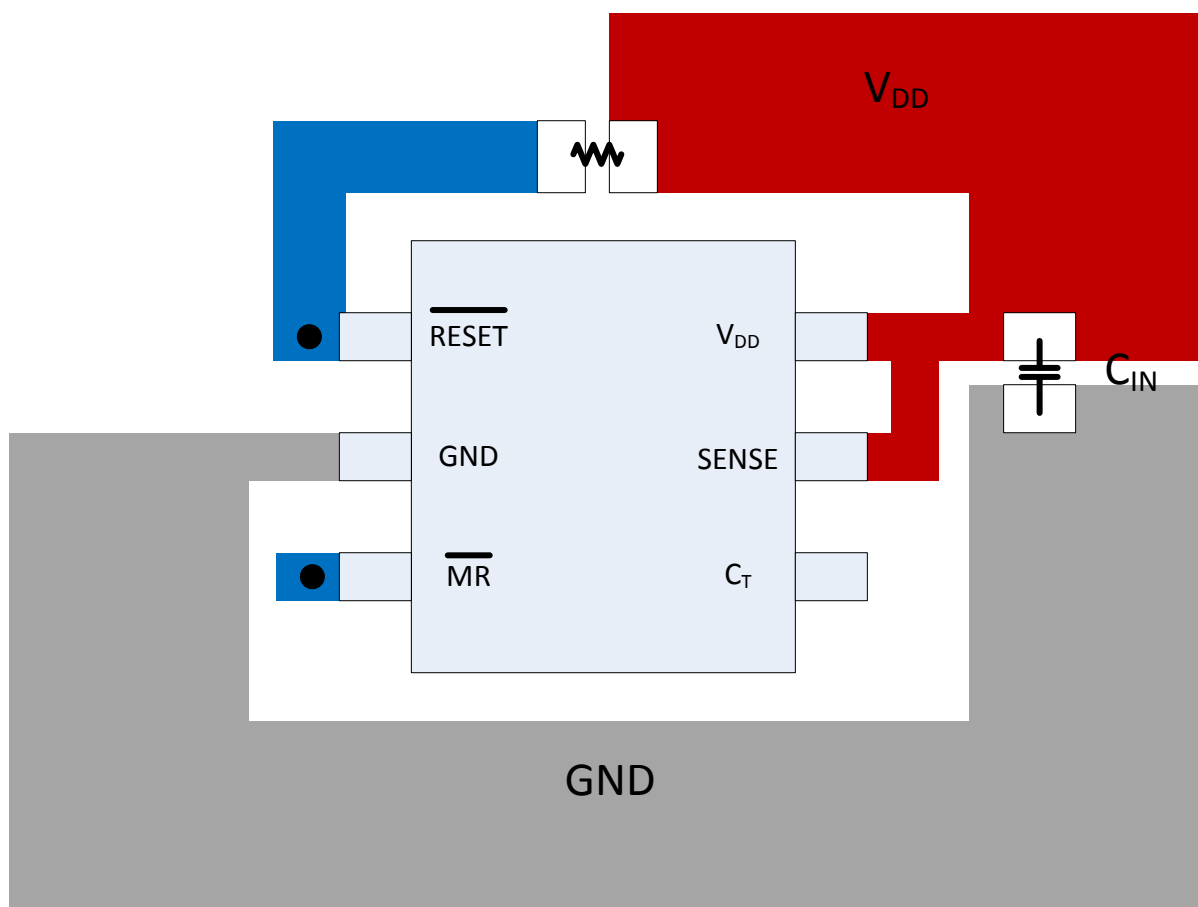

- VIAS USED TO CONNECT PINS FOR APPLICATION SPECIFIC CONNECTIONS

Figure 15. Layout Example for a 20 ms Delay

11 Device and Documentation Support

11.1 Trademarks

All trademarks are the property of their respective owners.

11.2 Electrostatic Discharge Caution



These devices have limited built-in ESD protection. The leads should be shorted together or the device placed in conductive foam during storage or handling to prevent electrostatic damage to the MOS gates.

11.3 Glossary

[SLYZ022](#) — *TI Glossary*.

This glossary lists and explains terms, acronyms, and definitions.

12 Mechanical, Packaging, and Orderable Information

The following pages include mechanical, packaging, and orderable information. This information is the most current data available for the designated devices. This data is subject to change without notice and revision of this document. For browser-based versions of this data sheet, refer to the left-hand navigation.

PACKAGING INFORMATION

Orderable Device	Status (1)	Package Type	Package Drawing	Pins	Package Qty	Eco Plan (2)	Lead/Ball Finish (6)	MSL Peak Temp (3)	Op Temp (°C)	Device Marking (4/5)	Samples
TPS3808G01MDBVTEP	ACTIVE	SOT-23	DBV	6	250	Green (RoHS & no Sb/Br)	CU NIPDAU	Level-1-260C-UNLIM	-55 to 125	NXS	Samples
TPS3808G33MDBVREP	ACTIVE	SOT-23	DBV	6	3000	Green (RoHS & no Sb/Br)	CU NIPDAU	Level-1-260C-UNLIM	-55 to 125	CHK	Samples
V62/08607-01XE	ACTIVE	SOT-23	DBV	6	250	Green (RoHS & no Sb/Br)	CU NIPDAU	Level-1-260C-UNLIM	-55 to 125	NXS	Samples
V62/08607-09XE	ACTIVE	SOT-23	DBV	6	3000	Green (RoHS & no Sb/Br)	CU NIPDAU	Level-1-260C-UNLIM	-55 to 125	CHK	Samples

(1) The marketing status values are defined as follows:

ACTIVE: Product device recommended for new designs.

LIFEBUY: TI has announced that the device will be discontinued, and a lifetime-buy period is in effect.

NRND: Not recommended for new designs. Device is in production to support existing customers, but TI does not recommend using this part in a new design.

PREVIEW: Device has been announced but is not in production. Samples may or may not be available.

OBSOLETE: TI has discontinued the production of the device.

(2) Eco Plan - The planned eco-friendly classification: Pb-Free (RoHS), Pb-Free (RoHS Exempt), or Green (RoHS & no Sb/Br) - please check <http://www.ti.com/productcontent> for the latest availability information and additional product content details.

TBD: The Pb-Free/Green conversion plan has not been defined.

Pb-Free (RoHS): TI's terms "Lead-Free" or "Pb-Free" mean semiconductor products that are compatible with the current RoHS requirements for all 6 substances, including the requirement that lead not exceed 0.1% by weight in homogeneous materials. Where designed to be soldered at high temperatures, TI Pb-Free products are suitable for use in specified lead-free processes.

Pb-Free (RoHS Exempt): This component has a RoHS exemption for either 1) lead-based flip-chip solder bumps used between the die and package, or 2) lead-based die adhesive used between the die and leadframe. The component is otherwise considered Pb-Free (RoHS compatible) as defined above.

Green (RoHS & no Sb/Br): TI defines "Green" to mean Pb-Free (RoHS compatible), and free of Bromine (Br) and Antimony (Sb) based flame retardants (Br or Sb do not exceed 0.1% by weight in homogeneous material)

(3) MSL, Peak Temp. - The Moisture Sensitivity Level rating according to the JEDEC industry standard classifications, and peak solder temperature.

(4) There may be additional marking, which relates to the logo, the lot trace code information, or the environmental category on the device.

(5) Multiple Device Markings will be inside parentheses. Only one Device Marking contained in parentheses and separated by a "~" will appear on a device. If a line is indented then it is a continuation of the previous line and the two combined represent the entire Device Marking for that device.

(6) Lead/Ball Finish - Orderable Devices may have multiple material finish options. Finish options are separated by a vertical ruled line. Lead/Ball Finish values may wrap to two lines if the finish value exceeds the maximum column width.

Important Information and Disclaimer: The information provided on this page represents TI's knowledge and belief as of the date that it is provided. TI bases its knowledge and belief on information provided by third parties, and makes no representation or warranty as to the accuracy of such information. Efforts are underway to better integrate information from third parties. TI has taken and continues to take reasonable steps to provide representative and accurate information but may not have conducted destructive testing or chemical analysis on incoming materials and chemicals. TI and TI suppliers consider certain information to be proprietary, and thus CAS numbers and other limited information may not be available for release.

In no event shall TI's liability arising out of such information exceed the total purchase price of the TI part(s) at issue in this document sold by TI to Customer on an annual basis.

TAPE AND REEL INFORMATION



QUADRANT ASSIGNMENTS FOR PIN 1 ORIENTATION IN TAPE



*All dimensions are nominal

Device	Package Type	Package Drawing	Pins	SPQ	Reel Diameter (mm)	Reel Width W1 (mm)	A0 (mm)	B0 (mm)	K0 (mm)	P1 (mm)	W (mm)	Pin1 Quadrant
TPS3808G01MDBVTEP	SOT-23	DBV	6	250	179.0	8.4	3.2	3.2	1.4	4.0	8.0	Q3
TPS3808G33MDBVREP	SOT-23	DBV	6	3000	179.0	8.4	3.2	3.2	1.4	4.0	8.0	Q3

TAPE AND REEL BOX DIMENSIONS



*All dimensions are nominal

Device	Package Type	Package Drawing	Pins	SPQ	Length (mm)	Width (mm)	Height (mm)
TPS3808G01MDBVTEP	SOT-23	DBV	6	250	203.0	203.0	35.0
TPS3808G33MDBVREP	SOT-23	DBV	6	3000	203.0	203.0	35.0

EXAMPLE BOARD LAYOUT

DBV0006A

SOT-23 - 1.45 mm max height

SMALL OUTLINE TRANSISTOR



LAND PATTERN EXAMPLE
EXPOSED METAL SHOWN
SCALE:15X



SOLDER MASK DETAILS

4214840/B 03/2018

NOTES: (continued)

- 6. Publication IPC-7351 may have alternate designs.
- 7. Solder mask tolerances between and around signal pads can vary based on board fabrication site.

EXAMPLE STENCIL DESIGN

DBV0006A

SOT-23 - 1.45 mm max height

SMALL OUTLINE TRANSISTOR



SOLDER PASTE EXAMPLE
BASED ON 0.125 mm THICK STENCIL
SCALE:15X

4214840/B 03/2018

NOTES: (continued)

8. Laser cutting apertures with trapezoidal walls and rounded corners may offer better paste release. IPC-7525 may have alternate design recommendations.
9. Board assembly site may have different recommendations for stencil design.

IMPORTANT NOTICE AND DISCLAIMER

TI PROVIDES TECHNICAL AND RELIABILITY DATA (INCLUDING DATASHEETS), DESIGN RESOURCES (INCLUDING REFERENCE DESIGNS), APPLICATION OR OTHER DESIGN ADVICE, WEB TOOLS, SAFETY INFORMATION, AND OTHER RESOURCES "AS IS" AND WITH ALL FAULTS, AND DISCLAIMS ALL WARRANTIES, EXPRESS AND IMPLIED, INCLUDING WITHOUT LIMITATION ANY IMPLIED WARRANTIES OF MERCHANTABILITY, FITNESS FOR A PARTICULAR PURPOSE OR NON-INFRINGEMENT OF THIRD PARTY INTELLECTUAL PROPERTY RIGHTS.

These resources are intended for skilled developers designing with TI products. You are solely responsible for (1) selecting the appropriate TI products for your application, (2) designing, validating and testing your application, and (3) ensuring your application meets applicable standards, and any other safety, security, or other requirements. These resources are subject to change without notice. TI grants you permission to use these resources only for development of an application that uses the TI products described in the resource. Other reproduction and display of these resources is prohibited. No license is granted to any other TI intellectual property right or to any third party intellectual property right. TI disclaims responsibility for, and you will fully indemnify TI and its representatives against, any claims, damages, costs, losses, and liabilities arising out of your use of these resources.

TI's products are provided subject to TI's Terms of Sale (www.ti.com/legal/termsofsale.html) or other applicable terms available either on ti.com or provided in conjunction with such TI products. TI's provision of these resources does not expand or otherwise alter TI's applicable warranties or warranty disclaimers for TI products.

Mailing Address: Texas Instruments, Post Office Box 655303, Dallas, Texas 75265
Copyright © 2019, Texas Instruments Incorporated

Looking for pricing, stock, or lifecycle information?

Click below to explore more details on WIN SOURCE:

- ⊖ [View TPS3808G01MDBVTEP](#) on WIN SOURCE
- ⊖ [Texas Instruments](#) Information

Optimize Your Supply Chain with WIN SOURCE Solutions

- ✓ Global Sourcing Solution
- ✓ Obsolete Management
- ✓ Cost Control Management
- ✓ Shortage Management
- ✓ Alternative Solution
- ✓ Excess Inventory Management