



THE DATASHEET OF TPS3808G18DBVR



TPS3808 Low-Quiescent-Current, Programmable-Delay Supervisory Circuit

1 Features

- Power-on reset generator with adjustable delay time: 1.25 ms to 10 s
- Very low quiescent current: 2.4 μA typical
- High threshold accuracy: 0.5% typical
- Fixed threshold voltages for standard voltage rails from 0.9 V to 5 V and adjustable voltage down to 0.4 V are available
- Manual reset ($\overline{\text{MR}}$) input
- Open-drain $\overline{\text{RESET}}$ output
- Temperature range: -40°C to 125°C
- Small SOT-23 and 2-mm \times 2-mm WSON packages

2 Applications

- DSP or microcontroller applications
- Notebook and desktop computers
- PDAs and hand-held products
- Portable and battery-powered products
- FPGA and ASIC applications

3 Description

The TPS3808 family of microprocessor supervisory circuits monitors system voltages from 0.4 V to 5 V, asserting an open-drain $\overline{\text{RESET}}$ signal when the SENSE voltage drops below a preset threshold or when the manual reset ($\overline{\text{MR}}$) pin drops to a logic low. The $\overline{\text{RESET}}$ output remains low for the user-adjustable delay time after the SENSE voltage and manual reset ($\overline{\text{MR}}$) return above the respective thresholds.

The TPS3808 device uses a precision reference to achieve 0.5% threshold accuracy for $V_{\text{IT}} \leq 3.3$ V. The reset delay time can be set to 20 ms by disconnecting the C_{T} pin, 300 ms by connecting the C_{T} pin to V_{DD} using a resistor, or can be user-adjusted between 1.25 ms and 10 s by connecting the C_{T} pin to an external capacitor. The TPS3808 device has a very low typical quiescent current of 2.4 μA , so it is well-suited to battery-powered applications. It is available in the SOT-23 and 2-mm \times 2-mm WSON packages, and is fully specified over a temperature range of -40°C to 125°C (T_{J}).

Device Information

PART NUMBER	PACKAGE ⁽¹⁾	BODY SIZE (NOM)
TPS3808	SOT-23 (6)	2.90 mm x 1.60 mm
	WSON (6)	2.00 mm x 2.00 mm

- (1) For all available packages, see the orderable addendum at the end of the data sheet.

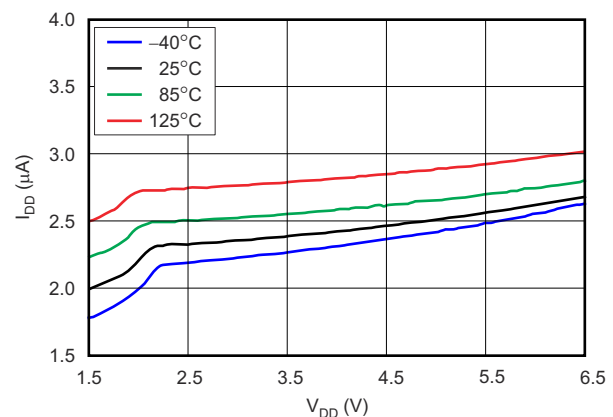
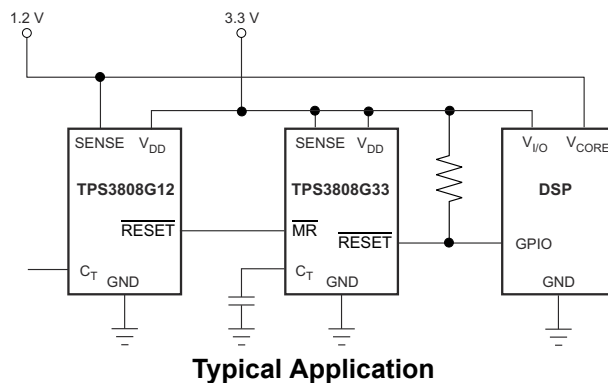

Supply Current vs Supply Voltage



Table of Contents

1 Features	1	8.4 Device Functional Modes.....	13
2 Applications	1	9 Application and Implementation	14
3 Description	1	9.1 Application Information.....	14
4 Revision History	2	9.2 Typical Application.....	14
5 Device Voltage Thresholds	3	10 Power Supply Recommendations	15
6 Pin Configuration and Functions	4	11 Layout	15
7 Specifications	5	11.1 Layout Guidelines.....	15
7.1 Absolute Maximum Ratings.....	5	11.2 Layout Example.....	15
7.2 ESD Ratings.....	5	12 Device and Documentation Support	17
7.3 Recommended Operating Conditions.....	5	12.1 Device Support.....	17
7.4 Thermal Information.....	5	12.2 Documentation Support.....	17
7.5 Electrical Characteristics.....	6	12.3 Support Resources.....	17
7.6 Switching Characteristics.....	7	12.4 Trademarks.....	17
7.7 Typical Characteristics.....	8	12.5 Electrostatic Discharge Caution.....	17
8 Detailed Description	10	12.6 Glossary.....	17
8.1 Overview.....	10	13 Mechanical, Packaging, and Orderable Information	17
8.2 Functional Block Diagram.....	10		
8.3 Feature Description.....	10		

4 Revision History

NOTE: Page numbers for previous revisions may differ from page numbers in the current version.

Changes from Revision L (September 2020) to Revision M (March 2023)	Page
• Updated <i>Device Voltage Thresholds</i> footnote.....	3
• Updated <i>Thermal Information</i>	5

Changes from Revision K (October 2015) to Revision L (September 2020)	Page
• Updated the numbering format for tables, figures and cross-references throughout the document.....	1

Changes from Revision J (August 2008) to Revision K (October 2015)	Page
• Added <i>ESD Ratings</i> table, <i>Feature Description</i> section, <i>Device Functional Modes</i> , <i>Application and Implementation</i> section, <i>Power Supply Recommendations</i> section, <i>Layout</i> section, <i>Device and Documentation Support</i> section, and <i>Mechanical, Packaging, and Orderable Information</i> section. Moved <i>Switching Characteristics</i> table, timing diagram, and related truth table.....	1
• Changed Figure 9-1 ; removed capacitor shown on C _T	14

5 Device Voltage Thresholds

The following table shows the nominal rail to be monitored and the corresponding threshold voltage of the device.

PART NUMBER	NOMINAL SUPPLY VOLTAGE ⁽¹⁾	THRESHOLD VOLTAGE (V _{IT})
TPS3808G01	Adjustable	0.405 V
TPS3808G09	0.9 V	0.84 V
TPS3808G12	1.2 V	1.12 V
TPS3808G125	1.25 V	1.16 V
TPS3808G15	1.5 V	1.40 V
TPS3808G18	1.8 V	1.67 V
TPS3808G19	1.9 V	1.77 V
TPS3808G25	2.5 V	2.33 V
TPS3808G30	3 V	2.79 V
TPS3808G33	3.3 V	3.07 V
TPS3808G50	5 V	4.65 V

(1) Please contact TI for availability of other threshold options.

6 Pin Configuration and Functions

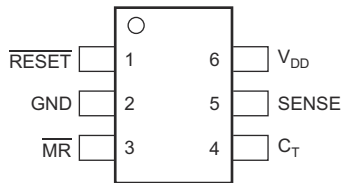

Figure 6-1. DBV Package 6-Pin SOT-23 Top View

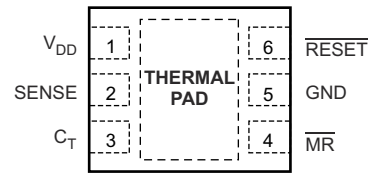

Figure 6-2. DRV Package 6-Pin (2.00 mm × 2.00 mm) WSON With Thermal Pad Top View

Table 6-1. Pin Functions

NAME	PIN		I/O	DESCRIPTION
	SOT-23	WSON		
C_T	4	3	I	Reset period programming pin. Connecting this pin to V_{DD} through a 40-k Ω to 200-k Ω resistor or leaving it open results in fixed delay times (see Section 7.5). Connecting this pin to a ground referenced capacitor ≥ 100 pF gives a user-programmable delay time. See Section 8.3.2 for more information.
GND	2	5	—	Ground
\overline{MR}	3	4	I	Driving the manual reset pin (\overline{MR}) low asserts \overline{RESET} . \overline{MR} is internally tied to V_{DD} by a 90-k Ω pull-up resistor.
\overline{RESET}	1	6	O	\overline{RESET} is an open-drain output that is driven to a low-impedance state when \overline{RESET} is asserted (either the SENSE input is lower than the threshold voltage (V_{IT}) or the \overline{MR} pin is set to a logic low). \overline{RESET} remains low (asserted) for the reset period after both SENSE is above V_{IT} and \overline{MR} is set to a logic high. A pull-up resistor from 10 k Ω to 1 M Ω should be used on this pin, and allows the reset pin to attain voltages higher than V_{DD} .
SENSE	5	2	I	This pin is connected to the voltage to be monitored. If the voltage at this terminal drops below the threshold voltage V_{IT} , then \overline{RESET} is asserted.
V_{DD}	6	1	I	Supply voltage. It is good analog design practice to place a 0.1- μ F ceramic capacitor close to this pin.
Thermal Pad	—	Pad	—	Thermal Pad. Connect to ground plane to enhance thermal performance of package.

7 Specifications

7.1 Absolute Maximum Ratings

over operating junction temperature range (unless otherwise noted) ⁽¹⁾

		MIN	MAX	UNIT
Voltage	V _{DD}	-0.3	7	V
	V _{CT}	-0.3	V _{DD} + 0.3	V
	V _{RESET} , V _{MR} , V _{SENSE}	-0.3	7	V
Current	RESET pin	-5	5	mA
Temperature	Operating junction, T _J ⁽²⁾	-40	150	°C
	Storage, T _{stg}	-65	150	°C

- (1) Stresses beyond those listed under *Absolute Maximum Ratings* may cause permanent damage to the device. These are stress ratings only, which do not imply functional operation of the device at these or any other conditions beyond those indicated under *Recommended Operating Conditions*. Exposure to absolute-maximum-rated conditions for extended periods may affect device reliability.
- (2) As a result of the low dissipated power in this device, it is assumed that T_J = T_A.

7.2 ESD Ratings

		VALUE	UNIT
V _(ESD)	Electrostatic discharge	Human body model (HBM), per ANSI/ESDA/JEDEC JS-001, all pins ⁽¹⁾	±2000
		Charged device model (CDM), per JEDEC specification JESD22-C101, all pins ⁽²⁾	±500

- (1) JEDEC document JEP155 states that 500-V HBM allows safe manufacturing with a standard ESD control process.
- (2) JEDEC document JEP157 states that 250-V CDM allows safe manufacturing with a standard ESD control process.

7.3 Recommended Operating Conditions

over operating free-air temperature range (unless otherwise noted)

		MIN	NOM	MAX	UNIT
V _{DD}	Input supply range	1.7		6.5	V
V _{SENSE}	SENSE pin voltage	0		6.5	V
V _(CT)	C _T pin voltage			V _{DD}	V
V _{MR}	MR pin voltage	0		6.5	V
V _{RESET}	RESET pin voltage	0		6.5	V
I _{RESET}	RESET pin current	0.0003		5	mA

7.4 Thermal Information

THERMAL METRIC ⁽¹⁾		TPS3808		UNIT
		DBV (SOT-23)	DRV (WSON)	
		6 PINS	6 PINS	
R _{θJA}	Junction-to-ambient thermal resistance	180.9	178.1	°C/W
R _{θJC(top)}	Junction-to-case (top) thermal resistance	117.8	95.6	°C/W
R _{θJB}	Junction-to-board thermal resistance	27.8	135	°C/W
ψ _{JT}	Junction-to-top characterization parameter	18.9	6.3	°C/W
ψ _{JB}	Junction-to-board characterization parameter	27.3	136.6	°C/W
R _{θJC(bot)}	Junction-to-case (bottom) thermal resistance	N/A	7.3	°C/W

- (1) For more information about traditional and new thermal metrics, see the *Semiconductor and IC Package Thermal Metrics* application report, [SPRA953](#).

7.5 Electrical Characteristics

$1.7\text{ V} \leq V_{DD} \leq 6.5\text{ V}$, $R_{LRESET} = 100\text{ k}\Omega$, $C_{LRESET} = 50\text{ pF}$, over operating temperature range ($T_J = -40^\circ\text{C}$ to 125°C), unless otherwise noted. Typical values are at $T_J = 25^\circ\text{C}$ ⁽¹⁾.

PARAMETER		TEST CONDITIONS	MIN	TYP	MAX	UNIT
V_{DD}	Input supply range	$-40^\circ\text{C} < T_J < 125^\circ\text{C}$	1.7		6.5	V
		$0^\circ\text{C} < T_J < 85^\circ\text{C}$	1.65		6.5	V
I_{DD}	Supply current (current into V_{DD} pin)	$V_{DD} = 3.3\text{ V}$, $\overline{\text{RESET}}$ not asserted $\overline{\text{MR}}$, $\overline{\text{RESET}}$, C_T open		2.4	5	μA
		$V_{DD} = 6.5\text{ V}$, $\overline{\text{RESET}}$ not asserted $\overline{\text{MR}}$, $\overline{\text{RESET}}$, C_T open		2.7	6	
V_{OL}	Low-level output voltage	$1.3\text{ V} \leq V_{DD} < 1.8\text{ V}$, $I_{OL} = 0.4\text{ mA}$			0.3	V
		$1.8\text{ V} \leq V_{DD} \leq 6.5\text{ V}$, $I_{OL} = 1\text{ mA}$			0.4	
V_{POR}	Power-up reset voltage ⁽²⁾	$V_{OL}(\text{max}) = 0.2\text{ V}$, $I_{\overline{\text{RESET}}} = 15\text{ }\mu\text{A}$			0.8	
V_{IT}	Negative-going input threshold accuracy	TPS3808G01		-2%	$\pm 1\%$	2%
		$V_{IT} \leq 3.3\text{ V}$		-1.5%	$\pm 0.5\%$	1.5%
		$3.3\text{ V} < V_{IT} \leq 5.0\text{ V}$		-2%	$\pm 1\%$	2%
		$V_{IT} \leq 3.3\text{ V}$	$-40^\circ\text{C} < T_J < 85^\circ\text{C}$	-1.25%	$\pm 0.5\%$	1.25%
		$3.3\text{ V} < V_{IT} \leq 5.0\text{ V}$	$-40^\circ\text{C} < T_J < 85^\circ\text{C}$	-1.5%	$\pm 0.5\%$	1.5%
V_{HYS}	Hysteresis on V_{IT} pin	TPS3808G01		1.5%	3%	V_{IT}
		Fixed versions		1%	2.5%	
$R_{\overline{\text{MR}}}$	$\overline{\text{MR}}$ Internal pullup resistance		70	90		$\text{k}\Omega$
I_{SENSE}	Input current at SENSE pin	TPS3808G01	$V_{\text{SENSE}} = V_{IT}$	-25	25	nA
		Fixed versions	$V_{\text{SENSE}} = 6.5\text{ V}$		1.7	μA
I_{OH}	$\overline{\text{RESET}}$ leakage current	$V_{\overline{\text{RESET}}} = 6.5\text{ V}$, $\overline{\text{RESET}}$ not asserted			300	nA
C_{IN}	Input capacitance, any pin	C_T pin	$V_{IN} = 0\text{ V}$ to V_{DD}		5	pF
		Other pins	$V_{IN} = 0\text{ V}$ to 6.5 V		5	
V_{IL}	$\overline{\text{MR}}$ logic low input		0		$0.3 V_{DD}$	V
V_{IH}	$\overline{\text{MR}}$ logic high input		$0.7 V_{DD}$		V_{DD}	

(1) The lowest supply voltage (V_{DD}) at which $\overline{\text{RESET}}$ becomes active. $T_{\text{rise}(V_{DD})} \geq 15\text{ }\mu\text{s/V}$.

(2) R_{LRESET} and C_{LRESET} are the resistor and capacitor connected to the $\overline{\text{RESET}}$ pin.

7.6 Switching Characteristics

1.7 V ≤ V_{DD} ≤ 6.5 V, R_{LRESET} = 100 kΩ, C_{LRESET} = 50 pF, over operating temperature range (T_J = –40°C to 125°C), unless otherwise noted. Typical values are at T_J = 25°C.⁽¹⁾

PARAMETER		TEST CONDITIONS	MIN	TYP	MAX	UNIT
t _w	Input pulse width to RESET	SENSE	V _{IH} = 1.05 V _{IT} , V _{IL} = 0.95 V _{IT}			μs
		MR	V _{IH} = 0.7 V _{DD} , V _{IL} = 0.3 V _{DD}			
t _d	RESET delay time	C _T = Open	12	20	28	ms
		C _T = V _{DD}	180	300	420	
		C _T = 100 pF	0.75	1.25	1.75	
		C _T = 180 nF	0.7	1.2	1.7	s
Propagation delay		MR to RESET	V _{IH} = 0.7 V _{DD} , V _{IL} = 0.3 V _{DD}			ns
High-to-low level RESET delay		SENSE to RESET	V _{IH} = 1.05 V _{IT} , V _{IL} = 0.95 V _{IT}			μs

(1) R_{LRESET} and C_{LRESET} are the resistor and capacitor connected to the RESET pin.

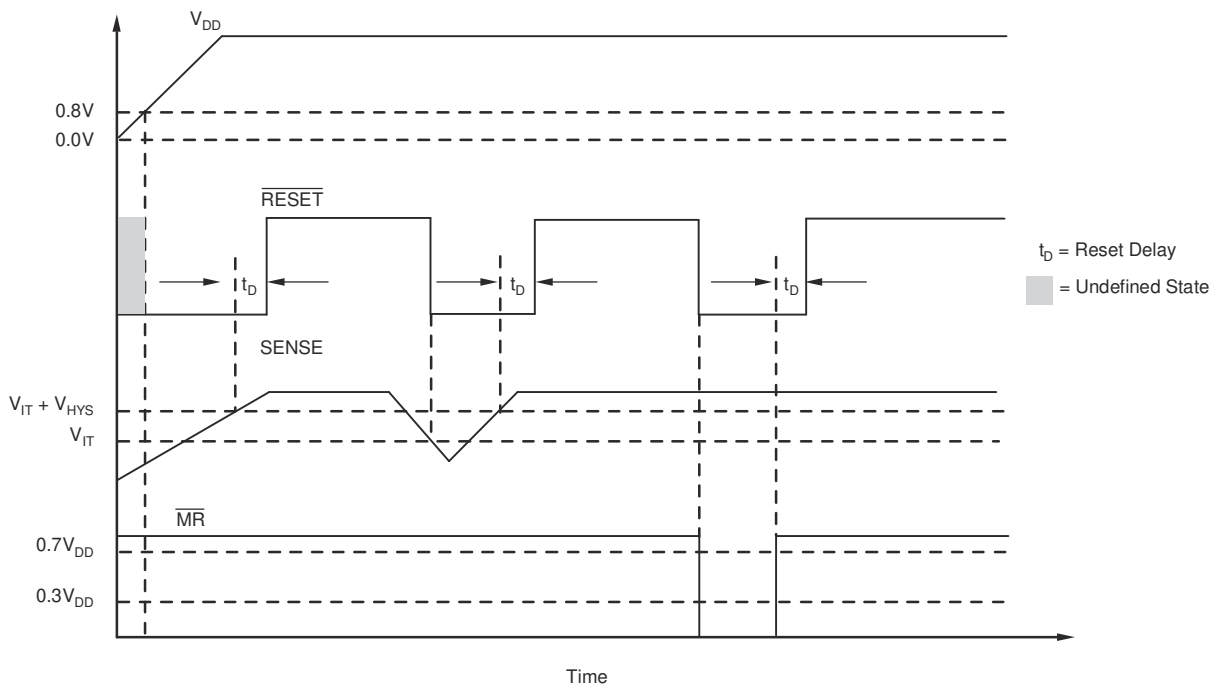

Figure 7-1. TPS3808 Timing Diagram Showing MR and SENSE Reset Timing

7.7 Typical Characteristics

At $T_J = 25^\circ\text{C}$, $V_{DD} = 3.3\text{ V}$, $R_{L\text{RESET}} = 100\text{ k}\Omega$, and $C_{L\text{RESET}} = 50\text{ pF}$, unless otherwise noted.

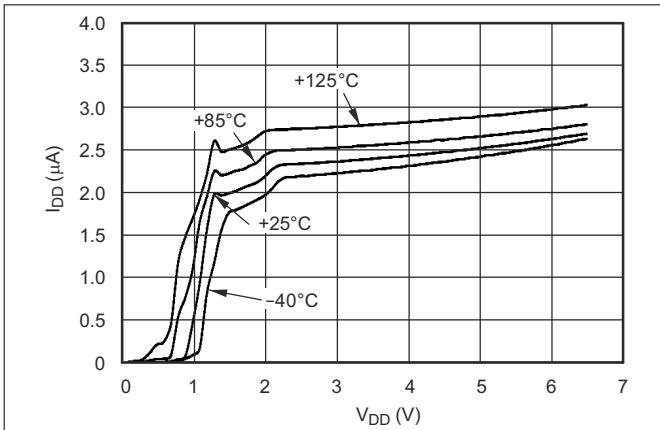

Figure 7-2. Supply Current vs Supply Voltage

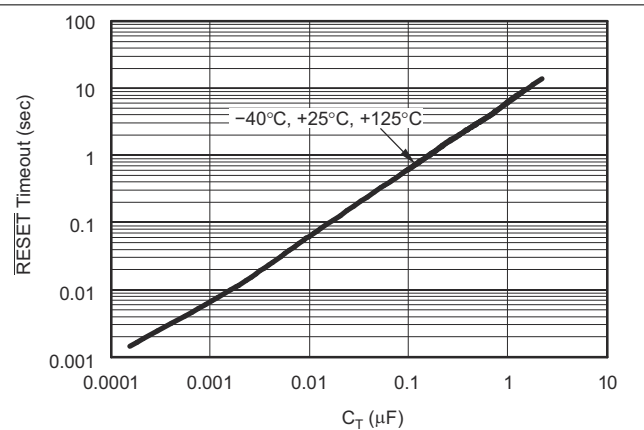

Figure 7-3. RESET Time-Out Period vs C_T

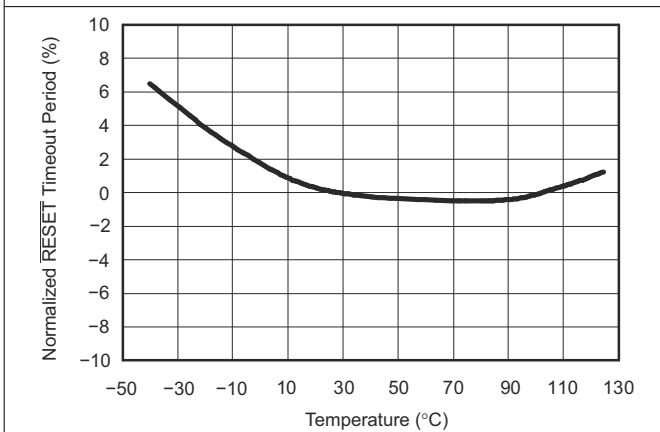

Figure 7-4. Normalized RESET Time-Out Period vs Temperature ($C_T = \text{Open}$, $C_T = V_{DD}$, $C_T = \text{Any}$)

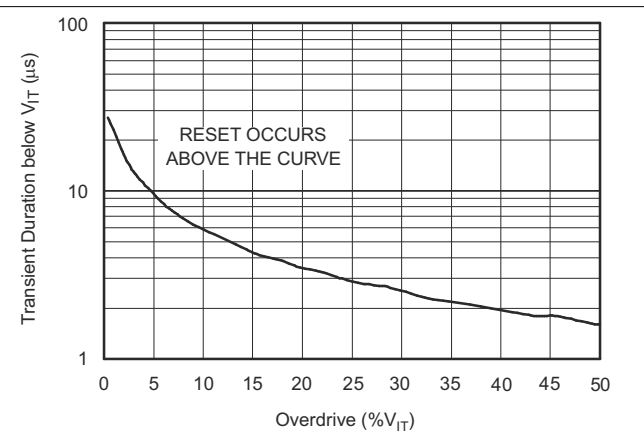

Figure 7-5. Maximum Transient Duration at Sense vs Sense Threshold Overdrive Voltage

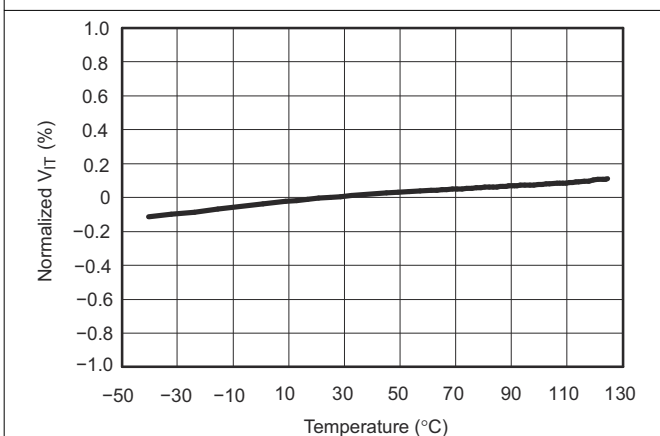

Figure 7-6. Normalized Sense Threshold Voltage (V_{IT}) vs Temperature

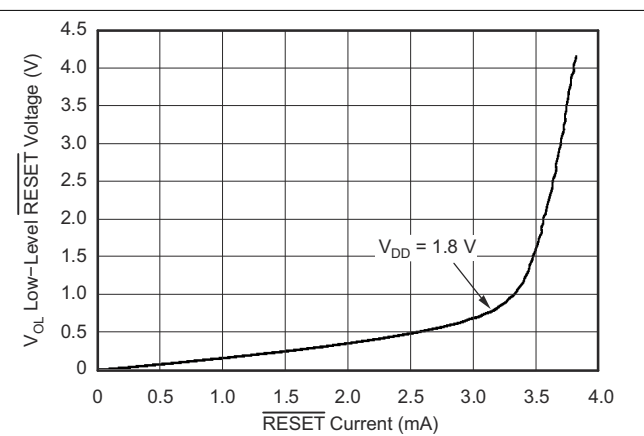

Figure 7-7. Low-Level RESET Voltage vs RESET Current

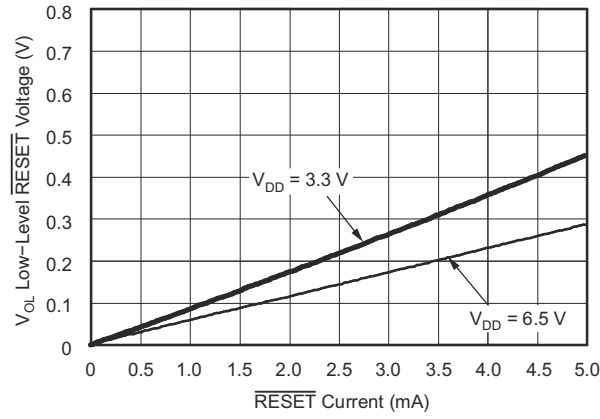

Figure 7-8. Low-Level $\overline{\text{RESET}}$ Voltage vs $\overline{\text{RESET}}$ Current

8 Detailed Description

8.1 Overview

The TPS3808 microprocessor supervisory product family is designed to assert a $\overline{\text{RESET}}$ signal when either the SENSE pin voltage drops below V_{IT} or the manual reset ($\overline{\text{MR}}$) is driven low. The $\overline{\text{RESET}}$ output remains asserted for a user-adjustable time after both the manual reset ($\overline{\text{MR}}$) and SENSE voltages return above their respective thresholds.

8.2 Functional Block Diagram

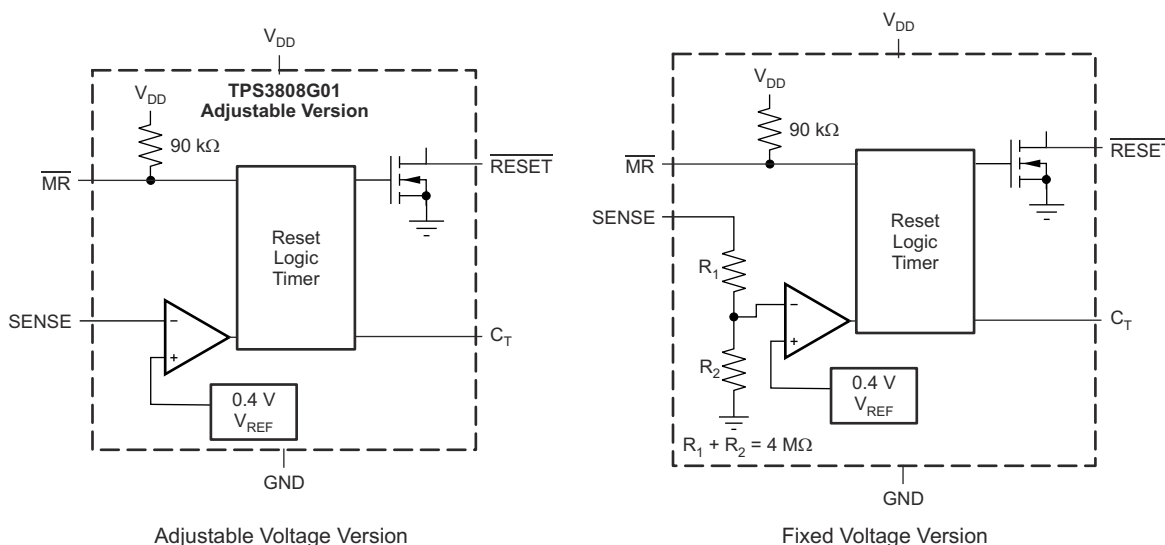

8.3 Feature Description

A broad range of voltage threshold and reset delay time adjustments are available for the TPS3808 device, allowing these devices to be used in a wide array of applications. Reset threshold voltages can be factory-set from 0.82 V to 3.3 V or from 4.4 V to 5 V, while the TPS3808G01 can be set to any voltage above 0.405 V using an external resistor divider. Two preset delay times are also user-selectable: connecting the C_T pin to V_{DD} results in a 300-ms reset delay, whereas leaving the C_T pin open yields a 20-ms reset delay. In addition, connecting a capacitor between C_T and GND allows the designer to select any reset delay period from 1.25 ms to 10 s.

8.3.1 SENSE Input

The SENSE input provides a pin at which any system voltage can be monitored. If the voltage on this pin drops below V_{IT} , then $\overline{\text{RESET}}$ is asserted. The comparator has a built-in hysteresis to ensure smooth $\overline{\text{RESET}}$ assertions and de-assertions. It is good analog design practice to put a 1-nF to 10-nF bypass capacitor on the SENSE input to reduce sensitivity to transients and layout parasitics.

The TPS3808 device is relatively immune to short negative transients on the SENSE pin. Sensitivity to transients is dependent on threshold overdrive, as shown in (Figure 7-5).

The TPS3808G01 can be used to monitor any voltage rail down to 0.405 V using the circuit shown in Figure 8-1.

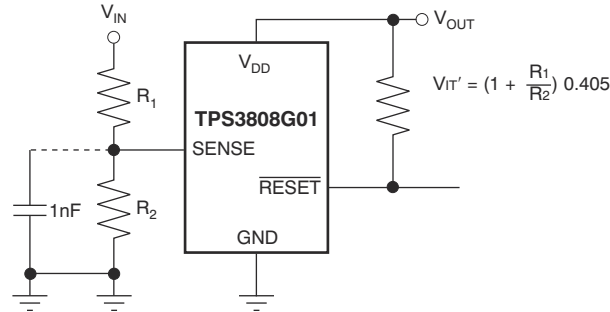

Figure 8-1. Using the TPS3808G01 to Monitor a User-Defined Threshold Voltage

8.3.2 Selecting the RESET Delay Time

The TPS3808 has three options for setting the $\overline{\text{RESET}}$ delay time as shown in Figure 8-2. Figure 8-2 (a) shows the configuration for a fixed 300-ms typical delay time by tying C_T to V_{DD} ; a resistor from 40 k Ω to 200 k Ω must be used. Supply current is not affected by the choice of resistor. Figure 8-2 (b) shows a fixed 20-ms delay time by leaving the C_T pin open. Figure 8-2 (c) shows a ground referenced capacitor connected to C_T for a user-defined program time between 1.25 ms and 10 s.

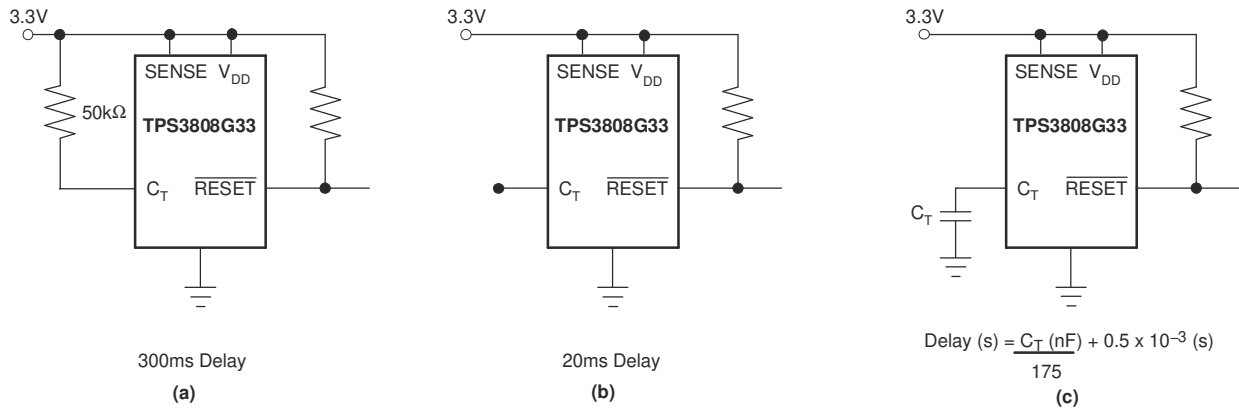

Figure 8-2. Configuration Used to Set the $\overline{\text{RESET}}$ Delay Time

The capacitor C_T should be ≥ 100 pF nominal value in order for the TPS3808xxx to recognize that the capacitor is present. The capacitor value for a given delay time can be calculated using Equation 1.

$$C_T \text{ (nF)} = [t_D \text{ (s)} - 0.5 \times 10^{-3} \text{ (s)}] \times 175 \quad (1)$$

The reset delay time is determined by the time it takes an on-chip precision 220-nA current source to charge the external capacitor to 1.23 V. When a $\overline{\text{RESET}}$ is asserted, the capacitor is discharged. When the $\overline{\text{RESET}}$ conditions are cleared, the internal current source is enabled and begins to charge the external capacitor. When the voltage on this capacitor reaches 1.23 V, $\overline{\text{RESET}}$ is deasserted. Note that a low-leakage type capacitor such as a ceramic should be used, and that stray capacitance around this pin may cause errors in the reset delay time.

8.3.3 Manual RESET (\overline{MR}) Input

The manual reset (\overline{MR}) input allows a processor or other logic circuits to initiate a reset. A logic low ($0.3 V_{DD}$) on \overline{MR} causes \overline{RESET} to assert. After \overline{MR} returns to a logic high and \overline{SENSE} is above its reset threshold, \overline{RESET} is de-asserted after the user-defined reset delay expires. Note that \overline{MR} is internally tied to V_{DD} using a 90-k Ω resistor, so this pin can be left unconnected if \overline{MR} is not used.

See [Figure 8-3](#) for how \overline{MR} can be used to monitor multiple system voltages. Note that if the logic signal driving \overline{MR} does not go fully to V_{DD} , there is some additional current draw into V_{DD} as a result of the internal pullup resistor on \overline{MR} . To minimize current draw, a logic-level FET can be used as illustrated in [Figure 8-4](#).

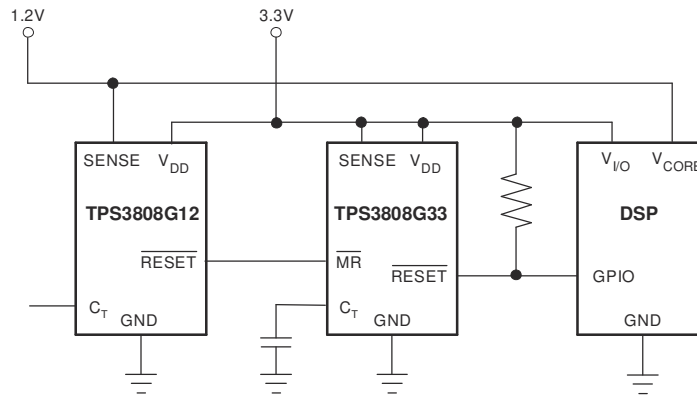

Figure 8-3. Using \overline{MR} to Monitor Multiple System Voltages

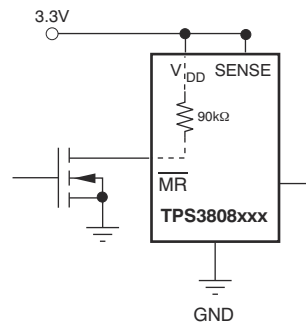

Figure 8-4. Using an External MOSFET to Minimize I_{DD} When \overline{MR} Signal Does Not Go to V_{DD}

8.3.4 RESET Output

\overline{RESET} remains high (unasserted) as long as \overline{SENSE} is above its threshold (V_{IT}) and the manual reset (\overline{MR}) is logic high. If either \overline{SENSE} falls below V_{IT} or \overline{MR} is driven low, \overline{RESET} is asserted, driving the \overline{RESET} pin to a low impedance.

Once \overline{MR} is again logic high and \overline{SENSE} is above $V_{IT} + V_{HYS}$ (the threshold hysteresis), a delay circuit is enabled that holds \overline{RESET} low for a specified reset delay period. Once the reset delay has expired, the \overline{RESET} pin goes to a high impedance state. The pullup resistor from the open-drain \overline{RESET} to the supply line can be used to allow the reset signal for the microprocessor to have a voltage higher than V_{DD} (up to 6.5 V). The pullup resistor should be no smaller than 10 k Ω as a result of the finite impedance of the \overline{RESET} line.

8.4 Device Functional Modes

Table 8-1. Truth Table

MR	SENSE > V _{IT}	RESET
L	0	L
L	1	L
H	0	L
H	1	H

8.4.1 Normal Operation (V_{DD} > V_{DD(min)})

When V_{DD} is greater than V_{DD(min)}, the $\overline{\text{RESET}}$ signal is determined by the voltage on the SENSE pin and the logic state of $\overline{\text{MR}}$.

- $\overline{\text{MR}}$ high: When the voltage on V_{DD} is greater than 1.7 V for a time of the selected t_D, the $\overline{\text{RESET}}$ signal corresponds to the voltage on SENSE relative to V_{IT}.
- $\overline{\text{MR}}$ low: in this mode, $\overline{\text{RESET}}$ is held low regardless of the value of the SENSE pin.

8.4.2 Above Power-On Reset but Less Than V_{DD(min)} (V_{POR} < V_{DD} < V_{DD(min)})

When the voltage on V_{DD} is less than the device V_{DD(min)} voltage, and greater than the power-on reset voltage (V_{POR}), the $\overline{\text{RESET}}$ signal is asserted and low impedance, respectively, regardless of the voltage on the SENSE pin.

8.4.3 Below Power-On Reset (V_{DD} < V_{POR})

When the voltage on V_{DD} is lower than the required voltage (V_{POR}) needed to internally pull the asserted output to GND, $\overline{\text{RESET}}$ is undefined and should not be relied upon for proper device function.

9 Application and Implementation

Note

Information in the following applications sections is not part of the TI component specification, and TI does not warrant its accuracy or completeness. TI's customers are responsible for determining suitability of components for their purposes. Customers should validate and test their design implementation to confirm system functionality.

9.1 Application Information

The following sections describe in detail how to properly use this device, depending on the requirements of the final application.

9.2 Typical Application

A typical application of the TPS3808G25 used with a 2.5-V processor is shown in [Figure 9-1](#). The open-drain $\overline{\text{RESET}}$ output is typically connected to the $\overline{\text{RESET}}$ input of a microprocessor. A pullup resistor must be used to hold this line high when $\overline{\text{RESET}}$ is not asserted. The $\overline{\text{RESET}}$ output is undefined for voltage below 0.8 V, but this characteristic is normally not a problem because most microprocessors do not function below this voltage.

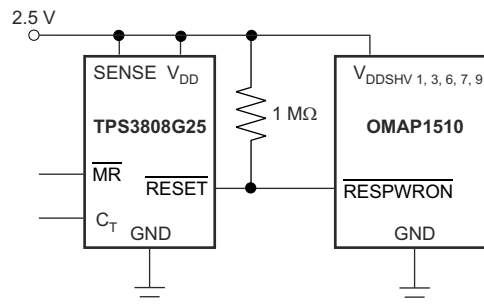

Figure 9-1. Typical Application of the TPS3808 With an OMAP Processor

9.2.1 Design Requirements

The TPS3808 is intended to drive the $\overline{\text{RESET}}$ input of a microprocessor. The $\overline{\text{RESET}}$ pin is pulled high with a 1-M Ω resistor and the reset delay time is controlled by C_T depending on the reset requirement times of the microprocessor. In this case, C_T is left open for a typical reset delay time of 20 ms.

9.2.2 Detailed Design Procedure

The primary constraint for this application is the reset delay time. In this case, because C_T is open, it is set to 20 ms. A 0.1- μF decoupling capacitor is connected to the V_{DD} pin and a 1-M Ω resistor is used to pull up the $\overline{\text{RESET}}$ pin high. The $\overline{\text{MR}}$ pin can be connected to an external signal if desired.

9.2.2.1 Immunity to SENSE Pin Voltage Transients

The TPS3808 is relatively immune to short negative transients on the SENSE pin. Sensitivity to transients depends on threshold overdrive. Threshold overdrive is defined by how much the V_{SENSE} exceeds the specified threshold, and is important to know because the smaller the overdrive, the slower the $\overline{\text{RESET}}$ response. Threshold overdrive is calculated as a percent of the threshold in question, as shown in [Equation 2](#):

$$\text{Overdrive} = | (V_{\text{SENSE}} / V_{\text{IT}} - 1) \times 100\% | \quad (2)$$

where:

- V_{IT} is the threshold voltage.

[Figure 9-2](#) shows this relationship.

9.2.3 Application Curve

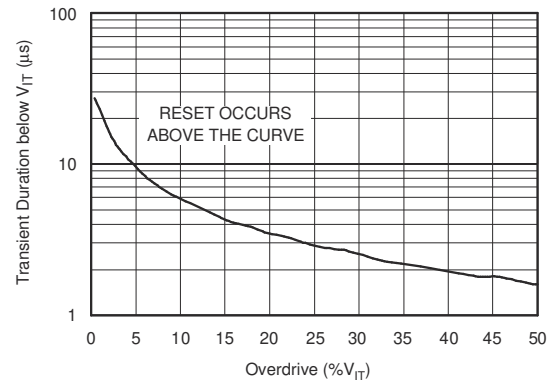

Figure 9-2. Maximum Transient Duration at SENSE vs SENSE Threshold Overdrive Voltage

10 Power Supply Recommendations

These devices are designed to operate from an input supply with a voltage range between 1.7 V and 6.5 V. Use a low-impedance power supply to eliminate inaccuracies caused by current changes during the voltage reference refresh.

11 Layout

11.1 Layout Guidelines

Make sure the connection to the V_{DD} pin is low impedance. Place a 0.1-μF ceramic capacitor near the V_{DD} pin. If no capacitor is connected to the C_T pin, parasitic capacitance on this pin should be minimized so the RESET delay time is not adversely affected.

11.2 Layout Example

The layout example in [Figure 11-1](#) shows how the TPS3808 is laid out on a printed circuit board (PCB) for a 20-ms delay.

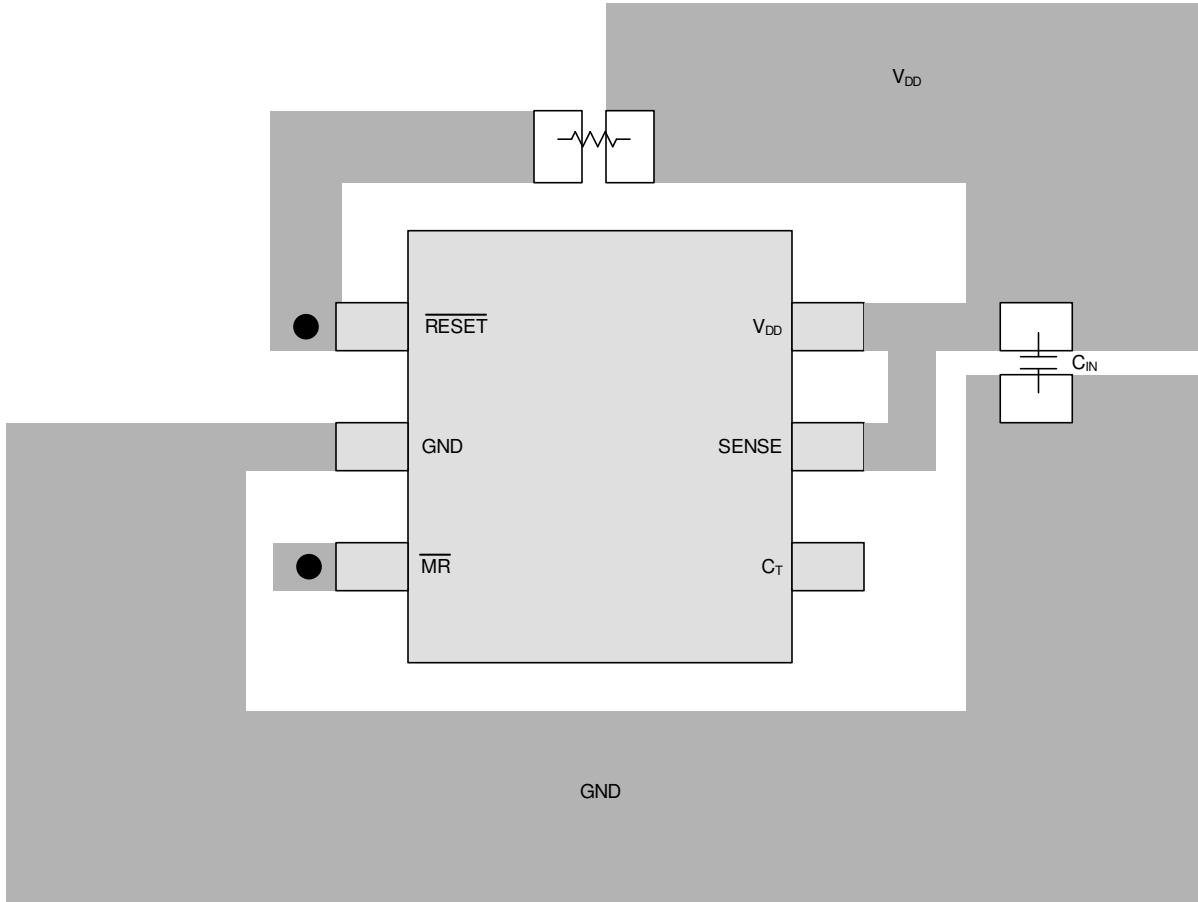

● Vias used to connect pins for application-specific connections

Figure 11-1. Layout Example for a 20-ms Delay

12 Device and Documentation Support

12.1 Device Support

12.1.1 Development Support

12.1.1.1 Evaluation Modules

An evaluation module (EVM) is available to assist in the initial circuit performance evaluation using the TPS3808. The [TPS3808G01DBVEVM evaluation module](#) (and related [user guide](#)) can be requested at the Texas Instruments website through the product folders or purchased directly from the [TI eStore](#).

12.2 Documentation Support

12.2.1 Related Documentation

The following related documents are available for download at [www.ti.com](#):

- Application note. *Optimizing Resistor Dividers at a Comparator Input*. Literature number [SLVA450](#).
- Application note. *Sensitivity Analysis for Power Supply Design*. Literature number [SLVA481](#).
- TPS3808G01DBVEVM Evaluation Module User Guide. Literature number [SBVU015](#).

12.3 Support Resources

[TI E2E™ support forums](#) are an engineer's go-to source for fast, verified answers and design help — straight from the experts. Search existing answers or ask your own question to get the quick design help you need.

Linked content is provided "AS IS" by the respective contributors. They do not constitute TI specifications and do not necessarily reflect TI's views; see TI's [Terms of Use](#).

12.4 Trademarks

TI E2E™ is a trademark of Texas Instruments.

All trademarks are the property of their respective owners.

12.5 Electrostatic Discharge Caution



This integrated circuit can be damaged by ESD. Texas Instruments recommends that all integrated circuits be handled with appropriate precautions. Failure to observe proper handling and installation procedures can cause damage.

ESD damage can range from subtle performance degradation to complete device failure. Precision integrated circuits may be more susceptible to damage because very small parametric changes could cause the device not to meet its published specifications.

12.6 Glossary

[TI Glossary](#) This glossary lists and explains terms, acronyms, and definitions.

13 Mechanical, Packaging, and Orderable Information

The following pages include mechanical, packaging, and orderable information. This information is the most-current data available for the designated devices. This data is subject to change without notice and without revision of this document. For browser-based versions of this data sheet, see the left-hand navigation pane.

PACKAGING INFORMATION

Orderable Device	Status (1)	Package Type	Package Drawing	Pins	Package Qty	Eco Plan (2)	Lead finish/ Ball material (6)	MSL Peak Temp (3)	Op Temp (°C)	Device Marking (4/5)	Samples
TPS3808G01DBVR	ACTIVE	SOT-23	DBV	6	3000	RoHS & Green	NIPDAU	Level-1-260C-UNLIM	-40 to 125	AVW	Samples
TPS3808G01DBVRG4	ACTIVE	SOT-23	DBV	6	3000	TBD	Call TI	Call TI	-40 to 125		Samples
TPS3808G01DBVT	ACTIVE	SOT-23	DBV	6	250	RoHS & Green	NIPDAU	Level-1-260C-UNLIM	-40 to 125	AVW	Samples
TPS3808G01DBVTG4	ACTIVE	SOT-23	DBV	6	250	TBD	Call TI	Call TI	-40 to 125		Samples
TPS3808G01DRVR	ACTIVE	WSON	DRV	6	3000	RoHS & Green	NIPDAU	Level-1-260C-UNLIM	-40 to 125	AVW	Samples
TPS3808G01DRVRG4	ACTIVE	WSON	DRV	6	3000	TBD	Call TI	Call TI	-40 to 125		Samples
TPS3808G01DRVT	ACTIVE	WSON	DRV	6	250	RoHS & Green	NIPDAU	Level-1-260C-UNLIM	-40 to 125	AVW	Samples
TPS3808G09DBVR	ACTIVE	SOT-23	DBV	6	3000	RoHS & Green	NIPDAU	Level-1-260C-UNLIM	-40 to 125	AVV	Samples
TPS3808G09DBVRG4	ACTIVE	SOT-23	DBV	6	3000	TBD	Call TI	Call TI	-40 to 125		Samples
TPS3808G09DBVT	ACTIVE	SOT-23	DBV	6	250	RoHS & Green	NIPDAU	Level-1-260C-UNLIM	-40 to 125	AVV	Samples
TPS3808G09DBVTG4	ACTIVE	SOT-23	DBV	6	250	TBD	Call TI	Call TI	-40 to 125		Samples
TPS3808G125DBVR	ACTIVE	SOT-23	DBV	6	3000	RoHS & Green	NIPDAU	Level-1-260C-UNLIM	-40 to 125	CAC	Samples
TPS3808G125DBVT	ACTIVE	SOT-23	DBV	6	250	RoHS & Green	NIPDAU	Level-1-260C-UNLIM	-40 to 125	CAC	Samples
TPS3808G125DBVTG4	ACTIVE	SOT-23	DBV	6	250	TBD	Call TI	Call TI	-40 to 125		Samples
TPS3808G12DBVR	ACTIVE	SOT-23	DBV	6	3000	RoHS & Green	NIPDAU	Level-1-260C-UNLIM	-40 to 125	AVY	Samples
TPS3808G12DBVRG4	ACTIVE	SOT-23	DBV	6	3000	TBD	Call TI	Call TI	-40 to 125		Samples
TPS3808G12DBVT	ACTIVE	SOT-23	DBV	6	250	RoHS & Green	NIPDAU	Level-1-260C-UNLIM	-40 to 125	AVY	Samples
TPS3808G12DBVTG4	ACTIVE	SOT-23	DBV	6	250	TBD	Call TI	Call TI	-40 to 125		Samples
TPS3808G12DRVR	ACTIVE	WSON	DRV	6	3000	RoHS & Green	NIPDAU NIPDAUAG	Level-1-260C-UNLIM	-40 to 125	AVY	Samples
TPS3808G12DRVT	ACTIVE	WSON	DRV	6	250	RoHS & Green	NIPDAU NIPDAUAG	Level-1-260C-UNLIM	-40 to 125	AVY	Samples

Orderable Device	Status (1)	Package Type	Package Drawing	Pins	Package Qty	Eco Plan (2)	Lead finish/ Ball material (6)	MSL Peak Temp (3)	Op Temp (°C)	Device Marking (4/5)	Samples
TPS3808G12DRVVG4	ACTIVE	WSO	DRV	6	250	TBD	Call TI	Call TI	-40 to 125		Samples
TPS3808G15DBVR	ACTIVE	SOT-23	DBV	6	3000	RoHS & Green	NIPDAU	Level-1-260C-UNLIM	-40 to 125	AVS	Samples
TPS3808G15DBVRG4	ACTIVE	SOT-23	DBV	6	3000	TBD	Call TI	Call TI	-40 to 125		Samples
TPS3808G15DBVT	ACTIVE	SOT-23	DBV	6	250	RoHS & Green	NIPDAU	Level-1-260C-UNLIM	-40 to 125	AVS	Samples
TPS3808G15DBVTG4	ACTIVE	SOT-23	DBV	6	250	TBD	Call TI	Call TI	-40 to 125		Samples
TPS3808G15DRVR	ACTIVE	WSO	DRV	6	3000	RoHS & Green	NIPDAU	Level-1-260C-UNLIM	-40 to 125	AVS	Samples
TPS3808G15DRVT	ACTIVE	WSO	DRV	6	250	RoHS & Green	NIPDAU	Level-1-260C-UNLIM	-40 to 125	AVS	Samples
TPS3808G18DBVR	ACTIVE	SOT-23	DBV	6	3000	RoHS & Green	NIPDAU	Level-1-260C-UNLIM	-40 to 125	AVR	Samples
TPS3808G18DBVRG4	ACTIVE	SOT-23	DBV	6	3000	TBD	Call TI	Call TI	-40 to 125		Samples
TPS3808G18DBVT	ACTIVE	SOT-23	DBV	6	250	RoHS & Green	NIPDAU	Level-1-260C-UNLIM	-40 to 125	AVR	Samples
TPS3808G18DBVTG4	ACTIVE	SOT-23	DBV	6	250	TBD	Call TI	Call TI	-40 to 125		Samples
TPS3808G18DRVR	ACTIVE	WSO	DRV	6	3000	RoHS & Green	NIPDAU	Level-1-260C-UNLIM	-40 to 125	AVR	Samples
TPS3808G18DRVT	ACTIVE	WSO	DRV	6	250	RoHS & Green	NIPDAU	Level-1-260C-UNLIM	-40 to 125	AVR	Samples
TPS3808G19DBVR	ACTIVE	SOT-23	DBV	6	3000	RoHS & Green	NIPDAU	Level-1-260C-UNLIM	-40 to 125	CHP	Samples
TPS3808G19DBVT	ACTIVE	SOT-23	DBV	6	250	RoHS & Green	NIPDAU	Level-1-260C-UNLIM	-40 to 125	CHP	Samples
TPS3808G25DBVR	ACTIVE	SOT-23	DBV	6	3000	RoHS & Green	NIPDAU	Level-1-260C-UNLIM	-40 to 125	(AVQ, EG25)	Samples
TPS3808G25DBVRG4	ACTIVE	SOT-23	DBV	6	3000	TBD	Call TI	Call TI	-40 to 125		Samples
TPS3808G25DBVT	ACTIVE	SOT-23	DBV	6	250	RoHS & Green	NIPDAU	Level-1-260C-UNLIM	-40 to 125	AVQ	Samples
TPS3808G25DBVTG4	ACTIVE	SOT-23	DBV	6	250	TBD	Call TI	Call TI	-40 to 125		Samples
TPS3808G25DRVR	ACTIVE	WSO	DRV	6	3000	RoHS & Green	NIPDAU	Level-1-260C-UNLIM	-40 to 125	AVQ	Samples
TPS3808G25DRVT	ACTIVE	WSO	DRV	6	250	RoHS & Green	NIPDAU	Level-1-260C-UNLIM	-40 to 125	AVQ	Samples

Orderable Device	Status (1)	Package Type	Package Drawing	Pins	Package Qty	Eco Plan (2)	Lead finish/ Ball material (6)	MSL Peak Temp (3)	Op Temp (°C)	Device Marking (4/5)	Samples
TPS3808G30DBVR	ACTIVE	SOT-23	DBV	6	3000	RoHS & Green	NIPDAU	Level-1-260C-UNLIM	-40 to 125	AVP	Samples
TPS3808G30DBVRG4	ACTIVE	SOT-23	DBV	6	3000	TBD	Call TI	Call TI	-40 to 125		Samples
TPS3808G30DBVT	ACTIVE	SOT-23	DBV	6	250	RoHS & Green	NIPDAU	Level-1-260C-UNLIM	-40 to 125	AVP	Samples
TPS3808G30DBVTG4	ACTIVE	SOT-23	DBV	6	250	TBD	Call TI	Call TI	-40 to 125		Samples
TPS3808G30DRVR	ACTIVE	WSON	DRV	6	3000	RoHS & Green	NIPDAU NIPDAUAG	Level-1-260C-UNLIM	-40 to 125	AVP	Samples
TPS3808G30DRVT	ACTIVE	WSON	DRV	6	250	RoHS & Green	NIPDAU NIPDAUAG	Level-1-260C-UNLIM	-40 to 125	AVP	Samples
TPS3808G33DBVR	ACTIVE	SOT-23	DBV	6	3000	RoHS & Green	NIPDAU	Level-1-260C-UNLIM	-40 to 125	AVO	Samples
TPS3808G33DBVRG4	ACTIVE	SOT-23	DBV	6	3000	TBD	Call TI	Call TI	-40 to 125		Samples
TPS3808G33DBVT	ACTIVE	SOT-23	DBV	6	250	RoHS & Green	NIPDAU	Level-1-260C-UNLIM	-40 to 125	AVO	Samples
TPS3808G33DBVTG4	ACTIVE	SOT-23	DBV	6	250	TBD	Call TI	Call TI	-40 to 125		Samples
TPS3808G33DRVR	ACTIVE	WSON	DRV	6	3000	RoHS & Green	NIPDAU	Level-1-260C-UNLIM	-40 to 125	SEC	Samples
TPS3808G33DRVT	ACTIVE	WSON	DRV	6	250	RoHS & Green	NIPDAU	Level-1-260C-UNLIM	-40 to 125	SEC	Samples
TPS3808G50DBVR	ACTIVE	SOT-23	DBV	6	3000	RoHS & Green	NIPDAU	Level-1-260C-UNLIM	-40 to 125	AVN	Samples
TPS3808G50DBVRG4	ACTIVE	SOT-23	DBV	6	3000	TBD	Call TI	Call TI	-40 to 125		Samples
TPS3808G50DBVT	ACTIVE	SOT-23	DBV	6	250	RoHS & Green	NIPDAU	Level-1-260C-UNLIM	-40 to 125	AVN	Samples
TPS3808G50DBVTG4	ACTIVE	SOT-23	DBV	6	250	TBD	Call TI	Call TI	-40 to 125		Samples

(1) The marketing status values are defined as follows:

ACTIVE: Product device recommended for new designs.

LIFEBUY: TI has announced that the device will be discontinued, and a lifetime-buy period is in effect.

NRND: Not recommended for new designs. Device is in production to support existing customers, but TI does not recommend using this part in a new design.

PREVIEW: Device has been announced but is not in production. Samples may or may not be available.

OBSELETE: TI has discontinued the production of the device.

(2) **RoHS:** TI defines "RoHS" to mean semiconductor products that are compliant with the current EU RoHS requirements for all 10 RoHS substances, including the requirement that RoHS substance do not exceed 0.1% by weight in homogeneous materials. Where designed to be soldered at high temperatures, "RoHS" products are suitable for use in specified lead-free processes. TI may reference these types of products as "Pb-Free".

RoHS Exempt: TI defines "RoHS Exempt" to mean products that contain lead but are compliant with EU RoHS pursuant to a specific EU RoHS exemption.

Green: TI defines "Green" to mean the content of Chlorine (Cl) and Bromine (Br) based flame retardants meet JS709B low halogen requirements of ≤ 1000 ppm threshold. Antimony trioxide based flame retardants must also meet the ≤ 1000 ppm threshold requirement.

(3) MSL, Peak Temp. - The Moisture Sensitivity Level rating according to the JEDEC industry standard classifications, and peak solder temperature.

(4) There may be additional marking, which relates to the logo, the lot trace code information, or the environmental category on the device.

(5) Multiple Device Markings will be inside parentheses. Only one Device Marking contained in parentheses and separated by a "~" will appear on a device. If a line is indented then it is a continuation of the previous line and the two combined represent the entire Device Marking for that device.

(6) Lead finish/Ball material - Orderable Devices may have multiple material finish options. Finish options are separated by a vertical ruled line. Lead finish/Ball material values may wrap to two lines if the finish value exceeds the maximum column width.

Important Information and Disclaimer: The information provided on this page represents TI's knowledge and belief as of the date that it is provided. TI bases its knowledge and belief on information provided by third parties, and makes no representation or warranty as to the accuracy of such information. Efforts are underway to better integrate information from third parties. TI has taken and continues to take reasonable steps to provide representative and accurate information but may not have conducted destructive testing or chemical analysis on incoming materials and chemicals. TI and TI suppliers consider certain information to be proprietary, and thus CAS numbers and other limited information may not be available for release.

In no event shall TI's liability arising out of such information exceed the total purchase price of the TI part(s) at issue in this document sold by TI to Customer on an annual basis.

OTHER QUALIFIED VERSIONS OF TPS3808 :

- Automotive : [TPS3808-Q1](#)
- Enhanced Product : [TPS3808-EP](#)

NOTE: Qualified Version Definitions:

- Automotive - Q100 devices qualified for high-reliability automotive applications targeting zero defects
- Enhanced Product - Supports Defense, Aerospace and Medical Applications

TAPE AND REEL INFORMATION

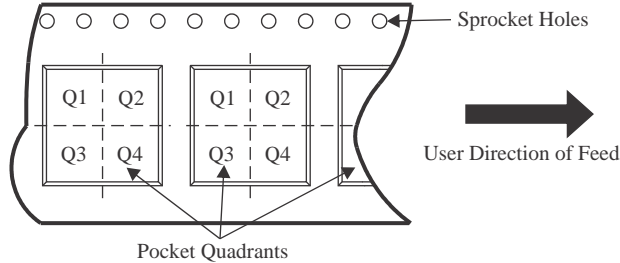
QUADRANT ASSIGNMENTS FOR PIN 1 ORIENTATION IN TAPE

*All dimensions are nominal

Device	Package Type	Package Drawing	Pins	SPQ	Reel Diameter (mm)	Reel Width W1 (mm)	A0 (mm)	B0 (mm)	K0 (mm)	P1 (mm)	W (mm)	Pin1 Quadrant
TPS3808G01DBVR	SOT-23	DBV	6	3000	180.0	8.4	3.2	3.2	1.4	4.0	8.0	Q3
TPS3808G01DBVT	SOT-23	DBV	6	250	180.0	8.4	3.2	3.2	1.4	4.0	8.0	Q3
TPS3808G01DRVR	WSO	DRV	6	3000	178.0	8.4	2.25	2.25	1.0	4.0	8.0	Q2
TPS3808G01DRVT	WSO	DRV	6	250	178.0	8.4	2.25	2.25	1.0	4.0	8.0	Q2
TPS3808G01DRVT	WSO	DRV	6	250	179.0	8.4	2.2	2.2	1.2	4.0	8.0	Q2
TPS3808G09DBVR	SOT-23	DBV	6	3000	180.0	8.4	3.2	3.2	1.4	4.0	8.0	Q3
TPS3808G09DBVT	SOT-23	DBV	6	250	180.0	8.4	3.2	3.2	1.4	4.0	8.0	Q3
TPS3808G125DBVR	SOT-23	DBV	6	3000	179.0	8.4	3.2	3.2	1.4	4.0	8.0	Q3
TPS3808G125DBVT	SOT-23	DBV	6	250	179.0	8.4	3.2	3.2	1.4	4.0	8.0	Q3
TPS3808G12DBVR	SOT-23	DBV	6	3000	178.0	9.0	3.23	3.17	1.37	4.0	8.0	Q3
TPS3808G12DBVT	SOT-23	DBV	6	250	178.0	9.0	3.23	3.17	1.37	4.0	8.0	Q3
TPS3808G12DRVR	WSO	DRV	6	3000	179.0	8.4	2.2	2.2	1.2	4.0	8.0	Q2
TPS3808G12DRVR	WSO	DRV	6	3000	178.0	8.4	2.25	2.25	1.0	4.0	8.0	Q2
TPS3808G12DRVT	WSO	DRV	6	250	178.0	8.4	2.25	2.25	1.0	4.0	8.0	Q2
TPS3808G12DRVT	WSO	DRV	6	250	179.0	8.4	2.2	2.2	1.2	4.0	8.0	Q2
TPS3808G15DBVR	SOT-23	DBV	6	3000	178.0	9.0	3.23	3.17	1.37	4.0	8.0	Q3

Device	Package Type	Package Drawing	Pins	SPQ	Reel Diameter (mm)	Reel Width W1 (mm)	A0 (mm)	B0 (mm)	K0 (mm)	P1 (mm)	W (mm)	Pin1 Quadrant
TPS3808G15DBVT	SOT-23	DBV	6	250	178.0	9.0	3.23	3.17	1.37	4.0	8.0	Q3
TPS3808G15DRVR	WSON	DRV	6	3000	179.0	8.4	2.2	2.2	1.2	4.0	8.0	Q2
TPS3808G15DRVT	WSON	DRV	6	250	179.0	8.4	2.2	2.2	1.2	4.0	8.0	Q2
TPS3808G18DBVR	SOT-23	DBV	6	3000	180.0	8.4	3.2	3.2	1.4	4.0	8.0	Q3
TPS3808G18DBVT	SOT-23	DBV	6	250	180.0	8.4	3.2	3.2	1.4	4.0	8.0	Q3
TPS3808G18DRVR	WSON	DRV	6	3000	179.0	8.4	2.2	2.2	1.2	4.0	8.0	Q2
TPS3808G18DRVT	WSON	DRV	6	250	179.0	8.4	2.2	2.2	1.2	4.0	8.0	Q2
TPS3808G19DBVR	SOT-23	DBV	6	3000	178.0	9.0	3.23	3.17	1.37	4.0	8.0	Q3
TPS3808G19DBVT	SOT-23	DBV	6	250	178.0	9.0	3.23	3.17	1.37	4.0	8.0	Q3
TPS3808G25DBVR	SOT-23	DBV	6	3000	178.0	9.0	3.23	3.17	1.37	4.0	8.0	Q3
TPS3808G25DBVT	SOT-23	DBV	6	250	178.0	9.0	3.23	3.17	1.37	4.0	8.0	Q3
TPS3808G25DRVR	WSON	DRV	6	3000	179.0	8.4	2.2	2.2	1.2	4.0	8.0	Q2
TPS3808G25DRVT	WSON	DRV	6	250	179.0	8.4	2.2	2.2	1.2	4.0	8.0	Q2
TPS3808G30DBVR	SOT-23	DBV	6	3000	180.0	8.4	3.2	3.2	1.4	4.0	8.0	Q3
TPS3808G30DBVT	SOT-23	DBV	6	250	180.0	8.4	3.2	3.2	1.4	4.0	8.0	Q3
TPS3808G30DRVR	WSON	DRV	6	3000	179.0	8.4	2.2	2.2	1.2	4.0	8.0	Q2
TPS3808G30DRVT	WSON	DRV	6	3000	178.0	8.4	2.25	2.25	1.0	4.0	8.0	Q2
TPS3808G30DRVT	WSON	DRV	6	250	178.0	8.4	2.25	2.25	1.0	4.0	8.0	Q2
TPS3808G30DRVT	WSON	DRV	6	250	179.0	8.4	2.2	2.2	1.2	4.0	8.0	Q2
TPS3808G33DBVR	SOT-23	DBV	6	3000	178.0	9.0	3.23	3.17	1.37	4.0	8.0	Q3
TPS3808G33DBVT	SOT-23	DBV	6	250	178.0	9.0	3.23	3.17	1.37	4.0	8.0	Q3
TPS3808G33DRVR	WSON	DRV	6	3000	179.0	8.4	2.2	2.2	1.2	4.0	8.0	Q2
TPS3808G33DRVT	WSON	DRV	6	250	179.0	8.4	2.2	2.2	1.2	4.0	8.0	Q2
TPS3808G50DBVR	SOT-23	DBV	6	3000	178.0	9.0	3.23	3.17	1.37	4.0	8.0	Q3
TPS3808G50DBVT	SOT-23	DBV	6	250	178.0	9.0	3.23	3.17	1.37	4.0	8.0	Q3

TAPE AND REEL BOX DIMENSIONS

*All dimensions are nominal

Device	Package Type	Package Drawing	Pins	SPQ	Length (mm)	Width (mm)	Height (mm)
TPS3808G01DBVR	SOT-23	DBV	6	3000	210.0	185.0	35.0
TPS3808G01DBVT	SOT-23	DBV	6	250	210.0	185.0	35.0
TPS3808G01DRVR	WSON	DRV	6	3000	205.0	200.0	33.0
TPS3808G01DRVT	WSON	DRV	6	250	205.0	200.0	33.0
TPS3808G01DRVT	WSON	DRV	6	250	203.0	203.0	35.0
TPS3808G09DBVR	SOT-23	DBV	6	3000	210.0	185.0	35.0
TPS3808G09DBVT	SOT-23	DBV	6	250	210.0	185.0	35.0
TPS3808G125DBVR	SOT-23	DBV	6	3000	200.0	183.0	25.0
TPS3808G125DBVT	SOT-23	DBV	6	250	200.0	183.0	25.0
TPS3808G12DBVR	SOT-23	DBV	6	3000	180.0	180.0	18.0
TPS3808G12DBVT	SOT-23	DBV	6	250	180.0	180.0	18.0
TPS3808G12DRVR	WSON	DRV	6	3000	200.0	183.0	25.0
TPS3808G12DRVR	WSON	DRV	6	3000	205.0	200.0	33.0
TPS3808G12DRVT	WSON	DRV	6	250	205.0	200.0	33.0
TPS3808G12DRVT	WSON	DRV	6	250	203.0	203.0	35.0
TPS3808G15DBVR	SOT-23	DBV	6	3000	180.0	180.0	18.0
TPS3808G15DBVT	SOT-23	DBV	6	250	180.0	180.0	18.0
TPS3808G15DRVR	WSON	DRV	6	3000	200.0	183.0	25.0

Device	Package Type	Package Drawing	Pins	SPQ	Length (mm)	Width (mm)	Height (mm)
TPS3808G15DRV T	WSON	DRV	6	250	200.0	183.0	25.0
TPS3808G18DBV R	SOT-23	DBV	6	3000	210.0	185.0	35.0
TPS3808G18DBV T	SOT-23	DBV	6	250	210.0	185.0	35.0
TPS3808G18DRV R	WSON	DRV	6	3000	200.0	183.0	25.0
TPS3808G18DRV T	WSON	DRV	6	250	200.0	183.0	25.0
TPS3808G19DBV R	SOT-23	DBV	6	3000	180.0	180.0	18.0
TPS3808G19DBV T	SOT-23	DBV	6	250	180.0	180.0	18.0
TPS3808G25DBV R	SOT-23	DBV	6	3000	180.0	180.0	18.0
TPS3808G25DBV T	SOT-23	DBV	6	250	180.0	180.0	18.0
TPS3808G25DRV R	WSON	DRV	6	3000	203.0	203.0	35.0
TPS3808G25DRV T	WSON	DRV	6	250	200.0	183.0	25.0
TPS3808G30DBV R	SOT-23	DBV	6	3000	210.0	185.0	35.0
TPS3808G30DBV T	SOT-23	DBV	6	250	210.0	185.0	35.0
TPS3808G30DRV R	WSON	DRV	6	3000	203.0	203.0	35.0
TPS3808G30DRV R	WSON	DRV	6	3000	205.0	200.0	33.0
TPS3808G30DRV T	WSON	DRV	6	250	205.0	200.0	33.0
TPS3808G30DRV T	WSON	DRV	6	250	203.0	203.0	35.0
TPS3808G33DBV R	SOT-23	DBV	6	3000	180.0	180.0	18.0
TPS3808G33DBV T	SOT-23	DBV	6	250	180.0	180.0	18.0
TPS3808G33DRV R	WSON	DRV	6	3000	200.0	183.0	25.0
TPS3808G33DRV T	WSON	DRV	6	250	200.0	183.0	25.0
TPS3808G50DBV R	SOT-23	DBV	6	3000	180.0	180.0	18.0
TPS3808G50DBV T	SOT-23	DBV	6	250	180.0	180.0	18.0

GENERIC PACKAGE VIEW

DRV 6

WSON - 0.8 mm max height

PLASTIC SMALL OUTLINE - NO LEAD



Images above are just a representation of the package family, actual package may vary.
Refer to the product data sheet for package details.

4206925/F

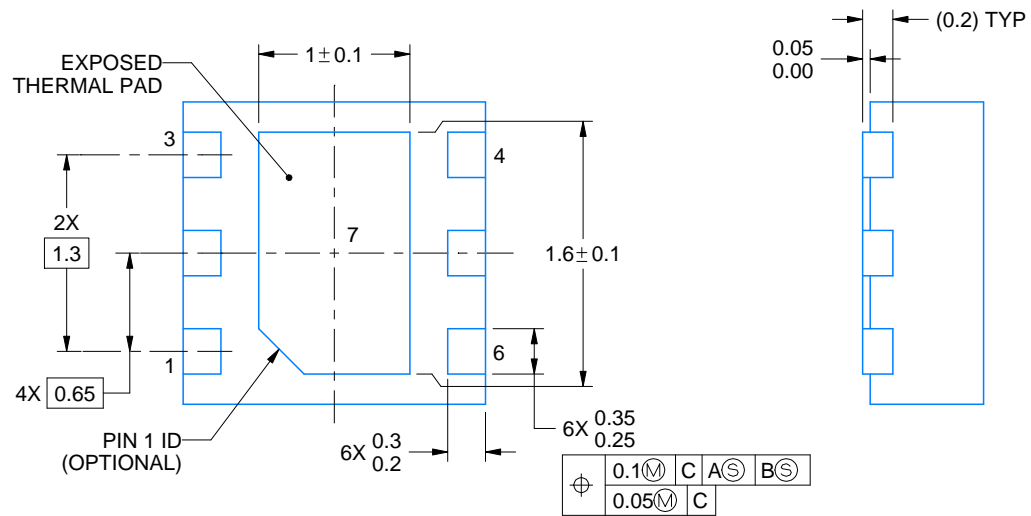
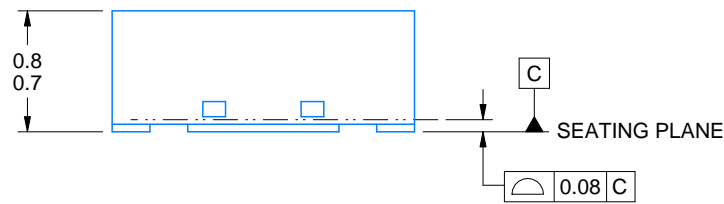
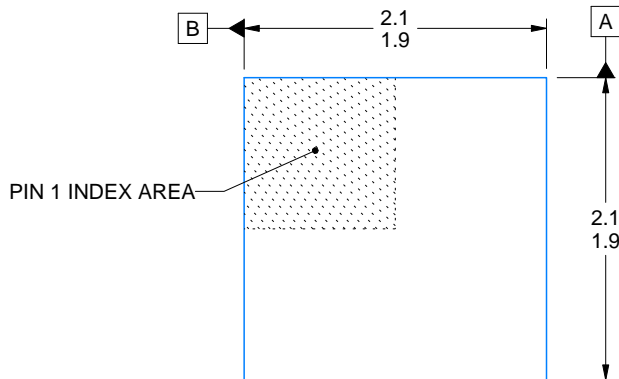
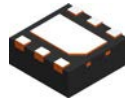

4222173/B 04/2018

NOTES:

1. All linear dimensions are in millimeters. Any dimensions in parenthesis are for reference only. Dimensioning and tolerancing per ASME Y14.5M.
2. This drawing is subject to change without notice.
3. The package thermal pad must be soldered to the printed circuit board for thermal and mechanical performance.

EXAMPLE STENCIL DESIGN

DRV0006A

WSON - 0.8 mm max height

PLASTIC SMALL OUTLINE - NO LEAD



SOLDER PASTE EXAMPLE
BASED ON 0.125 mm THICK STENCIL

EXPOSED PAD #7
88% PRINTED SOLDER COVERAGE BY AREA UNDER PACKAGE
SCALE:30X

4222173/B 04/2018

NOTES: (continued)

6. Laser cutting apertures with trapezoidal walls and rounded corners may offer better paste release. IPC-7525 may have alternate design recommendations.

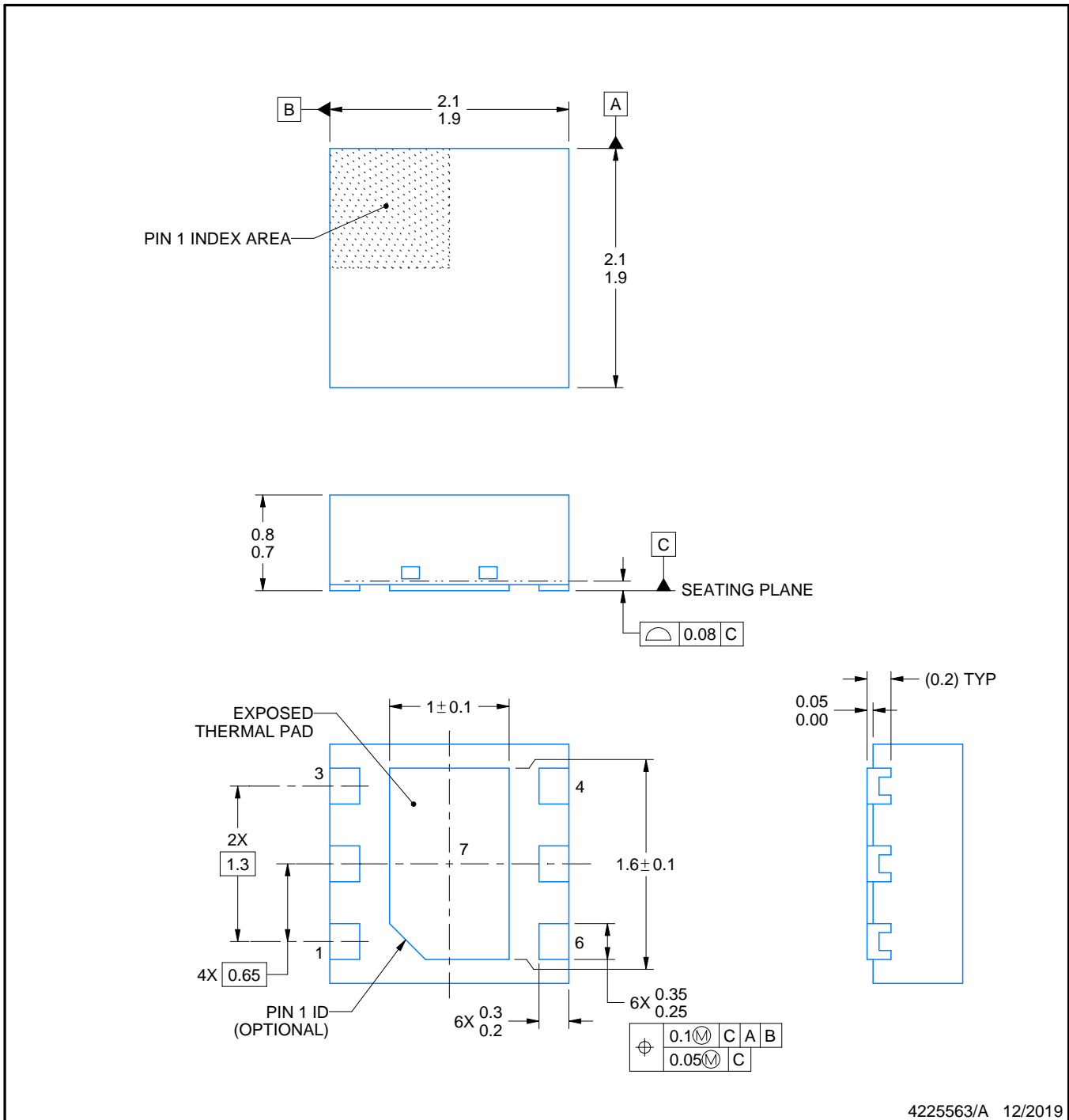

NOTES:

1. All linear dimensions are in millimeters. Any dimensions in parenthesis are for reference only. Dimensioning and tolerancing per ASME Y14.5M.
2. This drawing is subject to change without notice.
3. The package thermal pad must be soldered to the printed circuit board for thermal and mechanical performance.

EXAMPLE BOARD LAYOUT

DRV0006D

WSON - 0.8 mm max height

PLASTIC SMALL OUTLINE - NO LEAD



LAND PATTERN EXAMPLE
EXPOSED METAL SHOWN
SCALE:25X



SOLDER MASK DETAILS

4225563/A 12/2019

NOTES: (continued)

4. This package is designed to be soldered to a thermal pad on the board. For more information, see Texas Instruments literature number SLUA271 (www.ti.com/lit/sluea271).
5. Vias are optional depending on application, refer to device data sheet. If some or all are implemented, recommended via locations are shown.

EXAMPLE STENCIL DESIGN

DRV0006D

WSON - 0.8 mm max height

PLASTIC SMALL OUTLINE - NO LEAD



SOLDER PASTE EXAMPLE
BASED ON 0.125 mm THICK STENCIL

EXPOSED PAD #7
88% PRINTED SOLDER COVERAGE BY AREA UNDER PACKAGE
SCALE:30X

4225563/A 12/2019

NOTES: (continued)

6. Laser cutting apertures with trapezoidal walls and rounded corners may offer better paste release. IPC-7525 may have alternate design recommendations.

EXAMPLE BOARD LAYOUT

DBV0006A

SOT-23 - 1.45 mm max height

SMALL OUTLINE TRANSISTOR

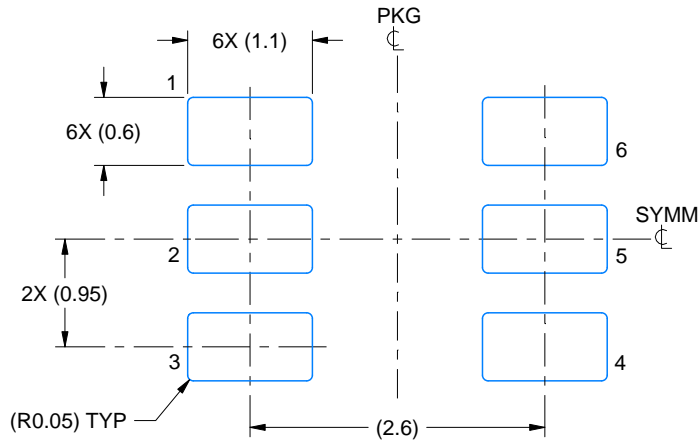

LAND PATTERN EXAMPLE
EXPOSED METAL SHOWN
SCALE:15X

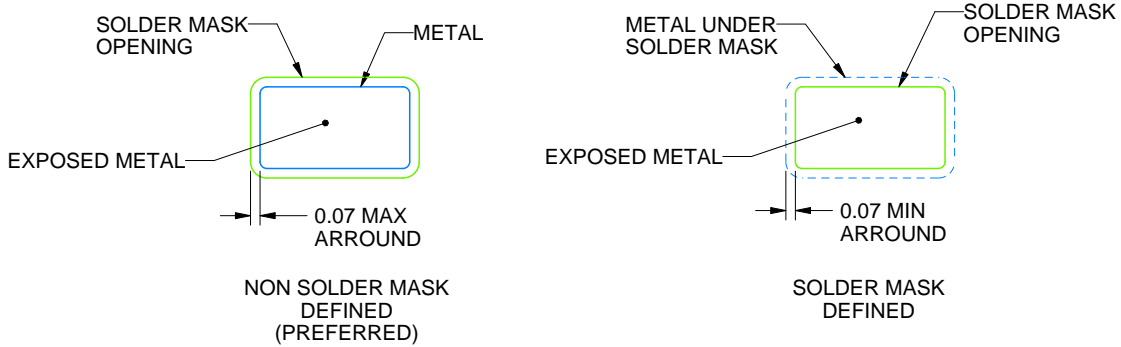

SOLDER MASK DETAILS

4214840/E 02/2024

NOTES: (continued)

6. Publication IPC-7351 may have alternate designs.

7. Solder mask tolerances between and around signal pads can vary based on board fabrication site.

EXAMPLE STENCIL DESIGN

DBV0006A

SOT-23 - 1.45 mm max height

SMALL OUTLINE TRANSISTOR

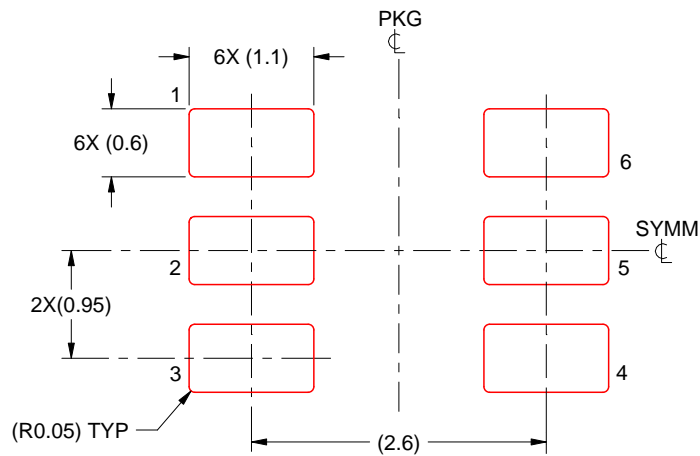

SOLDER PASTE EXAMPLE
BASED ON 0.125 mm THICK STENCIL
SCALE:15X

4214840/E 02/2024

NOTES: (continued)

8. Laser cutting apertures with trapezoidal walls and rounded corners may offer better paste release. IPC-7525 may have alternate design recommendations.
9. Board assembly site may have different recommendations for stencil design.

IMPORTANT NOTICE AND DISCLAIMER

TI PROVIDES TECHNICAL AND RELIABILITY DATA (INCLUDING DATA SHEETS), DESIGN RESOURCES (INCLUDING REFERENCE DESIGNS), APPLICATION OR OTHER DESIGN ADVICE, WEB TOOLS, SAFETY INFORMATION, AND OTHER RESOURCES "AS IS" AND WITH ALL FAULTS, AND DISCLAIMS ALL WARRANTIES, EXPRESS AND IMPLIED, INCLUDING WITHOUT LIMITATION ANY IMPLIED WARRANTIES OF MERCHANTABILITY, FITNESS FOR A PARTICULAR PURPOSE OR NON-INFRINGEMENT OF THIRD PARTY INTELLECTUAL PROPERTY RIGHTS.

These resources are intended for skilled developers designing with TI products. You are solely responsible for (1) selecting the appropriate TI products for your application, (2) designing, validating and testing your application, and (3) ensuring your application meets applicable standards, and any other safety, security, regulatory or other requirements.

These resources are subject to change without notice. TI grants you permission to use these resources only for development of an application that uses the TI products described in the resource. Other reproduction and display of these resources is prohibited. No license is granted to any other TI intellectual property right or to any third party intellectual property right. TI disclaims responsibility for, and you will fully indemnify TI and its representatives against, any claims, damages, costs, losses, and liabilities arising out of your use of these resources.

TI's products are provided subject to [TI's Terms of Sale](#) or other applicable terms available either on [ti.com](https://www.ti.com) or provided in conjunction with such TI products. TI's provision of these resources does not expand or otherwise alter TI's applicable warranties or warranty disclaimers for TI products.

TI objects to and rejects any additional or different terms you may have proposed.

Mailing Address: Texas Instruments, Post Office Box 655303, Dallas, Texas 75265
Copyright © 2024, Texas Instruments Incorporated

Looking for pricing, stock, or lifecycle information?

Click below to explore more details on WIN SOURCE:

 [View TPS3808G18DBVR on WIN SOURCE](#)

 [Texas Instruments](#) Information

Optimize Your Supply Chain with WIN SOURCE Solutions

-  Global Sourcing Solution
-  Obsolete Management
-  Cost Control Management
-  Shortage Management
-  Alternative Solution
-  Excess Inventory Management