



**THE DATASHEET OF
TPS40077PWPR**



TPS40077 4.5-V to 28-V Input, Voltage Mode, Synchronous Buck Controller With Voltage Feed Forward

1 Features

- Operation Over 4.5-V to 28-V Input Range
- Programmable, Fixed-Frequency, up to 1-MHz, Voltage-Mode Controller
- Predictive Gate-Drive Anti-Cross-Conduction Circuitry
- <1% Internal 700-mV Reference
- Internal Gate-Drive Outputs for High-Side and Synchronous N-Channel MOSFETs
- 16-Pin PowerPAD™ Package
- Thermal Shutdown Protection
- Pre-Bias Compatible
- Power-Stage Shutdown Capability
- Programmable High-Side Sense Short-Circuit Protection

2 Applications

- Power Modules
- Networking/Telecom
- PCI Express
- Industrial
- Servers

3 Description

The TPS40077 is a mid-voltage, wide-input (4.5-V to 28-V), synchronous, step-down controller, offering design flexibility for a variety of user-programmable functions, including soft start, undervoltage lockout (UVLO), operating frequency, voltage feed-forward, and high-side, FET-sensed, short-circuit protection.

The TPS40077 drives external N-channel MOSFETs using second-generation, predictive-gate drive to minimize conduction in the body diode of the low-side FET and maximize efficiency. Pre-biased outputs are supported by not allowing the low-side FET to turn on until the voltage commanded by the closed-loop soft start is greater than the pre-bias voltage. Voltage feed-forward provides good response to input transients and provides a constant PWM gain over a wide input-voltage operating range to ease compensation requirements. Programmable short-circuit protection provides fault-current limiting and hiccup recovery to minimize power dissipation with a shorted output. The 16-pin PowerPAD package gives good thermal performance and a compact footprint.

Device Information⁽¹⁾

PART NUMBER	PACKAGE	BODY SIZE (NOM)
TPS40077	HTSSOP (16)	5.00 mm x 4.40 mm

(1) For all available packages, see the orderable addendum at the end of the data sheet.

Simplified Application Diagram

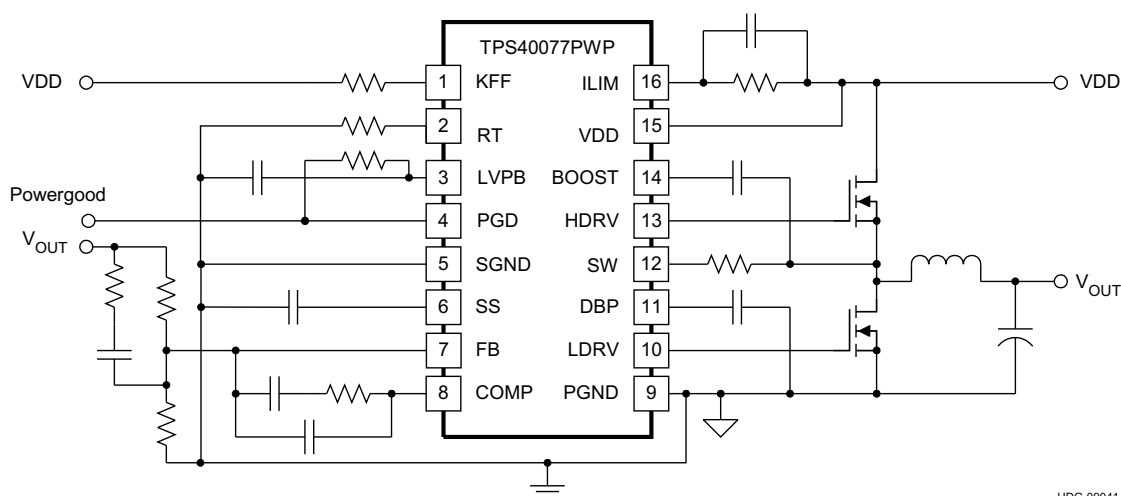

UDG-09041



Table of Contents

1 Features 1 2 Applications 1 3 Description 1 4 Revision History 2 5 Pin Configuration and Functions 3 6 Specifications 5 6.1 Absolute Maximum Ratings 5 6.2 ESD Ratings..... 5 6.3 Recommended Operating Conditions 5 6.4 Electrical Characteristics..... 6 6.5 Typical Characteristics 8 7 Detailed Description 12 7.1 Overview 12 7.2 Functional Block Diagram 12 7.3 Feature Description..... 13 7.4 Programming..... 17	8 Application and Implementation 21 8.1 Application Information..... 21 8.2 Typical Applications 21 8.3 Additional System Examples 32 9 Layout 34 9.1 Layout Guidelines 34 10 Device and Documentation Support 35 10.1 Device Support..... 35 10.2 Documentation Support 35 10.3 Receiving Notification of Documentation Updates 35 10.4 Community Resources..... 35 10.5 Trademarks 35 10.6 Electrostatic Discharge Caution..... 35 10.7 Glossary 35 11 Mechanical, Packaging, and Orderable Information 36
--	--

4 Revision History

NOTE: Page numbers for previous revisions may differ from page numbers in the current version.

Changes from Revision D (April 2009) to Revision E

Page

<ul style="list-style-type: none"> • Added <i>Feature Description</i> section, <i>Device Functional Modes</i>, <i>Application and Implementation</i> section, <i>Power Supply Recommendations</i> section, <i>Layout</i> section, <i>Device and Documentation Support</i> section, and <i>Mechanical, Packaging, and Orderable Information</i> section; editorial changes 1 • Deleted Ordering Information table 3 • Moved Package Dissipation Ratings table to <i>Power Dissipation</i> 16 	<p>1</p> <p>3</p> <p>16</p>
--	-----------------------------

5 Pin Configuration and Functions

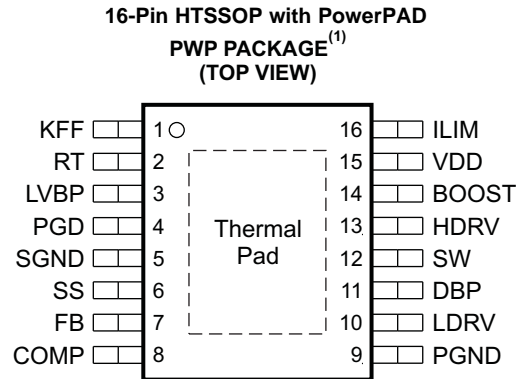

P0047-01

- (1) For more information on the PWP package, see the *PowerPAD Thermally Enhanced Package* technical brief (SLMA002).

Pin Functions

PIN		I/O	DESCRIPTION
NO.	NAME		
1	KFF	I	A resistor connected from this pin to VIN programs the amount of feed-forward voltage. The current fed into this pin is internally divided by 25 and used to control the slope of the PWM ramp and program UVLO. Nominal voltage at this pin is maintained at 400 mV.
2	RT	I	A resistor is connected from this pin to ground to set the internal oscillator and switching frequency.
3	LVBP	O	4.2-V reference used for internal device logic only. This pin should be bypassed by a 0.1- μ F ceramic capacitor. External loads that are less than 1 mA and electrically quiet may be applied.
4	PGD	O	This is an open-drain output that pulls to ground when soft start is active, or when the FB pin is outside a $\pm 10\%$ band around VREF.
5	SGND	—	Signal ground reference for the device. Low-level quiet circuitry around the IC should connect to this pin. This pin should be connected to the thermal pad under the IC, and that thermal pad should connect to the PGND pin. Do not allow power currents to flow in the thermal pad or in the SGND part of the ground for best results.
6	SS	I	Soft-start programming pin. A capacitor connected from this pin to GND programs the soft-start time. The capacitor is charged with an internal current source of 12 μ A. The resulting voltage ramp on the SS pin is used as a second noninverting input to the error amplifier. The voltage at this error amplifier input is approximately 1 V less than that on the SS pin. Output voltage regulation is controlled by the SS voltage ramp until the voltage on the SS pin reaches the internal offset voltage of 1 V plus the internal reference voltage of 700 mV. If SS is pulled below 225 mV, the device goes into a shutdown state where the power FETs are turned off and the prebias circuitry is reset. If the programmed UVLO voltage is below 6 V, connect a 330-k Ω resistor in parallel with the SS capacitor. Also provides timing for fault recovery attempts.
7	FB	I	Inverting input to the error amplifier. In normal operation, the voltage on this pin is equal to the internal reference voltage, 0.7 V.
8	COMP	O	Output of the error amplifier, input to the PWM comparator. A feedback network is connected from this pin to the FB pin to compensate the overall loop. The COMP pin is internally clamped to 3.4 V.
9	PGND	—	Power ground reference for the device. There should be a low-impedance path from this pin to the source(s) of the lower MOSFET(s).
10	LDRV	O	Gate drive for the N-channel synchronous rectifier. This pin switches from DBP (MOSFET on) to ground (MOSFET off). For proper operation, the total gate charge of the MOSFET connected to LDRV should be less than 50 nC.
11	DBP	O	8-V reference used for the gate drive of the N-channel synchronous rectifier. This pin should be bypassed to ground with a 1- μ F ceramic capacitor.
12	SW	I	This pin is connected to the switched node of the converter. It is used for short-circuit sensing and gate-drive timing information and is the return for the high-side driver. A 1.5- Ω resistor is required in series with this pin for protection against substrate current issues.
13	HDRV	O	Floating gate drive for the high-side N-channel MOSFET. This pin switches from BOOST (MOSFET on) to SW (MOSFET off).

Pin Functions (continued)

PIN		I/O	DESCRIPTION
NO.	NAME		
14	BOOST	I	The peak voltage on BOOST is equal to the SW node voltage plus the voltage present at DBP less the bootstrap diode drop. This drop can be 1.4 V for the internal bootstrap diode or 300 mV for an external Schottky diode. The voltage differential between this pin and SW is the available drive voltage for the high-side FET.
15	VDD	I	Supply voltage for the device.
16	ILIM	I	Short-circuit-protection programming pin. This pin is used to set the short circuit detection threshold. An internal current sink from this pin to ground sets a voltage drop across an external resistor connected from this pin to VDD. The voltage on this pin is compared to the voltage drop ($V_{VDD} - V_{SW}$) across the high side N-channel MOSFET during conduction. Just prior to the beginning of a switching cycle, this pin is pulled to approximately $V_{DD}/2$ and released when SW is within 2 V of V_{DD} or after a timeout (the precondition time), whichever occurs first. Placing a capacitor across the resistor from ILIM to VDD allows the ILIM threshold to decrease during the switch-on time, effectively programming the ILIM blanking time. See <i>Application Information</i> .

6 Specifications

6.1 Absolute Maximum Ratings

over operating free-air temperature range (unless otherwise noted)⁽¹⁾

		MIN	MAX	UNIT
Input voltage, V_{DD}	VDD, ILIM		30	V
	COMP, FB, KFF, PGD, LVBP	-0.3	6	
	SW	-0.3	40	
	SW, transient (<50 ns)		-2.5	
Output voltage, V_{OUT}	COMP, KFF, RT, SS	-0.3	6	V
	VBOOST		50	
	DBP		10.5	
	LVBP		6	
Output current source, I_{OUT} (LDRV, HDRV)			1.5	A
Output current sink, I_{OUT}	LDRV, HDRV		2	A
	KFF		10	
Output current	RT		1	mA
	LVBP		1.5	
Lead temperature, 1.6 mm (1/16 inch) from case (10 s)			260	°C
Operating junction temperature, T_J		-40	125	°C
Storage temperature, T_{stg}		-55	150	°C

(1) Stresses beyond those listed under *Absolute Maximum Ratings* may cause permanent damage to the device. These are stress ratings only, which do not imply functional operation of the device at these or any other conditions beyond those indicated under *Recommended Operating Conditions*. Exposure to absolute-maximum-rated conditions for extended periods may affect device reliability.

6.2 ESD Ratings

		VALUE	UNIT
$V_{(ESD)}$ Electrostatic discharge	Human-body model (HBM), per ANSI/ESDA/JEDEC JS-001 ⁽¹⁾	±2000	V
	Charged-device model (CDM), per JEDEC specification JESD22-C101 ⁽²⁾	±1500	

(1) JEDEC document JEP155 states that 500-V HBM allows safe manufacturing with a standard ESD control process.

(2) JEDEC document JEP157 states that 250-V CDM allows safe manufacturing with a standard ESD control process.

6.3 Recommended Operating Conditions

over operating free-air temperature range (unless otherwise noted)

		MIN	NOM	MAX	UNIT
V_{DD}	Input voltage	4.5		28	V
T_A	Operating free-air temperature	-40		85	°C

6.4 Electrical Characteristics

$T_A = -40^{\circ}\text{C}$ to 85°C , $V_{IN} = 12\text{ V}_{\text{dc}}$, $R_T = 90.9\text{ k}\Omega$, $I_{\text{KFF}} = 300\text{ }\mu\text{A}$, $f_{\text{SW}} = 500\text{ kHz}$, and all parameters at zero power dissipation (unless otherwise noted).

PARAMETER		TEST CONDITIONS	MIN	TYP	MAX	UNIT
V_{VDD}	Input voltage range, V_{IN}		4.5		28	V
I_{VDD}	Quiescent current	Output drivers not switching		2.5	3.5	mA
V_{LVBP}	Output voltage	$T_A = T_J = 25^{\circ}\text{C}$	3.9	4.2	4.5	V
OSCILLATOR/RAMP GENERATOR						
f_{OSC}	Accuracy		450	500	550	kHz
V_{RAMP}	PWM ramp voltage ⁽¹⁾	$V_{\text{PEAK}} - V_{\text{VAL}}$		2		V
V_{RT}	RT voltage		2.23	2.4	2.58	V
t_{ON}	Minimum output pulse time ⁽¹⁾	$C_{\text{HDRV}} = 0\text{ nF}$			150	ns
	Maximum duty cycle	$V_{\text{FB}} = 0\text{ V}$, $100\text{ kHz} \leq f_{\text{SW}} \leq 500\text{ kHz}$	84%		93%	
		$V_{\text{FB}} = 0\text{ V}$, $f_{\text{SW}} = 1\text{ MHz}$	76%		93%	
V_{KFF}	Feed-forward voltage		0.35	0.4	0.45	V
I_{KFF}	Feed-forward current operating range ⁽¹⁾		20		1100	μA
SOFT START						
I_{SS}	Charge current		7	12	17	μA
t_{DSCH}	Discharge time	$C_{\text{SS}} = 3.9\text{ nF}$	25		75	μs
t_{SS}	Soft-start time	$C_{\text{SS}} = 3.9\text{ nF}$, V_{SS} rising from 0.7 V to 1.6 V	210	290	500	μs
V_{SSSD}	Turnon threshold		310	365	420	mV
	Shutdown threshold		225	275	325	
V_{SSSDH}	Shutdown threshold hysteresis		35		150	mV
V_{DBP}	Output voltage	$V_{\text{DD}} > 10\text{ V}$	7	8	9	V
		$V_{\text{DD}} = 4.5\text{ V}$, $I_{\text{OUT}} = 25\text{ mA}$	4	4.3		
ERROR AMPLIFIER						
V_{FB}	Feedback regulation voltage total variation	$T_J = 25^{\circ}\text{C}$	0.698	0.7	0.704	V
		$0^{\circ}\text{C} \leq T_J \leq 85^{\circ}\text{C}$	0.69	0.7	0.707	
		$-40^{\circ}\text{C} \leq T_J \leq 85^{\circ}\text{C}$	0.69	0.7	0.715	
V_{SS}	Soft-start offset from V_{SS} ⁽¹⁾	Offset from V_{SS} to error amplifier		1		V
G_{BW}	Gain bandwidth ⁽¹⁾		5	10		MHz
A_{VOL}	Open-loop gain		50			dB
I_{SRC}	Output source current		2.5	4.5		mA
I_{SINK}	Output sink current		2.5	6		mA
I_{BIAS}	Input bias current	$V_{\text{FB}} = 0.7\text{ V}$	-250		0	nA
SHORT-CIRCUIT CURRENT PROTECTION						
I_{ILIM}	Current sink into current limit		80	105	125	μA
$V_{\text{ILIM(orst)}}$	Current limit offset voltage ($V_{\text{SW}} - V_{\text{ILIM}}$)	$V_{\text{ILIM}} = 11.5\text{ V}$, $V_{\text{VDD}} = 12\text{ V}$	-75	-50	-30	mV
t_{HSC}	Minimum HDRV pulse duration	During short circuit		135	225	ns
	Propagation delay to output ⁽¹⁾			50		ns
t_{BLANK}	Blanking time ⁽¹⁾			50		ns
t_{OFF}	Off time during a fault (SS cycle times)			7		Cycles
V_{SW}	Switching level to end precondition ($V_{\text{VDD}} - V_{\text{SW}}$) ⁽¹⁾			2		V
t_{PC}	Precondition time ⁽¹⁾				100	ns
V_{ILIM}	Current limit precondition voltage threshold ⁽¹⁾			6.8		V

(1) Ensured by design. Not production tested.

Electrical Characteristics (continued)

$T_A = -40^\circ\text{C}$ to 85°C , $V_{IN} = 12\text{ V}_{dc}$, $R_T = 90.9\text{ k}\Omega$, $I_{KFF} = 300\text{ }\mu\text{A}$, $f_{SW} = 500\text{ kHz}$, and all parameters at zero power dissipation (unless otherwise noted).

PARAMETER		TEST CONDITIONS	MIN	TYP	MAX	UNIT
OUTPUT DRIVERS						
t_{HFALL}	High-side driver fall time (HDRV – SW) ⁽¹⁾	$C_{HDRV} = 2200\text{ pF}$		36		ns
t_{HRISE}	High-side driver rise time (HDRV – SW) ⁽¹⁾			48		ns
t_{HFALL}	High-side driver fall time (HDRV – SW) ⁽¹⁾	$C_{HDRV} = 2200\text{ pF}$, $V_{VDD} = 4.5\text{ V}$, $0.2\text{ V} \leq V_{SS} \leq 4\text{ V}$		72		ns
t_{HRISE}	High-side driver rise time (HDRV – SW) ⁽¹⁾			96		ns
t_{LFALL}	Low-side driver fall time ⁽¹⁾	$C_{LDRV} = 2200\text{ pF}$		24		ns
t_{LRISE}	Low-side driver rise time ⁽¹⁾			48		ns
t_{LFALL}	Low-side driver fall time ⁽¹⁾	$C_{LDRV} = 2200\text{ pF}$, $V_{VDD} = 4.5\text{ V}$, $0.2\text{ V} \leq V_{SS} \leq 4\text{ V}$		48		ns
t_{LRISE}	Low-side driver rise time ⁽¹⁾			96		ns
V_{OH}	High-level output voltage, HDRV ($V_{BOOST} - V_{HDRV}$)	$I_{HDRV} = -0.01\text{ A}$		0.7	1	V
		$I_{HDRV} = -0.1\text{ A}$		0.95	1.3	
V_{OL}	Low-level output voltage, HDRV ($V_{HDRV} - V_{SW}$)	$I_{HDRV} = 0.01\text{ A}$		0.06	0.1	V
		$I_{HDRV} = 0.1\text{ A}$		0.65	1	
V_{OH}	High-level output voltage, LDRV ($V_{DBP} - V_{LDRV}$)	$I_{LDRV} = -0.01\text{ A}$		0.65	1	V
		$I_{LDRV} = -0.1\text{ A}$		0.875	1.2	
V_{OL}	Low-level output voltage, LDRV	$I_{LDRV} = 0.01\text{ A}$		0.03	0.05	V
		$I_{LDRV} = 0.1\text{ A}$		0.3	0.5	
V_{BOOST}	Output voltage	$V_{DD} = 12\text{ V}$	15.2	17		V
UVLO						
V_{UVLO}	Programmable UVLO threshold voltage	$R_{KFF} = 90.9\text{ k}\Omega$, turn-on, V_{VDD} rising	6.2	7.2	8.2	V
	Programmable UVLO hysteresis	$R_{KFF} = 90.9\text{ k}\Omega$	1.1	1.55	2	V
	Fixed UVLO threshold voltage	Turn-on, V_{VDD} rising	4.15	4.3	4.45	V
	Fixed UVLO hysteresis		275	365		mV
POWER GOOD						
V_{PG}	Power-good voltage	$I_{PG} = 1\text{ mA}$		370	500	mV
V_{OH}	High-level output voltage, FB			770		mV
V_{OL}	Low-level output voltage, FB			630		mV
THERMAL SHUTDOWN						
	Shutdown temperature threshold ⁽¹⁾			165		$^\circ\text{C}$
	Hysteresis ⁽¹⁾			15		$^\circ\text{C}$

6.5 Typical Characteristics

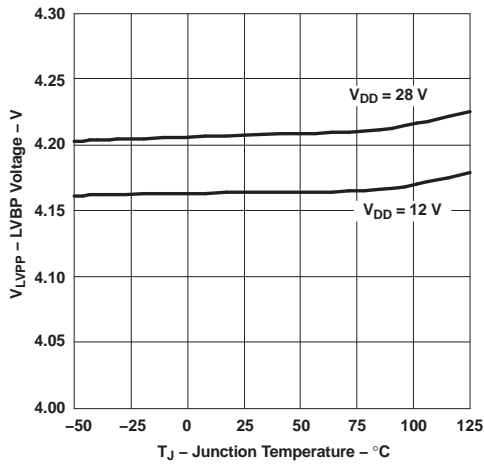

Figure 1. LVP Voltage vs Junction Temperature

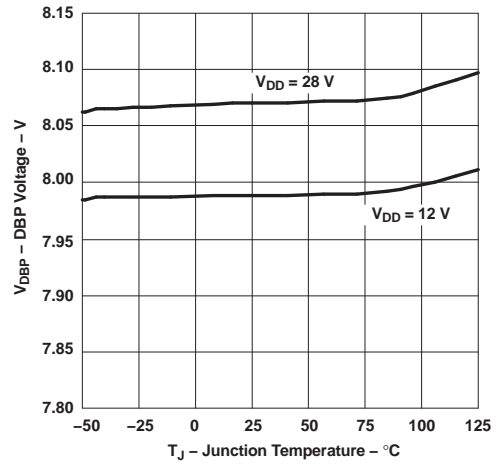

Figure 2. DBP Voltage vs Junction Temperature

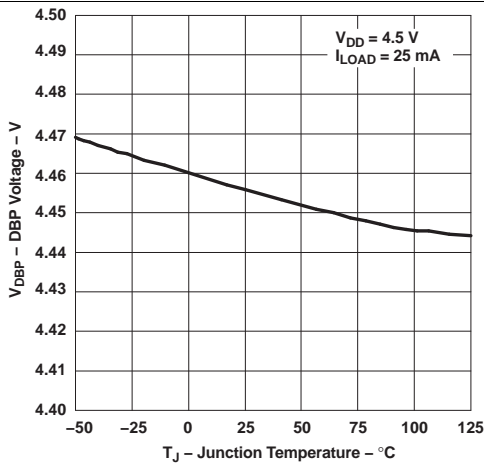

Figure 3. DBP Voltage vs Junction Temperature

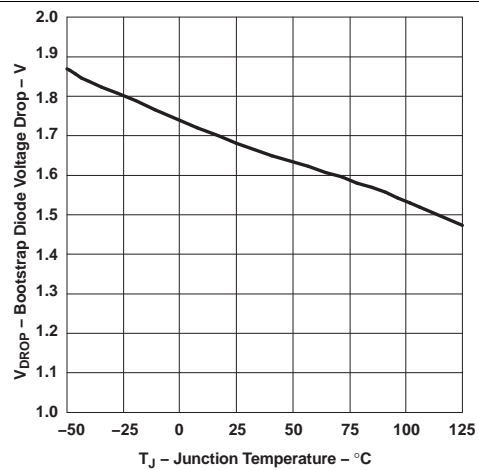

Figure 4. Bootstrap Diode Voltage vs Junction Temperature

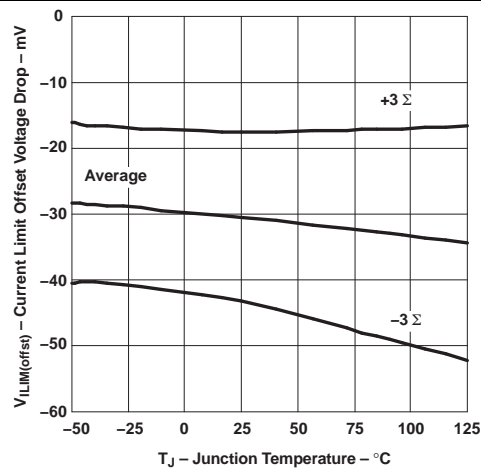

Figure 5. Current Limit Offset Voltage vs Junction Temperature

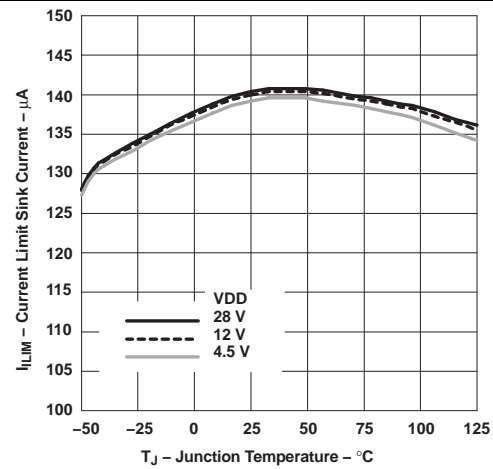

Figure 6. Current Limit Sink Current vs Junction Temperature

Typical Characteristics (continued)

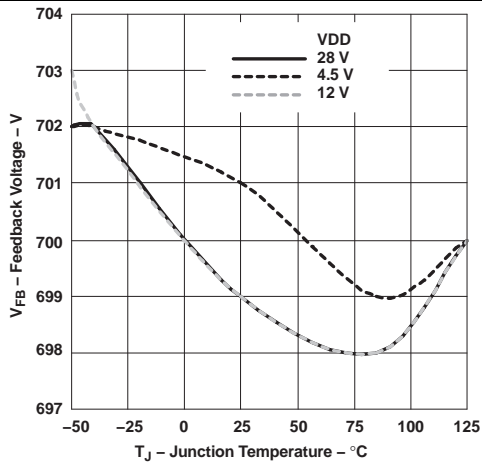

Figure 7. Feedback Regulation Voltage vs Junction Temperature

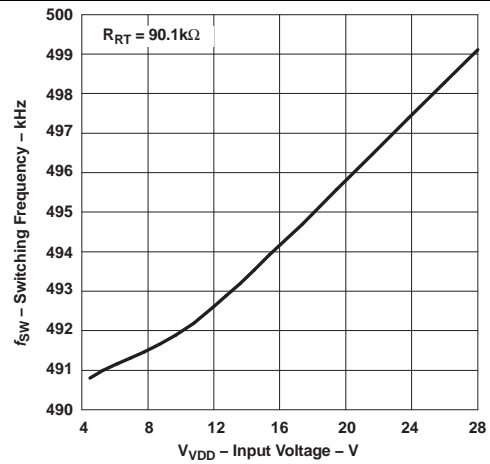

Figure 8. Switching Frequency vs Input Voltage

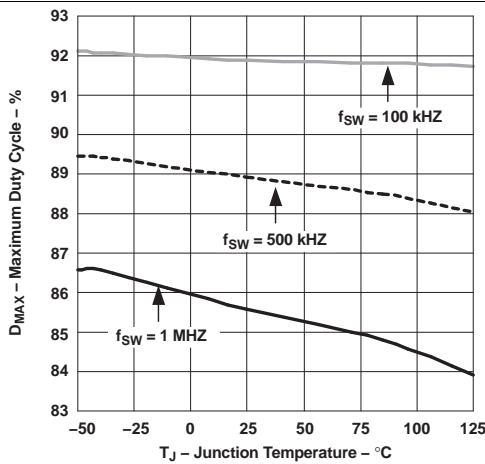

Figure 9. Maximum Duty Cycle vs Junction Temperature

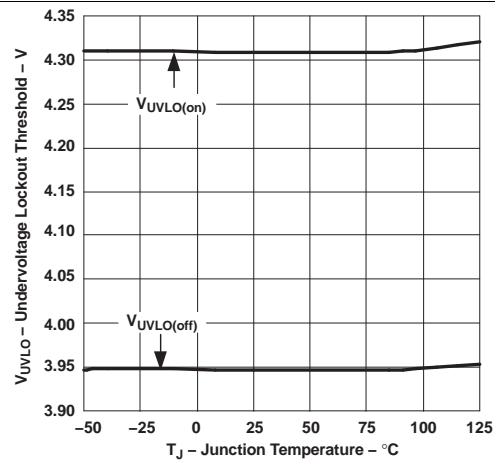

Figure 10. Undervoltage Lockout vs Junction Temperature

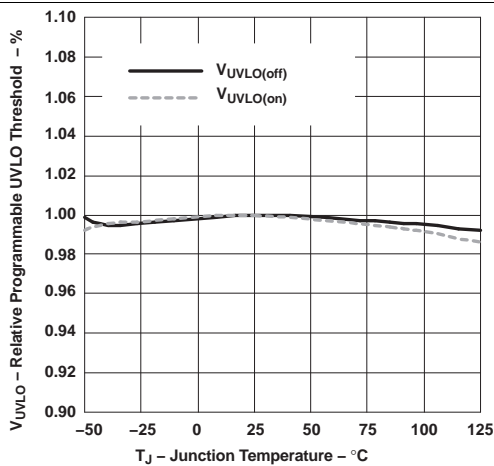

Figure 11. Programmable UVLO Threshold vs Junction Temperature

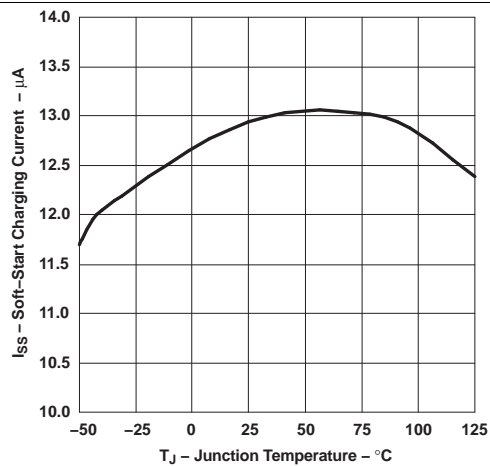

Figure 12. Soft-Start Charging Current vs Junction Temperature

Typical Characteristics (continued)

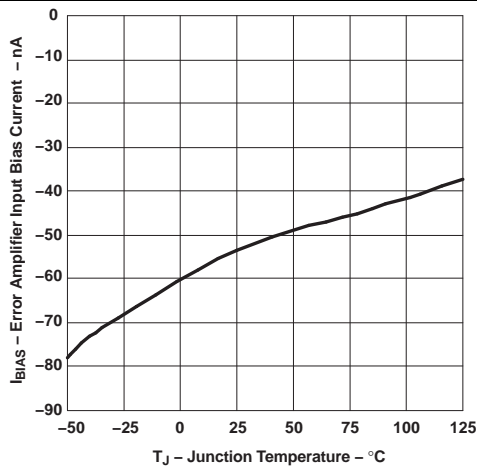

Figure 13. Error Amplifier Input Bias Current vs Junction Temperature

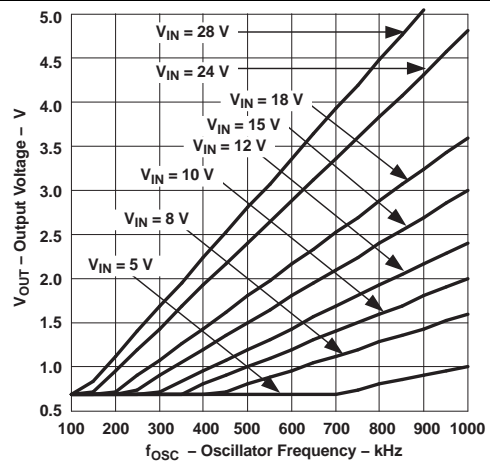

Figure 14. Minimum Output Voltage vs Frequency

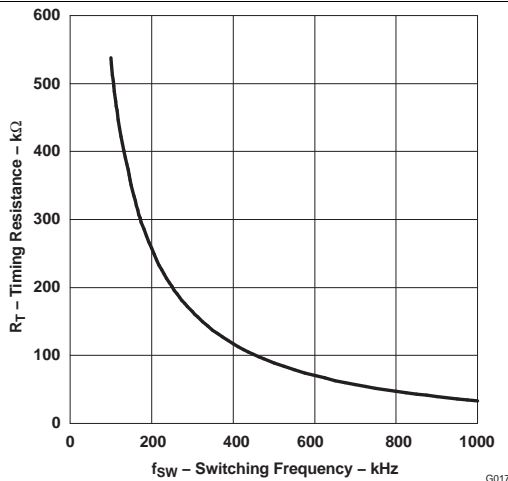

Figure 15. Switching Frequency vs Timing Resistance

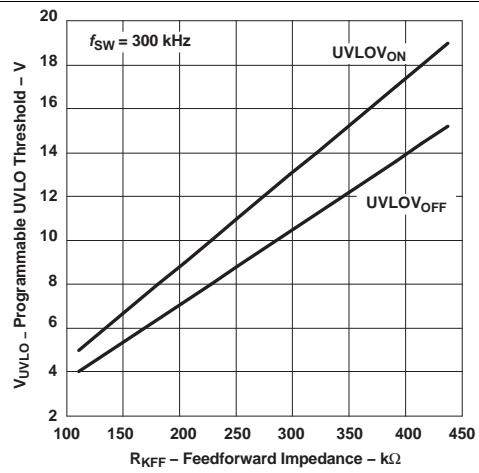

Figure 16. Undervoltage Lockout Threshold vs Feed-Forward Impedance

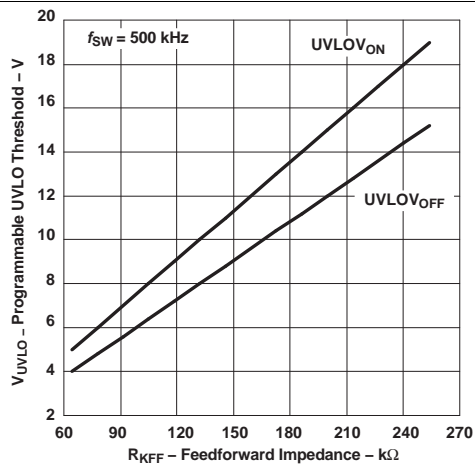

Figure 17. Undervoltage Lockout Threshold vs Feed-Forward Impedance

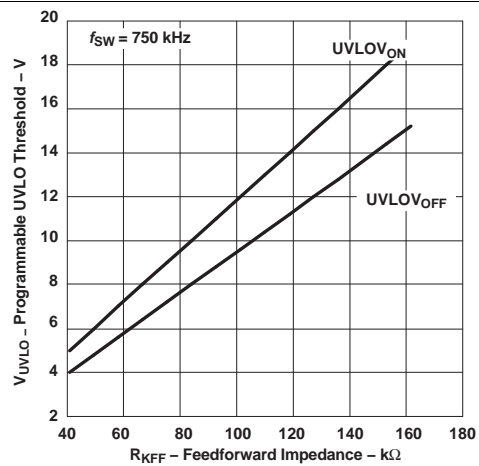

Figure 18. Undervoltage Lockout Threshold vs Feed-Forward Impedance

Typical Characteristics (continued)

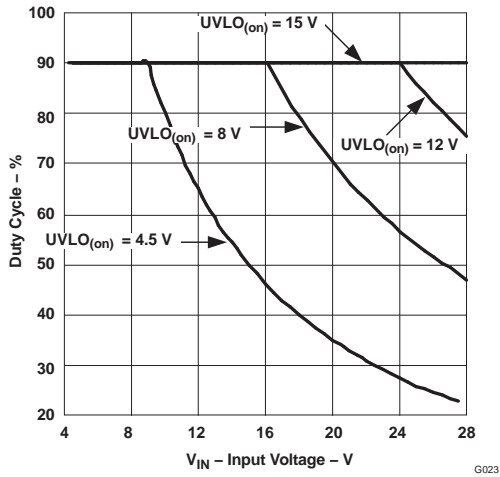

Figure 19. Typical Maximum Duty Cycle vs Input Voltage

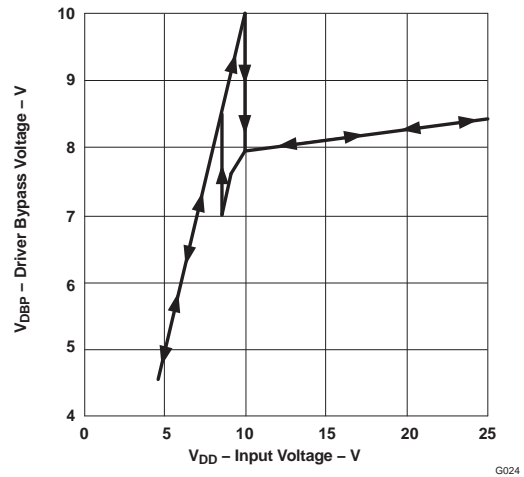

Figure 20. DBP Voltage vs Input Voltage

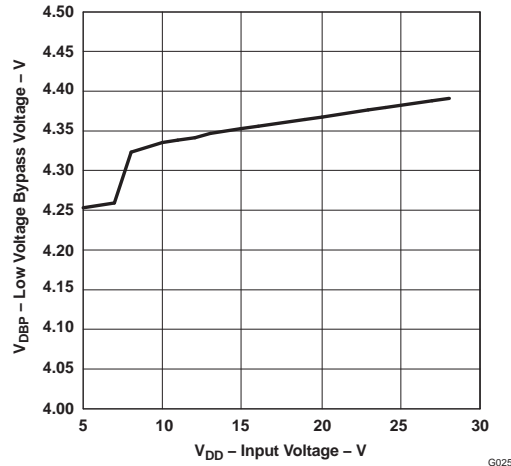

Figure 21. Input Voltage vs Low-Voltage Bypass Voltage

7 Detailed Description

7.1 Overview

The TPS40077 allows the user to construct synchronous voltage-mode buck converters with inputs ranging from 4.5 V to 28 V and outputs as low as 700 mV. Predictive Gate Drive circuitry optimizes switching delays for increased efficiency and improved converter output-power capability. Voltage feed forward is employed to ease loop compensation for wide-input-range designs and provide better line transient response.

The TPS40077 incorporates circuitry to allow start-up into a preexisting output voltage without sinking current from the source of the preexisting output voltage. This avoids damaging sensitive loads at start-up. An integrated power-good indicator is available for logic (open-drain) output of the condition of the output of the converter.

7.2 Functional Block Diagram

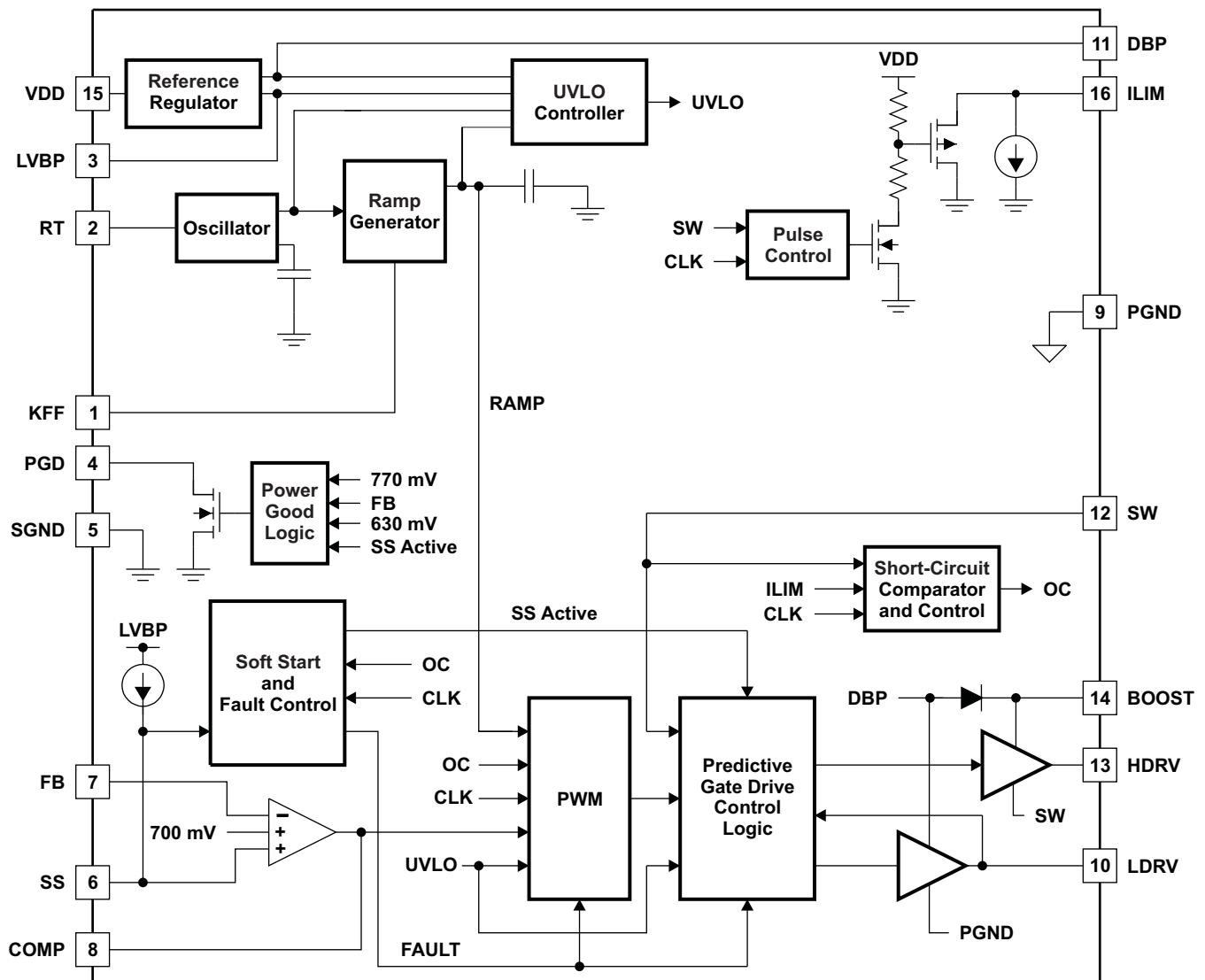

B0150-01

Feature Description (continued)

7.3.3 Setting The Switching Frequency (Programming The Clock Oscillator)

The TPS40077 has independent clock oscillator and PWM ramp generator circuits. The clock oscillator serves as the master clock to the ramp generator circuit. Connecting a single resistor from RT to ground sets the switching frequency of the clock oscillator. The clock frequency is related to R_T with [Equation 3](#).

$$R_T = \left(\frac{1}{f_{SW}(\text{kHz}) \times 17.82 \times 10^{-6}} - 23 \right) \text{ k}\Omega \quad (3)$$

7.3.4 Loop Compensation

Voltage-mode, buck-type converters are typically compensated using Type III networks. Because the TPS40077 uses voltage feed-forward control, the gain of the voltage feed-forward circuit must be included in the PWM gain. The gain of the voltage feed-forward circuit, combined with the PWM circuit and power stage for the TPS40077 is [Equation 4](#).

$$K_{PWM} \cong V_{UVLO(on)} \quad (4)$$

The remainder of the loop compensation is performed as in a normal buck converter. Note that the voltage feed-forward circuitry removes the input voltage term from the expression for PWM gain. PWM gain is strictly a function of the programmed start-up voltage.

7.3.5 Shutdown and Sequencing

The TPS40077 can be shut down by pulling the SS pin below 250 mV. In this state, both of the output drivers are in the low-output state, turning off both of the power FETs. This places the output of the converter in a high-impedance state. When shutting down the converter, a crisp pulldown of the SS pin is preferred to a slow pulldown. A slow pulldown could allow the output to be pulled low, possibly sinking current from the load. As a general rule of thumb, the fall time of SS when shutting down the converter should be no more than 1/10th of the control loop crossover frequency. An example of a shutdown interface is shown in [Figure 23](#).

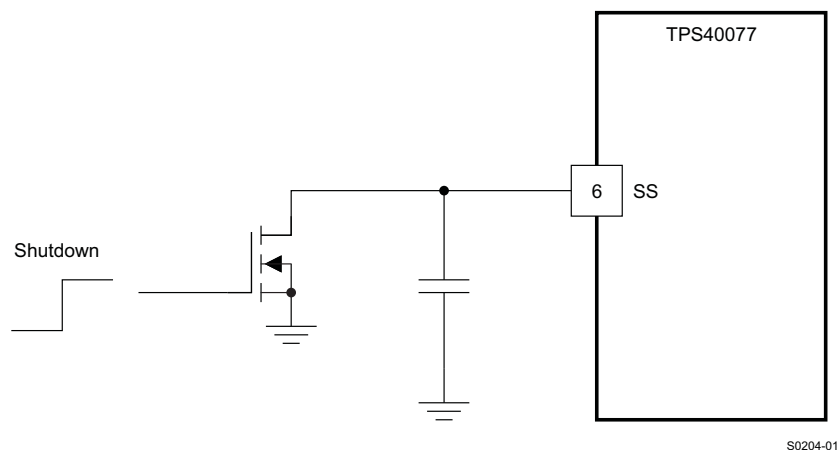
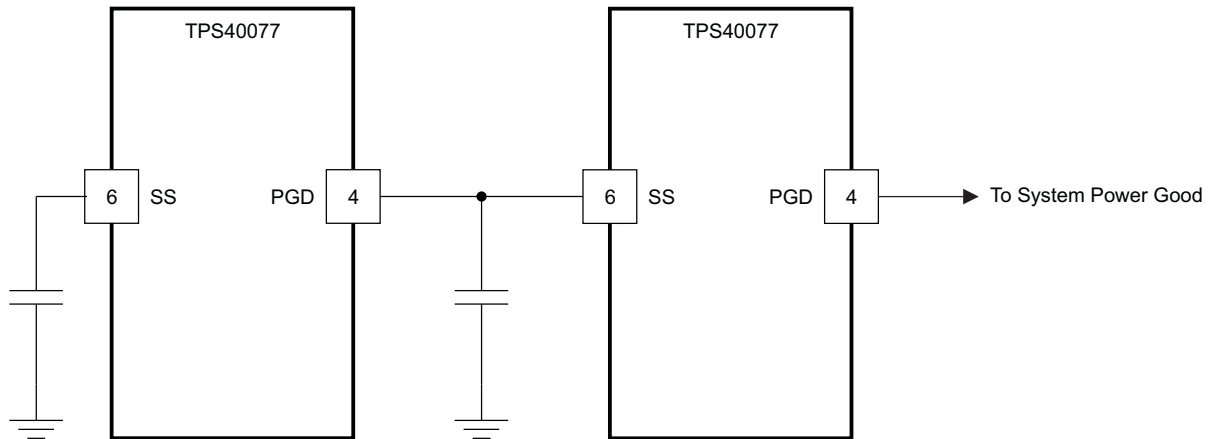

Figure 23. TPS40077 Shutdown

In a similar manner, power supplies based on the TPS40077 can be sequenced by connecting the PGD pin of the first supply to come up to the SS pin of the second supply as shown in [Figure 24](#).

Feature Description (continued)



S0205-01

Figure 24. TPS40077 Sequencing

7.3.6 Boost and LVBP Bypass Capacitance

The BOOST capacitance provides a local, low-impedance flying source for the high-side driver. The BOOST capacitor should be a good-quality, high-frequency capacitor. A capacitor with a minimum value of 100-nF is suggested.

The LVBP pin must provide energy for both the synchronous MOSFET and the high-side MOSFET (via the BOOST capacitor). The suggested value for this capacitor is 1- μ F ceramic, minimum.

7.3.7 Internal Regulators

The internal regulators are linear regulators that provide controlled voltages from which the drivers and the internal circuitry operate. The DBP pin is connected to a nominal 8-V regulator that provides power for the driver circuits. This regulator has two modes of operation. At V_{DD} voltages below 8.5 V, the regulator is in a low-dropout mode of operation and tries to provide as little impedance as possible from V_{DD} to DBP. Above 10 V at V_{DD} , the regulator regulates DBP to 8 V. Between these two voltages, the regulator remains in the state it was in when V_{DD} entered this region (see Figure 20). Small amounts of current can be drawn from this pin for other circuit functions, as long as power dissipation in the controller device remains at acceptable levels and junction temperature does not exceed 125°C.

The LVBP pin is connected to another internal regulator that provides 4.2 V (nom) for the operation of low-voltage circuitry in the controller. This pin can be used for other circuit purposes, but extreme care must be taken to ensure that no extra noise is coupled onto this pin; otherwise, controller performance suffers. Current draw is not to exceed 1 mA. See Figure 21 for typical output voltage at this pin.

7.3.8 Power Dissipation

The power dissipation in the TPS40077 is largely dependent on the MOSFET driver currents and the input voltage. The driver current is proportional to the total gate charge, Q_g , of the external MOSFETs. Driver power (neglecting external gate resistance) can be calculated with Equation 5.

$$P_D = Q_g \times V_{DR} \times f_{SW} \quad (\text{Watts/driver})$$

where

$$V_{DR} \text{ is the driver output voltage} \quad (5)$$

The total power dissipation in the TPS40077, assuming the same MOSFET is selected for both the high-side and synchronous rectifier, is described in Equation 6 or Equation 7.

$$P_T = \left(\frac{2 \times P_D}{V_{DR}} + I_Q \right) \times V_{IN} \quad (\text{Watts}) \quad (6)$$

Feature Description (continued)

or

$$P_T = (2 \times Q_g \times f_{SW} + I_Q) \times V_{IN} \quad (\text{Watts})$$

where I_Q is the quiescent operating current (neglecting drivers) (7)

The maximum power capability of the TPS40077 PowerPAD package is dependent on the layout as well as air flow. The thermal impedance from junction to air, assuming 2-oz. copper trace and thermal pad with solder and no air flow, is 37°C/W. See the application report titled *PowerPAD Thermally Enhanced Package (SLMA002)* for detailed information on PowerPAD package mounting and usage.

The maximum allowable package power dissipation is related to ambient temperature by [Equation 8](#). For θ_{JA} , see [Table 1](#).

$$P_T = \frac{T_J - T_A}{\theta_{JA}} \quad (\text{Watts}) \quad (8)$$

Table 1. Package Dissipation Ratings

	THERMAL IMPEDANCE, JUNCTION-TO-AMBIENT ⁽¹⁾	T _A = 25°C POWER RATING	T _A = 85°C POWER RATING
Natural convection	37°C/W	2.7 W	1.08 W
150 LFM airflow	30°C/W	3.33 W	1.33 W
250 LFM airflow	28°C/W	3.57 W	1.42 W
500 LFM airflow	26°C/W	3.84 W	1.52 W

(1) For more information on the board and the methods used to determine ratings, see the *PowerPAD Thermally Enhanced Package* application report ([SLMA002](#)).

Substituting [Equation 8](#) into [Equation 7](#) and solving for f_{SW} yields the maximum operating frequency for the TPS40077. The result is described in [Equation 9](#).

$$f_{SW} = \frac{\left(\left[\frac{(T_J - T_A)}{(\theta_{JA} \times V_{DD})} \right] - I_Q \right)}{(2 \times Q_g)} \quad (\text{Hz}) \quad (9)$$

7.3.9 Boost Diode

The TPS40077 series has internal diodes to charge the boost capacitor connected from SW to BOOST. The drop across these diodes is rather large, 1.4 V nominal, at room temperature. If this drop is too large for a particular application, an external diode may be connected from DBP (anode) to BOOST (cathode). This provides significantly improved gate drive for the high-side FET, especially at lower input voltages.

7.3.10 Synchronous Rectifier Control

[Table 2](#) describes the state of the rectifier MOSFET control under various operating conditions.

Table 2. Synchronous Rectifier MOSFET States

SYNCHRONOUS RECTIFIER OPERATION DURING			
SOFT-START	NORMAL	FAULT (FAULT RECOVERY IS SAME AS SOFT-START)	OVERVOLTAGE
Off until first high-side pulse is detected, then on when high-side MOSFET is off	Turns off at the start of a new cycle. Turns on when the high-side MOSFET is turned off	OFF	Turns OFF only at start of next cycle only if the pulse width modulator duty cycle is greater than zero. Otherwise, stays ON

For proper operation, the total gate charge of the MOSFET connected to LDRV must be less than 50 nC.

7.4 Programming

7.4.1 Programming The Ramp Generator Circuit and UVLO

The ramp generator circuit provides the actual ramp used by the PWM comparator. The ramp generator provides voltage feed-forward control by varying the PWM ramp slope with line voltage, while maintaining a constant ramp magnitude. Varying the PWM ramp directly with line voltage provides excellent response to line variations, because the PWM is not required to wait for loop delays before changing the duty cycle. (See [Figure 25](#)).

The PWM ramp must reach approximately 1 V in amplitude during a clock cycle, or the PWM is not allowed to start. The PWM ramp time is programmed via a single resistor (R_{KFF}) connected from KFF VDD. R_{KFF} , V_{START} , and R_T are related by (approximately) [Equation 10](#).

$$R_{KFF} = 0.131 \times R_T \times V_{UVLO(on)} - 1.61 \times 10^{-3} \times V_{UVLO(on)}^2 + 1.886 \times V_{UVLO} - 1.363 - 0.02 \times R_T - 4.87 \times 10^{-5} \times R_T^2$$

where

- R_T and R_{KFF} are in $k\Omega$
 - $V_{UVLO(on)}$ is in V
- (10)

This yields typical numbers for the programmed start-up voltage. The minimum and maximum values may vary up to $\pm 15\%$ from this number. [Figure 16](#) through [Figure 18](#) show the typical relationship of $V_{UVLO(on)}$, $V_{UVLO(off)}$ and R_{KFF} at three common frequencies.

The programmable UVLO circuit incorporates 20% hysteresis from the start voltage to the shutdown voltage. For example, if the start-up voltage is programmed to be 10 V, the controller starts when V_{DD} reaches 10 V and shuts down when V_{DD} falls below 8 V. The maximum duty cycle begins to decrease as the input voltage rises to twice the start-up voltage. Below this point, the maximum duty cycle is as specified in the [Electrical Characteristics](#). Note that with this scheme, the theoretical maximum output voltage that the converter can produce is approximately two times the programmed start-up voltage. For design, set the programmed start-up voltage equal to or greater than the desired output voltage divided by maximum duty cycle (85% for frequencies 500 kHz and below). For example, a 5-V output converter should not have a programmed start-up voltage below 5.9 V. [Figure 25](#) shows the theoretical maximum duty cycle (typical) for various programmed start-up voltages.

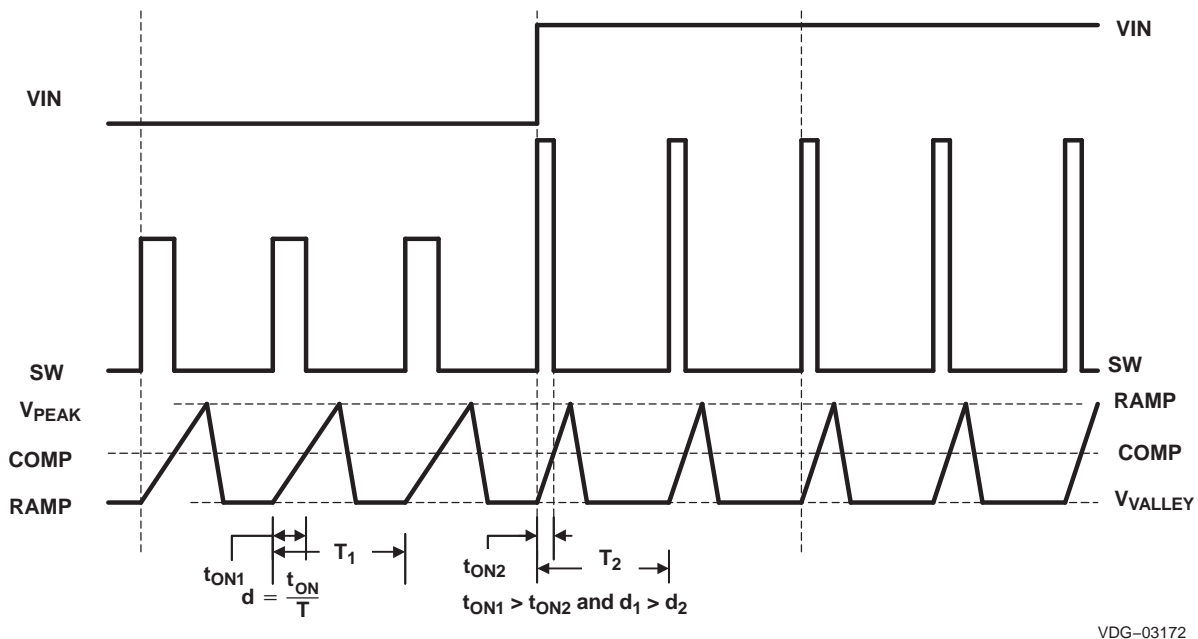

Figure 25. Voltage Feed-Forward and PWM Duty Cycle Waveforms

Programming (continued)

7.4.2 Programming Soft Start

TPS40077 uses a closed-loop approach to ensure a controlled ramp on the output during start-up. Soft start is programmed by connecting an external capacitor (C_{SS}) from the SS pin to GND. This capacitor is charged by a fixed current, generating a ramp signal. The voltage on SS is level-shifted down approximately 1 V and fed into a separate noninverting input to the error amplifier. The loop is closed on the lower of the level-shifted SS voltage or the 700-mV internal reference voltage. Once the level-shifted SS voltage rises above the internal reference voltage, output-voltage regulation is based on the internal reference. To ensure a controlled ramp-up of the output voltage, the soft-start time should be greater than the $L-C_{OUT}$ time constant or [Equation 11](#).

$$t_{START} \geq 2\pi \times \sqrt{L \times C_{OUT}} \quad (11)$$

Note that there is a direct correlation between t_{START} and the input current required during start-up. The lower t_{START} is, the higher the input current required during start-up, because the output capacitance must be charged faster. For a desired soft-start time, the soft-start capacitance, C_{SS} , can be found from [Equation 12](#).

$$C_{SS} = t_{SS} \times \frac{I_{SS}}{V_{FB}} \quad (12)$$

7.4.3 Programming Short-Circuit Protection

The TPS40077 uses a two-tier approach for short-circuit protection. The first tier is a pulse-by-pulse protection scheme. Short-circuit protection is implemented on the high-side MOSFET by sensing the voltage drop across the MOSFET when its gate is driven high. The MOSFET voltage is compared to the voltage dropped across a resistor (R_{ILIM}) connected from V_{DD} to the ILIM pin when driven by a constant-current sink. If the voltage drop across the MOSFET exceeds the voltage drop across the ILIM resistor, the switching pulse is immediately terminated. The MOSFET remains off until the next switching cycle is initiated. This is illustrated in [Figure 26](#).

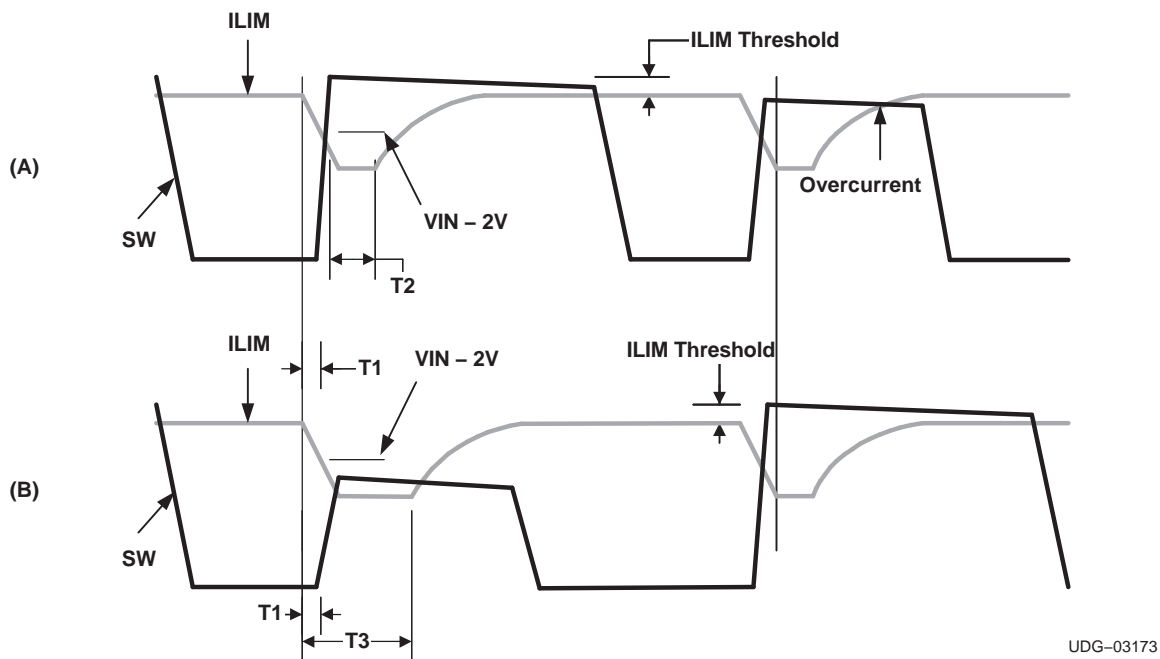

Figure 26. Switching and Current-Limit Waveforms and Timing Relationship

Programming (continued)

In addition, just prior to the high-side MOSFET turning on, the ILIM pin is pulled down to approximately half of V_{VDD} . The ILIM pin is allowed to return to its nominal value after one of two events occurs. If the SW node rises to within approximately 2 V of V_{VDD} , the device allows ILIM to go back to its nominal value. This is illustrated in [Figure 26\(A\)](#). T1 is the delay time from the internal PWM signal being asserted and the rise of SW. This includes a driver delay of 50 ns, typical. T2 is the reaction time of the sensing circuit that allows ILIM to start to return to its nominal value, typically 20 ns. The second event that can cause ILIM to return to its nominal value is for an internal timeout to expire. This is illustrated in [Figure 26\(B\)](#) as T3. Here SW never rises to $V_{VDD} - 2$ V, for whatever reason, and the internal timer times out, releasing the ILIM pin.

Prior to ILIM starting back to its nominal value, overcurrent sensing is not enabled. In normal operation, this ensures that the SW node is at a higher voltage than ILIM when overcurrent sensing starts, avoiding false trips while allowing for a quicker blanking delay than would ordinarily be possible. Placing a capacitor across R_{ILIM} sets an exponential approach to the normal voltage at the ILIM pin. This exponential decay of the overcurrent threshold can be used to compensate for ringing on the SW node after its rising edge and to help compensate for slower-turnon FETs. Choosing the proper capacitance requires care. If the capacitance is too large, the voltage at ILIM does not approach the desired overcurrent level quickly enough, resulting in an apparent shift in overcurrent threshold as pulse duration changes. As a general rule, it is best to make the time constant of the R-C at the ILIM pin 0.2 times or less of the nominal pulse duration of the converter as shown in [Equation 17](#).

Also, the comparator that uses ILIM and SW to determine if an overcurrent condition exists has a clamp on its SW input. This clamp makes the SW node never appear to fall more than 1.4 V (approximately, could be as much as 2 V at -40°C) below V_{VDD} . When ILIM is more than 1.4 V below V_{VDD} , the overcurrent circuit is effectively disabled.

The second-tier protection incorporates a fault counter. The fault counter is incremented on each cycle with an overcurrent pulse and decremented on a clock cycle without an overcurrent pulse. When the counter reaches seven (7), a fault condition is declared by the controller. When this happens, the outputs are placed in a state defined in [Table 2](#). Seven soft-start cycles are initiated (without activity on the HDRV and LDRV outputs) and the PWM is disabled during this period. The counter is decremented on each soft-start cycle. When the counter is decremented to zero, the PWM is re-enabled and the controller attempts to restart. If the fault has been removed, the output starts up normally. If the output is still present, the counter counts seven overcurrent pulses and re-enters the second-tier fault mode. Refer to [Figure 27](#) for typical fault-protection waveforms.

In [Equation 13](#), the minimum short-circuit limit setpoint ($I_{SCP(\min)}$) depends on t_{START} , C_{OUT} , V_{OUT} , ripple current in the inductor (I_{RIPPLE}), and the load current at turnon (I_{LOAD}).

$$I_{SCP(\min)} > \left(\frac{C_{\text{OUT}} \times V_{\text{OUT}}}{t_{\text{START}}} \right) + I_{\text{LOAD}} + \left(\frac{I_{\text{RIPPLE}}}{2} \right) \quad (13)$$

The short-circuit limit programming resistor (R_{ILIM}) is calculated from [Equation 14](#).

$$R_{ILIM} = \frac{I_{SCP} \times R_{DS(\text{onMAX})} + V_{ILIM(\text{offset})}}{I_{ILIM}} \quad \Omega$$

where

- I_{ILIM} is the current into the ILIM pin (110 μA , typical)
 - $V_{ILIM(\text{offset})}$ is the offset voltage of the ILIM comparator (-50 mV, typical)
 - I_{SCP} is the short-circuit protection current
- (14)

To find the range of the overcurrent values, use [Equation 15](#) and [Equation 16](#).

$$I_{SCP(\max)} = \frac{1.09 \times I_{ILIM(\max)} \times R_{ILIM} - 0.09 \times R_{VDD} \times I_{R_{VDD}} - 0.045 \text{ V} + 75 \text{ mV}}{R_{DS(\text{ON})\min}} \quad (\text{A}) \quad (15)$$

$$I_{SCP(\min)} = \frac{1.09 \times I_{ILIM(\min)} \times R_{ILIM} - 0.09 \times R_{VDD} \times I_{R_{VDD}} - 0.045 \text{ V} + 30 \text{ mV}}{R_{DS(\text{ON})\max}} \quad (\text{A}) \quad (16)$$

Programming (continued)

The TPS40077 provides short-circuit protection only. Therefore, it is recommended that the minimum short-circuit protection level be placed at least 20% above the maximum output current required from the converter. The maximum output of the converter should be the steady state maximum output plus any transient specification that may exist.

The ILIM capacitor maximum value can be found from [Equation 17](#).

$$C_{ILIM(max)} = \frac{V_{OUT} \times 0.2}{V_{IN} \times R_{ILIM} \times f_{SW}} \text{ (Farads)} \quad (17)$$

Note that this is a recommended maximum value. If a smaller value can be used, it should be. For most applications, consider using half the maximum value above.

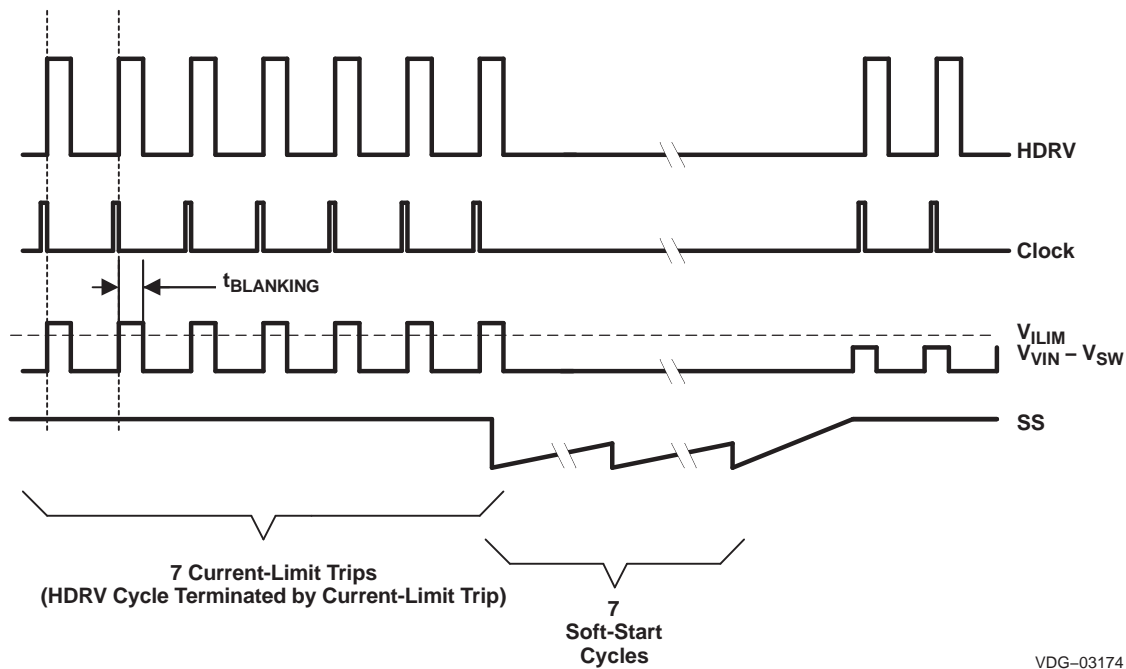

Figure 27. Typical Fault Protection Waveforms

8 Application and Implementation

NOTE

Information in the following applications sections is not part of the TI component specification, and TI does not warrant its accuracy or completeness. TI's customers are responsible for determining suitability of components for their purposes. Customers should validate and test their design implementation to confirm system functionality.

8.1 Application Information

The TPS40077 allows the user to construct synchronous voltage-mode buck converters with inputs ranging from 4.5 V to 28 V and outputs as low as 700 mV. Predictive Gate Drive circuitry optimizes switching delays for increased efficiency and improved converter output-power capability. Voltage feed-forward is employed to ease loop compensation for wide-input-range designs and provide better line transient response.

The TPS40077 incorporates circuitry to allow startup into a preexisting output voltage without sinking current from the source of the preexisting output voltage. This avoids damaging sensitive loads at start-up. An integrated power-good indicator is available for logic (open-drain) output of the condition of the output of the converter.

8.2 Typical Applications

8.2.1 Buck Regulator 8-V to 16-V Input, 1.8-V Output at 10 A

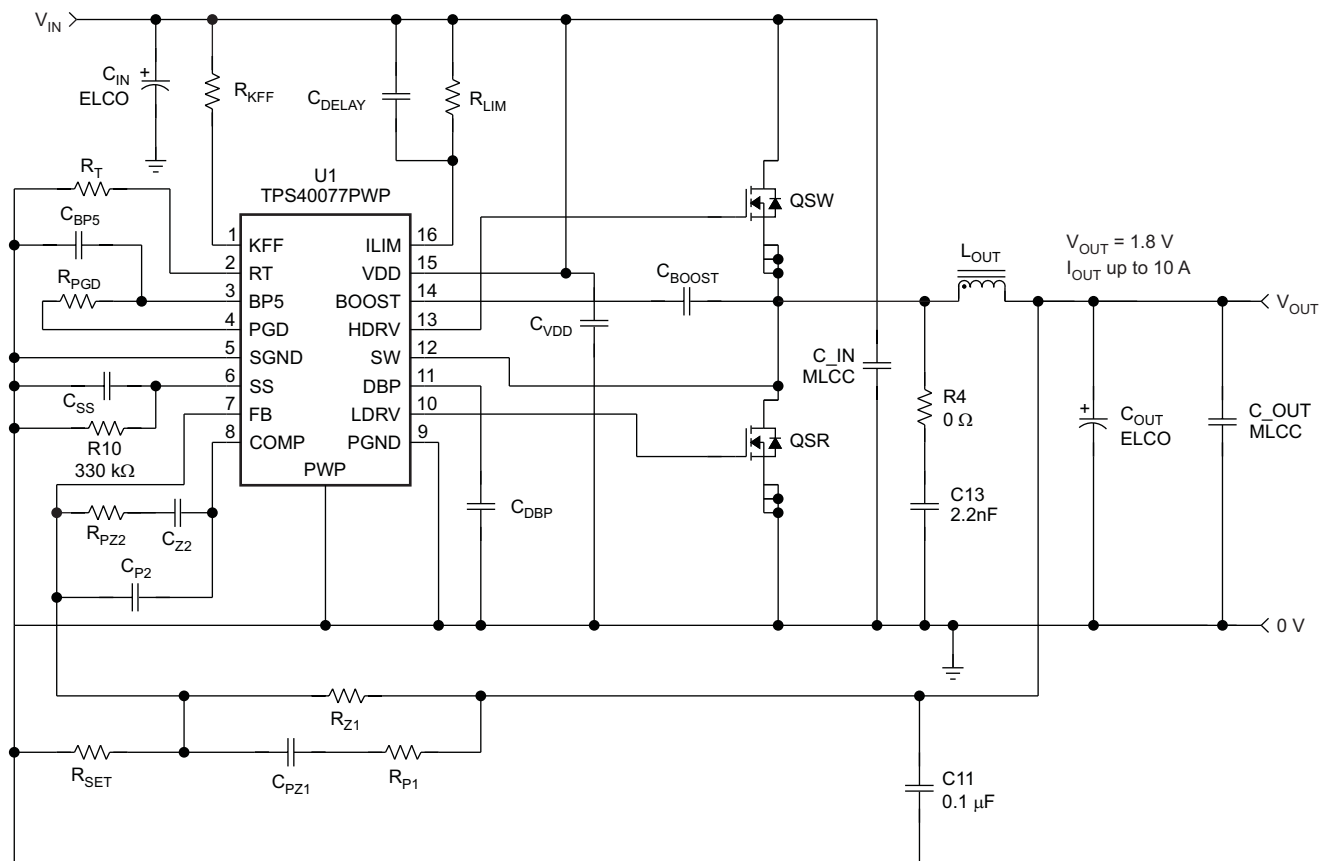

S0239-01

Figure 28. Schematic Diagram

8.2.1.1 Design Requirements

Table 3 lists the design specifications and Table 4 lists the bill of materials for this buck regulator application example.

Typical Applications (continued)
Table 3. Characteristics

PARAMETER	NOTES AND CONDITIONS	MIN	NOM	MAX	UNITS		
INPUT CHARACTERISTICS							
V_{IN}	Input voltage	8	12	16	V		
I_{IN}	Input current	$V_{IN} = \text{NOM}, I_{OUT} = \text{MAX}$		1.8	A		
	No-load input current	$V_{IN} = \text{NOM}, I_{OUT} = 0 \text{ A}$		62.6	mA		
V_{IN_UVLO}	Input UVLO	$I_{OUT} = \text{MIN to MAX}$		5.4	6	V	
V_{IN_ONV}	Input ONV	$I_{OUT} = \text{MIN to MAX}$		6.3	7	7.7	V
OUTPUT CHARACTERISTICS							
V_{OUT}	Output voltage	$V_{IN} = \text{NOM}, I_{OUT} = \text{NOM}$		1.75	1.8	1.85	V
	Line regulation ⁽¹⁾	$V_{IN} = \text{MIN to MAX}, I_{OUT} = \text{NOM}$				0.5%	
	Load regulation ⁽¹⁾	$V_{IN} = \text{NOM}, I_{OUT} = \text{MIN to MAX}$				0.5%	
V_{OUT_ripple}	Output voltage ripple	$V_{IN} = \text{NOM}, I_{OUT} = \text{MAX}$				100	mVpp
I_{OUT}	Output current	$V_{IN} = \text{MIN to MAX}$		0	5	10	A
I_{OCP}	Output overcurrent inception point	$V_{IN} = \text{NOM}, V_{OUT} = V_{OUT} - 5\%$		12.25	19.4	34	A
V_{OVP}	Output OVP	$I_{OUT} = \text{MIN to MAX}$		NA	NA	NA	
Transient response							
ΔI	Load step	I_{OUT_Max} to $0.2 \times I_{OUT_Max}$				8	A
	Load slew rate					10	A/ μs
	Overshoot					200	mV
	Settling time					1	ms
SYSTEM CHARACTERISTICS							
f_{SW}	Switching frequency	240	300	360			kHz
η_{pk}	Peak efficiency	$V_{IN} = \text{NOM}, I_{OUT} = \text{MIN to MAX}$				90%	
η	Full-load efficiency	$V_{IN} = \text{NOM}, I_{OUT} = \text{MAX}$				90%	
T_{op}	Operating temperature range	$V_{IN} = \text{MIN to MAX}, I_{OUT} = \text{MIN to MAX}$		-40	25	85	°C
MECHANICAL CHARACTERISTICS							
L	Width			2			Inches
				5.08			cm
W	Length			3			Inches
				7.62			cm
h	Component height			0.41			Inch
				1.04			cm

(1) Voltage accuracy is dependent on resistor tolerance and reference accuracy. Line and load regulation are calculated with respect to the actual set point voltage.

Table 4. Bill of Materials

REFDES	COUNT	VALUE	DESCRIPTION	SIZE	PART NUMBER	MFR
C1	1	470 μF	Capacitor, aluminum, 470- μF , 25-V, 20%	0.457 x 0.406	EEVFK1E471P	Panasonic
C2, C10	2	0.1 μF	Capacitor, ceramic, 25-V, X7R, 20%	0603	Std	Vishay
C3	1	15 nF	Capacitor, ceramic, 25-V, X7R 20%	0603	Std	Vishay
C4	1	47 pF	Capacitor, ceramic, 25-V, X7R, 20%	0603	Std	Vishay
C5	1	1.8 nF	Capacitor, ceramic, 25-V, X7R 20%	0603	Std	Vishay
C6	1	680 pF	Capacitor, ceramic, 25-V, X7R 20%	0603	Std	Vishay
C7	1	51 pF	Capacitor, ceramic, 25-V, COG 20%	0603	Std	Vishay
C8, C11	2	0.1 μF	Capacitor, ceramic, 25-V, X7R, 20%	0603	Std	Vishay

Table 4. Bill of Materials (continued)

REFDES	COUNT	VALUE	DESCRIPTION	SIZE	PART NUMBER	MFR
C9	1	1 μF	Capacitor, ceramic, 25-V, X7R, 20%	0805	Std	Vishay
C12, C14, C15	3	22 μF	Capacitor, ceramic, 22-μF, 16-V, X5R, 20%	1812	C4532X5R1C226MT	TDK
C13	1	2.2 nF	Capacitor, ceramic, 25-V, X7R, 20%	0603	Std	Vishay
C16	1	470 μF	Capacitor, aluminum, SM, 6.3-V, 300-mΩ (FC series)	8 x 10	Std	Panasonic
C17	1	47 μF	Capacitor, ceramic, 47-μF, 6.3-V, X5R, 20%	1812	C4532X5R0J476MT	TDK
D1	1	BAT54	Diode, Schottky, 200-mA, 30-V	SOT23	BAT54	Vishay
J1, J2	2	ED1609-ND	Terminal block, 2-pin, 15-A, 5.1-mm	0.40 x 0.35	ED1609	OST
J3	1	PTC36SAAN	Header, 2-pin, 100-mil spacing, (36-pin strip)	0.100 x 2	PTC36SAAN	Sullins
L1	1	2.5 μH	Inductor, SMT, 2.5 μH, 16.5-A, 3.4-mΩ	0.515 x 0.516	MLC1550-252ML	Coilcraft
Q1	1	Si7860DP	MOSFET, N-channel, 30-V, 18-A, 8.0-mΩ	PWRPAK S0-8	Si7860DP	Vishay
Q2	1	Si7336ADP	MOSFET, N-channel, 30-V, 18-A, 40-mΩ	PWRPAK S0-8	Si7886ADP	Vishay
Q3	1	FDV301N	MOSFET, N-channel, 25-V, 220-mA, 5-Ω	SOT23	FDV301N	Fairchild
R1	1	10 kΩ	Resistor, chip, 1/16-W, 20%	0603	Std	Std
R2, R6	2	165 kΩ	Resistor, Chip, 1/16-W, 20%	0603	Std	Std
R3	1	32.4 kΩ	Resistor, chip, 1/16-W, 20%	0603	Std	Std
R4, R11	2	0 Ω	Resistor, chip, 1/16-W, 20%	0603	Std	Std
R5	1	21.5 kΩ	Resistor, chip, 1/16-W, 20%	0603	Std	Std
R7	1	51 kΩ	Resistor, chip, 1/16-W, 20%	0603	Std	Std
R8	1	3.3 kΩ	Resistor, chip, 1/16-W, 20%	0603	Std	Std
R9	1	1.8 kΩ	Resistor, chip, 1/16-W, 20%	0603	Std	Std
R10	1	330 kΩ	Resistor, chip, 1/16-W, 20%	0603	Std	Std
R12	1	51 Ω	Resistor, chip, 1/16-W, 20%	0603	Std	Std
R13	1	1 kΩ	Resistor, chip, 1/16-W, 20%	0603	Std	Std
U1	1	TPS40077PWP	IC, Texas Instruments	PWP16	TPS40077PWP	TI

8.2.1.2 Detailed Design Procedure

8.2.1.2.1 Power Train Components

8.2.1.2.1.1 Output Inductor, L_{OUT}

The output inductor is one of the most important components to select. It stores the energy necessary to keep the output regulated when the switch FET is turned off. The value of the output inductor dictates the peak and RMS currents in the converter. These currents are important when selecting other components. Equation 18 can be used to calculate a value for L_{OUT} for this module which operates at a switching frequency (f) of 300 kHz.

$$L_{OUT} = \frac{V_{OUT}}{V_{IN(max)}} \times \frac{V_{IN(max)} - V_{OUT}}{f_s \times I_{RIPPLE}} \quad (18)$$

I_{RIPPLE} is the allowable ripple in the inductor. Select I_{RIPPLE} to be between 20% and 30% of maximum I_{OUT}. For this design, I_{RIPPLE} of 2.5 A was selected. Calculated L_{OUT} is 2.13 μH. A standard inductor with value of 2.5 μH was chosen. This will reduce I_{RIPPLE} by about 17% to 2.07 A.

This I_{RIPPLE} value can be used calculate the rms and peak current flowing in L_{OUT} with Equation 19. Note that this peak current is also seen by the switching FET and synchronous rectifier.

$$I_{\text{L_OUT_RMS}} = \sqrt{I_{\text{OUT}}^2 + \frac{I_{\text{RIPPLE}}^2}{12}} = 10.02 \text{ A} \quad (19)$$

The power loss from the selected inductor DCR is 357 mW. The ac core loss for this Coilcraft inductor may be found from the Coilcraft Web site, where there is a [loss calculator](#). The loss is 179 mW calculated with [Equation 20](#).

$$I_{\text{PK}} = I_{\text{OUT}} + \frac{I_{\text{RIPPLE}}}{2} = 11.03 \text{ A} \quad (20)$$

The inductor is selected with a saturation current higher than this current plus the current that is developed charging the output capacitance during the soft-start interval.

8.2.1.2.1.2 Output Capacitor, COUT, ELCO and MLCC

Several parameters must be considered when selecting the output capacitor. The capacitance value should be selected based on the output overshoot, V_{OVER} , and undershoot, V_{UNDER} , during a transient load, I_{STEP} , on the converter. The equivalent series resistance (ESR) is chosen to allow the converter to meet the output ripple specification, V_{RIPPLE} . The voltage rating must be greater than the maximum output voltage. Another parameter to consider is equivalent series inductance, which is important in fast-transient load situations. Also, size and technology can be factors when choosing the output capacitor. In this design, a large-capacitance electrolytic type capacitor, COUT ELCO, is used to meet the overshoot and undershoot specifications. Its ESR is chosen to meet the output ripple specification. Smaller multiple-layer ceramic capacitors, COUT MLCC, are used to filter high-frequency noise.

The minimum required capacitance and maximum ESR can be calculated using [Equation 21](#), [Equation 22](#), and [Equation 23](#).

$$C_{\text{OUT}} = \frac{L_{\text{OUT}} \times I_{\text{STEP}}^2}{2 \times V_{\text{UNDER}} \times D_{\text{max}} \times (V_{\text{IN}} - V_{\text{OUT}})} \quad (21)$$

$$C_{\text{OUT}} = \frac{L_{\text{OUT}} \times I_{\text{STEP}}^2}{2 \times V_{\text{OVER}} \times V_{\text{OUT}}} \quad (22)$$

$$\text{ESR} = \frac{V_{\text{RIPPLE}}}{I_{\text{RIPPLE}}} \quad (23)$$

The capacitance for COUT should be greater than 444 μF , and its ESR should be less than 12 m Ω . The 470- $\mu\text{F}/6.3\text{-V}$ capacitor from Panasonic's FC series was chosen. Its ESR is 160 m Ω . MLCCs of 47 μF and 22 $\mu\text{F}/16 \text{ V}$ are also added in parallel to achieve the required ESR and to reduce high-frequency noise.

8.2.1.2.1.3 Input Capacitor, CIN ELCO and MLCC

The input capacitor is selected to handle the ripple current of the buck stage. Also, a relatively large capacitance is used to keep the ripple voltage on the supply line low. This is especially important where the supply line has high impedance. It is recommended however, that the supply-line impedance be kept as low as possible.

The input-capacitor ripple current can be calculated using [Equation 24](#).

$$I_{\text{CAP(RMS)}} = \sqrt{\left[\left(I_{\text{OUT}} - I_{\text{IN(AVG)}} \right)^2 + \frac{I_{\text{RIPPLE}}^2}{12} \right] \times D + I_{\text{IN(AVG)}}^2 \times (1 - D)} \quad (24)$$

$I_{\text{IN(AVG)}}$ is the average input current. This is calculated simply by multiplying the output dc current by the duty cycle. The ripple current in the input capacitor is 3.3 A. An 1812 MLCC using X5R material has a typical dissipation factor of 5%. For a 22- μF capacitor at 300 kHz, the ESR is approximately 4 m Ω . Two capacitors are used in parallel, so the power dissipation in each capacitor is less than 11 mW.

A 470- $\mu\text{F}/16\text{-V}$ electrolytic is added to maintain the voltage on the input rail.

8.2.1.2.1.4 Switching MOSFET, QSW

The following key parameters must be met by the selected MOSFET.

- Drain source voltage, V_{ds} , must be able to withstand the input voltage plus spikes that may be on the switching node. For this design a V_{ds} rating of 30 volts is recommended.
- Drain current, I_D , at 25°C, must be greater than that calculated using [Equation 25](#).

$$I_{QSW(RMS)} = \sqrt{\frac{V_{OUT}}{V_{IN(MIN)}} \times \left[I_{OUT(MAX)}^2 + \frac{I_{RIPPLE}^2}{12} \right]} \quad (25)$$

- With the parameters specified, the calculation of $I_{QSW(RMS)}$ should be greater than 5 A.
- Gate source voltage, V_{gs} , must be able to withstand the gate voltage from the control IC. For the TPS40077, this is 11 V.

Once the above boundary parameters are defined, the next step in selecting the switching MOSFET is to select the key performance parameters. Efficiency is the performance characteristic which drives the other selection criteria. Target efficiency for this design is 90%. Based on 1.8-V output and 10 A, this equates to a power loss in the converter of 1.8 W. Based on this figure, a target of 0.6 W dissipated in the switching FET was chosen.

[Equation 26](#) through [Equation 29](#) can be used to calculate the power loss, P_{QSW} , in the switching MOSFET.

$$P_{QSW} = P_{CON} + P_{SW} + P_{GATE} \quad (26)$$

$$P_{CON} = R_{DS(on)} \times I_{QSW(RMS)}^2 = R_{DS(on)} \times \frac{V_{OUT}}{V_{IN}} \times \left[I_{out}^2 + \frac{I_{RIPPLE}^2}{12} \right] \quad (27)$$

$$P_{SW} = V_{IN} \times f_S \times \left[\frac{\left(I_{OUT} + \frac{I_{RIPPLE}}{2} \right) \times (Q_{gs1} + Q_{gd})}{I_g} + \frac{Q_{OSS(SW)} + Q_{OSS(SR)}}{12} \right] \quad (28)$$

$$P_{GATE} = Q_{g(TOT)} \times V_g \times f_{SW} \quad (29)$$

where

P_{CON} = conduction losses

P_{SW} = switching losses

P_{GATE} = gate-drive losses

Q_{gd} = drain-source charge or Miller charge

Q_{gs1} = gate-source post-threshold charge

I_g = gate-drive current

$Q_{OSS(SW)}$ = switching MOSFET output charge

$Q_{OSS(SR)}$ = synchronous MOSFET output charge

$Q_{g(TOT)}$ = total gate charge from zero volts to the gate voltage

V_g = gate voltage

If the total estimated loss is split evenly between conduction and switching losses, [Equation 27](#) and [Equation 28](#) yield preliminary values for $R_{DS(on)}$ and $(Q_{gs1} + Q_{gd})$. Note output losses due to Q_{OSS} and gate losses have been ignored here. Once a MOSFET is selected, these parameters can be added.

The switching MOSFET for this design should have an $R_{DS(on)}$ of less than 8 mΩ. The sum of Q_{gd} and Q_{gs} should be approximately 4 nC.

It may not always be possible to get a MOSFET which meets both these criteria, so a compromise may be necessary. Also, by selecting different MOSFETs close to these criteria and calculating power loss, the final selection can be made. It was found that the Si7860DP MOSFET from Vishay semiconductor gave reasonable results. This device has an $R_{DS(on)}$ of 8 m Ω and a ($Q_{gs1} + Q_{gd}$) of 5 nC. The estimated conduction losses are 0.115 W and the switching losses are 0.276 W. This gives a total estimated power loss of 0.391 W versus 0.6 W for our initial boundary condition. Note this does not include gate losses of approximately 71 mW and output losses of 20 mW.

8.2.1.2.1.5 Rectifier MOSFET, QSR

Similar criteria to the foregoing can be used for the rectifier MOSFET. There is one significant difference: due to the body diode conducting, the rectifier MOSFET switches with zero voltage across its drain and source, so effectively with zero switching losses. However, there are some losses in the body diode. These are minimized by reducing the delay time between the transition from the switching MOSFET turnoff to rectifier MOSFET turnon and vice-versa. The TPS40077 incorporates TI's proprietary Predictive Gate Drive circuitry (PGD), which helps reduce these delays to around 10 ns.

To calculate the losses in the rectifier MOSFET, use [Equation 30](#) through [Equation 33](#).

$$P_{QSR} = P_{CON} + P_{BD} + P_{GATE} \quad (30)$$

$$P_{CON} = R_{DS(on)} \times \left[1 - \frac{V_{OUT}}{V_{IN}} - (t_1 + t_2) \times f_S \right] \times \left[I_{out}^2 + \frac{I_{RIPPLE}^2}{12} \right] \quad (31)$$

$$P_{BD} = V_f \times I_{OUT} \times (t_1 + t_2) \times f_S \quad (32)$$

$$P_{GATE} = Q_{g(TOTAL)} \times V_g \times f_S$$

where

- P_{BD} = body diode losses
 - t_1 = body diode conduction prior to turnon of channel = 12 ns for PGD
 - t_2 = body diode conduction after turnoff of channel = 12 ns for PGD
 - V_f = body diode forward voltage
- (33)

Estimating the body diode losses based on a forward voltage of 1 V gives 0.072 W. The gate losses are unknown at this time, so assume 0.1-W gate losses. This leaves 0.428 W for conduction losses. Using this figure, a target $R_{DS(on)}$ of 5 m Ω was calculated.

The Si7336ADP from Vishay was chosen. Using the parameters from its data sheet, the actual expected power losses are calculated. Conduction loss is 0.317 W, body diode loss is 0.072 W, and the gate loss is 0.136W. This totals 0.525 W associated with the rectifier MOSFET.

Two other criteria should be verified before finalizing on the rectifier MOSFET. One is the requirement to ensure that predictive gate drive functions correctly. The turnoff delay of the Si7336ADP is 97 ns. The minimum turnoff delay of the Si7860DP is 25 ns. Together these devices meet the 130-ns requirement.

Secondly, the ratio between C_{gs} and C_{gd} should be greater than 1. The Si7336ADP easily meets this criterion. This helps reduce the risk of dv/dt -induced turnon of the rectifier MOSFET. If this is likely to be a problem, a small resistor may be added in series with the boost capacitor, CBOOST.

8.2.1.2.1.6 Timing Resistor, R_T

The timing resistor is calculated using [Equation 34](#).

$$R_T = \frac{1}{f_S \times 17.82 \times 10^{-6}} - 23 \quad (34)$$

This gives a resistor value of 165 k Ω . The nominal frequency using this resistor is 300 kHz.

8.2.1.2.1.7 Feed-Forward and UVLO Resistor, R_{KFF}

A resistor connected to the KFF pin of the IC feeds into the ramp generator. This resistor provides current into the ramp generator proportional to the input voltage. The ramp is then adjusted to compensate for different input voltages. This provides the voltage feed-forward feature of the TPS40077.

The same resistor also sets the undervoltage lockout point. The input start voltage should be used to calculate a value for R_{KFF} . For this module, the minimum input voltage is 8 V; however, due to tolerances in the IC, a start voltage of 10% less than the minimum input voltage is selected. The start voltage for R_{KFF} calculation is 7.2 V. Using Equation 35, R_{KFF} can be selected.

$$R_{KFF} = 0.131 \times R_T \times V_{UVLO(on)} - 1.61 \times 10^{-3} \times V_{UVLO(on)}^2 + 1.886 \times V_{UVLO} - 1.363 - 0.02 \times R_T - 4.87 \times 10^{-5} \times R_T^2$$

where

- R_{KFF} and R_T are in k Ω (35)

Equation 35 gives an R_{KFF} value of 156 k Ω . The closest lower standard value of 154 k Ω should be selected. This gives a minimum start voltage of 7.1 V.

8.2.1.2.1.8 Soft-Start Capacitor, CSS

It is good practice to limit the rise time of the output voltage. This helps prevent output overshoot and possible damage to the load. The selection of the soft-start time is arbitrary. It must meet one condition: it should be greater than the time constant of the output filter, LOUT and COUT. This time is given by Equation 36.

$$t_{START} \geq 2\pi \times \sqrt{LOUT \times COUT} \quad (36)$$

The soft-start time must be greater than 0.23 ms. A time of 0.75 ms was chosen. This time also helps limit the initial input current during start-up so that the peak current plus the capacitor start-up current is less than the minimum short-circuit current. The value of CSS can be calculated using Equation 37.

$$C_{SS} = \frac{I_{SS}}{V_{FB}} \times t_{START} \quad (37)$$

A standard 15-nF MLCC capacitor was chosen. The calculated start time using this capacitor is 0.875 ms.

8.2.1.2.1.9 Short-Circuit Protection, R_{ILIM} and C_{ILIM}

Short-circuit protection is programmed using the R_{ILIM} resistor. Selection of this resistor depends on the $R_{DS(on)}$ of the switching MOSFET selected and the required short-circuit current trip point, I_{SCP} . The minimum I_{SCP} is limited by the inductor peak current, the output voltage, the output capacitor, and the soft-start time. Their relationship is given by Equation 38. A short-circuit current trip point greater than that calculated by Equation 38 should be used.

$$I_{SCP} \geq \frac{COUT \times V_{OUT}}{t_{START}} + I_{PK} \quad (38)$$

The minimum short-circuit current trip point for this design is 12.25 A. This value is used in Equation 39 to calculate the minimum R_{ILIM} value.

$$R_{ILIM} = \frac{I_{SCP} \times R_{DS(on)MAX} + V_{ILIM(MAX)}}{I_{LIM(MIN)}} \quad (39)$$

R_{ILIM} is calculated to be 1.17 k Ω , and a 1.2-k Ω resistor is used to verify that the short-circuit current requirements are met. The minimum and maximum short-circuit current can be calculated using Equation 40 and Equation 41.

$$I_{SCP(MIN)} = \frac{I_{ILIM(MIN)} \times R_{ILIM(MIN)} - V_{ILIM(MAX)}}{R_{DS(on)MAX}} \quad (40)$$

$$I_{SCP(MAX)} = \frac{I_{ILIM(MAX)} \times R_{ILIM(MAX)} - V_{ILIM(MIN)}}{R_{DS(on)MIN}} \quad (41)$$

where: $V_{ILIM(MAX)}$ and $V_{ILIM(MIN)}$ are maximum and minimum voltages across the high side FET when it is turned on, taking into account temperature variations.

The minimum I_{SCP} is 12.25 A, and the maximum is 34 A.

It is also recommended to add a small capacitor, C_{ILIM} , across R_{ILIM} . The value of this capacitor should be about half the value calculated in [Equation 42](#).

$$C_{ILIM(Max)} = \frac{V_{OUT} \times 0.2}{V_{IN} \times R_{ILIM} \times f_S} \quad (42)$$

This equation yields a maximum C_{ILIM} as 55 pF. A smaller value of 27 pF is chosen.

8.2.1.2.1.10 Boost Voltage, CBOOST and DBOOST (Optional)

To be able to drive an N-channel MOSFET in the switch location of a buck converter, a capacitor charge pump or boost circuit is required. The TPS40077 contains the elements for this boost circuit. The designer must only add a capacitor, CBOOST, from the switch node of the buck power stage to the BOOST pin of the IC. Selection of this capacitor is based on the total gate charge of the switching MOSFET and the allowable ripple on the boost voltage, ΔV_{BOOST} . A ripple of 0.2 V is assumed for this design. Using these two parameters and [Equation 43](#), the minimum value for CBOOST can be calculated.

$$C_{BOOST} > \frac{Q_{g(TOTAL)}}{\Delta V_{BOOST}} \quad (43)$$

The total gate charge of the switching MOSFET is 23 nC. A minimum CBOOST of 0.092 μ F is required. A 0.1 μ F capacitor was chosen. This capacitor must be able to withstand the maximum input voltage plus the maximum voltage on DBP. This is 13.2 V plus 9.0 V, which is 22.2 V. A 50-V capacitor is used.

To reduce losses in the TPS40077 and to increase the available gate voltage for the switching MOSFET, an external diode can be added between the DBP pin and the BOOST pin of the IC. A small-signal Schottky diode should be used here, such as the BAT54.

8.2.1.2.1.11 Closing the Feedback Loop, R_{Z1} , R_{P1} , R_{PZ2} , R_{SET1} , R_{SET2} , C_{Z2} , C_{P2} , and C_{PZ1}

A graphical method is used to select the compensation components. This is a standard feed-forward buck converter. Its PWM gain is given by [Equation 44](#).

$$K_{PWM} \equiv \frac{V_{UVLO}}{1 \text{ V}} \quad (44)$$

The ramp voltage is 1 V at the UVLO voltage. Because of the feed-forward compensation, the programmed UVLO voltage is the voltage that sets the PWM gain.

The gain of the output LC filter is given by [Equation 45](#).

$$K_{LC} = \frac{1 + s \times ESR \times C_{OUT}}{1 + s \times \frac{L_{OUT}}{R_{OUT}} + s^2 \times L_{OUT} \times C_{OUT}} \quad (45)$$

The PWM and LC gain is [Equation 46](#).

$$G_c(s) = K_{PWM} \times K_{LC} \times \frac{V_{UVLO}}{1 \text{ V}} \times \frac{1 + s \times ESR \times C_{OUT}}{1 + s \times \frac{L_{OUT}}{R_{OUT}} + s^2 \times L_{OUT} \times C_{OUT}} \quad (46)$$

To plot this on a Bode plot, the dc gain must be expressed in dB. The dc gain is equal to K_{PWM} . To express this in dB, take its logarithm and multiply by 20. For this converter, the dc gain is [Equation 47](#).

$$DCGAIN = 20 \times \log \left[\frac{V_{UVLO}}{V_{RAMP}} \right] = 20 \times \log(7) = 16.9 \text{ dB} \quad (47)$$

Also, the pole and zero frequencies should be calculated. A double pole is associated with the LC and a zero is associated with the ESR of the output capacitor. The frequencies where these occur can be calculated using [Equation 48](#) and [Equation 49](#).

$$f_{LC_Pole} = \frac{1}{2\pi \times \sqrt{L_{OUT} \times C_{OUT}}} = 4.3 \text{ kHz} \quad (48)$$

$$f_{ESR_Zero} = \frac{1}{2\pi \times ESR \times C_{OUT}} = 2.1 \text{ kHz} \quad (49)$$

These are shown in the Bode plot of [Figure 29](#).

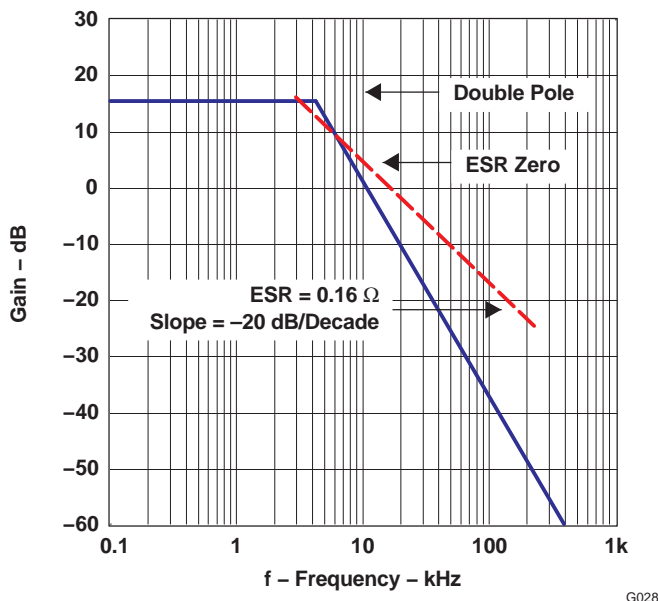

Figure 29. PWM and LC Filter Gain

The next step is to establish the required compensation gain to achieve the desired overall system response. The target response is to have the crossover frequency between 1/9 and 1/5 times the switching frequency, in order to have a phase margin greater than 45° and a gain margin greater than 6 dB.

A type-III compensation network, shown in [Figure 30](#), was used for this design. This network gives the best overall flexibility for compensating the converter.

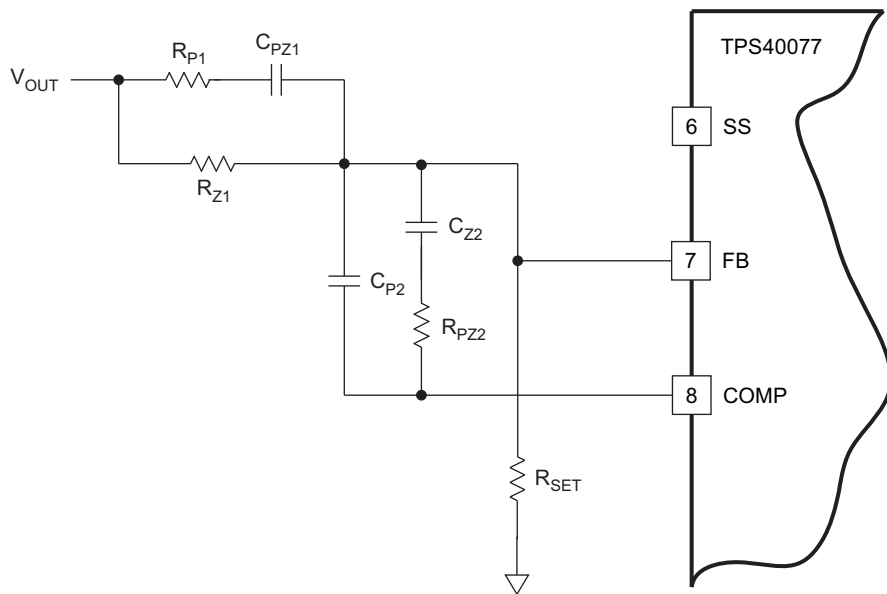

Figure 30. Type-III Compensation With the TPS40077

A typical Bode plot for this type of compensation network is shown in [Figure 31](#).

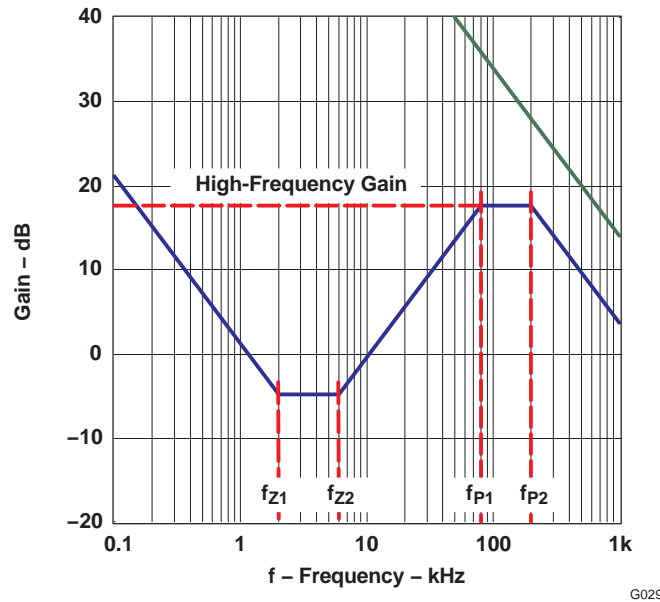

Figure 31. Type-III Compensation Typical Bode Plot

The high-frequency gain and the break (pole and zero) frequencies are calculated using Equation 50 through Equation 55.

$$V_{OUT} = V_{REF} \times \frac{R_{Z1} + R_{SET}}{R_{SET}} \tag{50}$$

$$GAIN = R_{PZ2} \times \frac{R_{Z1} + R_{P1}}{R_{Z1} \times R_{P1}} \tag{51}$$

$$f_{P1} = \frac{1}{2\pi \times R_{P1} \times C_{PZ1}} \tag{52}$$

$$f_{P2} = \frac{C_{P2} + C_{Z2}}{2\pi \times R_{PZ2} \times C_{P2} \times C_{Z2}} \approx \frac{1}{2\pi \times R_{PZ2} \times C_{P2}} \tag{53}$$

$$f_{Z1} = \frac{1}{2\pi \times R_{Z1} \times C_{PZ1}} \tag{54}$$

$$f_{Z2} = \frac{1}{2\pi \times (R_{PZ2} + R_{P1}) \times C_{Z2}} \approx \frac{1}{2\pi \times R_{PZ2} \times C_{Z2}} \tag{55}$$

Looking at the PWM and LC bode plot, there are a few things which must be done to achieve stability.

1. Place two zeros close to the double pole, e.g., $f_{z1} = f_{z2} = 4.3$ kHz
2. Place both poles well above the crossover frequency. The crossover frequency was selected as one sixth the switching frequency, $f_{co1} = 50$ kHz, $f_{p1} = 66$ kHz
3. Place the second pole at three times f_{co1} . This ensures that the overall system gain falls off quickly to give good gain margin, $f_{p2} = 150$ kHz
4. The high-frequency gain should be sufficient to ensure 0 dB at the required crossover frequency, $GAIN = -1 \times$ gain of PWM and LC at the crossover frequency, $GAIN = 16.9$ dB

Using these values and Equation 50 through Equation 55, the Rs and Cs around the compensation network can be calculated.

1. Set $R_{Z1} = 51$ k Ω
2. Calculate R_{SET} using Equation 50, $R_{SET} = 32.4$ k Ω
3. Using Equation 54 and $f_{z1} = 4.3$ kHz, C_{PZ1} can be calculated to be 726 pF, $C_{PZ1} = 680$ pF

4. f_{P1} and Equation 52 yields R_{P1} to be a standard value of 3.3 k Ω .
5. The required gain of 16.9 dB and Equation 51 sets the value for R_{PZ2} . $R_{PZ2} = 21.5$ k Ω .
6. C_{Z2} is calculated using Equation 55 and the desired frequency for the second zero, $C_{Z2} = 1.7$ nF, or using standard values, 1.8 nF.
7. Finally, C_{P2} is calculated using the second pole frequency and Equation 53; $C_{P2} = 47$ pF.

Using these values, the simulated results are 57° of phase margin at 54 kHz.

8.2.1.3 Application Curves

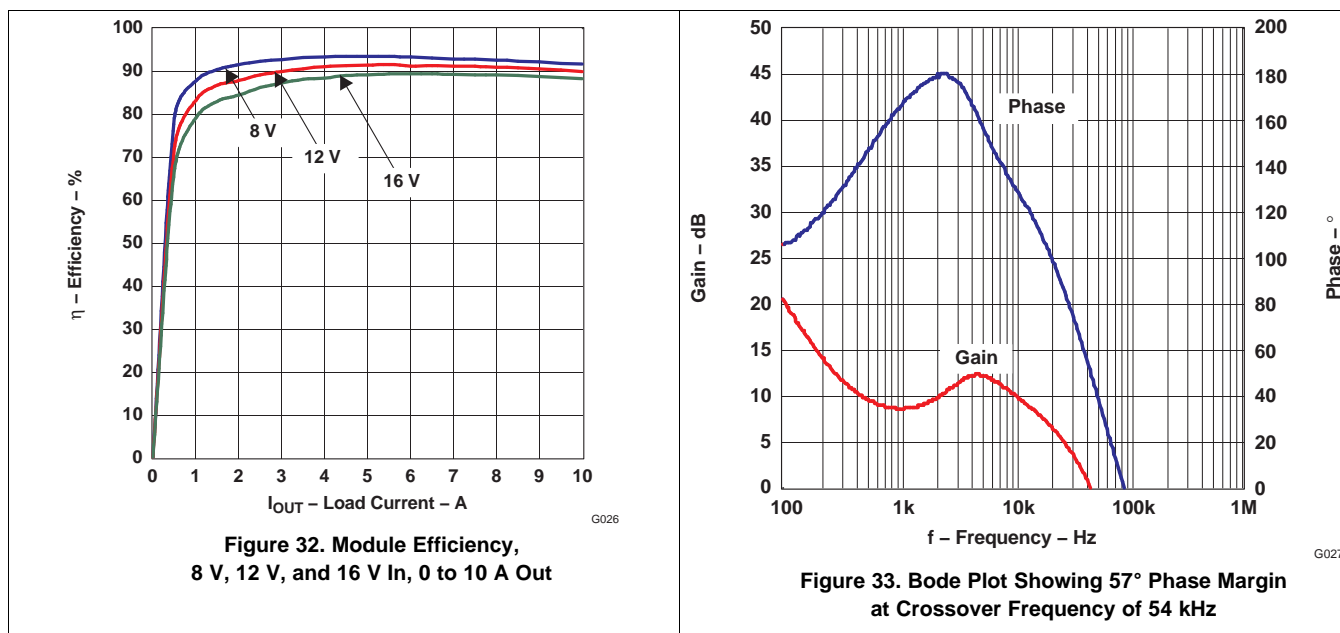

8.3 Additional System Examples

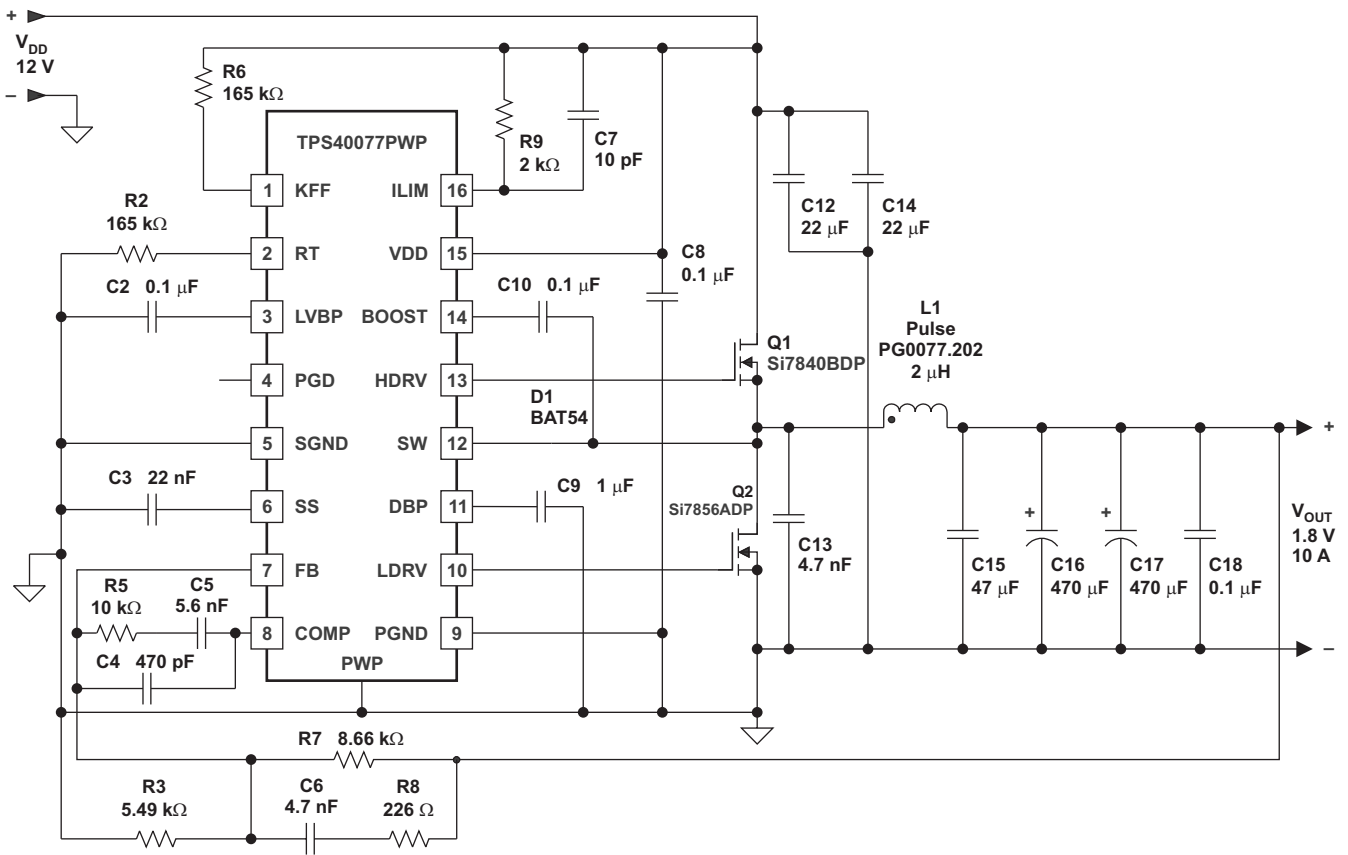

S0209-01

Figure 34. 300 kHz, 12 V to 1.8 V

Additional System Examples (continued)

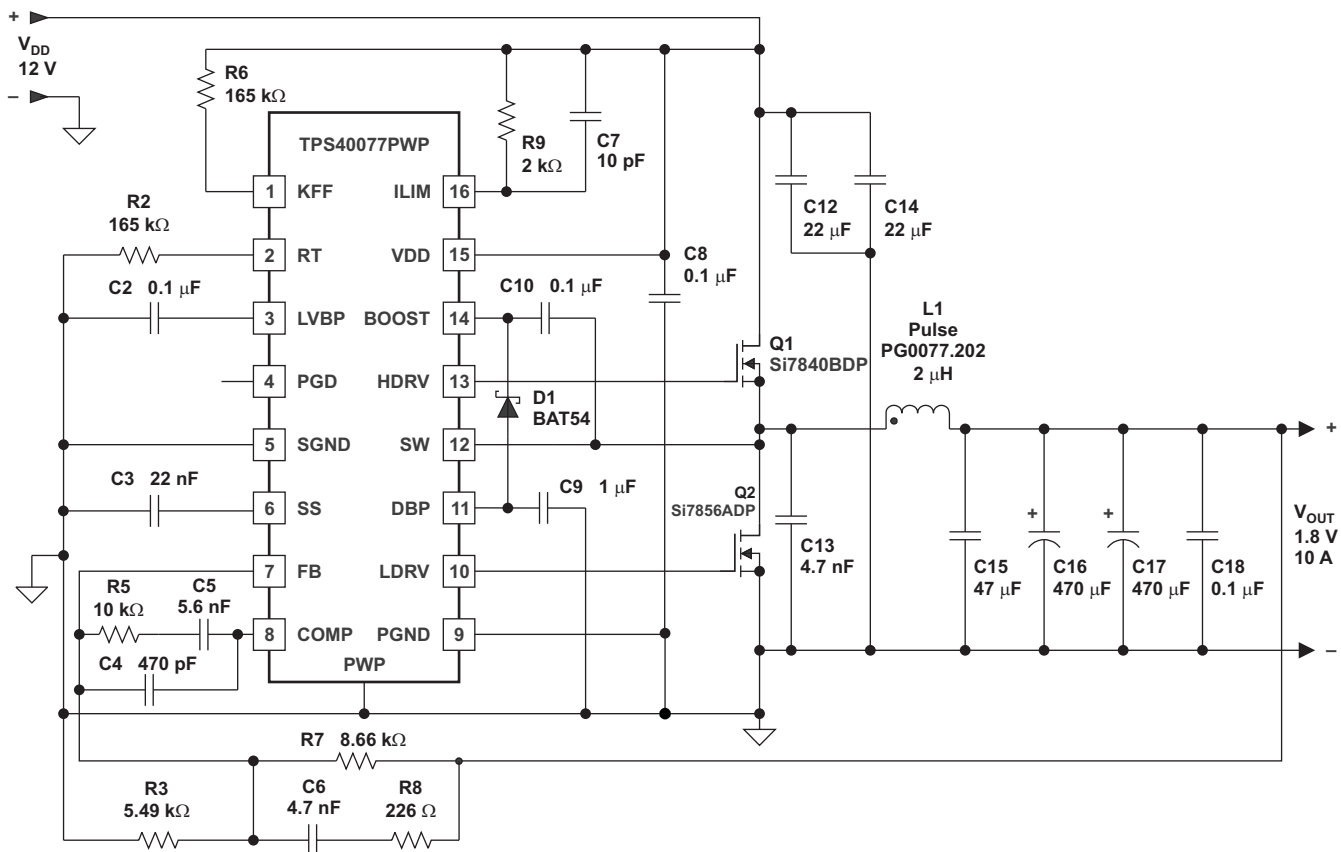

S0210-01

See [Boost Diode](#).

Figure 35. 300 kHz, 12 V to 1.8 V With Improved High-Side Gate Drive

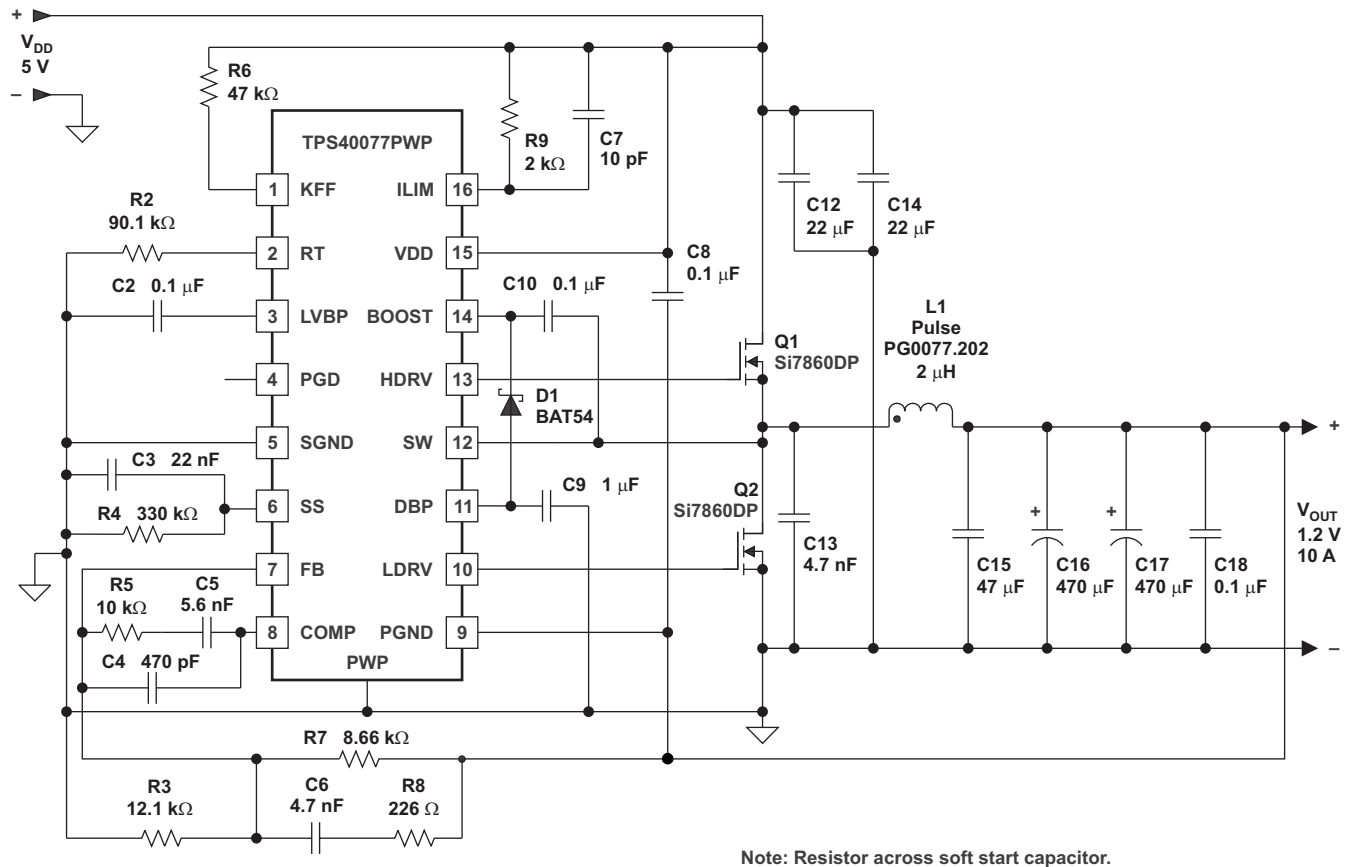
Additional System Examples (continued)

S0211-01

 See [Boost Diode](#).

Figure 36. 500 kHz, 5 V to 1.2 V With Improved High-Side Gate Drive

9 Layout

9.1 Layout Guidelines

The TPS40077 provides separate signal ground (SGND) and power ground (PGND) pins. Take care to properly separate the circuit grounds. Each ground must consist of a plane to minimize its impedance, if possible. The high-power *noisy* circuits such as the output, synchronous rectifier, MOSFET driver decoupling capacitor (DBP), and the input capacitor should be connected to PGND plane.

Connect sensitive nodes such as the FB resistor divider and RT to the SGND plane. The SGND plane must only make a single-point connection to the PGND plane. TI recommends that the SGND pin be tied to the copper area for the thermal pad underneath the chip. Tie the PGND to the thermal-pad copper area as well, and make the connection to the power circuit ground from the PGND pin. Reference the output voltage divider to the SGND pin.

Component placement must ensure that bypass capacitors (LVPB and DBP) are located as close as possible to their respective power and ground pins. Also, sensitive circuits such as FB, RT and ILIM should not be located near high-dv/dt nodes such as HDRV, LDRV, BOOST, and the switch node (SW). Failure to follow careful layout practices results in suboptimal operation. More detailed information can be found in the TPS40077EVM user's guide ([SLVU192](#)).

10 Device and Documentation Support

10.1 Device Support

10.1.1 Third-Party Products Disclaimer

TI'S PUBLICATION OF INFORMATION REGARDING THIRD-PARTY PRODUCTS OR SERVICES DOES NOT CONSTITUTE AN ENDORSEMENT REGARDING THE SUITABILITY OF SUCH PRODUCTS OR SERVICES OR A WARRANTY, REPRESENTATION OR ENDORSEMENT OF SUCH PRODUCTS OR SERVICES, EITHER ALONE OR IN COMBINATION WITH ANY TI PRODUCT OR SERVICE.

10.2 Documentation Support

10.2.1 Related Documentation

For related documentation see the following:

- *PowerPAD Thermally Enhanced Package*, [SLMA002](#)
- *TPS40190 Low Pin Count Synchronous Buck Controller*, [SLUS658](#)
- *TPS40100 Midrange Input Synchronous Buck Controller With Advanced Sequencing and Output Margining*, [SLUS601](#)
- *TPS40075 Midrange Input Synchronous Buck Controller With Voltage Feed-Forward*, [SLUS676](#)
- *TPS40057 Wide-Input Synchronous Buck Controller*, [SLUS593](#)
- *Using the TPS40077EVM 12-V Input, 1.8-V Output, 10-A Synchronous Buck Converter*, [SLVU192](#)

10.3 Receiving Notification of Documentation Updates

To receive notification of documentation updates, navigate to the device product folder on ti.com. In the upper right corner, click on *Alert me* to register and receive a weekly digest of any product information that has changed. For change details, review the revision history included in any revised document.

10.4 Community Resources

The following links connect to TI community resources. Linked contents are provided "AS IS" by the respective contributors. They do not constitute TI specifications and do not necessarily reflect TI's views; see TI's [Terms of Use](#).

TI E2E™ Online Community *TI's Engineer-to-Engineer (E2E) Community*. Created to foster collaboration among engineers. At [e2e.ti.com](#), you can ask questions, share knowledge, explore ideas and help solve problems with fellow engineers.

Design Support *TI's Design Support* Quickly find helpful E2E forums along with design support tools and contact information for technical support.

10.5 Trademarks

PowerPAD, E2E are trademarks of Texas Instruments.
All other trademarks are the property of their respective owners.

10.6 Electrostatic Discharge Caution



These devices have limited built-in ESD protection. The leads should be shorted together or the device placed in conductive foam during storage or handling to prevent electrostatic damage to the MOS gates.

10.7 Glossary

[SLYZ022](#) — *TI Glossary*.

This glossary lists and explains terms, acronyms, and definitions.

11 Mechanical, Packaging, and Orderable Information

The following pages include mechanical, packaging, and orderable information. This information is the most current data available for the designated devices. This data is subject to change without notice and revision of this document. For browser-based versions of this data sheet, refer to the left-hand navigation.

PACKAGING INFORMATION

Orderable Device	Status (1)	Package Type	Package Drawing	Pins	Package Qty	Eco Plan (2)	Lead finish/ Ball material (6)	MSL Peak Temp (3)	Op Temp (°C)	Device Marking (4/5)	Samples
TPS40077PWP	ACTIVE	HTSSOP	PWP	16	90	RoHS & Green	NIPDAU	Level-2-260C-1 YEAR	-40 to 85	40077	Samples
TPS40077PWPR	ACTIVE	HTSSOP	PWP	16	2000	RoHS & Green	NIPDAU	Level-2-260C-1 YEAR	-40 to 85	40077	Samples
TPS40077PWPRG4	ACTIVE	HTSSOP	PWP	16	2000	RoHS & Green	NIPDAU	Level-2-260C-1 YEAR	-40 to 85	40077	Samples

(1) The marketing status values are defined as follows:

ACTIVE: Product device recommended for new designs.

LIFEBUY: TI has announced that the device will be discontinued, and a lifetime-buy period is in effect.

NRND: Not recommended for new designs. Device is in production to support existing customers, but TI does not recommend using this part in a new design.

PREVIEW: Device has been announced but is not in production. Samples may or may not be available.

OBSELETE: TI has discontinued the production of the device.

(2) **RoHS:** TI defines "RoHS" to mean semiconductor products that are compliant with the current EU RoHS requirements for all 10 RoHS substances, including the requirement that RoHS substance do not exceed 0.1% by weight in homogeneous materials. Where designed to be soldered at high temperatures, "RoHS" products are suitable for use in specified lead-free processes. TI may reference these types of products as "Pb-Free".

RoHS Exempt: TI defines "RoHS Exempt" to mean products that contain lead but are compliant with EU RoHS pursuant to a specific EU RoHS exemption.

Green: TI defines "Green" to mean the content of Chlorine (Cl) and Bromine (Br) based flame retardants meet JS709B low halogen requirements of <=1000ppm threshold. Antimony trioxide based flame retardants must also meet the <=1000ppm threshold requirement.

(3) MSL, Peak Temp. - The Moisture Sensitivity Level rating according to the JEDEC industry standard classifications, and peak solder temperature.

(4) There may be additional marking, which relates to the logo, the lot trace code information, or the environmental category on the device.

(5) Multiple Device Markings will be inside parentheses. Only one Device Marking contained in parentheses and separated by a "~" will appear on a device. If a line is indented then it is a continuation of the previous line and the two combined represent the entire Device Marking for that device.

(6) Lead finish/Ball material - Orderable Devices may have multiple material finish options. Finish options are separated by a vertical ruled line. Lead finish/Ball material values may wrap to two lines if the finish value exceeds the maximum column width.

Important Information and Disclaimer:The information provided on this page represents TI's knowledge and belief as of the date that it is provided. TI bases its knowledge and belief on information provided by third parties, and makes no representation or warranty as to the accuracy of such information. Efforts are underway to better integrate information from third parties. TI has taken and continues to take reasonable steps to provide representative and accurate information but may not have conducted destructive testing or chemical analysis on incoming materials and chemicals. TI and TI suppliers consider certain information to be proprietary, and thus CAS numbers and other limited information may not be available for release.

In no event shall TI's liability arising out of such information exceed the total purchase price of the TI part(s) at issue in this document sold by TI to Customer on an annual basis.

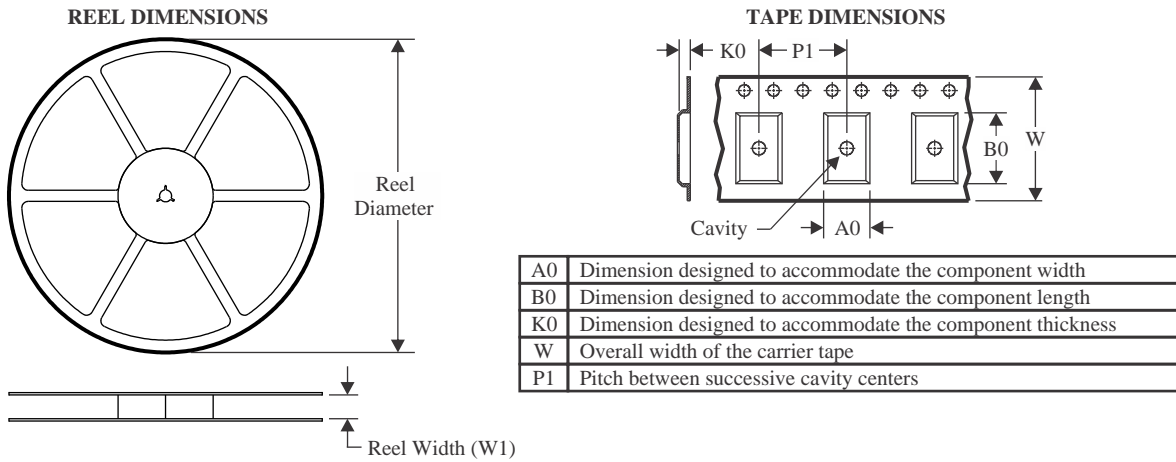
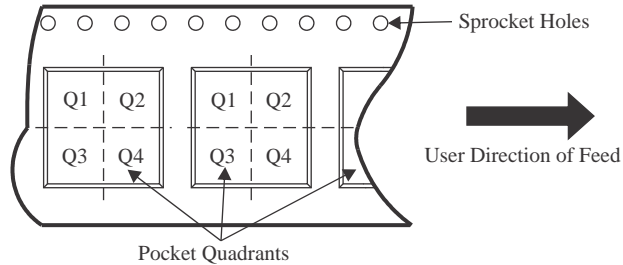
TAPE AND REEL INFORMATION

QUADRANT ASSIGNMENTS FOR PIN 1 ORIENTATION IN TAPE

*All dimensions are nominal

Device	Package Type	Package Drawing	Pins	SPQ	Reel Diameter (mm)	Reel Width W1 (mm)	A0 (mm)	B0 (mm)	K0 (mm)	P1 (mm)	W (mm)	Pin1 Quadrant
TPS40077PWPR	HTSSOP	PWP	16	2000	330.0	12.4	6.9	5.6	1.6	8.0	12.0	Q1

TAPE AND REEL BOX DIMENSIONS

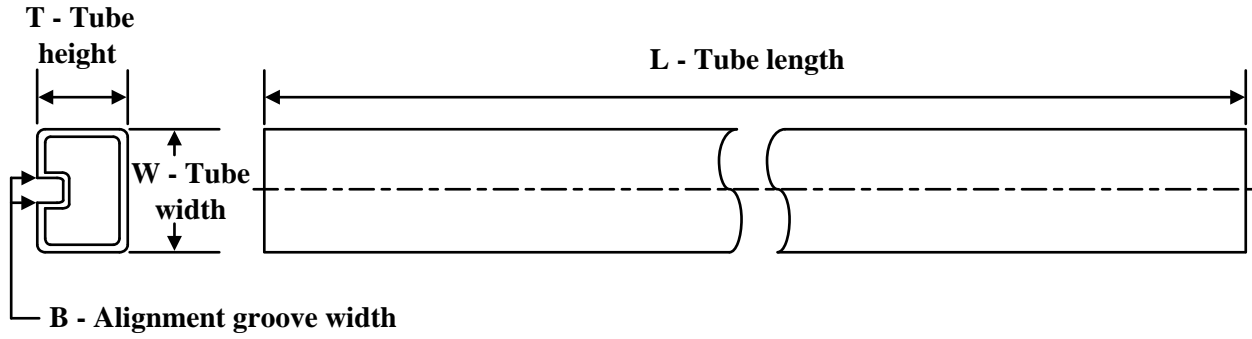

*All dimensions are nominal

Device	Package Type	Package Drawing	Pins	SPQ	Length (mm)	Width (mm)	Height (mm)
TPS40077PWPR	HTSSOP	PWP	16	2000	350.0	350.0	43.0

TUBE

*All dimensions are nominal

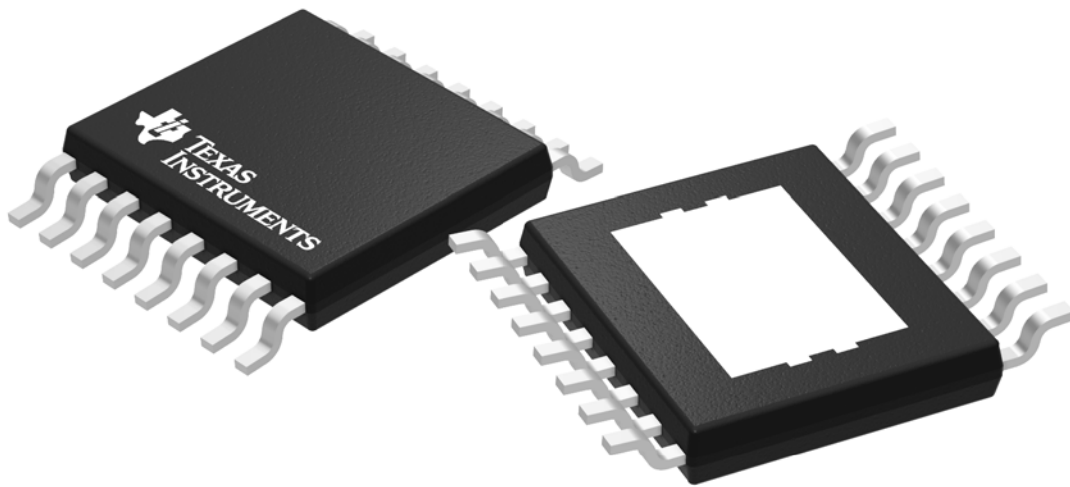
Device	Package Name	Package Type	Pins	SPQ	L (mm)	W (mm)	T (μm)	B (mm)
TPS40077PWP	PWP	HTSSOP	16	90	530	10.2	3600	3.5



Images above are just a representation of the package family, actual package may vary.
Refer to the product data sheet for package details.

PWP0016C

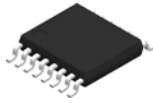

PACKAGE OUTLINE

PowerPAD™ TSSOP - 1.2 mm max height

SMALL OUTLINE PACKAGE

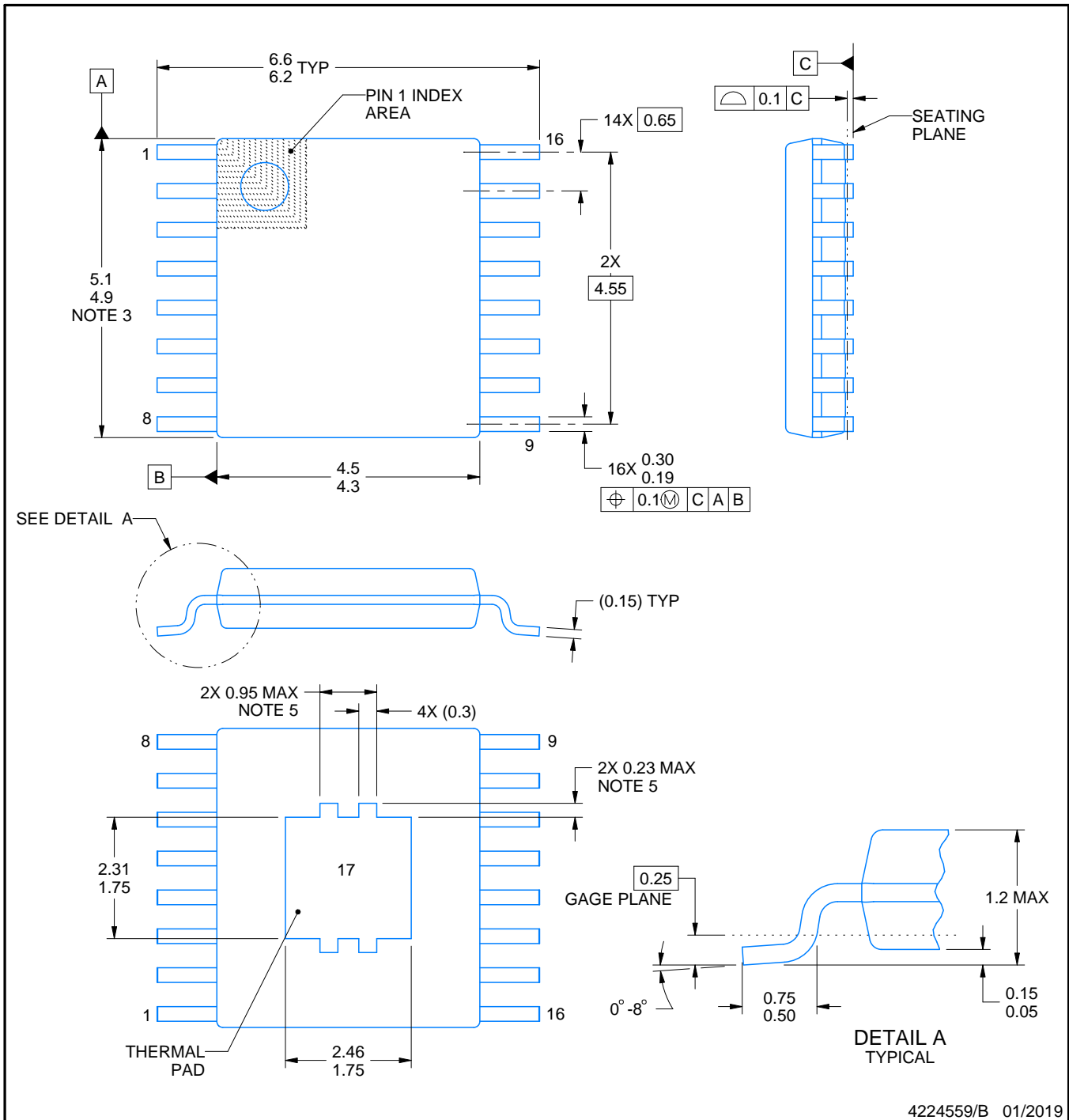

4224559/B 01/2019

NOTES:

PowerPAD is a trademark of Texas Instruments.

1. All linear dimensions are in millimeters. Any dimensions in parenthesis are for reference only. Dimensioning and tolerancing per ASME Y14.5M.
2. This drawing is subject to change without notice.
3. This dimension does not include mold flash, protrusions, or gate burrs. Mold flash, protrusions, or gate burrs shall not exceed 0.15 mm per side.
4. Reference JEDEC registration MO-153.
5. Features may differ or may not be present.

EXAMPLE BOARD LAYOUT

PWP0016C

PowerPAD™ TSSOP - 1.2 mm max height

SMALL OUTLINE PACKAGE

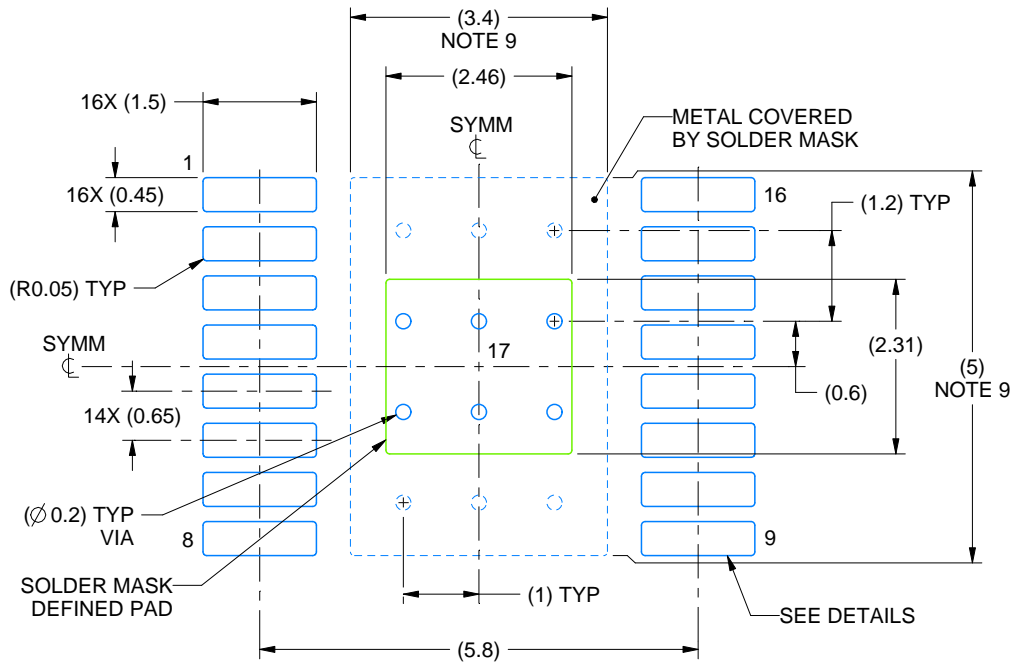

LAND PATTERN EXAMPLE
EXPOSED METAL SHOWN
SCALE: 10X

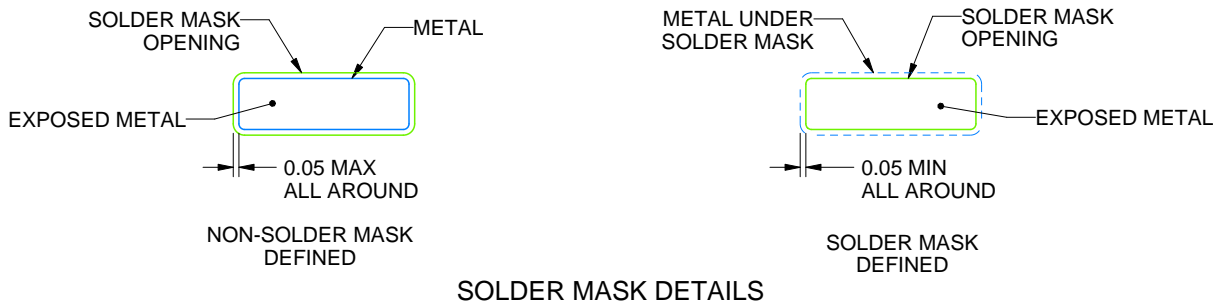

SOLDER MASK DETAILS

4224559/B 01/2019

NOTES: (continued)

6. Publication IPC-7351 may have alternate designs.
7. Solder mask tolerances between and around signal pads can vary based on board fabrication site.
8. This package is designed to be soldered to a thermal pad on the board. For more information, see Texas Instruments literature numbers SLMA002 (www.ti.com/lit/slma002) and SLMA004 (www.ti.com/lit/slma004).
9. Size of metal pad may vary due to creepage requirement.
10. Vias are optional depending on application, refer to device data sheet. It is recommended that vias under paste be filled, plugged or tented.

EXAMPLE STENCIL DESIGN

PWP0016C

PowerPAD™ TSSOP - 1.2 mm max height

SMALL OUTLINE PACKAGE

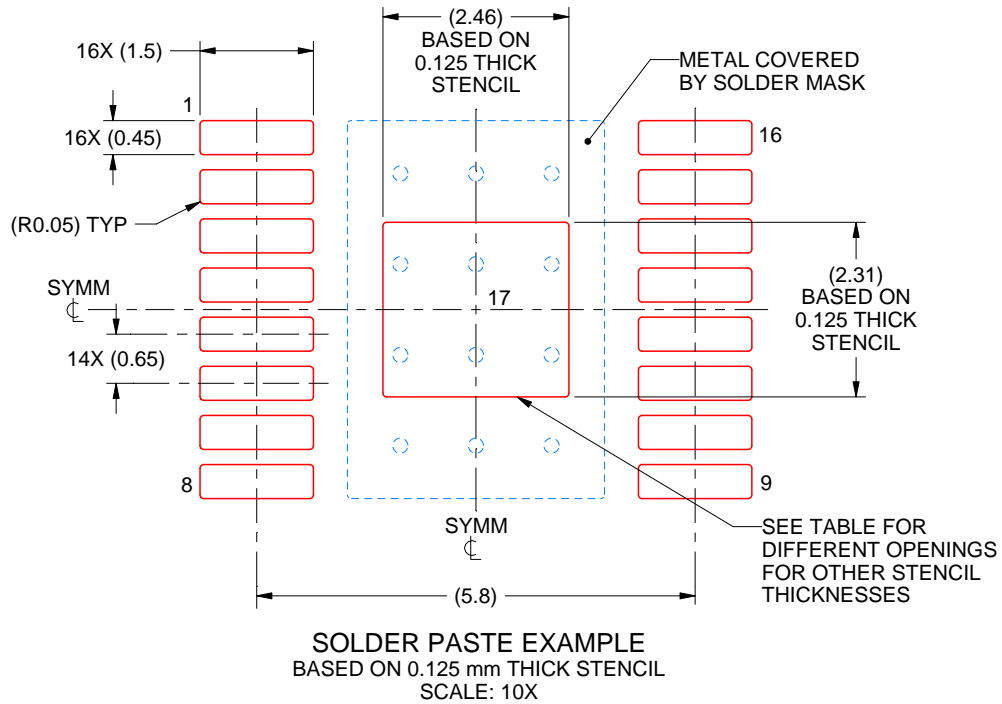

STENCIL THICKNESS	SOLDER STENCIL OPENING
0.1	2.75 X 2.58
0.125	2.46 X 2.31 (SHOWN)
0.15	2.25 X 2.11
0.175	2.08 X 1.95

4224559/B 01/2019

NOTES: (continued)

11. Laser cutting apertures with trapezoidal walls and rounded corners may offer better paste release. IPC-7525 may have alternate design recommendations.
12. Board assembly site may have different recommendations for stencil design.

IMPORTANT NOTICE AND DISCLAIMER

TI PROVIDES TECHNICAL AND RELIABILITY DATA (INCLUDING DATA SHEETS), DESIGN RESOURCES (INCLUDING REFERENCE DESIGNS), APPLICATION OR OTHER DESIGN ADVICE, WEB TOOLS, SAFETY INFORMATION, AND OTHER RESOURCES "AS IS" AND WITH ALL FAULTS, AND DISCLAIMS ALL WARRANTIES, EXPRESS AND IMPLIED, INCLUDING WITHOUT LIMITATION ANY IMPLIED WARRANTIES OF MERCHANTABILITY, FITNESS FOR A PARTICULAR PURPOSE OR NON-INFRINGEMENT OF THIRD PARTY INTELLECTUAL PROPERTY RIGHTS.

These resources are intended for skilled developers designing with TI products. You are solely responsible for (1) selecting the appropriate TI products for your application, (2) designing, validating and testing your application, and (3) ensuring your application meets applicable standards, and any other safety, security, regulatory or other requirements.

These resources are subject to change without notice. TI grants you permission to use these resources only for development of an application that uses the TI products described in the resource. Other reproduction and display of these resources is prohibited. No license is granted to any other TI intellectual property right or to any third party intellectual property right. TI disclaims responsibility for, and you will fully indemnify TI and its representatives against, any claims, damages, costs, losses, and liabilities arising out of your use of these resources.

TI's products are provided subject to [TI's Terms of Sale](#) or other applicable terms available either on [ti.com](https://www.ti.com) or provided in conjunction with such TI products. TI's provision of these resources does not expand or otherwise alter TI's applicable warranties or warranty disclaimers for TI products.

TI objects to and rejects any additional or different terms you may have proposed.

Mailing Address: Texas Instruments, Post Office Box 655303, Dallas, Texas 75265
Copyright © 2023, Texas Instruments Incorporated

Looking for pricing, stock, or lifecycle information?

Click below to explore more details on WIN SOURCE:

 [View TPS40077PWPR on WIN SOURCE](#)

 [Texas Instruments](#) Information

Optimize Your Supply Chain with WIN SOURCE Solutions

-  Global Sourcing Solution
-  Obsolete Management
-  Cost Control Management
-  Shortage Management
-  Alternative Solution
-  Excess Inventory Management