



**THE DATASHEET OF
TPS51216RUKR**



TPS51216

SLUSAB9A –NOVEMBER 2010–REVISED APRIL 2013

www.ti.com



These devices have limited built-in ESD protection. The leads should be shorted together or the device placed in conductive foam during storage or handling to prevent electrostatic damage to the MOS gates.

ORDERING INFORMATION⁽¹⁾

T _A	PACKAGE	ORDERABLE DEVICE NUMBER	PINS	OUTPUT SUPPLY	MINIMUM QUANTITY
-40°C to 85°C	Plastic Quad Flat Pack (20 pin QFN)	TPS51216RUKR	20	Tape and reel	3000
		TPS51216RUKT		Mini reel	250

(1) For the most current package and ordering information see the *Package Option Addendum* at the end of this document, or see the TI web site at www.ti.com.

ABSOLUTE MAXIMUM RATINGS⁽¹⁾

over operating free-air temperature range (unless otherwise noted)

		VALUE		UNIT
		MIN	MAX	
Input voltage range ⁽²⁾	VBST	-0.3	36	V
	VBST ⁽³⁾	-0.3	6	
	SW	-5	30	
	VLDOIN, VDDQSNS, REFIN	-0.3	3.6	
	VTTSENS	-0.3	3.6	
	PGND, VTTGND	-0.3	0.3	
	V5IN, S3, S5, TRIP, MODE	-0.3	6	
Output voltage range ⁽²⁾	DRVH	-5	36	V
	DRVH ⁽³⁾	-0.3	6	
	DRVH ⁽³⁾ (duty cycle < 1%)	-2.5	6	
	VTTREF, VREF	-0.3	3.6	
	VTT	-0.3	3.6	
	DRVL	-0.3	6	
	DRVL (duty cycle < 1%)	-2.5	6	
	PGOOD	-0.3	6	
Junction temperature range, T _J			125	°C
Storage temperature range, T _{STG}		-55	150	°C

(1) Stresses beyond those listed under absolute maximum ratings may cause permanent damage to the device. These are stress ratings only and functional operation of the device at these or any other conditions beyond those indicated under recommended operating conditions is not implied. Exposure to absolute-maximum-rated conditions for extended periods may affect device reliability.

(2) All voltage values are with respect to the network ground terminal unless otherwise noted.

(3) Voltage values are with respect to the SW terminal.

THERMAL INFORMATION

THERMAL METRIC		TPS51216	UNITS
		QFN (20) PINS	
θ _{JA}	Junction-to-ambient thermal resistance	94.1	°C/W
θ _{JCtop}	Junction-to-case (top) thermal resistance	58.1	
θ _{JB}	Junction-to-board thermal resistance	64.3	
ψ _{JT}	Junction-to-top characterization parameter	31.8	
ψ _{JB}	Junction-to-board characterization parameter	58.0	
θ _{JCbot}	Junction-to-case (bottom) thermal resistance	5.9	

RECOMMENDED OPERATING CONDITIONS

		MIN	TYP	MAX	UNIT
Supply voltage	V5IN	4.5		5.5	V
Input voltage range	VBST	-0.1		33.5	V
	VBST ⁽¹⁾	-0.1		5.5	
	SW	-3		28	
	SW ⁽²⁾	-4.5		28	
	VLDOIN, VDDQSNS, REFIN	-0.1		3.5	
	VTTSENS	-0.1		3.5	
	PGND, VTTGND	-0.1		0.1	
	S3, S5, TRIP, MODE	-0.1		5.5	
Output voltage range	DRVH	-3		33.5	V
	DRVH ⁽¹⁾	-0.1		5.5	
	DRVH ⁽²⁾	-4.5		33.5	
	VTTREF, VREF	-0.1		3.5	
	VTT	-0.1		3.5	
	DRVL	-0.1		5.5	
	PGOOD	-0.1		5.5	
T _A	Operating free-air temperature	-40		85	°C

(1) Voltage values are with respect to the SW terminal.

(2) This voltage should be applied for less than 30% of the repetitive period.

ELECTRICAL CHARACTERISTICS

 over operating free-air temperature range, $V_{V5IN}=5V$, VLDOIN is connected to VDDQ output, $V_{MODE}=0V$, $V_{S3}=V_{S5}=5V$ (unless otherwise noted)

PARAMETER		TEST CONDITION	MIN	TYP	MAX	UNIT
SUPPLY CURRENT						
$I_{V5IN(S0)}$	V5IN supply current, in S0	$T_A = 25^\circ C$, No load, $V_{S3} = V_{S5} = 5V$		590		μA
$I_{V5IN(S3)}$	V5IN supply current, in S3	$T_A = 25^\circ C$, No load, $V_{S3} = 0V$, $V_{S5} = 5V$		500		μA
$I_{V5INSDN}$	V5IN shutdown current	$T_A = 25^\circ C$, No load, $V_{S3} = V_{S5} = 0V$			1	μA
$I_{VLDOIN(S0)}$	VLDOIN supply current, in S0	$T_A = 25^\circ C$, No load, $V_{S3} = V_{S5} = 5V$			5	μA
$I_{VLDOIN(S3)}$	VLDOIN supply current, in S3	$T_A = 25^\circ C$, No load, $V_{S3} = 0V$, $V_{S5} = 5V$			5	μA
$I_{VLDOINSDN}$	VLDOIN shutdown current	$T_A = 25^\circ C$, No load, $V_{S3} = V_{S5} = 0V$			5	μA
VREF OUTPUT						
V_{VREF}	Output voltage	$I_{VREF} = 30 \mu A$, $T_A = 25^\circ C$		1.8000		V
		$0 \mu A \leq I_{VREF} < 300 \mu A$, $T_A = -10^\circ C$ to $85^\circ C$	1.7856		1.8144	
		$0 \mu A \leq I_{VREF} < 300 \mu A$, $T_A = -40^\circ C$ to $85^\circ C$	1.7820		1.8180	
$I_{VREFOCL}$	Current limit	$V_{VREF} = 1.7V$	0.4	0.8		mA
VTTREF OUTPUT						
V_{VTTREF}	Output voltage			$V_{VDDQSNS}/2$		V
V_{VTTREF}	Output voltage tolerance to V_{VDDQ}	$ I_{VTTREF} < 100 \mu A$, $1.2V \leq V_{VDDQSNS} \leq 1.8V$	49.2%		50.8%	
		$ I_{VTTREF} < 10mA$, $1.2V \leq V_{VDDQSNS} \leq 1.8V$	49%		51%	
$I_{VTTREFOCLSRC}$	Source current limit	$V_{VDDQSNS} = 1.8V$, $V_{VTTREF} = 0V$	10	18		mA
$I_{VTTREFOCLSNK}$	Sink current limit	$V_{VDDQSNS} = 1.8V$, $V_{VTTREF} = 1.8V$	10	17		mA
$I_{VTTREFDIS}$	VTTREF discharge current	$T_A = 25^\circ C$, $V_{S3} = V_{S5} = 0V$, $V_{VTTREF} = 0.5V$	0.8	1.3		mA
VTT OUTPUT						
V_{VTT}	Output voltage			V_{VTTREF}		V
V_{VTTTOL}	Output voltage tolerance to VTTREF	$ I_{VTT} \leq 10mA$, $1.2V \leq V_{VDDQSNS} \leq 1.8V$, $I_{VTTREF} = 0A$	-20		20	mV
		$ I_{VTT} \leq 1A$, $1.2 \leq V_{VDDQSNS} \leq 1.8V$, $I_{VTTREF} = 0A$	-30		30	
		$ I_{VTT} \leq 2A$, $1.4V \leq V_{VDDQSNS} \leq 1.8V$, $I_{VTTREF} = 0A$	-40		40	
		$ I_{VTT} \leq 1.5A$, $1.2V \leq V_{VDDQSNS} \leq 1.4V$, $I_{VTTREF} = 0A$	-40		40	
$I_{VTTOCLSRC}$	Source current limit	$V_{VDDQSNS} = 1.8V$, $V_{VTT} = V_{VTTNS} = 0.7V$, $I_{VTTREF} = 0A$	2	3		A
$I_{VTTOCLSNK}$	Sink current limit	$V_{VDDQSNS} = 1.8V$, $V_{VTT} = V_{VTTNS} = 1.1V$, $I_{VTTREF} = 0A$	2	3		A
I_{VTTTLK}	Leakage current	$T_A = 25^\circ C$, $V_{S3} = 0V$, $V_{S5} = 5V$, $V_{VTT} = V_{VTTREF}$			5	
$I_{VTTNSBIAS}$	VTTNS input bias current	$V_{S3} = 5V$, $V_{S5} = 5V$, $V_{VTTNS} = V_{VTTREF}$	-0.5	0.0	0.5	μA
$I_{VTTNSLK}$	VTTNS leakage current	$V_{S3} = 0V$, $V_{S5} = 5V$, $V_{VTTNS} = V_{VTTREF}$	-1	0	1	μA
I_{VTTDIS}	VTT Discharge current	$T_A = 25^\circ C$, $V_{S3} = V_{S5} = 0V$, $V_{VDDQSNS} = 1.8V$, $V_{VTT} = 0.5V$, $I_{VTTREF} = 0A$		7.8		mA
VDDQ OUTPUT						
$V_{VDDQSNS}$	VDDQ sense voltage			V_{REFIN}		
$V_{VDDQSNSTOL}$	VDDQSNS regulation voltage tolerance to REFIN	$T_A = 25^\circ C$	-3		3	mV
$I_{VDDQSNS}$	VDDQSNS input current	$V_{VDDQSNS} = 1.8V$		39		μA
I_{REFIN}	REFIN input current	$V_{REFIN} = 1.8V$	-0.1	0.0	0.1	μA
$I_{VDDQDIS}$	VDDQ discharge current	$V_{S3} = V_{S5} = 0V$, $V_{VDDQSNS} = 0.5V$, MODE pin pulled down to GND through 47k Ω (Non-tracking)		12		mA
$I_{VLDOINDIS}$	VLDOIN discharge current	$V_{S3} = V_{S5} = 0V$, $V_{VDDQSNS} = 0.5V$, MODE pin pulled down to GND through 100k Ω (Non-tracking)		1.2		A
SWITCH MODE POWER SUPPLY (SMPS) FREQUENCY						
f_{SW}	VDDQ switching frequency	$V_{IN} = 12V$, $V_{VDDQSNS} = 1.8V$, $R_{MODE} = 100k\Omega$		300		kHz
		$V_{IN} = 12V$, $V_{VDDQSNS} = 1.8V$, $R_{MODE} = 200k\Omega$		400		
$t_{ON(min)}$	Minimum on time	DRVH rising to falling ⁽¹⁾		60		ns
$t_{OFF(min)}$	Minimum off time	DRVH falling to rising	200	320	450	

(1) Ensured by design. Not production tested.

ELECTRICAL CHARACTERISTICS (continued)

 over operating free-air temperature range, $V_{V5IN}=5V$, VLDOIN is connected to VDDQ output, $V_{MODE}=0V$, $V_{S3}=V_{S5}=5V$ (unless otherwise noted)

PARAMETER		TEST CONDITION	MIN	TYP	MAX	UNIT
VDDQ MOSFET DRIVER						
R_{DRVH}	DRVH resistance	Source, $I_{DRVH} = -50\text{ mA}$		1.6	3.0	Ω
		Sink, $I_{DRVH} = 50\text{ mA}$		0.6	1.5	
R_{DRVL}	DRVL resistance	Source, $I_{DRVL} = -50\text{ mA}$		0.9	2.0	Ω
		Sink, $I_{DRVL} = 50\text{ mA}$		0.5	1.2	
t_{DEAD}	Dead time	DRVH-off to DRVL-on		10		ns
		DRVL-off to DRVH-on		20		
INTERNAL BOOT STRAP SW						
V_{FBST}	Forward Voltage	$V_{V5IN-VBST}$, $T_A = 25^\circ\text{C}$, $I_F = 10\text{ mA}$		0.1	0.2	V
I_{VBSTLK}	VBST leakage current	$T_A = 25^\circ\text{C}$, $V_{VBST} = 33\text{ V}$, $V_{SW} = 28\text{ V}$		0.01	1.5	μA
LOGIC THRESHOLD						
I_{MODE}	MODE source current		14	15	16	μA
V_{THMODE}	MODE threshold voltage	MODE 0	580	600	620	mV
		MODE 1	829	854	879	
		MODE 2	1202	1232	1262	
		MODE 3	1760	1800	1840	
V_{IL}	S3/S5 low-level voltage				0.5	V
V_{IH}	S3/S5 high-level voltage	1.8				
V_{IHYST}	S3/S5 hysteresis voltage		0.25			
V_{ILK}	S3/S5 input leak current		-1	0	1	
SOFT START						
t_{SS}	VDDQ soft-start time	Internal soft-start time, $C_{VREF} = 0.1\text{ }\mu\text{F}$, S5 rising to $V_{VDDQSNS} > 0.99 \times V_{REFIN}$		1.1		ms
PGOOD COMPARATOR						
V_{THPG}	VDDQ PGOOD threshold	PGOOD in from higher	106%	108%	110%	
		PGOOD in from lower	90%	92%	94%	
		PGOOD out to higher	114%	116%	118%	
		PGOOD out to lower	82%	84%	86%	
I_{PG}	PGOOD sink current	$V_{PGOOD} = 0.5\text{ V}$	3	5.9		mA
t_{PGDLY}	PGOOD delay time	Delay for PGOOD in	0.8	1	1.2	ms
		Delay for PGOOD out, with 100 mV over drive		330		ns
$t_{PGSSDLY}$	PGOOD start-up delay	$C_{VREF} = 0.1\text{ }\mu\text{F}$, S5 rising to PGOOD rising		2.5		ms

ELECTRICAL CHARACTERISTICS (continued)

 over operating free-air temperature range, VV5IN=5V, VLDOIN is connected to VDDQ output, V_{MODE}=0V, V_{S3}=V_{S5}=5V (unless otherwise noted)

PARAMETER		TEST CONDITION	MIN	TYP	MAX	UNIT
PROTECTIONS						
I _{TRIP}	TRIP source current	T _A = 25°C, V _{TRIP} = 0.4 V	9	10	11	μA
TC _{TRIP}	TRIP source current temperature coefficient ⁽²⁾			4700		ppm/°C
V _{TRIP}	V _{TRIP} voltage range		0.2		3	V
V _{OCL}	Current limit threshold	V _{TRIP} = 3.0 V	360	375	390	mV
		V _{TRIP} = 1.6 V	190	200	210	
		V _{TRIP} = 0.2 V	20	25	30	
V _{OCLN}	Negative current limit threshold	V _{TRIP} = 3.0 V	-390	-375	-360	mV
		V _{TRIP} = 1.6 V	-210	-200	-190	
		V _{TRIP} = 0.2 V	-30	-25	-20	
V _{ZC}	Zero cross detection offset		0			mV
V _{UVLO}	V5IN UVLO threshold voltage	Wake-up	4.2	4.4	4.5	V
		Shutdown	3.7	3.9	4.1	
V _{OVP}	VDDQ OVP threshold voltage	OVP detect voltage	118%	120%	122%	
t _{OVPDLY}	VDDQ OVP propagation delay	With 100 mV over drive		430		ns
V _{UVP}	VDDQ UVP threshold voltage	UVP detect voltage	66%	68%	70%	
t _{UVPDLY}	VDDQ UVP delay			1		ms
t _{UVPENDLY}	VDDQ UVP enable delay			1.2		ms
V _{OOB}	OOB Threshold voltage			108%		
THERMAL SHUTDOWN						
T _{SDN}	Thermal shutdown threshold	Shutdown temperature ⁽²⁾		140		°C
		Hysteresis ⁽²⁾		10		

(2) Ensured by design. Not production tested.

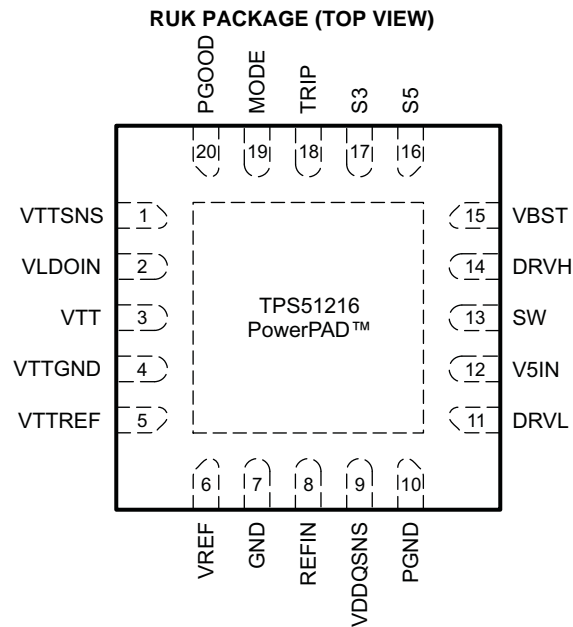
DEVICE INFORMATION

PIN FUNCTIONS

PIN		I/O	DESCRIPTION
NAME	NO.		
DRVH	14	O	High-side MOSFET gate driver output.
DRV L	11	O	Low-side MOSFET gate driver output.
GND	7	–	Signal ground.
MODE	19	I	Connect resistor to GND to configure switching frequency and discharge mode. (See Table 2)
PGND	10	–	Gate driver power ground. $R_{DS(on)}$ current sensing input(+).
PGOOD	20	O	Powergood signal open drain output. PGOOD goes high when VDDQ output voltage is within the target range.
REFIN	8	I	Reference input for VDDQ. Connect to the midpoint of a resistor divider from VREF to GND. Add a capacitor for stable operation.
SW	13	I/O	High-side MOSFET gate driver return. $R_{DS(on)}$ current sensing input(–).
S3	17	I	S3 signal input. (See Table 1)
S5	16	I	S5 signal input. (See Table 1)
TRIP	18	I	Connect resistor to GND to set OCL at $V_{TRIP}/8$. Output 10- μ A current at room temperature, $T_C = 4700$ ppm/ $^{\circ}$ C.
VBST	15	I	High-side MOSFET gate driver bootstrap voltage input. Connect a capacitor from the VBST pin to the SW pin.
VDDQSNS	9	I	VDDQ output voltage feedback. Reference input for VTTREF. Also serves as power supply for VTTREF.
VLDOIN	2	I	Power supply input for VTT LDO. Connect VDDQ in typical application.
VREF	6	O	1.8-V reference output.
VTT	3	O	VTT 2-A LDO output. Need to connect 10 μ F or larger capacitance for stability.
VTTGND	4	–	Power ground for VTT LDO.
VTTREF	5	O	Buffered VTT reference output. Need to connect 0.22 μ F or larger capacitance for stability.
VTTSENS	1	I	VTT output voltage feedback.
V5IN	12	I	5-V power supply input for internal circuits and MOSFET gate drivers.
Thermal pad	–	–	Connect to GND

TYPICAL CHARACTERISTICS

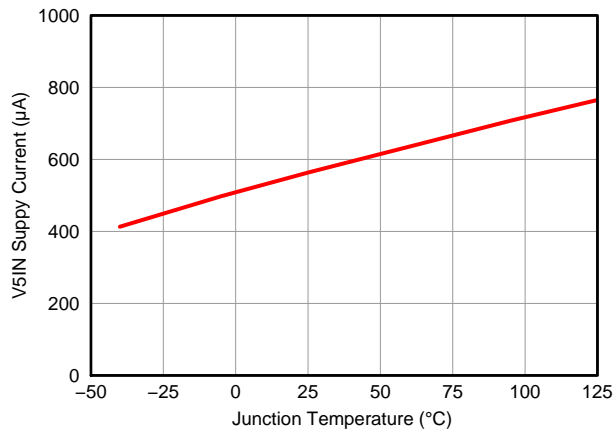

Figure 1. V5IN Supply Current vs Junction Temperature

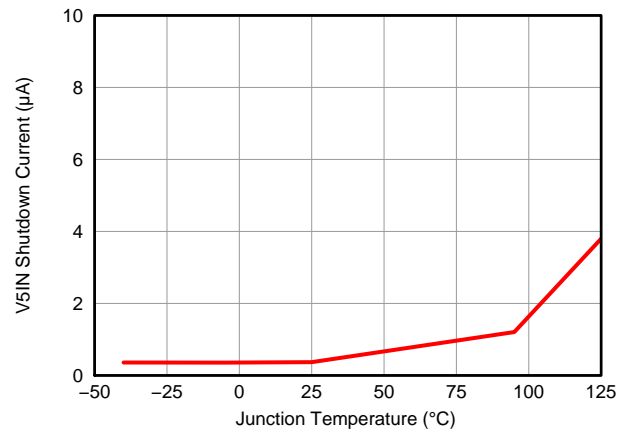

Figure 2. V5IN Shutdown Current vs Junction Temperature

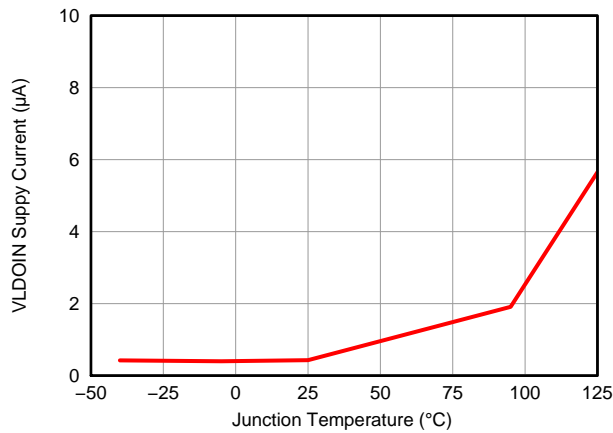

Figure 3. VLDOIN Supply Current vs Junction Temperature

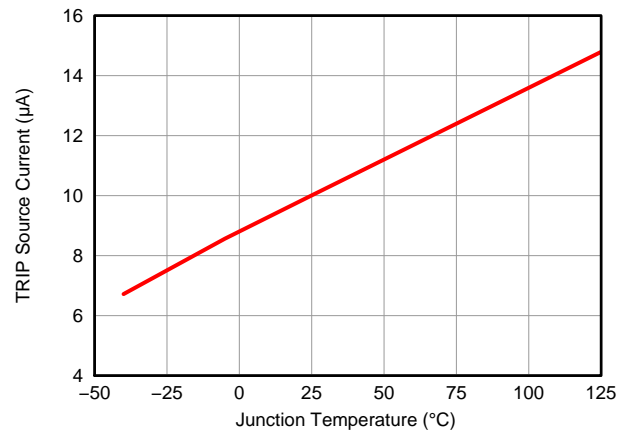

Figure 4. Current Sense Current vs Junction Temperature

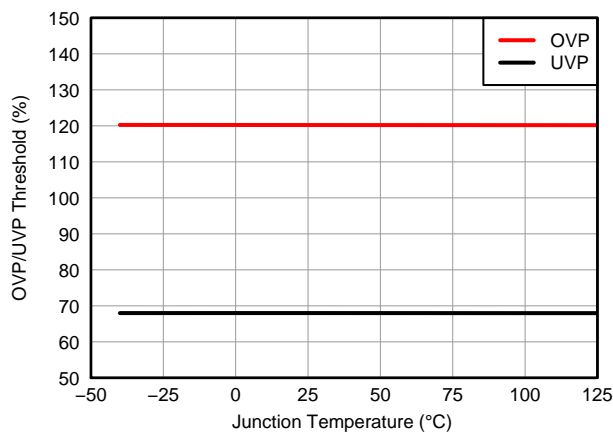

Figure 5. OVP/UVP Threshold vs Junction Temperature

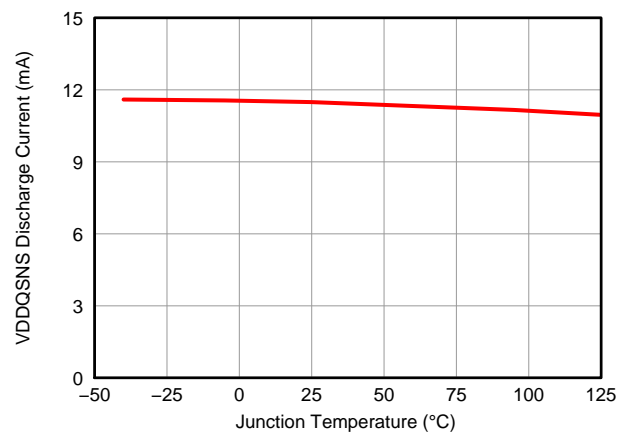

Figure 6. VDDQSNS Discharge Current vs Junction Temperature

TYPICAL CHARACTERISTICS (continued)

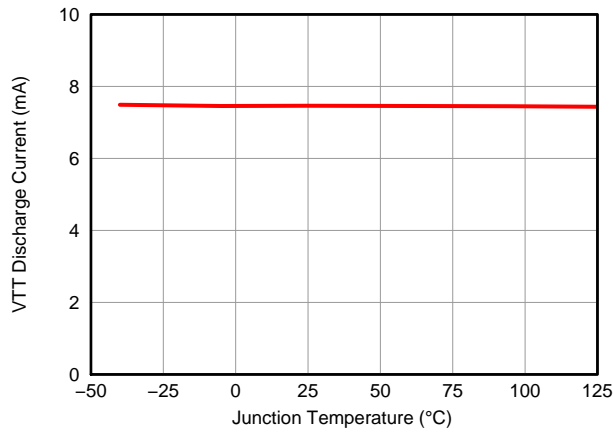

Figure 7. VTT Discharge Current vs Junction Temperature

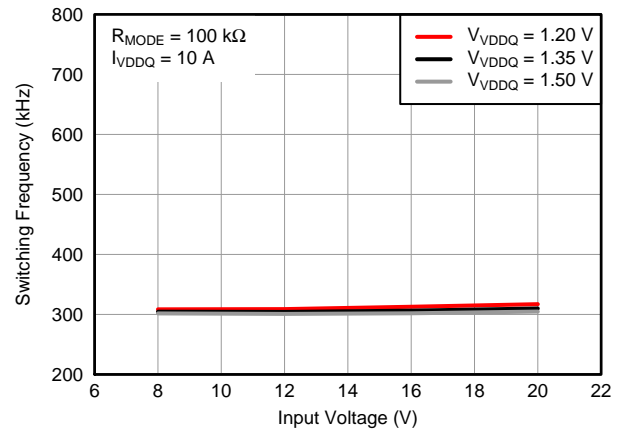

Figure 8. Switching Frequency vs Input Voltage

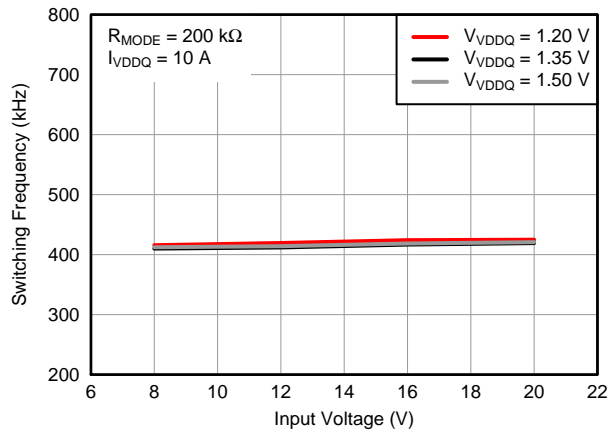

Figure 9. Switching Frequency vs Input Voltage

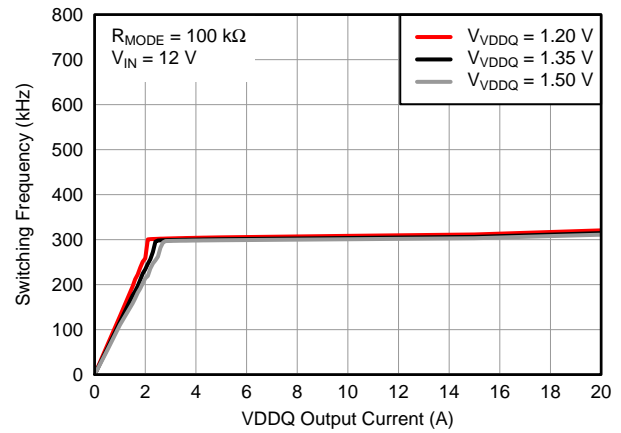

Figure 10. Switching Frequency vs Load Current

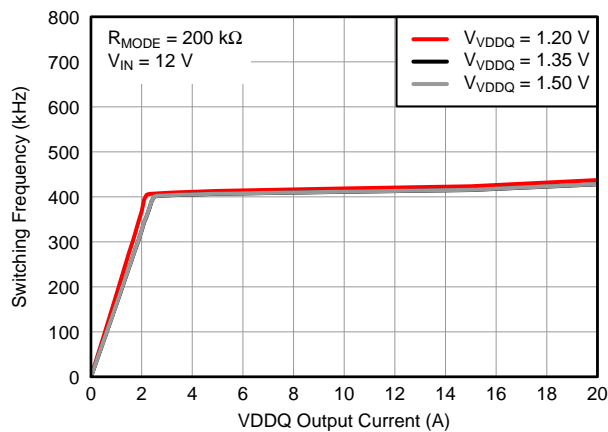

Figure 11. Switching Frequency vs Load Current

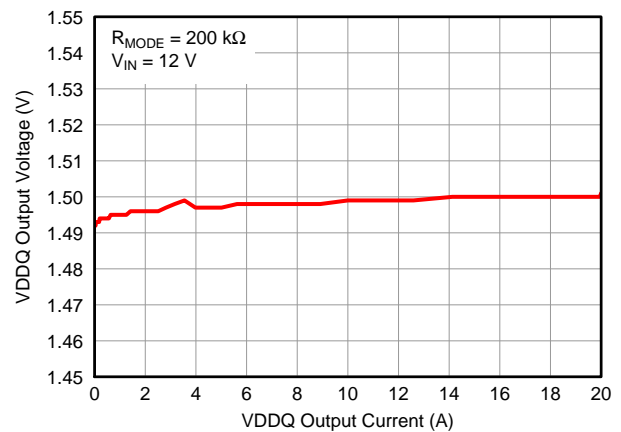

Figure 12. Load Regulation

TYPICAL CHARACTERISTICS (continued)

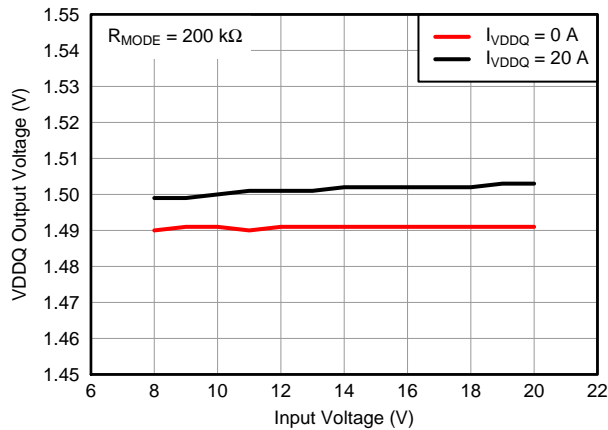

Figure 13. Line Regulation

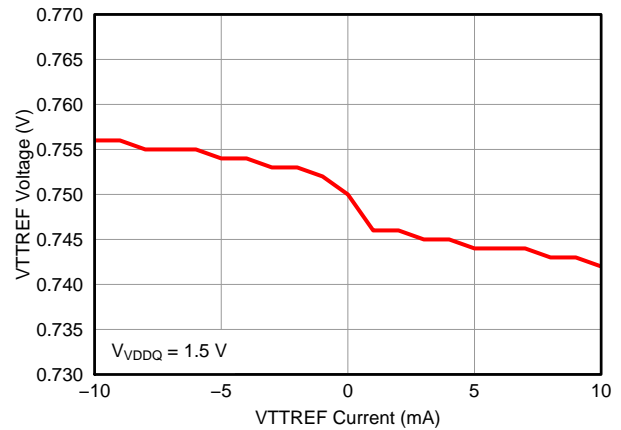

Figure 14. VTTREF Load Regulation

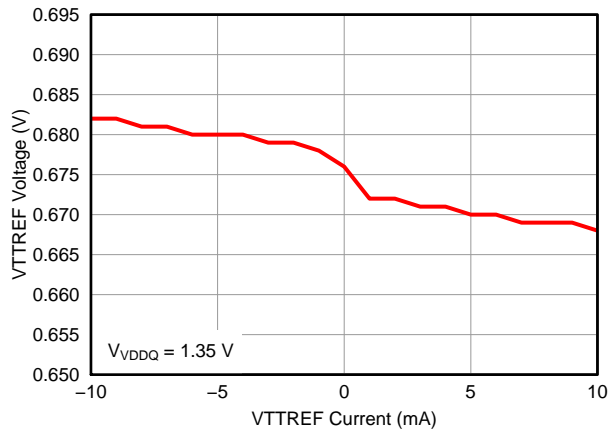

Figure 15. VTTREF Load Regulation

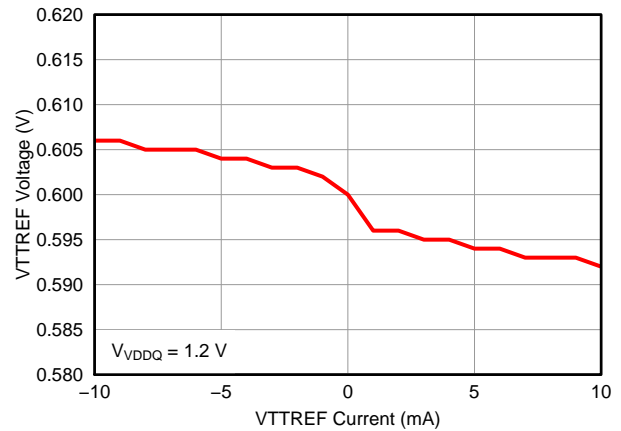

Figure 16. VTTREF Load Regulation

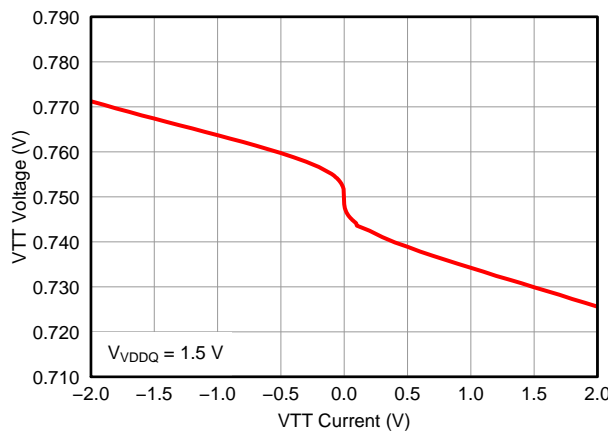

Figure 17. VTT Load Regulation

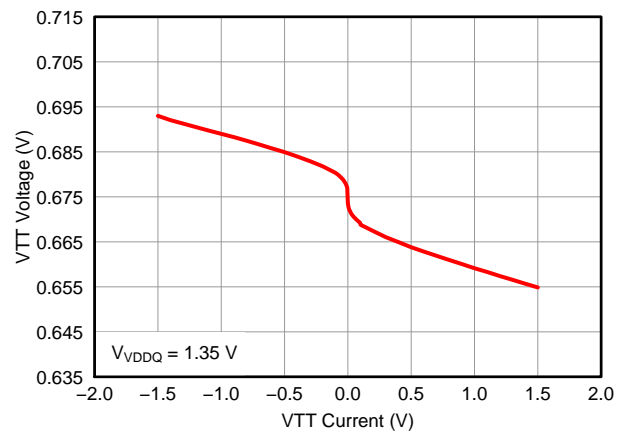

Figure 18. VTT Load Regulation

TYPICAL CHARACTERISTICS (continued)

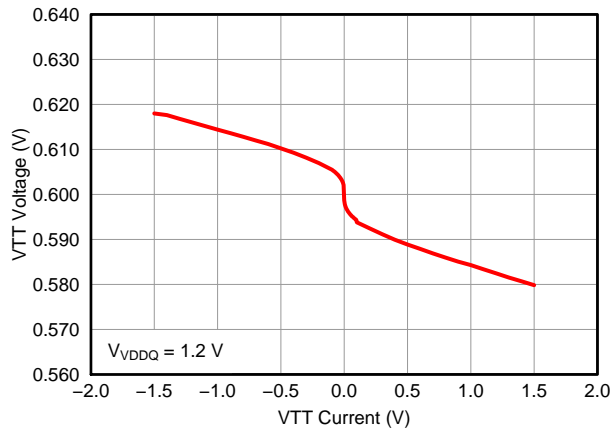

Figure 19. VTT Load Regulation

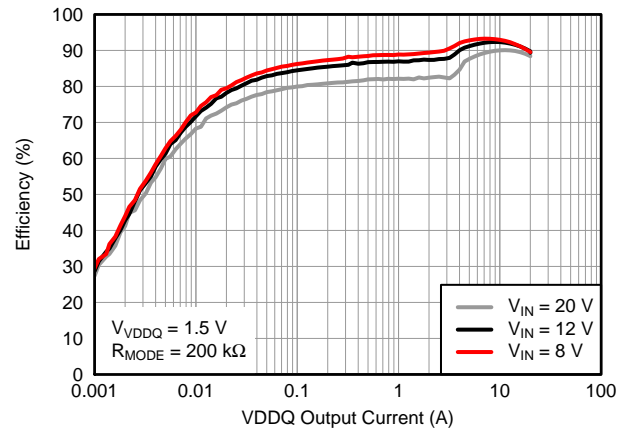

Figure 20. Efficiency

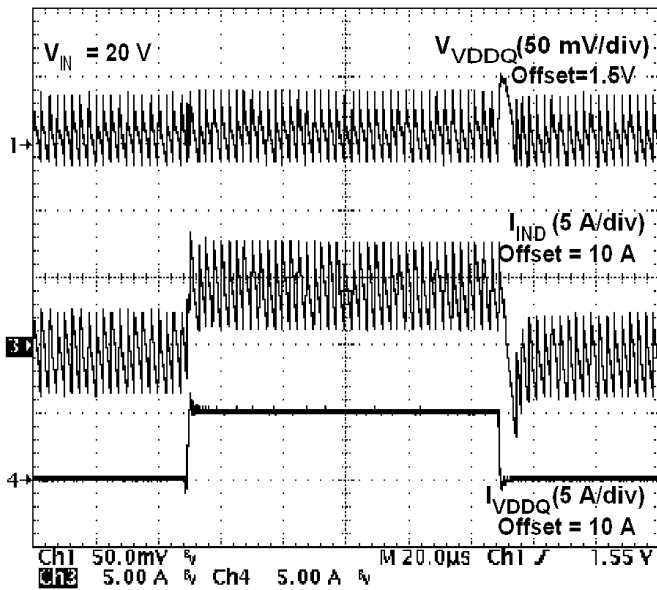

Figure 21. 1.5-V Load Transient Response

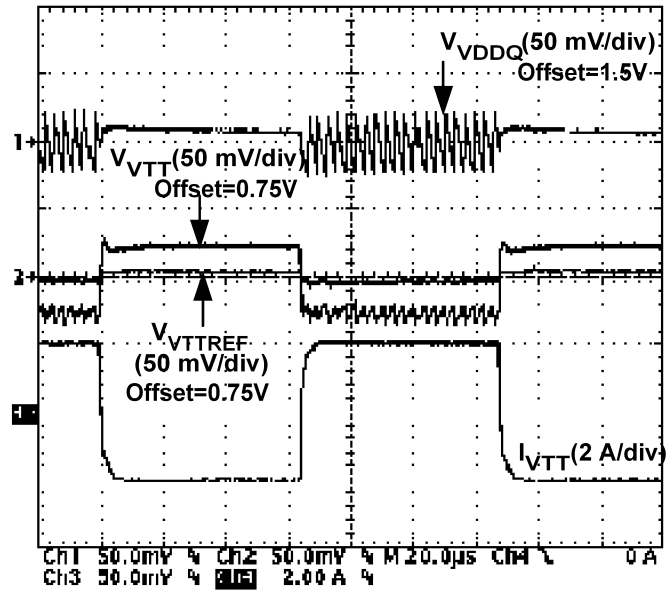

Figure 22. VTT Load Transient Response

TYPICAL CHARACTERISTICS (continued)

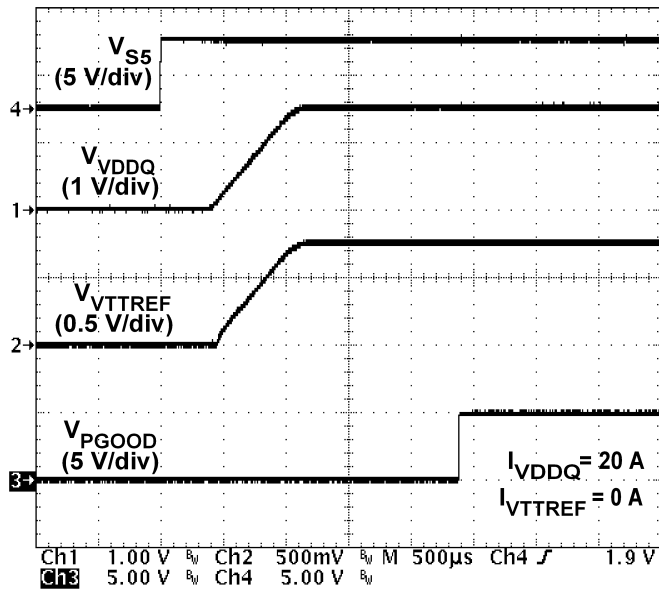

Figure 23. 1.5-V Startup Waveforms

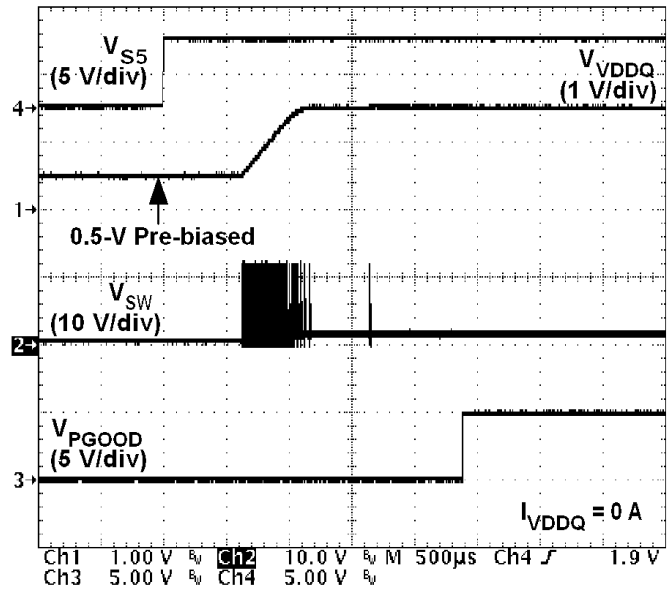

Figure 24. 1.5-V Startup Waveforms (0.5-V Pre-Biased)

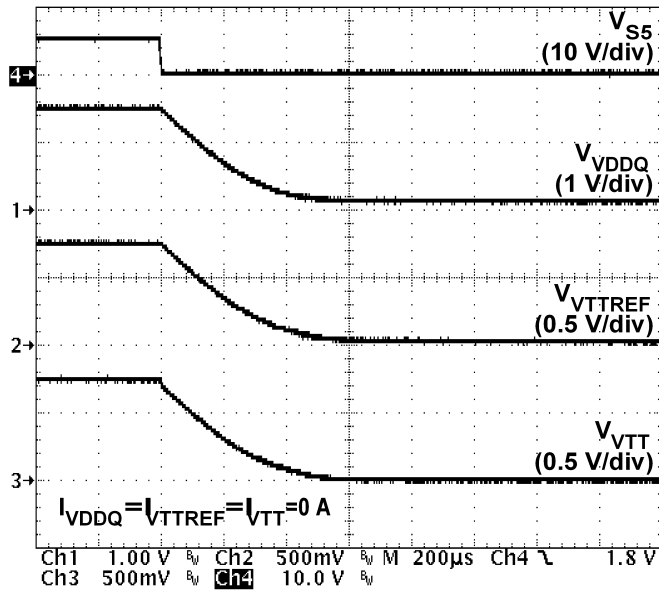

Figure 25. 1.5-V Soft-Stop Waveforms (Tracking Discharge)

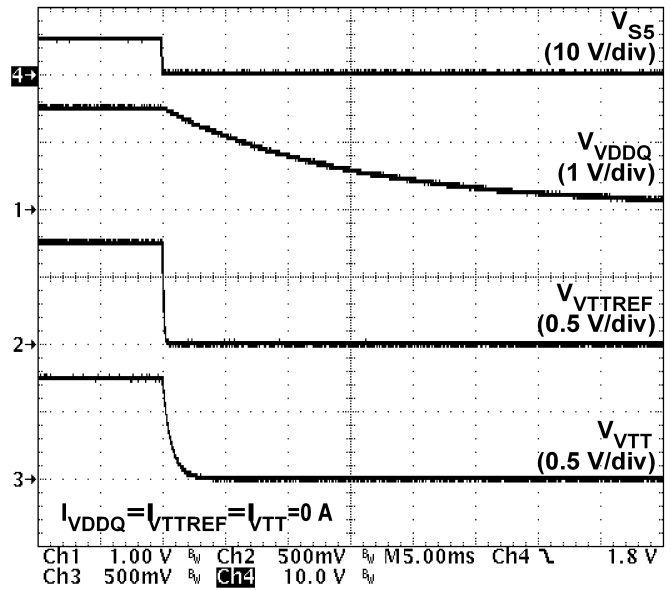

Figure 26. 1.5-V Soft-Stop Waveforms (Non-Tracking Discharge)

TYPICAL CHARACTERISTICS (continued)

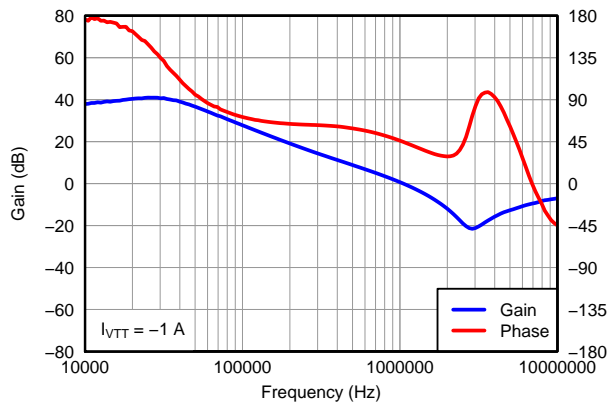

Figure 27. VTT Bode Plot (Sink)

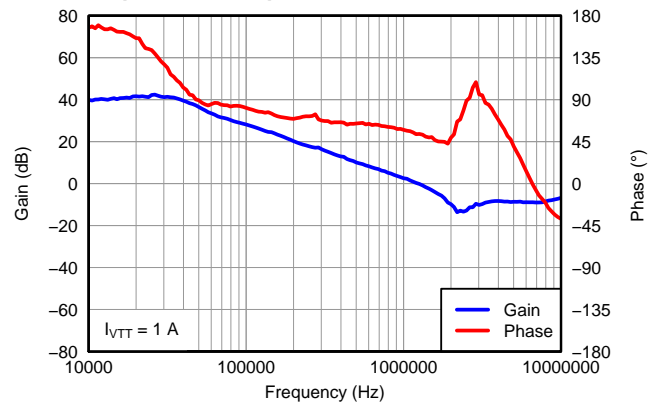

Figure 28. VTT Bode Plot (Source)

APPLICATION INFORMATION

VDDQ Switch Mode Power Supply Control

TPS51216 supports D-CAP™ mode which does not require complex external compensation networks and is suitable for designs with small external components counts. The D-CAP™ mode provides fast transient response with appropriate amount of equivalent series resistance (ESR) on the output capacitors. An adaptive on-time control scheme is used to achieve pseudo-constant frequency. The TPS51216 adjusts the on-time (t_{ON}) to be inversely proportional to the input voltage (V_{IN}) and proportional to the output voltage (V_{DDQ}). This makes a switching frequency fairly constant over the variation of input voltage at the steady state condition.

VREF and REFIN, VDDQ Output Voltage

The part provides a 1.8-V, $\pm 0.8\%$ accurate, voltage reference from VREF. This output has a 300- μ A (max) current capability to drive the REFIN input voltage through a voltage divider circuit. A capacitor with a value of 0.1- μ F or larger should be attached close to the VREF terminal.

The VDDQ switch-mode power supply (SMPS) output voltage is defined by REFIN voltage, within the range between 0.7 V and 1.8 V, programmed by the resistor-divider connected between VREF and GND. (See [External Components Selection](#) section.) A few nano farads of capacitance from REFIN to GND is recommended for stable operation.

Soft-Start and Powergood

TPS51216 provides integrated VDDQ soft-start functions to suppress in-rush current at start-up. The soft-start is achieved by controlling internal reference voltage ramping up. [Figure 29](#) shows the start-up waveforms. The switching regulator waits for 400 μ s after S5 assertion. The MODE pin voltage is read in this period. A typical VDDQ ramp up duration is 700 μ s.

TPS51216 has a powergood open-drain output that indicates the VDDQ voltage is within the target range. The target voltage window and transition delay times of the PGOOD comparator are $\pm 8\%$ (typ) and 1-ms delay for assertion (low to high), and $\pm 16\%$ (typ) and 330-ns delay for de-assertion (high to low) during running. The PGOOD comparator is enabled 1.1 ms after VREF is raised high and the start-up delay is 2.5 ms. Note that the time constant which is composed of the REFIN capacitor and a resistor divider needs to be short enough to reach the target value before PGOOD comparator enabled.

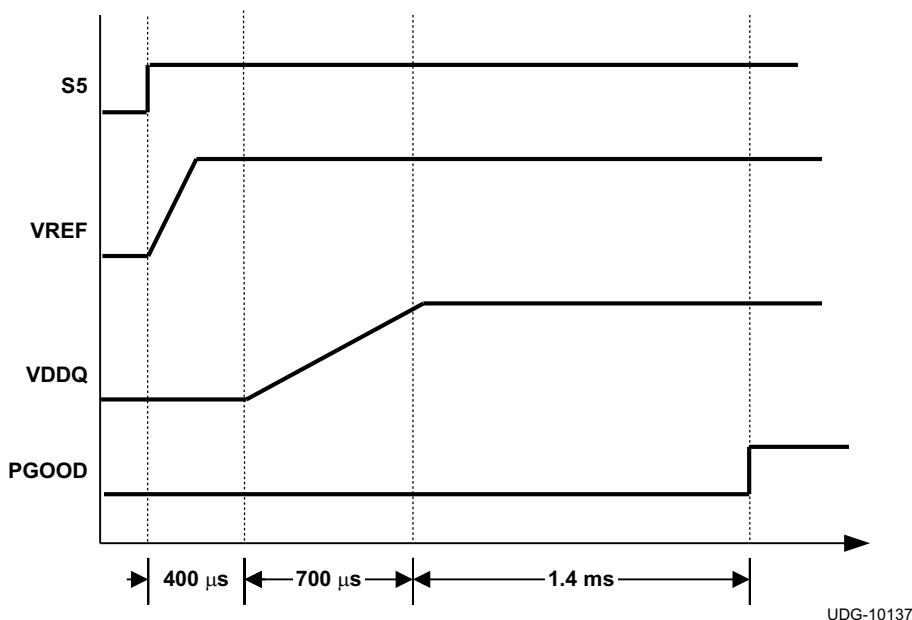

Figure 29. Typical Start-up Waveforms

TPS51216

SLUSAB9A –NOVEMBER 2010–REVISED APRIL 2013

www.ti.com

Power State Control

The TPS51216 has two input pins, S3 and S5, to provide simple control scheme of power state. All of VDDQ, VTTREF and VTT are turned on at S0 state (S3=S5=high). In S3 state (S3=low, S5=high), VDDQ and VTTREF voltages are kept on while VTT is turned off and left at high impedance state (high-Z). The VTT output floats and does not sink or source current in this state. In S4/S5 states (S3=S5=low), all of the three outputs are turned off and discharged to GND according to the discharge mode selected by MODE pin. Each state code represents as follow; S0 = full ON, S3 = suspend to RAM (STR), S4 = suspend to disk (STD), S5 = soft OFF. (See [Table 1](#))

Table 1. S3/S5 Power State Control

STATE	S3	S5	VREF	VDDQ	VTTREF	VTT
S0	HI	HI	ON	ON	ON	ON
S3	LO	HI	ON	ON	ON	OFF(High-Z)
S4/S5	LO	LO	OFF	OFF(Discharge)	OFF(Discharge)	OFF(Discharge)

MODE Pin Configuration

The TPS51216 reads the MODE pin voltage when the S5 signal is raised high and stores the status in a register. A 15- μ A current is sourced from the MODE pin during this time to read the voltage across the resistor connected between the pin and GND. [Table 2](#) shows resistor values, corresponding switching frequency and discharge mode configurations.

Table 2. MODE Selection

MODE NO.	RESISTANCE BETWEEN MODE AND GND (k Ω)	SWITCHING FREQUENCY (kHz)	DISCHARGE MODE
3	200	400	Tracking
2	100	300	
1	68	300	Non-tracking
0	47	400	

Discharge Control

In S4/S5 state, VDDQ, VTT, and VTTREF outputs are discharged based on the respective discharge mode selected above. The tracking discharge mode discharges VDDQ output through the internal VTT regulator transistors enabling quick discharge operation. The VTT output maintains tracking of the VTTREF voltage in this mode. (Please refer to [Figure 25](#)) After 4 ms of tracking discharge operation, the mode changes to non-tracking discharge. The VDDQ output must be connected to the VLDOIN pin in this mode. The non-tracking mode discharges the VDDQ and VTT pins using internal MOSFETs that are connected to corresponding output terminals. The non-tracking discharge is slow compared with the tracking discharge due to the lower current capability of these MOSFETs. (Please refer to [Figure 26](#))

D-CAP™ Mode

Figure 30 shows a simplified model of D-CAP™ mode architecture.

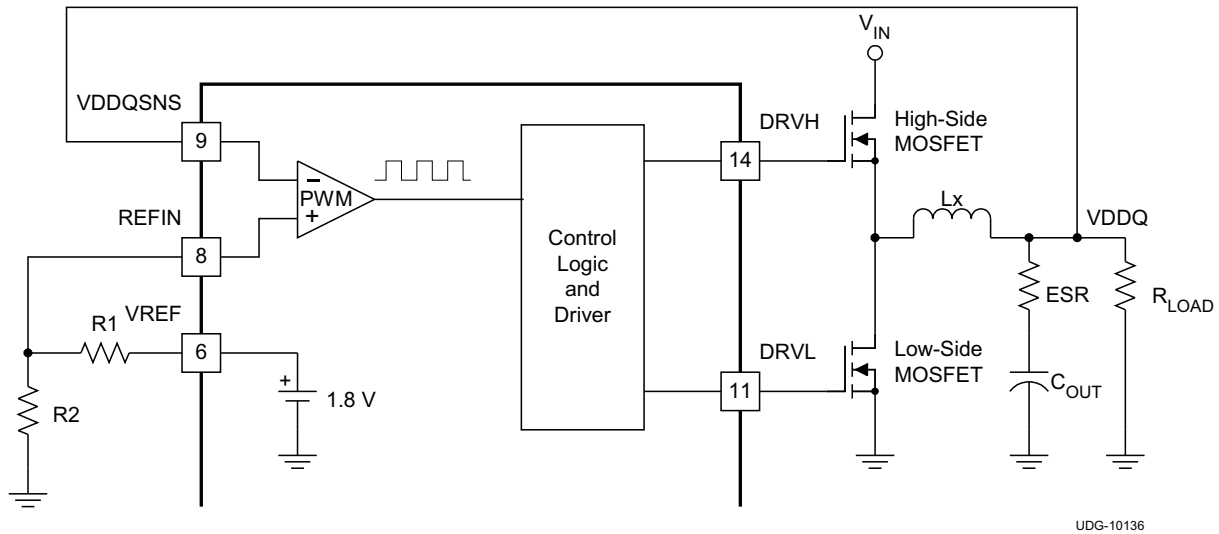

Figure 30. Simplified D-CAP™ Model

The VDDQSNS voltage is compared with REFIN voltage. The PWM comparator creates a set signal to turn on the high-side MOSFET. The gain and speed of the comparator is high enough to maintain the voltage at the beginning of each on-cycle (or the end of each off-cycle) to be substantially constant. The DC output voltage monitored at VDDQ may have line regulation due to ripple amplitude that slightly increases as the input voltage increase. The D-CAP™ mode offers flexibility on output inductance and capacitance selections and provides ease-of-use with a low external component count. However, it requires a sufficient amount of output ripple voltage for stable operation and good jitter performance.

The requirement for loop stability is simple and is described in Equation 1. The 0-dB frequency, f_0 defined in Equation 1, is recommended to be lower than 1/3 of the switching frequency to secure proper phase margin.

$$f_0 = \frac{1}{2\pi \times \text{ESR} \times C_{\text{OUT}}} \leq \frac{f_{\text{SW}}}{3}$$

where

- ESR is the effective series resistance of the output capacitor
- C_{OUT} is the capacitance of the output capacitor
- f_{sw} is switching frequency

(1)

Jitter is another attribute caused by signal-to-noise ratio of the feedback signal. One of the major factors that determine jitter performance in D-CAP™ mode is the down-slope angle of the VDDQSNS ripple voltage. Figure 31 shows, in the same noise condition, a jitter is improved by making the slope angle larger.

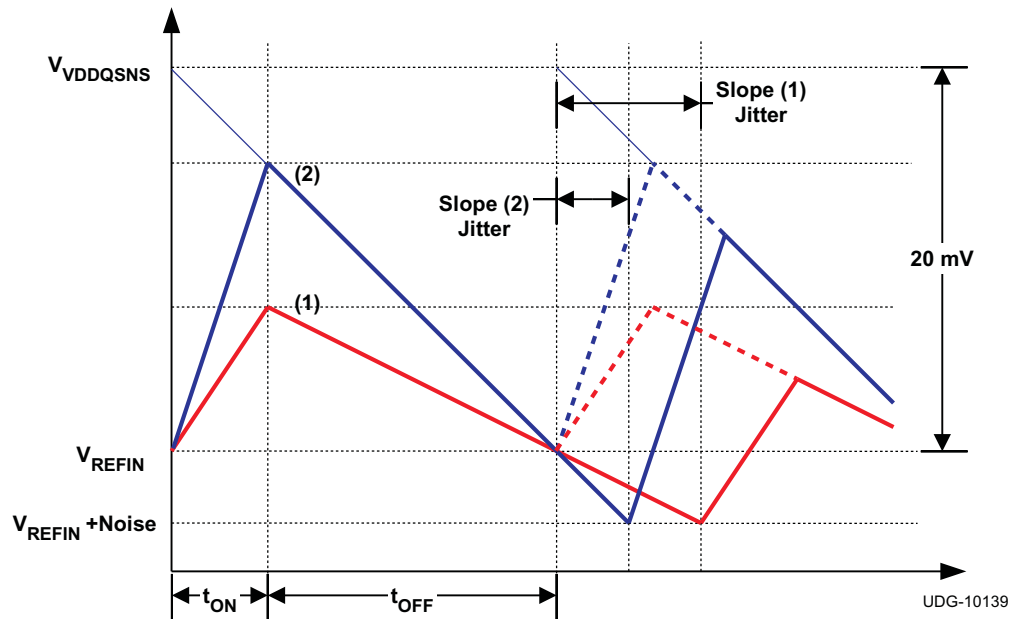

Figure 31. Ripple Voltage Slope and Jitter Performance

For a good jitter performance, use the recommended down slope of approximately 20 mV per switching period as shown in [Figure 31](#) and [Equation 2](#).

$$\frac{V_{OUT} \times ESR}{f_{SW} \times L_X} \geq 20\text{mV}$$

where

- V_{OUT} is the VDDQ output voltage
- L_X is the inductance

(2)

Light-Load Operation

In auto-skip mode, the TPS51216 SMPS control logic automatically reduces its switching frequency to improve light-load efficiency. To achieve this intelligence, a zero cross detection comparator is used to prevent negative inductor current by turning off the low-side MOSFET. [Equation 3](#) shows the boundary load condition of this skip mode and continuous conduction operation.

$$I_{LOAD(LL)} = \frac{(V_{IN} - V_{OUT})}{2 \times L_X} \times \frac{V_{OUT}}{V_{IN}} \times \frac{1}{f_{SW}}$$

(3)

VTT and VTTREF

TPS51216 integrates two high performance, low-drop-out linear regulators, VTT and VTTREF, to provide complete DDR2/DDR3/DDR3L power solutions. The VTTREF has a 10-mA sink/source current capability, and tracks $\frac{1}{2}$ of VDDQSNS with $\pm 1\%$ accuracy using an on-chip $\frac{1}{2}$ divider. A 0.22- μF (or larger) ceramic capacitor must be connected close to the VTTREF terminal for stable operation. The VTT responds quickly to track VTTREF within ± 40 mV at all conditions, and the current capability is 2 A for both sink and source. A 10- μF (or larger) ceramic capacitor(s) need to be connected close to the VTT terminal for stable operation. To achieve tight regulation with minimum effect of wiring resistance, a remote sensing terminal, VTTSNS, should be connected to the positive node of VTT output capacitor(s) as a separate trace from the high-current line to the VTT pin. (Please refer to the [Layout Considerations](#) section for details.)

When VTT is not required in the design, the following treatments are strongly recommended.

- Connect VLDOIN to VDDQ.
- Tie VTTSNS to VTT, and remove capacitors from VTT to float.
- Connect VTTGND to GND.
- Select MODE 0 or MODE 1 shown in [Table 2](#) (Select Non-tracking discharge mode).
- Maintain a 0.22- μF capacitor connected at VTTREF.
- Pull-down S3 to GND with 1-k Ω resistance.

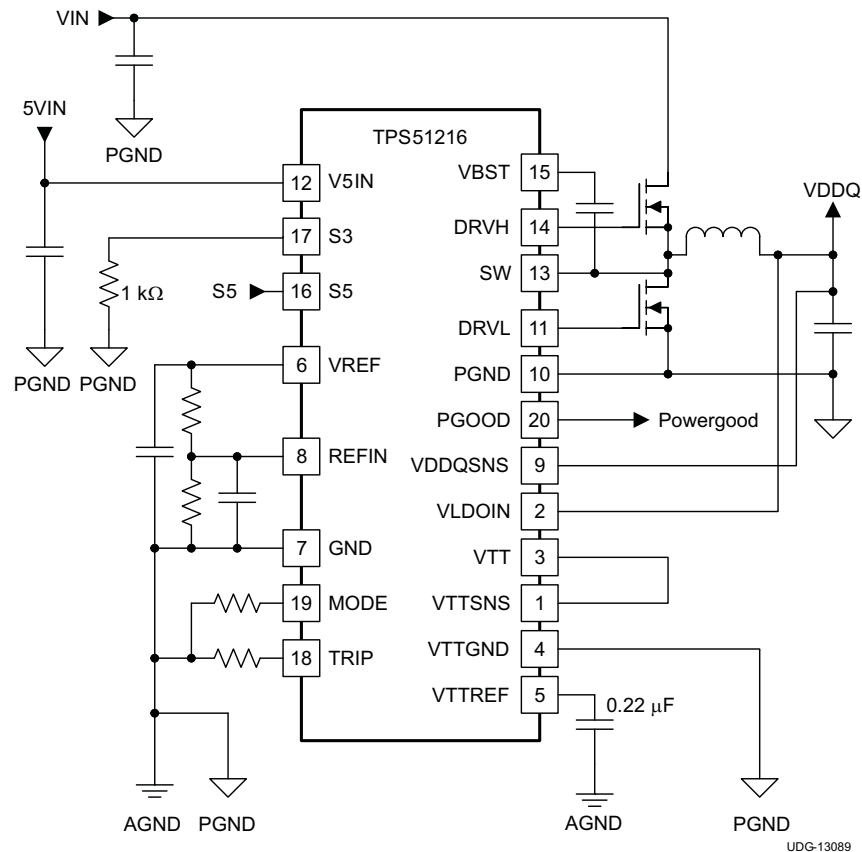

Figure 32. Application Circuit When VTT Is Not Required

VDDQ Overvoltage and Undervoltage Protection

TPS51216 sets the overvoltage protection (OVP) when the VDDQSNS voltage reaches a level 20% (typ) higher than the REFIN voltage. When an OV event is detected, the controller latches DRVH low and DRVL high. VTTREF and VTT are turned off and discharged using the non-tracking discharge MOSFETs regardless of the tracking mode.

The undervoltage protection (UVP) latch is set when the VDDQSNS voltage remains lower than 68% (typ) of the REFIN voltage for 1 ms or longer. In this fault condition, the controller latches DRVH low and DRVL low and discharges the VDDQ, VTT and VTTREF outputs. UVP detection function is enabled after 1.2 ms of SMPS operation to ensure startup.

To release the OVP and UVP latches, toggle S5 or adjust the V5IN voltage down and up beyond the undervoltage lockout threshold.

VDDQ Overcurrent Protection

The VDDQ SMPS has cycle-by-cycle overcurrent limiting protection. The inductor current is monitored during the off-state using the low-side MOSFET $R_{DS(on)}$ and the controller maintains the off-state while the voltage across the low-side MOSFET is larger than the overcurrent trip level. The current monitor circuit inputs are PGND and SW pins so that those should be properly connected to the source and drain terminals of low-side MOSFET. The overcurrent trip level, V_{TRIP} , is determined by Equation 4, where R_{TRIP} is the value of the resistor connected between the TRIP pin and GND, and I_{TRIP} is the current sourced from the TRIP pin. I_{TRIP} is 10 μ A typically at room temperature, and has 4700ppm/ $^{\circ}$ C temperature coefficient to compensate the temperature dependency of the low-side MOSFET $R_{DS(on)}$.

$$V_{TRIP} = R_{TRIP} \times I_{TRIP} \quad (4)$$

Because the comparison is done during the off-state, V_{TRIP} sets the valley level of the inductor current. The load current OCL level, I_{OCL} , can be calculated by considering the inductor ripple current as shown in Equation 5

$$I_{OCL} = \left(\frac{V_{TRIP}}{8 \times R_{DS(on)}} \right) + \frac{I_{IND(ripple)}}{2} = \left(\frac{V_{TRIP}}{8 \times R_{DS(on)}} \right) + \frac{1}{2} \times \frac{V_{IN} - V_{OUT}}{L_X} \times \frac{V_{OUT}}{f_{SW} \times V_{IN}}$$

where

- $I_{IND(ripple)}$ is inductor ripple current (5)

In an overcurrent condition, the current to the load exceeds the current to the output capacitor, thus the output voltage tends to fall down. Eventually, it crosses the undervoltage protection threshold and shuts down.

VTT Overcurrent Protection

The LDO has an internally fixed constant overcurrent limiting of 3-A (typ) for both sink and source operation.

V5IN Undervoltage Lockout Protection

TPS51216 has a 5-V supply undervoltage lockout protection (UVLO) threshold. When the V5IN voltage is lower than UVLO threshold voltage, typically 3.93 V, VDDQ, VTT and VTTREF are shut off. This is a non-latch protection.

Thermal Shutdown

TPS51216 includes an internal temperature monitor. If the temperature exceeds the threshold value, 140 $^{\circ}$ C (typ), VDDQ, VTT and VTTREF are shut off. The thermal shutdown state of VDDQ is open, VTT and VTTREF are high impedance (high-Z) respectively, and the discharge functions are disabled. This is a non-latch protection and the operation is restarted with soft-start sequence when the device temperature is reduced by 10 $^{\circ}$ C (typ).

External Components Selection

The external components selection is simple in D-CAP™ mode.

1. DETERMINE THE VALUE OF R1 AND R2

The output voltage is determined by the value of the voltage-divider resistor, R1 and R2 as shown in [Figure 30](#). R1 is connected between VREF and REFIN pins, and R2 is connected between the REFIN pin and GND. Setting R1 as 10-kΩ is a good starting point. Determine R2 using [Equation 6](#).

$$R2 = \frac{R1}{\left(\frac{1.8}{V_{OUT} - \left(\frac{I_{IND(ripple)} \times ESR}{2} \right)} \right) - 1} \quad (6)$$

2. CHOOSE THE INDUCTOR

The inductance value should be determined to yield a ripple current of approximately ¼ to ½ of maximum output current. Larger ripple current increases output ripple voltage and improves the signal-to-noise ratio and helps stable operation.

$$L_X = \frac{1}{I_{IND(ripple)} \times f_{SW}} \times \frac{(V_{IN(max)} - V_{OUT}) \times V_{OUT}}{V_{IN(max)}} = \frac{3}{I_{O(max)} \times f_{SW}} \times \frac{(V_{IN(max)} - V_{OUT}) \times V_{OUT}}{V_{IN(max)}} \quad (7)$$

The inductor needs a low direct current resistance (DCR) to achieve good efficiency, as well as enough room above peak inductor current before saturation. The peak inductor current can be estimated in [Equation 8](#).

$$I_{IND(peak)} = \frac{V_{TRIP}}{8 \times R_{DS(on)}} + \frac{1}{L_X \times f_{SW}} \times \frac{(V_{IN(max)} - V_{OUT}) \times V_{OUT}}{V_{IN(max)}} \quad (8)$$

3. CHOOSE THE OCL SETTING RESISTANCE, R_{TRIP}

Combining [Equation 4](#) and [Equation 5](#), R_{TRIP} can be obtained using [Equation 9](#).

$$R_{TRIP} = \frac{8 \times \left(I_{OCL} - \left(\frac{(V_{IN} - V_{OUT})}{(2 \times L_X)} \right) \times \frac{V_{OUT}}{(f_{SW} \times V_{IN})} \right) \times R_{DS(on)}}{I_{TRIP}} \quad (9)$$

4. CHOOSE THE OUTPUT CAPACITORS

Organic semiconductor capacitor(s) or specialty polymer capacitor(s) are recommended. Determine ESR to meet small signal stability and recommended ripple voltage. A quick reference is shown in [Equation 10](#) and [Equation 11](#).

$$\frac{1}{2\pi \times ESR \times C_{OUT}} \leq \frac{f_{SW}}{3} \quad (10)$$

$$\frac{V_{OUT} \times ESR}{f_{SW} \times L_X} \geq 20\text{mV} \quad (11)$$

TPS51216

SLUSAB9A –NOVEMBER 2010–REVISED APRIL 2013

www.ti.com

TPS51216 Application Circuit

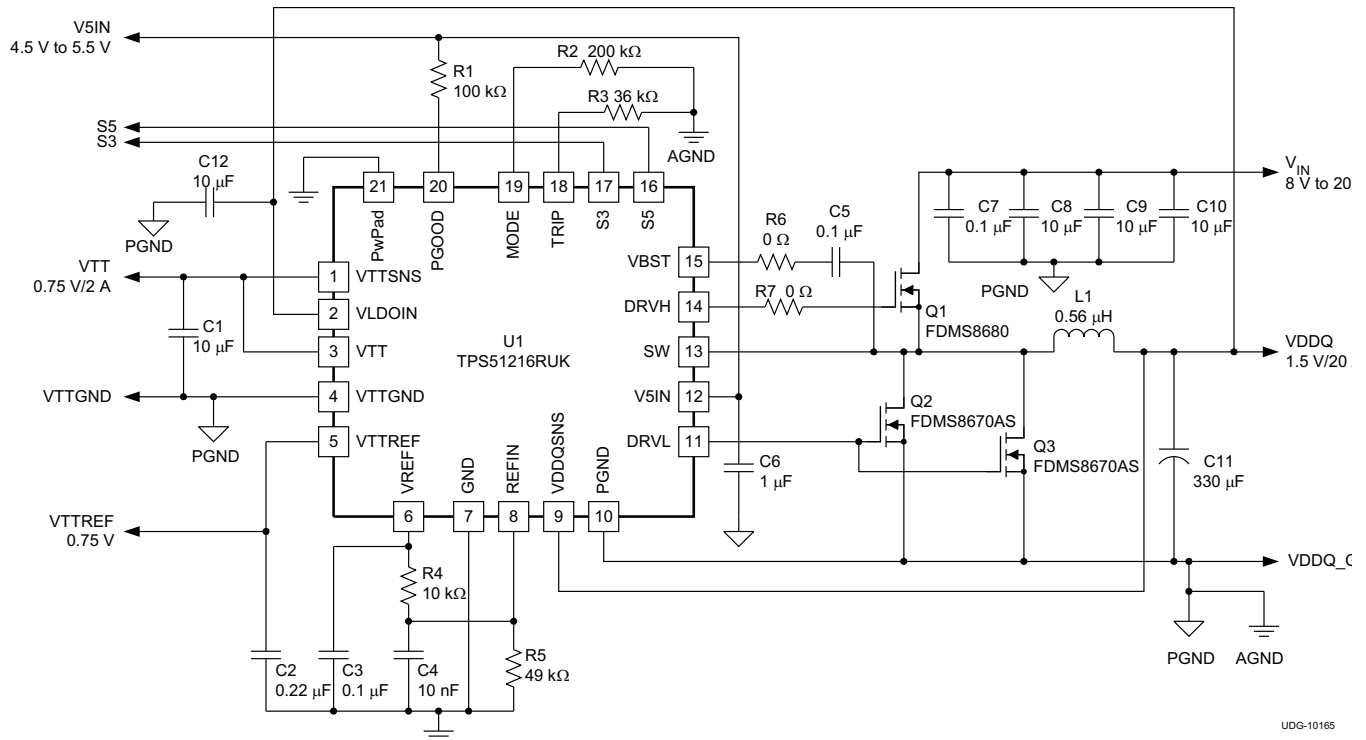

Figure 33. DDR3, 400-kHz Application Circuit, Tracking Discharge

Table 3. DDR3, 400-kHz Application Circuit, List of Materials

REFERENCE DESIGNATOR	QTY	SPECIFICATION	MANUFACTURE	PART NUMBER
C8, C9, C10	3	10 µF, 25 V	Taiyo Yuden	TMK325BJ106MM
C11	1	330 µF, 2V, 6 mΩ	Panasonic	EEFSX0D331XE
L1	1	0.56 µH, 21 A, 1.56 mΩ	Panasonic	ETQP4LR56WFC
Q1	1	30 V, 35 A, 8.5 mΩ	Fairchild	FDMS8680
Q2, Q3	2	30 V, 42 A, 3.5 mΩ	Fairchild	FDMS8670AS

For this example, the bulk output capacitor ESR requirement for D-CAP™ mode is described in Equation 12, whichever is greater.

$$ESR \geq \frac{20\text{mV} \times f_{\text{SW}} \times L}{V_{\text{OUT}}} \quad \text{or} \quad ESR \geq \frac{3}{2\pi \times f_{\text{SW}} \times C_{\text{OUT}}} \quad (12)$$

Layout Considerations

Certain issues must be considered before designing a layout using the TPS51216.

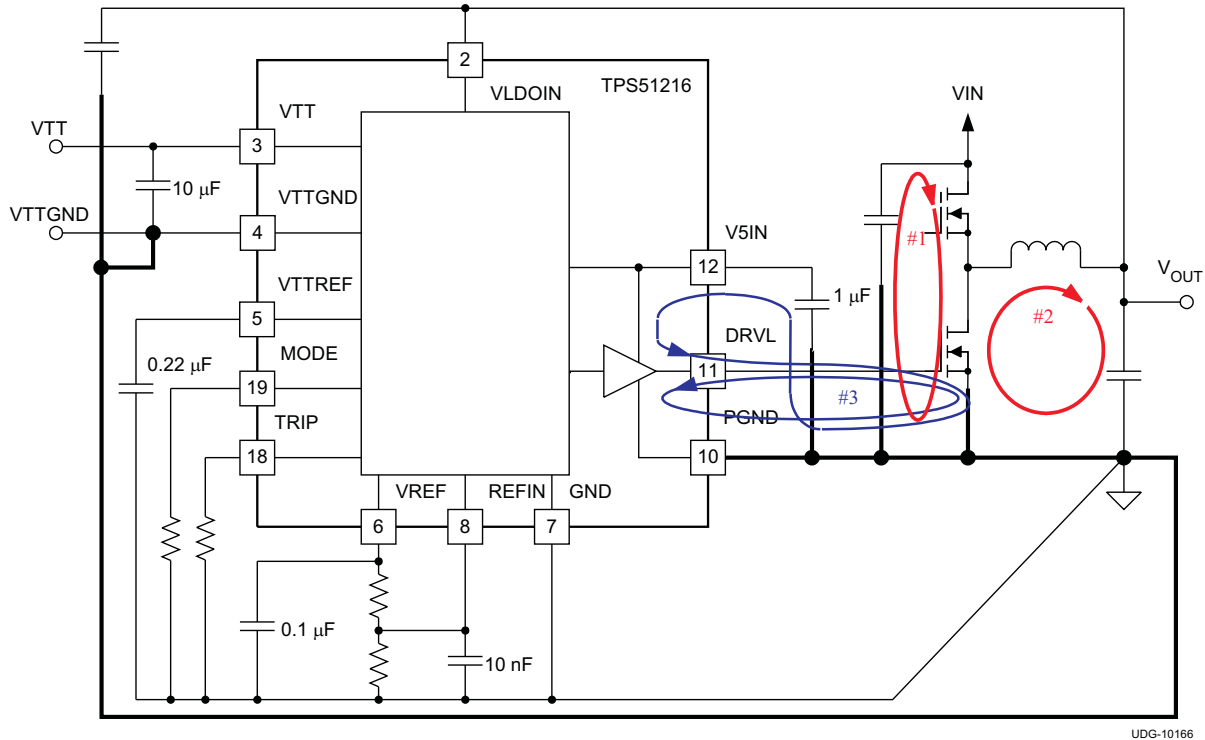

Figure 34. DC/DC Converter Ground System

- VIN capacitor(s), VOUT capacitor(s) and MOSFETs are the power components and should be placed on one side of the PCB (solder side). Other small signal components should be placed on another side (component side). At least one inner plane should be inserted, connected to ground, in order to shield and isolate the small signal traces from noisy power lines.
- All sensitive analog traces and components such as VDDQSNS, VTTSNS, MODE, REFIN, VREF and TRIP should be placed away from high-voltage switching nodes such as SW, DRVL, DRVH or VBST to avoid coupling. Use internal layer(s) as ground plane(s) and shield feedback trace from power traces and components.
- The DC/DC converter has several high-current loops. The area of these loops should be minimized in order to suppress generating switching noise.
 - The most important loop to minimize the area of is the path from the VIN capacitor(s) through the high and low-side MOSFETs, and back to the capacitor(s) through ground. Connect the negative node of the VIN capacitor(s) and the source of the low-side MOSFET at ground as close as possible. (Refer to loop #1 of Figure 34)
 - The second important loop is the path from the low-side MOSFET through inductor and VOUT capacitor(s), and back to source of the low-side MOSFET through ground. Connect source of the low-side MOSFET and negative node of VOUT capacitor(s) at ground as close as possible. (Refer to loop #2 of Figure 34)
 - The third important loop is of gate driving system for the low-side MOSFET. To turn on the low-side MOSFET, high current flows from V5IN capacitor through gate driver and the low-side MOSFET, and back to negative node of the capacitor through ground. To turn off the low-side MOSFET, high current flows from gate of the low-side MOSFET through the gate driver and PGND, and back to source of the low-side MOSFET through ground. Connect negative node of V5IN capacitor, source of the low-side MOSFET and PGND at ground as close as possible. (Refer to loop #3 of Figure 34)
- Because the TPS51216 controls output voltage referring to voltage across VOUT capacitor, VDDQSNS should be connected to the positive node of VOUT capacitor. In a same manner GND should be connected to the negative node of VOUT capacitor.

TPS51216

SLUSAB9A –NOVEMBER 2010–REVISED APRIL 2013

www.ti.com

- Connect the overcurrent setting resistors from TRIP pin to ground and make the connections as close as possible to the device. The trace from TRIP pin to resistor and from resistor to ground should avoid coupling to a high-voltage switching node.
- Connect the frequency and mode setting resistor from MODE pin to ground, and make the connections as close as possible to the device. The trace from the MODE pin to the resistor and from the resistor to ground should avoid coupling to a high-voltage switching node
- Connections from gate drivers to the respective gate of the high-side or the low-side MOSFET should be as short as possible to reduce stray inductance. Use 0.65 mm (25 mils) or wider trace and via(s) of at least 0.5 mm (20 mils) diameter along this trace.
- The PCB trace defined as SW node, which connects to the source of the switching MOSFET, the drain of the rectifying MOSFET and the high-voltage side of the inductor, should be as short and wide as possible.
- VLDOIN should be connected to VDDQ output with short and wide traces. An input bypass capacitor should be placed as close as possible to the pin with short and wide connections.
- The output capacitor for VTT should be placed close to the pin with a short and wide connection in order to avoid additional ESR and/or ESL of the trace.
- VTTSNS should be connected to the positive node of the VTT output capacitor(s) as a separate trace from the high-current power line and is strongly recommended to avoid additional ESR and/or ESL. If it is needed to sense the voltage at the point of the load, it is recommended to attach the output capacitor(s) at that point. Also, it is recommended to minimize any additional ESR and/or ESL of ground trace between GND pin and the output capacitor(s).
- Consider adding a low pass filter (LPF) at VTTSNS in case the ESR of the VTT output capacitor(s) is larger than 2 mΩ.
- VDDQSNS can be connected separately from VLDOIN. Remember that this sensing potential is the reference voltage of VTTREF. Avoid any noise generative lines.
- The negative node of the VTT output capacitor(s) and the VTTREF capacitor should be tied together by avoiding common impedance to high-current path of the VTT source/sink current.
- GND pin node represents the reference potential for VTTREF and VTT outputs. Connect GND to negative nodes of VTT capacitor(s), VTTREF capacitor and VDDQ capacitor(s) with care to avoid additional ESR and/or ESL. GND and PGND should be connected together at a single point.
- In order to effectively remove heat from the package, prepare the thermal land and solder to the package thermal pad. Wide trace of the component-side copper, connected to this thermal land, helps heat spreading. Numerous vias with a 0.3-mm diameter connected from the thermal land to the internal/solder-side ground plane(s) should be used to help dissipation.

CAUTION

Do NOT connect PGND pin directly to this thermal land underneath the package.

REVISION HISTORY

Changes from Original (November 2010) to Revision A	Page
• Added specifications to ABSOLUTE MAXIMUM RATINGS table.	2
• Added clarity to VTT and VTTREF section.	19

PACKAGING INFORMATION

Orderable Device	Status (1)	Package Type	Package Drawing	Pins	Package Qty	Eco Plan (2)	Lead/Ball Finish (6)	MSL Peak Temp (3)	Op Temp (°C)	Device Marking (4/5)	Samples
FX004	ACTIVE	WQFN	RUK	20	3000	Green (RoHS & no Sb/Br)	CU NIPDAU	Level-2-260C-1 YEAR	-40 to 85	51216	Samples
TPS51216RUKR	ACTIVE	WQFN	RUK	20	3000	Green (RoHS & no Sb/Br)	CU NIPDAU	Level-2-260C-1 YEAR	-40 to 85	51216	Samples
TPS51216RUKT	ACTIVE	WQFN	RUK	20	250	Green (RoHS & no Sb/Br)	CU NIPDAU	Level-2-260C-1 YEAR	-40 to 85	51216	Samples

(1) The marketing status values are defined as follows:

ACTIVE: Product device recommended for new designs.

LIFEBUY: TI has announced that the device will be discontinued, and a lifetime-buy period is in effect.

NRND: Not recommended for new designs. Device is in production to support existing customers, but TI does not recommend using this part in a new design.

PREVIEW: Device has been announced but is not in production. Samples may or may not be available.

OBsolete: TI has discontinued the production of the device.

(2) **RoHS:** TI defines "RoHS" to mean semiconductor products that are compliant with the current EU RoHS requirements for all 10 RoHS substances, including the requirement that RoHS substance do not exceed 0.1% by weight in homogeneous materials. Where designed to be soldered at high temperatures, "RoHS" products are suitable for use in specified lead-free processes. TI may reference these types of products as "Pb-Free".

RoHS Exempt: TI defines "RoHS Exempt" to mean products that contain lead but are compliant with EU RoHS pursuant to a specific EU RoHS exemption.

Green: TI defines "Green" to mean the content of Chlorine (Cl) and Bromine (Br) based flame retardants meet JS709B low halogen requirements of <=1000ppm threshold. Antimony trioxide based flame retardants must also meet the <=1000ppm threshold requirement.

(3) MSL, Peak Temp. - The Moisture Sensitivity Level rating according to the JEDEC industry standard classifications, and peak solder temperature.

(4) There may be additional marking, which relates to the logo, the lot trace code information, or the environmental category on the device.

(5) Multiple Device Markings will be inside parentheses. Only one Device Marking contained in parentheses and separated by a "~" will appear on a device. If a line is indented then it is a continuation of the previous line and the two combined represent the entire Device Marking for that device.

(6) Lead/Ball Finish - Orderable Devices may have multiple material finish options. Finish options are separated by a vertical ruled line. Lead/Ball Finish values may wrap to two lines if the finish value exceeds the maximum column width.

Important Information and Disclaimer: The information provided on this page represents TI's knowledge and belief as of the date that it is provided. TI bases its knowledge and belief on information provided by third parties, and makes no representation or warranty as to the accuracy of such information. Efforts are underway to better integrate information from third parties. TI has taken and continues to take reasonable steps to provide representative and accurate information but may not have conducted destructive testing or chemical analysis on incoming materials and chemicals. TI and TI suppliers consider certain information to be proprietary, and thus CAS numbers and other limited information may not be available for release.

In no event shall TI's liability arising out of such information exceed the total purchase price of the TI part(s) at issue in this document sold by TI to Customer on an annual basis.

OTHER QUALIFIED VERSIONS OF TPS51216 :

- Enhanced Product: [TPS51216-EP](#)

NOTE: Qualified Version Definitions:

- Enhanced Product - Supports Defense, Aerospace and Medical Applications

TAPE AND REEL INFORMATION

QUADRANT ASSIGNMENTS FOR PIN 1 ORIENTATION IN TAPE

*All dimensions are nominal

Device	Package Type	Package Drawing	Pins	SPQ	Reel Diameter (mm)	Reel Width W1 (mm)	A0 (mm)	B0 (mm)	K0 (mm)	P1 (mm)	W (mm)	Pin1 Quadrant
TPS51216RUKR	WQFN	RUK	20	3000	330.0	12.4	3.3	3.3	1.1	8.0	12.0	Q2
TPS51216RUKT	WQFN	RUK	20	250	180.0	12.5	3.3	3.3	1.1	8.0	12.0	Q2

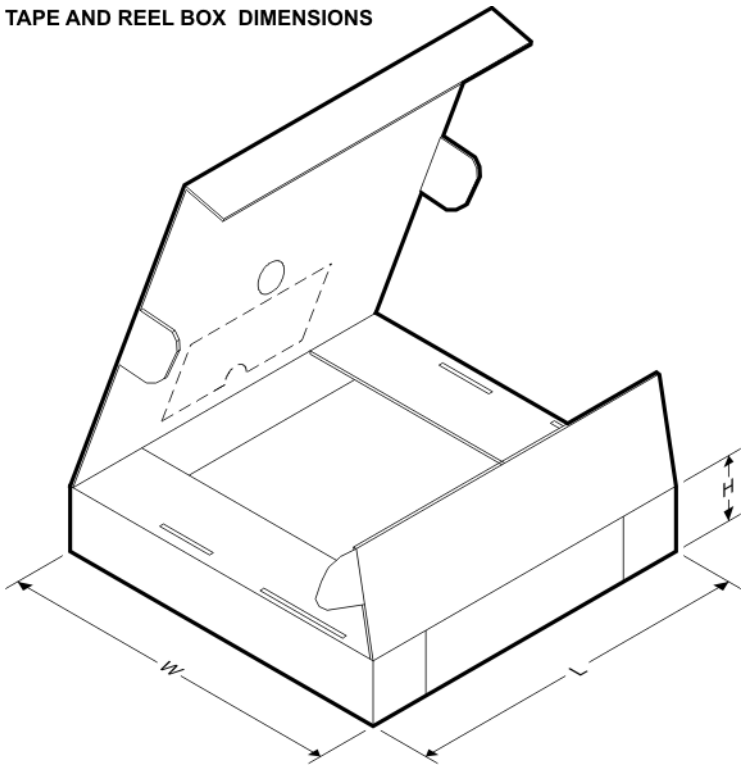
TAPE AND REEL BOX DIMENSIONS

*All dimensions are nominal

Device	Package Type	Package Drawing	Pins	SPQ	Length (mm)	Width (mm)	Height (mm)
TPS51216RUKR	WQFN	RUK	20	3000	338.0	355.0	50.0
TPS51216RUKT	WQFN	RUK	20	250	338.0	355.0	50.0

RUK (S-PWQFN-N20)

PLASTIC QUAD FLATPACK NO-LEAD

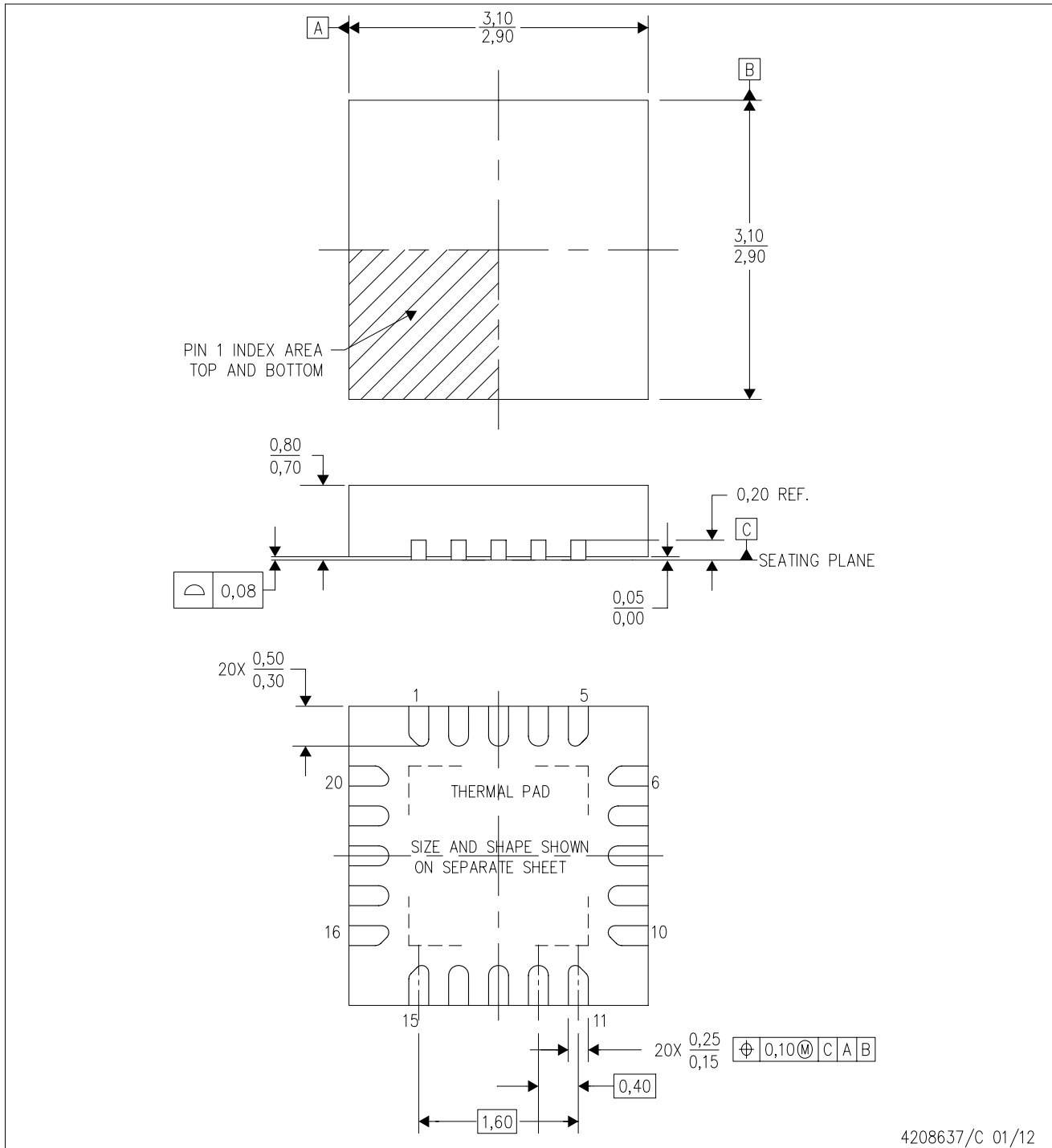

4208637/C 01/12

- NOTES:
- A. All linear dimensions are in millimeters. Dimensioning and tolerancing per ASME Y14.5M-1994.
 - B. This drawing is subject to change without notice.
 - C. Quad Flatpack, No-leads (QFN) package configuration.
 - D. The package thermal pad must be soldered to the board for thermal and mechanical performance.
 - E. See the additional figure in the Product Data Sheet for details regarding the exposed thermal pad features and dimensions.
 - F. Falls within JEDEC MO-220.

THERMAL PAD MECHANICAL DATA

RUK (S-PWQFN-N20)

PLASTIC QUAD FLATPACK NO-LEAD

THERMAL INFORMATION

This package incorporates an exposed thermal pad that is designed to be attached directly to an external heatsink. The thermal pad must be soldered directly to the printed circuit board (PCB). After soldering, the PCB can be used as a heatsink. In addition, through the use of thermal vias, the thermal pad can be attached directly to the appropriate copper plane shown in the electrical schematic for the device, or alternatively, can be attached to a special heatsink structure designed into the PCB. This design optimizes the heat transfer from the integrated circuit (IC).

For information on the Quad Flatpack No-Lead (QFN) package and its advantages, refer to Application Report, QFN/SON PCB Attachment, Texas Instruments Literature No. SLUA271. This document is available at www.ti.com.

The exposed thermal pad dimensions for this package are shown in the following illustration.

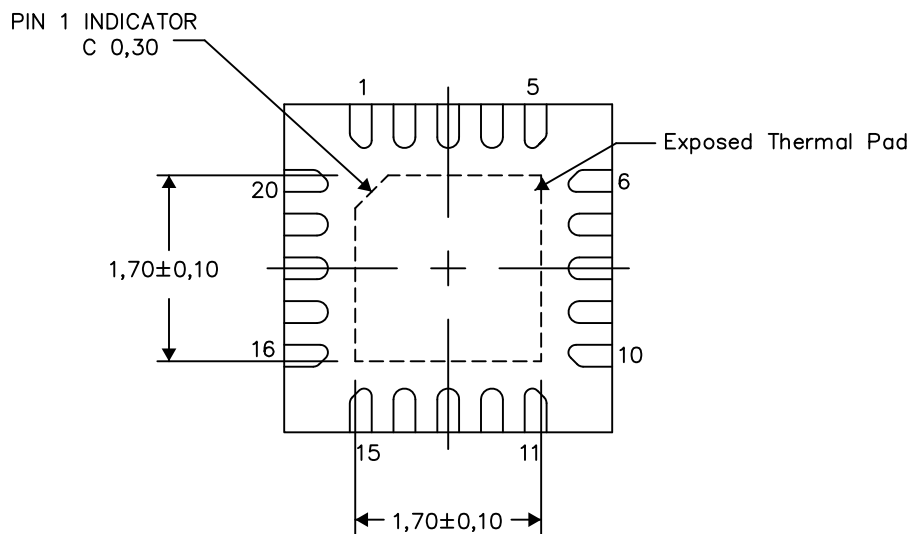

Exposed Thermal Pad Dimensions

4209762/1 05/15

NOTE: All linear dimensions are in millimeters

IMPORTANT NOTICE

Texas Instruments Incorporated (TI) reserves the right to make corrections, enhancements, improvements and other changes to its semiconductor products and services per JESD46, latest issue, and to discontinue any product or service per JESD48, latest issue. Buyers should obtain the latest relevant information before placing orders and should verify that such information is current and complete.

TI's published terms of sale for semiconductor products (<http://www.ti.com/sc/docs/stdterms.htm>) apply to the sale of packaged integrated circuit products that TI has qualified and released to market. Additional terms may apply to the use or sale of other types of TI products and services.

Reproduction of significant portions of TI information in TI data sheets is permissible only if reproduction is without alteration and is accompanied by all associated warranties, conditions, limitations, and notices. TI is not responsible or liable for such reproduced documentation. Information of third parties may be subject to additional restrictions. Resale of TI products or services with statements different from or beyond the parameters stated by TI for that product or service voids all express and any implied warranties for the associated TI product or service and is an unfair and deceptive business practice. TI is not responsible or liable for any such statements.

Buyers and others who are developing systems that incorporate TI products (collectively, "Designers") understand and agree that Designers remain responsible for using their independent analysis, evaluation and judgment in designing their applications and that Designers have full and exclusive responsibility to assure the safety of Designers' applications and compliance of their applications (and of all TI products used in or for Designers' applications) with all applicable regulations, laws and other applicable requirements. Designer represents that, with respect to their applications, Designer has all the necessary expertise to create and implement safeguards that (1) anticipate dangerous consequences of failures, (2) monitor failures and their consequences, and (3) lessen the likelihood of failures that might cause harm and take appropriate actions. Designer agrees that prior to using or distributing any applications that include TI products, Designer will thoroughly test such applications and the functionality of such TI products as used in such applications.

TI's provision of technical, application or other design advice, quality characterization, reliability data or other services or information, including, but not limited to, reference designs and materials relating to evaluation modules, (collectively, "TI Resources") are intended to assist designers who are developing applications that incorporate TI products; by downloading, accessing or using TI Resources in any way, Designer (individually or, if Designer is acting on behalf of a company, Designer's company) agrees to use any particular TI Resource solely for this purpose and subject to the terms of this Notice.

TI's provision of TI Resources does not expand or otherwise alter TI's applicable published warranties or warranty disclaimers for TI products, and no additional obligations or liabilities arise from TI providing such TI Resources. TI reserves the right to make corrections, enhancements, improvements and other changes to its TI Resources. TI has not conducted any testing other than that specifically described in the published documentation for a particular TI Resource.

Designer is authorized to use, copy and modify any individual TI Resource only in connection with the development of applications that include the TI product(s) identified in such TI Resource. NO OTHER LICENSE, EXPRESS OR IMPLIED, BY ESTOPPEL OR OTHERWISE TO ANY OTHER TI INTELLECTUAL PROPERTY RIGHT, AND NO LICENSE TO ANY TECHNOLOGY OR INTELLECTUAL PROPERTY RIGHT OF TI OR ANY THIRD PARTY IS GRANTED HEREIN, including but not limited to any patent right, copyright, mask work right, or other intellectual property right relating to any combination, machine, or process in which TI products or services are used. Information regarding or referencing third-party products or services does not constitute a license to use such products or services, or a warranty or endorsement thereof. Use of TI Resources may require a license from a third party under the patents or other intellectual property of the third party, or a license from TI under the patents or other intellectual property of TI.

TI RESOURCES ARE PROVIDED "AS IS" AND WITH ALL FAULTS. TI DISCLAIMS ALL OTHER WARRANTIES OR REPRESENTATIONS, EXPRESS OR IMPLIED, REGARDING RESOURCES OR USE THEREOF, INCLUDING BUT NOT LIMITED TO ACCURACY OR COMPLETENESS, TITLE, ANY EPIDEMIC FAILURE WARRANTY AND ANY IMPLIED WARRANTIES OF MERCHANTABILITY, FITNESS FOR A PARTICULAR PURPOSE, AND NON-INFRINGEMENT OF ANY THIRD PARTY INTELLECTUAL PROPERTY RIGHTS. TI SHALL NOT BE LIABLE FOR AND SHALL NOT DEFEND OR INDEMNIFY DESIGNER AGAINST ANY CLAIM, INCLUDING BUT NOT LIMITED TO ANY INFRINGEMENT CLAIM THAT RELATES TO OR IS BASED ON ANY COMBINATION OF PRODUCTS EVEN IF DESCRIBED IN TI RESOURCES OR OTHERWISE. IN NO EVENT SHALL TI BE LIABLE FOR ANY ACTUAL, DIRECT, SPECIAL, COLLATERAL, INDIRECT, PUNITIVE, INCIDENTAL, CONSEQUENTIAL OR EXEMPLARY DAMAGES IN CONNECTION WITH OR ARISING OUT OF TI RESOURCES OR USE THEREOF, AND REGARDLESS OF WHETHER TI HAS BEEN ADVISED OF THE POSSIBILITY OF SUCH DAMAGES.

Unless TI has explicitly designated an individual product as meeting the requirements of a particular industry standard (e.g., ISO/TS 16949 and ISO 26262), TI is not responsible for any failure to meet such industry standard requirements.

Where TI specifically promotes products as facilitating functional safety or as compliant with industry functional safety standards, such products are intended to help enable customers to design and create their own applications that meet applicable functional safety standards and requirements. Using products in an application does not by itself establish any safety features in the application. Designers must ensure compliance with safety-related requirements and standards applicable to their applications. Designer may not use any TI products in life-critical medical equipment unless authorized officers of the parties have executed a special contract specifically governing such use. Life-critical medical equipment is medical equipment where failure of such equipment would cause serious bodily injury or death (e.g., life support, pacemakers, defibrillators, heart pumps, neurostimulators, and implantables). Such equipment includes, without limitation, all medical devices identified by the U.S. Food and Drug Administration as Class III devices and equivalent classifications outside the U.S.

TI may expressly designate certain products as completing a particular qualification (e.g., Q100, Military Grade, or Enhanced Product). Designers agree that it has the necessary expertise to select the product with the appropriate qualification designation for their applications and that proper product selection is at Designers' own risk. Designers are solely responsible for compliance with all legal and regulatory requirements in connection with such selection.

Designer will fully indemnify TI and its representatives against any damages, costs, losses, and/or liabilities arising out of Designer's non-compliance with the terms and provisions of this Notice.

Looking for pricing, stock, or lifecycle information?

Click below to explore more details on WIN SOURCE:

 [View TPS51216RUKR](#) on WIN SOURCE

 [Texas Instruments](#) Information

Optimize Your Supply Chain with WIN SOURCE Solutions

-  Global Sourcing Solution
-  Obsolete Management
-  Cost Control Management
-  Shortage Management
-  Alternative Solution
-  Excess Inventory Management