



**THE DATASHEET OF  
TPS53114PWPR**



# TPS53114 Single Synchronous Step-down Controller for Low Voltage Power Rails

## 1 Features

- D-CAP2™ Mode Control
  - Fast Transient Response
  - No External Parts Required For Loop Compensation
  - Compatible with Ceramic Output Capacitors
- High Initial Reference Accuracy ( $\pm 1\%$ )
- Low Output Ripple
- Wide Input Voltage Range: 4.5 V to 24 V
- Output Voltage Range: 0.76 V to 5.5 V
- Low-Side  $R_{DS(on)}$  Loss-Less Current Sensing
- Adaptive Gate Drivers with Integrated Boost Diode
- Adjustable Soft Start
- Pre-Biased Soft Start
- Selectable Switching Frequency  
350 kHz / 700 kHz
- Cycle-By-Cycle Over Current Limiting Control
- Thermally Compensated OCP by 4000 ppm/°C at  $I_{TRIP}$

## 2 Applications

- Point-of-Load Regulation in Low Power Systems for Wide Range of Applications
  - Digital TV Power Supply
  - Networking Home Terminal
  - Digital Set Top Box (STB)
  - DVD Player / Recorder
  - Gaming Consoles

## 4 Simplified Schematics

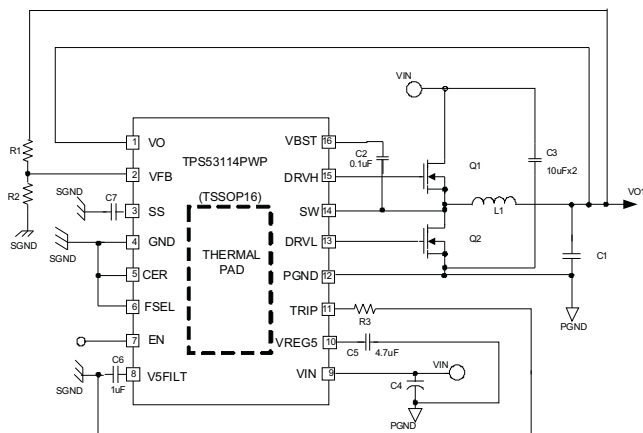

## 3 Description

The TPS53114 is a single, adaptive on-time D-CAP2™ mode synchronous buck controller. The TPS53114 enables system designers to complete the suite of various end equipment's power bus regulators with cost effective low external component count and low standby current solution. The main control loop for the TPS53114 uses the D-CAP2™ mode control which provides a very fast transient response with no external components. The TPS53114 also has a circuit that enables the device to adapt to both low equivalent series resistance (ESR) output capacitors such as POSCAP or SP-CAP and ultra-low ESR ceramic capacitors. The device provides convenient and efficient operation with input voltages from 4.5 V to 24 V and output voltage from 0.76 V to 5.5 V.

The TPS53114 is available in the 16-pin TSSOP and HTSSOP packages, and is specified from  $-40^{\circ}\text{C}$  to  $85^{\circ}\text{C}$  ambient temperature range.

### Device Information<sup>(1)</sup>

PART NUMBER	PACKAGE	BODY SIZE (NOM)
TPS53114	TSSOP (16)	5.00 mm x 4.40 mm
TPS53114	HTSSOP (916)	5.00 mm x 4.40 mm

(1) For all available packages, see the orderable addendum at the end of the datasheet.

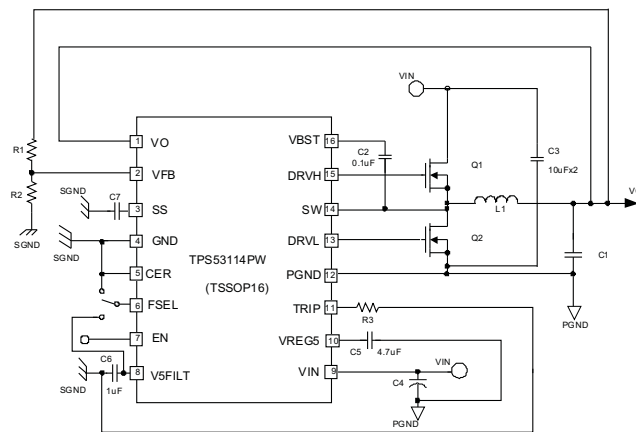

## Table of Contents

<b>1 Features</b> .....	<b>1</b>	8.2 Functional Block Diagram .....	<b>9</b>
<b>2 Applications</b> .....	<b>1</b>	8.3 Feature Description .....	<b>9</b>
<b>3 Description</b> .....	<b>1</b>	8.4 Device Functional Modes .....	<b>11</b>
<b>4 Simplified Schematics</b> .....	<b>1</b>	<b>9 Application and Implementation</b> .....	<b>12</b>
<b>5 Revision History</b> .....	<b>2</b>	9.1 Application Information .....	<b>12</b>
<b>6 Pin Configurations and Functions</b> .....	<b>3</b>	9.2 350-kHz Operation Application .....	<b>12</b>
<b>7 Specifications</b> .....	<b>4</b>	9.3 700 kHz Operation Application .....	<b>16</b>
7.1 Absolute Maximum Ratings .....	<b>4</b>	<b>10 Power Supply Recommendations</b> .....	<b>18</b>
7.2 Handling Ratings .....	<b>4</b>	<b>11 Layout</b> .....	<b>18</b>
7.3 Recommended Operating Conditions .....	<b>4</b>	11.1 Layout Guidelines .....	<b>18</b>
7.4 Thermal Information .....	<b>5</b>	11.2 Layout Example .....	<b>18</b>
7.5 Electrical Characteristics .....	<b>5</b>	<b>12 Device and Documentation Support</b> .....	<b>20</b>
7.6 Timing Requirements .....	<b>6</b>	12.1 Trademarks .....	<b>20</b>
7.7 Switching Characteristics .....	<b>6</b>	12.2 Electrostatic Discharge Caution .....	<b>20</b>
7.8 Typical Characteristics .....	<b>7</b>	12.3 Glossary .....	<b>20</b>
<b>8 Detailed Description</b> .....	<b>9</b>	<b>13 Mechanical, Packaging, and Orderable Information</b> .....	<b>20</b>
8.1 Overview .....	<b>9</b>		

## 5 Revision History

NOTE: Page numbers for previous revisions may differ from page numbers in the current version.

<b>Changes from Revision B (October 2010) to Revision C</b>	<b>Page</b>
• Changed the datasheet to the new TI standard format .....	<b>1</b>
• Added Thermal PWP information .....	<b>5</b>
• Changed from 4.8 V to 4.6 V. ....	<b>5</b>
• Changed from 8 to 12 Ω. ....	<b>5</b>
• Added Figures 8 and 9 .....	<b>8</b>
• Added "The TPS53114 enables system designers to complete the suite of various end equipment power bus regulators with cost effective, low external component count and low standby current solution." .....	<b>9</b>
• Changed <a href="#">Equation 1</a> .....	<b>11</b>

<b>Changes from Revision A (August 2009) to Revision B</b>	<b>Page</b>
• Changed From: $I_{OCL} + T_O: I_{OCL} -$ .....	<b>14</b>
• Added minus $V_{OCLoff}$ .....	<b>14</b>

## 6 Pin Configurations and Functions

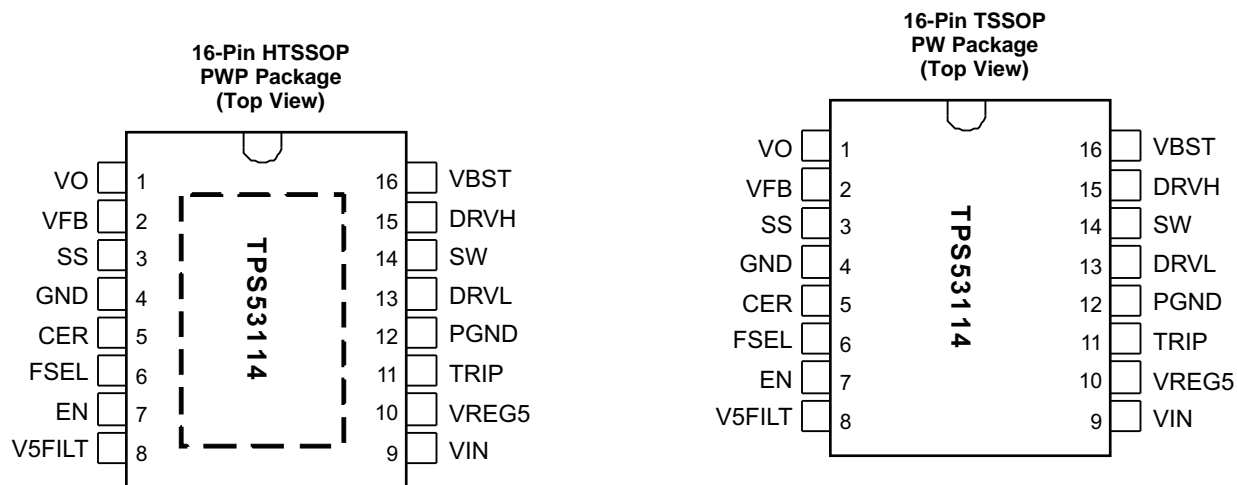

### Pin Functions

PIN		I/O	DESCRIPTION
NAME	NUMBER		
VBST	16	I	Supply input for high-side NFET driver. Bypass to SW with a high-quality 0.1- $\mu$ F ceramic capacitor. An external schottky diode can be added from VREG5 if forward drop is critical to drive the high-side FET.
EN	7	I	Enable. Pull High to enable SMPS.
SS	3	O	Soft start programming pin. Connect capacitor from SS pin to GND to program soft start time.
VO	1	I	Output voltage input for on-time adjustment and output discharge. Connect directory to the output voltage.
VFB	2	I	D-CAP2 feedback input. Connect to output voltage with resistor divider.
GND	4	I	Signal ground pin. Connect to PGND and system ground at a single point.
DRVH	15	O	High-side N-channel MOSFET gate driver output. SW referenced driver switches between SW(OFF) and VBST(ON).
SW	14	I/O	Switch node connections for both the high-side driver and over current comparator.
DRVL	13	O	Low-side N-Channel MOSFET gate driver output. PGND referenced driver switches between PGND(OFF) and VREG5(ON).
PGND	12	I/O	Power ground connection for both the low-side driver and over current comparator. Connect PGND and GND strongly together near the IC.
TRIP	11	I	over current threshold programming pin. Connect to GND with a resistor to set threshold for low-side $R_{DS(on)}$ current limit.
VIN	9	I	Supply Input for 5-V linear regulator. Bypass to GND with a minimum high-quality 0.1- $\mu$ F ceramic capacitor.
V5FILT	8	I	5-V supply input for the control circuitry except the MOSFET drivers. Bypass to GND with a minimum high-quality 1.0- $\mu$ F ceramic capacitor. V5FILT is connected to VREG5 via internal 10- $\Omega$ resistor.
VREG5	10	O	Output of 5-V linear regulator and supply for MOSFET driver. Bypass to GND with a minimum high-quality 4.7- $\mu$ F ceramic capacitor. VREG5 is connected to V5FILT via internal 10- $\Omega$ resistor.
CER	5	I	Output capacitor select pin. Connect to GND for ceramic output capacitors. Connect to V5FILT for conductive polymer electrolyte type output capacitors (SP-CAP, POS-CAP, PXE).
FSEL	6	I	Switching frequency selection pin. Connect to GND for low switching frequency or connect to V5FILT for high switching frequency.

## 7 Specifications

### 7.1 Absolute Maximum Ratings

over operating free-air temperature range (unless otherwise noted) <sup>(1)</sup>

			MIN	MAX	UNIT
	Input voltage range	VIN, EN	-0.3	26	V
		VBST	-0.3	32	
		VBST - SW	-0.3	6	
		V5FILT, VFB, TRIP, VO, FSEL, CER	-0.3	6	
	Output voltage range	DRVH	-1	32	V
		DRVH - SW	-0.3	6	
		SW	-2	26	
		DRVL, VREG5, SS	-0.3	6	
		PGND	-0.3	0.3	
T <sub>A</sub>	Operating ambient temperature range		-40	85	°C
T <sub>J</sub>	Junction temperature range		-40	150	°C

(1) Stresses beyond those listed under *Absolute Maximum Ratings* may cause permanent damage to the device. These are stress ratings only, which do not imply functional operation of the device at these or any other conditions beyond those indicated under *Recommended Operating Conditions*. Exposure to absolute-maximum-rated conditions for extended periods may affect device reliability.

### 7.2 Handling Ratings

			MIN	MAX	UNIT
T <sub>stg</sub>	Storage temperature		-55	150	°C
V <sub>(ESD)</sub>	Electrostatic discharge	Human body model (HBM), per ANSI/ESDA/JEDEC JS-001, all pins <sup>(1)</sup>	-2000	2000	V
		Charged device model (CDM), per JEDEC specification JESD22-C101, all pins <sup>(2)</sup>	-500	500	

(1) JEDEC document JEP155 states that 500-V HBM allows safe manufacturing with a standard ESD control process.

(2) JEDEC document JEP157 states that 250-V CDM allows safe manufacturing with a standard ESD control process.

### 7.3 Recommended Operating Conditions

over operating free-air temperature range (unless otherwise noted)

			MIN	MAX	UNIT
	Supply input voltage	VIN	4.5	24	V
		V5FILT	4.5	5.5	
	Input voltage	VBST	-0.1	30	V
		VBST - SW	-0.1	5.5	
		VFB, VO, FSEL, CER	-0.1	5.5	
		TRIP	-0.1	0.3	
		EN	-0.1	24	
	Output voltage	DRVH	-0.1	30	V
		VBST - SW	-0.1	5.5	
		SW	1.8	24	
		DRVL, VREG5, SS	-0.1	5.5	
		PGND	-0.1	0.1	
T <sub>A</sub>	Operating free-air temperature		-40	85	°C
T <sub>J</sub>	Operating junction temperature		-40	125	°C

## 7.4 Thermal Information

THERMAL METRIC <sup>(1)</sup>		TPS53114		UNIT
		PWP (16 PINS)	PW (16 PINS)	
R <sub>θJA</sub>	Junction-to-ambient thermal resistance	51.2	109.6	°C/W
R <sub>θJC(top)</sub>	Junction-to-case (top) thermal resistance	33.4	31.2	
R <sub>θJB</sub>	Junction-to-board thermal resistance	28.3	54.7	
Ψ <sub>JT</sub>	Junction-to-top characterization parameter	1.4	0.9	
Ψ <sub>JB</sub>	Junction-to-board characterization parameter	28.1	54.1	
R <sub>θJC(bot)</sub>	Junction-to-case (bottom) thermal resistance	4.9	n/a	

(1) For more information about traditional and new thermal metrics, see the *IC Package Thermal Metrics* application report, [SPRA953](#).

## 7.5 Electrical Characteristics

over operating free-air temperature range (unless otherwise noted)

PARAMETER		TEST CONDITIONS	MIN	TYP	MAX	UNIT
<b>SUPPLY CURRENT</b>						
I <sub>IN</sub>	VIN supply current	VIN current, T <sub>A</sub> = 25°C, VREG5 tied to V5FLT, EN = 5V, VFB = 0.8V, SW = 0.5V		350	600	μA
I <sub>VINSDN</sub>	VIN shutdown current	VIN current, T <sub>A</sub> = 25°C, No Load, EN = 0V, VREG5 = ON		28	60	μA
<b>VFB VOLTAGE and DISCHARGE RESISTANCE</b>						
V <sub>BG</sub>	Bandgap Initial regulation accuracy	T <sub>A</sub> = 25°C	-1.0%		1.0%	
V <sub>VFBTHL</sub>	VFB threshold voltage	T <sub>A</sub> = 25°C, FSEL = 0V, CER = V5FILT	755	765	775	mV
		T <sub>A</sub> = -40°C to 85°C, FSEL = 0V, CER = V5FILT	752		778	
V <sub>VFBTHH</sub>	VFB threshold voltage	T <sub>A</sub> = 25°C, FSEL = CER = V5FILT	748	758	768	mV
		T <sub>A</sub> = -40°C to 85°C, FSEL = CER = V5FILT	745		771	
I <sub>VFB</sub>	VFB input current	VFB = 0.8V, T <sub>A</sub> = 25°C	-100	-10	100	nA
R <sub>Dischg</sub>	Vo discharge resistance	EN = 0V, VO = 0.5V, T <sub>A</sub> = 25°C		40	80	Ω
<b>VREG5 OUTPUT</b>						
V <sub>VREG5</sub>	VREG5 output voltage	T <sub>A</sub> = 25°C, 5.5V < VIN < 24V, 0 < I <sub>VREG5</sub> < 10mA	4.6	5.0	5.2	V
V <sub>LN5</sub>	Line regulation	5.5V < VIN < 24V, I <sub>VREG5</sub> = 10mA			20	mV
V <sub>LD5</sub>	Load regulation	1mA < I <sub>VREG5</sub> < 10mA			40	mV
I <sub>VREG5</sub>	Output current	VIN = 5.5V, V <sub>VREG5</sub> = 4.0V, T <sub>A</sub> = 25°C		170		mA
<b>OUTPUT: N-CHANNEL MOSFET GATE DRIVERS</b>						
R <sub>DRVH</sub>	DRVH resistance	Source, I <sub>DRVH</sub> = -100mA		5.5	11	Ω
		Sink, I <sub>DRVH</sub> = 100mA		2.5	5	
R <sub>DRVL</sub>	DRVL resistance	Source, I <sub>DRVL</sub> = -100mA		4	12	Ω
		Sink, I <sub>DRVL</sub> = 100mA		2	4	
<b>INTERNAL BST DIODE</b>						
V <sub>FBST</sub>	Forward voltage	V <sub>VREG5-VBST</sub> , I <sub>F</sub> = 10mA, T <sub>A</sub> = 25°C	0.7	0.8	0.9	V
I <sub>VBSTLK</sub>	VBST leakage current	VBST = 29V, SW = 24V, T <sub>A</sub> = 25°C		0.1	1	μA
<b>SOFT START</b>						
I <sub>SSC</sub>	SS charge current	VSS = 0V, SOURCE CURRENT	1.4	2.0	2.6	μA
I <sub>SSD</sub>	SS discharge current	VSS = 0.5V, SINK CURRENT	100	150		μA
<b>UVLO</b>						
V <sub>UV5VFILT</sub>	V5FILT UVLO threshold	V5FILT rising	3.7	4.0	4.3	V
		Hysteresis	0.2	0.3	0.4	

## Electrical Characteristics (continued)

over operating free-air temperature range (unless otherwise noted)

PARAMETER		TEST CONDITIONS	MIN	TYP	MAX	UNIT
<b>LOGIC THRESHOLD</b>						
V <sub>ENH</sub>	EN H-level threshold voltage	EN	2.0			V
V <sub>ENL</sub>	EN L-level threshold voltage	EN			0.3	V
<b>CURRENT SENSE</b>						
I <sub>TRIP</sub>	TRIP source current	V <sub>TRIP</sub> = 0.1V, T <sub>A</sub> = 25°C	8.5	10	11.5	μA
T <sub>C</sub> I <sub>TRIP</sub>	I <sub>TRIP</sub> temperature coefficient	on the basis of 25°C		4000		ppm/°C
V <sub>OCLoff</sub>	OCP compensation offset	(V <sub>TRIP-GND</sub> -V <sub>PGND-SW</sub> ) voltage, V <sub>TRIP-GND</sub> = 60mV, T <sub>A</sub> = 25°C	-10	0	10	mV
		(V <sub>TRIP-GND</sub> -V <sub>PGND-SW</sub> ) voltage, V <sub>TRIP-GND</sub> = 60mV	-15		15	
V <sub>Rtrip</sub>	Current limit threshold setting range	V <sub>TRIP-GND</sub> voltage	30		200	
<b>OUTPUT UNDERVOLTAGE AND OVERVOLTAGE PROTECTION</b>						
V <sub>OVP</sub>	Output OVP trip threshold	OVP detect	110%	115%	120%	
V <sub>UVP</sub>	Output UVP trip threshold	UVP detect	65%	70%	75%	
		Hysteresis (recovery <20μs)		10%		
<b>THERMAL</b>						
T <sub>SDN</sub>	Thermal shutdown threshold	Shutdown temperature <sup>(1)</sup>		150		°C
		Hysteresis <sup>(1)</sup>		20		

(1) Specified by design. Not production tested.

## 7.6 Timing Requirements

PARAMETER		TEST CONDITIONS	MIN	TYP	MAX	UNIT
<b>OUTPUT: N-CHANNEL MOSFET GATE DRIVERS</b>						
t <sub>D</sub>	Dead time	DRVH-low to DRVL-on	20	50	80	ns
		DRVL-low to DRVH-on	20	40	80	
<b>OUTPUT UNDERVOLTAGE AND OVERVOLTAGE PROTECTION</b>						
t <sub>OVPDEL</sub>	Output OVP prop delay			1.5		μs
t <sub>UVPDEL</sub>	Output UVP delay		17	30	40	μs
t <sub>UVPEN</sub>	Output UVP enable delay	UVP enable delay / soft start time	X1.4	X1.7	X2.0	

## 7.7 Switching Characteristics

over operating free-air temperature range (unless otherwise noted)

PARAMETER		TEST CONDITIONS	MIN	TYP	MAX	UNIT
<b>ON-TIME TIMER CONTROL</b>						
t <sub>ONL</sub>	On time	SW = 12V, VO = 1.8V, FSEL = 0V		390		ns
t <sub>ONH</sub>	On time	SW = 12V, VO = 1.8V, FSEL = V5FILT		139		ns
t <sub>OFFL</sub>	Min off time	SW = 0.7V, T <sub>A</sub> = 25°C, VFB = 0.7V, FSEL = 0V		285		ns
t <sub>OFFH</sub>	Min off time	SW = 0.7V, T <sub>A</sub> = 25°C, VFB = 0.7V, FSEL = V5FILT		216		ns

### 7.8 Typical Characteristics

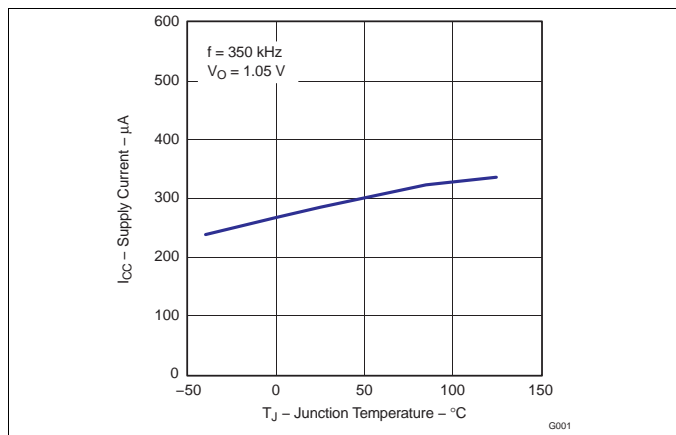

Figure 1. VIN Supply Current vs Junction Temperature

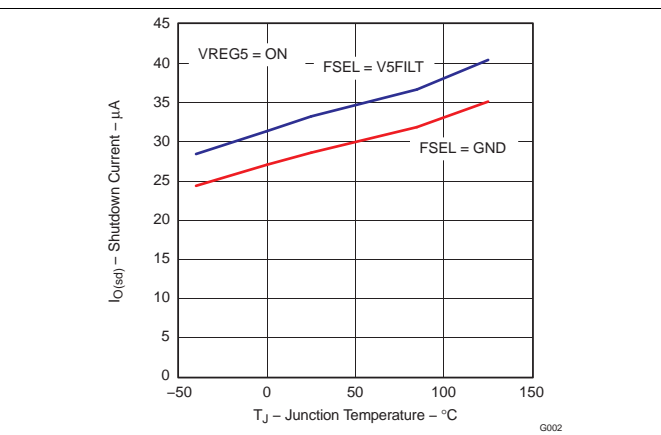

Figure 2. VIN Shutdown Current vs Junction Temperature

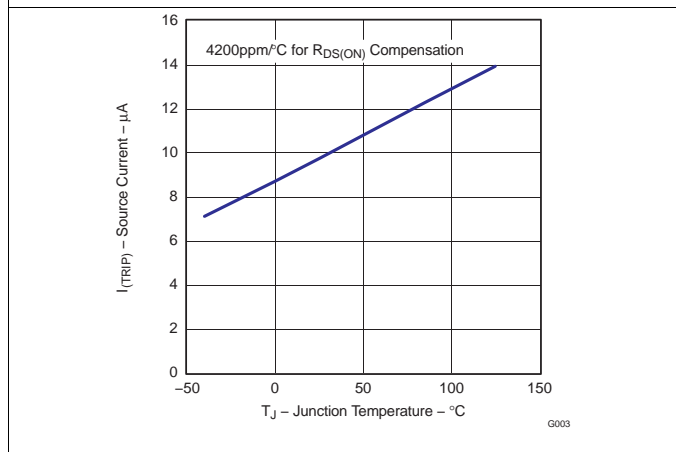

Figure 3. Trip Source Current vs Junction Temperature

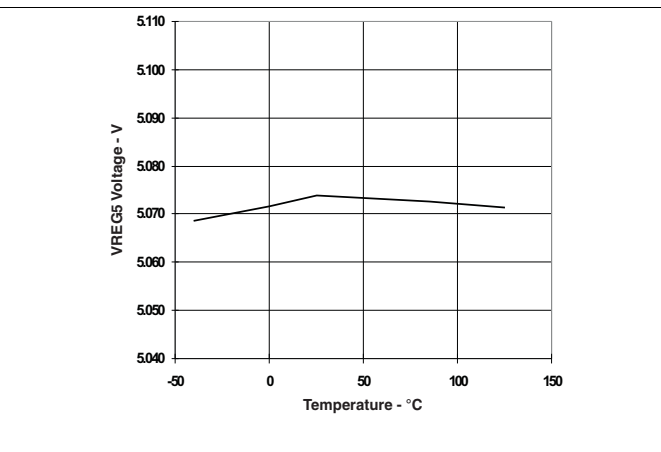

Figure 4. VREG5 Voltage

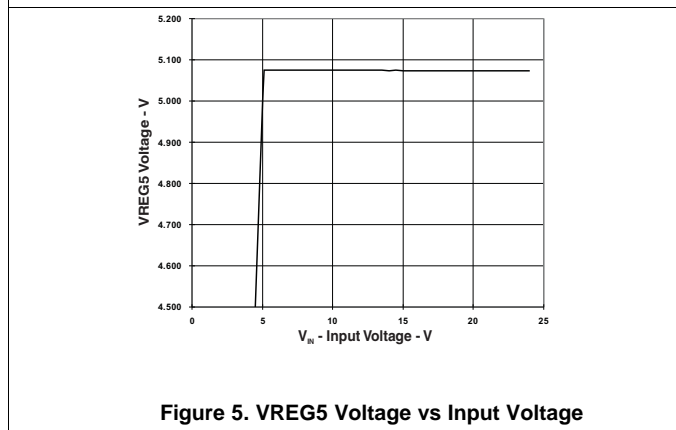

Figure 5. VREG5 Voltage vs Input Voltage

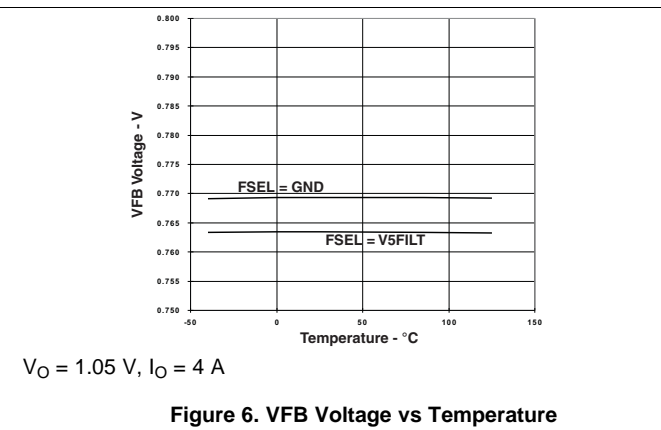

Figure 6. VFB Voltage vs Temperature

Typical Characteristics (continued)

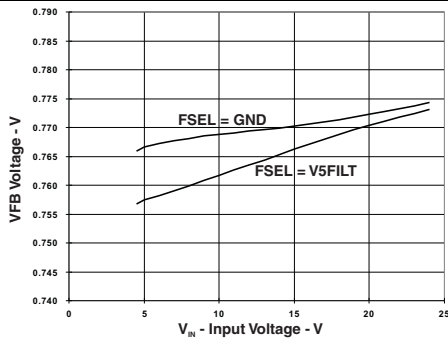

Figure 7. VFB Voltage vs Input Voltage

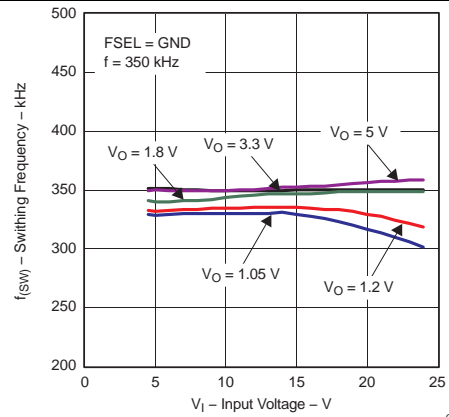

Figure 8. Switching Frequency ( $I_O = 1\text{ A}$ ) vs. Input Voltage

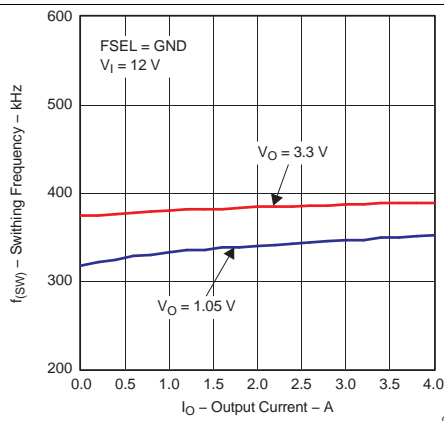

Figure 9. Switching Frequency vs. Output Current

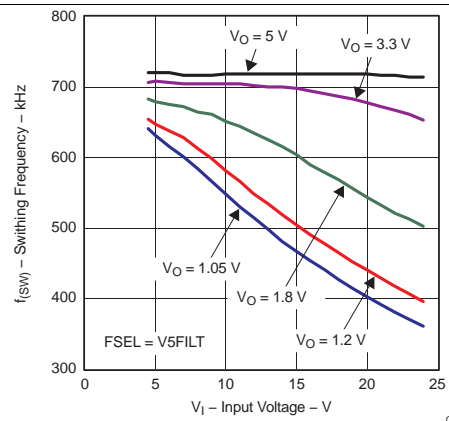

Figure 10. Switching Frequency vs. Input Voltage

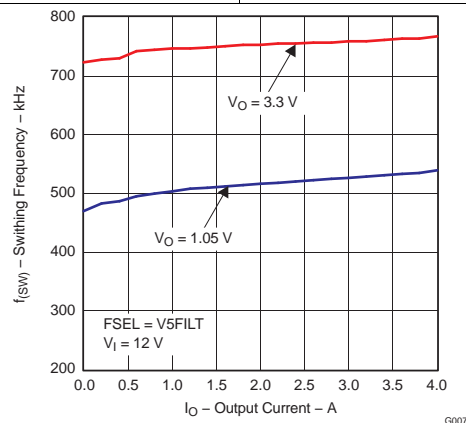

Figure 11. Switching Frequency vs. Output Current

## 8 Detailed Description

### 8.1 Overview

The TPS53114 is a single, adaptive on-time D-CAP2™ mode synchronous buck controller. The TPS53114 enables system designers to complete the suite of various end equipment power bus regulators with cost effective, low external component count and low standby current solution. The main control loop for the TPS53114 uses the D-CAP2™ mode control which provides a very fast transient response with no external compensation components. The TPS53114 also has a circuit that enables the device to adapt to both low equivalent series resistance (ESR) output capacitors such as POSCAP or SP-CAP and ultra-low ESR ceramic capacitors. The device provides convenient and efficient operation with input voltages from 4.5 V to 24 V and output voltage from 0.76 V to 5.5 V.

### 8.2 Functional Block Diagram

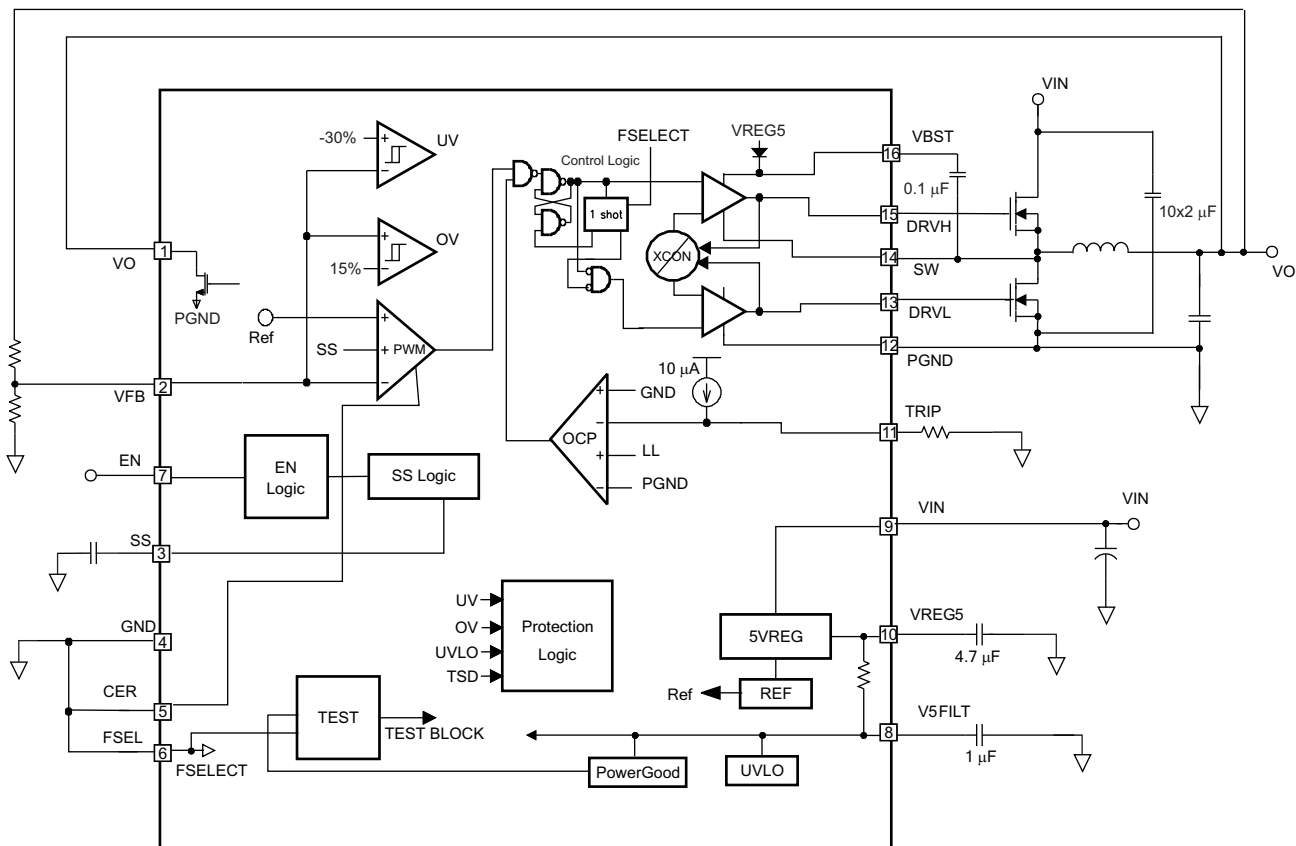

### 8.3 Feature Description

#### 8.3.1 PWM Operation

The main control loop of the TPS53114 is an adaptive on-time pulse width modulation (PWM) controller using a proprietary D-CAP2™ mode control. D-CAP2™ mode control combines constant on-time control with an internal compensation circuit for pseudo-fixed frequency and low external component count configuration with both low ESR and ceramic output capacitors. It is stable even with virtually no ripple at the output.

At the beginning of each cycle, the high-side MOSFET is turned on. After an internal one-shot timer expires, this MOSFET is turned off. The one-shot timer is reset and the high-side MOSFET is turned back on when the feedback voltage falls below the reference voltage. The one shot is set by the converter input voltage VIN, and the output voltage VO, to maintain a pseudo-fixed frequency over the input voltage range, hence it is called adaptive on-time control. An internal ramp is added to the reference voltage to simulate output ripple, eliminating the need for ESR induced output ripple from D-CAP mode control.

## Feature Description (continued)

### 8.3.2 Drivers

The TPS53114 contains two high-current resistive MOSFET gate drivers. The low-side driver is a ground referenced, VREG5 powered driver designed to drive the gate of a high-current, low  $R_{DS(on)}$  N-channel MOSFET whose source is connected to PGND. The high-side driver is a floating SW referenced VBST powered driver designed to drive the gate of a high-current, low  $R_{DS(on)}$  N-channel MOSFET. To maintain the VBST voltage during the high-side driver ON time, a capacitor is placed from SW to VBST. Each driver draws average current equal to gate charge ( $Q_g$  at  $V_{GS} = 5\text{ V}$ ) times switching frequency ( $f_{sw}$ ).

To prevent cross-conduction, there is a narrow dead-time when both high-side and low-side drivers are OFF between each driver transition. During this time the inductor current is carried by one of the MOSFET's body diodes.

### 8.3.3 PWM Frequency and Adaptive On-time Control

TPS53114 employs adaptive on-time control scheme and does not have a dedicated on board oscillator. TPS53114 runs with pseudo-constant frequency by using the input voltage and output voltage to set the on-time one-shot timer. The on-time is inversely proportional to the input voltage and proportional to the output voltage. Therefore, when the duty ratio is  $V_{OUT}/V_{IN}$ , the frequency is constant.

### 8.3.4 5-Volt Regulator

The TPS53114 has an internal 5-V low-dropout (LDO) Regulator to provide a regulated voltage for all both drivers and the IC's internal logic. A high-quality 4.7- $\mu\text{F}$  or greater ceramic capacitor from VREG5 to GND is required to stabilize the internal regular. An internal 10- $\Omega$  resistor from VREG5 filters the regulator output to the IC's analog and logic input voltage, V5FILT. An additional high-quality 1.0- $\mu\text{F}$  ceramic capacitor is required from V5FILT to GND to filter switching noise from VREG5.

### 8.3.5 Soft Start

The TPS53114 has a programmable soft start . When the EN pin becomes high, 2.0- $\mu\text{A}$  current begins charging the capacitor which is connected SS pin to GND. Smooth control of the output voltage is maintained during start up.

### 8.3.6 Pre-bias Support

The TPS53114 supports pre-bias start-up without sinking current from the output capacitor. When enabled, the low-side driver is held off until the soft start commands a voltage higher than the pre-bias level (internal soft start becomes greater than feedback voltage (VFB)), then the TPS53114 slowly activates synchronous rectification by limiting the first DRVL pulses with a narrow on-time. This limited on-time is then incremented on a cycle-by-cycle basis until it coincides with the full 1-D off-time. This scheme prevents the initial sinking of current from the pre-bias output, and ensure that the output voltage ( $V_{OUT}$ ) starts and ramps up smoothly into regulation and the control loop is given time to transition from pre-biased start-up to normal mode operation.

### 8.3.7 Switching Frequency Selection

The TPS53114 allows the user to select from two different switching frequencies by connecting the FSEL pin to either GND or V5FILT. Connect FSEL to GND for a switching frequency ( $f_{sw}$ ) of 350 KHz. Connect FSEL to V5FILT for a switching frequency of 700 KHz.

### 8.3.8 Output Discharge Control

The TPS53114 discharges the outputs when EN is low, or the controller is turned off by the protection functions (OVP, UVP, UVLO, and thermal shutdown). The device discharges output using an internal 40- $\Omega$  MOSFET which is connected to VO and PGND. The external low-side MOSFET is not turned on during the output discharge operation to avoid the possibility of causing negative voltage at the output. This discharge ensures that, on start, the regulated voltage always initializes from 0 V.

## Feature Description (continued)

### 8.3.9 Over Current Protection

TPS53114 has a cycle-by-cycle over current limit feature. The over current limits the inductor valley current by monitoring the voltage drop across the low-side MOSFET  $R_{DS(on)}$  during the low-side driver on-time. If the inductor current is larger than the over current limit (OCL), the TPS53114 delays the start of the next switching cycle until the sensed inductor current falls below the OCL current. MOSFET  $R_{DS(on)}$  current sensing is used to provide an accuracy and cost effective solution without external devices. To program the OCL, the TRIP pin should be connected to GND through a trip voltage setting resistor, according to [Equation 1](#) and [Equation 2](#).

$$V_{TRIP} = \left( I_{OCL} - \frac{(V_{IN} - V_O)}{2 \cdot L1 \cdot f_{sw}} \cdot \frac{V_O}{V_{IN}} \right) \cdot R_{DS(ON)} \quad (1)$$

$$R_{TRIP}(k\Omega) = \frac{V_{TRIP}(mV)}{I_{TRIP}(\mu A)} \quad (2)$$

The trip voltage should be between 30 mV to 200 mV over all operational temperature, including the 4000 ppm/°C temperature slope compensation for the temperature dependency of the  $R_{DS(on)}$ . If the load current exceeds the over current limit, the voltage will begin to drop. If the over current conditions continues, the output voltage will fall below the under voltage protection threshold and the TPS53114 will shut down.

### 8.3.10 Over/under Voltage Protection

TPS53114 monitors a resistor divided feedback voltage to detect over and under voltage. If the feedback voltage is higher than 115% of the reference voltage, the OVP comparator output goes high and the circuit latches the high-side MOSFET driver OFF and the low-side MOSFET driver ON. When the feedback voltage is lower than 70% of the reference voltage, the UVP comparator output goes high and an internal UVP delay counter begins counting. After 30  $\mu$ s, TPS53114 latches OFF both top and bottom MOSFET drivers. This function is enabled approximately 1.7x  $T_{SS}$  after power-on. The OVP and UVP latch off is reset when EN goes low level.

### 8.3.11 UVLO Protection

TPS53114 has V5FILT under voltage lock out protection (UVLO) that monitors the voltage of V5FILT pin. When the V5FILT voltage is lower than UVLO threshold voltage, the device is shut off. All output drivers are OFF and output discharge is ON. The UVLO is non-latch protection.

### 8.3.12 Thermal Shutdown

The TPS53114 includes an over temperature protection shut-down feature. If the TPS53114 die temperature exceeds the OTP threshold (typically 150°C), both the high-side and low-side drivers are shut off, the output voltage discharge function is enabled and then the device is shut off until the die temperature drops. Thermal shutdown is a non-latch protection.

## 8.4 Device Functional Modes

### 8.4.1 Operation

The TPS53114 has two operating modes. The TPS53114 is in shut down mode when the EN pin is low. When the EN pin is pulled high, the TPS53114 enters the normal operating mode.

## 9 Application and Implementation

### 9.1 Application Information

#### 9.2 350-kHz Operation Application

The schematic of Figure 12 shows a typical 350-kHz application schematic. The 350 kHz switching frequency is selected by connecting FSEL to the GND pin. The input voltage is 12 V and the output voltage is 1.05 V.

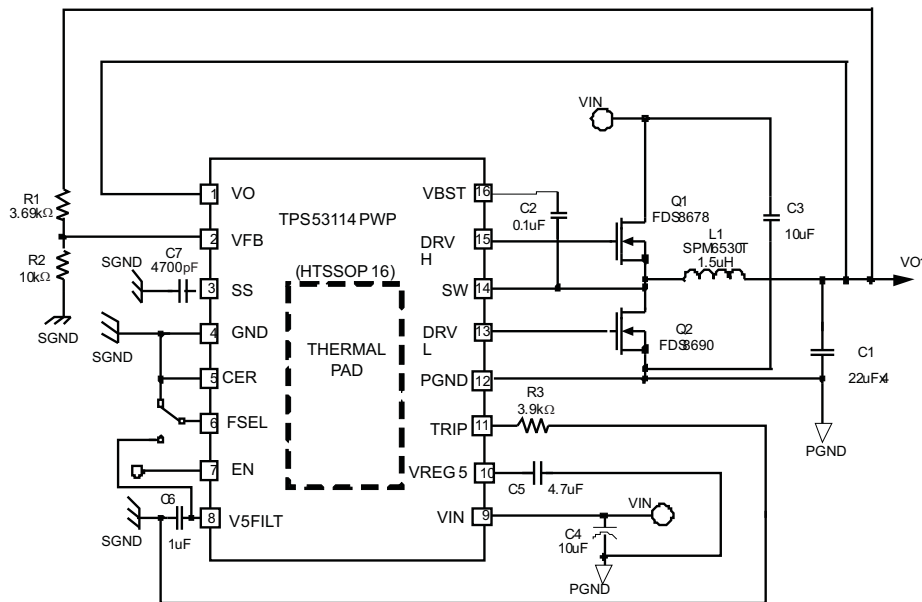

Figure 12. Typical Application Circuit at 350-kHz Switching Frequency Selection (FSEL pin = GND)

#### 9.2.1 Design Requirements

Table 1. Design Parameters

PARAMETERS	EXAMPLE VALUES
Input voltage	12 V
Output voltage	1.05 V
Output current	4 A
Switching frequency	350 kHz

#### 9.2.2 Detailed Design Procedure

##### 9.2.2.1 Choose Inductor

The inductance value is selected to provide approximately 30% peak to peak ripple current at maximum load. Larger ripple current increases output ripple voltage, improve S/N ratio and contribute to stable operation. L1 can be calculated using Equation 3.

$$L1 = \frac{(V_{IN(max)} - V_{O1})}{I_{L(ripple)} \cdot f_{SW}} \cdot \frac{V_{O1}}{V_{IN(max)}} = \frac{3 \cdot (V_{IN(max)} - V_{O1})}{I_{O1} \cdot f_{SW}} \cdot \frac{V_{O1}}{V_{IN(max)}} \quad (3)$$

The inductors current ratings needs to support both the RMS (thermal) current and the peak (saturation) current. The RMS and peak inductor current can be estimated as follows:

$$I_{L(ripple)} = \frac{V_{IN(max)} - V_{O1}}{L1 \cdot f_{SW}} \cdot \frac{V_{O1}}{V_{IN(max)}} \quad (4)$$

$$I_{L1(peak)} = \frac{V_{TRIP}}{R_{DS(ON)}} + I_{L1(ripple)} \quad (5)$$

$$I_{L1(RMS)} = \sqrt{I_O^2 + \frac{1}{12}(I_{L1(ripple)})^2} \quad (6)$$

**Note:**

The calculation above shall serve as a general reference. To further improve transient response, the output inductance could be reduced further. This needs to be considered along with the selection of the output capacitor.

**9.2.2.2 Choose Output Capacitor**

The capacitor value and ESR determines the amount of output voltage ripple and load transient response. Recommend to use ceramic output capacitor.

$$C1 = \frac{\Delta I_{load}^2 \cdot L1}{2 \cdot V_{O1} \cdot \Delta V_{OS}} \quad (7)$$

$$C1 = \frac{\Delta I_{load}^2 \cdot L1}{2 \cdot K \cdot \Delta V_{US}} \quad (8)$$

Where:

$$K = (V_{IN} - V_{O1}) \cdot \frac{T_{on}}{T_{ON} + T_{min(off)}} \quad (9)$$

$$C1 = \frac{I_{L1(ripple)}}{8 \cdot V_{O1(ripple)}} \cdot \frac{1}{f_{SW}} \quad (10)$$

Select the capacitance value greater than the largest value calculated from [Equation 7](#), [Equation 8](#) and [Equation 10](#). The capacitance for C1 should be greater than 66  $\mu$ F.

Where:

$\Delta V_{OS}$  = The allowable amount of overshoot voltage in load transition

$\Delta V_{US}$  = The allowable amount of undershoot voltage in load transition

$T_{min(off)}$  = Minimum off time

**9.2.2.3 Choose Input Capacitor**

The TPS53114 requires an input decoupling capacitor and a bulk capacitor is needed depending on the application. A minimum 10- $\mu$ F high-quality ceramic capacitor is recommended for the input capacitor. The capacitor voltage rating needs to be greater than the maximum input voltage.

**9.2.2.4 Choose Bootstrap Capacitor**

The TPS53114 requires a bootstrap capacitor from SW to VBST to provide the floating supply for the high-side drivers. A minimum 0.1- $\mu$ F high-quality ceramic capacitor is recommended. The voltage rating should be greater than 10.0 V.

**9.2.2.5 Choose VREG5 and V5FILT Capacitors**

The TPS53114 requires both the VREG5 regulator and V5FILT input are bypassed. A minimum 4.7- $\mu$ F high-quality ceramic capacitor must be connected between the VREG5 and GND for proper operation. A minimum 1.0- $\mu$ F high-quality ceramic capacitor must be connected between the V5FILT and GND for proper operation. Both of these capacitors' voltage ratings should be greater than 10 V.

**9.2.2.6 Choose Output Voltage Set Point Resistors**

The output voltage is set with a resistor divider from output voltage node to the VFBx pin. It is recommended to use 1% tolerance or better resistors. Select R2 between 10 k $\Omega$  and 100 k $\Omega$  and use [Equation 11](#) or [Equation 12](#) to calculate R1.

$$R1 = \left( \frac{V_o1}{0.765 + \frac{VFB1_{(ripple)}}{2}} - 1 \right) \cdot R2 \quad (\text{FSEL} = \text{GND}) \quad (11)$$

$$R1 = \left( \frac{V_o1}{0.758 + \frac{VFB1_{(ripple)}}{2}} - 1 \right) \cdot R2 \quad (\text{FSEL} = \text{V5FILT}) \quad (12)$$

Where:

$VFB1_{(ripple)}$  = Ripple voltage at VFB1

### 9.2.2.7 Choose Over Current Set Point Resistor

$$V_{TRIP} = \left( I_{OCL} - \frac{(V_{IN} - V_O)}{2 \cdot L1 \cdot f_{sw}} \cdot \frac{V_O}{V_{IN}} \right) \cdot R_{DS(ON)} \quad (13)$$

$$R_{TRIP} \text{ (k}\Omega\text{)} = \frac{V_{TRIP} \text{ (mV)} - V_{OCLoff}}{I_{TRIP} \text{ (}\mu\text{A)}} \quad (14)$$

Where:

$R_{DS(ON)}$  = Low side FET on-resistance

$I_{TRIP}$  = TRIP pin source current (  $\neq 10 \mu\text{A}$  )

$V_{OCLoff}$  = Minimum over current limit offset voltage (-20 mV)

$I_{OCL}$  = over current limit

### 9.2.2.8 Choose Soft Start Capacitor

Soft start timing equations are as follows:

$$T_{SS} = \frac{C_7 \cdot 0.765}{2e^{-6}} \text{ (s)} \quad (\text{FSEL} = \text{GND}) \quad (15)$$

$$T_{SS} = \frac{C_7 \cdot 0.758}{2e^{-6}} \text{ (s)} \quad (\text{FSEL} = \text{V5FILT}) \quad (16)$$

### 9.2.2.9 Choose Package Option

TPS53114 power dissipation:

$$P_d = f_{sw} \cdot (C_{iH} + C_{iL}) \cdot V_{REG5} \cdot V_{in(max)} \quad (17)$$

Where:

$C_{iH}$  = Input capacitor of high side MOSFET

$C_{iL}$  = Input capacitor of low side MOSFET

Choose package considering the Dissipation Rating table.

### 9.2.3 350 kHz Application Curves

The application curves of [Figure 13](#) and [Figure 14](#) apply to both the circuits of [700 kHz Operation Application](#) and [350-kHz Operation Application](#).

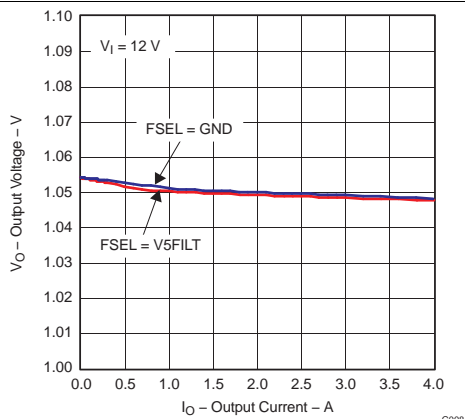

Figure 13. 1.05-V Output Voltage vs. Output Current

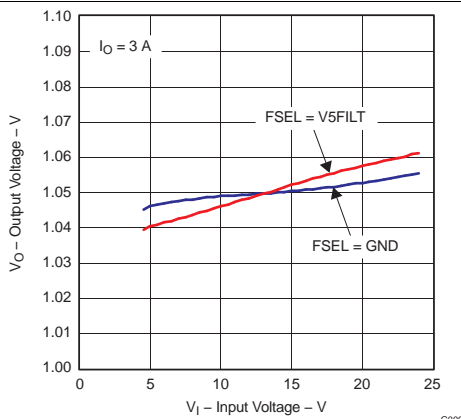

Figure 14. 1.05-V Output Voltage vs. Input Voltage

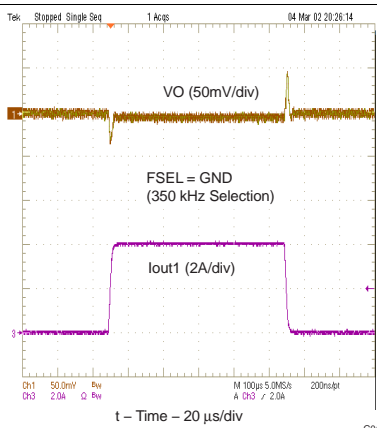

Figure 15. 1.05-V Load Transient Response

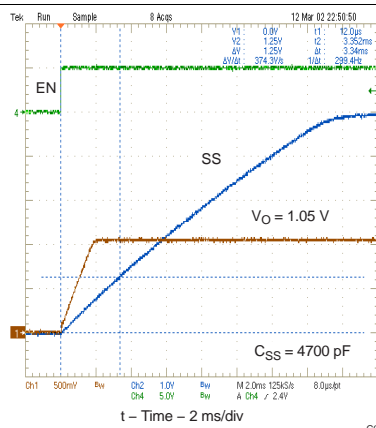

Figure 16. Startup Waveform

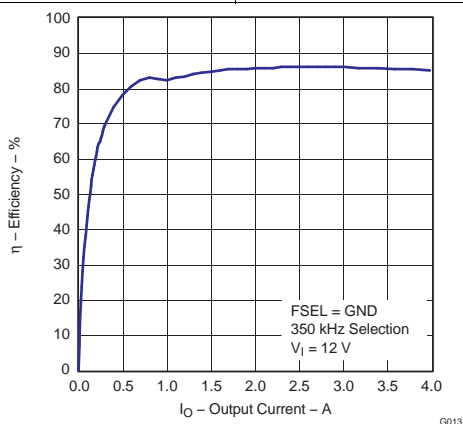

Figure 17. 1.05-V Efficiency vs. Output Current

### 9.3 700 kHz Operation Application

The schematic of Figure 18 shows a typical 700 kHz application schematic. The 700 kHz switching frequency is selected by connecting FSEL to the V5FILT pin. The input voltage is 12 V and the output voltage is 1.05 V.

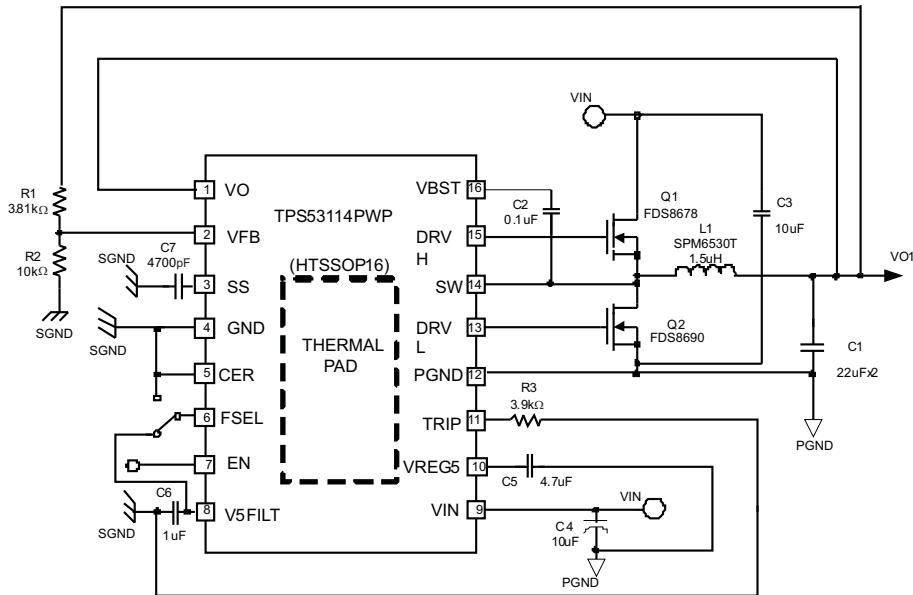

Figure 18. Typical Application Circuit at 700-kHz Switching Frequency Selection (FSEL pin = V5FILT)

#### 9.3.1 Design Requirements

Table 2. Design Parameters

PARAMETERS	EXAMPLE VALUES
Input voltage	12 V
Output voltage	1.05 V
Output current	4 A
Switching frequency	700 kHz

#### 9.3.2 Detailed Design Procedure

For the Detailed Design Procedure, refer to [Detailed Design Procedure](#).

#### 9.3.3 700 kHz Application Curves

The application curves of [Figure 13](#) and [Figure 14](#) apply to both the circuits of [700 kHz Operation Application](#) and [350-kHz Operation Application](#).

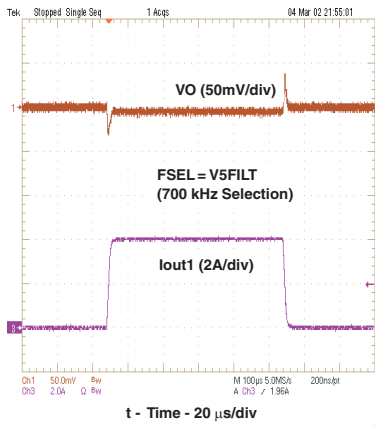

Figure 19. 1.05-V Load Transient Response

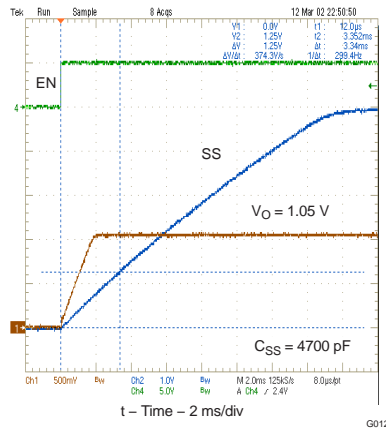

Figure 20. Startup Waveform

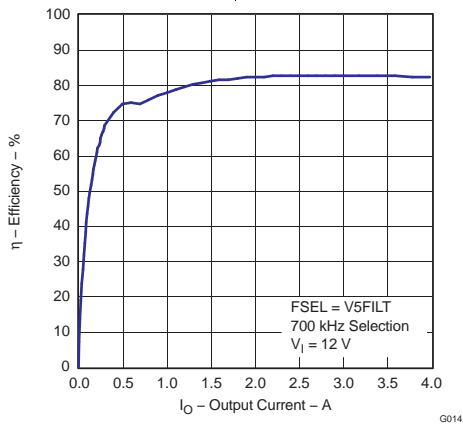

Figure 21. 1.05-V Efficiency vs. Output Current

## 10 Power Supply Recommendations

The TPS53114 is designed to operate from an input voltage supply range between 4.5 V and 24 V. This input supply must be well regulated. If the input supply is located more than a few inches from the TPS53114 device additional 0.1  $\mu\text{F}$  ceramic capacitance may be required in addition to the ceramic bypass capacitors, 10  $\mu\text{F}$ .

## 11 Layout

### 11.1 Layout Guidelines

- Keep the input switching current loop as small as possible.
- Place the input capacitor (C3) close to the top switching FET.
- Place the input capacitor (C4) close to the IC VIN pin.
- The output current loop should also be kept as small as possible.
- Keep the SW node as physically small and short as possible as to minimize parasitic capacitance and inductance and to minimize radiated emissions.
- Independent connections should be brought from the output to the feedback pin (VFB) and VO pin of the device.
- Keep analog and non-switching components away from switching components.
- Terminate the feedback resistor divider (R2), slow start capacitor C7), CER pin, V5FILT capacitor (C6) and TRIP resistor (R3) to signal ground (SGND).
- Connect the signal ground (SGND) copper area to the GND pin at the GND pin.
- Make a single point connection from the signal ground to power ground directly under the IC as shown.
- Do not allow switching current to flow under the device.

### 11.2 Layout Example

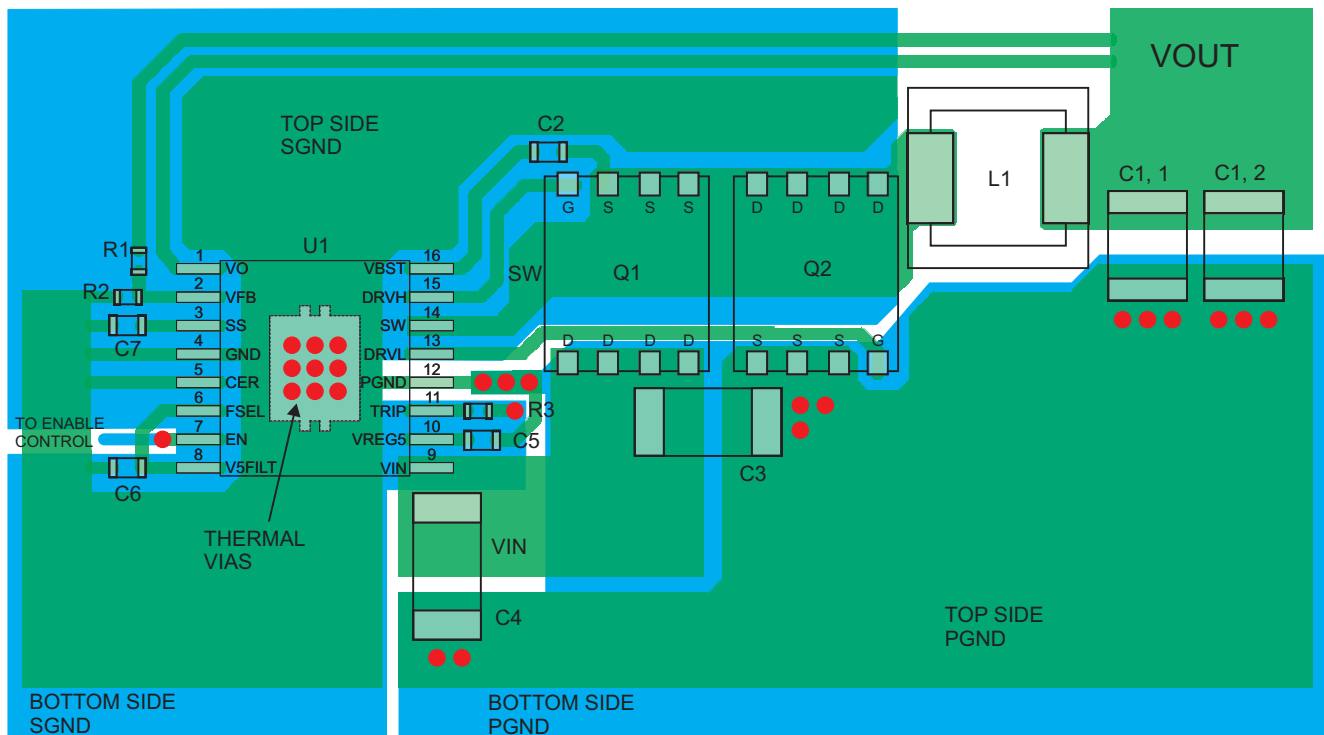

VIAS  
 TOP SIDE ETCH  
 BOTTOM SIDE ETCH  
 COMPONENT PADS

**Figure 22. Typical TPS53114 Layout**



## 12 Device and Documentation Support

### 12.1 Trademarks

D-CAP2 is a trademark of Texas Instruments.

### 12.2 Electrostatic Discharge Caution



These devices have limited built-in ESD protection. The leads should be shorted together or the device placed in conductive foam during storage or handling to prevent electrostatic damage to the MOS gates.

### 12.3 Glossary

[SLYZ022](#) — *TI Glossary*.

This glossary lists and explains terms, acronyms, and definitions.

## 13 Mechanical, Packaging, and Orderable Information

The following pages include mechanical, packaging, and orderable information. This information is the most current data available for the designated devices. This data is subject to change without notice and revision of this document. For browser-based versions of this data sheet, refer to the left-hand navigation.

**PACKAGING INFORMATION**

Orderable Device	Status (1)	Package Type	Package Drawing	Pins	Package Qty	Eco Plan (2)	Lead finish/ Ball material (6)	MSL Peak Temp (3)	Op Temp (°C)	Device Marking (4/5)	Samples
TPS53114PW	ACTIVE	TSSOP	PW	16	90	RoHS & Green	NIPDAU	Level-1-260C-UNLIM	-40 to 85	PS53114	<a href="#">Samples</a>
TPS53114PWP	LIFEBUY	HTSSOP	PWP	16	90	RoHS & Green	NIPDAU	Level-2-260C-1 YEAR	-40 to 85	PS53114	
TPS53114PWPR	ACTIVE	HTSSOP	PWP	16	2000	RoHS & Green	NIPDAU	Level-2-260C-1 YEAR	-40 to 85	PS53114	<a href="#">Samples</a>
TPS53114PWR	ACTIVE	TSSOP	PW	16	2000	RoHS & Green	NIPDAU	Level-1-260C-UNLIM	-40 to 85	PS53114	<a href="#">Samples</a>

(1) The marketing status values are defined as follows:

**ACTIVE:** Product device recommended for new designs.

**LIFEBUY:** TI has announced that the device will be discontinued, and a lifetime-buy period is in effect.

**NRND:** Not recommended for new designs. Device is in production to support existing customers, but TI does not recommend using this part in a new design.

**PREVIEW:** Device has been announced but is not in production. Samples may or may not be available.

**OBSELETE:** TI has discontinued the production of the device.

(2) **RoHS:** TI defines "RoHS" to mean semiconductor products that are compliant with the current EU RoHS requirements for all 10 RoHS substances, including the requirement that RoHS substance do not exceed 0.1% by weight in homogeneous materials. Where designed to be soldered at high temperatures, "RoHS" products are suitable for use in specified lead-free processes. TI may reference these types of products as "Pb-Free".

**RoHS Exempt:** TI defines "RoHS Exempt" to mean products that contain lead but are compliant with EU RoHS pursuant to a specific EU RoHS exemption.

**Green:** TI defines "Green" to mean the content of Chlorine (Cl) and Bromine (Br) based flame retardants meet JS709B low halogen requirements of <=1000ppm threshold. Antimony trioxide based flame retardants must also meet the <=1000ppm threshold requirement.

(3) MSL, Peak Temp. - The Moisture Sensitivity Level rating according to the JEDEC industry standard classifications, and peak solder temperature.

(4) There may be additional marking, which relates to the logo, the lot trace code information, or the environmental category on the device.

(5) Multiple Device Markings will be inside parentheses. Only one Device Marking contained in parentheses and separated by a "~" will appear on a device. If a line is indented then it is a continuation of the previous line and the two combined represent the entire Device Marking for that device.

(6) Lead finish/Ball material - Orderable Devices may have multiple material finish options. Finish options are separated by a vertical ruled line. Lead finish/Ball material values may wrap to two lines if the finish value exceeds the maximum column width.

**Important Information and Disclaimer:**The information provided on this page represents TI's knowledge and belief as of the date that it is provided. TI bases its knowledge and belief on information provided by third parties, and makes no representation or warranty as to the accuracy of such information. Efforts are underway to better integrate information from third parties. TI has taken and continues to take reasonable steps to provide representative and accurate information but may not have conducted destructive testing or chemical analysis on incoming materials and chemicals. TI and TI suppliers consider certain information to be proprietary, and thus CAS numbers and other limited information may not be available for release.

In no event shall TI's liability arising out of such information exceed the total purchase price of the TI part(s) at issue in this document sold by TI to Customer on an annual basis.

**TAPE AND REEL INFORMATION**

**QUADRANT ASSIGNMENTS FOR PIN 1 ORIENTATION IN TAPE**

\*All dimensions are nominal

Device	Package Type	Package Drawing	Pins	SPQ	Reel Diameter (mm)	Reel Width W1 (mm)	A0 (mm)	B0 (mm)	K0 (mm)	P1 (mm)	W (mm)	Pin1 Quadrant
TPS53114PWPR	HTSSOP	PWP	16	2000	330.0	12.4	6.9	5.6	1.6	8.0	12.0	Q1
TPS53114PWR	TSSOP	PW	16	2000	330.0	12.4	6.9	5.6	1.6	8.0	12.0	Q1

**TAPE AND REEL BOX DIMENSIONS**

\*All dimensions are nominal

Device	Package Type	Package Drawing	Pins	SPQ	Length (mm)	Width (mm)	Height (mm)
TPS53114PWPR	HTSSOP	PWP	16	2000	356.0	356.0	35.0
TPS53114PWR	TSSOP	PW	16	2000	356.0	356.0	35.0

**TUBE**

\*All dimensions are nominal

Device	Package Name	Package Type	Pins	SPQ	L (mm)	W (mm)	T (μm)	B (mm)
TPS53114PW	PW	TSSOP	16	90	530	10.2	3600	3.5
TPS53114PWP	PWP	HTSSOP	16	90	530	10.2	3600	3.5



4220204/A 02/2017

NOTES:

1. All linear dimensions are in millimeters. Any dimensions in parenthesis are for reference only. Dimensioning and tolerancing per ASME Y14.5M.
2. This drawing is subject to change without notice.
3. This dimension does not include mold flash, protrusions, or gate burrs. Mold flash, protrusions, or gate burrs shall not exceed 0.15 mm per side.
4. This dimension does not include interlead flash. Interlead flash shall not exceed 0.25 mm per side.
5. Reference JEDEC registration MO-153.

# EXAMPLE BOARD LAYOUT

PW0016A

TSSOP - 1.2 mm max height

SMALL OUTLINE PACKAGE



LAND PATTERN EXAMPLE  
EXPOSED METAL SHOWN  
SCALE: 10X



SOLDER MASK DETAILS

4220204/A 02/2017

NOTES: (continued)

- 6. Publication IPC-7351 may have alternate designs.
- 7. Solder mask tolerances between and around signal pads can vary based on board fabrication site.

# EXAMPLE STENCIL DESIGN

PW0016A

TSSOP - 1.2 mm max height

SMALL OUTLINE PACKAGE



SOLDER PASTE EXAMPLE  
BASED ON 0.125 mm THICK STENCIL  
SCALE: 10X

4220204/A 02/2017

NOTES: (continued)

8. Laser cutting apertures with trapezoidal walls and rounded corners may offer better paste release. IPC-7525 may have alternate design recommendations.
9. Board assembly site may have different recommendations for stencil design.

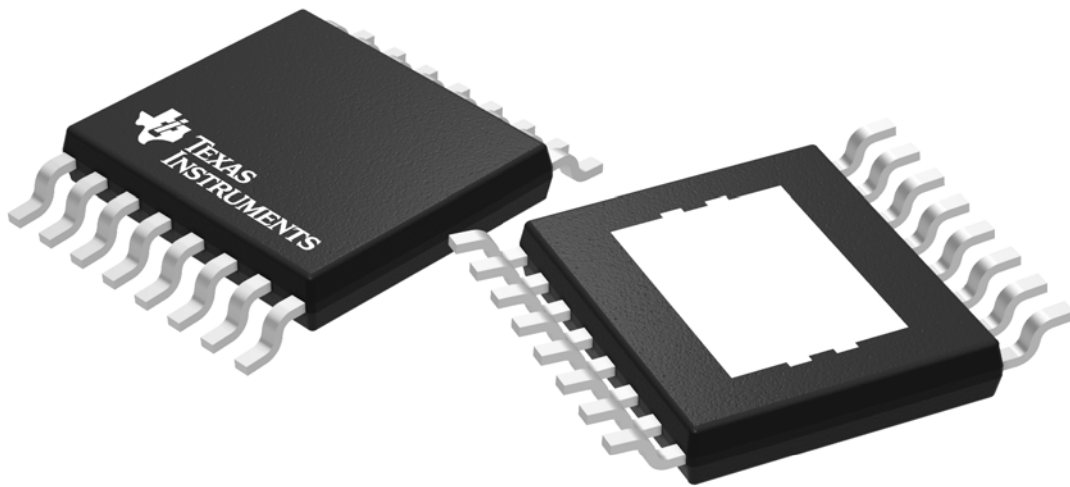

Images above are just a representation of the package family, actual package may vary.  
Refer to the product data sheet for package details.

# PWP0016C

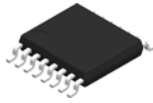

# PACKAGE OUTLINE

## PowerPAD™ TSSOP - 1.2 mm max height

SMALL OUTLINE PACKAGE

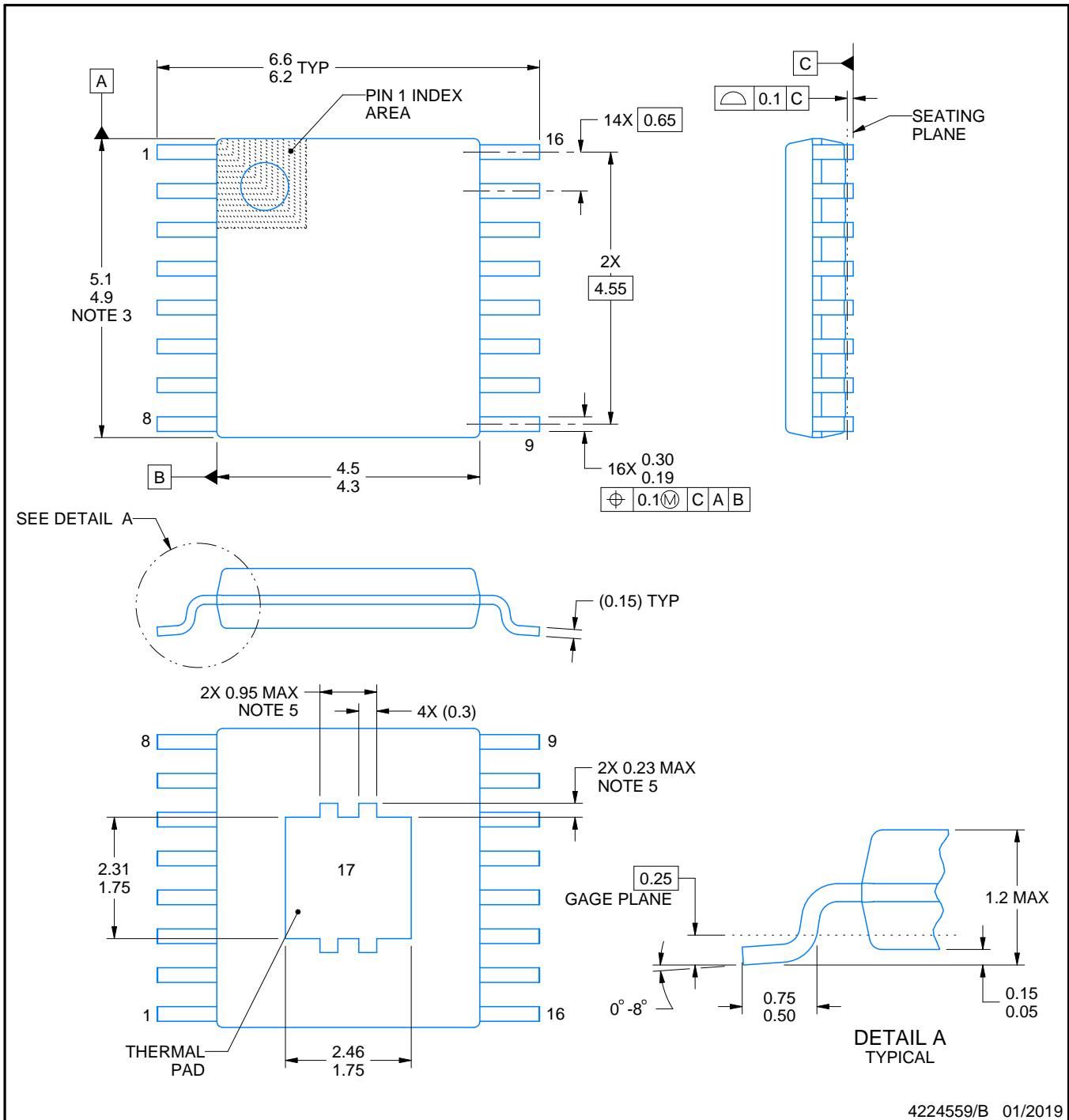

### NOTES:

PowerPAD is a trademark of Texas Instruments.

1. All linear dimensions are in millimeters. Any dimensions in parenthesis are for reference only. Dimensioning and tolerancing per ASME Y14.5M.
2. This drawing is subject to change without notice.
3. This dimension does not include mold flash, protrusions, or gate burrs. Mold flash, protrusions, or gate burrs shall not exceed 0.15 mm per side.
4. Reference JEDEC registration MO-153.
5. Features may differ or may not be present.



# EXAMPLE STENCIL DESIGN

PWP0016C

PowerPAD™ TSSOP - 1.2 mm max height

SMALL OUTLINE PACKAGE

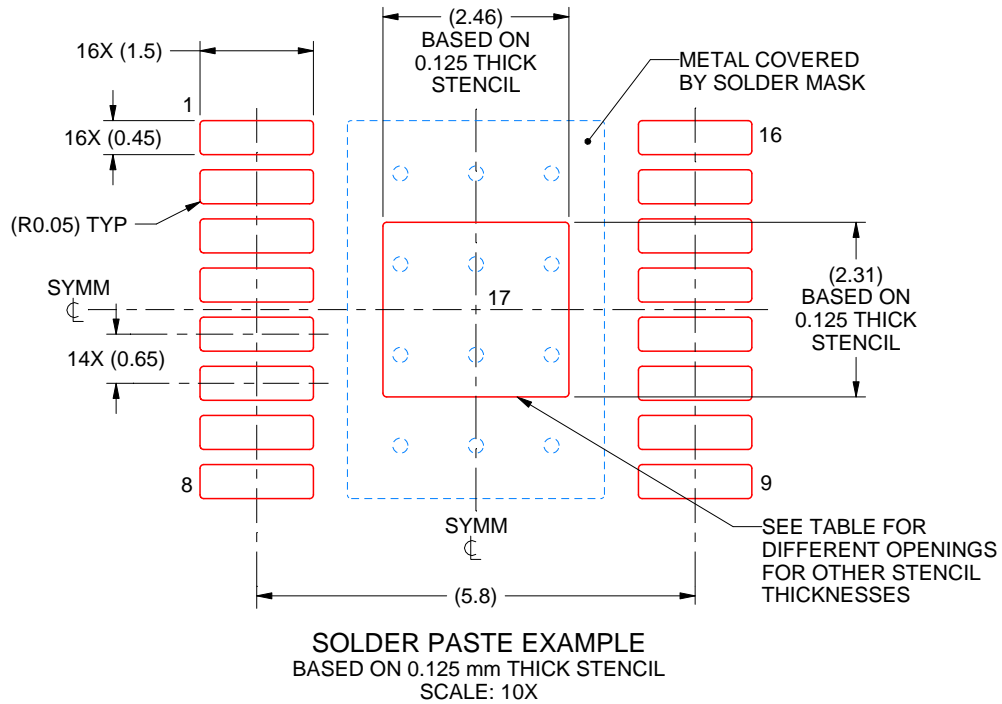

STENCIL THICKNESS	SOLDER STENCIL OPENING
0.1	2.75 X 2.58
0.125	2.46 X 2.31 (SHOWN)
0.15	2.25 X 2.11
0.175	2.08 X 1.95

4224559/B 01/2019

NOTES: (continued)

11. Laser cutting apertures with trapezoidal walls and rounded corners may offer better paste release. IPC-7525 may have alternate design recommendations.
12. Board assembly site may have different recommendations for stencil design.

## IMPORTANT NOTICE AND DISCLAIMER

TI PROVIDES TECHNICAL AND RELIABILITY DATA (INCLUDING DATA SHEETS), DESIGN RESOURCES (INCLUDING REFERENCE DESIGNS), APPLICATION OR OTHER DESIGN ADVICE, WEB TOOLS, SAFETY INFORMATION, AND OTHER RESOURCES "AS IS" AND WITH ALL FAULTS, AND DISCLAIMS ALL WARRANTIES, EXPRESS AND IMPLIED, INCLUDING WITHOUT LIMITATION ANY IMPLIED WARRANTIES OF MERCHANTABILITY, FITNESS FOR A PARTICULAR PURPOSE OR NON-INFRINGEMENT OF THIRD PARTY INTELLECTUAL PROPERTY RIGHTS.

These resources are intended for skilled developers designing with TI products. You are solely responsible for (1) selecting the appropriate TI products for your application, (2) designing, validating and testing your application, and (3) ensuring your application meets applicable standards, and any other safety, security, regulatory or other requirements.

These resources are subject to change without notice. TI grants you permission to use these resources only for development of an application that uses the TI products described in the resource. Other reproduction and display of these resources is prohibited. No license is granted to any other TI intellectual property right or to any third party intellectual property right. TI disclaims responsibility for, and you will fully indemnify TI and its representatives against, any claims, damages, costs, losses, and liabilities arising out of your use of these resources.

TI's products are provided subject to [TI's Terms of Sale](#) or other applicable terms available either on [ti.com](https://www.ti.com) or provided in conjunction with such TI products. TI's provision of these resources does not expand or otherwise alter TI's applicable warranties or warranty disclaimers for TI products.

TI objects to and rejects any additional or different terms you may have proposed.

Mailing Address: Texas Instruments, Post Office Box 655303, Dallas, Texas 75265  
Copyright © 2024, Texas Instruments Incorporated

## Looking for pricing, stock, or lifecycle information?

Click below to explore more details on WIN SOURCE:

 [View TPS53114PWPR on WIN SOURCE](#)

 [Texas Instruments](#) Information

## Optimize Your Supply Chain with WIN SOURCE Solutions

-  Global Sourcing Solution
-  Obsolete Management
-  Cost Control Management
-  Shortage Management
-  Alternative Solution
-  Excess Inventory Management