



**THE DATASHEET OF
TPS54060DGQ**



TPS54060 0.5-A, 60-V Step Down DC-DC Converter with Eco-Mode™

1 Features

- 3.5-V to 60-V Input Voltage Range
- 200-mΩ High-Side MOSFET
- High Efficiency at Light Loads with a Pulse Skipping Eco-Mode™
- 116-μA Operating Quiescent Current
- 1.3-μA Shutdown Current
- 100-kHz to 2.5-MHz Switching Frequency
- Synchronizes to External Clock
- Adjustable Slow Start and Sequencing
- UV and OV Power Good Output
- Adjustable UVLO Voltage and Hysteresis
- 0.8-V Internal Voltage Reference
- 10-Pin HVSSOP With PowerPAD™ Package and 3-mm × 3-mm 10-Pin VSON Package
- Supported by WEBENCH™ and SwitcherPro™ Software Tool

2 Applications

- 12-V, 24-V, and 48-V Industrial and Commercial Low Power Systems
- Aftermarket Auto Accessories: Video, GPS, Entertainment

3 Description

The TPS54060 device is a 60-V, 0.5-A, step-down regulator with an integrated high-side MOSFET. Current-mode control provides simple external compensation and flexible component selection. A low ripple pulse skip mode reduces the no load, regulated output supply current to 116 μA. Using the enable pin, shutdown supply current is reduced to 1.3 μA, when the enable pin is low.

VIN undervoltage lockout is internally set at 2.5 V, but can be increased using the enable pin. The output voltage startup ramp is controlled by the slow start pin that can also be configured for sequencing/tracking. An open-drain power good signal indicates the output is within 94% to 107% of its nominal voltage.

A wide switching frequency range allows efficiency and external component size to be optimized. Frequency fold back and thermal shutdown protects the part during an overload condition.

The TPS54060 is available in 10-pin thermally enhanced HVSSOP PowerPAD™ package and 10-pin 3-mm × 3-mm VSON package.

Device Information⁽¹⁾

PART NUMBER	PACKAGE	BODY SIZE (NOM)
TPS54060	VSON (10)	3.00 mm × 3.00 mm
	HVSSOP (10)	3.00 mm × 3.00 mm

(1) For all available packages, see the orderable addendum at the end of the data sheet.

Simplified Schematic

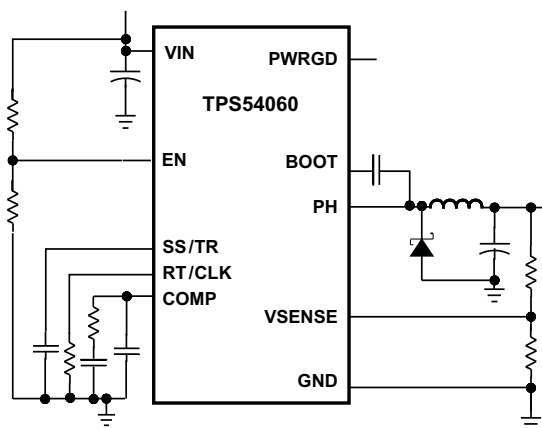

Efficiency vs Load Current

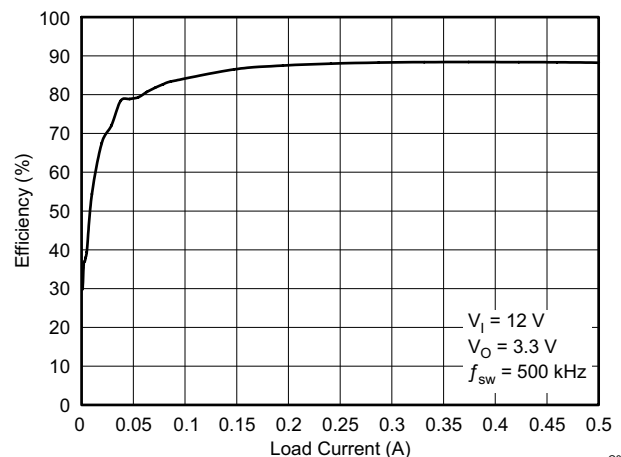

C033



Table of Contents

1 Features	1	7.2 Functional Block Diagram	12
2 Applications	1	7.3 Feature Description	12
3 Description	1	7.4 Device Functional Modes	20
4 Revision History	2	8 Application and Implementation	22
5 Pin Configuration and Functions	3	8.1 Application Information	22
6 Specifications	4	8.2 Typical Applications	30
6.1 Absolute Maximum Ratings	4	9 Power Supply Recommendations	40
6.2 ESD Ratings	4	10 Layout	41
6.3 Recommended Operating Conditions	4	10.1 Layout Guidelines	41
6.4 Thermal Information	5	10.2 Layout Example	41
6.5 Electrical Characteristics	5	11 Device and Documentation Support	42
6.6 Timing Resistor and External Clock (RT/CLK Pin) Timing Requirements	6	11.1 Device Support	42
6.7 Timing Resistor and External Clock (RT/CLK PIN) Switching Characteristics	6	11.2 Documentation Support	42
6.8 Typical Characteristics	7	11.3 Trademarks	42
7 Detailed Description	11	11.4 Electrostatic Discharge Caution	42
7.1 Overview	11	11.5 Glossary	42
		12 Mechanical, Packaging, and Orderable Information	42

4 Revision History

NOTE: Page numbers for previous revisions may differ from page numbers in the current version.

Changes from Revision B (January 2014) to Revision C	Page
<ul style="list-style-type: none"> Added ESD Ratings table, Feature Description section, Device Functional Modes, Application and Implementation section, Power Supply Recommendations section, Layout section, Device and Documentation Support section, and Mechanical, Packaging, and Orderable Information section. 	1

Changes from Revision A (July 2010) to Revision B	Page
<ul style="list-style-type: none"> Deleted SWIFT from the data sheet Title and Features 	1

Changes from Original (January 2009) to Revision A	Page
<ul style="list-style-type: none"> Added the DRC package option to the Features and Description. Added the DRC Pin Configuration Replaced the PACKAGE DISSIPATION RATINGS table with the Thermal Information Table Updated Figure 63 Added Figure 64 	1 3 5 39 40

5 Pin Configuration and Functions

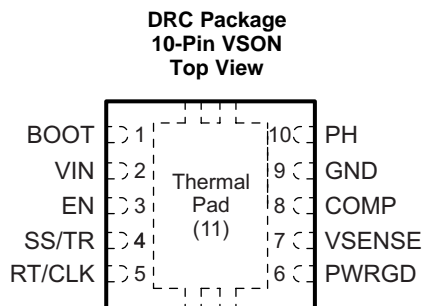
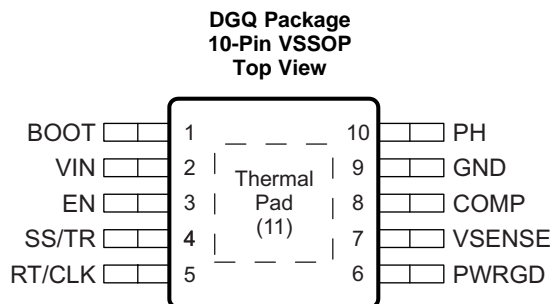

Pin Functions

PIN		I/O	DESCRIPTION
NAME	NO.		
BOOT	1	I	A bootstrap capacitor is required between BOOT and PH. If the voltage on this capacitor is below the minimum required by the integrated gate driver for the high-side power MOSFET, the output is forced to switch off until the capacitor is refreshed.
COMP	8	I	Error amplifier output and input to the output switch current comparator. Connect frequency compensation components to this pin.
EN	3	I	Enable pin, internal pull-up current source. Pull below 1.2V to disable. Float to enable. Adjust the input undervoltage lockout with resistor divider.
GND	9	–	Ground
PH	10	O	The source of the internal high-side power MOSFET.
Thermal pad	11	–	GND pin must be electrically connected to the exposed pad on the printed circuit board for proper operation.
PWRGD	6	O	An open drain output, asserts low if output voltage is low due to thermal shutdown, dropout, over-voltage or EN shut down.
RT/CLK	5	I	Resistor Timing and External Clock. An internal amplifier holds this pin at a fixed voltage when using an external resistor to ground to set the switching frequency. If the pin is pulled above the PLL upper threshold, a mode change occurs and the pin becomes a synchronization input. The internal amplifier is disabled and the pin is a high impedance clock input to the internal PLL. If clocking edges stop, the internal amplifier is re-enabled and the mode returns to a resistor set function.
SS/TR	4	I	Slow-start and Tracking. An external capacitor connected to this pin sets the output rise time. Since the voltage on this pin overrides the internal reference, it can be used for tracking and sequencing.
VIN	2	I	Input supply voltage, 3.5 V to 60 V.
VSENSE	7	I	Inverting node of the transconductance (gm) error amplifier.

6 Specifications

6.1 Absolute Maximum Ratings⁽¹⁾

Over operating temperature range (unless otherwise noted).

		MIN	MAX	UNIT
Voltage	VIN	-0.3	65	V
	EN	-0.3	5	
	VSENSE	-0.3	3	
	COMP	-0.3	3	
	PWRGD	-0.3	6	
	SS/TR	-0.3	3	
	RT/CLK	-0.3	3.6	
	BOOT-PH	-0.3	8	
	PH	-0.6	65	
	PH, 10-ns Transient	-2	65	
Voltage Difference	Thermal PAD to GND		±200	mV
Source current	EN		100	µA
	BOOT		100	mA
	VSENSE		10	µA
	PH		Current Limit	A
	RT/CLK		100	µA
Sink current	VIN		Current Limit	A
	COMP		100	µA
	PWRGD		10	mA
	SS/TR		200	µA
Operating junction temperature		-40	150	°C
Storage temperature		-65	150	°C

(1) Stresses beyond those listed under *absolute maximum ratings* may cause permanent damage to the device. These are stress ratings only and functional operation of the device at these or any other conditions beyond those indicated under *recommended operating conditions* is not implied. Exposure to absolute-maximum-rated conditions for extended periods may affect device reliability.

6.2 ESD Ratings

		VALUE	UNIT
V _(ESD)	Electrostatic discharge	Human-body model (HBM), per ANSI/ESDA/JEDEC JS-001 ⁽¹⁾	±1000
		Charged-device model (CDM), per JEDEC specification JESD22-C101 ⁽²⁾	±500

(1) JEDEC document JEP155 states that 500-V HBM allows safe manufacturing with a standard ESD control process.

(2) JEDEC document JEP157 states that 250-V CDM allows safe manufacturing with a standard ESD control process.

6.3 Recommended Operating Conditions

over operating free-air temperature range (unless otherwise noted)

	MIN	MAX	UNIT
Supply input voltage, V _{VIN}	3.5	60	V
Output voltage, V _O	0.8	57	V
Output current, I _O	0	0.5	A
Operating junction temperature, T _J	-40	150	°C

6.4 Thermal Information

THERMAL METRIC ⁽¹⁾⁽²⁾⁽²⁾		TPS54060		UNIT
		DGQ (VSSOP)	DRC (VSON)	
		10 PINS	10 PINS	
R _{θJA}	Junction-to-ambient thermal resistance (standard board)	62.5	40	°C/W
R _{θJA}	Junction-to-ambient thermal resistance (custom board) ⁽³⁾	57	56.5	°C/W
ψ _{JT}	Junction-to-top characterization parameter	1.7	0.6	°C/W
ψ _{JB}	Junction-to-board characterization parameter	20.1	7.5	°C/W
R _{θJC(top)}	Junction-to-case(top) thermal resistance	83	65	°C/W
R _{θJC(bot)}	Junction-to-case(bottom) thermal resistance	21	7.8	°C/W
R _{θJB}	Junction-to-board thermal resistance	28	8	°C/W

- (1) For more information about traditional and new thermal metrics, see the *Semiconductor and IC Package Thermal Metrics* application report, [SPRA953](#).
- (2) Power rating at a specific ambient temperature T_A should be determined with a junction temperature of 150°C. This is the point where distortion starts to substantially increase. See power dissipation estimate in application section of this data sheet for more information.
- (3) Test boards conditions:
 - (a) 3 inches x 3 inches, 2 layers, thickness: 0.062 inch
 - (b) 2 oz. copper traces located on the top of the PCB
 - (c) 2 oz. copper ground plane, bottom layer
 - (d) 6 thermal vias (13mil) located under the device package

6.5 Electrical Characteristics

T_J = –40°C to 150°C, V_{IN} = 3.5 to 60 V (unless otherwise noted)

PARAMETER	TEST CONDITIONS	MIN	TYP	MAX	UNIT
SUPPLY VOLTAGE (VIN PIN)					
Operating input voltage		3.5		60	V
Internal undervoltage lockout threshold	No voltage hysteresis, rising and falling		2.5		V
Shutdown supply current	EN = 0 V, 25°C, 3.5 V ≤ V _{IN} ≤ 60 V		1.3	4	μA
Operating : nonswitching supply current	V _{SENSE} = 0.83 V, V _{IN} = 12 V, 25°C		116	136	
ENABLE AND UVLO (EN PIN)					
Enable threshold voltage	No voltage hysteresis, rising and falling, 25°C	0.9	1.25	1.55	V
Input current	Enable threshold +50 mV		–3.8		μA
	Enable threshold –50 mV		–0.9		
Hysteresis current			–2.9		μA
VOLTAGE REFERENCE					
Voltage reference	T _J = 25°C	0.792	0.8	0.808	V
		0.784	0.8	0.816	
HIGH-SIDE MOSFET					
On-resistance	V _{IN} = 3.5 V, BOOT-PH = 3 V		300		mΩ
	V _{IN} = 12 V, BOOT-PH = 6 V		200	410	
ERROR AMPLIFIER					
Input current			50		nA
Error amplifier transconductance (g _M)	–2 μA < I _{COMP} < 2 μA, V _{COMP} = 1 V		97		μS
Error amplifier transconductance (g _M) during slow start	–2 μA < I _{COMP} < 2 μA, V _{COMP} = 1 V, V _{VSENSE} = 0.4 V		26		μS
Error amplifier dc gain	V _{VSENSE} = 0.8 V		10,000		V/V
Error amplifier bandwidth			2700		kHz
Error amplifier source/sink	V _(COMP) = 1 V, 100 mV overdrive		±7		μA
COMP to switch current transconductance			1.9		A/V
CURRENT LIMIT					

Electrical Characteristics (continued)

 $T_J = -40^{\circ}\text{C}$ to 150°C , $V_{IN} = 3.5$ to 60 V (unless otherwise noted)

PARAMETER		TEST CONDITIONS	MIN	TYP	MAX	UNIT
Current limit threshold		$V_{IN} = 12$ V, $T_J = 25^{\circ}\text{C}$	0.6	0.94		A
THERMAL SHUTDOWN						
Thermal shutdown				182		$^{\circ}\text{C}$
SLOW START AND TRACKING (SS/TR)						
Charge current		$V_{SS/TR} = 0.4$ V		2		μA
SS/TR-to-VSENSE matching		$V_{SS/TR} = 0.4$ V		45		mV
SS/TR-to-reference crossover		98% nominal		1.0		V
SS/TR discharge current (overload)		$V_{SENSE} = 0$ V, $V(\text{SS/TR}) = 0.4$ V		112		μA
SS/TR discharge voltage		$V_{SENSE} = 0$ V		54		mV
POWER GOOD (PWRGD PIN)						
$V_{V_{SENSE}}$	VSENSE threshold	VSENSE falling		92%		
		VSENSE rising		94%		
		VSENSE rising		109%		
		VSENSE falling		107%		
Hysteresis		VSENSE falling		2%		
Output high leakage		$V_{SENSE} = V_{REF}$, $V(\text{PWRGD}) = 5.5$ V, 25°C		10		nA
On resistance		$I(\text{PWRGD}) = 3$ mA, $V_{SENSE} < 0.79$ V		50		Ω
Minimum V_{IN} for defined output		$V(\text{PWRGD}) < 0.5$ V, $I(\text{PWRGD}) = 100$ μA	0.95		1.5	V

6.6 Timing Resistor and External Clock (RT/CLK Pin) Timing Requirements

		MIN	TYP	MAX	UNIT
Minimum CLK input pulse width			40		ns
RT/CLK falling edge to PH rising edge delay			60		ns

6.7 Timing Resistor and External Clock (RT/CLK PIN) Switching Characteristics

over operating free-air temperature range (unless otherwise noted)

PARAMETER		TEST CONDITIONS	MIN	TYP	MAX	UNIT
f_{SW}	Switching frequency	$R_T = 200$ k Ω	450	581	720	kHz
	Switching Frequency Range using RT mode		100		2500	kHz
	Switching frequency range using CLK mode		300		2200	kHz
	PLL lock in time	Measured at 500 kHz		100		μs

6.8 Typical Characteristics

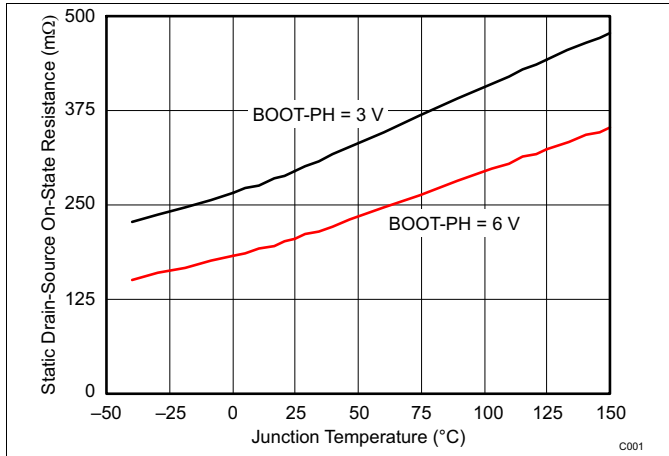

Figure 1. ON Resistance vs Junction Temperature

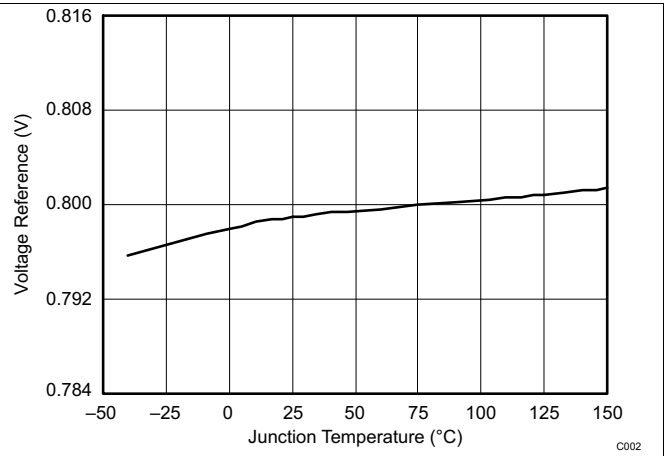

Figure 2. Voltage Reference vs Junction Temperature

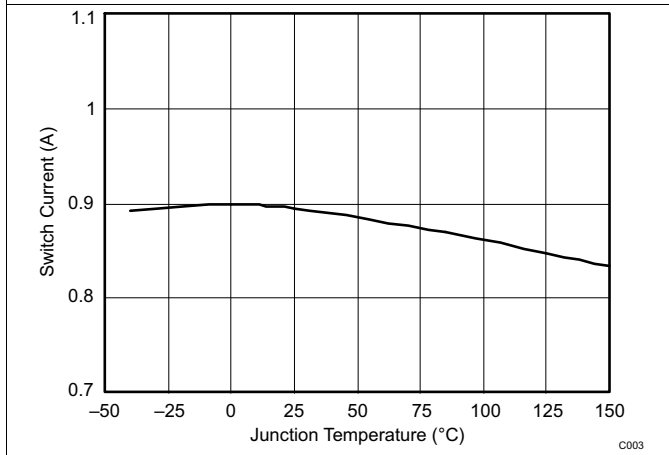

Figure 3. Switch Current Limit vs Junction Temperature

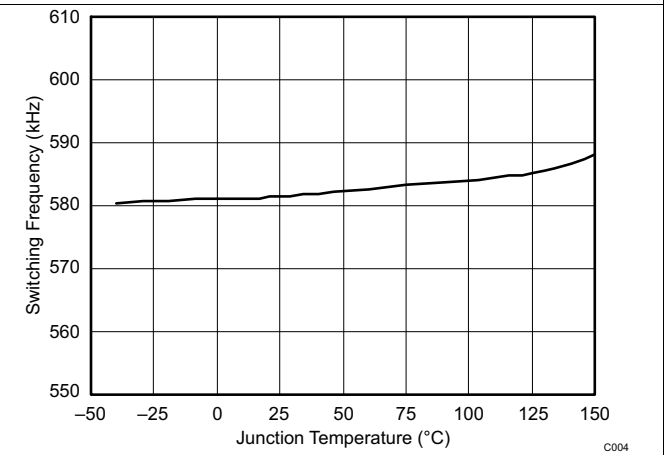

Figure 4. Switching Frequency vs Junction Temperature

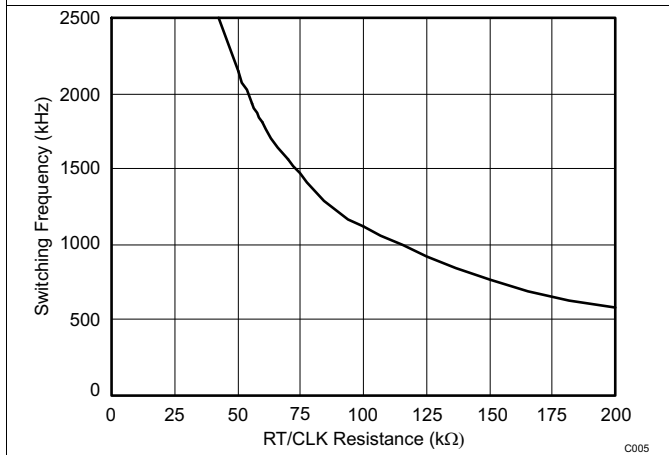

Figure 5. Switching Frequency vs RT/CLK Resistance High Frequency Range

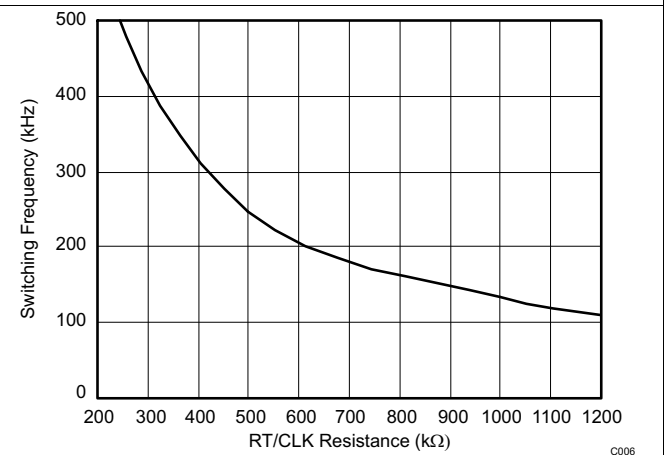
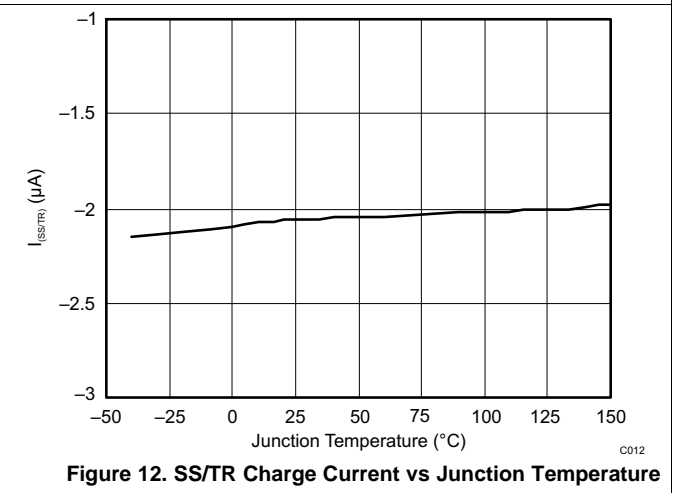
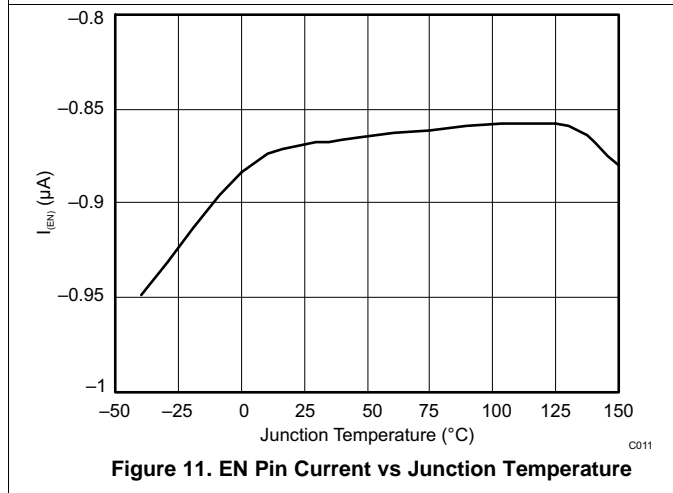
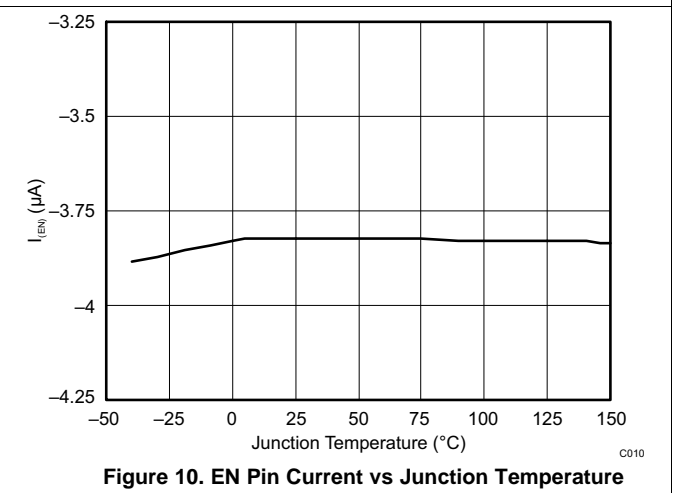
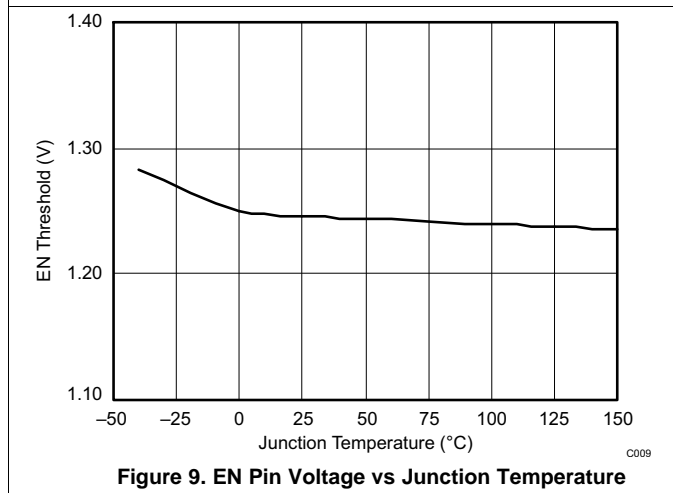
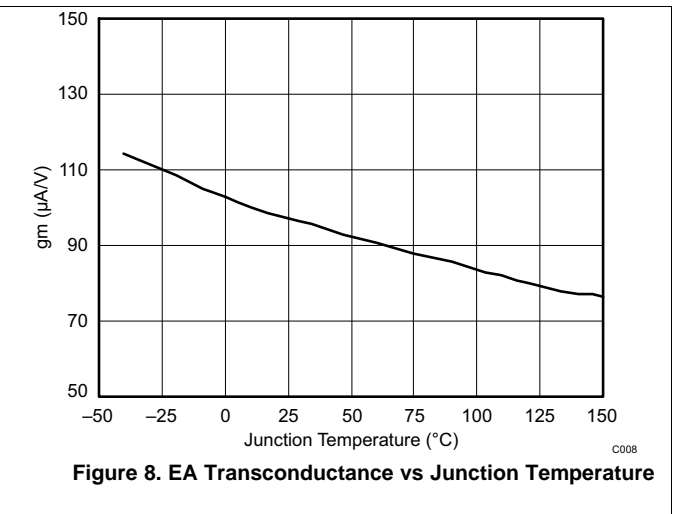
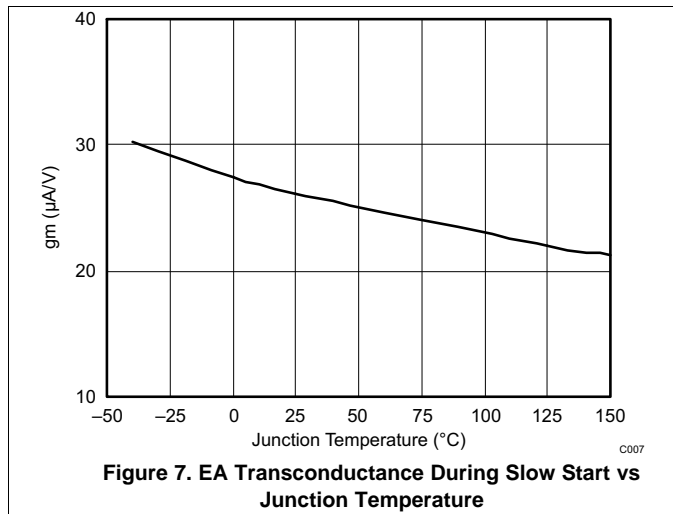
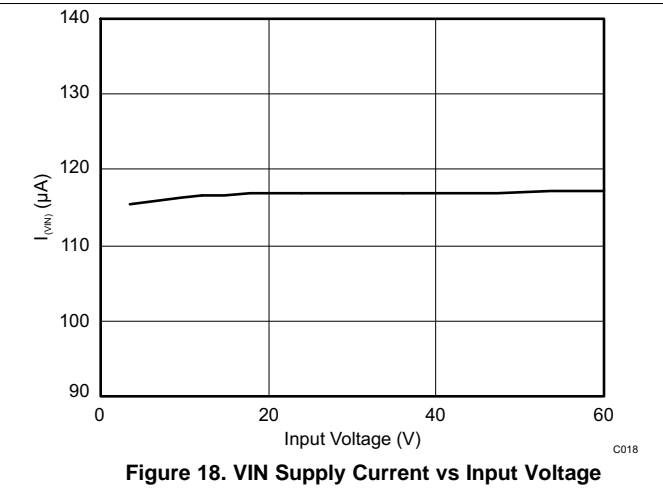
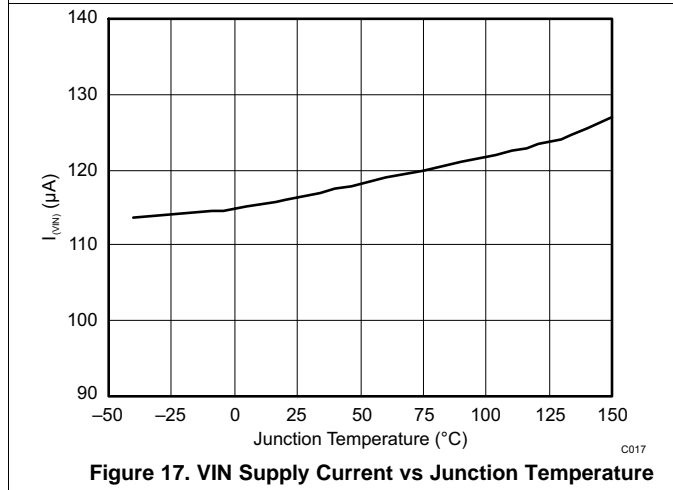
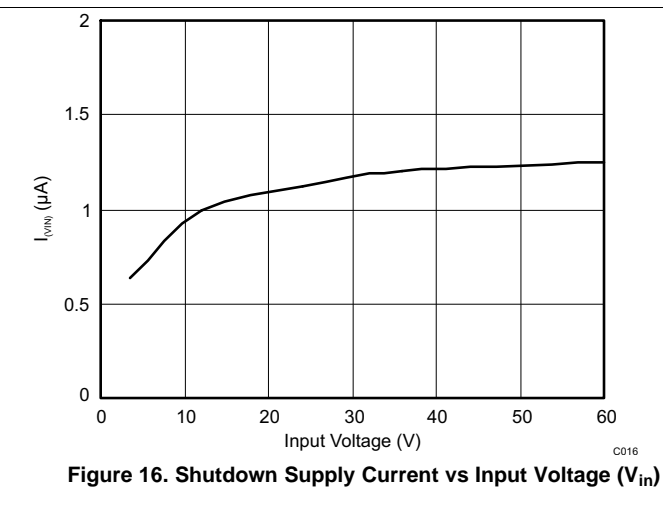
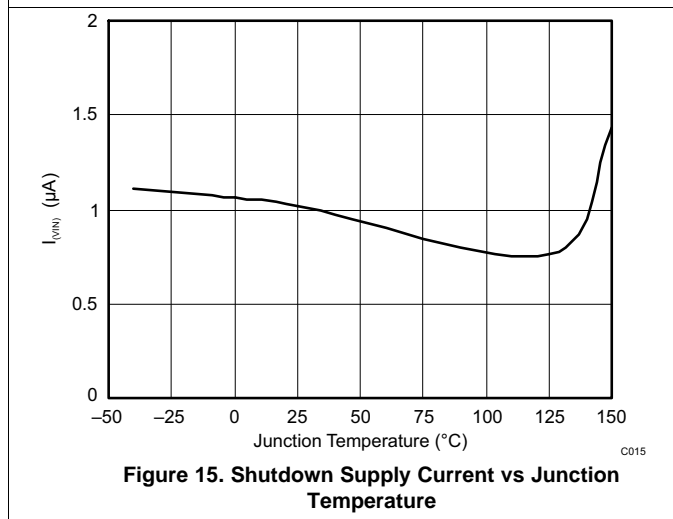
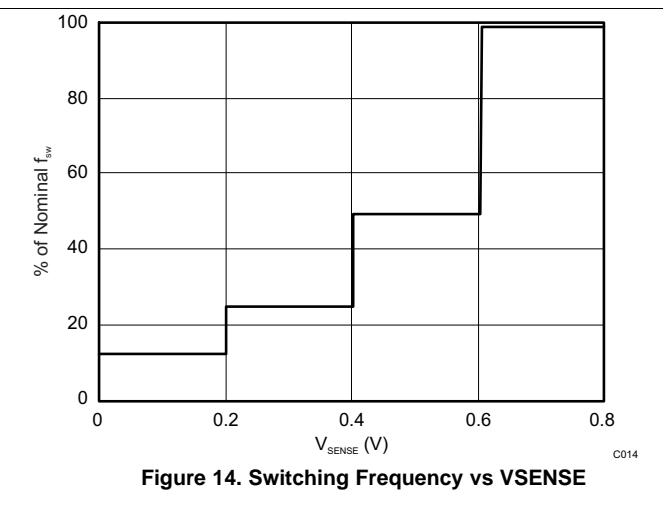
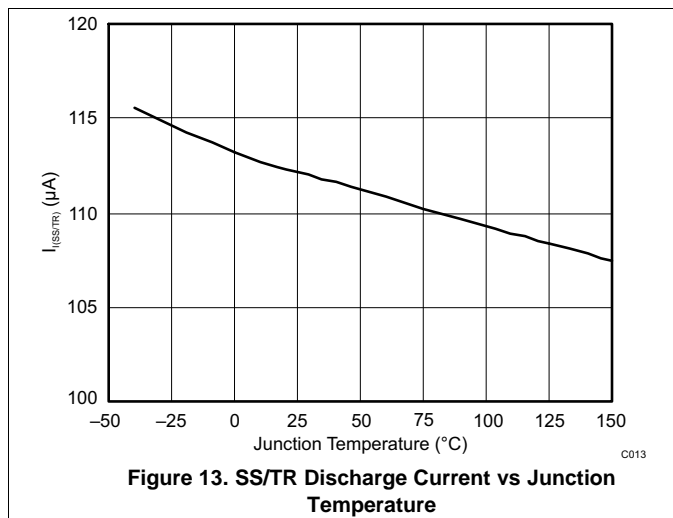

Figure 6. Switching Frequency vs RT/CLK Resistance Low Frequency Range

Typical Characteristics (continued)



Typical Characteristics (continued)



Typical Characteristics (continued)

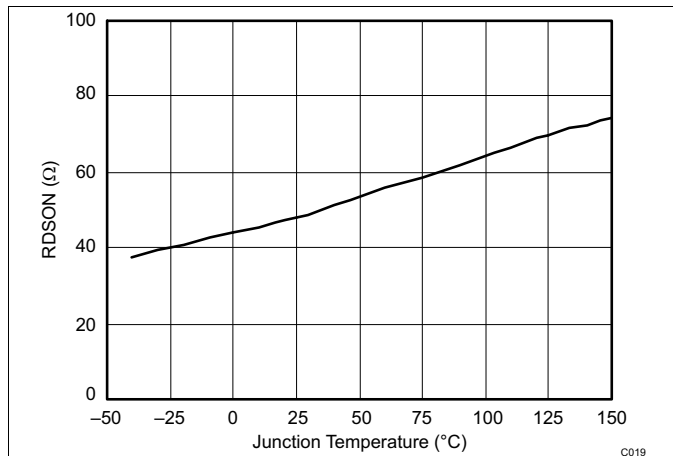

Figure 19. PWRGD ON Resistance vs Junction Temperature

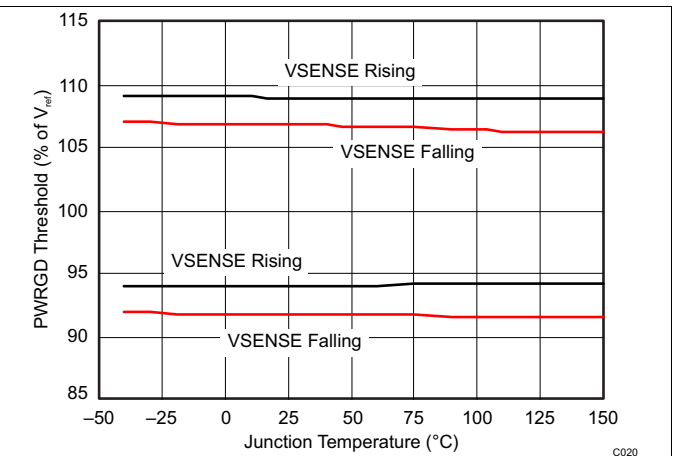

Figure 20. PWRGD Threshold vs Junction Temperature

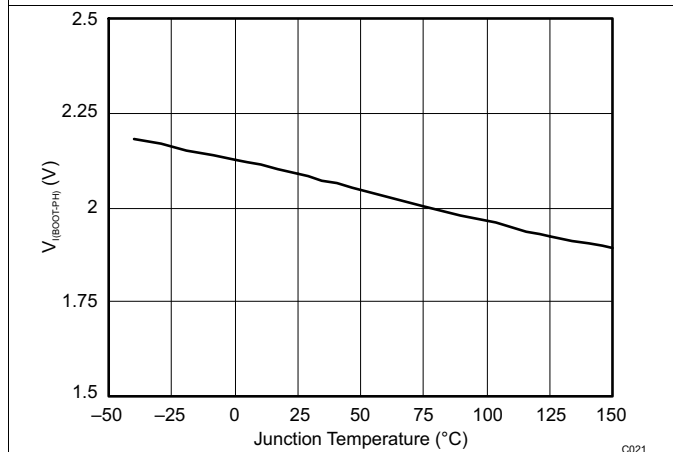

Figure 21. BOOT-PH UVLO vs Junction Temperature

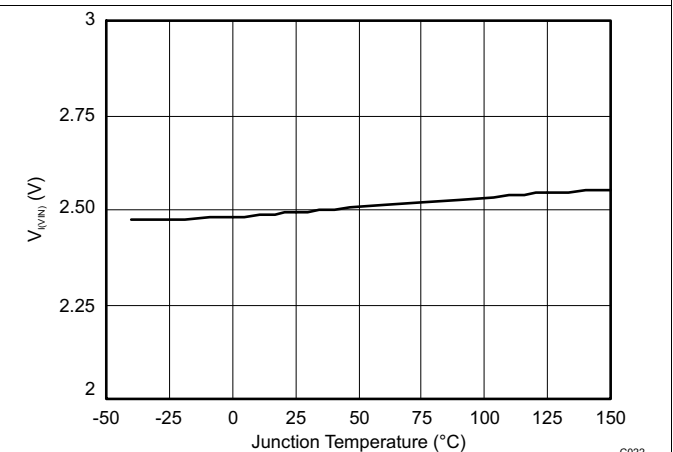

Figure 22. Input Voltage (UVLO) vs Junction Temperature

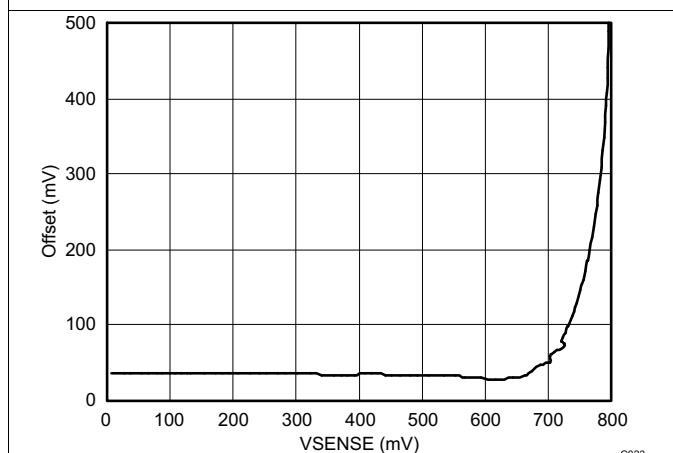

Figure 23. SS/TR TO VSENSE Offset vs VSENSE

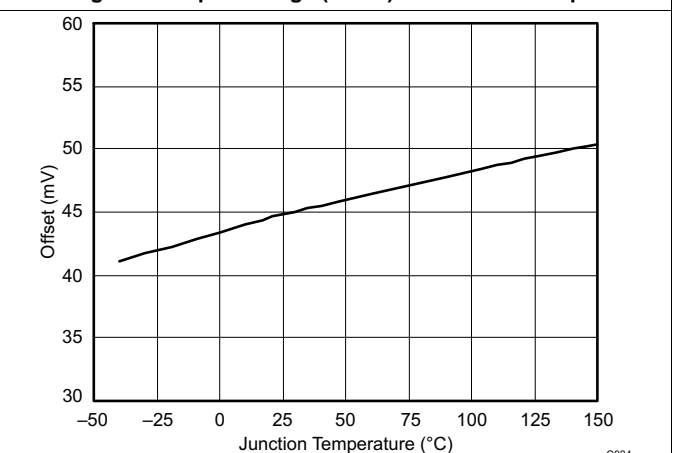

Figure 24. SS/TR TO VSENSE Offset vs Temperature

7 Detailed Description

7.1 Overview

The TPS54060 device is a 60-V, 0.5-A, step-down (buck) regulator with an integrated high side n-channel MOSFET. To improve performance during line and load transients the device implements a constant frequency, current mode control which reduces output capacitance and simplifies external frequency compensation design. The wide switching frequency of 100kHz to 2500kHz allows for efficiency and size optimization when selecting the output filter components. The switching frequency is adjusted using a resistor to ground on the RT/CLK pin. The device has an internal phase lock loop (PLL) on the RT/CLK pin that is used to synchronize the power switch turn on to a falling edge of an external system clock.

The TPS54060 has a default VIN start up voltage of approximately 2.5V. The EN pin has an internal pull-up current source that can be used to adjust the input voltage under voltage lockout (UVLO) threshold with two external resistors. In addition, the pull up current provides a default condition. When the EN pin is floating the device will operate. The operating current is 116 μ A when not switching and under no load. When the device is disabled, the supply current is 1.3 μ A.

The integrated 200m Ω high side MOSFET allows for high efficiency power supply designs capable of delivering 0.5 amperes of continuous current to a load. The TPS54060 reduces the external component count by integrating the boot recharge diode. The bias voltage for the integrated high side MOSFET is supplied by a capacitor on the BOOT to PH pin. The boot capacitor voltage is monitored by an UVLO circuit and will turn the high side MOSFET off when the boot voltage falls below a preset threshold. The TPS54060 can operate at high duty cycles because of the boot UVLO. The output voltage can be stepped down to as low as the 0.8V reference.

The TPS54060 has a power good comparator (PWRGD) which asserts when the regulated output voltage is less than 92% or greater than 109% of the nominal output voltage. The PWRGD pin is an open drain output which deasserts when the VSENSE pin voltage is between 94% and 107% of the nominal output voltage allowing the pin to transition high when a pull-up resistor is used.

The TPS54060 minimizes excessive output overvoltage (OV) transients by taking advantage of the OV power good comparator. When the OV comparator is activated, the high side MOSFET is turned off and masked from turning on until the output voltage is lower than 107%.

The SS/TR (slow start/tracking) pin is used to minimize inrush currents or provide power supply sequencing during power up. A small value capacitor should be coupled to the pin to adjust the slow start time. A resistor divider can be coupled to the pin for critical power supply sequencing requirements. The SS/TR pin is discharged before the output powers up. This discharging ensures a repeatable restart after an over-temperature fault, UVLO fault or a disabled condition.

The TPS54060, also, discharges the slow start capacitor during overload conditions with an overload recovery circuit. The overload recovery circuit will slow start the output from the fault voltage to the nominal regulation voltage once a fault condition is removed. A frequency foldback circuit reduces the switching frequency during startup and overcurrent fault conditions to help control the inductor current.

7.2 Functional Block Diagram

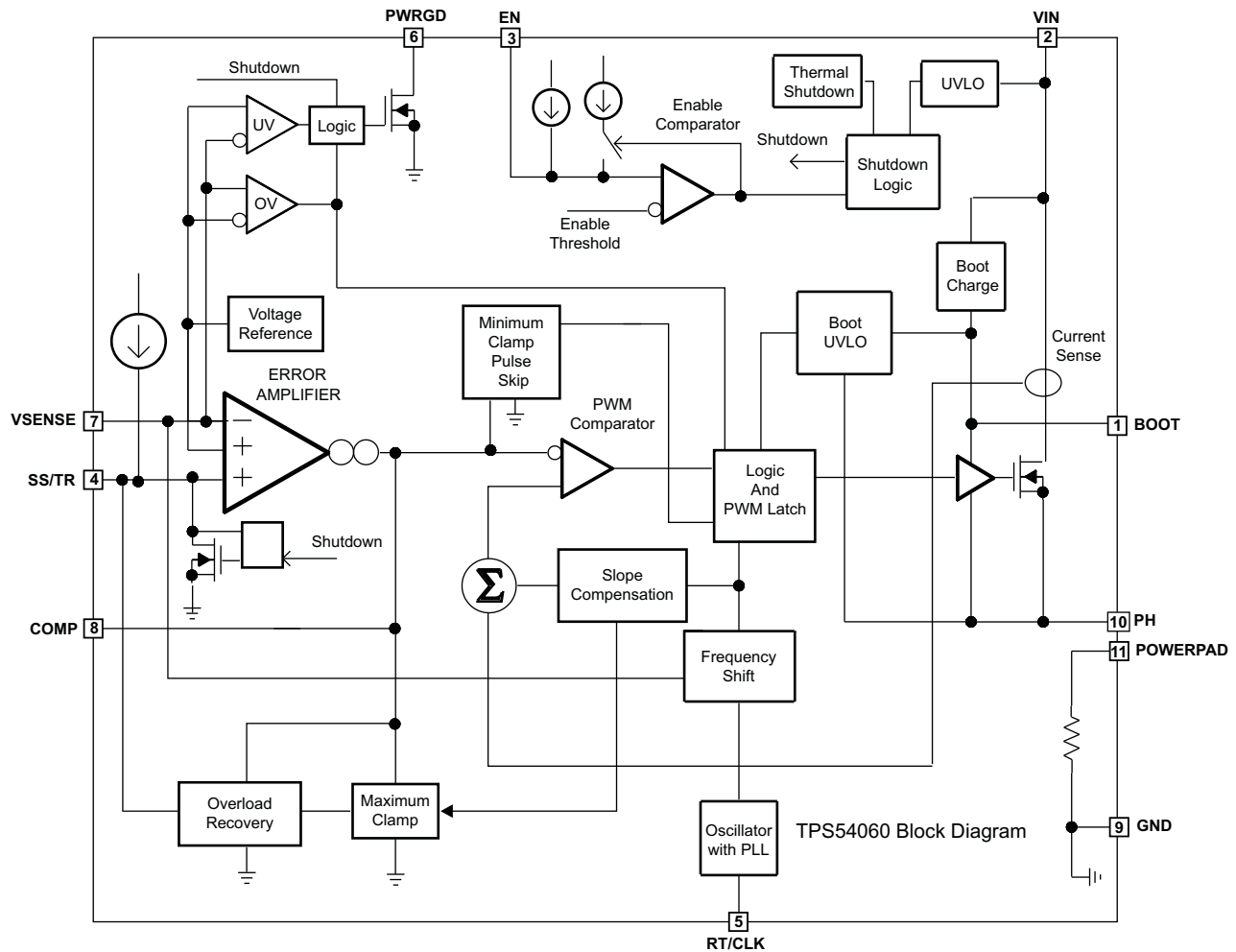

7.3 Feature Description

7.3.1 Fixed Frequency PWM Control

The TPS54060 uses an adjustable fixed frequency, peak current mode control. The output voltage is compared through external resistors on the VSENSE pin to an internal voltage reference by an error amplifier which drives the COMP pin. An internal oscillator initiates the turn on of the high side power switch. The error amplifier output is compared to the high side power switch current. When the power switch current reaches the level set by the COMP voltage, the power switch is turned off. The COMP pin voltage will increase and decrease as the output current increases and decreases. The device implements a current limit by clamping the COMP pin voltage to a maximum level. The Eco-Mode™ is implemented with a minimum clamp on the COMP pin.

7.3.2 Slope Compensation Output Current

The TPS54060 adds a compensating ramp to the switch current signal. This slope compensation prevents sub-harmonic oscillations. The available peak inductor current remains constant over the full duty cycle range.

7.3.3 Pulse Skip Eco-mode

The TPS54060 operates in a pulse skip Eco mode at light load currents to improve efficiency by reducing switching and gate drive losses. The TPS54060 is designed so that if the output voltage is within regulation and the peak switch current at the end of any switching cycle is below the pulse skipping current threshold, the device enters Eco mode. This current threshold is the current level corresponding to a nominal COMP voltage or 500mV.

Feature Description (continued)

When in Eco-mode, the COMP pin voltage is clamped at 500mV and the high side MOSFET is inhibited. Further decreases in load current or in output voltage can not drive the COMP pin below this clamp voltage level.

Since the device is not switching, the output voltage begins to decay. As the voltage control loop compensates for the falling output voltage, the COMP pin voltage begins to rise. At this time, the high side MOSFET is enabled and a switching pulse initiates on the next switching cycle. The peak current is set by the COMP pin voltage. The output voltage re-charges the regulated value (see [Figure 25](#)), then the peak switch current starts to decrease, and eventually falls below the Eco mode threshold at which time the device again enters Eco mode.

For Eco mode operation, the TPS54060 senses peak current, not average or load current, so the load current where the device enters Eco mode is dependent on the output inductor value. For example, the circuit in [Figure 50](#) enters Eco mode at about 20 mA of output current. When the load current is low and the output voltage is within regulation, the device enters a sleep mode and draws only 116µA input quiescent current. The average input current will be slightly higher than the non-switching input quiescent current because some switching is required to keep the output voltage regulated. The average input current will vary between applications. The internal PLL remains operating when in sleep mode. When operating at light load currents in the pulse skip mode, the switching transitions occur synchronously with the external clock signal.

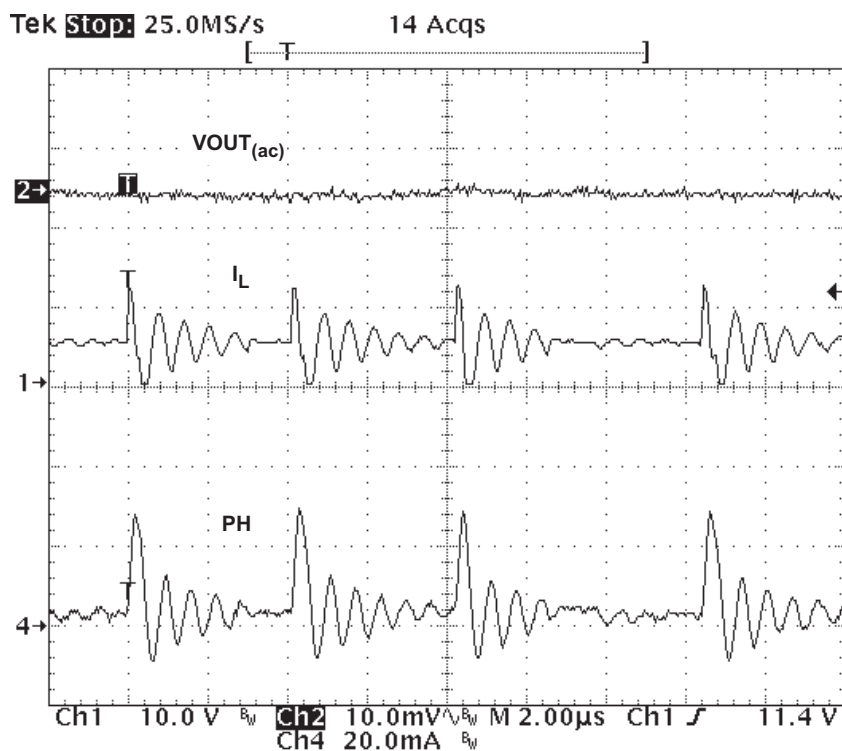

Figure 25. Pulse Skip Mode Operation

7.3.4 Low Dropout Operation and Bootstrap Voltage (BOOT)

The TPS54060 has an integrated boot regulator, and requires a small ceramic capacitor between the BOOT and PH pins to provide the gate drive voltage for the high side MOSFET. The BOOT capacitor is refreshed when the high side MOSFET is off and the low side diode conducts. The value of this ceramic capacitor should be 0.1µF. A ceramic capacitor with an X7R or X5R grade dielectric with a voltage rating of 10V or higher is recommended because of the stable characteristics over temperature and voltage.

To improve drop out, the TPS54060 is designed to operate at 100% duty cycle as long as the BOOT to PH pin voltage is greater than 2.1V. When the voltage from BOOT to PH drops below 2.1V, the high side MOSFET is turned off using an UVLO circuit which allows the low side diode to conduct and refresh the charge on the BOOT capacitor. Since the supply current sourced from the BOOT capacitor is low, the high side MOSFET can remain on for more switching cycles than are required to refresh the capacitor, thus the effective duty cycle of the switching regulator is high.

Feature Description (continued)

The effective duty cycle during dropout of the regulator is mainly influenced by the voltage drops across the power MOSFET, inductor resistance, low side diode and printed circuit board resistance. During operating conditions in which the input voltage drops and the regulator is operating in continuous conduction mode, the high side MOSFET can remain on for 100% of the duty cycle to maintain output regulation, until the BOOT to PH voltage falls below 2.1V.

Attention must be taken in maximum duty cycle applications which experience extended time periods with light loads or no load. When the voltage across the BOOT capacitor falls below the 2.1V UVLO threshold, the high side MOSFET is turned off, but there may not be enough inductor current to pull the PH pin down to recharge the BOOT capacitor. The high side MOSFET of the regulator stops switching because the voltage across the BOOT capacitor is less than 2.1V. The output capacitor then decays until the difference in the input voltage and output voltage is greater than 2.1V, at which point the BOOT UVLO threshold is exceeded, and the device starts switching again until the desired output voltage is reached. This operating condition persists until the input voltage and/or the load current increases. It is recommended to adjust the VIN stop voltage greater than the BOOT UVLO trigger condition at the minimum load of the application using the adjustable VIN UVLO feature with resistors on the EN pin.

The start and stop voltages for typical 3.3V and 5V output applications are shown in [Figure 26](#) and [Figure 27](#). The voltages are plotted versus load current. The start voltage is defined as the input voltage needed to regulate the output within 1%. The stop voltage is defined as the input voltage at which the output drops by 5% or stops switching.

During high duty cycle conditions, the inductor current ripple increases while the BOOT capacitor is being recharged resulting in an increase in ripple voltage on the output. This is due to the recharge time of the boot capacitor being longer than the typical high side off time when switching occurs every cycle.

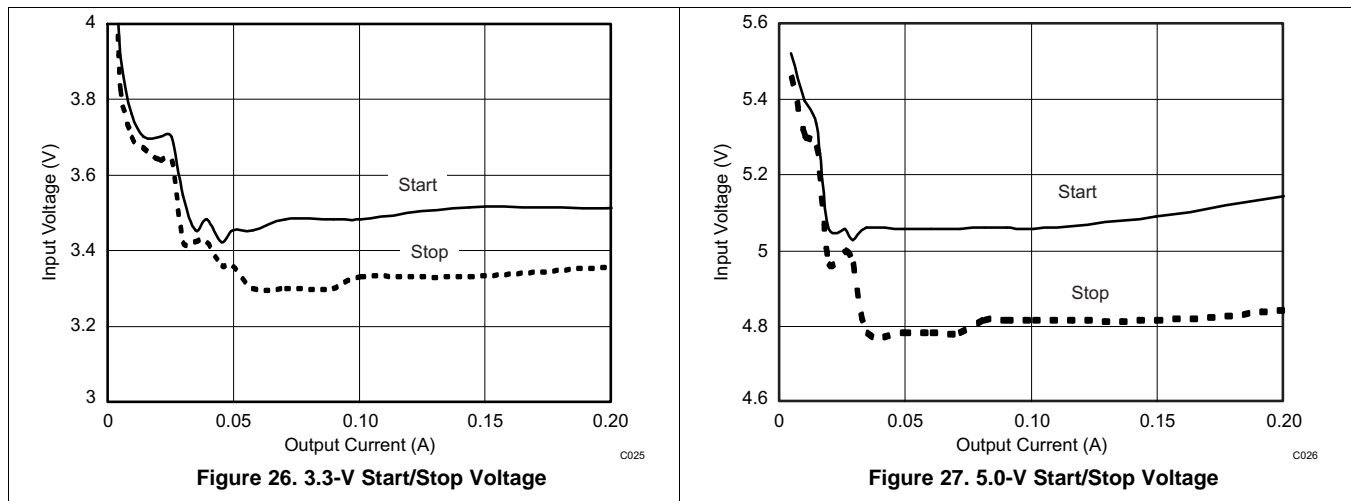

7.3.5 Error Amplifier

The TPS54060 has a transconductance amplifier for the error amplifier. The error amplifier compares the VSENSE voltage to the lower of the SS/TR pin voltage or the internal 0.8V voltage reference. The transconductance (gm) of the error amplifier is 97 μ A/V during normal operation. During the slow start operation, the transconductance is a fraction of the normal operating gm. When the voltage of the VSENSE pin is below 0.8V and the device is regulating using the SS/TR voltage, the gm is 25 μ A/V.

The frequency compensation components (capacitor, series resistor and capacitor) are added to the COMP pin to ground.

7.3.6 Voltage Reference

The voltage reference system produces a precise $\pm 2\%$ voltage reference over temperature by scaling the output of a temperature stable bandgap circuit.

Feature Description (continued)

7.3.7 Slow Start/Tracking Pin (SS/TR)

The TPS54060 effectively uses the lower voltage of the internal voltage reference or the SS/TR pin voltage as the power-supply's reference voltage and regulates the output accordingly. A capacitor on the SS/TR pin to ground implements a slow start time. The TPS54060 has an internal pull-up current source of 2µA that charges the external slow start capacitor. The calculations for the slow start time (10% to 90%) are shown in Equation 1. The voltage reference (V_{REF}) is 0.8 V and the slow start current (I_{SS}) is 2µA. The slow start capacitor should remain lower than 0.47µF and greater than 0.47nF.

$$C_{ss}(nF) = \frac{T_{ss}(ms) \times I_{ss}(\mu A)}{V_{ref}(V) \times 0.8} \tag{1}$$

At power up, the TPS54060 will not start switching until the slow start pin is discharged to less than 40 mV to ensure a proper power up, see Figure 28.

Also, during normal operation, the TPS54060 will stop switching and the SS/TR must be discharged to 40 mV, when the VIN voltage is below the VIN UVLO, EN pin pulled below 1.25V, or a thermal shutdown event occurs.

The V_{SENSE} voltage will follow the SS/TR pin voltage with a 45mV offset up to 85% of the internal voltage reference. When the SS/TR voltage is greater than 85% on the internal reference voltage the offset increases as the effective system reference transitions from the SS/TR voltage to the internal voltage reference (see Figure 23). The SS/TR voltage will ramp linearly until clamped at 1.7V.

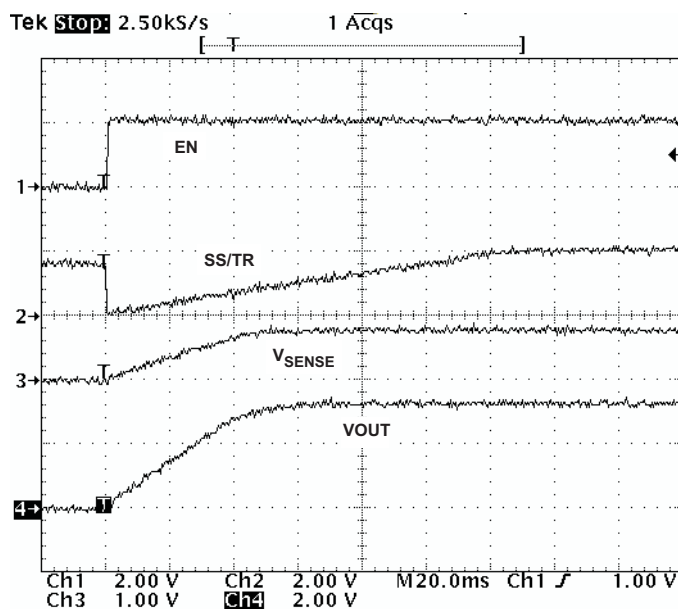

Figure 28. Operation of SS/TR Pin when Starting

7.3.8 Overload Recovery Circuit

The TPS54060 has an overload recovery (OLR) circuit. The OLR circuit will slow start the output from the overload voltage to the nominal regulation voltage once the fault condition is removed. The OLR circuit will discharge the SS/TR pin to a voltage slightly greater than the V_{SENSE} pin voltage using an internal pull down of 100µA when the error amplifier is changed to a high voltage from a fault condition. When the fault condition is removed, the output will slow start from the fault voltage to nominal output voltage.

Feature Description (continued)

7.3.9 Constant Switching Frequency and Timing Resistor (RT/CLK Pin)

The switching frequency of the TPS54060 is adjustable over a wide range from approximately 100kHz to 2500kHz by placing a resistor on the RT/CLK pin. The RT/CLK pin voltage is typically 0.5V and must have a resistor to ground to set the switching frequency. To determine the timing resistance for a given switching frequency, use Equation 2 or the curves in Figure 29 or Figure 30. To reduce the solution size one would typically set the switching frequency as high as possible, but tradeoffs of the supply efficiency, maximum input voltage and minimum controllable on time should be considered.

The minimum controllable on time is typically 130ns and limits the maximum operating input voltage.

The maximum switching frequency is also limited by the frequency shift circuit. More discussion on the details of the maximum switching frequency is located below.

$$RT \text{ (k}\Omega\text{)} = \frac{206033}{f_{sw} \text{ (kHz)}^{1.0888}} \tag{2}$$

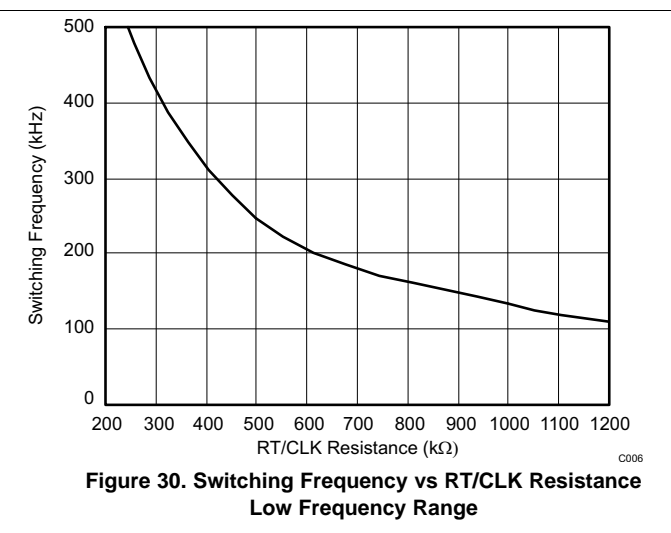
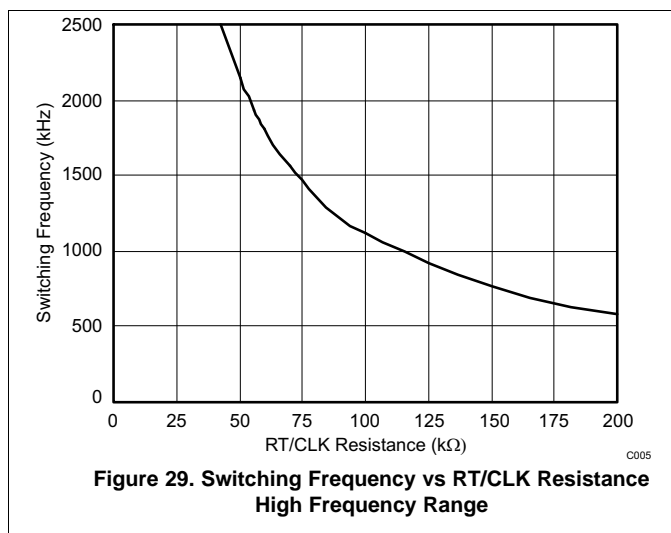

7.3.10 Overcurrent Protection and Frequency Shift

The TPS54060 implements current mode control which uses the COMP pin voltage to turn off the high side MOSFET on a cycle by cycle basis. Each cycle the switch current and COMP pin voltage are compared, when the peak switch current intersects the COMP voltage, the high side switch is turned off. During overcurrent conditions that pull the output voltage low, the error amplifier will respond by driving the COMP pin high, increasing the switch current. The error amplifier output is clamped internally, which functions as a switch current limit.

To increase the maximum operating switching frequency at high input voltages the TPS54060 implements a frequency shift. The switching frequency is divided by 8, 4, 2, and 1 as the voltage ramps from 0 to 0.8 volts on VSENSE pin.

The device implements a digital frequency shift to enable synchronizing to an external clock during normal startup and fault conditions. Since the device can only divide the switching frequency by 8, there is a maximum input voltage limit in which the device operates and still have frequency shift protection.

During short-circuit events (particularly with high input voltage applications), the control loop has a finite minimum controllable on time and the output has a low voltage. During the switch on time, the inductor current ramps to the peak current limit because of the high input voltage and minimum on time. During the switch off time, the inductor would normally not have enough off time and output voltage for the inductor to ramp down by the ramp up amount. The frequency shift effectively increases the off time allowing the current to ramp down.

Feature Description (continued)

7.3.11 Power Good (PWRGD Pin)

The PWRGD pin is an open drain output. Once the VSENSE pin is between 94% and 107% of the internal voltage reference the PWRGD pin is de-asserted and the pin floats. It is recommended to use a pull-up resistor between the values of 10 and 100kΩ to a voltage source that is 5.5V or less. The PWRGD is in a defined state once the VIN input voltage is greater than 1.5V but with reduced current sinking capability. The PWRGD will achieve full current sinking capability as VIN input voltage approaches 3V.

The PWRGD pin is pulled low when the VSENSE is lower than 92% or greater than 109% of the nominal internal reference voltage. Also, the PWRGD is pulled low, if the UVLO or thermal shutdown are asserted or the EN pin pulled low.

7.3.12 Overvoltage Transient Protection

The TPS54060 incorporates an overvoltage transient protection (OVTP) circuit to minimize voltage overshoot when recovering from output fault conditions or strong unload transients on power supply designs with low value output capacitance. For example, when the power supply output is overloaded the error amplifier compares the actual output voltage to the internal reference voltage. If the VSENSE pin voltage is lower than the internal reference voltage for a considerable time, the output of the error amplifier will respond by clamping the error amplifier output to a high voltage. Thus, requesting the maximum output current. Once the condition is removed, the regulator output rises and the error amplifier output transitions to the steady state duty cycle. In some applications, the power supply output voltage can respond faster than the error amplifier output can respond, this actuality leads to the possibility of an output overshoot. The OVTP feature minimizes the output overshoot, when using a low value output capacitor, by implementing a circuit to compare the VSENSE pin voltage to OVTP threshold which is 109% of the internal voltage reference. If the VSENSE pin voltage is greater than the OVTP threshold, the high side MOSFET is disabled preventing current from flowing to the output and minimizing output overshoot. When the VSENSE voltage drops lower than the OVTP threshold, the high side MOSFET is allowed to turn on at the next clock cycle.

7.3.13 Thermal Shutdown

The device implements an internal thermal shutdown to protect itself if the junction temperature exceeds 182°C. The thermal shutdown forces the device to stop switching when the junction temperature exceeds the thermal trip threshold. Once the die temperature decreases below 182°C, the device reinitiates the power up sequence by discharging the SS/TR pin.

7.3.14 Small Signal Model for Loop Response

Figure 31 shows an equivalent model for the TPS54060 control loop which can be modeled in a circuit simulation program to check frequency response and dynamic load response. The error amplifier is a transconductance amplifier with a $g_{m_{EA}}$ of 97 $\mu A/V$. The error amplifier can be modeled using an ideal voltage controlled current source. The resistor R_o and capacitor C_o model the open loop gain and frequency response of the amplifier. The 1mV ac voltage source between the nodes a and b effectively breaks the control loop for the frequency response measurements. Plotting c/a shows the small signal response of the frequency compensation. Plotting a/b shows the small signal response of the overall loop. The dynamic loop response can be checked by replacing R_L with a current source with the appropriate load step amplitude and step rate in a time domain analysis. This equivalent model is only valid for continuous conduction mode designs.

Feature Description (continued)

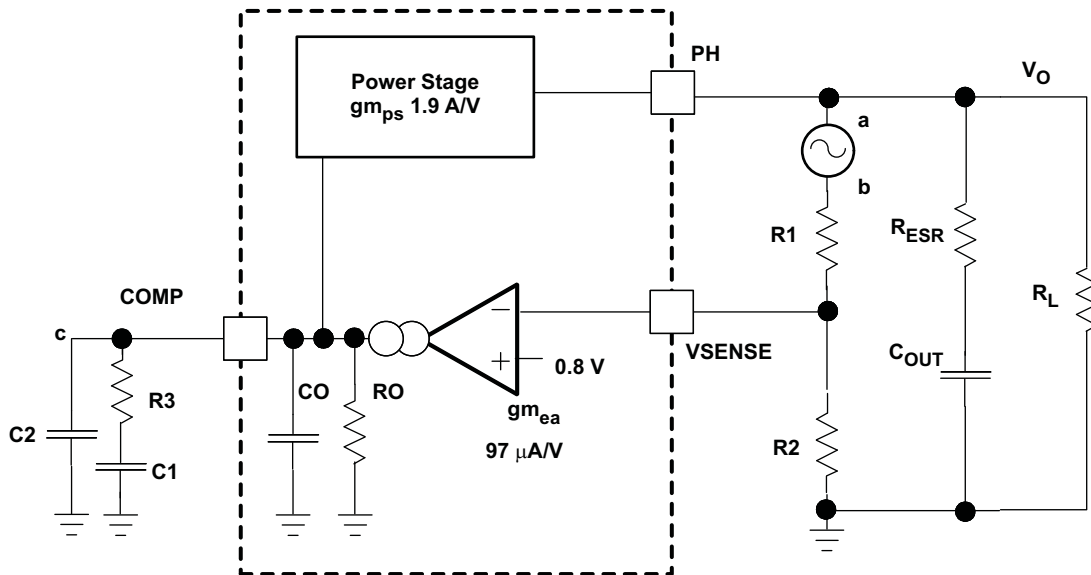

Figure 31. Small Signal Model for Loop Response

7.3.15 Simple Small Signal Model for Peak Current Mode Control

Figure 32 describes a simple small signal model that can be used to understand how to design the frequency compensation. The TPS54060 power stage can be approximated to a voltage-controlled current source (duty cycle modulator) supplying current to the output capacitor and load resistor. The control to output transfer function is shown in Equation 3 and consists of a dc gain, one dominant pole, and one ESR zero. The quotient of the change in switch current and the change in COMP pin voltage (node c in Figure 31) is the power stage transconductance. The $g_{m_{ps}}$ for the TPS54060 is 1.9A/V. The low-frequency gain of the power stage frequency response is the product of the transconductance and the load resistance as shown in Equation 4.

As the load current increases and decreases, the low-frequency gain decreases and increases, respectively. This variation with the load may seem problematic at first glance, but fortunately the dominant pole moves with the load current (see Equation 5). The combined effect is highlighted by the dashed line in the right half of Figure 32. As the load current decreases, the gain increases and the pole frequency lowers, keeping the 0-dB crossover frequency the same for the varying load conditions which makes it easier to design the frequency compensation. The type of output capacitor chosen determines whether the ESR zero has a profound effect on the frequency compensation design. Using high ESR aluminum electrolytic capacitors may reduce the number frequency compensation components needed to stabilize the overall loop because the phase margin increases from the ESR zero at the lower frequencies (see Equation 6).

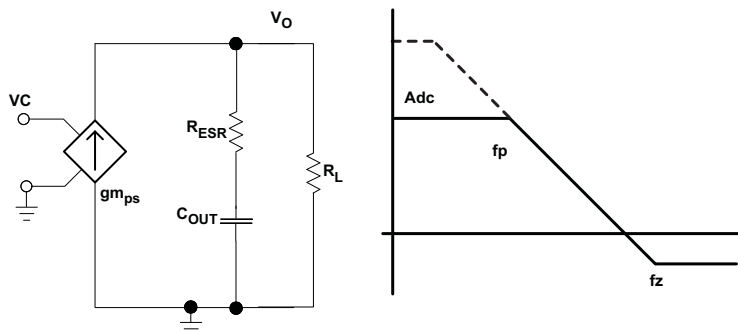

Figure 32. Simple Small Signal Model and Frequency Response for Peak Current Mode Control

Feature Description (continued)

$$\frac{V_{OUT}}{V_C} = A_{dc} \times \frac{\left(1 + \frac{s}{2\pi \times f_Z}\right)}{\left(1 + \frac{s}{2\pi \times f_P}\right)} \tag{3}$$

$$A_{dc} = g_{m_{ps}} \times R_L \tag{4}$$

$$f_P = \frac{1}{C_{OUT} \times R_L \times 2\pi} \tag{5}$$

$$f_Z = \frac{1}{C_{OUT} \times R_{ESR} \times 2\pi} \tag{6}$$

7.3.16 Small Signal Model for Frequency Compensation

The TPS54060 uses a transconductance amplifier for the error amplifier and readily supports three of the commonly-used frequency compensation circuits. Compensation circuits Type 2A, Type 2B, and Type 1 are shown in Figure 33. Type 2 circuits most likely implemented in high bandwidth power-supply designs using low ESR output capacitors. The Type 1 circuit is used with power-supply designs with high-ESR aluminum electrolytic or tantalum capacitors. Equation 7 and Equation 8 show how to relate the frequency response of the amplifier to the small signal model in Figure 33. The open-loop gain and bandwidth are modeled using the R_O and C_O shown in Figure 33. See the application section for a design example using a Type 2A network with a low ESR output capacitor.

Equation 7 through Equation 16 are provided as a reference for those who prefer to compensate using the preferred methods. Those who prefer to use prescribed method use the method outlined in the application section or use switched information.

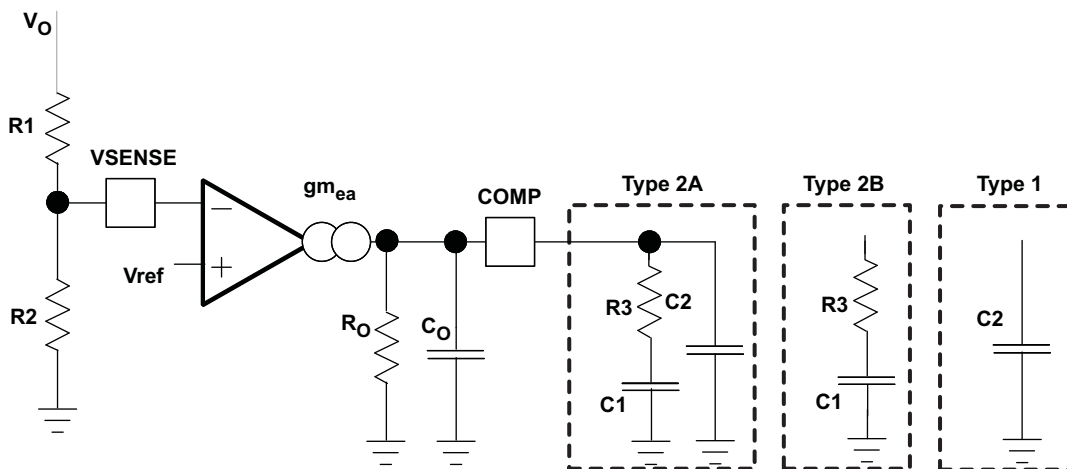
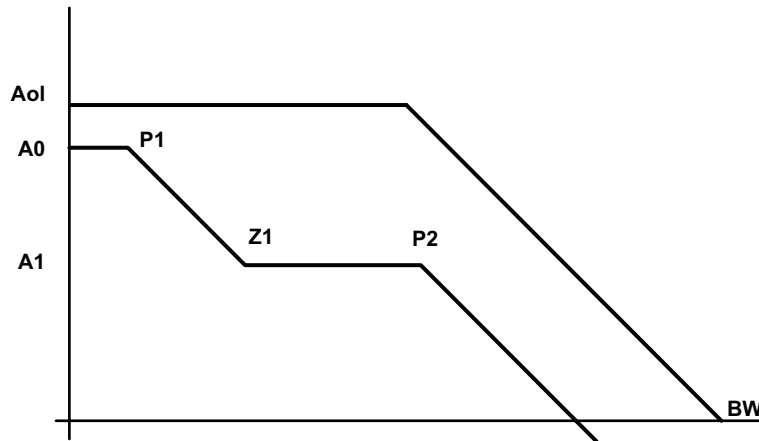

Figure 33. Types of Frequency Compensation

Feature Description (continued)

Figure 34. Frequency Response of the Type 2A and Type 2B Frequency Compensation

$$R_o = \frac{A_{ol}(V/V)}{g_{m_{ea}}} \quad (7)$$

$$C_o = \frac{g_{m_{ea}}}{2\pi \times BW \text{ (Hz)}} \quad (8)$$

$$EA = A_0 \times \frac{\left(1 + \frac{s}{2\pi \times f_{Z1}}\right)}{\left(1 + \frac{s}{2\pi \times f_{P1}}\right) \times \left(1 + \frac{s}{2\pi \times f_{P2}}\right)} \quad (9)$$

$$A_0 = g_{m_{ea}} \times R_o \times \frac{R_2}{R_1 + R_2} \quad (10)$$

$$A_1 = g_{m_{ea}} \times R_o || R_3 \times \frac{R_2}{R_1 + R_2} \quad (11)$$

$$P_1 = \frac{1}{2\pi \times R_o \times C_1} \quad (12)$$

$$Z_1 = \frac{1}{2\pi \times R_3 \times C_1} \quad (13)$$

$$P_2 = \frac{1}{2\pi \times R_3 || R_o \times (C_2 + C_o)} \text{ type 2a} \quad (14)$$

$$P_2 = \frac{1}{2\pi \times R_3 || R_o \times C_o} \text{ type 2b} \quad (15)$$

$$P_2 = \frac{1}{2\pi \times R_o \times (C_2 + C_o)} \text{ type 1} \quad (16)$$

7.4 Device Functional Modes

The TPS54060 is designed to operate with input voltages above 3.5 V. When the VIN voltage is above the 2.5 V typical UVLO threshold and the EN voltage is above the 1.25 V typical threshold the device is active. If the VIN voltage falls below the typical 2.5-V UVLO threshold the device stops switching. If the EN voltage falls below the 1.25-V threshold the device stops switching and enters a shutdown mode with low supply current of 1.3 μ A typical.

Device Functional Modes (continued)

The TPS54060 will operate in CCM when the output current is enough to keep the inductor current above 0 A at the end of each switching period. As a non-synchronous converter it will enter DCM at low output currents when the inductor current falls to 0 A before the end of a switching period. At very low output current the COMP voltage will drop to the pulse skipping threshold and the device operates in a pulse-skipping Eco-mode. In this mode the high-side MOSFET does not switch every switching period. This operating mode reduces power loss while keeping the output voltage regulated. For more information on Eco-mode see the [Pulse Skip Eco-mode](#) section.

8 Application and Implementation

NOTE

Information in the following applications sections is not part of the TI component specification, and TI does not warrant its accuracy or completeness. TI's customers are responsible for determining suitability of components for their purposes. Customers should validate and test their design implementation to confirm system functionality.

8.1 Application Information

The TPS54060 device is a 60-V, 0.5-A, step-down regulator with an integrated high-side MOSFET. This device typically converts a higher dc voltage to a lower dc voltage with a maximum available output current of 0.5 A. Example applications are: 12-V, 24-V, and 48-V industrial, automotive and communication power systems. Use the following design procedure to select component values for the TPS54060 device. The Excel[®] spreadsheet (SLVC432) located on the product page can help on all calculations. Alternatively, use the WEBENCH software to generate a complete design. The WEBENCH software uses an iterative design procedure and accesses a comprehensive database of components when generating a design.

8.1.1 Adjusting the Output Voltage

The output voltage is set with a resistor divider from the output node to the VSENSE pin. It is recommended to use 1% tolerance or better divider resistors. Start with a 10 kΩ for the R2 resistor and use the Equation 17 to calculate R1. To improve efficiency at light loads consider using larger value resistors. If the values are too high the regulator will be more susceptible to noise and voltage errors from the VSENSE input current will be noticeable

$$R1 = R2 \times \left(\frac{V_{out} - 0.8V}{0.8V} \right) \quad (17)$$

8.1.2 Enable and Adjusting Undervoltage Lockout

The TPS54060 is disabled when the VIN pin voltage falls below 2.5 V. If an application requires a higher undervoltage lockout (UVLO), use the EN pin as shown in Figure 35 to adjust the input voltage UVLO by using the two external resistors. Though it is not necessary to use the UVLO adjust registers, for operation it is highly recommended to provide consistent power up behavior. The EN pin has an internal pull-up current source, I1, of 0.9μA that provides the default condition of the TPS54060 operating when the EN pin floats. Once the EN pin voltage exceeds 1.25V, an additional 2.9μA of hysteresis, I_{hys}, is added. This additional current facilitates input voltage hysteresis. Use Equation 18 to set the external hysteresis for the input voltage. Use Equation 19 to set the input start voltage.

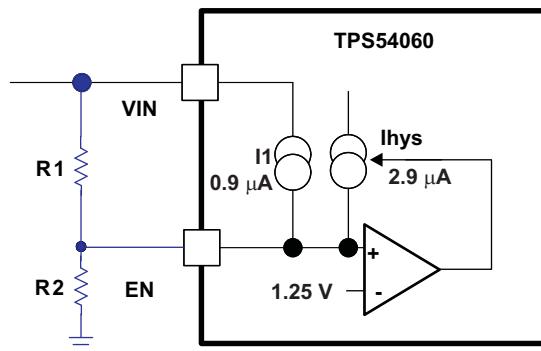

Figure 35. Adjustable Undervoltage Lockout (UVLO)

$$R1 = \frac{V_{START} - V_{STOP}}{I_{HYS}} \quad (18)$$

Application Information (continued)

$$R2 = \frac{V_{ENA}}{\frac{V_{START} - V_{ENA}}{R1} + I_1} \tag{19}$$

Another technique to add input voltage hysteresis is shown in [Figure 36](#). This method may be used, if the resistance values are high from the previous method and a wider voltage hysteresis is needed. The resistor R3 sources additional hysteresis current into the EN pin.

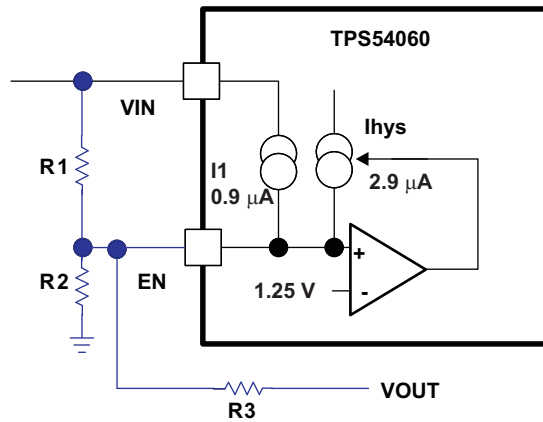

Figure 36. Adding Additional Hysteresis

$$R1 = \frac{V_{START} - V_{STOP}}{I_{HYS} + \frac{V_{OUT}}{R3}} \tag{20}$$

$$R2 = \frac{V_{ENA}}{\frac{V_{START} - V_{ENA}}{R1} + I_1 - \frac{V_{ENA}}{R3}} \tag{21}$$

8.1.3 Sequencing

Many of the common power supply sequencing methods can be implemented using the SS/TR, EN and PWRGD pins. The sequential method can be implemented using an open drain output of a power on reset pin of another device. The sequential method is illustrated in [Figure 37](#) using two TPS54060 devices. The power good is coupled to the EN pin on the TPS54060 which will enable the second power supply once the primary supply reaches regulation. If needed, a 1nF ceramic capacitor on the EN pin of the second power supply will provide a 1ms start up delay. [Figure 38](#) shows the results of [Figure 37](#).

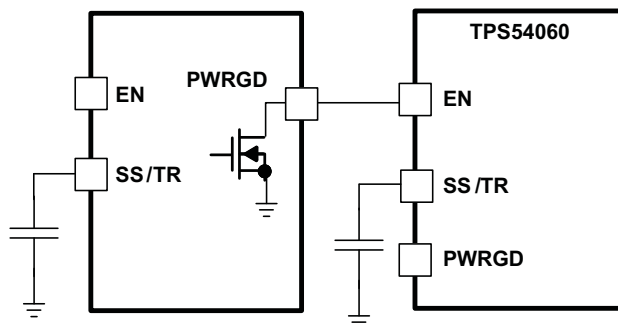

Figure 37. Schematic for Sequential Start-Up Sequence

Application Information (continued)

Figure 38. Sequential Startup Using EN and PWRGD

Figure 39. Schematic for Ratiometric Start-Up Sequence

Figure 40. Ratiometric Start-Up Using Coupled SS/TR Pins

Figure 39 shows a method for ratio-metric start up sequence by connecting the SS/TR pins together. The regulator outputs will ramp up and reach regulation at the same time. When calculating the slow start time the pull up current source must be doubled in Equation 1. Figure 40 shows the results of Figure 39.

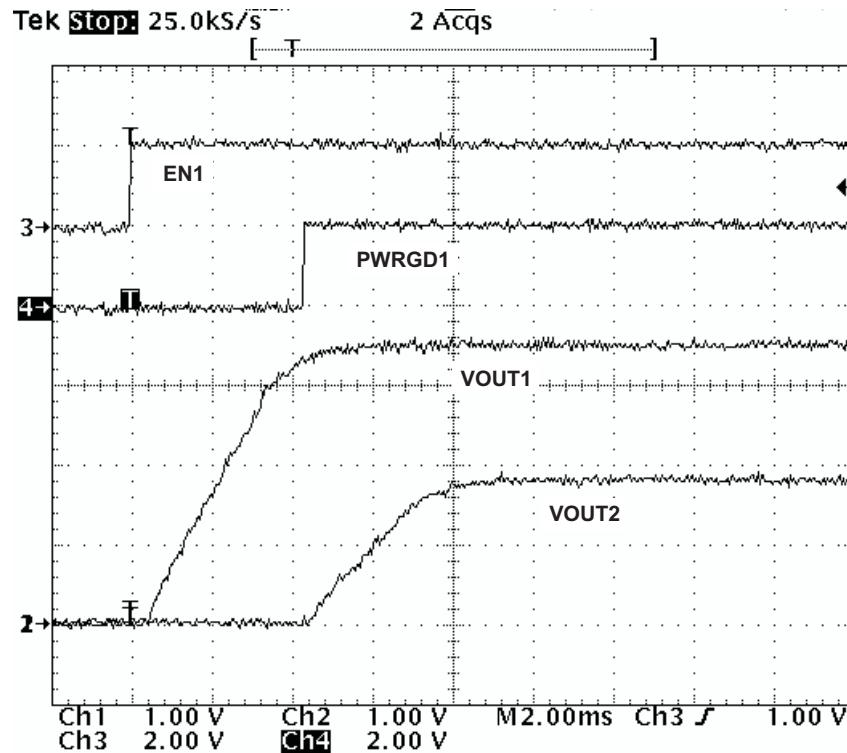
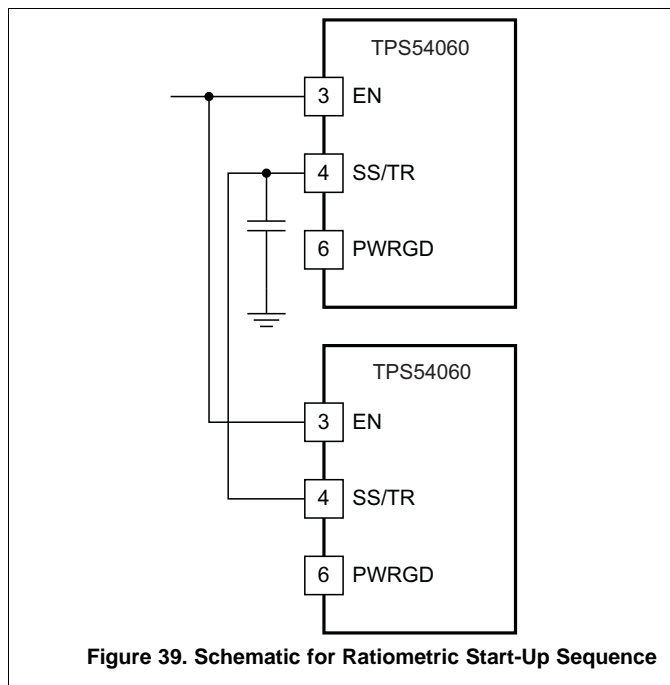
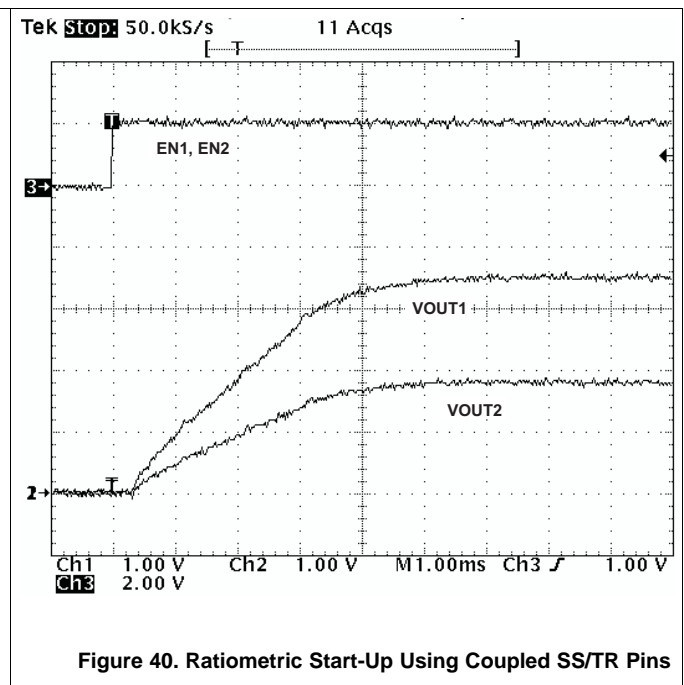
Application Information (continued)

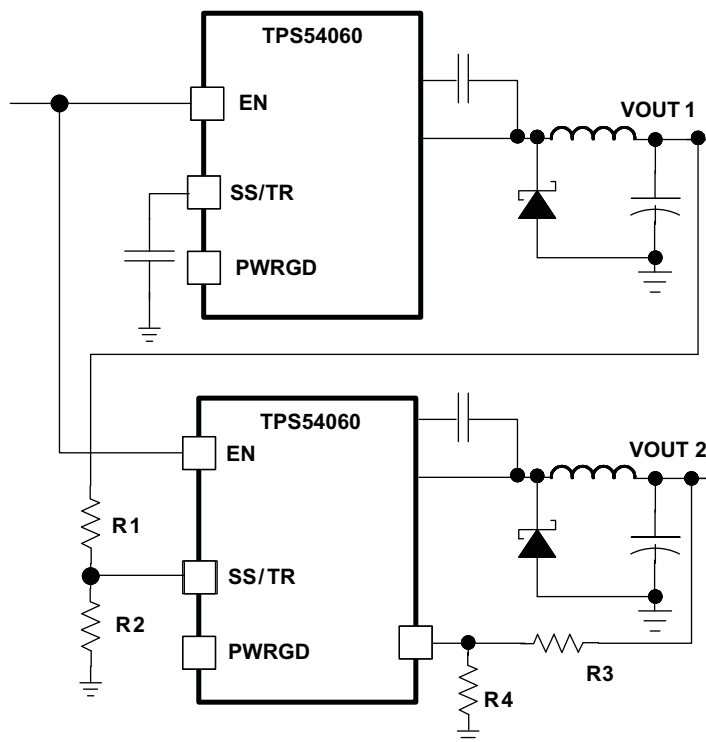

Figure 41. Schematic for Ratiometric and Simultaneous Start-Up Sequence

Ratio-metric and simultaneous power supply sequencing can be implemented by connecting the resistor network of R1 and R2 shown in Figure 41 to the output of the power supply that needs to be tracked or another voltage reference source. Using Equation 22 and Equation 23, the tracking resistors can be calculated to initiate the Vout2 slightly before, after or at the same time as Vout1. Equation 24 is the voltage difference between Vout1 and Vout2 at the 95% of nominal output regulation.

The deltaV variable is zero volts for simultaneous sequencing. To minimize the effect of the inherent SS/TR to VSENSE offset (Vssoffset) in the slow start circuit and the offset created by the pullup current source (Iss) and tracking resistors, the Vssoffset and Iss are included as variables in the equations.

To design a ratio-metric start up in which the Vout2 voltage is slightly greater than the Vout1 voltage when Vout2 reaches regulation, use a negative number in Equation 22 through Equation 24 for deltaV. Equation 24 will result in a positive number for applications which the Vout2 is slightly lower than Vout1 when Vout2 regulation is achieved.

Since the SS/TR pin must be pulled below 40mV before starting after an EN, UVLO or thermal shutdown fault, careful selection of the tracking resistors is needed to ensure the device will restart after a fault. Make sure the calculated R1 value from Equation 22 is greater than the value calculated in Equation 25 to ensure the device can recover from a fault.

As the SS/TR voltage becomes more than 85% of the nominal reference voltage the Vssoffset becomes larger as the slow start circuits gradually handoff the regulation reference to the internal voltage reference. The SS/TR pin voltage needs to be greater than 1.3V for a complete handoff to the internal voltage reference as shown in Figure 23.

Application Information (continued)

$$R1 = \frac{V_{out2} + \Delta V}{V_{REF}} \times \frac{V_{ssoffset}}{I_{ss}} \tag{22}$$

$$R2 = \frac{V_{REF} \times R1}{V_{out2} + \Delta V - V_{REF}} \tag{23}$$

$$\Delta V = V_{out1} - V_{out2} \tag{24}$$

$$R1 > 2800 \times V_{out1} - 180 \times \Delta V \tag{25}$$

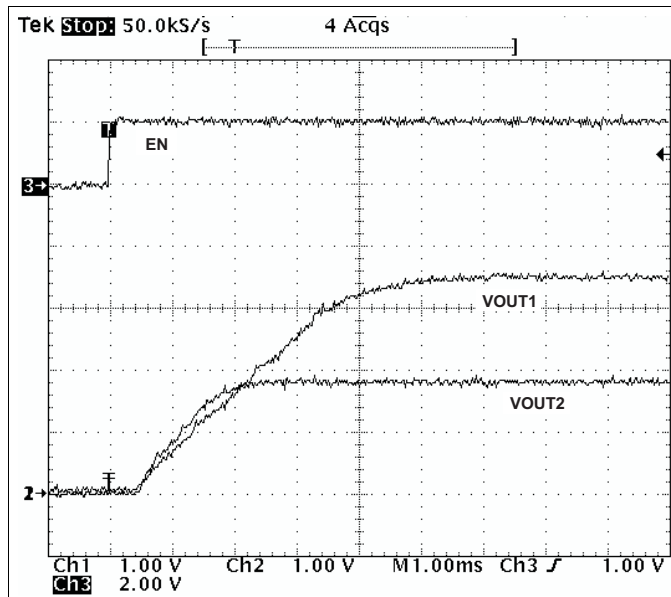

Figure 42. Ratiometric Startup With Tracking Resistors

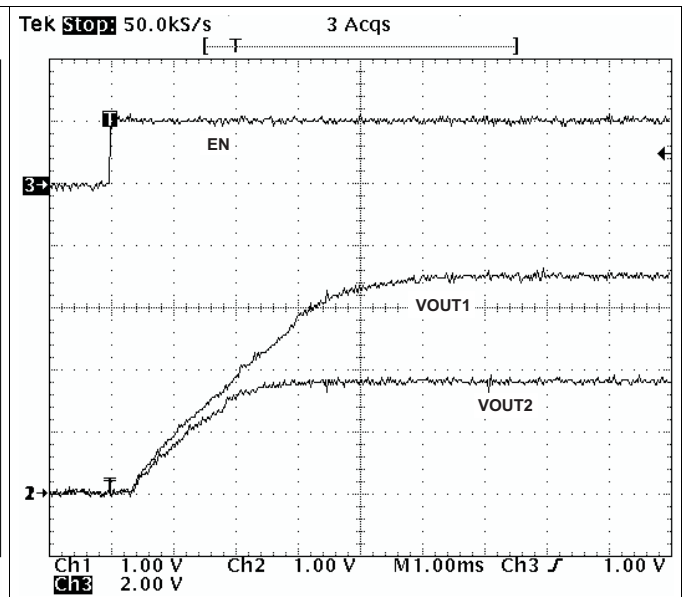

Figure 43. Ratiometric Startup With Tracking Resistors

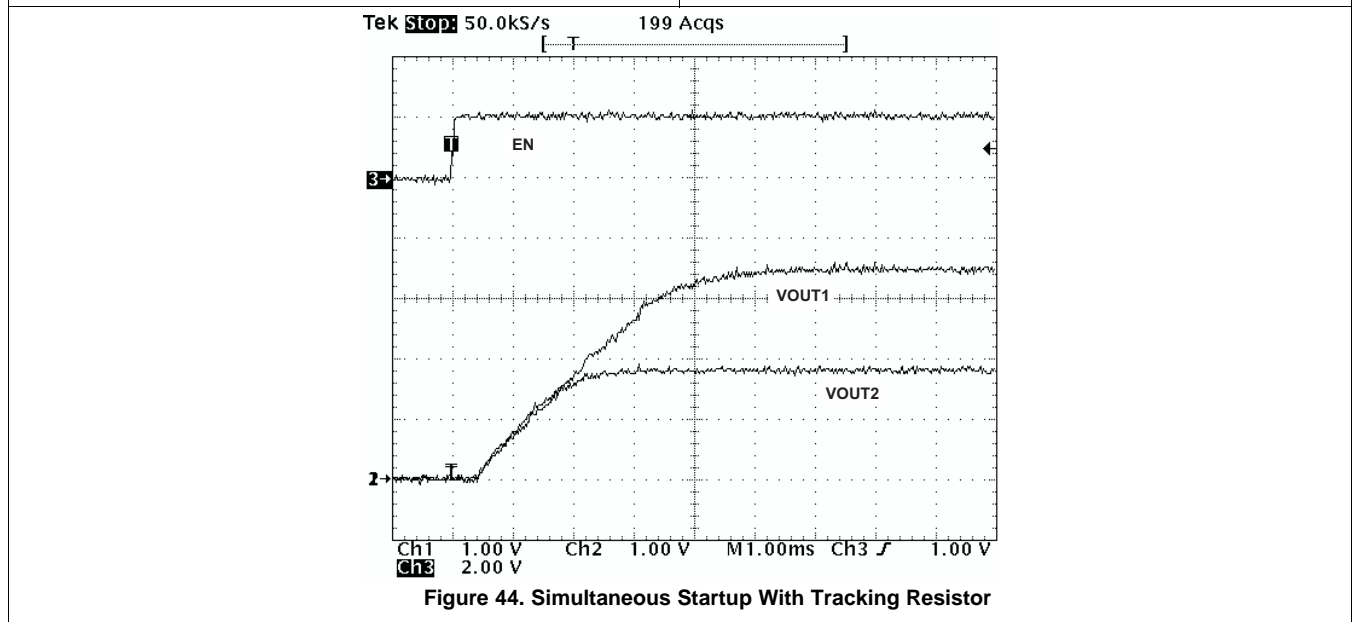

Figure 44. Simultaneous Startup With Tracking Resistor

Application Information (continued)

8.1.4 Selecting the Switching Frequency

The switching frequency that is selected should be the lower value of the two equations, [Equation 26](#) and [Equation 27](#). [Equation 26](#) is the maximum switching frequency limitation set by the minimum controllable on time. Setting the switching frequency above this value will cause the regulator to skip switching pulses.

[Equation 27](#) is the maximum switching frequency limit set by the frequency shift protection. To have adequate output short circuit protection at high input voltages, the switching frequency should be set to be less than the fsw(maxshift) frequency. In [Equation 27](#), to calculate the maximum switching frequency one must take into account that the output voltage decreases from the nominal voltage to 0 volts, the fdiv integer increases from 1 to 8 corresponding to the frequency shift.

In [Figure 45](#), the solid line illustrates a typical safe operating area regarding frequency shift and assumes the output voltage is zero volts, and the resistance of the inductor is 0.130Ω, FET on resistance of 0.2Ω and the diode voltage drop is 0.5V. The dashed line is the maximum switching frequency to avoid pulse skipping. Enter these equations in a spreadsheet or other software or use the SwitcherPro design software to determine the switching frequency.

$$f_{SW(maxskip)} = \left(\frac{1}{t_{ON}} \right) \times \left(\frac{(I_L \times R_{dc} + V_{OUT} + V_d)}{(V_{IN} - I_L \times R_{hs} + V_d)} \right) \tag{26}$$

$$f_{SW(shift)} = \frac{f_{div}}{t_{ON}} \times \left(\frac{(I_L \times R_{dc} + V_{OUTSC} + V_d)}{(V_{IN} - I_L \times R_{hs} + V_d)} \right) \tag{27}$$

- I_L inductor current
- R_{dc} inductor resistance
- V_{IN} maximum input voltage
- V_{OUT} output voltage
- V_{OUTSC} output voltage during short
- V_d diode voltage drop
- $R_{DS(on)}$ switch on resistance
- t_{ON} controllable on time
- f_{DIV} frequency divide equals (1, 2, 4, or 8)

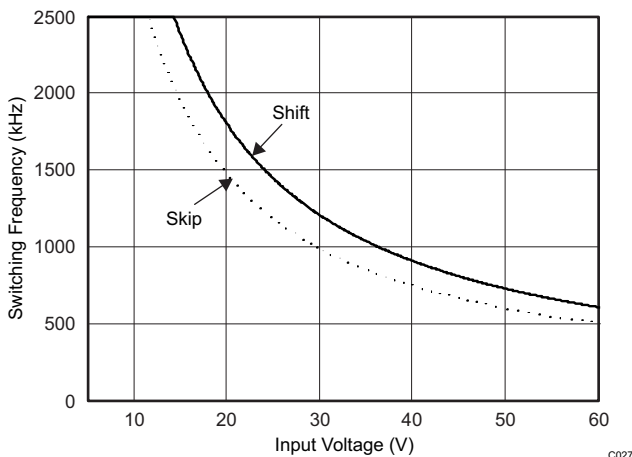

Figure 45. Maximum Switching Frequency vs Input Voltage

Application Information (continued)

8.1.5 How to Interface to RT/CLK Pin

The RT/CLK pin can be used to synchronize the regulator to an external system clock. To implement the synchronization feature connect a square wave to the RT/CLK pin through the circuit network shown in Figure 46. The square wave amplitude must transition lower than 0.5V and higher than 2.2V on the RT/CLK pin and have an on time greater than 40 ns and an off time greater than 40 ns. The synchronization frequency range is 300 kHz to 2200 kHz. The rising edge of the PH will be synchronized to the falling edge of RT/CLK pin signal. The external synchronization circuit should be designed in such a way that the device will have the default frequency set resistor connected from the RT/CLK pin to ground should the synchronization signal turn off. It is recommended to use a frequency set resistor connected as shown in Figure 46 through a 50Ω resistor to ground. The resistor should set the switching frequency close to the external CLK frequency. It is recommended to ac couple the synchronization signal through a 10 pF ceramic capacitor to RT/CLK pin and a 4kΩ series resistor. The series resistor reduces PH jitter in heavy load applications when synchronizing to an external clock and in applications which transition from synchronizing to RT mode. The first time the CLK is pulled above the CLK threshold the device switches from the RT resistor frequency to PLL mode. The internal 0.5V voltage source is removed and the CLK pin becomes high impedance as the PLL starts to lock onto the external signal. Since there is a PLL on the regulator the switching frequency can be higher or lower than the frequency set with the external resistor. The device transitions from the resistor mode to the PLL mode and then will increase or decrease the switching frequency until the PLL locks onto the CLK frequency within 100 microseconds.

When the device transitions from the PLL to resistor mode the switching frequency will slow down from the CLK frequency to 150 kHz, then reapply the 0.5V voltage and the resistor will then set the switching frequency. The switching frequency is divided by 8, 4, 2, and 1 as the voltage ramps from 0 to 0.8 volts on VSENSE pin. The device implements a digital frequency shift to enable synchronizing to an external clock during normal startup and fault conditions. Figure 47, Figure 48 and Figure 49 show the device synchronized to an external system clock in continuous conduction mode (ccm) discontinuous conduction (dcm) and pulse skip mode (psm).

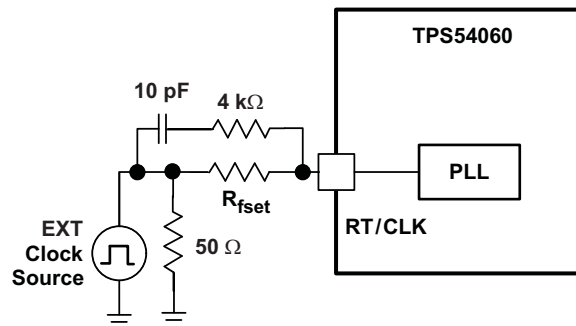
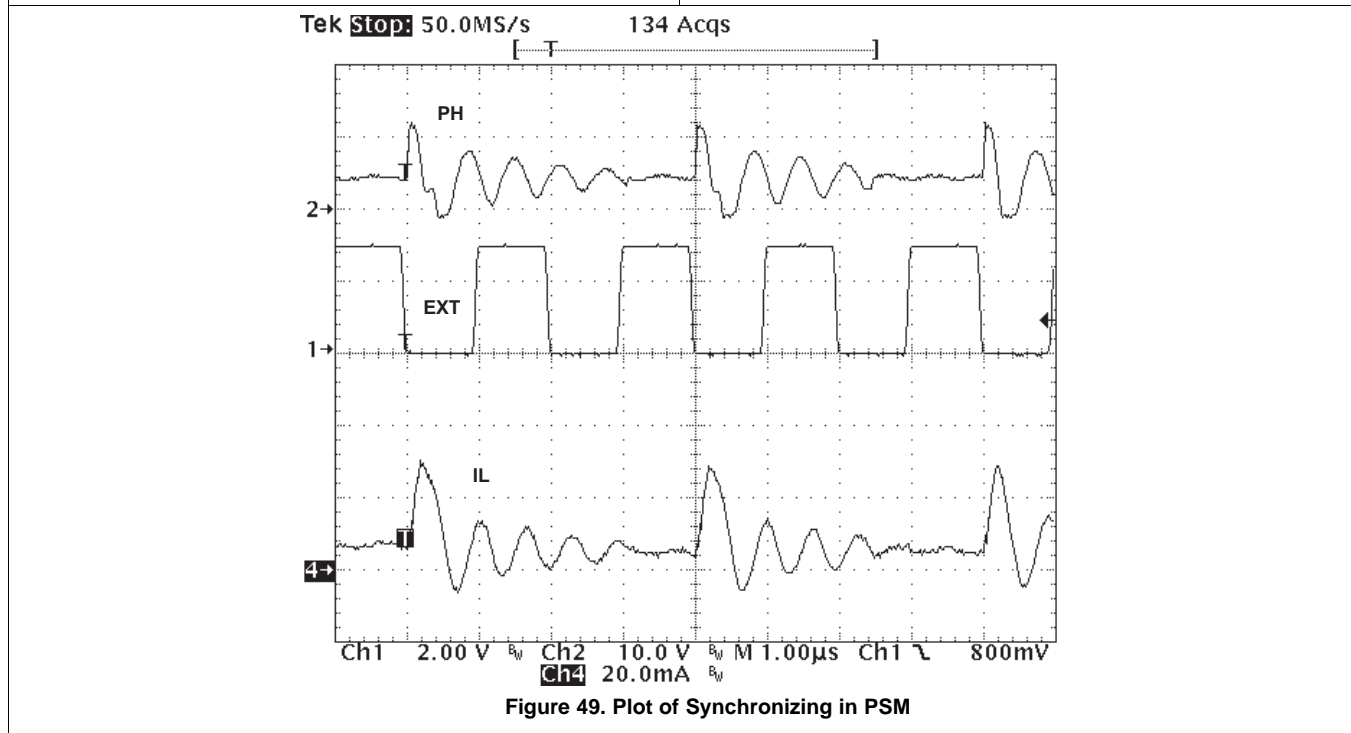
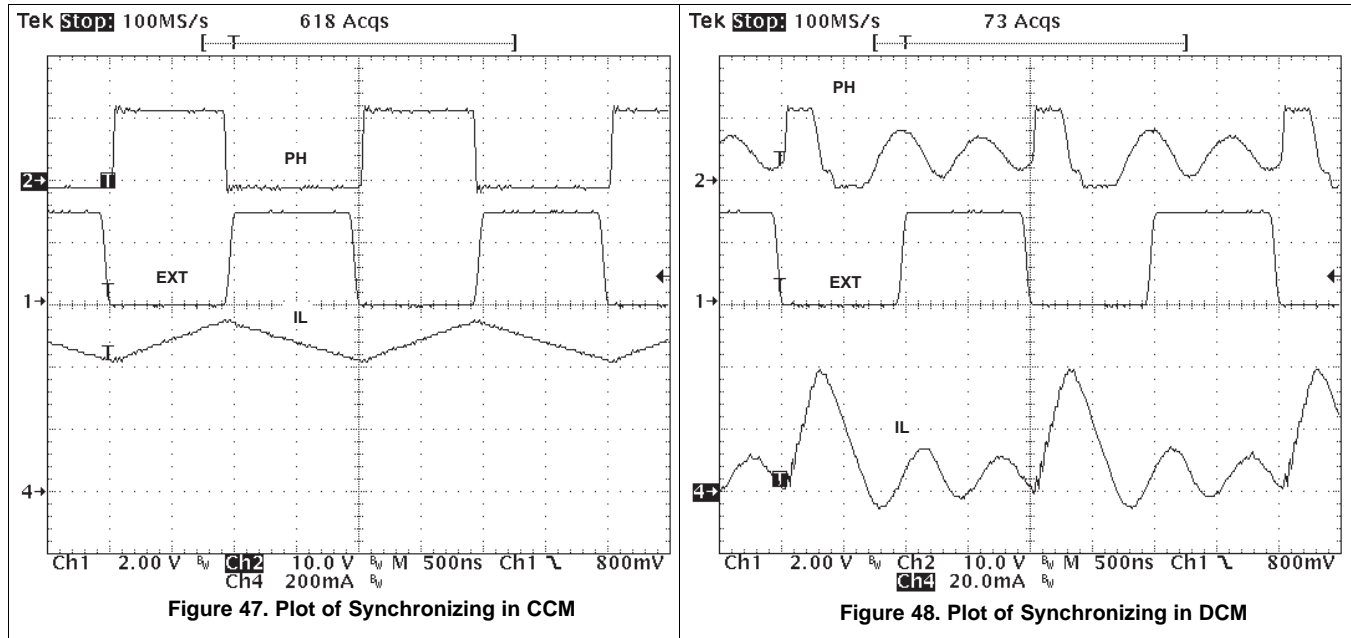

Figure 46. Synchronizing to a System Clock

Application Information (continued)



8.2 Typical Applications

8.2.1 Buck Converter for 3.3-V Output

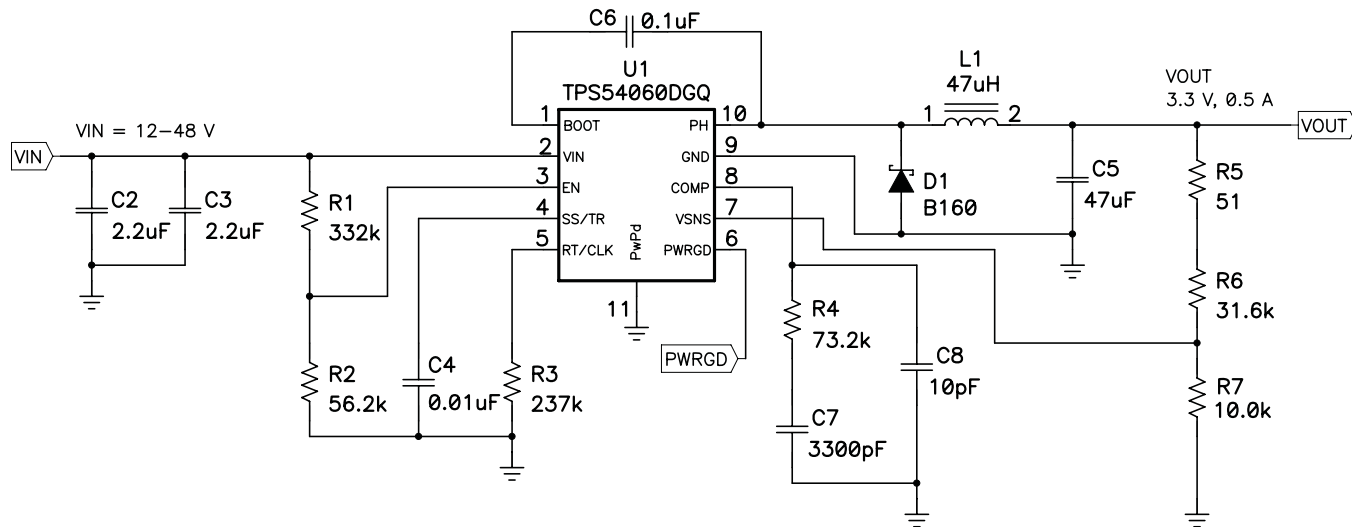

Figure 50. High Frequency, 3.3V Output Power Supply Design with Adjusted UVLO

8.2.1.1 Design Requirements

This example details the design of a high frequency switching regulator design using ceramic output capacitors. A few parameters must be known in order to start the design process. These parameters are typically determined at the system level. For this example, we will start with the following known parameters:

Table 1. Design Parameters

DESIGN PARAMETERS	EXAMPLE VALUES
Output Voltage	3.3 V
Transient Response 0 to 0.5-A load step	$\Delta V_{out} = 4\%$
Maximum Output Current	0.5 A
Input Voltage	34 V nom. 12 V to 48 V
Output Voltage Ripple	1% of V_{out}
Start Input Voltage (rising VIN)	8.9 V
Stop Input Voltage (falling VIN)	7.9 V

8.2.1.2 Detailed Design Procedure

8.2.1.2.1 Selecting the Switching Frequency

The first step is to decide on a switching frequency for the regulator. Typically, the user will want to choose the highest switching frequency possible since this will produce the smallest solution size. The high switching frequency allows for lower valued inductors and smaller output capacitors compared to a power supply that switches at a lower frequency. The switching frequency that can be selected is limited by the minimum on-time of the internal power switch, the input voltage and the output voltage and the frequency shift limitation.

Equation 26 and Equation 27 must be used to find the maximum switching frequency for the regulator, choose the lower value of the two equations. Switching frequencies higher than these values will result in pulse skipping or the lack of overcurrent protection during a short circuit.

The typical minimum on time, t_{onmin} , is 130 ns for the TPS54060. For this example, the output voltage is 3.3 V and the maximum input voltage is 48 V, which allows for a maximum switch frequency up to 616 kHz when including the inductor resistance, on resistance and diode voltage in Equation 26. To ensure overcurrent runaway is not a concern during short circuits in your design use Equation 27 or the solid curve in Figure 45 to determine the maximum switching frequency. With a maximum input voltage of 48 V, assuming a diode voltage of 0.5 V, inductor resistance of 130mΩ, switch resistance of 400mΩ, a current limit value of 0.94 A and a short circuit output voltage of 0.1V. The maximum switching frequency is approximately 923 kHz.

Choosing the lower of the two values and adding some margin a switching frequency of 500kHz is used. To determine the timing resistance for a given switching frequency, use Equation 2 or the curve in Figure 29.

The switching frequency is set by resistor R_3 shown in Figure 50.

8.2.1.2.2 Output Inductor Selection (L_o)

To calculate the minimum value of the output inductor, use Equation 28.

K_{IND} is a coefficient that represents the amount of inductor ripple current relative to the maximum output current.

The inductor ripple current will be filtered by the output capacitor. Therefore, choosing high inductor ripple currents will impact the selection of the output capacitor since the output capacitor must have a ripple current rating equal to or greater than the inductor ripple current. In general, the inductor ripple value is at the discretion of the designer; however, the following guidelines may be used.

For designs using low ESR output capacitors such as ceramics, a value as high as $K_{IND} = 0.3$ may be used. When using higher ESR output capacitors, $K_{IND} = 0.2$ yields better results. Since the inductor ripple current is part of the PWM control system, the inductor ripple current should always be greater than 30 mA for dependable operation. In a wide input voltage regulator, it is best to choose an inductor ripple current on the larger side. This allows the inductor to still have a measurable ripple current with the input voltage at its minimum.

For this design example, use $K_{IND} = 0.3$ and the minimum inductor value is calculated to be 39.7 μ H. For this design, a nearest standard value was chosen: 47 μ H. For the output filter inductor, it is important that the RMS current and saturation current ratings not be exceeded. The RMS and peak inductor current can be found from Equation 30 and Equation 31.

For this design, the RMS inductor current is 0.501 A and the peak inductor current is 0.563 A. The chosen inductor is a MSS1048-473ML. It has a saturation current rating of 1.44 A and an RMS current rating of 1.83A.

As the equation set demonstrates, lower ripple currents will reduce the output voltage ripple of the regulator but will require a larger value of inductance. Selecting higher ripple currents will increase the output voltage ripple of the regulator but allow for a lower inductance value.

The current flowing through the inductor is the inductor ripple current plus the output current. During power up, faults or transient load conditions, the inductor current can increase above the calculated peak inductor current level calculated above. In transient conditions, the inductor current can increase up to the switch current limit of the device. For this reason, the most conservative approach is to specify an inductor with a saturation current rating equal to or greater than the switch current limit rather than the peak inductor current.

$$L_o \text{ min} = \frac{V_{inmax} - V_{out}}{I_o \times K_{IND}} \times \frac{V_{out}}{V_{inmax} \times f_{sw}} \quad (28)$$

$$I_{RIPPLE} = \frac{V_{OUT} \times (V_{inmax} - V_{OUT})}{V_{inmax} \times L_o \times f_{SW}} \quad (29)$$

$$I_{L(rms)} = \sqrt{\left(I_o\right)^2 + \frac{1}{12} \times \left(\frac{V_{OUT} \times (V_{inmax} - V_{OUT})}{V_{inmax} \times L_o \times f_{SW}}\right)^2} \quad (30)$$

$$I_{Lpeak} = I_{out} + \frac{I_{ripple}}{2} \quad (31)$$

8.2.1.2.3 Output Capacitor

There are three primary considerations for selecting the value of the output capacitor. The output capacitor will determine the modulator pole, the output voltage ripple, and how the regulator responds to a large change in load current. The output capacitance needs to be selected based on the more stringent of these three criteria.

The desired response to a large change in the load current is the first criteria. The output capacitor needs to supply the load with current when the regulator can not. This situation would occur if there are desired hold-up times for the regulator where the output capacitor must hold the output voltage above a certain level for a specified amount of time after the input power is removed. The regulator also will temporarily not be able to supply sufficient output current if there is a large, fast increase in the current needs of the load such as transitioning from no load to a full load. The regulator usually needs two or more clock cycles for the control loop to see the change in load current and output voltage and adjust the duty cycle to react to the change. The output capacitor must be sized to supply the extra current to the load until the control loop responds to the load change. The output capacitance must be large enough to supply the difference in current for 2 clock cycles while only allowing a tolerable amount of droop in the output voltage. Equation 32 shows the minimum output capacitance necessary to accomplish this.

For this example, the transient load response is specified as a 4% change in V_{out} for a load step from 0A (no load) to 0.5 A (full load). For this example, $\Delta I_{out} = 0.5 - 0 = 0.5$ A and $\Delta V_{out} = 0.04 \times 3.3 = 0.132$ V. Using these numbers gives a minimum capacitance of 15.2 μ F. This value does not take the ESR of the output capacitor into account in the output voltage change. For ceramic capacitors, the ESR is usually small enough to ignore in this calculation. Aluminum electrolytic and tantalum capacitors have higher ESR that should be taken into account.

The catch diode of the regulator can not sink current so any stored energy in the inductor will produce an output voltage overshoot when the load current rapidly decreases, see Figure 51. The output capacitor must also be sized to absorb energy stored in the inductor when transitioning from a high load current to a lower load current. The excess energy that gets stored in the output capacitor will increase the voltage on the capacitor. The capacitor must be sized to maintain the desired output voltage during these transient periods. Equation 33 is used to calculate the minimum capacitance to keep the output voltage overshoot to a desired value. For this example, the worst case load step will be from 0.5 A to 0 A. The output voltage will increase during this load transition and the stated maximum in our specification is 4% of the output voltage. This will make $V_f = 1.04 \times 3.3 = 3.432$. V_i is the initial capacitor voltage which is the nominal output voltage of 3.3 V. Using these numbers in Equation 33 yields a minimum capacitance of 13.2 μ F.

Equation 34 calculates the minimum output capacitance needed to meet the output voltage ripple specification. Where f_{sw} is the switching frequency, V_{ripple} is the maximum allowable output voltage ripple, and I_{ripple} is the inductor ripple current. Equation 34 yields 1 μ F.

Equation 35 calculates the maximum ESR an output capacitor can have to meet the output voltage ripple specification. Equation 35 indicates the ESR should be less than 248m Ω .

The most stringent criteria for the output capacitor is 15.2 μ F of capacitance to keep the output voltage in regulation during an load transient.

Additional capacitance de-ratings for aging, temperature and dc bias should be factored in which will increase this minimum value. For this example, a 47 μ F 10V X5R ceramic capacitor with 5 m Ω of ESR will be used.

Capacitors generally have limits to the amount of ripple current they can handle without failing or producing excess heat. An output capacitor that can support the inductor ripple current must be specified. Some capacitor data sheets specify the Root Mean Square (RMS) value of the maximum ripple current. Equation 36 can be used to calculate the RMS ripple current the output capacitor needs to support. For this application, Equation 36 yields 37.7 mA.

$$C_{out} > \frac{2 \times \Delta I_{out}}{f_{sw} \times \Delta V_{out}}$$

where

- ΔI_{out} is the change in output current.
- f_{sw} is the regulators switching frequency.
- ΔV_{out} is the allowable change in the output voltage.

(32)

$$C_{out} > L_o \times \frac{(I_{OH}^2 - I_{OL}^2)}{(V_f^2 - V_i^2)}$$

where

- L is the value of the inductor.
- I_{OH} is the output current under heavy load.
- I_{OL} is the output under light load.
- V_F is the final peak output voltage.
- V_i is the initial capacitor voltage.

(33)

$$C_{out} > \frac{1}{8 \times f_{sw}} \times \frac{1}{\frac{V_{ORIPPLE}}{I_{RIPPLE}}}$$

(34)

$$R_{ESR} < \frac{V_{ORIPPLE}}{I_{RIPPLE}}$$

(35)

$$I_{corms} = \frac{V_{out} \times (V_{in\ max} - V_{out})}{\sqrt{12} \times V_{in\ max} \times L_o \times f_{sw}}$$

(36)

8.2.1.2.4 Catch Diode

The TPS54060 requires an external catch diode between the PH pin and GND. The selected diode must have a reverse voltage rating equal to or greater than V_{inmax}. The peak current rating of the diode must be greater than the maximum inductor current. The diode should also have a low forward voltage. Schottky diodes are typically a good choice for the catch diode due to their low forward voltage. The lower the forward voltage of the diode, the higher the efficiency of the regulator.

Typically, the higher the voltage and current ratings the diode has, the higher the forward voltage will be. Since the design example has an input voltage up to 48V, a diode with a minimum of 60V reverse voltage will be selected.

For the example design, the B160A Schottky diode is selected for its lower forward voltage and it comes in a larger package size which has good thermal characteristics over small devices. The typical forward voltage of the B160A is 0.50 volts.

The diode must also be selected with an appropriate power rating. The diode conducts the output current during the off-time of the internal power switch. The off-time of the internal switch is a function of the maximum input voltage, the output voltage, and the switching frequency. The output current during the off-time is multiplied by the forward voltage of the diode which equals the conduction losses of the diode. At higher switch frequencies, the ac losses of the diode need to be taken into account. The ac losses of the diode are due to the charging and discharging of the junction capacitance and reverse recovery. Equation 37 is used to calculate the total power dissipation, conduction losses plus ac losses, of the diode.

The B160A has a junction capacitance of 110pF. Using Equation 37, the selected diode will dissipate 0.297 Watts. This power dissipation, depending on mounting techniques, should produce a 5.9°C temperature rise in the diode when the input voltage is 48V and the load current is 0.5A.

If the power supply spends a significant amount of time at light load currents or in sleep mode consider using a diode which has a low leakage current and slightly higher forward voltage drop.

$$P_d = \frac{(V_{in\ max} - V_{out}) \times I_{out} \times V_{fd}}{V_{in\ max}} + \frac{C_j \times f_{sw} \times (V_{in} + V_{fd})^2}{2}$$

(37)

8.2.1.2.5 Input Capacitor

The TPS54060 requires a high quality ceramic, type X5R or X7R, input decoupling capacitor of at least 3 μF of effective capacitance and in some applications a bulk capacitance. The effective capacitance includes any dc bias effects. The voltage rating of the input capacitor must be greater than the maximum input voltage. The capacitor must also have a ripple current rating greater than the maximum input current ripple of the TPS54060. The input ripple current can be calculated using [Equation 38](#).

The value of a ceramic capacitor varies significantly over temperature and the amount of dc bias applied to the capacitor. The capacitance variations due to temperature can be minimized by selecting a dielectric material that is stable over temperature. X5R and X7R ceramic dielectrics are usually selected for power regulator capacitors because they have a high capacitance to volume ratio and are fairly stable over temperature. The output capacitor must also be selected with the dc bias taken into account. The capacitance value of a capacitor decreases as the dc bias across a capacitor increases.

For this example design, a ceramic capacitor with at least a 60V voltage rating is required to support the maximum input voltage. Common standard ceramic capacitor voltage ratings include 4V, 6.3V, 10V, 16V, 25V, 50V or 100V so a 100V capacitor should be selected. For this example, two 2.2 μF , 100V capacitors in parallel have been selected. [Table 2](#) shows a selection of high voltage capacitors. The input capacitance value determines the input ripple voltage of the regulator. The input voltage ripple can be calculated using [Equation 39](#). Using the design example values, $I_{\text{out max}} = 0.5 \text{ A}$, $C_{\text{in}} = 4.4\mu\text{F}$, $f_{\text{sw}} = 500 \text{ kHz}$, yields an input voltage ripple of 57 mV and a rms input ripple current of 0.223A.

$$I_{\text{cirms}} = I_{\text{out}} \times \sqrt{\frac{V_{\text{out}}}{V_{\text{in min}}} \times \frac{(V_{\text{in min}} - V_{\text{out}})}{V_{\text{in min}}}} \quad (38)$$

$$\Delta V_{\text{in}} = \frac{I_{\text{out max}} \times 0.25}{C_{\text{in}} \times f_{\text{sw}}} \quad (39)$$

Table 2. Capacitor Types

VENDOR	VALUE (μF)	EIA Size	VOLTAGE	DIELECTRIC	COMMENTS
Murata	1.0 to 2.2	1210	100 V	X7R	GRM32 series
	1.0 to 4.7		50 V		
	1.0	1206	100 V		GRM31 series
	1.0 to 2.2		50 V		
Vishay	1.0 10 1.8	2220	50 V		VJ X7R series
	1.0 to 1.2		100 V		
	1.0 to 3.9	2225	50 V		
	1.0 to 1.8		100 V		
TDK	1.0 to 2.2	1812	100 V		C series C4532
	1.5 to 6.8		50 V		
	1.0. to 2.2	1210	100 V	C series C3225	
	1.0 to 3.3		50 V		
AVX	1.0 to 4.7	1210	50 V	X7R dielectric series	
	1.0		100 V		
	1.0 to 4.7	1812	50 V		
	1.0 to 2.2		100 V		

8.2.1.2.6 Slow Start Capacitor

The slow start capacitor determines the minimum amount of time it will take for the output voltage to reach its nominal programmed value during power up. This is useful if a load requires a controlled voltage slew rate. This is also used if the output capacitance is large and would require large amounts of current to quickly charge the capacitor to the output voltage level. The large currents necessary to charge the capacitor may make the TPS54060 reach the current limit or excessive current draw from the input power supply may cause the input voltage rail to sag. Limiting the output voltage slew rate solves both of these problems.

The slow start time must be long enough to allow the regulator to charge the output capacitor up to the output voltage without drawing excessive current. Equation 40 can be used to find the minimum slow start time, t_{ss} , necessary to charge the output capacitor, C_{out} , from 10% to 90% of the output voltage, V_{out} , with an average slow start current of I_{ssavg} . In the example, to charge the 47 μ F output capacitor up to 3.3V while only allowing the average input current to be 0.125A would require a 1 ms slow start time.

Once the slow start time is known, the slow start capacitor value can be calculated using Equation 1. For the example circuit, the slow start time is not too critical since the output capacitor value is 47 μ F which does not require much current to charge to 3.3V. The example circuit has the slow start time set to an arbitrary value of 3.2ms which requires a 0.01 μ F capacitor.

$$t_{ss} > \frac{C_{out} \times V_{out} \times 0.8}{I_{ssavg}} \quad (40)$$

8.2.1.2.7 Bootstrap Capacitor Selection

A 0.1- μ F ceramic capacitor must be connected between the BOOT and PH pins for proper operation. It is recommended to use a ceramic capacitor with X5R or better grade dielectric. The capacitor should have a 10V or higher voltage rating.

8.2.1.2.8 Undervoltage Lockout (UVLO) Set Point

The UVLO can be adjusted using an external voltage divider on the EN pin of the TPS54060. The UVLO has two thresholds, one for power up when the input voltage is rising and one for power down or brown outs when the input voltage is falling. For the example design, the supply should turn on and start switching once the input voltage increases above 8.9V (enabled). After the regulator starts switching, it should continue to do so until the input voltage falls below 7.9V (UVLO stop).

The programmable UVLO and enable voltages are set using a resistor divider between V_{in} and ground to the EN pin. Equation 18 through Equation 19 can be used to calculate the resistance values necessary. For the example application, a 332k Ω between V_{in} and EN and a 56.2k Ω between EN and ground are required to produce the 8.9 and 7.9 volt start and stop voltages.

8.2.1.2.9 Output Voltage and Feedback Resistors Selection

For the example design, 10.0 k Ω was selected for R2. Using Equation 17, R1 is calculated as 31.25 k Ω . The nearest standard 1% resistor is 31.6 k Ω . Due to current leakage of the VSENSE pin, the current flowing through the feedback network should be greater than 1 μ A in order to maintain the output voltage accuracy. This requirement makes the maximum value of R2 equal to 800 k Ω . Choosing higher resistor values will decrease quiescent current and improve efficiency at low output currents but may introduce noise immunity problems.

8.2.1.2.10 Compensation

There are several methods used to compensate DC/DC regulators. The method presented here is easy to calculate and ignores the effects of the slope compensation that is internal to the device. Since the slope compensation is ignored, the actual cross over frequency will usually be lower than the cross over frequency used in the calculations. This method assume the crossover frequency is between the modulator pole and the esr zero and the esr zero is at least 10 times greater the modulator pole. Use SwitcherPro software for a more accurate design.

To get started, the modulator pole, f_{pmod} , and the esr zero, f_{z1} must be calculated using Equation 41 and Equation 42. For C_{out} , use a derated value of 40 μ F. Use equations Equation 43 and Equation 44, to estimate a starting point for the crossover frequency, f_{co} , to design the compensation. For the example design, f_{pmod} is 603 Hz and f_{zmod} is 796 kHz. Equation 43 is the geometric mean of the modulator pole and the esr zero and Equation 44 is the mean of modulator pole and the switching frequency. Equation 43 yields 21.9 kHz and Equation 44 gives 12.3 kHz. Use the lower value of Equation 43 or Equation 44 for an initial crossover frequency. For this example, f_{co} is 12.3kHz. Next, the compensation components are calculated. A resistor in series with a capacitor is used to create a compensating zero. A capacitor in parallel to these two components forms the compensating pole.

$$f_{p\ mod} = \frac{I_{outmax}}{2 \times \pi \times V_{out} \times C_{out}} \quad (41)$$

$$f_z \text{ mod} = \frac{1}{2 \times \pi \times \text{Resr} \times \text{Cout}} \quad (42)$$

$$f_{co} = \sqrt{f_p \text{ mod} \times f_z \text{ mod}} \quad (43)$$

$$f_{co} = \sqrt{f_p \text{ mod} \times \frac{f_{sw}}{2}} \quad (44)$$

To determine the compensation resistor, R4, use [Equation 45](#). Assume the power stage transconductance, g_{mps} , is 1.9A/V. The output voltage, V_o , reference voltage, V_{REF} , and amplifier transconductance, g_{mea} , are 3.3V, 0.8V and 97 μ S, respectively. R4 is calculated to be 72.6 k Ω , use the nearest standard value of 73.2k Ω . Use [Equation 46](#) to set the compensation zero to the modulator pole frequency. [Equation 46](#) yields 3600pF for compensating capacitor C7, a 3300pF is used on the board.

$$R4 = \left(\frac{2 \times \pi \times f_{co} \times C_{out}}{g_{mps}} \right) \times \left(\frac{V_{out}}{V_{ref} \times g_{mea}} \right) \quad (45)$$

$$C7 = \frac{1}{2 \times \pi \times R4 \times f_p \text{ mod}} \quad (46)$$

Use the larger value of [Equation 47](#) and [Equation 48](#) to calculate the C8, to set the compensation pole. [Equation 48](#) yields 8.7pF so the nearest standard of 10pF is used.

$$C8 = \frac{C_o \times \text{Resr}}{R4} \quad (47)$$

$$C8 = \frac{1}{R4 \times f_{sw} \times \pi} \quad (48)$$

8.2.1.2.11 Discontinuous Mode and Eco Mode Boundary

With an input voltage of 34V, the power supply enters discontinuous mode when the output current is less than 60mA. The power supply enters EcoMode when the output current is lower than 38mA.

The input current draw at no load is 228 μ A.

8.2.1.2.12 Power Dissipation Estimate

The following formulas show how to estimate the IC power dissipation under continuous conduction mode (CCM) operation. These equations should not be used if the device is working in discontinuous conduction mode (DCM).

The power dissipation of the IC includes conduction loss (Pcon), switching loss (Psw), gate drive loss (Pgd) and supply current (Pq).

$$P_{con} = I_o^2 \times R_{DS(on)} \times \frac{V_{out}}{V_{in}} \quad (49)$$

$$P_{sw} = V_{in}^2 \times f_{sw} \times I_o \times 0.25 \times 10^{-9} \quad (50)$$

$$P_{gd} = V_{in} \times 3 \times 10^{-9} \times f_{sw} \quad (51)$$

$$P_q = 116 \times 10^{-6} \times V_{in} \quad (52)$$

Where:

I_o is the output current (A).

$R_{DS(on)}$ is the on-resistance of the high-side MOSFET (Ω).

V_{OUT} is the output voltage (V).

V_{IN} is the input voltage (V).

f_{sw} is the switching frequency (Hz).

So

$$P_{tot} = P_{con} + P_{sw} + P_{gd} + P_q \quad (53)$$

For given T_A ,

$$T_J = T_A + R_{th} \times P_{tot} \tag{54}$$

For given $T_{JMAX} = 150^\circ\text{C}$

$$T_{Amax} = T_{Jmax} - R_{th} \times P_{tot} \tag{55}$$

Where:

P_{tot} is the total device power dissipation (W).

T_A is the ambient temperature ($^\circ\text{C}$).

T_J is the junction temperature ($^\circ\text{C}$).

R_{th} is the thermal resistance junction to ambient for a given PCB layout ($^\circ\text{C}/\text{W}$).

T_{JMAX} is maximum junction temperature ($^\circ\text{C}$).

T_{AMAX} is maximum ambient temperature ($^\circ\text{C}$).

There will be additional power losses in the regulator circuit due to the inductor ac and dc losses, the catch diode and trace resistance that will impact the overall efficiency of the regulator.

8.2.1.3 Application Curves

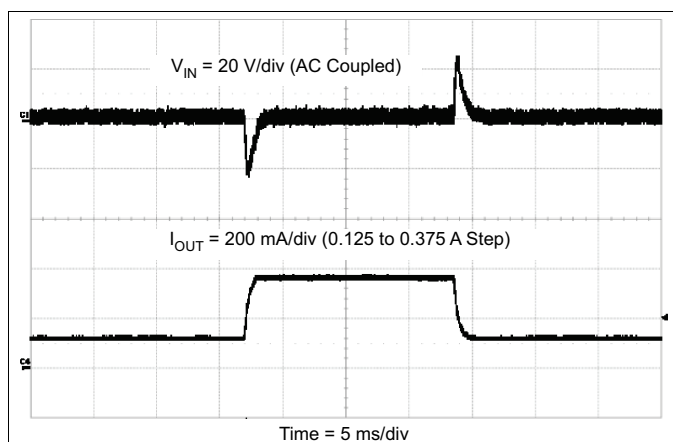

Figure 51. Load Transient

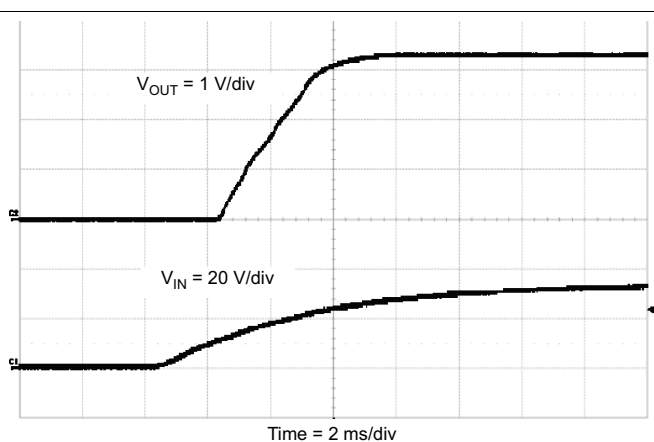

Figure 52. Start-Up With VIN

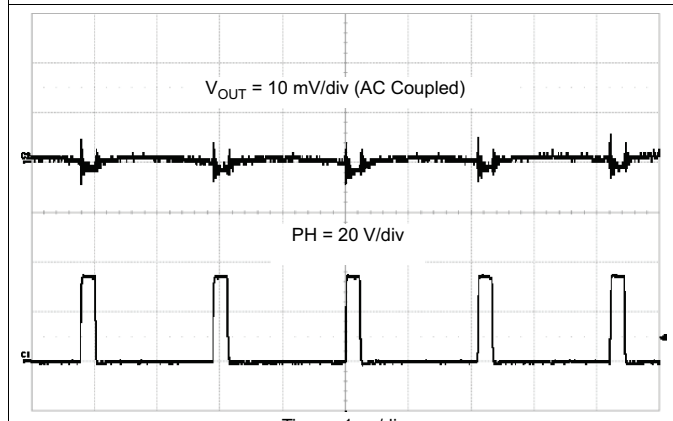

Figure 53. Output Ripple CCM

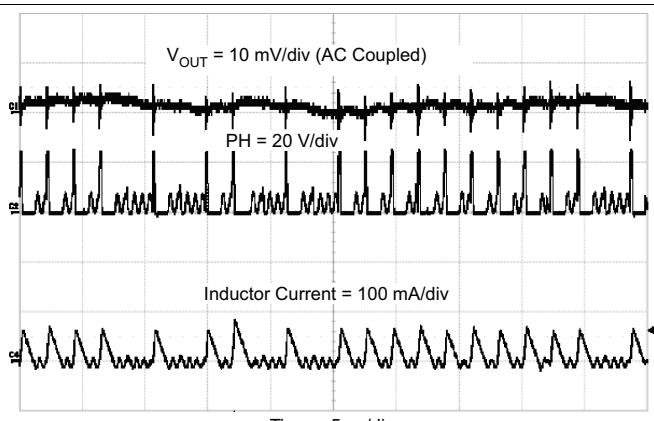

Figure 54. Output Ripple, DCM

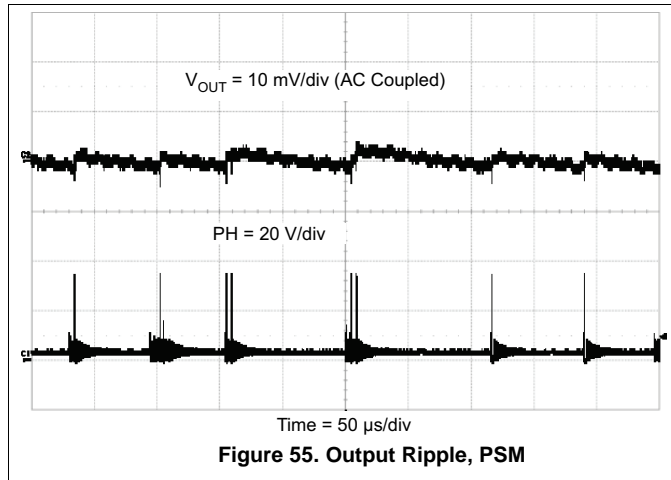

Figure 55. Output Ripple, PSM

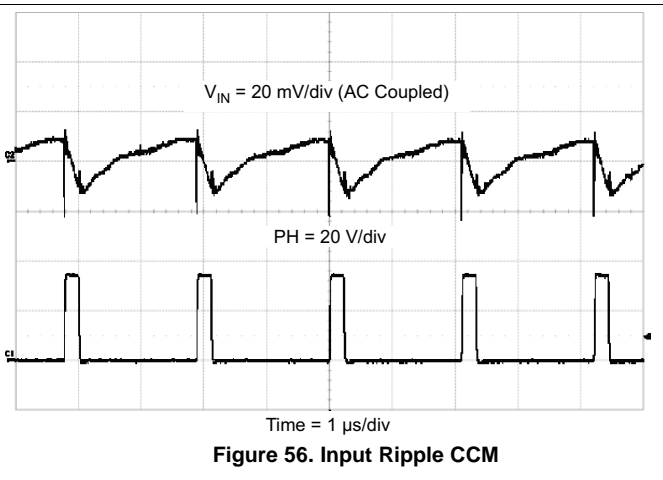

Figure 56. Input Ripple CCM

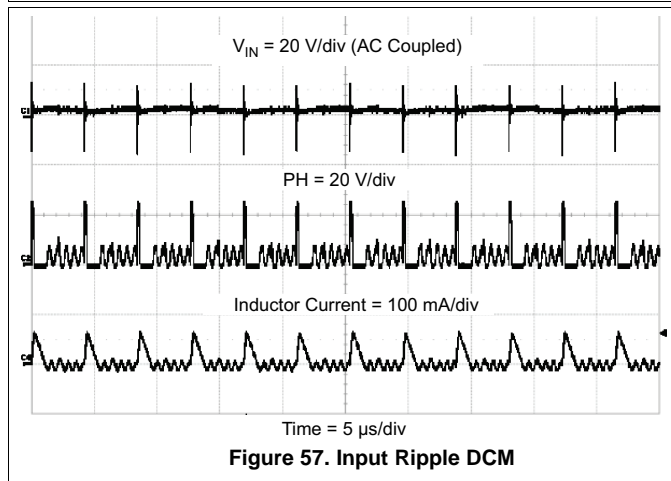

Figure 57. Input Ripple DCM

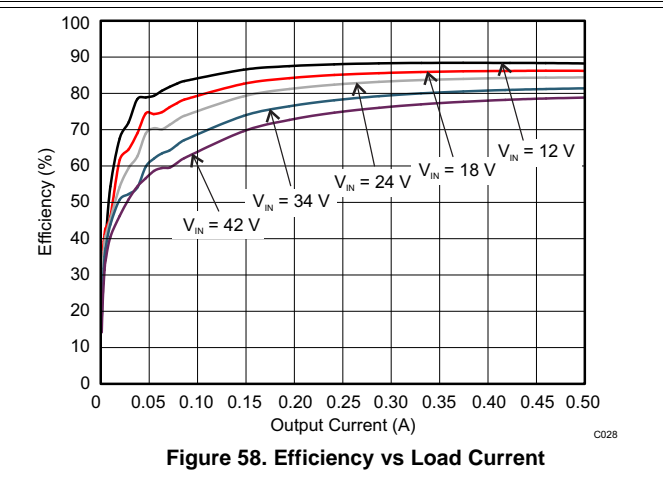

Figure 58. Efficiency vs Load Current

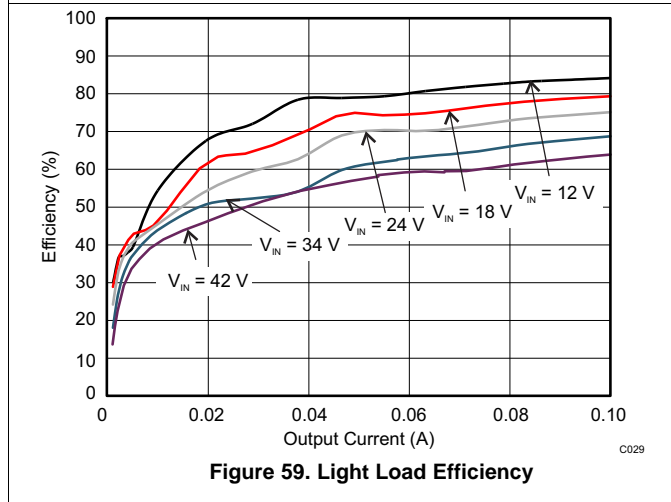

Figure 59. Light Load Efficiency

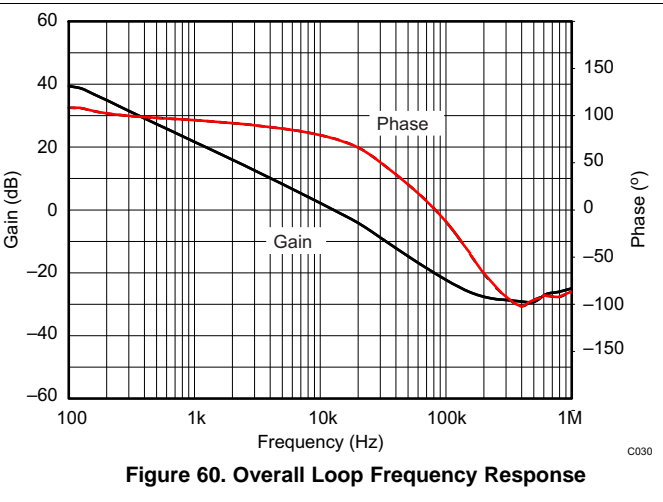
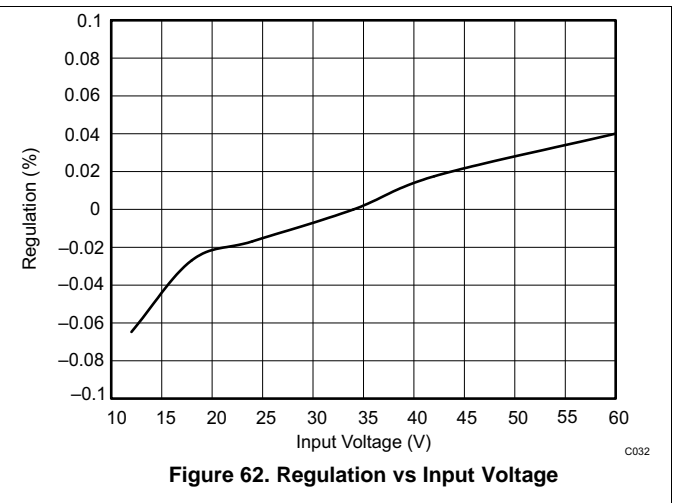
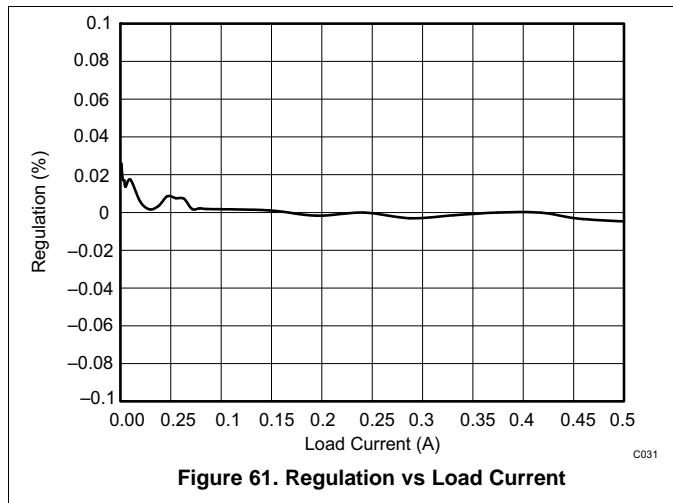

Figure 60. Overall Loop Frequency Response



8.2.2 Inverting Power Supply

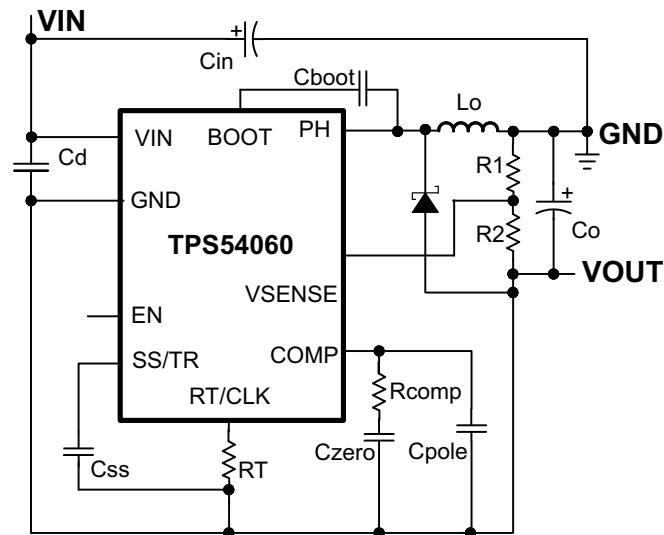

Figure 63. Inverting Power Supply from the [SLVA317](#) Application Note

8.2.3 Split Rail Power Supply

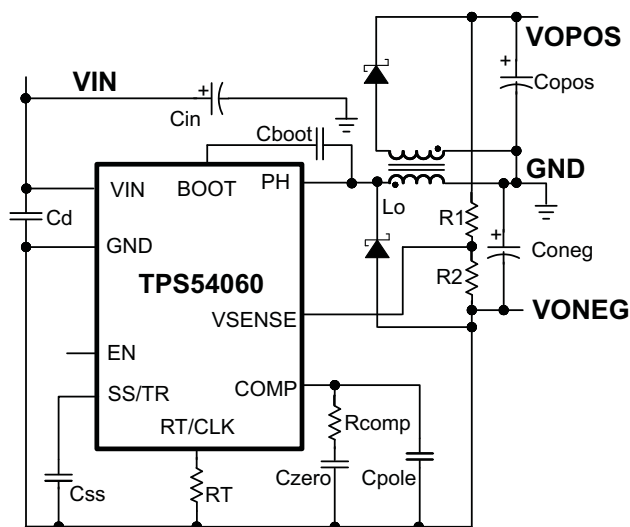

Figure 64. Split Rail Power Supply Based on the [SLVA369](#) Application Note

9 Power Supply Recommendations

The design of the device is for operation from a power supply range between 3.5 V and 60 V. It is essential that the power supply voltage remains within this range. If the power supply is more distant than a few inches from the TPS54060 converter, the circuit may require additional bulk capacitance besides the ceramic bypass capacitors. An electrolytic capacitor with a value of 100 μF is a typical choice.

10 Layout

10.1 Layout Guidelines

Layout is a critical portion of good power supply design. There are several signals paths that conduct fast changing currents or voltages that can interact with stray inductance or parasitic capacitance to generate noise or degrade the power supplies performance. To help eliminate these problems, the VIN pin should be bypassed to ground with a low ESR ceramic bypass capacitor with X5R or X7R dielectric. Care should be taken to minimize the loop area formed by the bypass capacitor connections, the VIN pin, and the anode of the catch diode. See Figure 65 for a PCB layout example. The GND pin should be tied directly to the power pad under the IC and the power pad.

The power pad should be connected to any internal PCB ground planes using multiple vias directly under the IC. The PH pin should be routed to the cathode of the catch diode and to the output inductor. Since the PH connection is the switching node, the catch diode and output inductor should be located close to the PH pins, and the area of the PCB conductor minimized to prevent excessive capacitive coupling. For operation at full rated load, the top side ground area must provide adequate heat dissipating area. The RT/CLK pin is sensitive to noise so the RT resistor should be located as close as possible to the IC and routed with minimal lengths of trace. The additional external components can be placed approximately as shown. It may be possible to obtain acceptable performance with alternate PCB layouts, however this layout has been shown to produce good results and is meant as a guideline.

10.1.1 Estimated Circuit Area

The estimated printed circuit board area for the components used in the design of Figure 50 is 0.55 in². This area does not include test points or connectors.

10.2 Layout Example

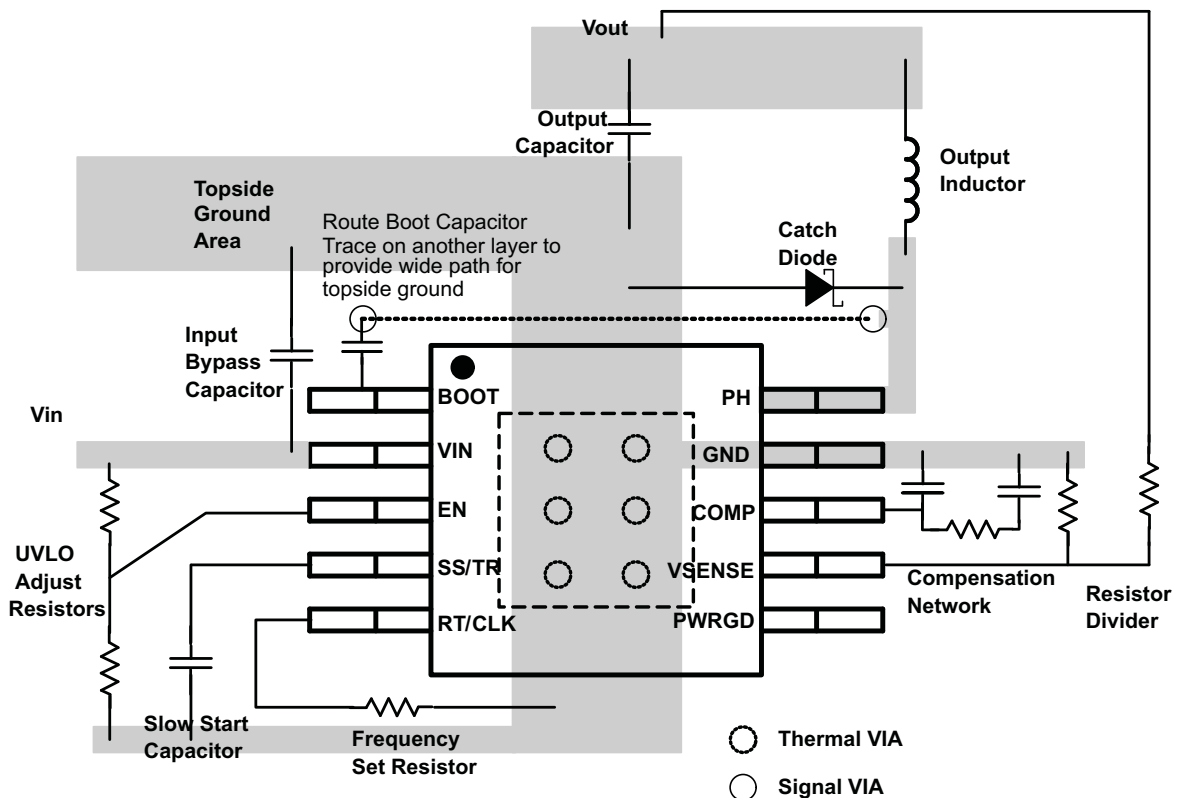

Figure 65. PCB Layout Example

11 Device and Documentation Support

11.1 Device Support

11.1.1 Third-Party Products Disclaimer

TI'S PUBLICATION OF INFORMATION REGARDING THIRD-PARTY PRODUCTS OR SERVICES DOES NOT CONSTITUTE AN ENDORSEMENT REGARDING THE SUITABILITY OF SUCH PRODUCTS OR SERVICES OR A WARRANTY, REPRESENTATION OR ENDORSEMENT OF SUCH PRODUCTS OR SERVICES, EITHER ALONE OR IN COMBINATION WITH ANY TI PRODUCT OR SERVICE.

11.1.2 Development Support

For the TPS54060 and TPS54060A family Excel design tool, see [SLVC432](#).

11.2 Documentation Support

11.2.1 Related Documentation

For related documentation, see the following:

- *TPS54060EVM-457 0.5-A, SWIFT(TM) Regulator EVM*, [SLVU299](#)
- *Create an Inverting Power Supply From a Step-Down Regulator*, [SLVA317](#)
- *Level Shifting Control for an Inverting Buck-boost*, [SLVA540](#)
- *Creating a Split-Rail Power Supply With a Wide Input Voltage Buck Regulator*, [SLVA369](#)
- *TPS54060EVM-590 100mA, Split Rail SWIFT™ Regulator Evaluation Module*, [SLVU374](#)
- *Improved Load Current Capability for Cap-Drop Off-Line Power Supply for E-Meter*, [SLVA491](#)

11.3 Trademarks

Eco-Mode, PowerPAD, WEBENCH, SwitcherPro are trademarks of Texas Instruments. Excel is a registered trademark of Microsoft Corporation. All other trademarks are the property of their respective owners.

11.4 Electrostatic Discharge Caution



These devices have limited built-in ESD protection. The leads should be shorted together or the device placed in conductive foam during storage or handling to prevent electrostatic damage to the MOS gates.

11.5 Glossary

[SLYZ022](#) — *TI Glossary*.

This glossary lists and explains terms, acronyms, and definitions.

12 Mechanical, Packaging, and Orderable Information

The following pages include mechanical, packaging, and orderable information. This information is the most current data available for the designated devices. This data is subject to change without notice and revision of this document. For browser-based versions of this data sheet, refer to the left-hand navigation.

PACKAGING INFORMATION

Orderable Device	Status (1)	Package Type	Package Drawing	Pins	Package Qty	Eco Plan (2)	Lead/Ball Finish (6)	MSL Peak Temp (3)	Op Temp (°C)	Device Marking (4/5)	Samples
TPS54060DGQ	ACTIVE	MSOP-PowerPAD	DGQ	10	80	Green (RoHS & no Sb/Br)	CU NIPDAUAG	Level-1-260C-UNLIM	-40 to 150	54060	Samples
TPS54060DGQR	ACTIVE	MSOP-PowerPAD	DGQ	10	2500	Green (RoHS & no Sb/Br)	CU NIPDAUAG	Level-1-260C-UNLIM	-40 to 150	54060	Samples
TPS54060DRCR	ACTIVE	VSON	DRC	10	3000	Green (RoHS & no Sb/Br)	CU NIPDAU	Level-1-260C-UNLIM	-40 to 150	54060	Samples
TPS54060DRCT	ACTIVE	VSON	DRC	10	250	Green (RoHS & no Sb/Br)	CU NIPDAU	Level-1-260C-UNLIM	-40 to 150	54060	Samples

(1) The marketing status values are defined as follows:

ACTIVE: Product device recommended for new designs.

LIFEBUY: TI has announced that the device will be discontinued, and a lifetime-buy period is in effect.

NRND: Not recommended for new designs. Device is in production to support existing customers, but TI does not recommend using this part in a new design.

PREVIEW: Device has been announced but is not in production. Samples may or may not be available.

OBsolete: TI has discontinued the production of the device.

(2) Eco Plan - The planned eco-friendly classification: Pb-Free (RoHS), Pb-Free (RoHS Exempt), or Green (RoHS & no Sb/Br) - please check <http://www.ti.com/productcontent> for the latest availability information and additional product content details.

TBD: The Pb-Free/Green conversion plan has not been defined.

Pb-Free (RoHS): TI's terms "Lead-Free" or "Pb-Free" mean semiconductor products that are compatible with the current RoHS requirements for all 6 substances, including the requirement that lead not exceed 0.1% by weight in homogeneous materials. Where designed to be soldered at high temperatures, TI Pb-Free products are suitable for use in specified lead-free processes.

Pb-Free (RoHS Exempt): This component has a RoHS exemption for either 1) lead-based flip-chip solder bumps used between the die and package, or 2) lead-based die adhesive used between the die and leadframe. The component is otherwise considered Pb-Free (RoHS compatible) as defined above.

Green (RoHS & no Sb/Br): TI defines "Green" to mean Pb-Free (RoHS compatible), and free of Bromine (Br) and Antimony (Sb) based flame retardants (Br or Sb do not exceed 0.1% by weight in homogeneous material)

(3) MSL, Peak Temp. - The Moisture Sensitivity Level rating according to the JEDEC industry standard classifications, and peak solder temperature.

(4) There may be additional marking, which relates to the logo, the lot trace code information, or the environmental category on the device.

(5) Multiple Device Markings will be inside parentheses. Only one Device Marking contained in parentheses and separated by a "~" will appear on a device. If a line is indented then it is a continuation of the previous line and the two combined represent the entire Device Marking for that device.

(6) Lead/Ball Finish - Orderable Devices may have multiple material finish options. Finish options are separated by a vertical ruled line. Lead/Ball Finish values may wrap to two lines if the finish value exceeds the maximum column width.

Important Information and Disclaimer:The information provided on this page represents TI's knowledge and belief as of the date that it is provided. TI bases its knowledge and belief on information provided by third parties, and makes no representation or warranty as to the accuracy of such information. Efforts are underway to better integrate information from third parties. TI has taken and continues to take reasonable steps to provide representative and accurate information but may not have conducted destructive testing or chemical analysis on incoming materials and chemicals. TI and TI suppliers consider certain information to be proprietary, and thus CAS numbers and other limited information may not be available for release.

In no event shall TI's liability arising out of such information exceed the total purchase price of the TI part(s) at issue in this document sold by TI to Customer on an annual basis.

OTHER QUALIFIED VERSIONS OF TPS54060 :

- Automotive: [TPS54060-Q1](#)
- Enhanced Product: [TPS54060-EP](#)

NOTE: Qualified Version Definitions:

- Automotive - Q100 devices qualified for high-reliability automotive applications targeting zero defects
- Enhanced Product - Supports Defense, Aerospace and Medical Applications

TAPE AND REEL INFORMATION

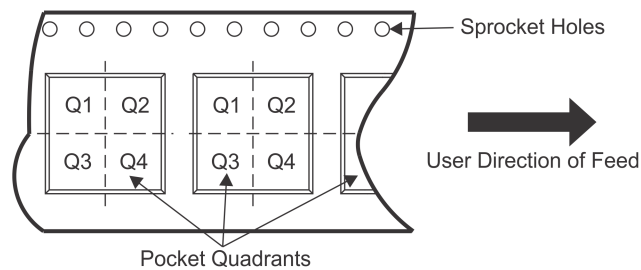
QUADRANT ASSIGNMENTS FOR PIN 1 ORIENTATION IN TAPE

*All dimensions are nominal

Device	Package Type	Package Drawing	Pins	SPQ	Reel Diameter (mm)	Reel Width W1 (mm)	A0 (mm)	B0 (mm)	K0 (mm)	P1 (mm)	W (mm)	Pin1 Quadrant
TPS54060DGQR	MSOP-Power PAD	DGQ	10	2500	330.0	12.4	5.3	3.4	1.4	8.0	12.0	Q1
TPS54060DRCR	VSON	DRC	10	3000	330.0	12.4	3.3	3.3	1.0	8.0	12.0	Q2
TPS54060DRCT	VSON	DRC	10	250	180.0	12.4	3.3	3.3	1.0	8.0	12.0	Q2

TAPE AND REEL BOX DIMENSIONS

*All dimensions are nominal

Device	Package Type	Package Drawing	Pins	SPQ	Length (mm)	Width (mm)	Height (mm)
TPS54060DGQR	MSOP-PowerPAD	DGQ	10	2500	364.0	364.0	27.0
TPS54060DRCR	VSON	DRC	10	3000	346.0	346.0	35.0
TPS54060DRCT	VSON	DRC	10	250	203.0	203.0	35.0

DGQ (S-PDSO-G10)

PowerPAD™ PLASTIC SMALL OUTLINE

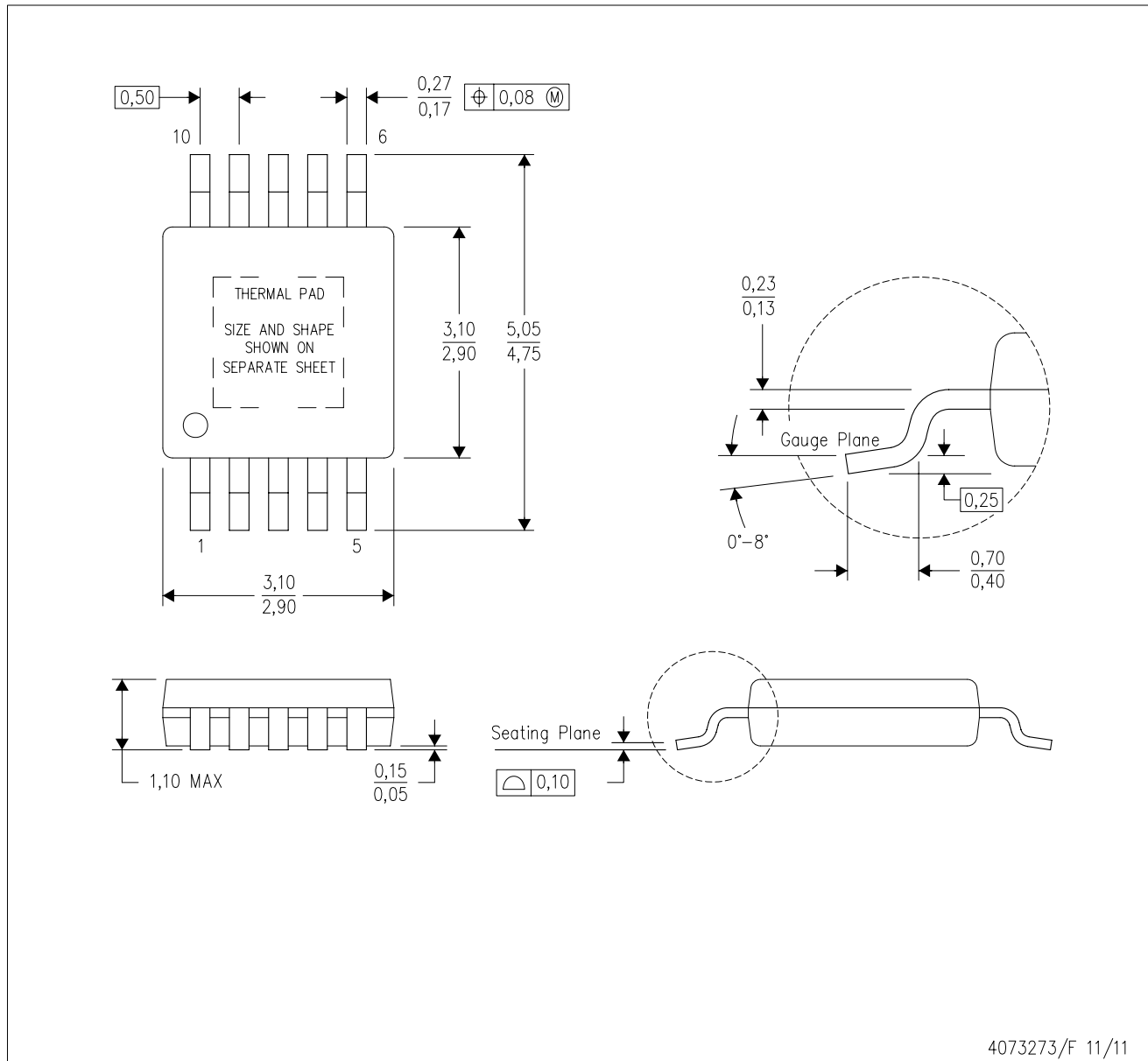

- NOTES:
- A. All linear dimensions are in millimeters.
 - B. This drawing is subject to change without notice.
 - C. Body dimensions do not include mold flash or protrusion not to exceed 0,15.
 - D. This package is designed to be soldered to a thermal pad on the board. Refer to Technical Brief, PowerPad Thermally Enhanced Package, Texas Instruments Literature No. SLMA002 for information regarding recommended board layout. This document is available at www.ti.com <<http://www.ti.com>>.
 - E. See the additional figure in the Product Data Sheet for details regarding the exposed thermal pad features and dimensions.
 - F. Falls within JEDEC MO-187 variation BA-T.

PowerPAD is a trademark of Texas Instruments.

DGQ (S-PDSO-G10)

PowerPAD™ PLASTIC SMALL OUTLINE

THERMAL INFORMATION

This PowerPAD™ package incorporates an exposed thermal pad that is designed to be attached to a printed circuit board (PCB). The thermal pad must be soldered directly to the PCB. After soldering, the PCB can be used as a heatsink. In addition, through the use of thermal vias, the thermal pad can be attached directly to the appropriate copper plane shown in the electrical schematic for the device, or alternatively, can be attached to a special heatsink structure designed into the PCB. This design optimizes the heat transfer from the integrated circuit (IC).

For additional information on the PowerPAD package and how to take advantage of its heat dissipating abilities, refer to Technical Brief, PowerPAD Thermally Enhanced Package, Texas Instruments Literature No. SLMA002 and Application Brief, PowerPAD Made Easy, Texas Instruments Literature No. SLMA004. Both documents are available at www.ti.com.

The exposed thermal pad dimensions for this package are shown in the following illustration.

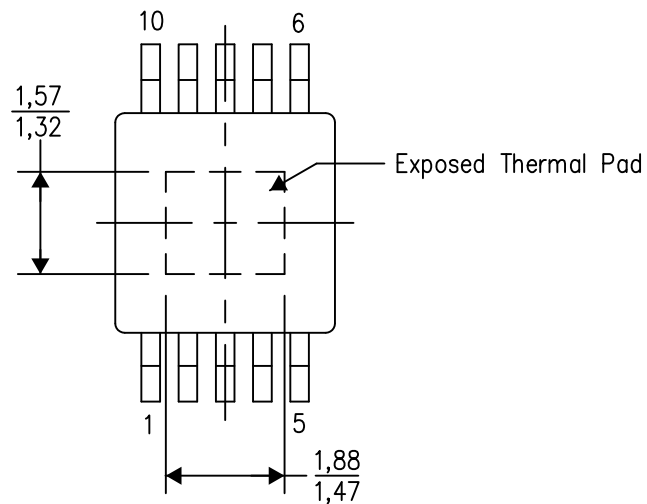

Top View

Exposed Thermal Pad Dimensions

4206324-2/H 12/14

NOTE: A. All linear dimensions are in millimeters

PowerPAD is a trademark of Texas Instruments

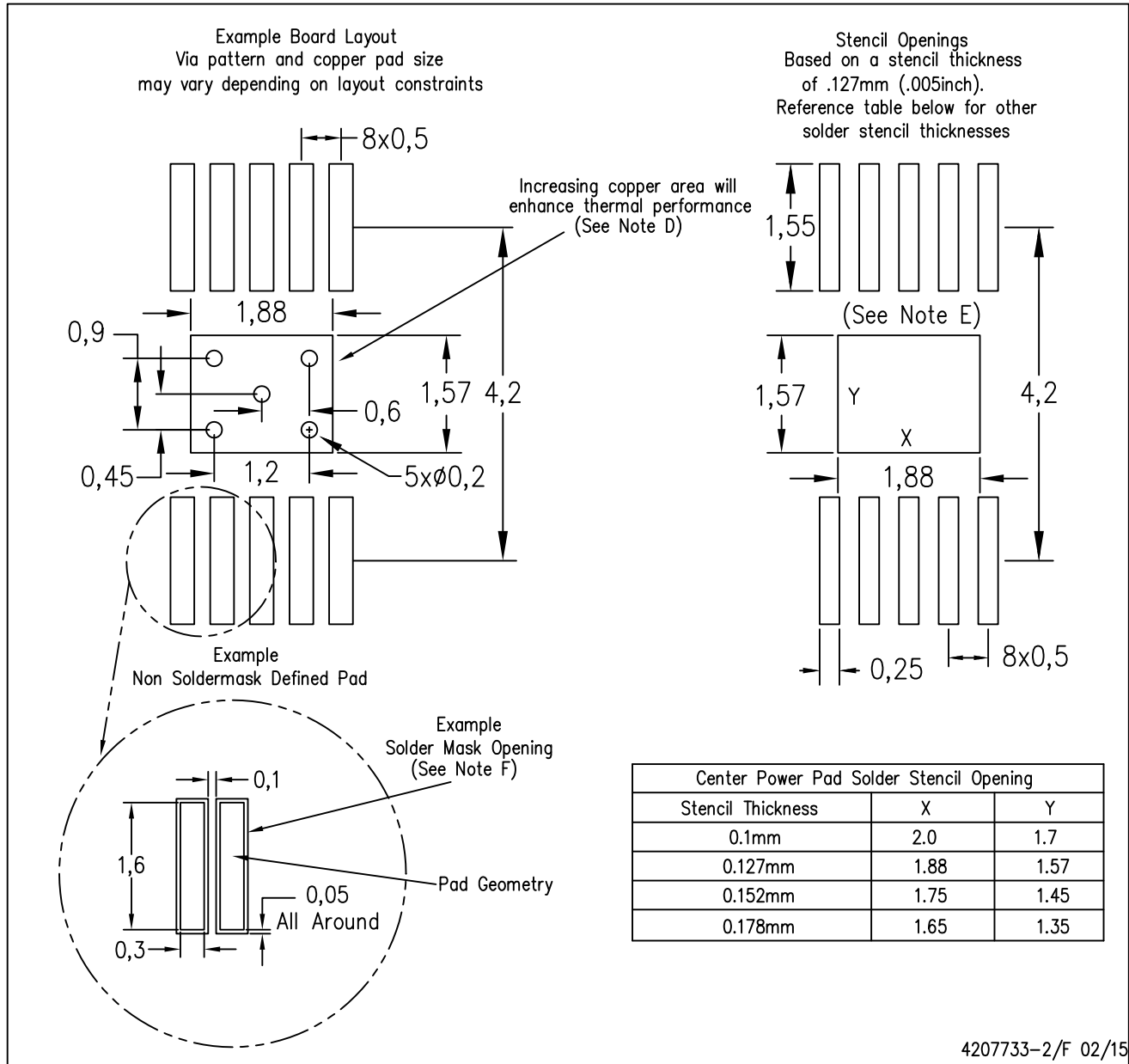

- NOTES:
- All linear dimensions are in millimeters.
 - This drawing is subject to change without notice.
 - Customers should place a note on the circuit board fabrication drawing not to alter the center solder mask defined pad.
 - This package is designed to be soldered to a thermal pad on the board. Refer to Technical Brief, PowerPad Thermally Enhanced Package, Texas Instruments Literature No. SLMA002, SLMA004, and also the Product Data Sheets for specific thermal information, via requirements, and recommended board layout. These documents are available at www.ti.com <<http://www.ti.com>>. Publication IPC-7351 is recommended for alternate designs.
 - Laser cutting apertures with trapezoidal walls and also rounding corners will offer better paste release. Customers should contact their board assembly site for stencil design recommendations. Example stencil design based on a 50% volumetric metal load solder paste. Refer to IPC-7525 for other stencil recommendations.
 - Customers should contact their board fabrication site for solder mask tolerances between and around signal pads.

PowerPAD is a trademark of Texas Instruments

DGQ (S-PDSO-G10)

PowerPAD™ PLASTIC SMALL OUTLINE

THERMAL INFORMATION

This PowerPAD™ package incorporates an exposed thermal pad that is designed to be attached to a printed circuit board (PCB). The thermal pad must be soldered directly to the PCB. After soldering, the PCB can be used as a heatsink. In addition, through the use of thermal vias, the thermal pad can be attached directly to the appropriate copper plane shown in the electrical schematic for the device, or alternatively, can be attached to a special heatsink structure designed into the PCB. This design optimizes the heat transfer from the integrated circuit (IC).

For additional information on the PowerPAD package and how to take advantage of its heat dissipating abilities, refer to Technical Brief, PowerPAD Thermally Enhanced Package, Texas Instruments Literature No. SLMA002 and Application Brief, PowerPAD Made Easy, Texas Instruments Literature No. SLMA004. Both documents are available at www.ti.com.

The exposed thermal pad dimensions for this package are shown in the following illustration.

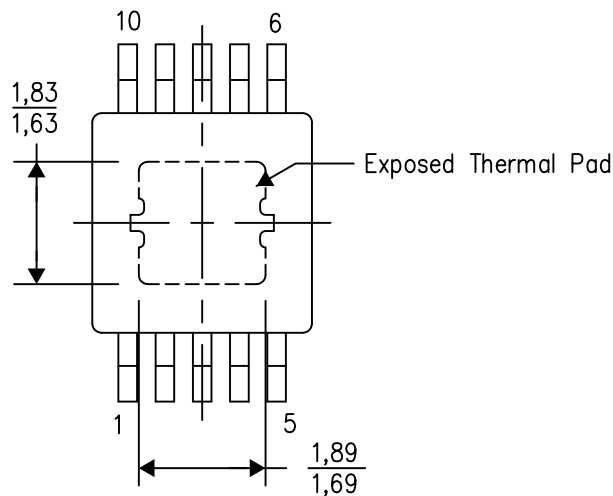

Top View

Exposed Thermal Pad Dimensions

4206324-7/H 12/14

NOTE: A. All linear dimensions are in millimeters

PowerPAD is a trademark of Texas Instruments

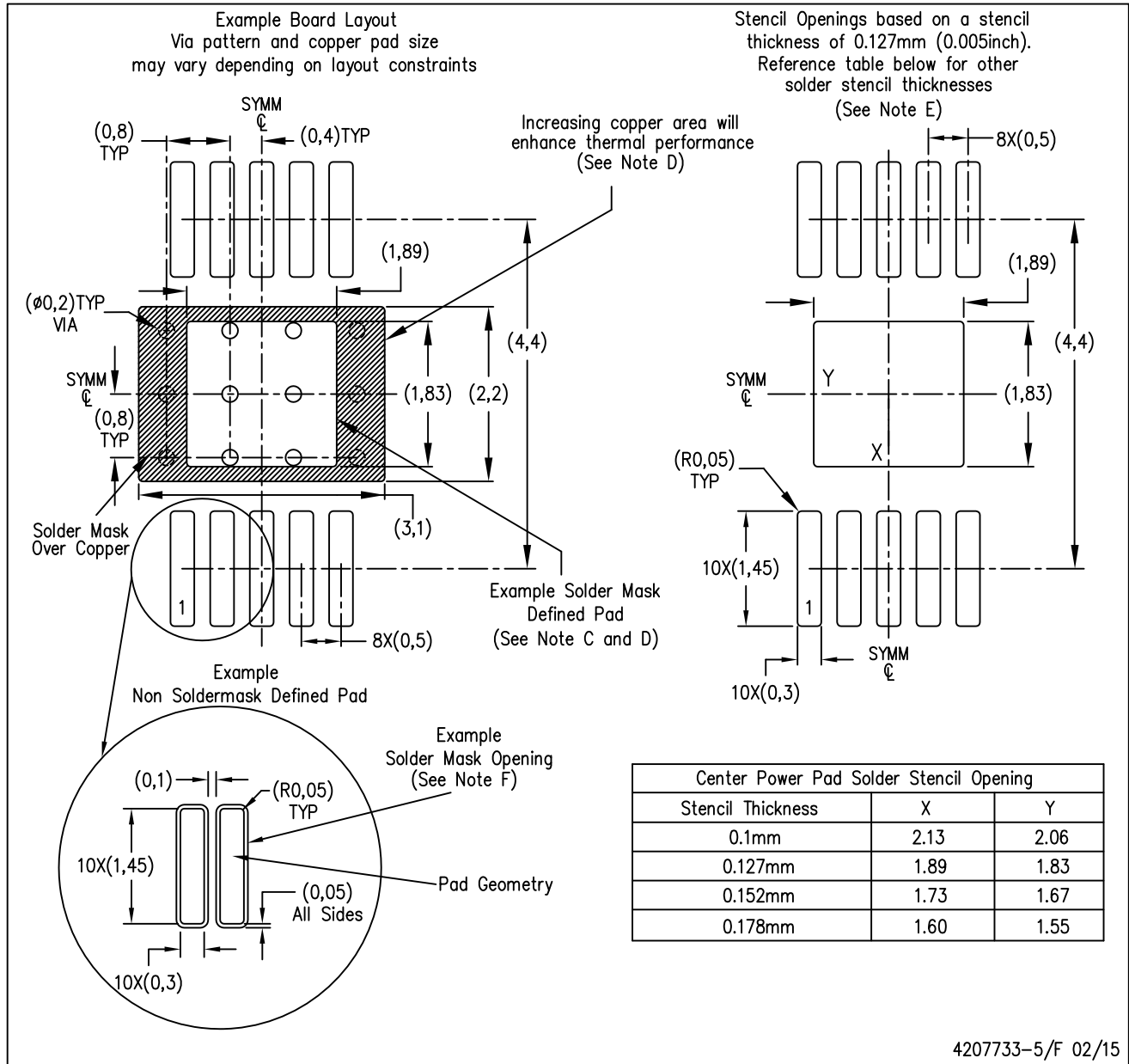

- NOTES:
- A. All linear dimensions are in millimeters.
 - B. This drawing is subject to change without notice.
 - C. Customers should place a note on the circuit board fabrication drawing not to alter the center solder mask defined pad.
 - D. This package is designed to be soldered to a thermal pad on the board. Refer to Technical Brief, PowerPAD Thermally Enhanced Package, Texas Instruments Literature No. SLMA002, SLMA004, and also the Product Data Sheets for specific thermal information, via requirements, and recommended board layout. These documents are available at www.ti.com <<http://www.ti.com>>. Publication IPC-7351 is recommended for alternate designs.
 - E. Laser cutting apertures with trapezoidal walls and also rounding corners will offer better paste release. Customers should contact their board assembly site for stencil design recommendations. Example stencil design based on a 50% volumetric metal load solder paste. Refer to IPC-7525 for other stencil recommendations.
 - F. Customers should contact their board fabrication site for solder mask tolerances between and around signal pads.

PowerPAD is a trademark of Texas Instruments

GENERIC PACKAGE VIEW

DRC 10

VSON - 1 mm max height

PLASTIC SMALL OUTLINE - NO LEAD

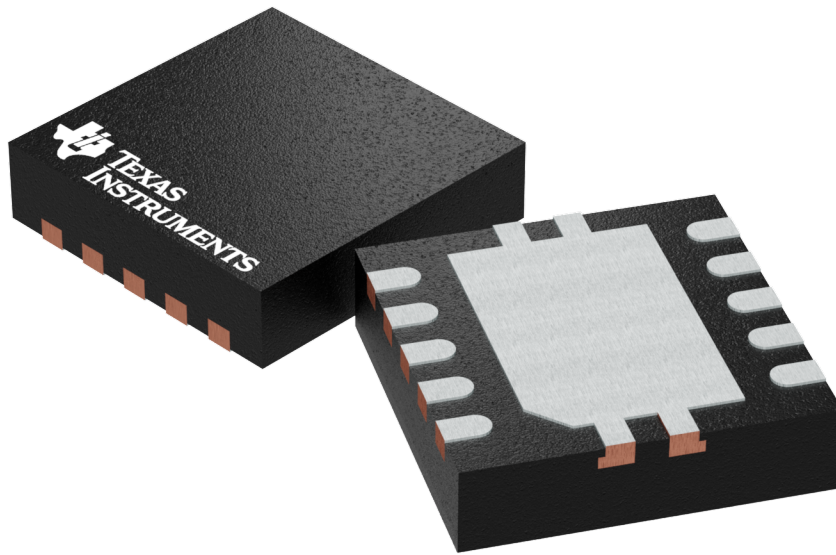

Images above are just a representation of the package family, actual package may vary.
Refer to the product data sheet for package details.

4204102-3/M

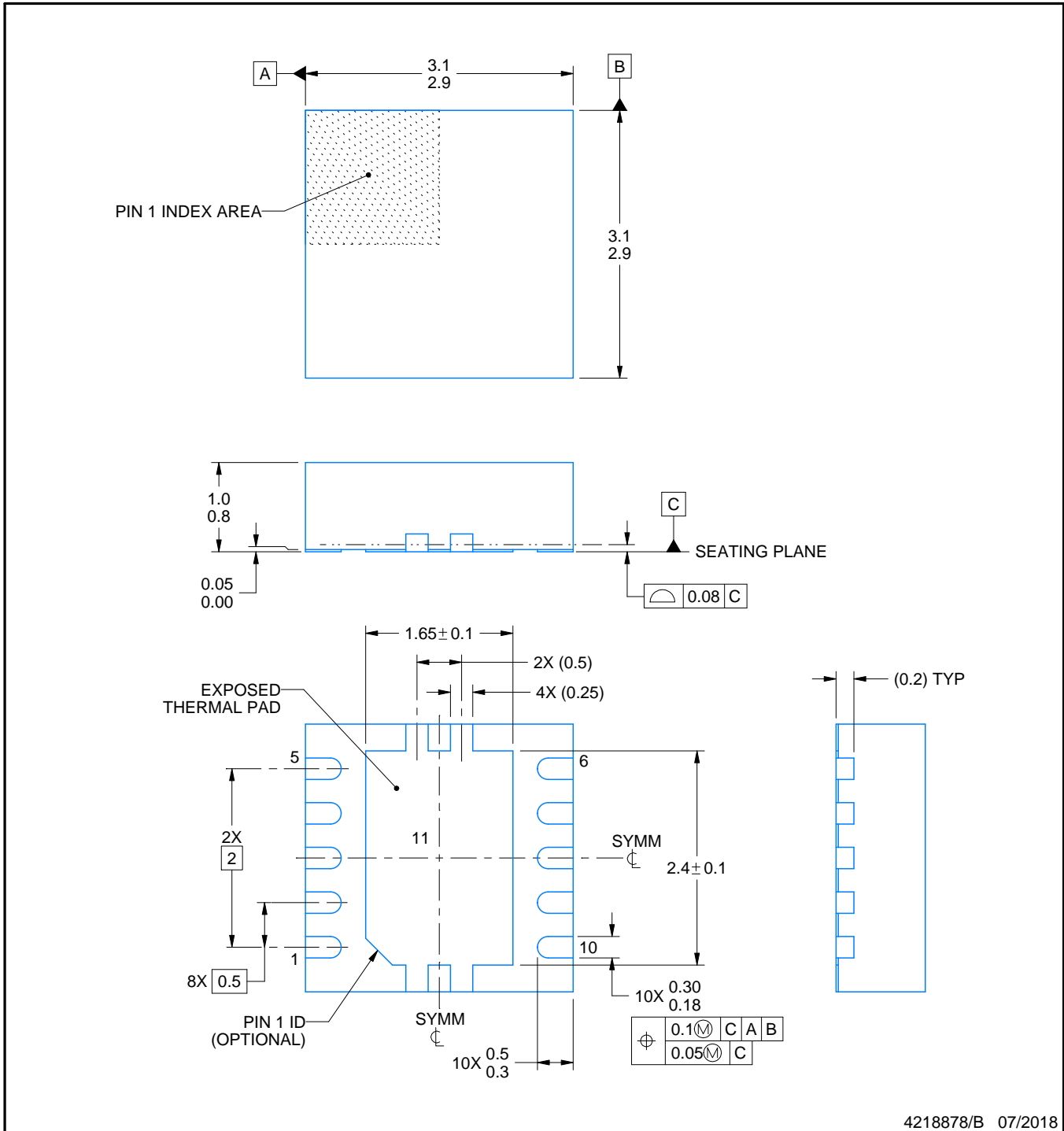

4218878/B 07/2018

NOTES:

1. All linear dimensions are in millimeters. Any dimensions in parenthesis are for reference only. Dimensioning and tolerancing per ASME Y14.5M.
2. This drawing is subject to change without notice.
3. The package thermal pad must be soldered to the printed circuit board for optimal thermal and mechanical performance.

EXAMPLE BOARD LAYOUT

DRC0010J

VSON - 1 mm max height

PLASTIC SMALL OUTLINE - NO LEAD

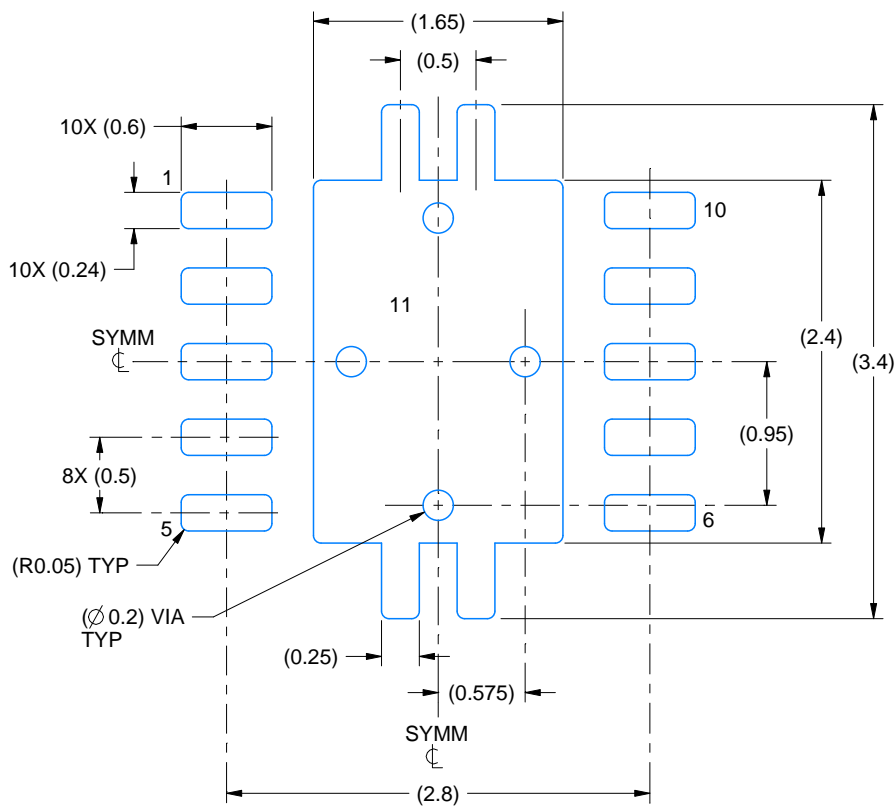

LAND PATTERN EXAMPLE
EXPOSED METAL SHOWN
SCALE:20X

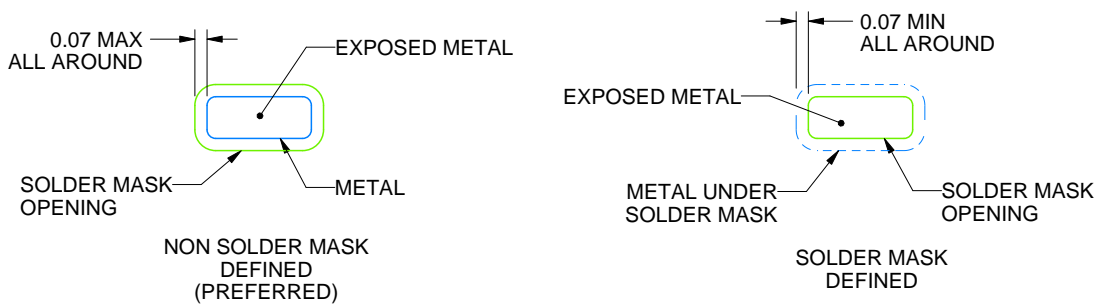

SOLDER MASK DETAILS

4218878/B 07/2018

NOTES: (continued)

4. This package is designed to be soldered to a thermal pad on the board. For more information, see Texas Instruments literature number SLUA271 (www.ti.com/lit/slua271).
5. Vias are optional depending on application, refer to device data sheet. If any vias are implemented, refer to their locations shown on this view. It is recommended that vias under paste be filled, plugged or tented.

EXAMPLE STENCIL DESIGN

DRC0010J

VSON - 1 mm max height

PLASTIC SMALL OUTLINE - NO LEAD

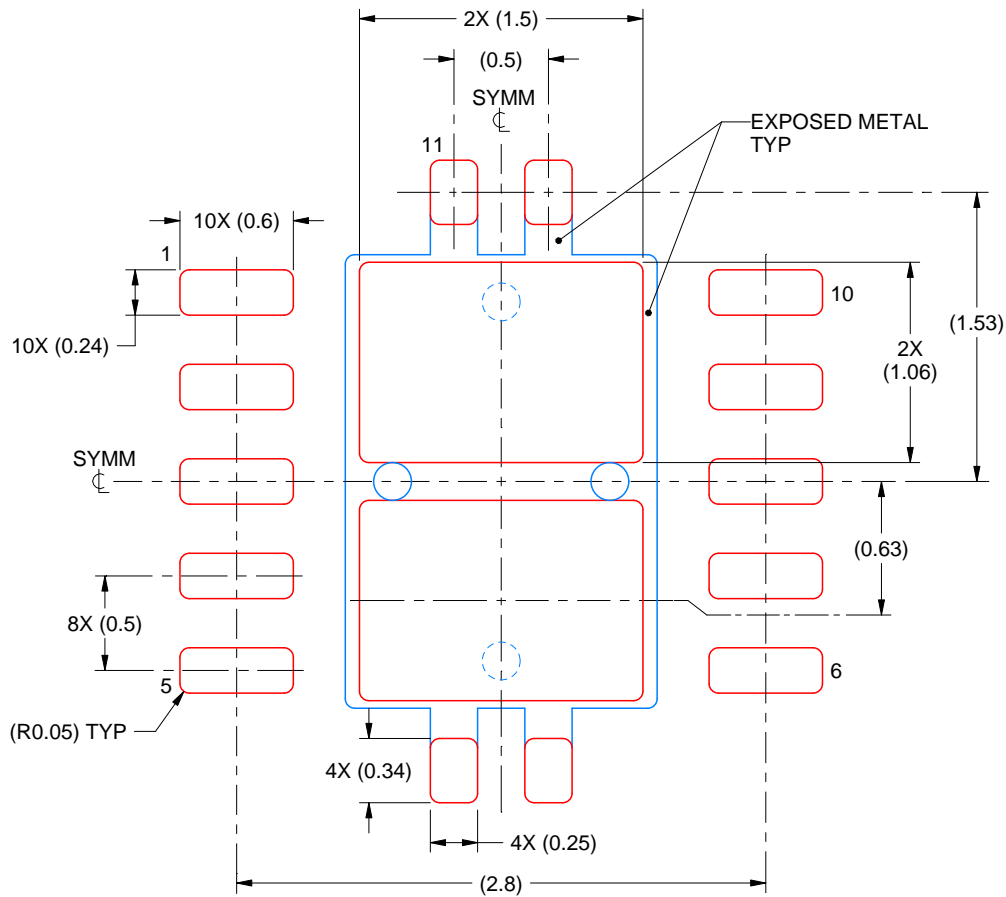

SOLDER PASTE EXAMPLE
BASED ON 0.125 mm THICK STENCIL

EXPOSED PAD 11:
80% PRINTED SOLDER COVERAGE BY AREA
SCALE:25X

4218878/B 07/2018

NOTES: (continued)

6. Laser cutting apertures with trapezoidal walls and rounded corners may offer better paste release. IPC-7525 may have alternate design recommendations.

IMPORTANT NOTICE

Texas Instruments Incorporated (TI) reserves the right to make corrections, enhancements, improvements and other changes to its semiconductor products and services per JESD46, latest issue, and to discontinue any product or service per JESD48, latest issue. Buyers should obtain the latest relevant information before placing orders and should verify that such information is current and complete.

TI's published terms of sale for semiconductor products (<http://www.ti.com/sc/docs/stdterms.htm>) apply to the sale of packaged integrated circuit products that TI has qualified and released to market. Additional terms may apply to the use or sale of other types of TI products and services.

Reproduction of significant portions of TI information in TI data sheets is permissible only if reproduction is without alteration and is accompanied by all associated warranties, conditions, limitations, and notices. TI is not responsible or liable for such reproduced documentation. Information of third parties may be subject to additional restrictions. Resale of TI products or services with statements different from or beyond the parameters stated by TI for that product or service voids all express and any implied warranties for the associated TI product or service and is an unfair and deceptive business practice. TI is not responsible or liable for any such statements.

Buyers and others who are developing systems that incorporate TI products (collectively, "Designers") understand and agree that Designers remain responsible for using their independent analysis, evaluation and judgment in designing their applications and that Designers have full and exclusive responsibility to assure the safety of Designers' applications and compliance of their applications (and of all TI products used in or for Designers' applications) with all applicable regulations, laws and other applicable requirements. Designer represents that, with respect to their applications, Designer has all the necessary expertise to create and implement safeguards that (1) anticipate dangerous consequences of failures, (2) monitor failures and their consequences, and (3) lessen the likelihood of failures that might cause harm and take appropriate actions. Designer agrees that prior to using or distributing any applications that include TI products, Designer will thoroughly test such applications and the functionality of such TI products as used in such applications.

TI's provision of technical, application or other design advice, quality characterization, reliability data or other services or information, including, but not limited to, reference designs and materials relating to evaluation modules, (collectively, "TI Resources") are intended to assist designers who are developing applications that incorporate TI products; by downloading, accessing or using TI Resources in any way, Designer (individually or, if Designer is acting on behalf of a company, Designer's company) agrees to use any particular TI Resource solely for this purpose and subject to the terms of this Notice.

TI's provision of TI Resources does not expand or otherwise alter TI's applicable published warranties or warranty disclaimers for TI products, and no additional obligations or liabilities arise from TI providing such TI Resources. TI reserves the right to make corrections, enhancements, improvements and other changes to its TI Resources. TI has not conducted any testing other than that specifically described in the published documentation for a particular TI Resource.

Designer is authorized to use, copy and modify any individual TI Resource only in connection with the development of applications that include the TI product(s) identified in such TI Resource. NO OTHER LICENSE, EXPRESS OR IMPLIED, BY ESTOPPEL OR OTHERWISE TO ANY OTHER TI INTELLECTUAL PROPERTY RIGHT, AND NO LICENSE TO ANY TECHNOLOGY OR INTELLECTUAL PROPERTY RIGHT OF TI OR ANY THIRD PARTY IS GRANTED HEREIN, including but not limited to any patent right, copyright, mask work right, or other intellectual property right relating to any combination, machine, or process in which TI products or services are used. Information regarding or referencing third-party products or services does not constitute a license to use such products or services, or a warranty or endorsement thereof. Use of TI Resources may require a license from a third party under the patents or other intellectual property of the third party, or a license from TI under the patents or other intellectual property of TI.

TI RESOURCES ARE PROVIDED "AS IS" AND WITH ALL FAULTS. TI DISCLAIMS ALL OTHER WARRANTIES OR REPRESENTATIONS, EXPRESS OR IMPLIED, REGARDING RESOURCES OR USE THEREOF, INCLUDING BUT NOT LIMITED TO ACCURACY OR COMPLETENESS, TITLE, ANY EPIDEMIC FAILURE WARRANTY AND ANY IMPLIED WARRANTIES OF MERCHANTABILITY, FITNESS FOR A PARTICULAR PURPOSE, AND NON-INFRINGEMENT OF ANY THIRD PARTY INTELLECTUAL PROPERTY RIGHTS. TI SHALL NOT BE LIABLE FOR AND SHALL NOT DEFEND OR INDEMNIFY DESIGNER AGAINST ANY CLAIM, INCLUDING BUT NOT LIMITED TO ANY INFRINGEMENT CLAIM THAT RELATES TO OR IS BASED ON ANY COMBINATION OF PRODUCTS EVEN IF DESCRIBED IN TI RESOURCES OR OTHERWISE. IN NO EVENT SHALL TI BE LIABLE FOR ANY ACTUAL, DIRECT, SPECIAL, COLLATERAL, INDIRECT, PUNITIVE, INCIDENTAL, CONSEQUENTIAL OR EXEMPLARY DAMAGES IN CONNECTION WITH OR ARISING OUT OF TI RESOURCES OR USE THEREOF, AND REGARDLESS OF WHETHER TI HAS BEEN ADVISED OF THE POSSIBILITY OF SUCH DAMAGES.

Unless TI has explicitly designated an individual product as meeting the requirements of a particular industry standard (e.g., ISO/TS 16949 and ISO 26262), TI is not responsible for any failure to meet such industry standard requirements.

Where TI specifically promotes products as facilitating functional safety or as compliant with industry functional safety standards, such products are intended to help enable customers to design and create their own applications that meet applicable functional safety standards and requirements. Using products in an application does not by itself establish any safety features in the application. Designers must ensure compliance with safety-related requirements and standards applicable to their applications. Designer may not use any TI products in life-critical medical equipment unless authorized officers of the parties have executed a special contract specifically governing such use. Life-critical medical equipment is medical equipment where failure of such equipment would cause serious bodily injury or death (e.g., life support, pacemakers, defibrillators, heart pumps, neurostimulators, and implantables). Such equipment includes, without limitation, all medical devices identified by the U.S. Food and Drug Administration as Class III devices and equivalent classifications outside the U.S.

TI may expressly designate certain products as completing a particular qualification (e.g., Q100, Military Grade, or Enhanced Product). Designers agree that it has the necessary expertise to select the product with the appropriate qualification designation for their applications and that proper product selection is at Designers' own risk. Designers are solely responsible for compliance with all legal and regulatory requirements in connection with such selection.

Designer will fully indemnify TI and its representatives against any damages, costs, losses, and/or liabilities arising out of Designer's non-compliance with the terms and provisions of this Notice.

Looking for pricing, stock, or lifecycle information?

Click below to explore more details on WIN SOURCE:

 [View TPS54060DGQ](#) on WIN SOURCE

 [Texas Instruments](#) Information

Optimize Your Supply Chain with WIN SOURCE Solutions

-  Global Sourcing Solution
-  Obsolete Management
-  Cost Control Management
-  Shortage Management
-  Alternative Solution
-  Excess Inventory Management