



# THE DATASHEET OF TPS5432DDAR



## 2.95V to 6V Input, 3A Output, 700kHz Synchronous Step Down Converter

Check for Samples: [TPS5432](#)

### FEATURES

- Two 70mΩ (typical) MOSFETs for 3A Continuous Output Current
- Current Mode Control With External Compensation
- 700kHz Switching Frequency
- 360μA no Load Quiescent Operating Current (no switching)
- 0.808V Internal Voltage Reference
- ±2.0% Reference Accuracy at 25°C
- ±3.0% Reference Accuracy Over Temperature Range –40°C~125°C
- Stable Operation With Ceramic Output Capacitor
- Adjustable Slow Start
- Cycle by Cycle Current Limit, and Frequency Fold Back Protection
- Thermally Enhanced 8-Pin SOIC (DDA) Package

### APPLICATIONS

- Consumer Applications such as DTV, Set Top Boxes, LCD displays, CPE
- Low-Voltage Point-of-Load Regulations for SoC, CPU, DSP

### SIMPLIFIED SCHEMATIC

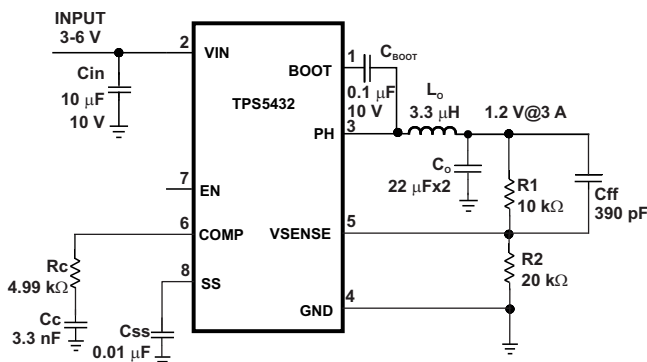

### DESCRIPTION

The TPS5432 is a 6V, 3A, low Iq, current mode, synchronous monolithic buck converter with integrated MOSFETs. The TPS5432 enables small designs by integrating the MOSFETs, implementing current mode control to reduce external component count, reducing inductor size by 700kHz switching frequency. SOIC-8 package with exposed thermal pad provides both thermally enhanced solution and easy to use.

The TPS5432 provides accurate regulation for a variety of loads with an accurate 3.0% voltage reference over temperature.

Efficiency is maximized through the integrated 70mΩ MOSFETs and 360μA typical supply current. Using the enable pin, shutdown supply current is reduced to 2 μA by entering a shutdown mode.

The output voltage startup ramp is controlled by the slow start pin. A ceramic capacitor at this pin can easily adjust the slow start time.

Frequency fold back and thermal shutdown protects the device during an over-current condition.

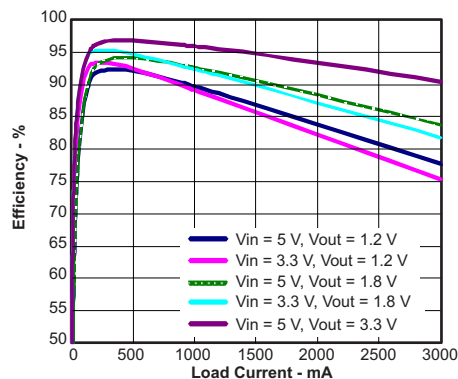

Please be aware that an important notice concerning availability, standard warranty, and use in critical applications of Texas Instruments semiconductor products and disclaimers thereto appears at the end of this data sheet.

PowerPAD is a trademark of Texas Instruments.



These devices have limited built-in ESD protection. The leads should be shorted together or the device placed in conductive foam during storage or handling to prevent electrostatic damage to the MOS gates.

### PIN CONFIGURATION

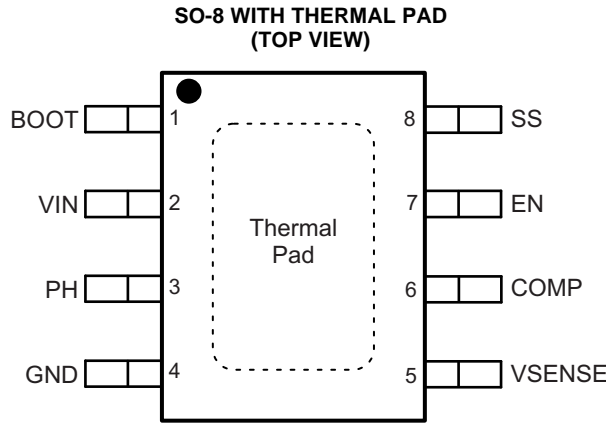

### PIN FUNCTIONS

PIN		DESCRIPTION
NAME	NUMBER	
BOOT	1	A bootstrap cap is required between BOOT and PH. If the voltage on this cap is below the minimum required by the output device, the output is forced to switch off until the cap is refreshed.
COMP	6	Error amplifier output, and input to the output switch current comparator. Connect frequency compensation to this pin.
EN	7	This pin has an internal pull up which enables switching if left open. To disable switching and reduce quiescent current, this pin must be pulled to ground.
GND	4	Ground. This pin should be electrically connected directly to the thermal pad under the IC
PH	3	The source of the internal high side power MOSFET, and drain of the internal low side (synchronous) rectifier MOSFET.
SS	8	Slow start time setting. An external capacitor connected to this pin sets the output rise time
THERMAL PAD	9	GND pin should be connected to the exposed thermal pad for proper operation. This thermal pad should be connected to any internal PCB ground plane using multiple vias for good thermal performance.
VIN	2	Supplies the control circuitry and switches of the power converter. The range is 2.95V to 6V.
VSENSE	5	Inverting node of the gm error amplifier.

### ORDERING INFORMATION<sup>(1)</sup>

T <sub>j</sub>	PACKAGE <sup>(2)</sup> <sup>(3)</sup>		ORDERABLE PART NUMBER
-40°C to 125°C	8-pin SOIC PowerPAD™	Tube	TPS5432DDA
		Tape and Reel	TPS5432DDAR

- (1) For the most current package and ordering information, see the Package Option Addendum at the end of this document, or see the TI web site at [www.ti.com](http://www.ti.com).
- (2) Package drawings, thermal data, and symbolization are available at [www.ti.com/packaging](http://www.ti.com/packaging).
- (3) All package options have Cu NIPDAU lead/ball finish.

**ABSOLUTE MAXIMUM RATING<sup>(1)</sup>**

		VALUE		UNIT
		MIN	MAX	
Input voltage	VIN	-0.3	7	V
	EN	-0.3	3.6	
	BOOT		PH + 7	
	VSENSE	-0.3	3	
	COMP	-0.3	3	
	SS	-0.3	3	
Output voltage	BOOT-PH		7	V
	PH	-0.6	7	
	PH 10 ns Transient	-2	10	
Source current	EN		100	μA
Sink current	COMP		100	μA
	SS		100	
Electrostatic discharge (HBM) QSS 009-105 (JESD22-A114A) <sup>(2)</sup>			2	kV
Electrostatic discharge (CDM) QSS 009-147 (JESD22-C101B.01)			500	V
Temperature	T <sub>J</sub>	-40	150	°C
	T <sub>stg</sub>	-65	150	

- (1) Stresses beyond those listed under absolute maximum ratings may cause permanent damage to the device. These are stress ratings only, and functional operation of the device at these or any other conditions beyond those indicated under ELECTRICAL SPECIFICATIONS is not implied. Exposure to absolute-maximum-rated conditions for extended periods may affect device reliability.
- (2) The human body model is a 100-pF capacitor discharge through a 1.5-kΩ resistor into each pin. The machine model is a 200-pF capacitor discharged directly into each pin.

**THERMAL INFORMATION**

THERMAL METRIC <sup>(1)</sup>		TPS5432	UNITS
		DDA (8 PINS)	
θ <sub>JA</sub>	Junction-to-ambient thermal resistance	42.1	°C/W
θ <sub>JCtop</sub>	Junction-to-case (top) thermal resistance	50.9	
θ <sub>JB</sub>	Junction-to-board thermal resistance	31.8	
ψ <sub>JT</sub>	Junction-to-top characterization parameter	5	
ψ <sub>JB</sub>	Junction-to-board characterization parameter	13.5	
θ <sub>JCbot</sub>	Junction-to-case (bottom) thermal resistance	7.1	

- (1) For more information about traditional and new thermal metrics, see the *IC Package Thermal Metrics* application report, [SPRA953](#).

## ELECTRICAL CHARACTERISTICS

The Electrical Ratings specified in this section apply to all specifications in this document, unless otherwise noted. These specifications are interpreted as conditions that do not degrade the parametric or functional specifications of the device for the life of the product containing it. **Test Conditions:**  $T_J = -40^{\circ}\text{C}$  to  $125^{\circ}\text{C}$ ,  $V_{IN} = 2.95$  to  $6\text{V}$ , (unless otherwise noted)

PARAMETERS	CONDITIONS	MIN	TYP	MAX	UNIT
<b>SUPPLY VOLTAGE</b>					
$V_{in}$		2.95		6	V
$I_q$ shutdown	$EN = 0\text{V}$ , $25^{\circ}\text{C}$ , $2.95\text{V} < V_{in} < 6\text{V}$		2	5	$\mu\text{A}$
$I_q$ operating	No load, $V_{in} = 5\text{V}$ , no switching, $V_{sense} = 1\text{V}$ , $25^{\circ}\text{C}$		360	575	$\mu\text{A}$
<b>VIN UVLO</b>					
Input UVLO threshold	Rising $V_{in}$		2.6	2.8	V
Input UVLO hysteresis			0.2		V
<b>ENABLE</b>					
Enable threshold	Rising	0.984	1.23	1.47	V
Enable threshold	Falling	0.952	1.19		
Input current	Enable threshold +50 mv		-4.6		$\mu\text{A}$
	Enable threshold -50 mv		-1.2		
<b>VOLTAGE REFERENCE</b>					
Reference	$2.95\text{V} < V_{in} < 6\text{V}$ , $T_J = 25^{\circ}\text{C}$	0.792	0.808	0.824	V
	$2.95\text{V} < V_{in} < 6\text{V}$ , $-40^{\circ}\text{C} < T_J < +125^{\circ}\text{C}$	0.784	0.808	0.832	V
<b>MOSFET</b>					
H.S switch resistance	$BOOT-PH = 5\text{V}$ , $T_J = 25^{\circ}\text{C}$		62	86	$\text{m}\Omega$
L.S switch resistance	$V_{in} = 5\text{V}$ , $T_J = 25^{\circ}\text{C}$		73	103	$\text{m}\Omega$
H.S switch resistance	$BOOT-PH = 2.95\text{V}$ , $T_J = 25^{\circ}\text{C}$		88	114	$\text{m}\Omega$
L.S switch resistance	$V_{in} = 2.95\text{V}$ , $T_J = 25^{\circ}\text{C}$		94	128	$\text{m}\Omega$
<b>ERROR AMPLIFIER</b>					
Error amp transconductance (gm)	$-2\mu\text{A} < I_{COMP} < 2\mu\text{A}$ , $V(\text{COMP}) = 1\text{V}$		245		$\mu\text{mho}$
Error amp transconductance (gm) during soft start	$-2\mu\text{A} < I_{COMP} < 2\mu\text{A}$ , $V(\text{COMP}) = 1\text{V}$ , $V_{sense} = 0.3\text{V}$		70		$\mu\text{mho}$
Error amp source/sink	$V(\text{COMP}) = 1\text{V}$ , 100 mV overdrive		$\pm 20$		$\mu\text{A}$
COMP to $I_{ph}$ gm	$V_{in} = 5\text{V}$ , $I_{ph1} = (0.5 \text{ or } 1\text{A})$ and $I_{ph2} = 3\text{A}$		15		A/V
<b>FREQUENCY FOLDBACK vs. VSENSE</b>					
$V_{sense}$ voltage for $F_s$ foldback	50% frequency		0.4		V
$V_{sense}$ voltage for $F_s$ foldback	25% frequency		0.2		V
<b>CURRENT LIMIT</b>					
$I_{max}$ High side FET	$V_{in} = 3.3\text{V}$ , duty cycle = 100%	3.8	5.7	7	A
$I_{max}$ Low side FET		0.8	1.8		A
<b>THERMAL SHUTDOWN</b>					
Thermal Shutdown		155	170		C
OT Hysteresis			15		C
<b>SWITCHING FREQUENCY</b>					
Switching frequency		520	700	880	kHz
<b>PH (PH PIN)</b>					
Minimum on time	$V_{in} = 5\text{V}$ ; Measured at 50% points on PH, $I_{out} = 3\text{A}$		120	150	ns
Minimum off time	Prior to skipping off pulses, $BOOT-PH = 2.95\text{V}$ , $I_{out} = 3\text{A}$		60		ns
Rise/Fall time	$V_{in} = 5\text{V}$ , $I_o = 0\text{A}$		1.5		V/ns
Rise/Fall time	$V_{in} = 5\text{V}$ , $I_o = 3\text{A}$		1.5		V/ns
<b>BOOT</b>					
Boot recharge FET resistance	$V_{in} = 5\text{V}$		15		$\Omega$
Boot UVLO	$V_{in} = 2.95\text{V}$		2.1		V
<b>SLOW START TIME</b>					
Charge current	$V_{ss} = 0.4\text{V}$		2		$\mu\text{A}$

TYPICAL CHARACTERISTICS CURVES

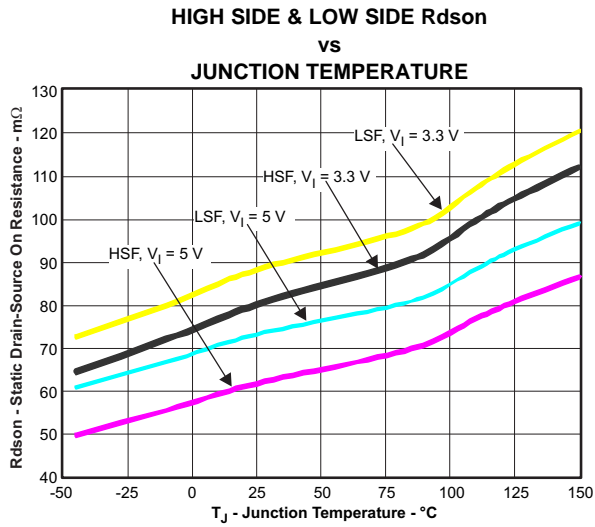

Figure 1.

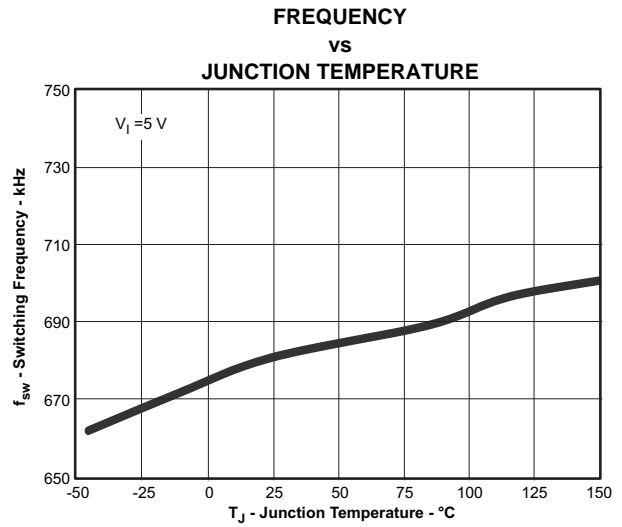

Figure 2.

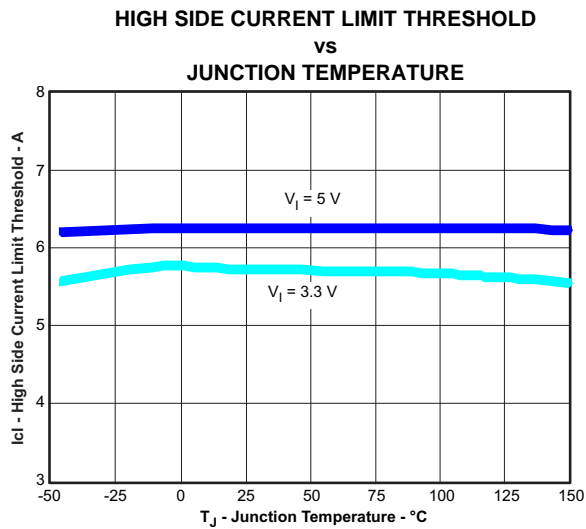

Figure 3.

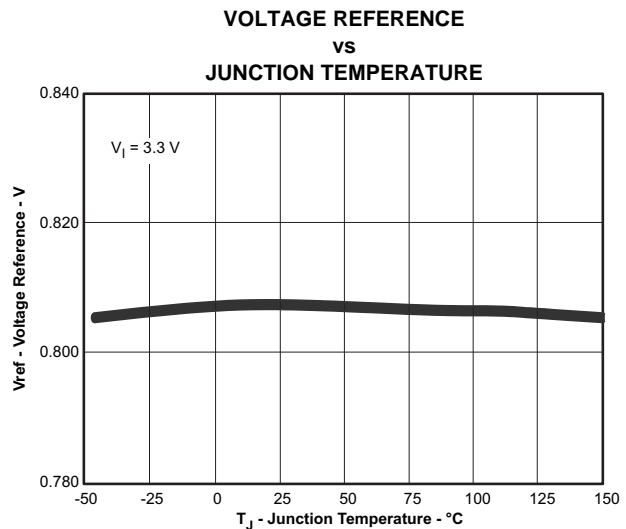

Figure 4.

**TYPICAL CHARACTERISTICS CURVES (continued)**

**SWITCHING FREQUENCY  
vs  
VSENSE**

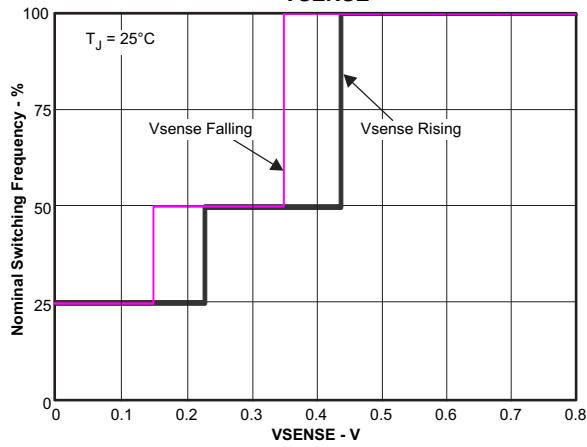

Figure 5.

**EA TRANSCONDUCTANCE  
vs  
JUNCTION TEMPERATURE**

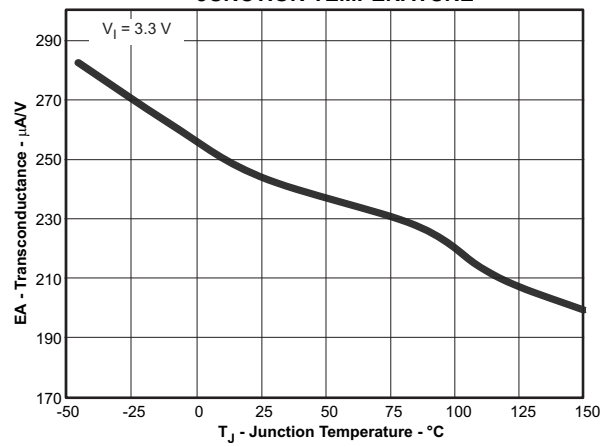

Figure 6.

**EA TRANSCONDUCTANCE (SLOW START)  
vs  
JUNCTION TEMPERATURE**

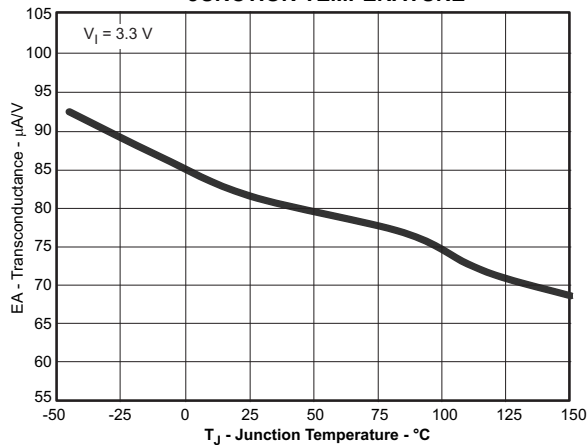

Figure 7.

**SLOW START CHARGE CURRENT  
vs  
JUNCTION TEMPERATURE**

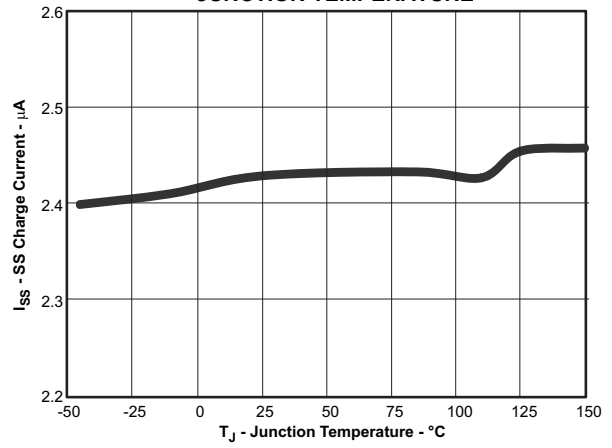

Figure 8.

**TYPICAL CHARACTERISTICS CURVES (continued)**

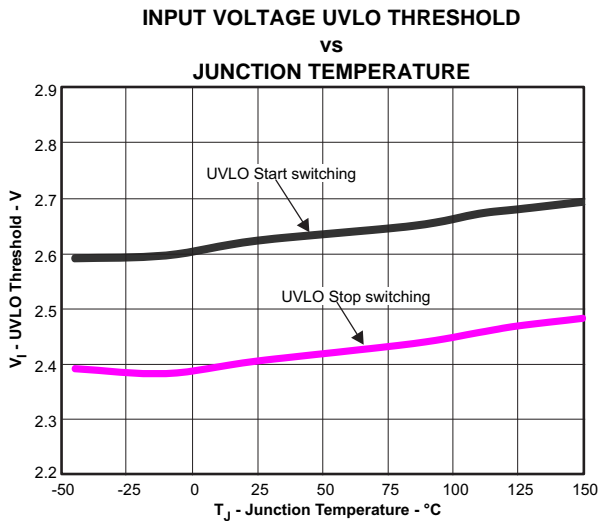

Figure 9.

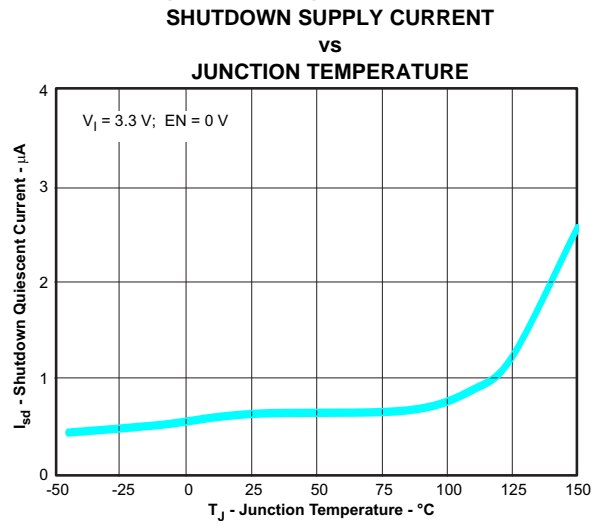

Figure 10.

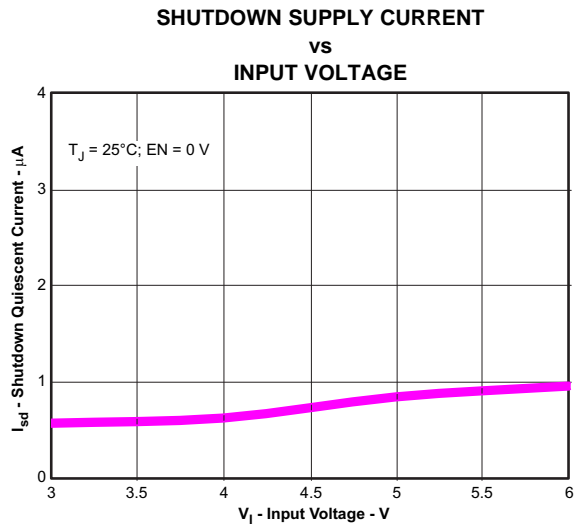

Figure 11.

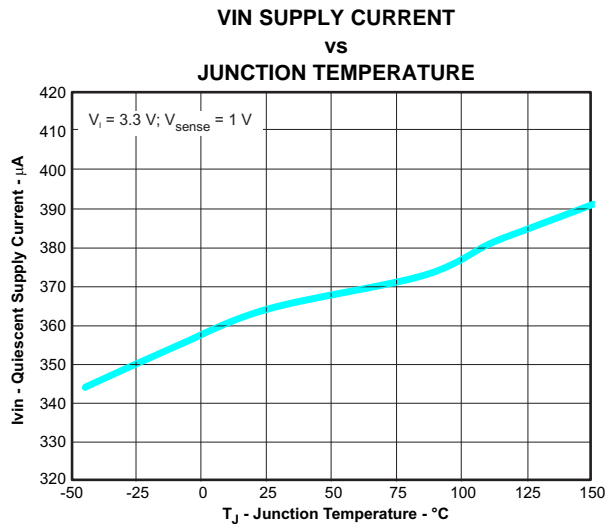

Figure 12.

**TYPICAL CHARACTERISTICS CURVES (continued)**

**VIN SUPPLY CURRENT  
vs  
INPUT VOLTAGE**

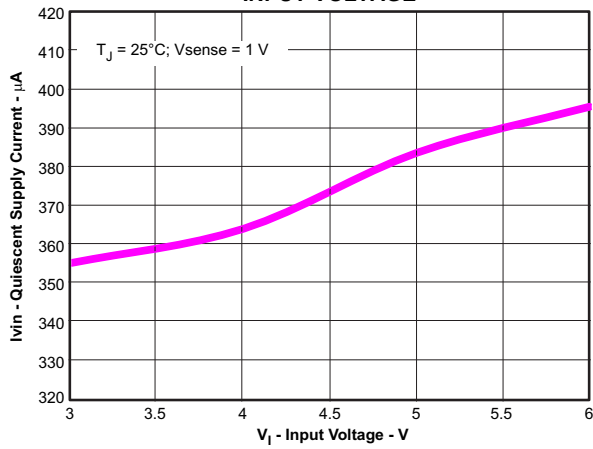

Figure 13.

**EN PIN UVLO THRESHOLD  
vs  
JUNCTION TEMPERATURE**

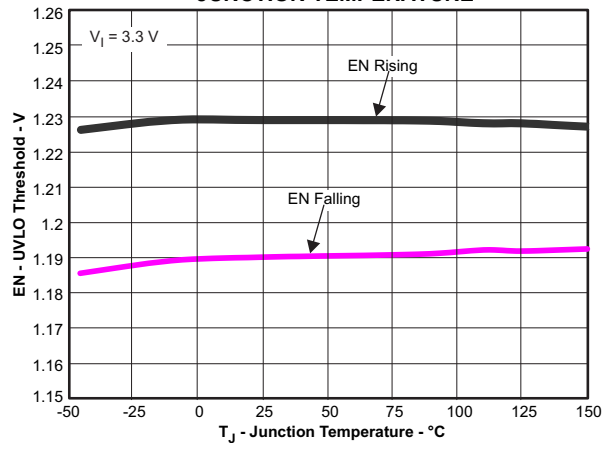

Figure 14.

**EN PIN PULLUP CURRENT  
vs  
JUNCTION TEMPERATURE**

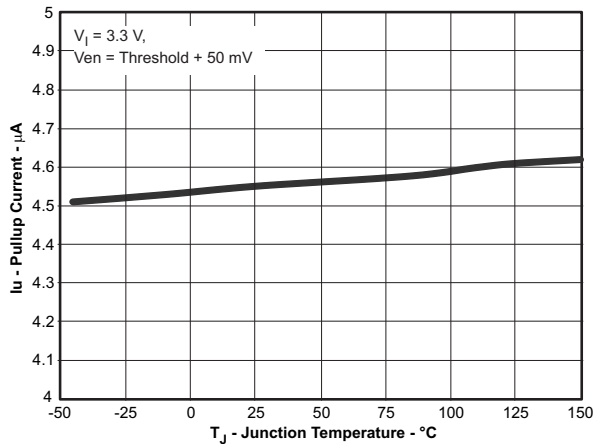

Figure 15.

**EN PIN PULLUP CURRENT  
vs  
JUNCTION TEMPERATURE**

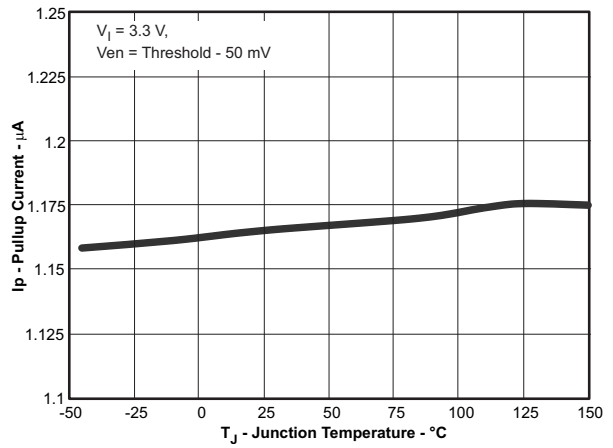
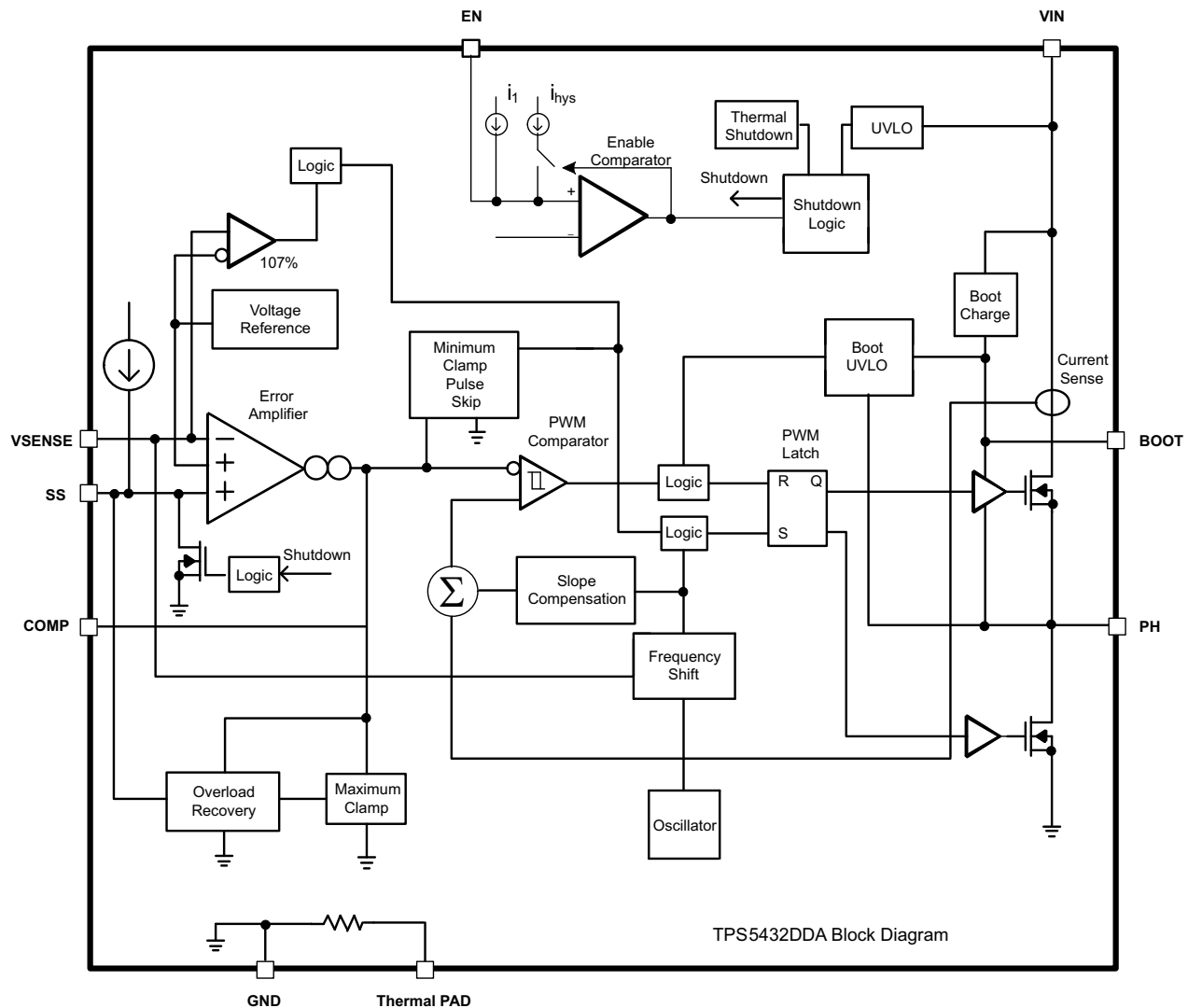

Figure 16.

**SIMPLIFIED BLOCK DIAGRAM (DDA)**



**OVERVIEW**

The TPS5432 is a 6-V, 3-A, synchronous step-down (buck) converter with two integrated n-channel MOSFETs. To improve performance during line and load transients the device implements a constant frequency, peak current mode control which reduces output capacitance and simplifies external frequency compensation design. The fixed switching frequency of 700kHz provides the balance between efficiency and size of the output filter components.

The TPS5432 has a typical default start up voltage of 2.6 V. The EN pin has an internal pull-up current source that can provide a default condition when the EN pin is floating for the device to operate. The total operating current for the TPS5432 is typically 360µA when not switching and under no load. When the device is disabled, the supply current is less than 5µA.

The integrated 70mΩ MOSFETs allow for high efficiency power supply designs with continuous output currents up to 3 amperes.

The TPS5432 reduces the external component count by integrating the boot recharge diode. The bias voltage for the integrated high side MOSFET is supplied by a capacitor between the BOOT and PH pins. The boot capacitor voltage is monitored by an UVLO circuit and turns off the high side MOSFET when the voltage falls below a preset threshold. The output voltage can be stepped down to as low as the 0.808 V reference.

The TPS5432 minimizes excessive output over-voltage transients by taking advantage of the over-voltage comparator. When the regulated output voltage is greater than 107% of the nominal voltage, the over-voltage comparator is activated, and the high side MOSFET is turned off and masked from turning on until the output voltage is lower than 105%.

The SS (slow start) pin is used to minimize inrush currents during power up. A small value capacitor should be coupled to the pin for slow start. The SS pin is discharged before the output power up to ensure a repeatable restart after an over-temperature fault, UVLO fault or disabled condition.

The use of a frequency fold-back circuit reduces the switching frequency during startup and over current fault conditions to help limit the inductor current.

## DETAILED DESCRIPTION

### FIXED FREQUENCY PWM CONTROL

The TPS5432 uses a fixed frequency, peak current mode control. The output voltage is compared through external resistors on the VSENSE pin to an internal voltage reference by an error amplifier which drives the COMP pin. An internal oscillator initiates the turn on of the high side power switch. The error amplifier output is compared to the high side power switch current. When the power switch current reaches the COMP voltage level the high side power switch is turned off and the low side power switch is turned on. The COMP pin voltage increases and decreases as the output current increases and decreases. The device implements a current limit by clamping the COMP pin voltage to a maximum level and also implements a minimum clamp for improved transient response performance.

### SLOPE COMPENSATION AND OUTPUT CURRENT

The TPS5432 adds a compensating ramp to the switch current signal. This slope compensation prevents sub-harmonic oscillations as duty cycle increases. The available peak inductor current remains constant over the full duty cycle range.

### BOOTSTRAP VOLTAGE (BOOT)

The TPS5432 has an integrated boot regulator and requires a small ceramic capacitor between the BOOT and PH pin to provide the gate drive voltage for the high side MOSFET. The value of the ceramic capacitor should be 0.1 $\mu$ F. A ceramic capacitor with an X7R or X5R grade dielectric with a voltage rating of 10 V or higher is recommended because of the stable characteristics over temperature and voltage.

The high side MOSFET is turned off using an UVLO circuit, allowing for the low side MOSFET to conduct when the voltage from BOOT to PH drops below 2.1 V.

The device may work at 100% duty ratio as long as the BOOT-PH voltage is higher than the BOOT-PH UVLO threshold; but, do not operate the device at 100% duty ratio with no load. See additional information regarding 100% duty ratio in the [ENABLE AND UNDERVOLTAGE LOCKOUT](#) section.

### ERROR AMPLIFIER

The TPS5432 has a transconductance amplifier. The error amplifier compares the VSENSE voltage to the lower of the SS pin voltage or the internal 0.808 V voltage reference. The transconductance of the error amplifier is 245 $\mu$ A/V during normal operation. When the voltage of VSENSE pin is below 0.808 V and the device is regulating using the SS voltage, the gm is 70 $\mu$ A/V. The frequency compensation components are placed between the COMP pin and ground.

### VOLTAGE REFERENCE

The voltage reference system produces a precise  $\pm$ 3% voltage reference over temperature by scaling the output of a temperature stable bandgap circuit. The bandgap and scaling circuits produce 0.808 V at the non-inverting input of the error amplifier.

## ADJUSTING THE OUTPUT VOLTAGE

The output voltage is set with a resistor divider from the output node to the VSENSE pin. It is recommended to use divider resistors with 1% tolerance or better. Start with a 10 kΩ for the R1 resistor, [Figure 17](#), and use the [Equation 1](#) to calculate R2. To improve efficiency at light loads consider using larger value resistors. If the values are too high the regulator is more susceptible to noise and voltage errors from the VSENSE input current are noticeable.

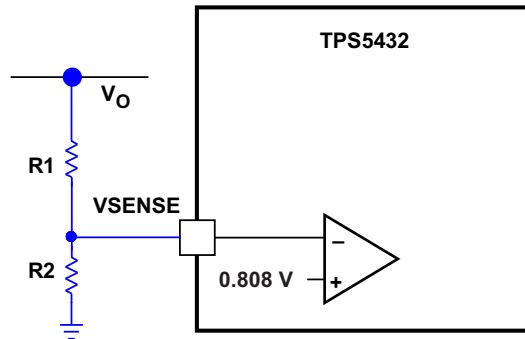

Figure 17. Voltage Divider Circuit

$$R2 = \frac{V_{REF}}{V_{OUT} - V_{REF}} \times R1 \quad (1)$$

## ENABLE AND UNDERVOLTAGE LOCKOUT

The TPS5432 is disabled when the VIN pin voltage falls below 2.4V. If an application requires a higher under-voltage lockout (UVLO), use the EN pin as shown in [Figure 18](#) to adjust the input voltage UVLO by using two external resistors. The EN pin has an internal pull-up current source that provides the default condition of the TPS5432 operating when the EN pin floats. Once the EN pin voltage exceeds 1.23V, an additional 3.4μA of hysteresis is added. When the EN pin is pulled below 1.19V, the 3.4μA is removed. This additional current facilitates input voltage hysteresis.

If the target  $V_{out} > 2.4V$ , it is possible for the IC to work under 100% duty ratio without BOOT-PH voltage > BOOT-PH UVLO threshold satisfied during power up and power down. To avoid this, it is strongly recommended to add a resistor divider (R1 & R2 in [Figure 18](#)) at the EN pin to program VIN UVLO at a new threshold that is higher than  $V_{out}$ .

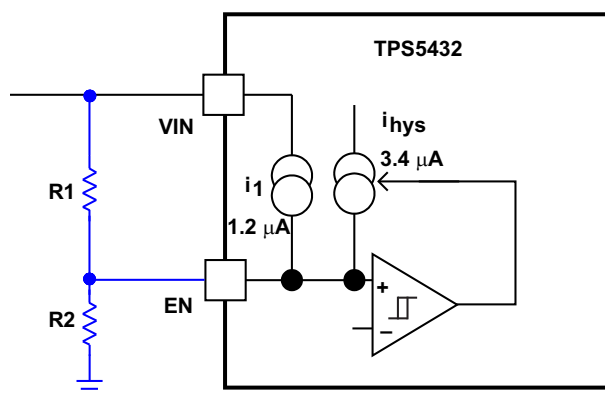

Figure 18. Adjustable Under Voltage Lock Out

$$R1 = \frac{V_{START} \left( \frac{V_{ENFALLING}}{V_{ENRISING}} \right) - V_{STOP}}{I_p \left( 1 - \frac{V_{ENFALLING}}{V_{ENRISING}} \right) + I_h} \quad (2)$$

$$R2 = \frac{R1 \times V_{ENFALLING}}{V_{STOP} - V_{ENFALLING} + R1(I_p + I_h)} \quad (3)$$

Where  $I_h = 3.4 \mu\text{A}$ ,  $I_p = 1.2 \mu\text{A}$ ,  $V_{ENRISING} = 1.23\text{V}$ ,  $V_{ENFALLING} = 1.19\text{V}$   
 $V_{START}$  is the target VIN UVLO rising threshold set by EN resistors.  
 $V_{STOP}$  is the target VIN UVLO falling threshold set by EN resistors.

## SLOW START PIN

The TPS5432 regulates to the lower of the SS pin and the internal reference voltage. A capacitor on the SS pin to ground implements a slow start time. The TPS5432 has an internal pull-up current source of  $2 \mu\text{A}$  which charges the external slow start capacitor. Equation 4 calculates the required slow start capacitor value where TSS is the desired slow start time in ms, ISS is the internal slow start charging current of  $2 \mu\text{A}$ , and Vref is the internal voltage reference of  $0.808\text{V}$ .

If during normal operation, the VIN goes below the UVLO, EN pin pulled below  $1.19\text{V}$ , or a thermal shutdown event occurs, the TPS5432 stops switching and the SS is discharged to  $0\text{V}$  before reinitiating a powering up sequence.

$$C_{ss}(\text{nF}) = \frac{T_{ss}(\text{ms}) \times I_{ss}(\mu\text{A})}{V_{ref}(\text{V})} \quad (4)$$

## OVERCURRENT PROTECTION

The TPS5432 implements a cycle by cycle current limit. During each switching cycle the high side switch current is compared to the voltage on the COMP pin. When the instantaneous switch current intersects the COMP voltage, the high side switch is turned off. During overcurrent conditions that pull the output voltage low, the error amplifier responds by driving the COMP pin high, increasing the switch current. The error amplifier output is clamped internally. This clamp functions as a switch current limit.

## FREQUENCY SHIFT

To operate at high switching frequencies and provide protection during overcurrent conditions, the TPS5432 implements a frequency shift. If frequency shift was not implemented, during an overcurrent condition the low side MOSFET may not be turned off long enough to reduce the current in the inductor, causing a current runaway. With frequency shift, during an overcurrent condition the switching frequency is reduced from 100%, then 50%, then 25% as the voltage decreases from  $0.808\text{V}$  to  $0\text{V}$  on VSENSE pin to allow the low side MOSFET to be off long enough to decrease the current in the inductor. During start-up, the switching frequency increases as the voltage on VSENSE increases from  $0\text{V}$  to  $0.808\text{V}$ . See Figure 5 for details.

## REVERSE OVERCURRENT PROTECTION

The TPS5432 implements low side current protection by detecting the voltage across the low side MOSFET. When the converter sinks current through its low side FET, the control circuit turns off the low side MOSFET if the reverse current is more than  $1.8\text{A}$ . By implementing this additional protection scheme, the converter is able to protect itself from excessive current during power cycling and start-up into pre-biased outputs.

## OVERVOLTAGE TRANSIENT PROTECTION

The TPS5432 incorporates an overvoltage transient protection (OVTP) circuit to minimize voltage overshoot when recovering from output fault conditions or strong unload transients. The OVTP feature minimizes the output overshoot by implementing a circuit to compare the VSENSE pin voltage to the OVTP threshold which is 107% of the internal voltage reference. If the VSENSE pin voltage is greater than the OVTP threshold, the high side MOSFET is disabled preventing current from flowing to the output and minimizing output overshoot. When the VSENSE voltage drops lower than the OVTP threshold, which is 105% of the internal voltage reference, the high side MOSFET is allowed to turn on the next clock cycle.

## THERMAL SHUTDOWN

The device implements an internal thermal shutdown to protect itself if the junction temperature exceeds 170°C. The thermal shutdown forces the device to stop switching when the junction temperature exceeds the thermal trip threshold. Once the die temperature decreases below 155°C, the device reinitiates the power-up sequence by discharging the SS pin to 0 volts. The thermal shutdown hysteresis is 15°C.

## APPLICATION INFORMATION

### DESIGN GUIDE – STEP-BY-STEP DESIGN PROCEDURE

This example details the design of a high frequency switching regulator design using ceramic output capacitors. This design is available as the TPS5432EVM-116 (PWR116) evaluation module (EVM). A few parameters must be known in order to start the design process. These parameters are typically determined on the system level. For this example, we start with the following known parameters:

Output Voltage	1.8 V
Transient Response 0.75 A to 2.25 A load step (25% to 75% maximum load)	$\Delta V_{out} = 6\%$
Maximum Output Current	3 A
Input Voltage	3 V to 6V, 5 V nominal
Output Voltage Ripple	< 18 mV p-p
Switching Frequency (F <sub>sw</sub> )	700 kHz

The schematic diagram for this design example is shown in [Figure 19](#). The component reference designators of this schematic are used for the equations in [APPLICATION INFORMATION](#).

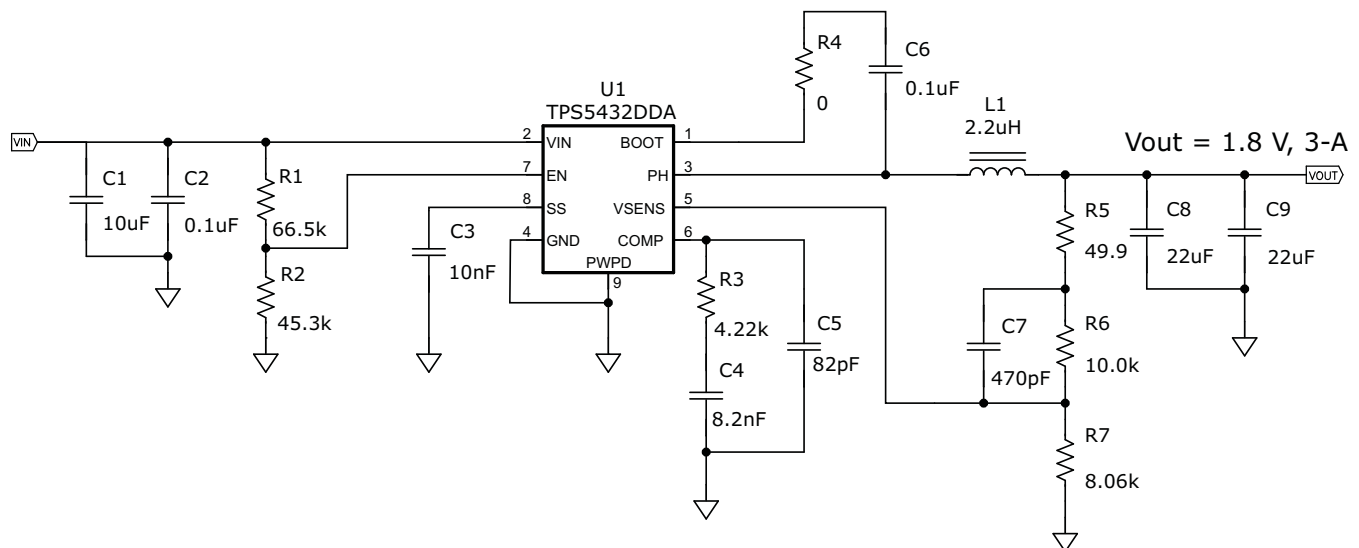

**Figure 19. 1.8 V Output Power Supply Design with Adjustable UVLO**

### OUTPUT INDUCTOR SELECTION

The inductor selected works for the entire TPS5432 input voltage range. To calculate the value of the output inductor, use [Equation 5](#).  $K_{IND}$  is a coefficient that represents the amount of inductor ripple current relative to the maximum output current. The inductor ripple current is filtered by the output capacitor. Therefore, choosing high inductor ripple currents impacts the selection of the output capacitor since the output capacitor must have a ripple current rating equal to or greater than the inductor ripple current. In general, the inductor ripple value is at the discretion of the designer; however,  $K_{IND}$  is normally from 0.1 to 0.3 for the majority of applications.

For this design example, use  $K_{IND} = 0.3$  and the minimum inductor value is calculated to be 2.0  $\mu\text{H}$ . For this design, a nearest standard value was chosen: 2.2  $\mu\text{H}$ . For the output filter inductor, it is important that the RMS current and saturation current ratings not be exceeded. The RMS and peak inductor current can be found from [Equation 7](#) and [Equation 8](#).

For this design, the RMS inductor current is 3.009 A and the peak inductor current is 3.409 A. The chosen inductor is a TDK SPM6530T-2R2M. It has a saturation current rating of 8.4 A (20% inductance loss) and a RMS current rating of 8.2 A (40 °C. temperature rise). The series resistance is 17.3 m $\Omega$  typical.

The current flowing through the inductor is the inductor ripple current plus the output current. During power up, faults or transient load conditions, the inductor current can increase above the calculated peak inductor current level calculated above. In transient conditions, the inductor current can increase up to the switch current limit of the device. For this reason, the most conservative approach is to specify an inductor with a saturation current rating equal to or greater than the switch current limit rather than the peak inductor current.

$$L1 = \frac{V_{inmax} - V_{out}}{I_o \times K_{ind}} \times \frac{V_{out}}{V_{inmax} \times f_{sw}} \quad (5)$$

$$I_{ripple} = \frac{V_{inmax} - V_{out}}{L1} \times \frac{V_{out}}{V_{inmax} \times f_{sw}} \quad (6)$$

$$I_{Lrms} = \sqrt{I_o^2 + \frac{1}{12} \times \left( \frac{V_o \times (V_{inmax} - V_o)}{V_{inmax} \times L1 \times f_{sw}} \right)^2} \quad (7)$$

$$I_{Lpeak} = I_{out} + \frac{I_{ripple}}{2} \quad (8)$$

## OUTPUT CAPACITOR

There are three primary considerations for selecting the value of the output capacitor. The output capacitor determines the modulator pole, the output voltage ripple, and how the regulator responds to a large change in load current. The output capacitance needs to be selected based on the more stringent of these three criteria.

The desired response to a large change in the load current is the first criteria. The output capacitor needs to supply the load with current when the regulator can not. This situation would occur if there are desired hold-up times for the regulator where the output capacitor must hold the output voltage above a certain level for a specified amount of time after the input power is removed. The regulator is temporarily not able to supply sufficient output current if there is a large, fast increase in the current needs of the load such as a transition from no load to full load. The regulator usually needs two or more clock cycles for the control loop to see the change in load current and output voltage and adjust the duty cycle to react to the change. The output capacitor must be sized to supply the extra current to the load until the control loop responds to the load change. The output capacitance must be large enough to supply the difference in current for 2 clock cycles while only allowing a tolerable amount of drop in the output voltage. [Equation 9](#) shows the minimum output capacitance necessary to accomplish this.

For this example, the transient load response is specified as a 6% change in  $V_{out}$  for a load step from 0.75 A (25% load) to 2.25 A (75% load). For this example,  $\Delta I_{out} = 2.25 \text{ A} - 0.75 \text{ A} = 1.5 \text{ A}$  and  $\Delta V_{out} = 0.06 \times 1.8 = 0.108 \text{ V}$ . Using these numbers gives a minimum capacitance of 39.7  $\mu\text{F}$ . This value does not take the ESR of the output capacitor into account in the output voltage change. For ceramic capacitors, the ESR is usually small enough to ignore in this calculation.

**Equation 10** calculates the minimum output capacitance needed to meet the output voltage ripple specification. Where  $f_{sw}$  is the switching frequency,  $V_{ripple}$  is the maximum allowable output voltage ripple, and  $I_{ripple}$  is the inductor ripple current. In this case, the maximum output voltage ripple is 18 mV. Under this requirement, **Equation 10** yields 8.1  $\mu\text{F}$ .

$$C_o > \frac{2 \times \Delta I_{out}}{f_{sw} \times \Delta V_{out}} \quad (9)$$

$$C_o > \frac{1}{8 \times f_{sw}} \times \frac{1}{\frac{V_{ripple}}{I_{ripple}}}$$

Where  $\Delta I_{out}$  is the change in output current,  $f_{sw}$  is the regulators switching frequency and  $\Delta V_{out}$  is the allowable change in the output voltage. (10)

**Equation 11** calculates the maximum ESR an output capacitor can have to meet the output voltage ripple specification. **Equation 11** indicates the ESR should be less than 22 m $\Omega$ . In this case, the ESR of the ceramic capacitor is much less than 22 m $\Omega$ .

Additional capacitance de-ratings for aging, temperature and DC bias should be factored in which increases this minimum value. For this example, two 22  $\mu\text{F}$  10 V X5R ceramic capacitors with 3 m $\Omega$  of ESR are used. The estimated capacitance after derating is  $2 \times 22 \mu\text{F} = 44 \mu\text{F}$ .

Capacitors generally have limits to the amount of ripple current they can handle without failing or producing excess heat. An output capacitor that can support the inductor ripple current must be specified. Some capacitor data sheets specify the RMS (Root Mean Square) value of the maximum ripple current. **Equation 12** can be used to calculate the RMS ripple current the output capacitor needs to support. For this application, **Equation 12** yields 236 mA.

$$Resr < \frac{V_{ripple}}{I_{ripple}} \quad (11)$$

$$I_{corms} = \frac{V_{out} \times (V_{inmax} - V_{out})}{\sqrt{12} \times V_{inmax} \times L1 \times f_{sw}} \quad (12)$$

## INPUT CAPACITOR

The TPS5432 requires a high quality ceramic, type X5R or X7R, input decoupling capacitor of at least 10  $\mu\text{F}$  of effective capacitance and in some applications a bulk capacitance. The effective capacitance includes any DC bias effects. The voltage rating of the input capacitor must be greater than the maximum input voltage. The capacitor must also have a ripple current rating greater than the maximum input current ripple of the TPS5432. The input ripple current can be calculated using **Equation 13**.

The value of a ceramic capacitor varies significantly over temperature and the amount of DC bias applied to the capacitor. The capacitance variations due to temperature can be minimized by selecting a dielectric material that is stable over temperature. X5R and X7R ceramic dielectrics are usually selected for power regulator capacitors because they have a high capacitance to volume ratio and are fairly stable over temperature. The output capacitor must also be selected with the DC bias taken into account. The capacitance value of a capacitor decreases as the DC bias across a capacitor increases.

For this example design, a ceramic capacitor with at least a 10 V voltage rating is required to support the maximum input voltage. For this example, one 10  $\mu\text{F}$  and one 0.1  $\mu\text{F}$  10 V capacitors in parallel have been selected. The input capacitance value determines the input ripple voltage of the regulator. The input voltage ripple can be calculated using **Equation 14**. Using the design example values,  $I_{outmax} = 3 \text{ A}$ ,  $C_{in} = 10 \mu\text{F}$ ,  $F_{sw} = 700 \text{ kHz}$ , yields an input voltage ripple of 106 mV and a rms input ripple current of 1.47 A.

$$I_{cirms} = I_{out} \times \sqrt{\frac{V_{out}}{V_{inmin}} \times \frac{(V_{inmin} - V_{out})}{V_{inmin}}} \quad (13)$$

$$\Delta V_{in} = \frac{I_{outmax} \times 0.25}{C_{in} \times f_{sw}} \quad (14)$$

## SLOW START CAPACITOR

The slow start capacitor determines the minimum amount of time it takes for the output voltage to reach its nominal programmed value during power up. This is useful if a load requires a controlled voltage slew rate. This is also used if the output capacitance is very large and would require large amounts of current to quickly charge the capacitor to the output voltage level. The large currents necessary to charge the capacitor may make the TPS5432 reach the current limit or excessive current draw from the input power supply may cause the input voltage rail to sag. Limiting the output voltage slew rate solves both of these problems.

The slow start capacitor value can be calculated using [Equation 15](#). For the example circuit, the slow start time is not too critical since the output capacitor value is 2 x 22 μF which does not require much current to charge to 1.8 V. The example circuit has the slow start time set to an arbitrary value of 3.33 ms which requires a 10 nF capacitor.

$$C3(nF) = 3 \cdot T_{ss}(mS) \quad (15)$$

## OUTPUT VOLTAGE AND FEEDBACK RESISTORS SELECTION

For the example design, 10.0 kΩ was selected for R6. Using [Equation 16](#), R7 is calculated as 8.15 kΩ. A close standard 1% resistor is 8.06 kΩ.

$$R7 = \frac{R6 \cdot V_{REF}}{V_{OUT} - V_{REF}} \quad (16)$$

The TPS5432 can regulate to output voltages at or above the internal voltage reference of 0.808 V. Theoretically, the output voltage may be limited by the minimum controllable on time of the device. For the TPS5432, this should never be an issue as the minimum output voltage of 0.808 V, maximum input voltage of 6 V and the fixed operating frequency of 700 kHz will always result in on times above the minimum.

There is also a maximum achievable output voltage which is limited by the minimum off time of 60 nsec typical. For normal operation, that limits the effective duty cycle to 95.8%. The TPS5432 can operate at higher effective duty cycles. In this operating mode, the device will have some switching cycles where the on time is 100% of the cycle. If the output current is increased further at this point, two discreet operating mode will occur sequentially. In the first mode, the device will switch at the normal 700 kHz frequency with the off time at the minimum (60 nsec typical). in the second mode the every alternating switching cycle will be at 100 % on time followed by a cycle with an off time greater than the minimum. The apparent effect is reduction of the operating frequency by 50%. The long term average duty cycle is greater than 95.8%, allowing the device to regulate with input voltages that approach the output voltage.

## COMPENSATION

There are several possible methods to design closed loop compensation for dc/dc converters. For the ideal current mode control, the design equations can be easily simplified. The power stage gain is constant at low frequencies, and rolls off at -20 dB/decade above the modulator pole frequency. The power stage phase is 0 degrees at low frequencies and starts to fall one decade below the modulator pole frequency reaching a minimum of -90 degrees one decade above the modulator pole frequency. The modulator pole is a simple pole shown in [Equation 17](#).

$$F_{PMOD} = \frac{1}{2 \cdot \pi \cdot C_{OUT} \cdot R_{OUT}} \quad (17)$$

For the TPS5432 most circuits will have relatively high amounts of slope compensation. As more slope compensation is applied, the power stage characteristics will deviate from the ideal approximations. The phase loss of the power stage will now approach -180 degrees, making compensation more difficult. The power stage transfer function can be solved but it is a tedious hand calculation that does not lend itself to simple approximations. It is best to use Pspice or TINA-TI to accurately model the power stage gain and phase so that a reliable compensation circuit can be designed. That is the technique used in this design procedure. Using the pspice model of [SLVM279](#) apply the values calculated previously to the output filter components of L1, C9 and C10. Set Rload to the appropriate value. For this design, L1 = 2.2 μH. C8 and C9 use the derated capacitance value of 22 μF, and the ESR is set to 3 mΩ. The Rload resistor is 1.8 / 1.5 = 1.2 Ω. Now the power stage characteristic can be plotted as shown in [Figure 20](#).

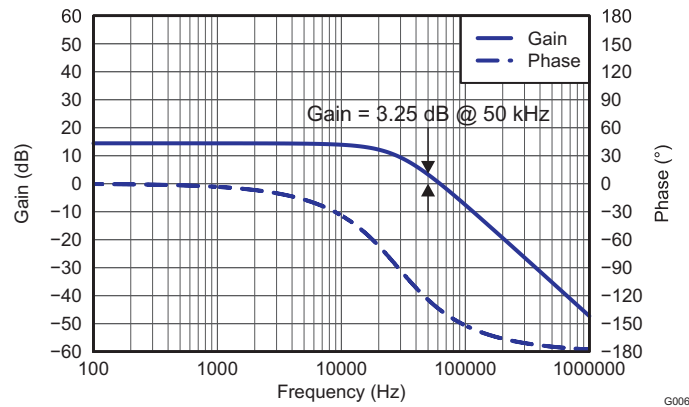

**Figure 20. Power Stage Gain and Phase Characteristics**

For this design, the intended crossover frequency is 50 kHz. From the power stage gain and phase plots, the gain at 50 kHz is 3.25 dB and the phase is -128 degrees. For 60 degrees of phase margin, additional phase boost from a feed forward capacitor in parallel with the upper resistor of the voltage set point divider will be required. R3 sets the gain of the compensated error amplifier to be equal and opposite the power stage gain at crossover. The required value of R3 can be calculated from [Equation 18](#).

$$R3 = \frac{10^{\frac{-G_{PWRSTG}}{20}}}{g_{mEA}} \cdot \sqrt{\frac{V_{out}}{V_{REF}}} \quad (18)$$

To maximize phase gain, the compensator zero  $F_z$  is placed one decade below the crossover frequency  $F_{CO}$  of 50 kHz. The required value for C4 is given by [Equation 19](#).

$$C4 = \frac{1}{2 \cdot \pi \cdot R3 \cdot \frac{F_{CO}}{10}} \quad (19)$$

To maximize phase gain the high frequency pole  $F_p$  is placed one decade above the crossover frequency  $F_{CO}$ . The pole can also be useful to offset the ESR of aluminum electrolytic output capacitors. The value for C5 can be calculated from [Equation 20](#).

$$C5 = \frac{1}{2 \cdot \pi \cdot R3 \cdot F_p} \quad (20)$$

The feed forward capacitor C7, is used to increase the phase boost at crossover above what is normally available from Type II compensation. It places an additional zero/pole pair located at [Equation 21](#) and [Equation 22](#).

$$F_z = \frac{1}{2 \cdot \pi \cdot C7 \cdot R6} \quad (21)$$

$$F_p = \frac{1}{2 \cdot \pi \cdot C7 \cdot R6 \parallel R7} \quad (22)$$

This zero and pole pair is not independent. Once the zero location is chosen, the pole is fixed as well. For optimum performance, the zero and pole should be located symmetrically about the intended crossover frequency. The required value for C10 can be calculated from Equation 23.

$$C7 = \frac{1}{2 \cdot \pi \cdot R6 \cdot F_{CO} \cdot \sqrt{\frac{V_{REF}}{V_{OUT}}}} \tag{23}$$

For this design the calculated values for the compensation components are R3 = 4.19 kΩ , C4 = 7596 pF, C5 = 76 pF and C7 = 475 pF. Using standard values, the compensation components are R3 = 4.22 kΩ , C4 = 8200 pF, C5 = 82 pF and C7 = 470 pF.

**APPLICATION CURVES**

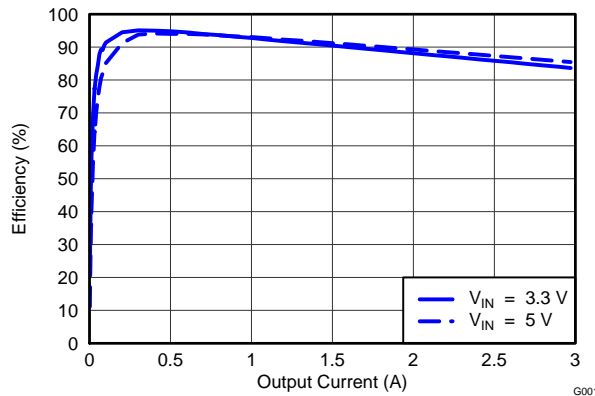

**Figure 21. EFFICIENCY vs LOAD CURRENT**

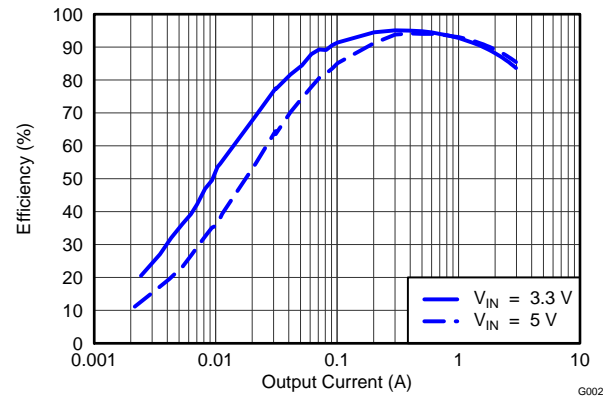

**Figure 22. EFFICIENCY vs LOAD CURRENT**

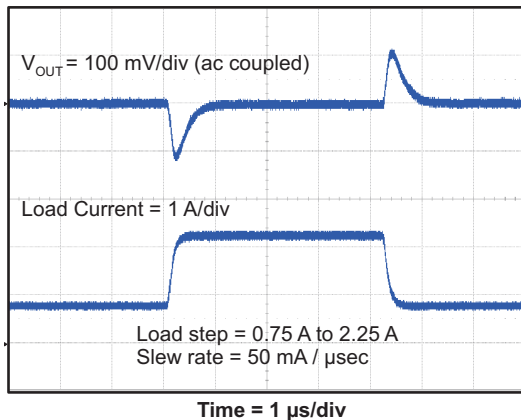

**Figure 23. TRANSIENT RESPONSE, 1.5 A STEP**

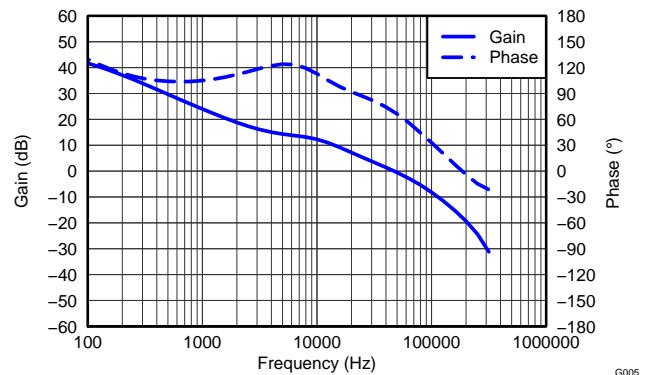

**Figure 24. CLOSED LOOP RESPONSE, VIN = 5 V, IOUT = 1.5 A**

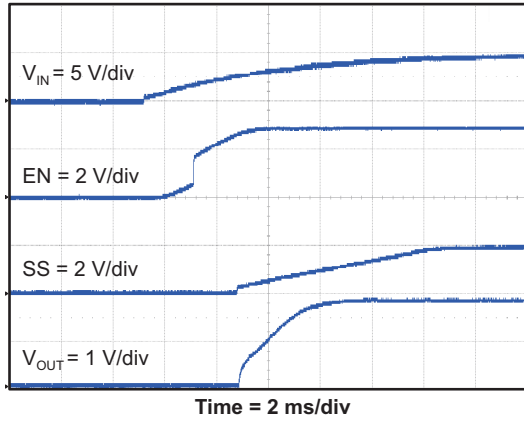

Figure 25. START UP RELATIVE TO  $V_{IN}$

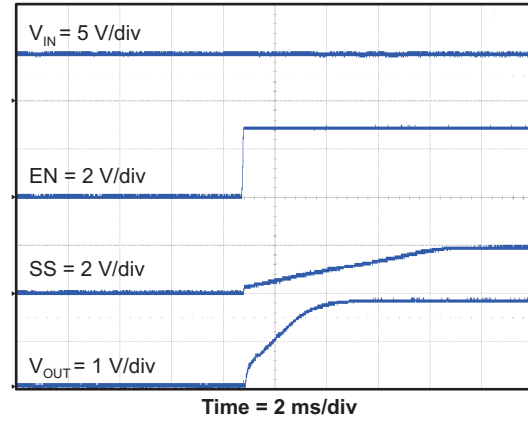

Figure 26. START UP RELATIVE TO EN

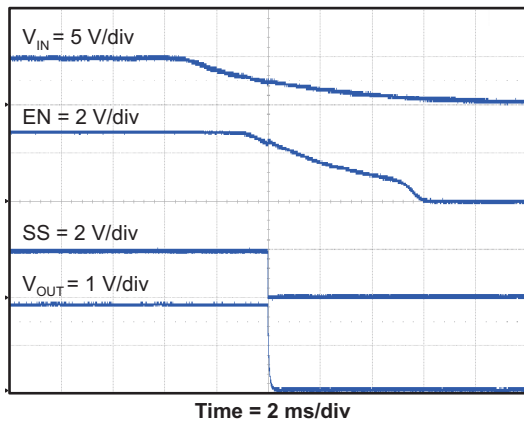

Figure 27. SHUT DOWN RELATIVE TO  $V_{IN}$

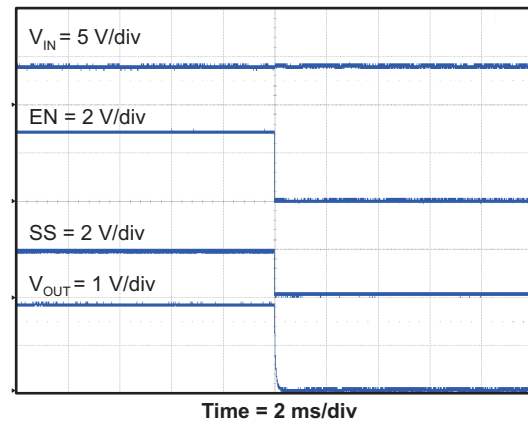

Figure 28. SHUT DOWN RELATIVE TO EN

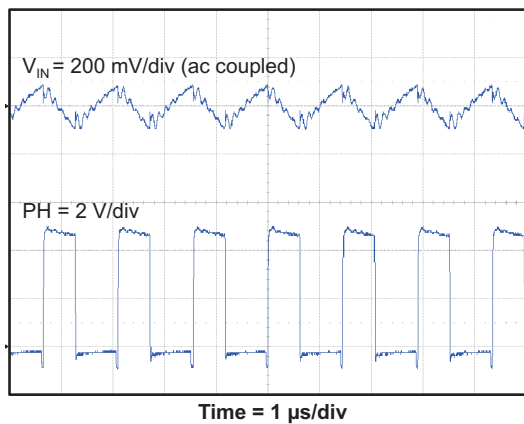

Figure 29. INPUT VOLTAGE RIPPLE,  $I_{OUT} = 3\text{ A}$

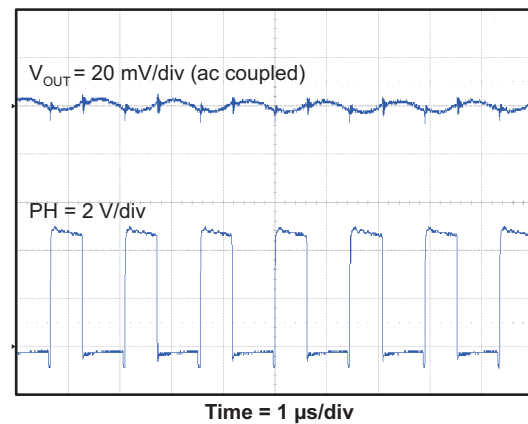

Figure 30. OUTPUT VOLTAGE RIPPLE,  $I_{OUT} = 3\text{ A}$

## LAYOUT

Layout is a critical portion of good power supply design. There are several signal paths that conduct fast changing currents or voltages that can interact with stray inductance or parasitic capacitance to generate noise or degrade the power supplies performance. Care should be taken to minimize the loop area formed by the bypass capacitor connections and the VIN pins. See [Figure 31](#) for a PCB layout example. The GND pin should be tied directly to the power pad under the IC. The analog ground trace should be connected to the power ground area at a single point. The power pad should be connected to any internal PCB ground planes using multiple vias directly under the IC. Additional vias can be used to connect the top side ground area to the internal planes near the input and output capacitors. For operation at full rated load, the top side ground area along with any additional internal ground planes must provide adequate heat dissipating area.

Locate the input bypass capacitor as close to the IC as possible.

For two-layer board usage, VIN cap C1 should be very close to IC. The total routing distance to Vin and PGND pins combined <5mm. (Refer to EVM layout).

The PH pin should be routed to the output inductor. Since the PH connection is the switching node, the output inductor should be located very close to the PH pins, and the area of the PCB conductor minimized to prevent excessive capacitive coupling. The boot capacitor must also be located close to the device. To facilitate routing, the connection trace may be located on the back side or internal layer of the PCB. The sensitive analog ground connections for the feedback voltage divider, compensation components and slow start capacitor should be connected to a separate analog ground trace as shown. The additional external components can be placed approximately as shown. It may be possible to obtain acceptable performance with alternate PCB layouts, however this layout has been shown to produce good results and is meant as a guideline.

- VIA to Power Ground Plane
- ⊙ VIA to Internal or Bottom Layer Connection

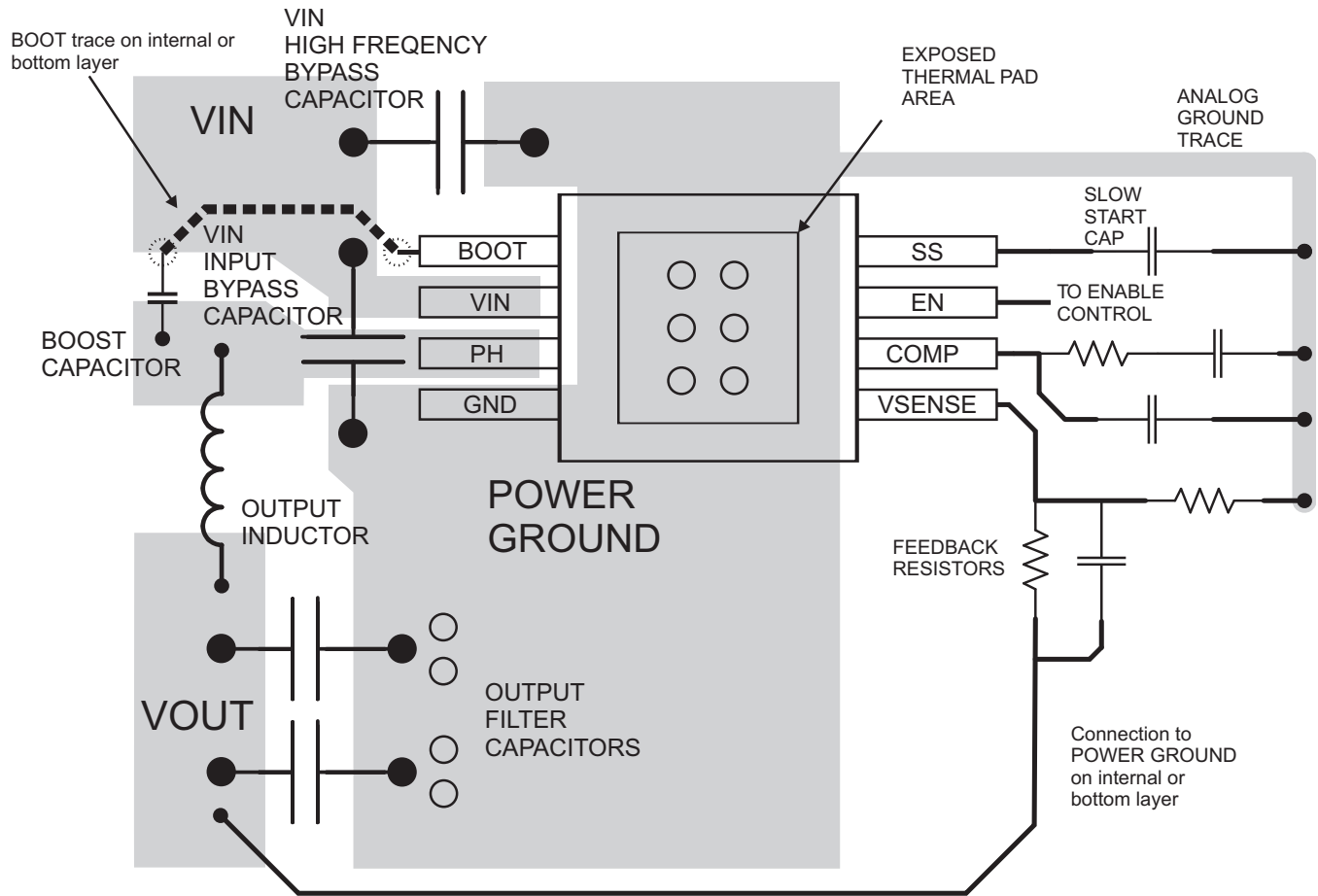

Figure 31. PCB Layout Example

## REVISION HISTORY

Note: Page numbers of current version may differ from previous versions.

<b>Changes from Original (March 2012) to Revision A</b>	<b>Page</b>
• Changed lower temperature range from –20°C to –40°C in the Reference Accuracy Over Temperature bullet .....	1
• Changed ESD HBM spec from 1 kV to 2 kV .....	3
• Changed temperature in the conditions statement for Voltage Reference spec from –20° to –40°C .....	4
• Changed L.S Switch resistance spec MAX value from 96 to 103 mΩ, for $V_{IN} = 5\text{ V}$ .....	4
• Changed L.S Switch resistance spec MAX value from 126 to 128 mΩ, for $V_{IN} = 2.95\text{ V}$ .....	4
• Changed I max Low side FET Current Limit MIN value from 1 to 0.8A and MAX value from 2 to 1.8A .....	4
• Added second paragraph to <a href="#">ENABLE AND UNDERVOLTAGE LOCKOUT section</a> . .....	11
• Added $I_p = 1.2\ \mu\text{A}$ to "Where" statement for <a href="#">Equation 3</a> .....	12
• Changed temperature value from 175°C to 170°C and 160°C to 155°C in the THERMAL SHUTDOWN description. ....	13

**PACKAGING INFORMATION**

Orderable Device	Status (1)	Package Type	Package Drawing	Pins	Package Qty	Eco Plan (2)	Lead finish/ Ball material (6)	MSL Peak Temp (3)	Op Temp (°C)	Device Marking (4/5)	Samples
TPS5432DDA	ACTIVE	SO PowerPAD	DDA	8	75	RoHS & Green	SN	Level-2-260C-1 YEAR	-40 to 125	5432	<a href="#">Samples</a>
TPS5432DDAR	ACTIVE	SO PowerPAD	DDA	8	2500	RoHS & Green	SN	Level-2-260C-1 YEAR	-40 to 125	5432	<a href="#">Samples</a>

(1) The marketing status values are defined as follows:

**ACTIVE:** Product device recommended for new designs.

**LIFEBUY:** TI has announced that the device will be discontinued, and a lifetime-buy period is in effect.

**NRND:** Not recommended for new designs. Device is in production to support existing customers, but TI does not recommend using this part in a new design.

**PREVIEW:** Device has been announced but is not in production. Samples may or may not be available.

**OBSOLETE:** TI has discontinued the production of the device.

(2) **RoHS:** TI defines "RoHS" to mean semiconductor products that are compliant with the current EU RoHS requirements for all 10 RoHS substances, including the requirement that RoHS substance do not exceed 0.1% by weight in homogeneous materials. Where designed to be soldered at high temperatures, "RoHS" products are suitable for use in specified lead-free processes. TI may reference these types of products as "Pb-Free".

**RoHS Exempt:** TI defines "RoHS Exempt" to mean products that contain lead but are compliant with EU RoHS pursuant to a specific EU RoHS exemption.

**Green:** TI defines "Green" to mean the content of Chlorine (Cl) and Bromine (Br) based flame retardants meet JS709B low halogen requirements of <=1000ppm threshold. Antimony trioxide based flame retardants must also meet the <=1000ppm threshold requirement.

(3) MSL, Peak Temp. - The Moisture Sensitivity Level rating according to the JEDEC industry standard classifications, and peak solder temperature.

(4) There may be additional marking, which relates to the logo, the lot trace code information, or the environmental category on the device.

(5) Multiple Device Markings will be inside parentheses. Only one Device Marking contained in parentheses and separated by a "~" will appear on a device. If a line is indented then it is a continuation of the previous line and the two combined represent the entire Device Marking for that device.

(6) Lead finish/Ball material - Orderable Devices may have multiple material finish options. Finish options are separated by a vertical ruled line. Lead finish/Ball material values may wrap to two lines if the finish value exceeds the maximum column width.

**Important Information and Disclaimer:**The information provided on this page represents TI's knowledge and belief as of the date that it is provided. TI bases its knowledge and belief on information provided by third parties, and makes no representation or warranty as to the accuracy of such information. Efforts are underway to better integrate information from third parties. TI has taken and continues to take reasonable steps to provide representative and accurate information but may not have conducted destructive testing or chemical analysis on incoming materials and chemicals. TI and TI suppliers consider certain information to be proprietary, and thus CAS numbers and other limited information may not be available for release.

In no event shall TI's liability arising out of such information exceed the total purchase price of the TI part(s) at issue in this document sold by TI to Customer on an annual basis.



**TAPE AND REEL INFORMATION**

**QUADRANT ASSIGNMENTS FOR PIN 1 ORIENTATION IN TAPE**

\*All dimensions are nominal

Device	Package Type	Package Drawing	Pins	SPQ	Reel Diameter (mm)	Reel Width W1 (mm)	A0 (mm)	B0 (mm)	K0 (mm)	P1 (mm)	W (mm)	Pin1 Quadrant
TPS5432DDAR	SO Power PAD	DDA	8	2500	330.0	12.8	6.4	5.2	2.1	8.0	12.0	Q1

**TAPE AND REEL BOX DIMENSIONS**



\*All dimensions are nominal

Device	Package Type	Package Drawing	Pins	SPQ	Length (mm)	Width (mm)	Height (mm)
TPS5432DDAR	SO PowerPAD	DDA	8	2500	366.0	364.0	50.0

**TUBE**

\*All dimensions are nominal

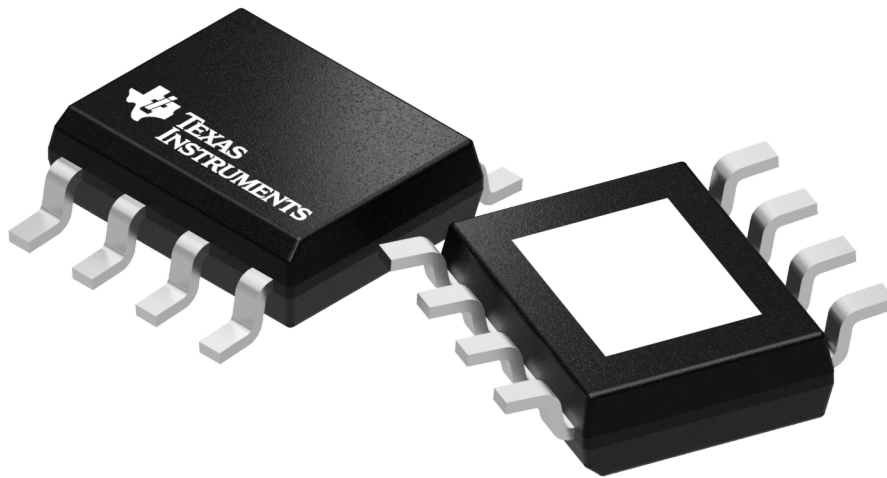
Device	Package Name	Package Type	Pins	SPQ	L (mm)	W (mm)	T (μm)	B (mm)
TPS5432DDA	DDA	HSOIC	8	75	517	7.87	635	4.25



Images above are just a representation of the package family, actual package may vary.  
Refer to the product data sheet for package details.

DDA (R-PDSO-G8)

PowerPAD™ PLASTIC SMALL-OUTLINE

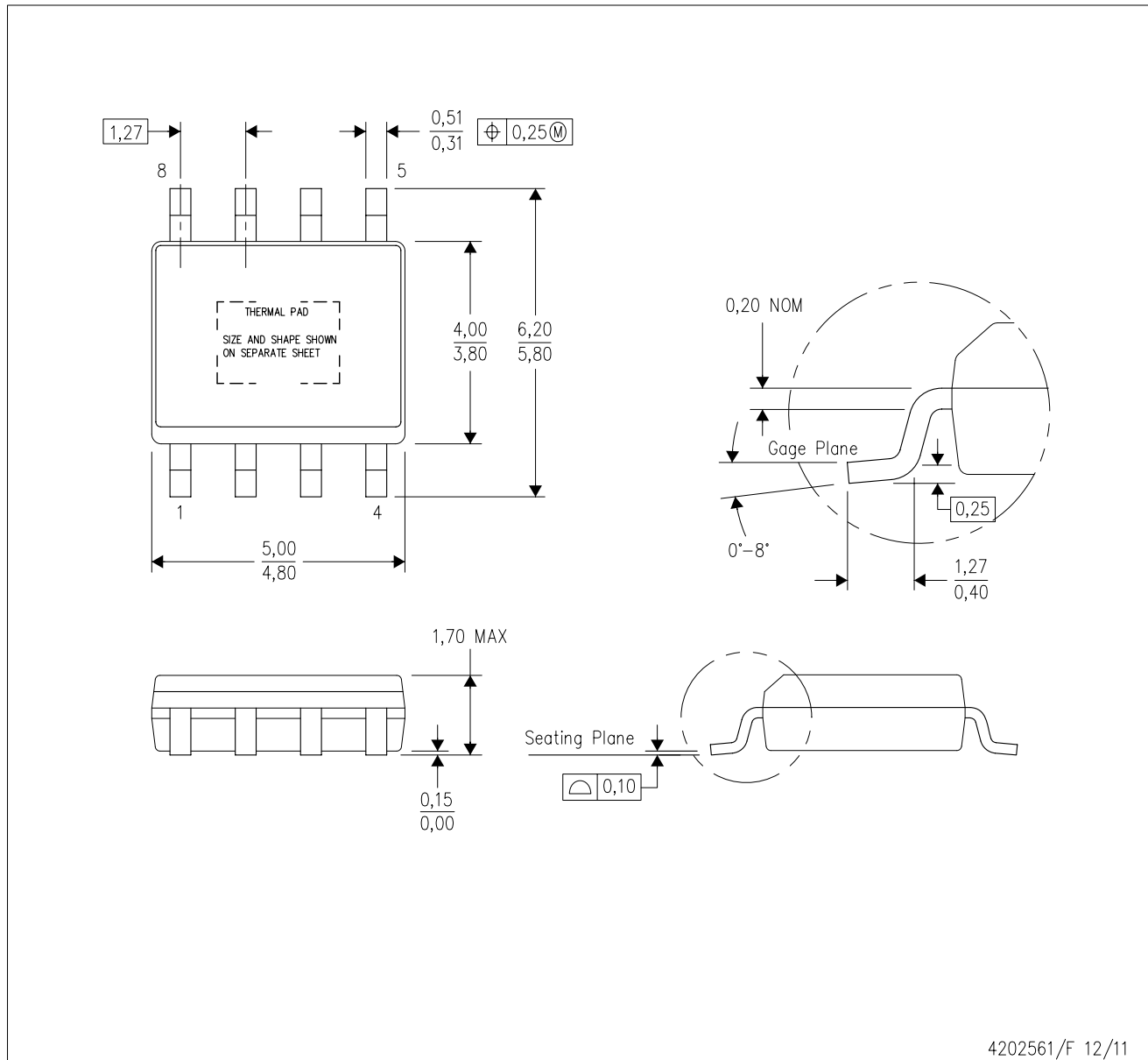

- NOTES:
- All linear dimensions are in millimeters. Dimensioning and tolerancing per ASME Y14.5-1994.
  - This drawing is subject to change without notice.
  - Body dimensions do not include mold flash or protrusion not to exceed 0,15.
  - This package is designed to be soldered to a thermal pad on the board. Refer to Technical Brief, PowerPad Thermally Enhanced Package, Texas Instruments Literature No. SLMA002 for information regarding recommended board layout. This document is available at [www.ti.com](http://www.ti.com) <<http://www.ti.com>>.
  - See the additional figure in the Product Data Sheet for details regarding the exposed thermal pad features and dimensions.
  - This package complies to JEDEC MS-012 variation BA

PowerPAD is a trademark of Texas Instruments.

DDA (R-PDSO-G8)

PowerPAD™ PLASTIC SMALL OUTLINE

## THERMAL INFORMATION

This PowerPAD™ package incorporates an exposed thermal pad that is designed to be attached to a printed circuit board (PCB). The thermal pad must be soldered directly to the PCB. After soldering, the PCB can be used as a heatsink. In addition, through the use of thermal vias, the thermal pad can be attached directly to the appropriate copper plane shown in the electrical schematic for the device, or alternatively, can be attached to a special heatsink structure designed into the PCB. This design optimizes the heat transfer from the integrated circuit (IC).

For additional information on the PowerPAD package and how to take advantage of its heat dissipating abilities, refer to Technical Brief, PowerPAD Thermally Enhanced Package, Texas Instruments Literature No. SLMA002 and Application Brief, PowerPAD Made Easy, Texas Instruments Literature No. SLMA004. Both documents are available at [www.ti.com](http://www.ti.com).

The exposed thermal pad dimensions for this package are shown in the following illustration.

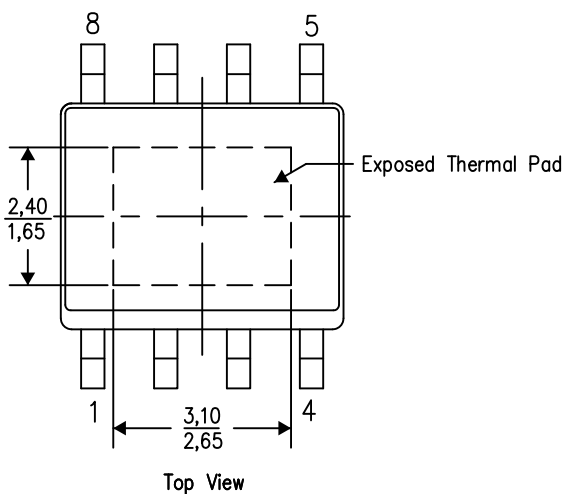

Exposed Thermal Pad Dimensions

4206322-6/L 05/12

NOTE: A. All linear dimensions are in millimeters

PowerPAD is a trademark of Texas Instruments

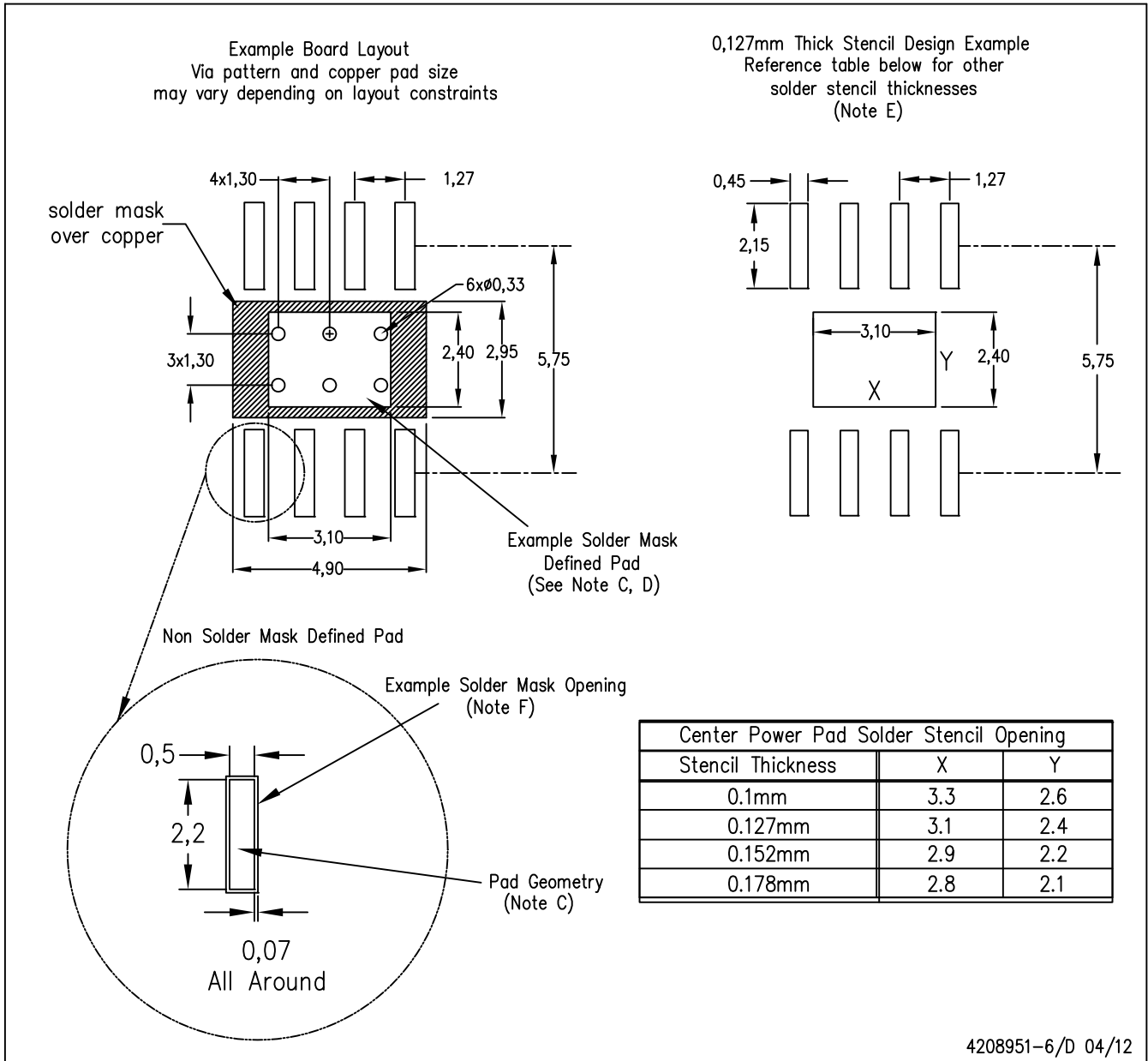

- NOTES:
- A. All linear dimensions are in millimeters.
  - B. This drawing is subject to change without notice.
  - C. Publication IPC-7351 is recommended for alternate designs.
  - D. This package is designed to be soldered to a thermal pad on the board. Refer to Technical Brief, PowerPad Thermally Enhanced Package, Texas Instruments Literature No. SLMA002, SLMA004, and also the Product Data Sheets for specific thermal information, via requirements, and recommended board layout. These documents are available at [www.ti.com](http://www.ti.com) <<http://www.ti.com>>. Publication IPC-7351 is recommended for alternate designs.
  - E. Laser cutting apertures with trapezoidal walls and also rounding corners will offer better paste release. Customers should contact their board assembly site for stencil design recommendations. Example stencil design based on a 50% volumetric metal load solder paste. Refer to IPC-7525 for other stencil recommendations.
  - F. Customers should contact their board fabrication site for solder mask tolerances between and around signal pads.

PowerPAD is a trademark of Texas Instruments.

## IMPORTANT NOTICE AND DISCLAIMER

TI PROVIDES TECHNICAL AND RELIABILITY DATA (INCLUDING DATA SHEETS), DESIGN RESOURCES (INCLUDING REFERENCE DESIGNS), APPLICATION OR OTHER DESIGN ADVICE, WEB TOOLS, SAFETY INFORMATION, AND OTHER RESOURCES "AS IS" AND WITH ALL FAULTS, AND DISCLAIMS ALL WARRANTIES, EXPRESS AND IMPLIED, INCLUDING WITHOUT LIMITATION ANY IMPLIED WARRANTIES OF MERCHANTABILITY, FITNESS FOR A PARTICULAR PURPOSE OR NON-INFRINGEMENT OF THIRD PARTY INTELLECTUAL PROPERTY RIGHTS.

These resources are intended for skilled developers designing with TI products. You are solely responsible for (1) selecting the appropriate TI products for your application, (2) designing, validating and testing your application, and (3) ensuring your application meets applicable standards, and any other safety, security, regulatory or other requirements.

These resources are subject to change without notice. TI grants you permission to use these resources only for development of an application that uses the TI products described in the resource. Other reproduction and display of these resources is prohibited. No license is granted to any other TI intellectual property right or to any third party intellectual property right. TI disclaims responsibility for, and you will fully indemnify TI and its representatives against, any claims, damages, costs, losses, and liabilities arising out of your use of these resources.

TI's products are provided subject to [TI's Terms of Sale](#) or other applicable terms available either on [ti.com](http://ti.com) or provided in conjunction with such TI products. TI's provision of these resources does not expand or otherwise alter TI's applicable warranties or warranty disclaimers for TI products.

TI objects to and rejects any additional or different terms you may have proposed.

Mailing Address: Texas Instruments, Post Office Box 655303, Dallas, Texas 75265  
Copyright © 2022, Texas Instruments Incorporated

## Looking for pricing, stock, or lifecycle information?

Click below to explore more details on WIN SOURCE:

 [View TPS5432DDAR](#) on WIN SOURCE

 [Texas Instruments](#) Information

## Optimize Your Supply Chain with WIN SOURCE Solutions

-  Global Sourcing Solution
-  Obsolete Management
-  Cost Control Management
-  Shortage Management
-  Alternative Solution
-  Excess Inventory Management