



**THE DATASHEET OF
TPS54332DDAR**



TPS54332 3.5-A, 28-V, 1-MHz, Step-Down DC/DC Converter With Eco-mode

1 Features

- 3.5-V to 28-V input voltage range
- Adjustable output voltage down to 0.8 V
- Integrated 80-mΩ high-side MOSFET supports up to 3.5-A continuous output current
- High-efficiency at light loads with a pulse-skipping Eco-mode
- Fixed 1-MHz switching frequency
- Typical 1-μA shutdown quiescent current
- Adjustable slow-start limits inrush currents
- Programmable UVLO threshold
- Overvoltage transient protection
- Cycle-by-cycle current limit, frequency foldback and thermal shutdown protection
- Available in thermally enhanced, 8-pin SOIC PowerPAD™ integrated circuit package
- Use [TPS62933](#) for a 30 VIN converter with higher frequency, lower IQ, and improved EMI
- Create a custom design using the TPS54332 with the [WEBENCH® Power Designer](#)

2 Applications

- Consumer applications such as set-top boxes, CPE equipment, LCD displays, peripherals, and battery chargers
- Industrial and car audio power supplies
- 5-V, 12-V and 24-V distributed power systems

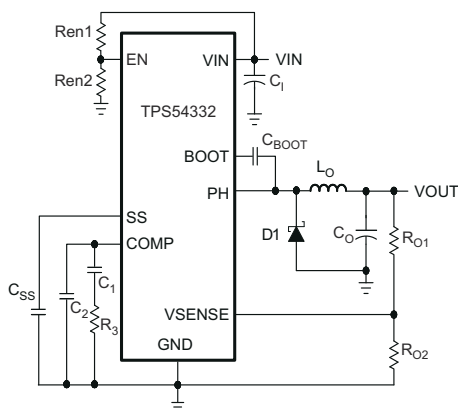

Simplified Schematic

3 Description

The TPS54332 is a 28-V, 3.5-A non-synchronous buck converter that integrates a low- $R_{DS(on)}$ high-side MOSFET. To increase efficiency at light loads, a pulse-skipping Eco-mode feature is automatically activated. Furthermore, the 1-μA shutdown supply current allows the device to be used in battery-powered applications. Current mode control with internal slope compensation simplifies the external compensation calculations and reduces component count while allowing the use of ceramic output capacitors. A resistor divider programs the hysteresis of the input undervoltage lockout. An overvoltage transient protection circuit limits voltage overshoots during start-up and transient conditions. A cycle-by-cycle current limit scheme, frequency foldback and thermal shutdown protect the device and the load in the event of an overload condition. The TPS54332 is available in an 8-pin SOIC PowerPAD integrated circuit package.

Package Information⁽¹⁾

PART NUMBER	PACKAGE	PACKAGE SIZE ⁽²⁾
TPS54332	DDA (SO PowerPAD, 8)	4.9 mm × 6 mm

- (1) For all available packages, see the orderable addendum at the end of the data sheet.
- (2) The package size (length × width) is a nominal value and includes pins, where applicable

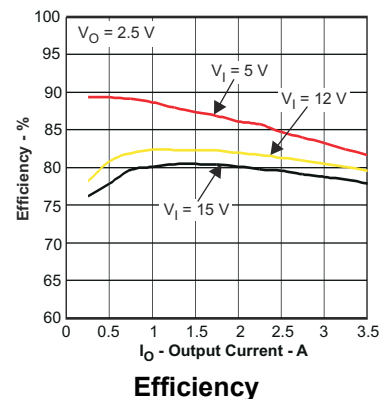

Table of Contents

1 Features	1	7.2 Functional Block Diagram.....	10
2 Applications	1	7.3 Feature Description.....	10
3 Description	1	7.4 Device Functional Modes.....	12
4 Revision History	2	8 Application and Implementation	14
5 Pin Configuration and Functions	3	8.1 Application Information.....	14
6 Specifications	4	8.2 Typical Application.....	14
6.1 Absolute Maximum Ratings.....	4	8.3 Power Supply Recommendations.....	23
6.2 ESD Ratings.....	4	8.4 Layout.....	23
6.3 Recommended Operating Conditions.....	4	9 Device and Documentation Support	25
6.4 Thermal Information.....	5	9.1 Device Support.....	25
6.5 Electrical Characteristics.....	6	9.2 Support Resources.....	25
6.6 Switching Characteristics.....	6	9.3 Receiving Notification of Documentation Updates.....	25
6.7 Typical Characteristics: Characterization Curves.....	7	9.4 Trademarks.....	25
6.8 Typical Characteristics: Supplemental Application Curves.....	8	9.5 Electrostatic Discharge Caution.....	25
7 Detailed Description	9	9.6 Glossary.....	25
7.1 Overview.....	9	10 Mechanical, Packaging, and Orderable Information	25

4 Revision History

NOTE: Page numbers for previous revisions may differ from page numbers in the current version.

Changes from Revision C (November 2014) to Revision D (September 2023)	Page
• Updated the numbering format for tables, figures, and cross-references throughout the document	1
• Add TPS62933 information to the <i>Features</i>	1
• Change column title from BODY SIZE to PACKAGE SIZE in the <i>Package Information</i> table.....	1
• Updated trademark information.....	1
• Moved storage temperature to the <i>Absolute Maximum Ratings</i> table.....	4
• Change table title from <i>Handling Ratings</i> to <i>ESD Ratings</i>	4
• Add WEBENCH information in the <i>Development Support</i> section.....	25

Changes from Revision B (February 2012) to Revision C (November 2014)	Page
• Added <i>Pin Configuration and Functions</i> section, <i>Handling Rating</i> table, <i>Feature Description</i> section, <i>Device Functional Modes</i> , <i>Application and Implementation</i> section, <i>Power Supply Recommendations</i> section, <i>Layout</i> section, <i>Device and Documentation Support</i> section, and <i>Mechanical, Packaging, and Orderable Information</i> section	1

Changes from Revision A (January 2013) to Revision B (February 2012)	Page
• Deleted feature Item: For SWIFT™ Documentation, See the TI Website at www.ti.com/swift	1

5 Pin Configuration and Functions

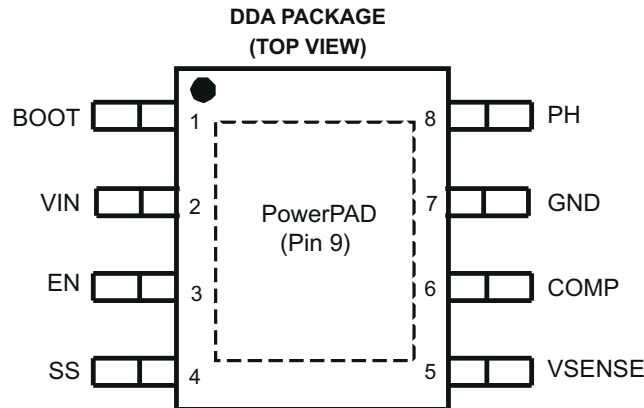

Figure 5-1. DDA Package, 8-Pin SO PowerPAD™ Integrated Circuit Package (Top View)

Table 5-1. Pin Functions

PIN		I/O	DESCRIPTION
NAME	NO.		
BOOT	1	O	A 0.1- μ F bootstrap capacitor is required between BOOT and PH. If the voltage on this capacitor falls below the minimum requirement, the high-side MOSFET is forced to switch off until the capacitor is refreshed.
VIN	2	I	Input supply voltage, 3.5 V to 28 V.
EN	3	I	Enable pin. Pull below 1.25 V to disable. Float to enable. TI recommends programming the input undervoltage lockout with two resistors.
SS	4	I	Slow-start pin. An external capacitor connected to this pin sets the output rise time.
VSENSE	5	I	Inverting node of the gm error amplifier.
COMP	6	O	Error amplifier output, and input to the PWM comparator. Connect frequency compensation components to this pin.
GND	7	—	Ground
PH	8	O	The source of the internal high-side power MOSFET
PowerPAD	9	—	GND pin must be connected to the exposed pad for proper operation.

6 Specifications

6.1 Absolute Maximum Ratings

over operating free-air temperature range (unless otherwise noted) ⁽¹⁾

		MIN	MAX	UNIT
Input Voltage	VIN	-0.3	30	V
	EN	-0.3	6	
	BOOT		38	
	VSENSE	-0.3	3	
	COMP	-0.3	3	
	SS	-0.3	3	
Output Voltage	BOOT-PH		8	V
	PH	-0.6	30	
	PH (10-ns transient from ground to negative peak)		-5	
Source Current	EN		100	μA
	BOOT		100	mA
	VSENSE		10	μA
	PH		9.25	A
Sink Current	VIN		9.25	A
	COMP		100	μA
	SS		200	
Operating Junction Temperature		-40	150	°C
Storage temperature		-65	150	°C

- (1) Stresses beyond those listed under *Absolute Maximum Ratings* may cause permanent damage to the device. These are stress ratings only, which do not imply functional operation of the device at these or any other conditions beyond those indicated under *Recommended Operating Conditions*. Exposure to absolute-maximum-rated conditions for extended periods may affect device reliability.

6.2 ESD Ratings

		MIN	MAX	UNIT
V _(ESD)	Electrostatic Discharge	Human body model (HBM), per ANSI/ESDA/JEDEC JS-001, all pins ⁽¹⁾	2	kV
		Charged device model (CDM), per JEDEC specification JESD22-C101, all pins ⁽²⁾	500	V

- (1) JEDEC document JEP155 states that 500-V HBM allows safe manufacturing with a standard ESD control process.

- (2) JEDEC document JEP157 states that 250-V CDM allows safe manufacturing with a standard ESD control process.

6.3 Recommended Operating Conditions

over operating free-air temperature range (unless otherwise noted)

	MIN	MAX	UNIT
Operating Input Voltage on (VIN pin)	3.5	28	V
Operating junction temperature, T _j	-40	150	°C

6.4 Thermal Information

THERMAL METRIC ⁽¹⁾		TPS54332	UNIT
		HSOP	
		8 PINS	
$R_{\theta JA}$	Junction-to-ambient thermal resistance	48.7	°C/W
$R_{\theta JC(top)}$	Junction-to-case (top) thermal resistance	52.4	
$R_{\theta JB}$	Junction-to-board thermal resistance	25.3	
Ψ_{JT}	Junction-to-top characterization parameter	8.4	
Ψ_{JB}	Junction-to-board characterization parameter	25.2	
$R_{\theta JC(bot)}$	Junction-to-case (bottom) thermal resistance	2.3	

(1) For more information about traditional and new thermal metrics, see the *IC Package Thermal Metrics* application report, [SPRA953](#).

6.5 Electrical Characteristics

$T_J = -40^{\circ}\text{C}$ to 150°C , $V_{IN} = 3.5\text{ V}$ to 28 V (unless otherwise noted)

DESCRIPTION	TEST CONDITIONS	MIN	TYP	MAX	UNIT
SUPPLY VOLTAGE (VIN PIN)					
Internal undervoltage lockout threshold	Rising and Falling			3.5	V
Shutdown supply current	EN = 0 V, $V_{IN} = 12\text{ V}$, -40°C to 85°C		1	4	μA
Operating – non switching supply current	VSENSE = 0.85 V		82	120	μA
ENABLE AND UVLO (EN PIN)					
Enable threshold	Rising and Falling		1.25	1.35	V
Input current	Enable threshold – 50 mV		-1		μA
Input current	Enable threshold + 50 mV		-4		μA
VOLTAGE REFERENCE					
Voltage reference		0.772	0.8	0.828	V
HIGH-SIDE MOSFET					
On resistance	BOOT-PH = 3 V, $V_{IN} = 3.5\text{ V}$		115	200	$\text{m}\Omega$
	BOOT-PH = 6 V, $V_{IN} = 12\text{ V}$		80	150	
ERROR AMPLIFIER					
Error amplifier transconductance (gm)	$-2\ \mu\text{A} < I_{\text{COMP}} < 2\ \mu\text{A}$, $V(\text{COMP}) = 1\text{ V}$		92		μmhos
Error amplifier DC gain ⁽¹⁾	VSENSE = 0.8 V		800		V/V
Error amplifier unity gain bandwidth ⁽¹⁾	5 pF capacitance from COMP to GND pins		2.7		MHz
Error amplifier source/sink current	$V(\text{COMP}) = 1.0\text{ V}$, 100-mV overdrive		± 7		μA
Switch current to COMP transconductance	$V_{IN} = 12\text{ V}$		12		A/V
PULSE-SKIPPING ECO-MODE					
Pulse-skipping Eco-mode switch current threshold			160		mA
CURRENT LIMIT					
Current limit threshold	$V_{IN} = 12\text{ V}$	4.2	6.5		A
THERMAL SHUTDOWN					
Thermal Shutdown			165		$^{\circ}\text{C}$
SLOW-START (SS PIN)					
Charge current	$V_{(\text{SS})} = 0.4\text{ V}$		2		μA
SS to VSENSE matching	$V_{(\text{SS})} = 0.4\text{ V}$		10		mV

(1) Specified by design

6.6 Switching Characteristics

PARAMETERS ⁽¹⁾	TEST CONDITIONS	MIN	TYP	MAX	UNIT
TPS54332 Switching Frequency	$V_{IN} = 12\text{ V}$, 25°C	800	1000	1200	kHz
Minimum controllable on time	$V_{IN} = 12\text{ V}$, 25°C		110	135	ns
Maximum controllable duty ratio ⁽¹⁾	BOOT-PH = 6 V	90%	93%		

(1) Specified by design

6.7 Typical Characteristics: Characterization Curves

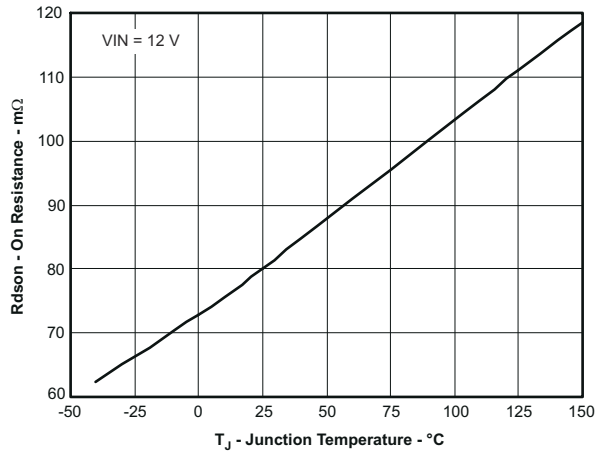

Figure 6-1. On Resistance vs Junction Temperature

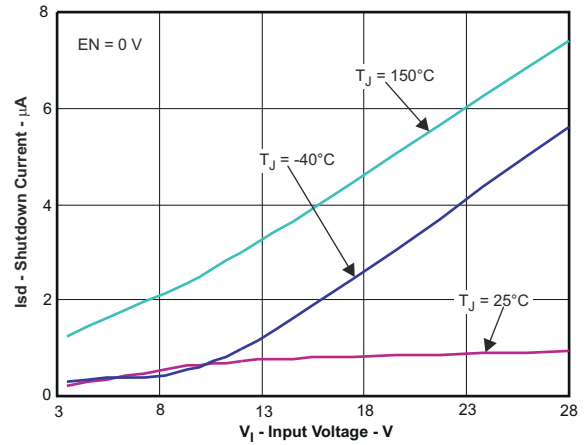

Figure 6-2. Shutdown Quiescent Current vs Input Voltage

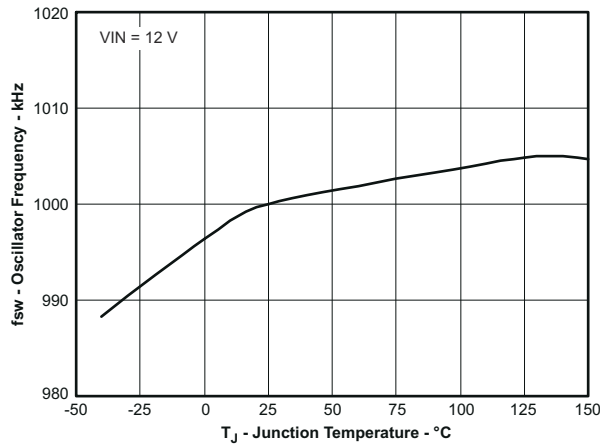

Figure 6-3. Switching Frequency vs Junction Temperature

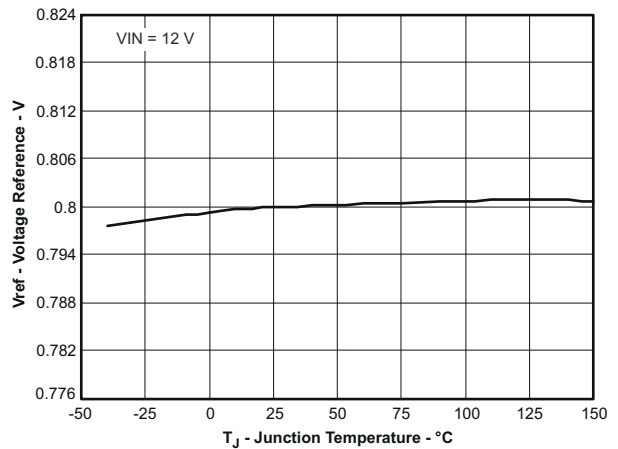

Figure 6-4. Voltage Reference vs Junction Temperature

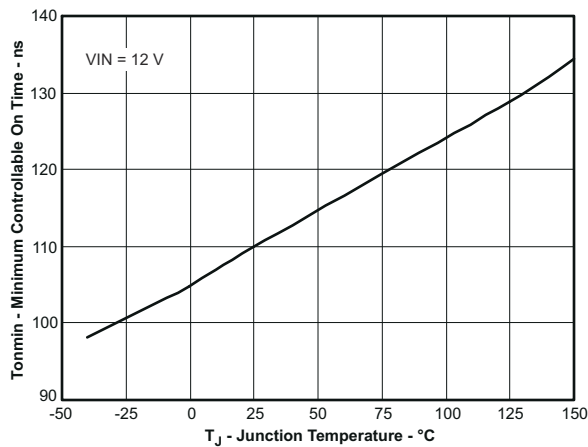

Figure 6-5. Minimum Controllable on Time vs Junction Temperature

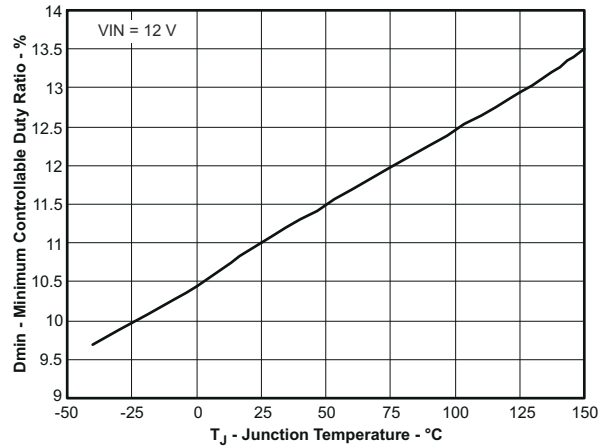
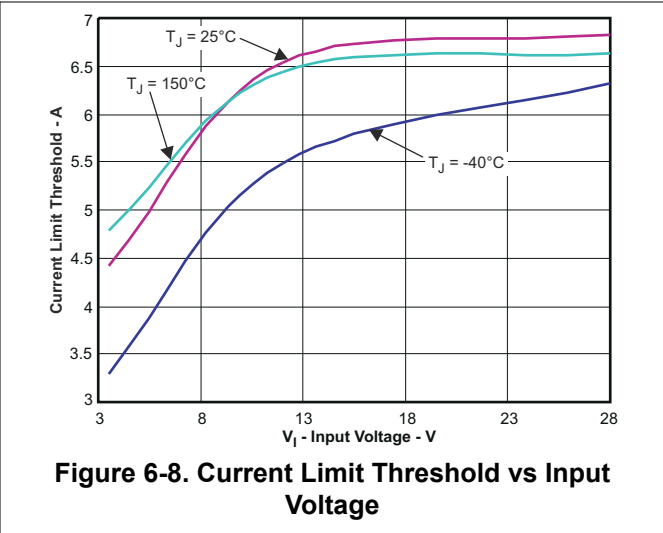
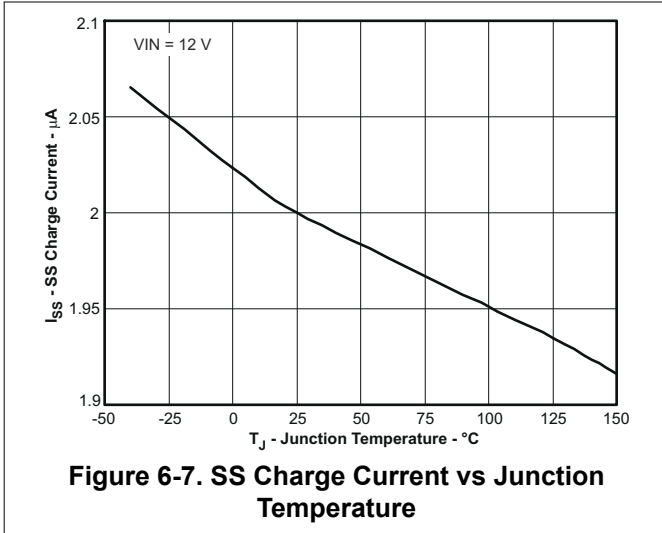
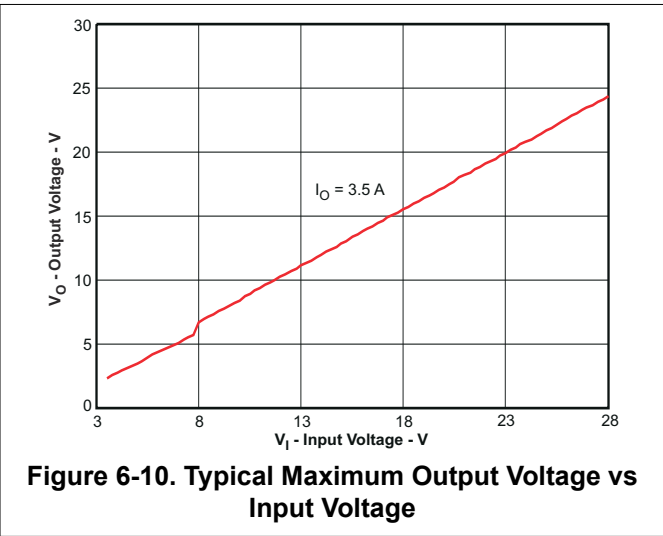
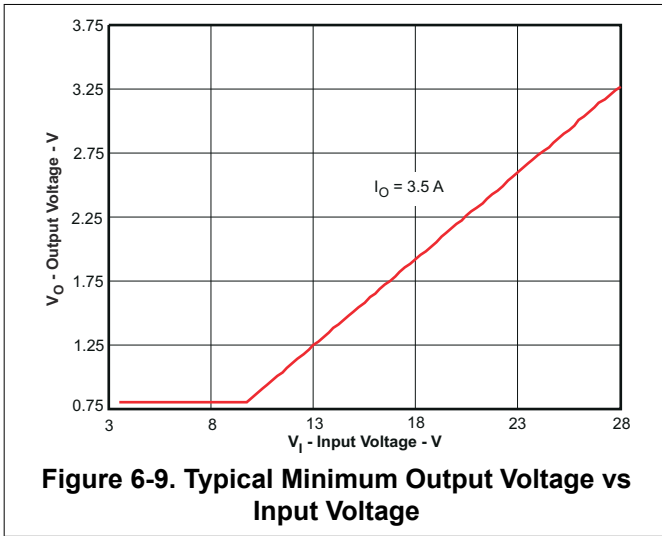

Figure 6-6. Minimum Controllable Duty Ratio vs Junction Temperature



6.8 Typical Characteristics: Supplemental Application Curves



7 Detailed Description

7.1 Overview

The TPS54332 is a 28-V, 3.5-A, step-down (buck) converter with an integrated high-side, N-channel MOSFET. To improve performance during line and load transients, the device implements a constant-frequency, current mode control, which reduces output capacitance and simplifies external frequency compensation design. The TPS54332 has a preset switching frequency of 1 MHz.

The TPS54332 needs a minimum input voltage of 3.5 V to operate normally. The EN pin has an internal pullup current source that can be used to adjust the input voltage undervoltage lockout (UVLO) with two external resistors. In addition, the pullup current provides a default condition when the EN pin is floating for the device to operate. The operating current is 82 μ A typically when not switching and under no load. When the device is disabled, the supply current is 1 μ A typically.

The integrated 80-m Ω high-side MOSFET allows for high-efficiency power supply designs with continuous output currents up to 3.5 A.

The TPS54332 reduces the external component count by integrating the boot recharge diode. The bias voltage for the integrated high-side MOSFET is supplied by an external capacitor on the BOOT to PH pin. The boot capacitor voltage is monitored by an UVLO circuit and turns the high-side MOSFET off when the voltage falls below a preset threshold of 2.1 V typically. The output voltage can be stepped down to as low as the reference voltage.

By adding an external capacitor, the slow-start time of the TPS54332 can be adjustable which enables flexible output filter selection.

To improve the efficiency at light load conditions, the TPS54332 enters a special pulse-skipping Eco-mode when the peak inductor current drops below 160 mA typically.

The frequency foldback reduces the switching frequency during start-up and overcurrent conditions to help control the inductor current. The thermal shutdown gives the additional protection under fault conditions.

7.2 Functional Block Diagram

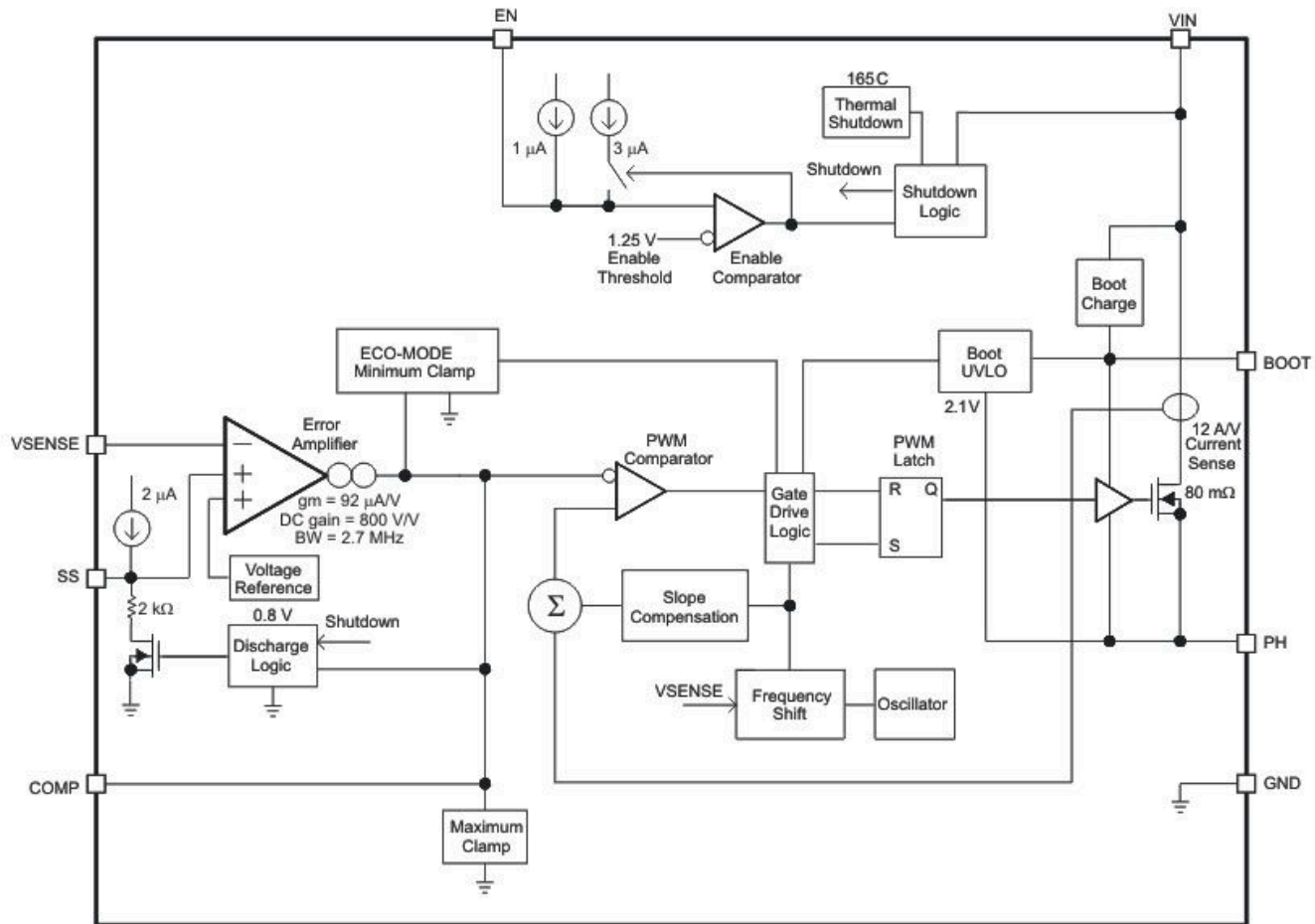

7.3 Feature Description

7.3.1 Fixed Frequency PWM Control

The TPS54332 uses a fixed-frequency, peak-current mode control. The internal switching frequency of the TPS54332 is fixed at 1 MHz.

7.3.2 Voltage Reference (V_{ref})

The voltage reference system produces a $\pm 2\%$ initial accuracy voltage reference ($\pm 3.5\%$ over temperature) by scaling the output of a temperature stable band-gap circuit. The typical voltage reference is designed at 0.8 V.

7.3.3 Bootstrap Voltage (BOOT)

The TPS54332 has an integrated boot regulator and requires a 0.1- μF ceramic capacitor between the BOOT and PH pin to provide the gate drive voltage for the high-side MOSFET. A ceramic capacitor with an X7R or X5R grade dielectric is recommended because of the stable characteristics over temperature and voltage. To improve dropout, the TPS54332 is designed to operate at 100% duty cycle as long as the BOOT to PH pin voltage is greater than 2.1 V typically.

7.3.4 Enable and Adjustable Input Undervoltage Lockout (V_{IN} UVLO)

The EN pin has an internal pullup current source that provides the default condition of the TPS54332 operating when the EN pin floats.

The TPS54332 is disabled when the VIN pin voltage falls below internal VIN UVLO threshold. TI recommends using an external VIN UVLO to add Hysteresis unless VIN is greater than ($V_{OUT} + 2$ V). To adjust the VIN UVLO with Hysteresis, use the external circuitry connected to the EN pin as shown in [Figure 7-1](#). After the EN pin

voltage exceeds 1.25 V, an additional 3 μA of hysteresis is added. Use [Equation 1](#) and [Equation 2](#) to calculate the resistor values needed for the desired VIN UVLO threshold voltages. The V_{START} is the input start threshold voltage, the V_{STOP} is the input stop threshold voltage and the V_{EN} is the enable threshold voltage of 1.25 V. The V_{STOP} must always be greater than 3.5 V.

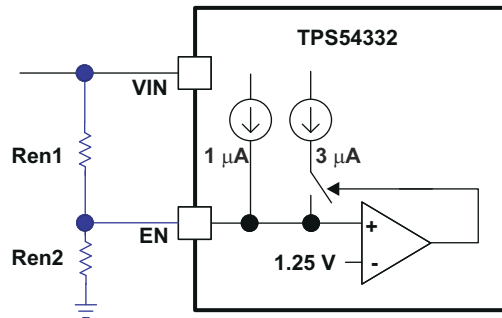

$$\text{Ren1} = \frac{V_{\text{START}} - V_{\text{STOP}}}{3\mu\text{A}} \quad (1)$$

$$\text{Ren2} = \frac{V_{\text{EN}}}{\frac{V_{\text{START}} - V_{\text{EN}}}{\text{Ren1}} + 1\mu\text{A}} \quad (2)$$

Figure 7-1. Adjustable Input Undervoltage Lockout

7.3.5 Programmable Slow Start Using the SS Pin

TI highly recommends programming the slow-start time externally because no slow-start time is implemented internally. The TPS54332 effectively uses the lower voltage of the internal voltage reference or the SS pin voltage as the power supply reference voltage fed into the error amplifier and regulates the output accordingly. A capacitor (C_{SS}) on the SS pin-to-ground implements a slow-start time. The TPS54332 has an internal pullup current source of 2 μA that charges the external slow-start capacitor. The equation for the slow-start time (10% to 90%) is shown in [Equation 3](#). The V_{ref} is 0.8 V and the I_{SS} current is 2 μA .

$$T_{\text{SS}}(\text{ms}) = \frac{C_{\text{SS}}(\text{nF}) \times V_{\text{REF}}(\text{V})}{I_{\text{SS}}(\mu\text{A})} \quad (3)$$

The slow-start time must be set between 1 ms to 10 ms to make sure of good start-up behavior. The slow-start capacitor must be no more than 27 nF.

If during normal operation, the input voltage drops below the VIN UVLO threshold, or the EN pin is pulled below 1.25 V, or a thermal shutdown event occurs, the TPS54332 stops switching.

7.3.6 Error Amplifier

The TPS54332 has a transconductance amplifier for the error amplifier. The error amplifier compares the V_{SENSE} voltage to the internal effective voltage reference presented at the input of the error amplifier. The transconductance of the error amplifier is 92 $\mu\text{A}/\text{V}$ during normal operation. Frequency compensation components are connected between the COMP pin and ground.

7.3.7 Slope Compensation

To prevent the sub-harmonic oscillations when operating the device at duty cycles greater than 50%, the TPS54332 adds a built-in slope compensation which is a compensating ramp to the switch current signal.

7.3.8 Current Mode Compensation Design

To simplify design efforts using the TPS54332, the typical designs for common applications are listed in [Table 7-1](#). For designs using ceramic output capacitors, TI recommends proper derating of ceramic output capacitance when doing the stability analysis. This recommendation is because the actual ceramic capacitance drops considerably from the nominal value when the applied voltage increases. Advanced users can refer to the

[Detailed Design Procedure](#) in the [Application and Implementation](#) section for the detailed guidelines, or use the [WEBENCH](#) tool.

Table 7-1. Typical Designs (Referring to Simplified Schematic on Page 1)

V _{IN} (V)	V _{OUT} (V)	F _{sw} (kHz)	L _o (μH)	C _o	R _{O1} (kΩ)	R _{O2} (kΩ)	C ₂ (pF)	C ₁ (pF)	R ₃ (kΩ)
12	5	1000	3.3	Ceramic 22-μF	10	1.91	18	470	24.9
12	3.3	1000	2.7	Ceramic 22 μF × 2	10	3.24	18	1800	39.2
12	5	1000	3.3	Aluminum 330 μF / 160mohm	10	1.91	22	47	10
12	3.3	1000	2.7	Aluminum 330 μF / 160 mohm	10	3.24	39	100	29.4

7.3.9 Overcurrent Protection and Frequency Shift

The TPS54332 implements current mode control that uses the COMP pin voltage to turn off the high-side MOSFET on a cycle-by-cycle basis. Every cycle, the switch current and the COMP pin voltage are compared; when the peak inductor current intersects the COMP pin voltage, the high-side switch is turned off. During overcurrent conditions that pull the output voltage low, the error amplifier responds by driving the COMP pin high, causing the switch current to increase. The COMP pin has a maximum clamp internally, which limit the output current.

The TPS54332 provides robust protection during short circuits. There is potential for overcurrent runaway in the output inductor during a short circuit at the output. The TPS54332 solves this issue by increasing the off-time during short circuit conditions by lowering the switching frequency. The switching frequency is divided by 8, 4, 2, and 1 as the voltage ramps from 0 V to 0.8 V on VSENSE pin. The relationship between the switching frequency and the VSENSE pin voltage is shown in [Table 7-2](#).

Table 7-2. Switching Frequency Conditions

SWITCHING FREQUENCY	VSENSE PIN VOLTAGE
1 MHz	VSENSE ≥ 0.6 V
1 MHz / 2	0.6 V > VSENSE ≥ 0.4 V
1 MHz / 4	0.4 V > VSENSE ≥ 0.2 V
1 MHz / 8	0.2 V > VSENSE

7.3.10 Overvoltage Transient Protection

The TPS54332 incorporates an overvoltage transient protection (OVTP) circuit to minimize output voltage overshoot when recovering from output fault conditions or strong unload transients. The OVTP circuit includes an overvoltage comparator to compare the VSENSE pin voltage and internal thresholds. When the VSENSE pin voltage goes above 109% × V_{ref}, the high-side MOSFET is forced off. When the VSENSE pin voltage falls below 107% × V_{ref}, the high-side MOSFET is enabled again.

7.3.11 Thermal Shutdown

The device implements an internal thermal shutdown to protect itself if the junction temperature exceeds 165°C. The thermal shutdown forces the device to stop switching when the junction temperature exceeds the thermal trip threshold. After the die temperature decreases below 165°C, the device reinitiates the power-up sequence.

7.4 Device Functional Modes

7.4.1 Operation With VIN < 3.5 V

TI recommends the device operate with input voltages above 3.5 V. The typical VIN UVLO threshold is not specified and the device can operate at input voltages down to the UVLO voltage. At input voltages below the actual UVLO voltage, the device does not switch. If EN is externally pulled up or left floating, when VIN passes the UVLO threshold the device becomes active. Switching commences when the soft-start sequence is initiated.

7.4.2 Operation With EN Control

The enable threshold voltage is 1.25 V typical. With EN held below that voltage the device is disabled and switching is inhibited even if VIN is above its UVLO threshold. The IC quiescent current is reduced in this state.

If the EN voltage is increased above the threshold while VIN is above its UVLO threshold, the device becomes active. Switching is enabled, and the slow-start sequence is initiated.

7.4.3 Eco-mode

The device is designed to operate in pulse-skipping Eco-mode at light-load currents to boost light-load efficiency. When the peak inductor current is lower than pulse skip threshold, the COMP pin voltage falls to 0.5 V (typical) and the device enters Eco-mode. When the device is in Eco-mode, the COMP pin voltage is clamped at 0.5 V internally which prevents the high-side integrated MOSFET from switching. The peak inductor current must rise above 160 mA for the COMP pin voltage to rise above 0.5 V and exit Eco-mode. Because the integrated current comparator catches the peak inductor current only, the average load current entering Eco-mode varies with the applications and external output filters.

8 Application and Implementation

Note

Information in the following applications sections is not part of the TI component specification, and TI does not warrant its accuracy or completeness. TI's customers are responsible for determining suitability of components for their purposes, as well as validating and testing their design implementation to confirm system functionality.

8.1 Application Information

The TPS54332 is typically used as step-down converters, which convert a voltage from 3.5 V – 28 V to a lower voltage. WEBENCH software is available to aid in the design and analysis of circuits.

	TPS54231	TPS54232	TPS54233	TPS54331	TPS54332
I _O (maximum)	2 A	2 A	2 A	3 A	3.5 A
Input voltage range	3.5 V – 28 V	3.5 V – 28 V	3.5 V – 28 V	3.5 V – 28 V	3.5 V – 28 V
Switching frequency (typical)	570 kHz	1000 kHz	285 kHz	570 kHz	1000 kHz
Switch current limit (minimum)	2.3 A	2.3 A	2.3 A	3.5 A	4.2 A
Pin, package	8, SOIC	8, SOIC	8, SOIC	8, SOIC	8, SO PowerPAD integrated circuit package

8.2 Typical Application

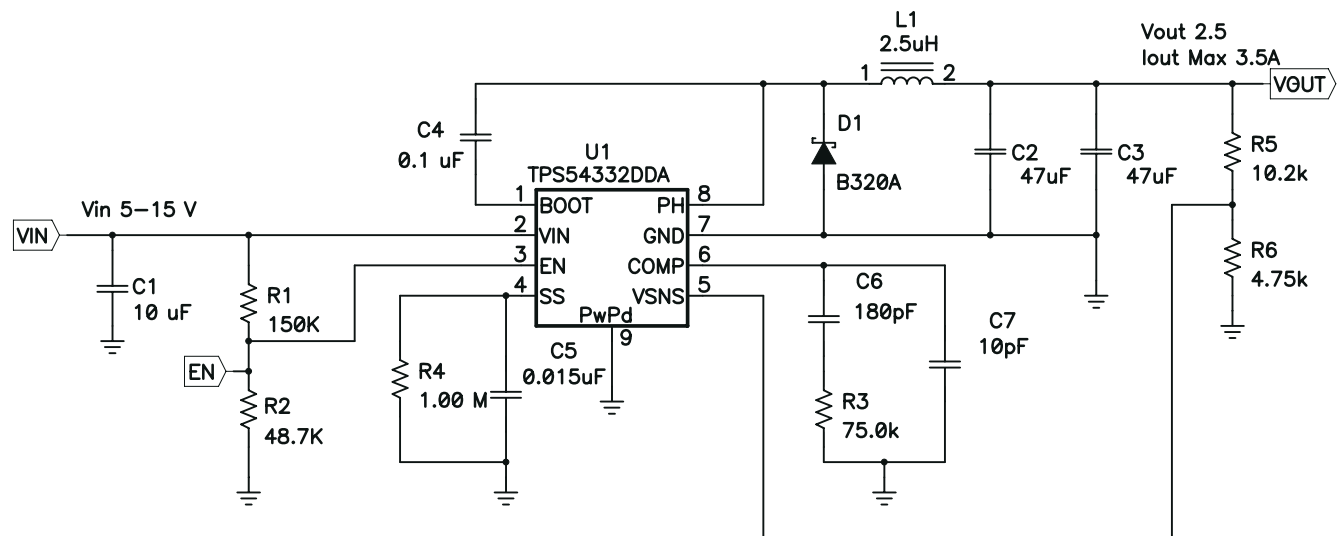

Figure 8-1. Typical Application Schematic

8.2.1 Design Requirements

For this design example, use the following as the input parameters:

DESIGN PARAMETER	EXAMPLE VALUE
Input voltage range	5 V to 15 V
Output voltage	2.5 V
Input ripple voltage	200 mV
Output ripple voltage	20 mV
Output current rating	3.5 A

DESIGN PARAMETER	EXAMPLE VALUE
Operating Frequency	1 MHz

8.2.2 Detailed Design Procedure

The following design procedure can be used to select component values for the TPS54332. Alternately, the WEBENCH Tool can be used to generate a complete design. The WEBENCH Tool uses an iterative design procedure and accesses a comprehensive database of components when generating a design. This section presents a simplified discussion of the design process.

8.2.2.1 Custom Design with WEBENCH® Tools

Create a custom design with the TPS54332 using the [WEBENCH® Power Designer](#)

1. Start by entering the input voltage (Vin), output voltage (Vout), and output current (Iout) requirements.
2. Optimize the design for key parameters such as efficiency, footprint, and cost using the optimizer dial.
3. Compare the generated design with other possible solutions from Texas Instruments.

The WEBENCH Power Designer gives a customized schematic along with a list of materials with real-time pricing and component availability.

In most cases, these actions are available:

- Run electrical simulations to see important waveforms and circuit performance
- Run thermal simulations to understand board thermal performance
- Export customized schematic and layout into popular CAD formats
- Print PDF reports for the design, and share the design with colleagues

Get more information about WEBENCH tools at www.ti.com/WEBENCH.

8.2.2.2 Switching Frequency

The switching frequency for the TPS54332 is fixed at 1 MHz.

8.2.2.3 Output Voltage Set Point

The output voltage of the TPS54332 is externally adjustable using a resistor divider network. In the application circuit of [Figure 8-1](#), this divider network is comprised of R5 and R6. The relationship of the output voltage to the resistor divider is given by [Equation 4](#) and [Equation 5](#).

$$R6 = \frac{R5 \times V_{REF}}{V_{OUT} - V_{REF}} \quad (4)$$

$$V_{OUT} = V_{REF} \times \left(\frac{R5}{R6} + 1 \right) \quad (5)$$

Choose R5 to be approximately 10 kΩ. Slightly increasing or decreasing R5 can result in closer output voltage matching when using standard value resistors. In this design, R4 = 10.2 kΩ and R = 4.75 kΩ, resulting in a 2.5-V output voltage.

8.2.2.4 Input Capacitors

The TPS54332 requires an input decoupling capacitor and depending on the application, a bulk-input capacitor. The typical recommended value for the decoupling capacitor is 10 μF. TI recommends a high-quality ceramic type X5R or X7R. The voltage rating must be greater than the maximum input voltage. A smaller value can be used as long as all other requirements are met; however 10 μF has been shown to work well in a wide variety of circuits. Additionally, some bulk capacitance can be needed, especially if the TPS54332 circuit is not located within about 2 inches from the input voltage source. The value for this capacitor is not critical but must be rated to handle the maximum input voltage including ripple voltage, and must filter the output so that input ripple voltage is acceptable. For this design, a single 10-μF capacitor is used for the input decoupling capacitor that is X5R dielectric rated for 25 V. The equivalent series resistance (ESR) is approximately 3 mΩ, and the current rating is 3 A.

This input ripple voltage can be approximated by [Equation 6](#).

$$\Delta V_{IN} = \frac{I_{OUT(MAX)} \times 0.25}{C_{BULK} \times F_{SW}} + (I_{OUT(MAX)} \times ESR_{MAX}) \quad (6)$$

Where $I_{OUT(MAX)}$ is the maximum load current, f_{SW} is the switching frequency (derated by a factor of 0.8), C_{BULK} is the bulk capacitor value and ESR_{MAX} is the maximum series resistance of the bulk capacitor.

The maximum RMS input ripple current also needs to be checked. For worst case conditions, this can be approximated by [Equation 7](#).

$$I_{CIN} = \frac{I_{OUT(MAX)}}{2} \quad (7)$$

In this case, the input ripple voltage is 98 mV and the RMS ripple current is 1.75 A. Make sure to note that the actual input voltage ripple is greatly affected by parasitic associated with the layout and the output impedance of the voltage source. The actual input voltage ripple for this circuit is shown in [Design Parameters](#) and is larger than the calculated value. This measured value is still below the specified input limit of 200 mV. The maximum voltage across the input capacitors is $V_{IN\ max}$ plus $\Delta V_{IN}/2$. The chosen bypass capacitor is rated for 25 V and the ripple current capacity is greater than 3 A, providing ample margin. Make sure that the maximum ratings for voltage and current are not exceeded under any circumstance.

8.2.2.5 Output Filter Components

Select two components for the output filter, the output inductor L1, and the output capacitance. Because the TPS54332 is an externally compensated device, a wide range of filter component types and values can be supported.

8.2.2.6 Inductor Selection

To calculate the minimum value of the output inductor, use [Equation 8](#).

$$L_{MIN} = \frac{V_{OUT(MAX)} \times (V_{IN(MAX)} - V_{OUT})}{V_{IN(MAX)} \times K_{IND} \times I_{OUT} \times F_{SW} \times 0.8} \quad (8)$$

K_{IND} is a coefficient that represents the amount of inductor ripple current relative to the maximum output current. In general, this value is at the discretion of the designer; however, the following guidelines can be used. For designs using low-ESR output capacitors such as ceramics, a value as high as $K_{IND} = 0.4$ can be used. When using higher ESR output capacitors, $K_{IND} = 0.2$ yields better results.

For this design example, use $K_{IND} = 0.3$ and the minimum inductor value is calculated to be 2.48 μ H. For this design, a 12.5- μ H inductor is chosen.

For the output filter inductor, make sure that the RMS current and saturation current ratings not be exceeded. The peak-to-peak inductor current is calculated using [Equation 9](#).

$$I_{LPP} = \frac{V_{OUT} \times (V_{IN(MAX)} - V_{OUT})}{V_{IN(MAX)} \times L_{OUT} \times F_{SW} \times 0.8} \quad (9)$$

The RMS inductor current can be found from [Equation 10](#).

$$I_{L(RMS)} = \sqrt{I_{OUT(MAX)}^2 + \frac{1}{12} \times \left(\frac{V_{OUT} \times (V_{IN(MAX)} - V_{OUT})}{V_{IN(MAX)} \times L_{OUT} \times F_{SW} \times 0.8} \right)^2} \quad (10)$$

And the peak inductor current can be determined with [Equation 11](#).

$$I_{L(PK)} = I_{OUT(MAX)} + \frac{V_{OUT} \times (V_{IN(MAX)} - V_{OUT})}{1.6 \times V_{IN(MAX)} \times L_{OUT} \times F_{SW}} \quad (11)$$

For this design, the RMS inductor current is 3.51 A and the peak inductor current is 4.15 A. The chosen inductor is a Coilcraft MSS1038-252NX_ 2.5 μH . The inductor has a saturation current rating of 7.62 A and an RMS current rating of 6.55 A, meeting these requirements. Smaller or larger inductor values can be used depending on the amount of ripple current the designer wishes to allow so long as the other design requirements are met. Larger value inductors have lower AC current and result in lower output voltage ripple, while smaller inductor values increase ac current and output voltage ripple. In general, inductor values for use with the TPS54332 are in the range of 1 μH to 47 μH .

8.2.2.7 Capacitor Selection

The important design factors for the output capacitor are DC voltage rating, ripple current rating, and equivalent series resistance (ESR). The DC voltage and ripple current ratings cannot be exceeded. The ESR is important because along with the inductor current it determines the amount of output ripple voltage. The actual value of the output capacitor is not critical, but some practical limits do exist. Consider the relationship between the desired closed-loop crossover frequency of the design and LC corner frequency of the output filter. In general, keeping the closed-loop crossover frequency at less than 1/5 of the switching frequency is desirable. With high-switching frequencies such as the 1 MHz frequency of this design, internal circuit limitations of the TPS54332 limit the practical maximum crossover frequency to about 75 kHz. In general, the closed-loop crossover frequency must be higher than the corner frequency determined by the load impedance and the output capacitor. This limits the minimum capacitor value for the output filter to:

$$C_{O_MIN} = \frac{1}{2 \times \pi \times R_O \times f_{CO_MAX}} \quad (12)$$

Where R_O is the output load impedance (V_O/I_O) and f_{CO} is the desired crossover frequency. For a desired maximum crossover of 75 kHz the minimum value for the output capacitor is around 3.2 μF . This can not satisfy the output ripple voltage requirement. The output ripple voltage consists of two components; the voltage change due to the charge and discharge of the output filter capacitance and the voltage change due to the ripple current times the ESR of the output filter capacitor. The output ripple voltage can be estimated by:

$$V_{OPP} = I_{LPP} \times \left(\frac{(D - 0.5)}{4 \times F_{SW} \times C_O} + R_{ESR} \right) \quad (13)$$

Where C_O is the total effective output capacitance.

The maximum ESR of the output capacitor can be determined from the amount of allowable output ripple as specified in the initial design parameters. The contribution to the output ripple voltage due to ESR is the inductor ripple current times the ESR of the output filter, so the maximum specified ESR as listed in the capacitor data sheet is given by [Equation 14](#).

$$ESR_{MAX} = \frac{V_{OPPMAX}}{I_{LPP}} - \frac{(D - 0.5)}{4 \times F_{SW} \times C_O} \quad (14)$$

Where V_{OPPMAX} is the desired maximum peak-to-peak output ripple. The maximum RMS ripple current in the output capacitor is given by [Equation 15](#).

$$I_{COUT(RMS)} = \frac{1}{\sqrt{12}} \times \left(\frac{V_{OUT} \times (V_{IN(MAX)} - V_{OUT})}{V_{IN(MAX)} \times L_{OUT} \times F_{SW} \times N_C} \right) \quad (15)$$

The minimum switching frequency must be used in the above equations (derated by a factor of 0.8). For this design example, two 47- μF ceramic output capacitors are chosen for C2 and C3. These are rated at 10 V with a maximum ESR of 3 m Ω and a ripple current rating in excess of 3 A. The calculated total RMS ripple current is 300 mA (150 mA each) and the total ESR required is 20 m Ω or less. These output capacitors exceed the requirements by a wide margin and result in a reliable, high-performance design. Note that the actual capacitance in circuit can be less than the catalog value when the output is operating at the desired output of 2.5 V. 10-V rated capacitors are used to minimize the this reduction in capacitance due to dc voltage on the output. The selected output capacitor must be rated for a voltage greater than the desired output voltage plus $\frac{1}{2}$ the

ripple voltage. Any derating amount must also be included. Other capacitor types work well with the TPS54332, depending on the needs of the application.

8.2.2.8 Compensation Components

The external compensation used with the TPS54332 allows for a wide range of output filter configurations. A large range of capacitor values and types of dielectric are supported. The design example uses ceramic X5R dielectric output capacitors, but other types are supported.

TI recommends a type II compensation scheme for the TPS54332. The compensation components are chosen to set the desired closed-loop crossover frequency and phase margin for output filter components. The type II compensation has the following characteristics; a DC gain component, a low-frequency pole, and a mid-frequency zero or pole pair.

The DC gain is determined by [Equation 16](#).

$$G_{DC} = \frac{V_{GGM} \times V_{REF}}{V_O} \quad (16)$$

Where:

$$V_{GGM} = 800$$

$$V_{REF} = 0.8 \text{ V}$$

The low-frequency pole is determined by [Equation 17](#).

$$F_{P0} = \frac{1}{2 \times \pi \times R_{O0} \times C_Z} \quad (17)$$

$$R_{O0} = 8.696 \text{ M}\Omega.$$

The mid-frequency zero is determined by [Equation 18](#).

$$F_{Z1} = \frac{1}{2 \times \pi \times R_Z \times C_Z} \quad (18)$$

And, the mid-frequency pole is given by [Equation 19](#).

$$F_{P1} = \frac{1}{2 \times \pi \times R_Z \times C_P} \quad (19)$$

The first step is to choose the closed-loop crossover frequency. The closed-loop crossover frequency must be less than 1/8 of the minimum operating frequency, but for the TPS54332 TI recommends that the maximum closed-loop crossover frequency be not greater than 75 kHz. Next, the required gain and phase boost of the crossover network must be calculated. By definition, the gain of the compensation network must be the inverse of the gain of the modulator and output filter. For this design example, where the ESR zero is much higher than the closed-loop crossover frequency, the gain of the modulator and output filter can be approximated by [Equation 20](#).

$$\text{Gain} = -20 \times \log(2 \times \pi \times R_{SENSE} \times F_{CO} \times C_O) \quad (20)$$

Where:

$$R_{SENSE} = 1 \Omega / 12$$

F_{CO} = Closed-loop crossover frequency

C_O = Output capacitance

The phase loss is given by [Equation 21](#).

$$PL = \alpha \times \tan(2 \times \pi \times F_{CO} \times R_{ESR} \times C_O) - \alpha \times \tan(2 \times \pi \times F_{CO} \times R_O \times C_O) - 10\text{dB} \quad (21)$$

Where:

R_{ESR} = Equivalent series resistance of the output capacitor

$R_O = V_O/I_O$

The measured overall loop response for the circuit is given in [Figure 8-9](#). Note that the actual closed-loop crossover frequency is higher than intended at about 25 kHz. This is primarily due to variation in the actual values of the output filter components and tolerance variation of the internal feed-forward gain circuitry. Overall the design has greater than 60 degrees of phase margin and is completely stable over all combinations of line and load variability.

Now that the phase loss is known the required amount of phase boost to meet the phase margin requirement can be determined. The required phase boost is given by [Equation 22](#).

$$PB = (PM - 90\text{deg}) - PL \quad (22)$$

Where PM = the desired phase margin.

A zero, pole pair of the compensation network is placed symmetrically around the intended closed-loop frequency to provide maximum phase boost at the crossover point. The amount of separation can be determined by [Equation 23](#) and the resultant zero and pole frequencies are given by [Equation 24](#) and [Equation 25](#).

$$k = \tan\left(\frac{PB}{2} + 45\text{deg}\right) \quad (23)$$

$$F_{Z1} = \frac{F_{CO}}{k} \quad (24)$$

$$F_{P1} = F_{CO} \times k \quad (25)$$

The low-frequency pole is set so that the gain at the crossover frequency is equal to the inverse of the gain of the modulator and output filter. Due to the relationships established by the pole and zero relationships, the value of R_Z can be derived directly by [Equation 26](#).

$$R_Z = \frac{2 \times \pi \times F_{CO} \times V_O \times C_O \times R_{OA}}{GM_{COMP} \times V_{GGM} \times V_{REF}} \quad (26)$$

Where:

V_O = Output voltage

C_O = Output capacitance

F_{CO} = Desired crossover frequency

$R_{OA} = 8.696 \text{ M}\Omega$

$GM_{COMP} = 12 \text{ A/V}$

$V_{GGM} = 800$

$V_{REF} = 0.8 \text{ V}$

With R_Z known, C_Z and C_P can be calculated using [Equation 27](#) and [Equation 28](#).

$$C_Z = \frac{1}{2 \times \pi \times F_{Z1} \times R_Z} \quad (27)$$

$$C_P = \frac{1}{2 \times \pi \times F_{P1} \times R_Z} \quad (28)$$

For this design, the two 47- μF output capacitors are used. For ceramic capacitors, the actual output capacitance is less than the rated value when the capacitors have a DC bias voltage applied. This is the case in a DC/DC converter. The actual output capacitance can be as low as 54 μF . The combined ESR is approximately 0.001 Ω .

Using [Equation 20](#) and [Equation 21](#), the output stage gain and phase loss are equivalent as:

$$\text{Gain} = -6.94 \text{ dB}$$

and

$$\text{PL} = -93.94 \text{ degrees}$$

For 70 degrees of phase margin, [Equation 22](#) requires 63.64 degrees of phase boost.

[Equation 23](#), [Equation 24](#), and [Equation 25](#) are used to find the zero and pole frequencies of:

$$F_{Z1} = 11.57 \text{ kHz}$$

And

$$F_{P1} = 216 \text{ kHz}$$

R_Z , C_Z , and C_P are calculated using [Equation 26](#), [Equation 27](#), and [Equation 28](#).

$$R_Z = \frac{2 \times \pi \times 50000 \times 2.5 \times 82 \times 10^{-6} \times 8.696 \times 10^6}{12 \times 800 \times 0.8} = 72.92 \text{ k}\Omega \quad (29)$$

$$C_Z = \frac{1}{2 \times \pi \times 11570 \times 75000} = 183 \text{ pF} \quad (30)$$

$$C_P = \frac{1}{2 \times \pi \times 216000 \times 75000} = 9.8 \text{ pF} \quad (31)$$

Using standard values for R_3 , C_6 , and C_7 in the application schematic of [Figure 8-1](#).

$$R_3 = 75 \text{ k}\Omega$$

$$C_6 = 180 \text{ pF}$$

$$C_7 = 10 \text{ pF}$$

8.2.2.9 Bootstrap Capacitor

Every TPS54332 design requires a bootstrap capacitor, C_4 . The bootstrap capacitor must be 0.1 μF . The bootstrap capacitor is located between the PH pins and BOOT pin. The bootstrap capacitor must be a high-quality, ceramic type with X7R or X5R grade dielectric for temperature stability.

8.2.2.10 Catch Diode

The TPS54332 is designed to operate using an external catch diode between PH and GND. The selected diode must meet the absolute maximum ratings for the application: Reverse voltage must be higher than the maximum voltage at the PH pin, which is $V_{\text{in(max)}} + 0.5 \text{ V}$. Peak current must be greater than I_{OUTMAX} plus on half the peak-to-peak inductor current. Forward-voltage drop must be small for higher efficiencies. Make note that the catch diode conduction time is typically longer than the high-side FET on time, so attention paid to diode parameters can make a marked improvement in overall efficiency. Additionally, check that the device chosen is capable of dissipating the power losses. For this design, a Diodes, Inc. B340A is chosen, with a reverse voltage of 40 V, forward current of 3 A, and a forward voltage drop of 0.5 V.

8.2.2.11 Output Voltage Limitations

Due to the internal design of the TPS54332, there are both upper and lower output voltage limits for any given input voltage. The upper limit of the output voltage set point is constrained by the maximum duty cycle of 91% and is given by [Equation 32](#).

$$V_{O(\text{MAX})} = 0.91 \times \left((V_{\text{IN(MIN)}} - I_{O(\text{MAX})} \times R_{\text{DS(ON)MAX}}) + V_D \right) - (I_{O(\text{MAX})} \times R_L) - V_D \quad (32)$$

Where:

$V_{IN(min)}$ = Minimum input voltage

$I_{O(max)}$ = Maximum load current

V_D = Catch diode forward voltage

R_L = Output inductor series resistance

The equation assumes maximum on resistance for the internal high-side FET.

The lower limit is constrained by the minimum controllable on time which can be as high as 130 ns. The approximate minimum output voltage for a given input voltage and minimum load current is given by [Equation 33](#).

$$V_{O(MIN)} = 0.118 \times ((V_{IN(MAX)} - I_{O(MIN)} \times R_{DS(ON)MAX} + V_D) - I_{O(MIN)} \times R_L) - V_D \quad (33)$$

Where:

$V_{IN(max)}$ = Maximum input voltage

$I_{O(min)}$ = Minimum load current

V_D = Catch diode forward voltage

R_L = Output inductor series resistance

This equation assumes nominal on-resistance for the high-side FET and accounts for worst case variation of operating frequency set point. Any design operating near the operational limits of the device must be carefully checked to assure proper functionality.

8.2.2.12 Power Dissipation Estimate

The following formulas show how to estimate the device power dissipation under continuous conduction mode operations. These formulas must not be used if the device is working in the discontinuous conduction mode (DCM) or pulse-skipping Eco-mode.

The device power dissipation includes:

1. Conduction loss: $P_{con} = I_{out}^2 \times R_{DS(on)} \times V_{OUT}/V_{IN}$
2. Switching loss: $P_{sw} = 0.55 \times 10^{-9} \times V_{IN}^2 \times I_{OUT} \times F_{sw}$
3. Gate charge loss: $P_{gc} = 22.8 \times 10^{-9} \times F_{sw}$
4. Quiescent current loss: $P_q = 0.082 \times 10^{-3} \times V_{IN}$

Where:

- I_{OUT} is the output current (A).
- $R_{DS(on)}$ is the on-resistance of the high-side MOSFET (Ω).
- V_{OUT} is the output voltage (V).
- V_{IN} is the input voltage (V).
- F_{sw} is the switching frequency (Hz).
- $P_{tot} = P_{con} + P_{sw} + P_{gc} + P_q$
- For given T_A , $T_J = T_A + R_{th} \times P_{tot}$.
- For given $T_{JMAX} = 150^\circ\text{C}$, $T_{AMAX} = T_{JMAX} - R_{th} \times P_{tot}$.

Where:

- P_{tot} is the total device power dissipation (W).
- T_A is the ambient temperature ($^\circ\text{C}$).
- T_J is the junction temperature ($^\circ\text{C}$).
- R_{th} is the thermal resistance of the package ($^\circ\text{C}/\text{W}$).
- T_{JMAX} is maximum junction temperature ($^\circ\text{C}$).
- T_{AMAX} is maximum ambient temperature ($^\circ\text{C}$).

8.2.3 Application Curves

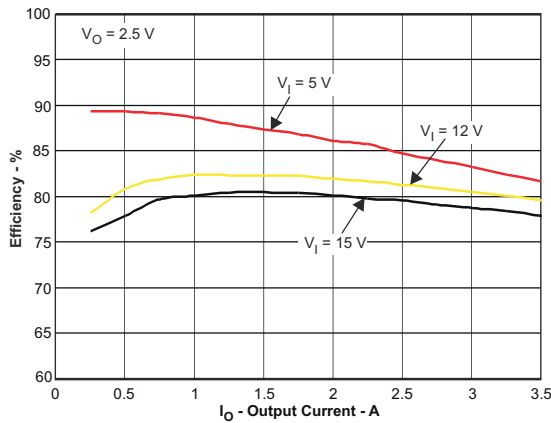

Figure 8-2. TPS54332 Efficiency

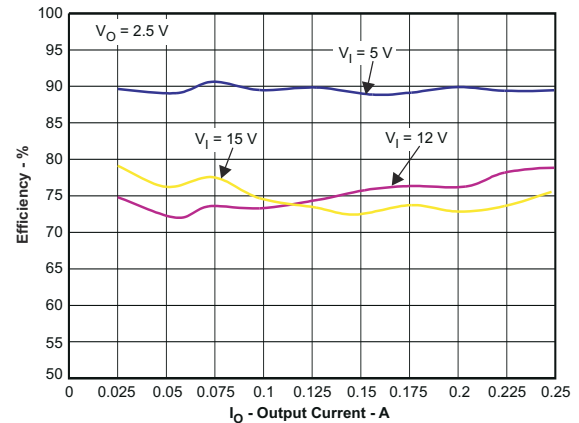

Figure 8-3. TPS54332 Low-Current Efficiency

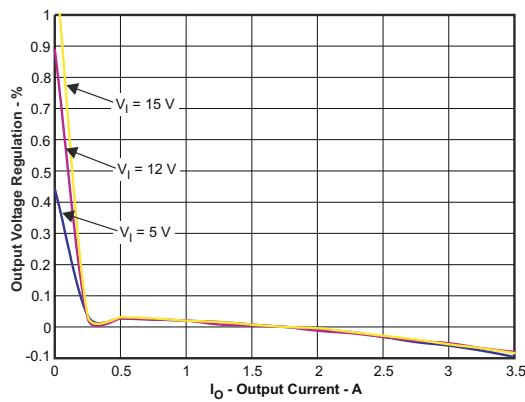

Figure 8-4. TPS54332 Load Regulation

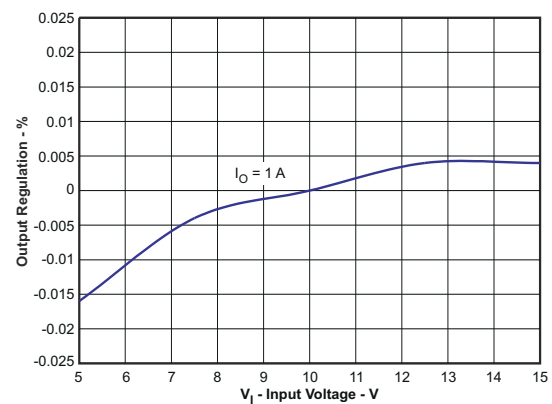

Figure 8-5. TPS54332 Line Regulation

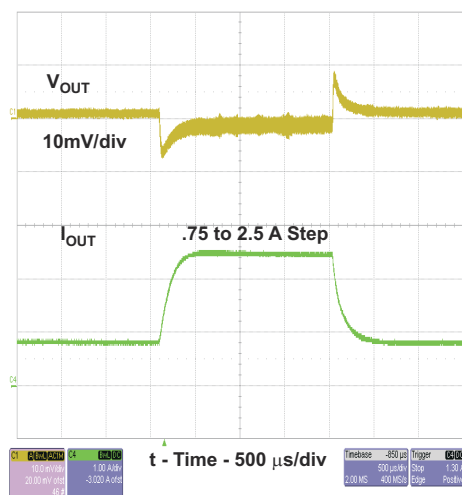

Figure 8-6. TPS54332 Transient Response

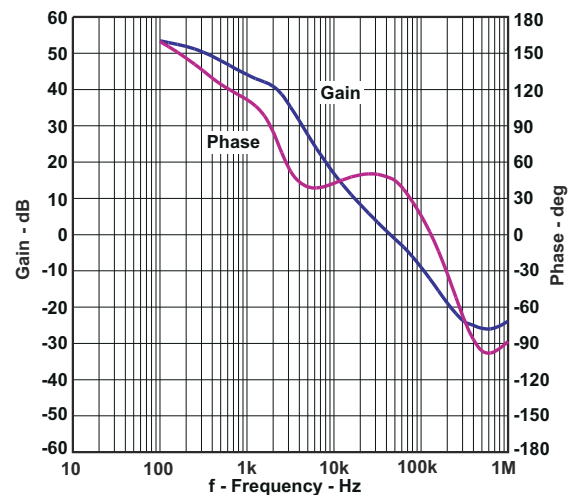

Figure 8-7. TPS54332 Loop Response

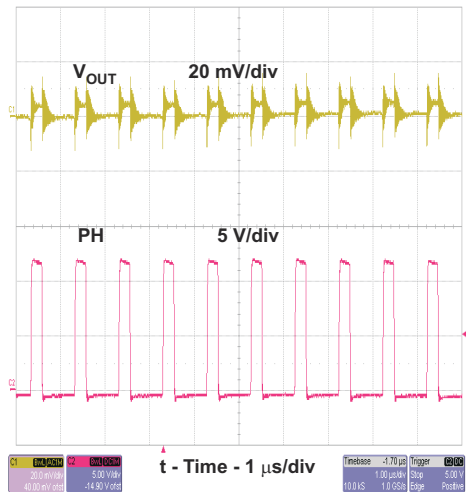

Figure 8-8. TPS54332 Output Ripple

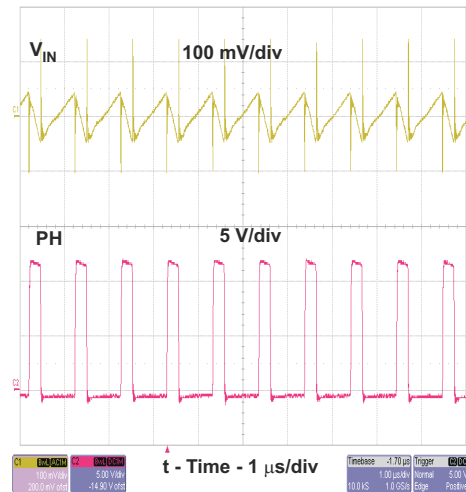

Figure 8-9. TPS54332 Input Ripple

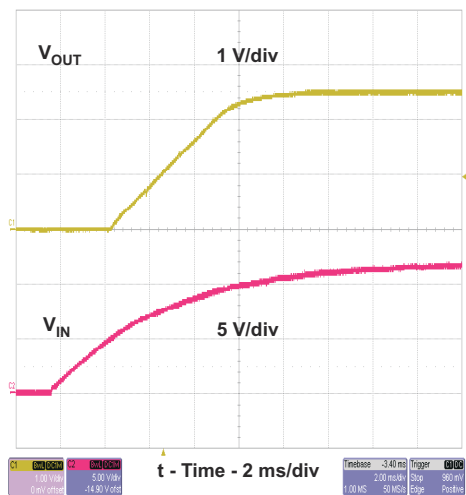

Figure 8-10. TPS54332 Start-Up

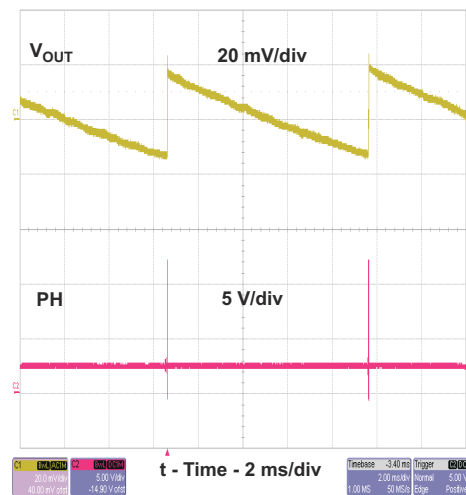

Figure 8-11. TPS54332 Output Ripple during Eco-mode Operation

8.3 Power Supply Recommendations

The devices are designed to operate from an input voltage supply range between 3.5 V and 28 V. This input supply must be well regulated. If the input supply is located more than a few inches from the converter additional bulk capacitance can be required in addition to the ceramic bypass capacitors. An electrolytic capacitor with a value of 100 μ F is a typical choice.

8.4 Layout

8.4.1 Layout Guidelines

The VIN pin must be bypassed to ground with a low-ESR, ceramic bypass capacitor. Take care to minimize the loop area formed by the bypass capacitor connections, the VIN pin, and the anode of the catch diode. The typical recommended bypass capacitance is 10- μ F ceramic with a X5R or X7R dielectric and the optimum placement is closest to the VIN pins and the source of the anode of the catch diode. See [Figure 8-12](#) for a PCB layout example. The GND D pin must be tied to the PCB ground plane at the pin of the IC. The source of the low-side MOSFET must be connected directly to the top-side PCB ground area used to tie together the ground sides of the input and output capacitors, as well as the anode of the catch diode. The PH pin must be routed to the cathode of the catch diode and to the output inductor. Because the PH connection is the switching node, the catch diode and output inductor must be located very close to the PH pins, and the area of the PCB conductor

minimized to prevent excessive capacitive coupling. For operation at full rated load, the top-side ground area must provide adequate heat dissipating area. The TPS54332 uses a fused lead frame so that the GND pin acts as a conductive path for heat dissipation from the die. Many applications have larger areas of internal or back side ground plane available, and the top-side ground area can be connected to these areas using multiple vias under or adjacent to the device to help dissipate heat. The additional external components can be placed approximately as shown. It can be possible to obtain acceptable performance with alternate layout schemes, however this layout has been shown to produce good results and is intended as a guideline.

8.4.2 Layout Example

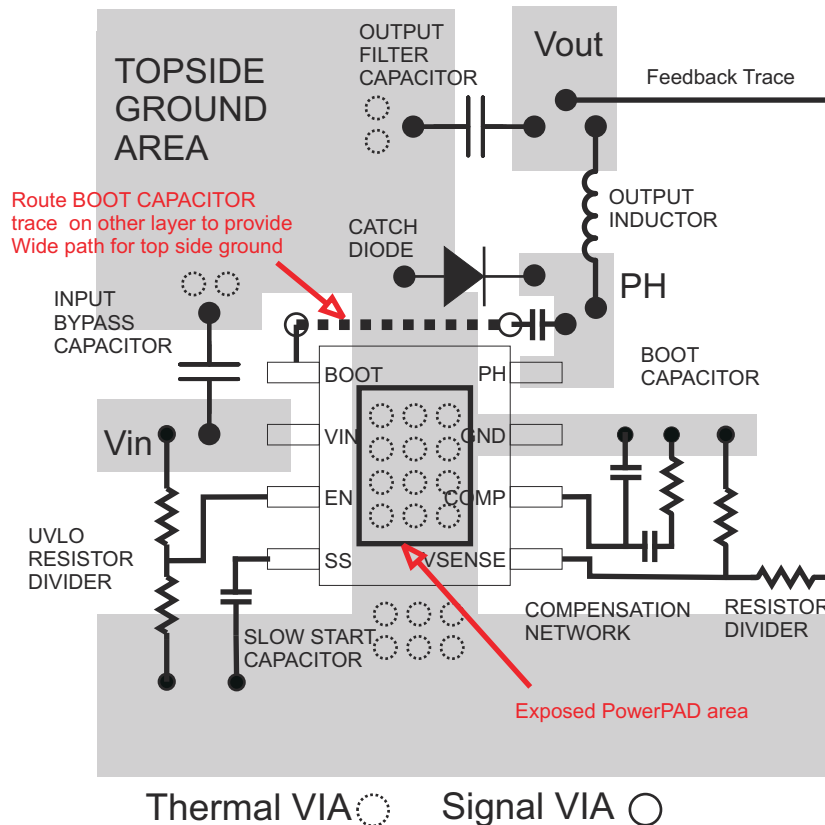

Figure 8-12. TPS54332 Board Layout

8.4.3 Estimated Circuit Area

The estimated printed circuit board area for the components used in the design of Figure 8-1 is 0.58 in². This area does not include test points or connectors.

8.4.4 Electromagnetic Interference (EMI) Considerations

As EMI becomes a rising concern in more and more applications, the internal design of the TPS54332 takes measures to reduce the EMI. The high-side MOSFET gate-drive is designed to reduce the PH pin voltage ringing. The internal IC rails are isolated to decrease the noise sensitivity. A package bond wire scheme is used to lower the parasitics effects.

To achieve the best EMI performance, external component selection and board layout are equally important. Follow the [Detailed Design Procedure](#) to prevent potential EMI issues.

9 Device and Documentation Support

9.1 Device Support

9.1.1 Development Support

9.1.1.1 Custom Design with WEBENCH® Tools

Create a custom design with the TPS54332 using the [WEBENCH® Power Designer](#)

1. Start by entering the input voltage (V_{in}), output voltage (V_{out}), and output current (I_{out}) requirements.
2. Optimize the design for key parameters such as efficiency, footprint, and cost using the optimizer dial.
3. Compare the generated design with other possible solutions from Texas Instruments.

The WEBENCH Power Designer gives a customized schematic along with a list of materials with real-time pricing and component availability.

In most cases, these actions are available:

- Run electrical simulations to see important waveforms and circuit performance
- Run thermal simulations to understand board thermal performance
- Export customized schematic and layout into popular CAD formats
- Print PDF reports for the design, and share the design with colleagues

Get more information about WEBENCH tools at www.ti.com/WEBENCH.

9.2 Support Resources

[TI E2E™ support forums](#) are an engineer's go-to source for fast, verified answers and design help — straight from the experts. Search existing answers or ask your own question to get the quick design help you need.

Linked content is provided "AS IS" by the respective contributors. They do not constitute TI specifications and do not necessarily reflect TI's views; see TI's [Terms of Use](#).

9.3 Receiving Notification of Documentation Updates

To receive notification of documentation updates, navigate to the device product folder on ti.com. Click on *Subscribe to updates* to register and receive a weekly digest of any product information that has changed. For change details, review the revision history included in any revised document.

9.4 Trademarks

PowerPAD™ and TI E2E™ are trademarks of Texas Instruments.

WEBENCH® is a registered trademark of Texas Instruments.

All trademarks are the property of their respective owners.

9.5 Electrostatic Discharge Caution



This integrated circuit can be damaged by ESD. Texas Instruments recommends that all integrated circuits be handled with appropriate precautions. Failure to observe proper handling and installation procedures can cause damage.

ESD damage can range from subtle performance degradation to complete device failure. Precision integrated circuits may be more susceptible to damage because very small parametric changes could cause the device not to meet its published specifications.

9.6 Glossary

[TI Glossary](#) This glossary lists and explains terms, acronyms, and definitions.

10 Mechanical, Packaging, and Orderable Information

The following pages include mechanical, packaging, and orderable information. This information is the most current data available for the designated devices. This data is subject to change without notice and revision of this document. For browser-based versions of this data sheet, refer to the left-hand navigation.

PACKAGING INFORMATION

Orderable Device	Status (1)	Package Type	Package Drawing	Pins	Package Qty	Eco Plan (2)	Lead finish/ Ball material (6)	MSL Peak Temp (3)	Op Temp (°C)	Device Marking (4/5)	Samples
TPS54332DDA	ACTIVE	SO PowerPAD	DDA	8	75	RoHS & Green	NIPDAU	Level-2-260C-1 YEAR	-40 to 150	54332	Samples
TPS54332DDAR	ACTIVE	SO PowerPAD	DDA	8	2500	RoHS & Green	NIPDAU	Level-2-260C-1 YEAR	-40 to 150	54332	Samples

(1) The marketing status values are defined as follows:

ACTIVE: Product device recommended for new designs.

LIFEBUY: TI has announced that the device will be discontinued, and a lifetime-buy period is in effect.

NRND: Not recommended for new designs. Device is in production to support existing customers, but TI does not recommend using this part in a new design.

PREVIEW: Device has been announced but is not in production. Samples may or may not be available.

OBSOLETE: TI has discontinued the production of the device.

(2) **RoHS:** TI defines "RoHS" to mean semiconductor products that are compliant with the current EU RoHS requirements for all 10 RoHS substances, including the requirement that RoHS substance do not exceed 0.1% by weight in homogeneous materials. Where designed to be soldered at high temperatures, "RoHS" products are suitable for use in specified lead-free processes. TI may reference these types of products as "Pb-Free".

RoHS Exempt: TI defines "RoHS Exempt" to mean products that contain lead but are compliant with EU RoHS pursuant to a specific EU RoHS exemption.

Green: TI defines "Green" to mean the content of Chlorine (Cl) and Bromine (Br) based flame retardants meet JS709B low halogen requirements of <=1000ppm threshold. Antimony trioxide based flame retardants must also meet the <=1000ppm threshold requirement.

(3) MSL, Peak Temp. - The Moisture Sensitivity Level rating according to the JEDEC industry standard classifications, and peak solder temperature.

(4) There may be additional marking, which relates to the logo, the lot trace code information, or the environmental category on the device.

(5) Multiple Device Markings will be inside parentheses. Only one Device Marking contained in parentheses and separated by a "~" will appear on a device. If a line is indented then it is a continuation of the previous line and the two combined represent the entire Device Marking for that device.

(6) Lead finish/Ball material - Orderable Devices may have multiple material finish options. Finish options are separated by a vertical ruled line. Lead finish/Ball material values may wrap to two lines if the finish value exceeds the maximum column width.

Important Information and Disclaimer:The information provided on this page represents TI's knowledge and belief as of the date that it is provided. TI bases its knowledge and belief on information provided by third parties, and makes no representation or warranty as to the accuracy of such information. Efforts are underway to better integrate information from third parties. TI has taken and continues to take reasonable steps to provide representative and accurate information but may not have conducted destructive testing or chemical analysis on incoming materials and chemicals. TI and TI suppliers consider certain information to be proprietary, and thus CAS numbers and other limited information may not be available for release.

In no event shall TI's liability arising out of such information exceed the total purchase price of the TI part(s) at issue in this document sold by TI to Customer on an annual basis.

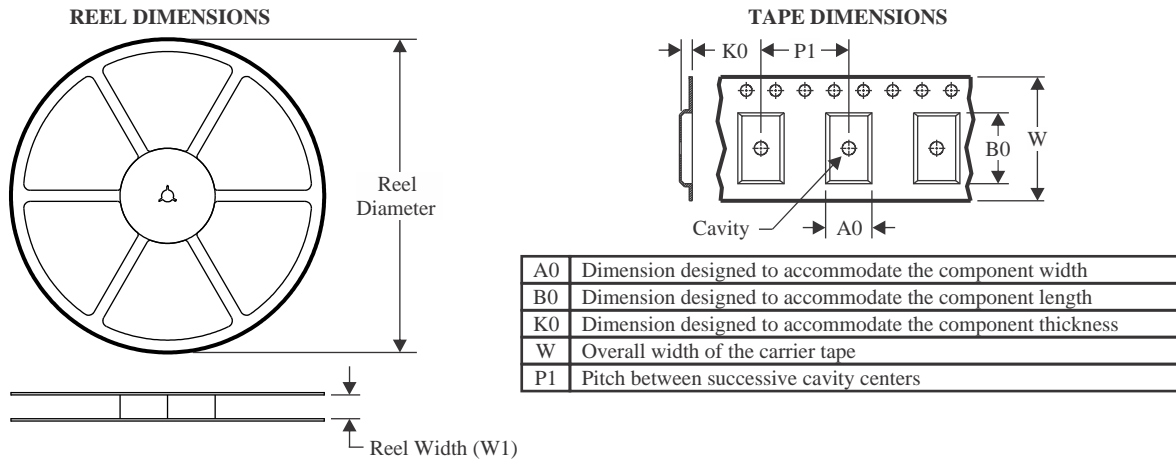
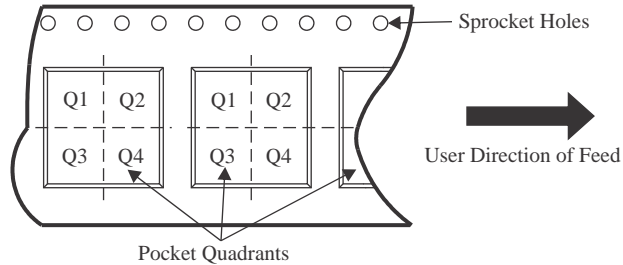
TAPE AND REEL INFORMATION

QUADRANT ASSIGNMENTS FOR PIN 1 ORIENTATION IN TAPE

*All dimensions are nominal

Device	Package Type	Package Drawing	Pins	SPQ	Reel Diameter (mm)	Reel Width W1 (mm)	A0 (mm)	B0 (mm)	K0 (mm)	P1 (mm)	W (mm)	Pin1 Quadrant
TPS54332DDAR	SO PowerPAD	DDA	8	2500	330.0	12.4	6.4	5.2	2.1	8.0	12.0	Q1

TAPE AND REEL BOX DIMENSIONS

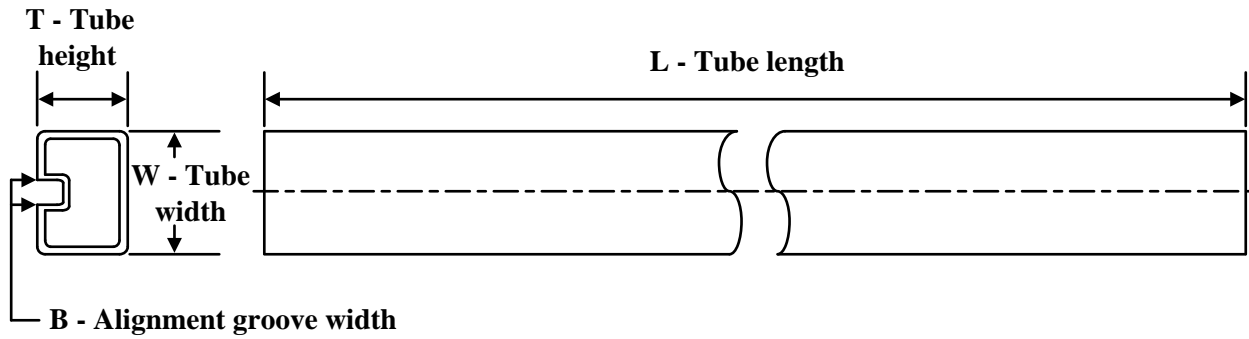

*All dimensions are nominal

Device	Package Type	Package Drawing	Pins	SPQ	Length (mm)	Width (mm)	Height (mm)
TPS54332DDAR	SO PowerPAD	DDA	8	2500	356.0	356.0	35.0

TUBE

*All dimensions are nominal

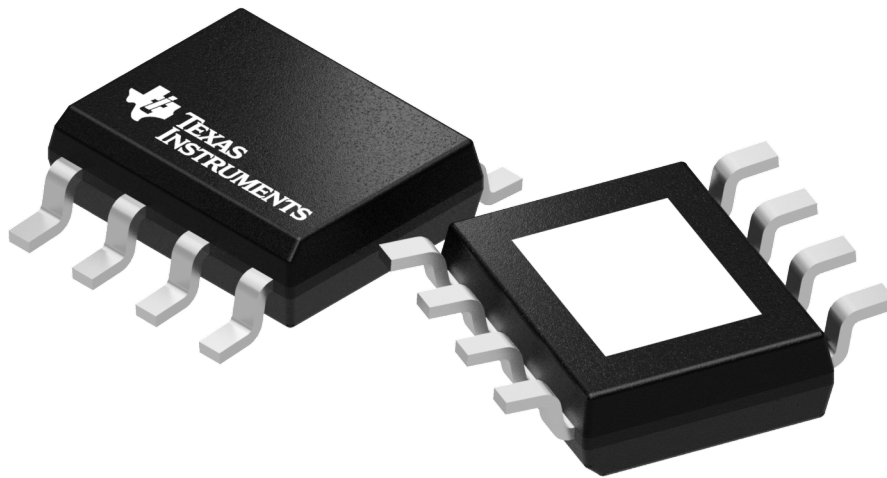
Device	Package Name	Package Type	Pins	SPQ	L (mm)	W (mm)	T (μm)	B (mm)
TPS54332DDA	DDA	HSOIC	8	75	506.6	8	3940	4.32



Images above are just a representation of the package family, actual package may vary.
Refer to the product data sheet for package details.

DDA (R-PDSO-G8)

PowerPAD™ PLASTIC SMALL-OUTLINE

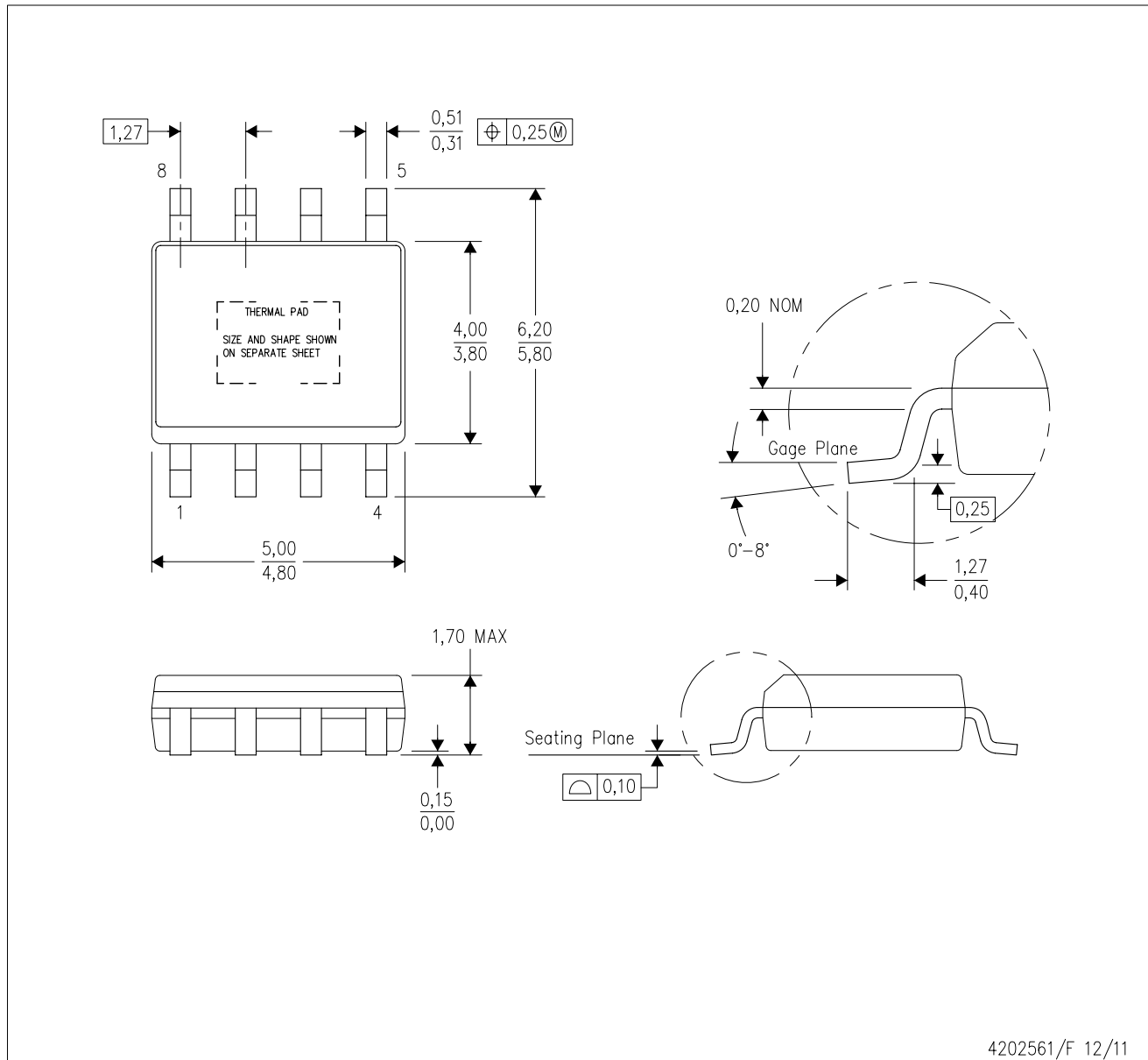

4202561/F 12/11

- NOTES:
- All linear dimensions are in millimeters. Dimensioning and tolerancing per ASME Y14.5-1994.
 - This drawing is subject to change without notice.
 - Body dimensions do not include mold flash or protrusion not to exceed 0,15.
 - This package is designed to be soldered to a thermal pad on the board. Refer to Technical Brief, PowerPad Thermally Enhanced Package, Texas Instruments Literature No. SLMA002 for information regarding recommended board layout. This document is available at www.ti.com <<http://www.ti.com>>.
 - See the additional figure in the Product Data Sheet for details regarding the exposed thermal pad features and dimensions.
 - This package complies to JEDEC MS-012 variation BA

PowerPAD is a trademark of Texas Instruments.

DDA (R-PDSO-G8)

PowerPAD™ PLASTIC SMALL OUTLINE

THERMAL INFORMATION

This PowerPAD™ package incorporates an exposed thermal pad that is designed to be attached to a printed circuit board (PCB). The thermal pad must be soldered directly to the PCB. After soldering, the PCB can be used as a heatsink. In addition, through the use of thermal vias, the thermal pad can be attached directly to the appropriate copper plane shown in the electrical schematic for the device, or alternatively, can be attached to a special heatsink structure designed into the PCB. This design optimizes the heat transfer from the integrated circuit (IC).

For additional information on the PowerPAD package and how to take advantage of its heat dissipating abilities, refer to Technical Brief, PowerPAD Thermally Enhanced Package, Texas Instruments Literature No. SLMA002 and Application Brief, PowerPAD Made Easy, Texas Instruments Literature No. SLMA004. Both documents are available at www.ti.com.

The exposed thermal pad dimensions for this package are shown in the following illustration.

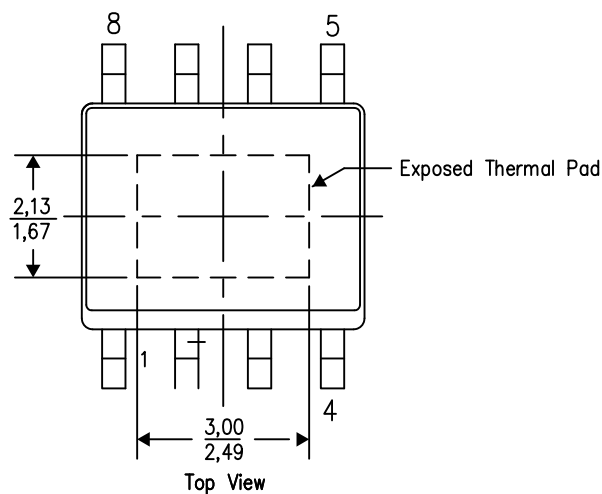

Exposed Thermal Pad Dimensions

4206322-5/L 05/12

NOTE: A. All linear dimensions are in millimeters

PowerPAD is a trademark of Texas Instruments

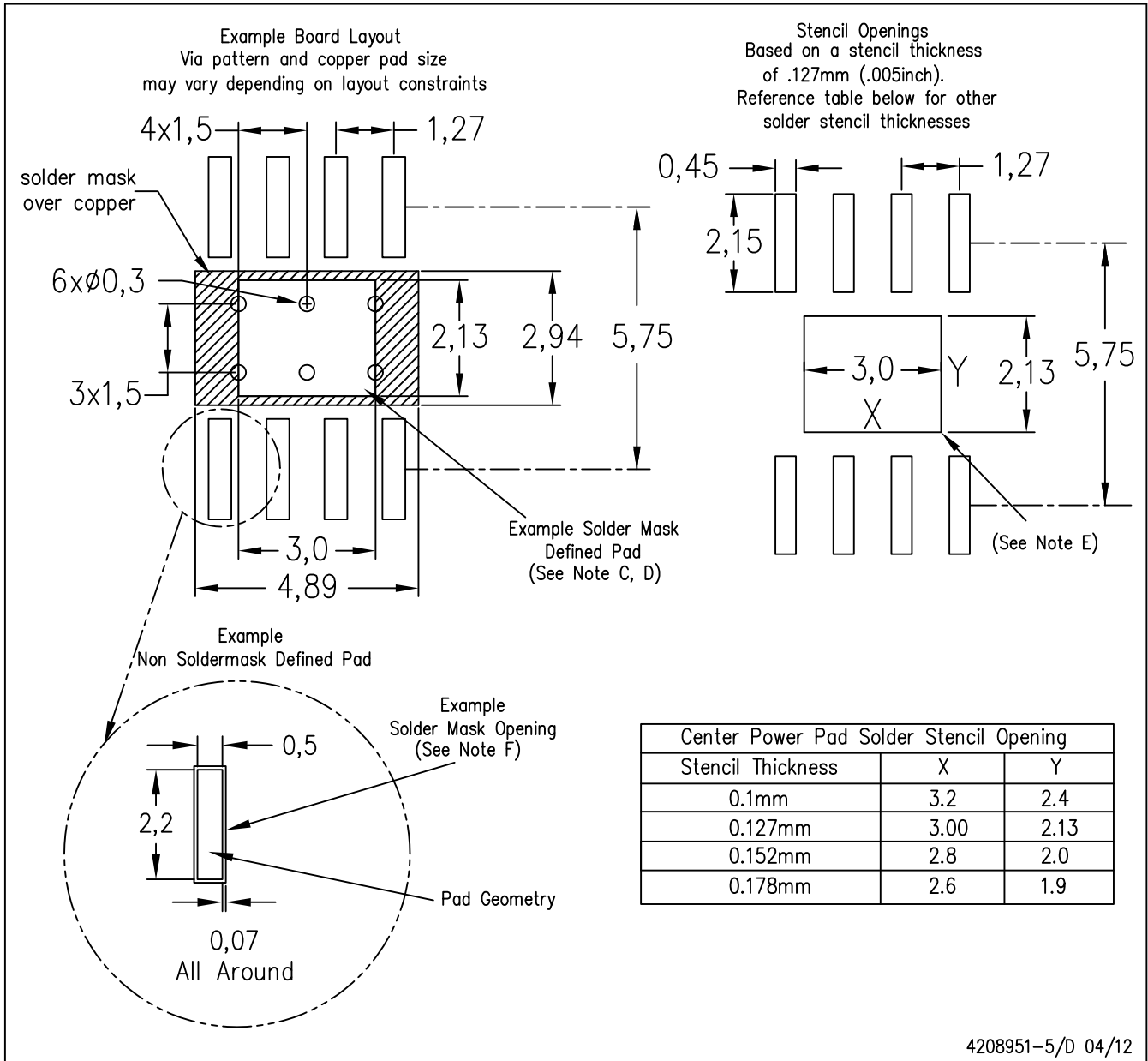

- NOTES:
- A. All linear dimensions are in millimeters.
 - B. This drawing is subject to change without notice.
 - C. Customers should place a note on the circuit board fabrication drawing not to alter the center solder mask defined pad.
 - D. This package is designed to be soldered to a thermal pad on the board. Refer to Technical Brief, PowerPad Thermally Enhanced Package, Texas Instruments Literature No. SLMA002, SLMA004, and also the Product Data Sheets for specific thermal information, via requirements, and recommended board layout. These documents are available at www.ti.com <<http://www.ti.com>>. Publication IPC-7351 is recommended for alternate designs.
 - E. Laser cutting apertures with trapezoidal walls and also rounding corners will offer better paste release. Customers should contact their board assembly site for stencil design recommendations. Example stencil design based on a 50% volumetric metal load solder paste. Refer to IPC-7525 for other stencil recommendations.
 - F. Customers should contact their board fabrication site for solder mask tolerances between and around signal pads.

PowerPAD is a trademark of Texas Instruments.

IMPORTANT NOTICE AND DISCLAIMER

TI PROVIDES TECHNICAL AND RELIABILITY DATA (INCLUDING DATA SHEETS), DESIGN RESOURCES (INCLUDING REFERENCE DESIGNS), APPLICATION OR OTHER DESIGN ADVICE, WEB TOOLS, SAFETY INFORMATION, AND OTHER RESOURCES "AS IS" AND WITH ALL FAULTS, AND DISCLAIMS ALL WARRANTIES, EXPRESS AND IMPLIED, INCLUDING WITHOUT LIMITATION ANY IMPLIED WARRANTIES OF MERCHANTABILITY, FITNESS FOR A PARTICULAR PURPOSE OR NON-INFRINGEMENT OF THIRD PARTY INTELLECTUAL PROPERTY RIGHTS.

These resources are intended for skilled developers designing with TI products. You are solely responsible for (1) selecting the appropriate TI products for your application, (2) designing, validating and testing your application, and (3) ensuring your application meets applicable standards, and any other safety, security, regulatory or other requirements.

These resources are subject to change without notice. TI grants you permission to use these resources only for development of an application that uses the TI products described in the resource. Other reproduction and display of these resources is prohibited. No license is granted to any other TI intellectual property right or to any third party intellectual property right. TI disclaims responsibility for, and you will fully indemnify TI and its representatives against, any claims, damages, costs, losses, and liabilities arising out of your use of these resources.

TI's products are provided subject to [TI's Terms of Sale](#) or other applicable terms available either on [ti.com](https://www.ti.com) or provided in conjunction with such TI products. TI's provision of these resources does not expand or otherwise alter TI's applicable warranties or warranty disclaimers for TI products.

TI objects to and rejects any additional or different terms you may have proposed.

Mailing Address: Texas Instruments, Post Office Box 655303, Dallas, Texas 75265
Copyright © 2023, Texas Instruments Incorporated

Looking for pricing, stock, or lifecycle information?

Click below to explore more details on WIN SOURCE:

 [View TPS54332DDAR](#) on WIN SOURCE

 [Texas Instruments](#) Information

Optimize Your Supply Chain with WIN SOURCE Solutions

-  Global Sourcing Solution
-  Obsolete Management
-  Cost Control Management
-  Shortage Management
-  Alternative Solution
-  Excess Inventory Management