



**THE DATASHEET OF
TPS54521RHLR**



4.5V to 17V Input, 5A Synchronous Step Down Converter

Check for Samples: [TPS54521](#)

FEATURES

- Integrated 57mΩ / 50mΩ MOSFETs
- Split Power Rail: 1.6V to 17V on PVIN
- 200kHz to 900kHz Switching Frequency
- Synchronizes to External Clock
- 0.8V Voltage Reference
- Low 2uA Shutdown Quiescent Current
- Hiccup Overcurrent Protection
- Monotonic Start-Up into Prebiased Outputs
- –40°C to 125°C Operating Junction Temperature Range
- Pin-to-Pin Compatible with the TPS54620
- Adjustable Slow Start/Power Sequencing

- Power Good Output for Undervoltage and Overvoltage Monitoring
- Adjustable Input Undervoltage Lockout
- Supported by SwitcherPro™ Software Tool

APPLICATIONS

- Flat Panel Digital TVs
- Set Top Boxes, Personal Video Recorders
- Net Books
- High Density 3.3V/5V Power Distribution from 12 V Bus

DESCRIPTION

The TPS54521 is a full featured 17V, 5A synchronous step down converter which is optimized for small designs through high efficiency and integrated high-side and low-side MOSFETs. Further space savings are achieved through current mode control, which reduces component count, and by selecting a high switching frequency, reducing the inductor's footprint.

The output voltage startup ramp is controlled by the SS/TR pin which allows operation as either a stand alone power supply or in tracking situations. Power sequencing is also possible by correctly configuring the enable and the open drain power good pins.

Cycle by cycle current limiting on the high-side FET protects the device in overload situations and is enhanced by a low-side sourcing current limit which prevents current runaway. Hiccup protection will be triggered if the overcurrent condition has persisted for longer than the preset time. Thermal shutdown disables the part when die temperature exceeds thermal shutdown temperature. The TPS54521 is available in a 14 pin, 3.5mm x 3.5mm QFN, thermally enhanced package.

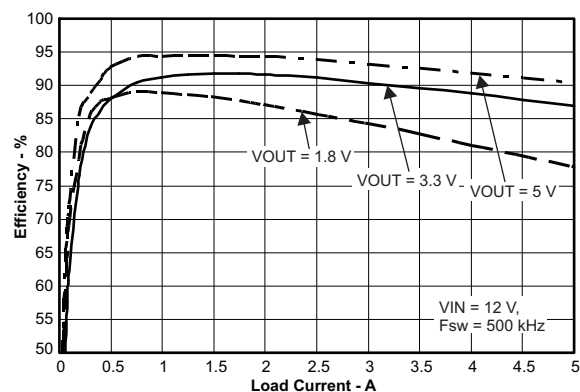
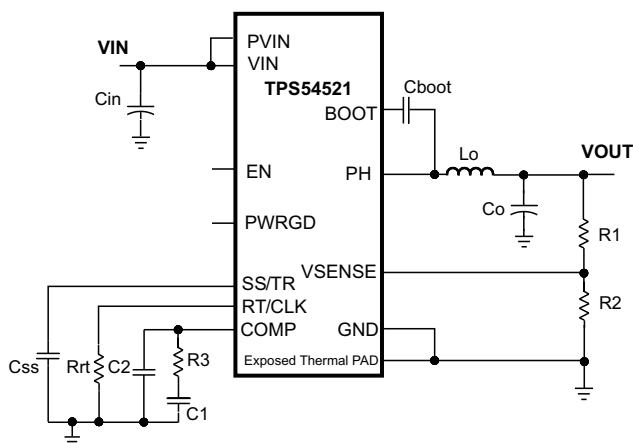
SIMPLIFIED SCHEMATIC

Please be aware that an important notice concerning availability, standard warranty, and use in critical applications of Texas Instruments semiconductor products and disclaimers thereto appears at the end of this data sheet.

SwitcherPro is a trademark of Texas Instruments.

PRODUCTION DATA information is current as of publication date. Products conform to specifications per the terms of the Texas Instruments standard warranty. Production processing does not necessarily include testing of all parameters.

Copyright © 2010–2013, Texas Instruments Incorporated



These devices have limited built-in ESD protection. The leads should be shorted together or the device placed in conductive foam during storage or handling to prevent electrostatic damage to the MOS gates.

ORDERING INFORMATION⁽¹⁾

T _J	PACKAGE	PART NUMBER ⁽²⁾
–40°C to 125°C	14 Pin QFN	TPS54521RHL

- (1) For the most current package and ordering information, see the Package Option Addendum at the end of this document, or see the TI web site at www.ti.com.
- (2) The RHL package is also available taped and reeled. Add an R suffix to the device type (i.e., TPS54521RHRL). See applications section of data sheet for layout information.

ABSOLUTE MAXIMUM RATINGS⁽¹⁾

over operating temperature range (unless otherwise noted)		VALUE	UNIT
Input Voltage	V _{IN}	–0.3 to 20	V
	P _{VIN}	–0.3 to 20	V
	EN	–0.3 to 6	V
	BOOT	–0.3 to 28	V
	V _{SENSE}	–0.3 to 3	V
	COMP	–0.3 to 3	V
	P _{WRGD}	–0.3 to 6	V
	SS/TR	–0.3 to 3	V
	RT/CLK	–0.3 to 6	V
Output Voltage	BOOT-PH	0 to 8	V
	PH	–1 to 20	V
	PH 10ns Transient	–3 to 20	V
V _{diff} (GND to exposed thermal pad)		–0.2 to 0.2	V
Source Current	RT/CLK	±100	µA
	PH	Current Limit	A
Sink Current	PH	Current Limit	A
	P _{VIN}	Current Limit	A
	COMP	±200	µA
	P _{WRGD}	–0.1 to 5	mA
	Electrostatic Discharge (HBM) QSS 009-105 (JESD22-A114A)		2
Electrostatic Discharge (CDM) QSS 009-147 (JESD22-C101B.01)		500	V
Operating Junction Temperature		–40 to 125	°C
Storage Temperature		–65 to 150	°C

- (1) Stresses beyond those listed under absolute maximum ratings may cause permanent damage to the device. These are stress ratings only, and functional operation of the device at these or any other conditions beyond those indicated under recommended operating conditions is not implied. Exposure to absolute-maximum-rated conditions for extended periods may affect device reliability.

THERMAL INFORMATION

THERMAL METRIC ⁽¹⁾⁽²⁾		TPS54521	UNITS
		QFN	
		14 PINS	
θ_{JA}		47.2	°C/W
θ_{JA}	Junction-to-ambient thermal resistance ⁽³⁾	32	
θ_{JCTop}	Junction-to-case (top) thermal resistance	64.8	
θ_{JB}	Junction-to-board thermal resistance	14.4	
Ψ_{JT}	Junction-to-top characterization parameter	0.5	
Ψ_{JB}	Junction-to-board characterization parameter	14.7	
θ_{JCbott}	Junction-to-case (bottom) thermal resistance	3.2	

- (1) For more information about traditional and new thermal metrics, see the IC Package Thermal Metrics application report, [SPRA953](#).
- (2) Power rating at a specific ambient temperature T_A should be determined with a junction temperature of 125°C. This is the point where distortion starts to substantially increase. Thermal management of the PCB should strive to keep the junction temperature at or below 125°C for best performance and long-term reliability. See power dissipation estimate in application section of this data sheet for more information.
- (3) Test board conditions:
- 2.5 inches x 2.5 inches, 4 layers, thickness: 0.062 inch
 - 2 oz. copper traces located on the top of the PCB
 - 2 oz. copper ground planes on the 2 internal layers and bottom layer
 - 4 0.010 inch thermal vias located under the device package

ELECTRICAL CHARACTERISTICS
 $T_J = -40^{\circ}\text{C}$ to 125°C , $V_{IN} = 4.5\text{V}$ to 17V , $PV_{IN} = 1.6\text{V}$ to 17V (unless otherwise noted)

DESCRIPTION	CONDITIONS	MIN	TYP	MAX	UNIT
SUPPLY VOLTAGE (VIN AND PVIN PINS)					
PVIN operating input voltage		1.6		17	V
VIN operating input voltage		4.5		17	V
VIN internal UVLO threshold	VIN rising		4.0	4.5	V
VIN internal UVLO hysteresis			150		mV
VIN shutdown supply Current	EN = 0 V		2	5	μA
VIN operating – non switching supply current	VSENSE = 810 mV		600	800	μA
ENABLE AND UVLO (EN PIN)					
Enable threshold	Rising		1.21	1.26	V
Enable threshold	Falling	1.10	1.17		V
Input current	EN = 1.1 V		1.15		μA
Hysteresis current	EN = 1.3 V		3.4		μA
VOLTAGE REFERENCE					
Voltage reference	$0\text{ A} \leq I_{\text{out}} \leq 5\text{ A}$	0.776	0.800	0.824	V
MOSFET					
High-side switch resistance ⁽¹⁾	BOOT-PH = 3 V		74	105	m Ω
High-side switch resistance ⁽¹⁾	BOOT-PH = 6 V		57	95	m Ω
Low-side Switch Resistance ⁽¹⁾	VIN = 12 V		50	82	m Ω
ERROR AMPLIFIER					
Error amplifier Transconductance (gm)	$-2\ \mu\text{A} < I_{\text{COMP}} < 2\ \mu\text{A}$, $V_{(\text{COMP})} = 1\text{ V}$		1300		μMhos
Error amplifier dc gain	VSENSE = 0.8 V	1000	3100		V/V
Error amplifier source/sink	$V_{(\text{COMP})} = 1\text{ V}$, 100 mV input overdrive		± 110		μA
Start switching threshold			0.25		V
COMP to Iswitch gm			12		A/V
CURRENT LIMIT					
High-side switch current limit threshold		7	9		A
Low-side switch sourcing current limit		6	8		A
Low-side switch sinking current limit		1	2.6		A
Hiccup wait time before triggering hiccup			512		cycles
Hiccup time before restart			16384		cycles

(1) Measured at pins

ELECTRICAL CHARACTERISTICS (continued)
 $T_J = -40^{\circ}\text{C}$ to 125°C , $V_{IN} = 4.5\text{V}$ to 17V , $P_{VIN} = 1.6\text{V}$ to 17V (unless otherwise noted)

DESCRIPTION	CONDITIONS	MIN	TYP	MAX	UNIT
THERMAL SHUTDOWN					
Thermal shutdown		140	150		$^{\circ}\text{C}$
Thermal shutdown hysteresis			5		$^{\circ}\text{C}$
TIMING RESISTOR AND EXTERNAL CLOCK (RT/CLK PIN)					
Minimum switching frequency	$R_{rt} = 240\text{ k}\Omega$ (1%)	160	200	240	kHz
Switching frequency	$R_{rt} = 100\text{ k}\Omega$ (1%)	400	480	560	kHz
Maximum switching frequency	$R_{rt} = 53\text{ k}\Omega$ (1%)	765	900	1035	kHz
Minimum pulse width			20		ns
RT/CLK high threshold				2	V
RT/CLK low threshold		0.8			V
RT/CLK falling edge to PH rising edge delay	Measure at 500 kHz with RT resistor in series		62		ns
Switching frequency range (RT mode set point and PLL mode)		200		900	kHz
PH (PH PIN)					
Minimum on time	Measured at 90% to 90% of PH, $T_A = 25^{\circ}\text{C}$, $I_{PH} = 2\text{A}$		97	135	ns
Minimum off time	$\text{BOOT-PH} \geq 3\text{ V}$		0		ns
BOOT (BOOT PIN)					
BOOT-PH UVLO			2.1	3	V
SLOW START AND TRACKING (SS/TR PIN)					
SS charge current			2.3		μA
SS/TR to VSENSE matching	$V_{(SS/TR)} = 0.4\text{ V}$		29	60	mV
POWER GOOD (PWRGD PIN)					
VSENSE threshold	VSENSE falling (Fault)		91		% Vref
	VSENSE rising (Good)		94		% Vref
	VSENSE rising (Fault)		109		% Vref
	VSENSE falling (Good)		106		% Vref
Output high leakage	$V_{\text{SENSE}} = V_{\text{ref}}$, $V_{(\text{PWRGD})} = 5.5\text{ V}$		30	100	nA
Output low	$I_{(\text{PWRGD})} = 2\text{ mA}$			0.3	V
Minimum V_{IN} for valid output	$V_{(\text{PWRGD})} < 0.5\text{V}$ at $100\text{ }\mu\text{A}$		0.6	1	V
Minimum SS/TR voltage for PWRGD valid			1.2	1.4	V

DEVICE INFORMATION

PIN ASSIGNMENTS

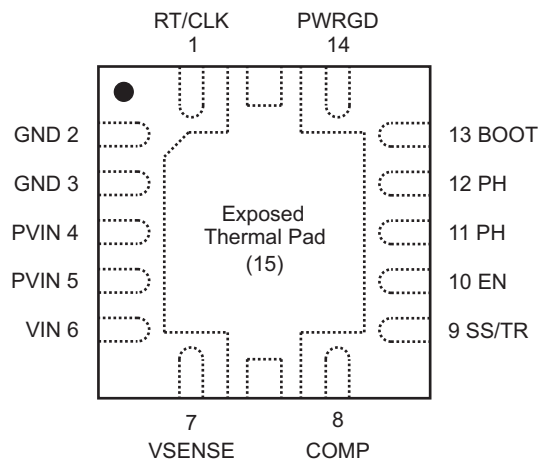

PIN FUNCTIONS

PIN		DESCRIPTION
NAME	No.	
RT/CLK	1	Automatically selects between RT mode and CLK mode. An external timing resistor adjusts the switching frequency of the device; In CLK mode, the device synchronizes to an external clock.
GND	2, 3	Return for control circuitry and low-side power MOSFET.
PVIN	4, 5	Power input. Supplies the power switches of the power converter.
VIN	6	Supplies the control circuitry of the power converter.
VSENSE	7	Inverting input of the gm error amplifier.
COMP	8	Error amplifier output, and input to the output switch current comparator. Connect frequency compensation to this pin.
SS/TR	9	Slow-start and tracking. An external capacitor connected to this pin sets the internal voltage reference rise time. The voltage on this pin overrides the internal reference. It can be used for tracking and sequencing.
EN	10	Enable pin. Float to enable. Adjust the input undervoltage lockout with two resistors.
PH	11, 12	The switch node.
BOOT	13	A bootstrap cap is required between BOOT and PH. The voltage on this cap carries the gate drive voltage for the high-side MOSFET.
PWRGD	14	Open drain Power Good fault pin. Asserts low due to thermal shutdown, under-voltage, over-voltage, EN shutdown, or during slow start.
Exposed Thermal PAD	15	Thermal pad of the package and signal ground. It must be soldered down for proper operation.

FUNCTIONAL BLOCK DIAGRAM

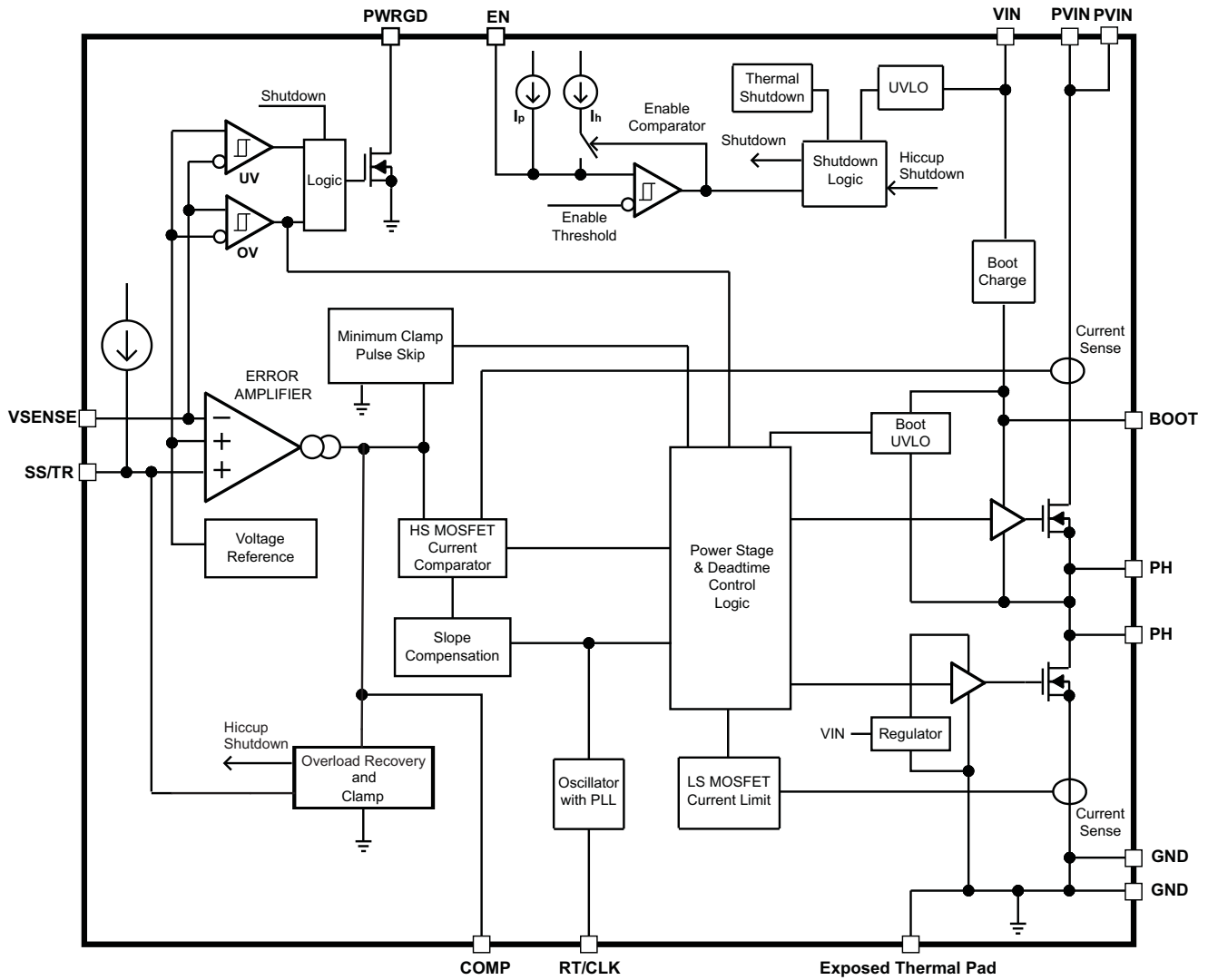

TYPICAL CHARACTERISTICS

CHARACTERISTIC CURVES

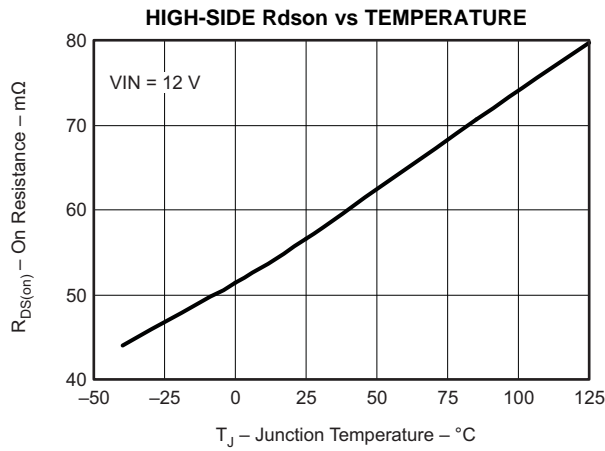

Figure 1.

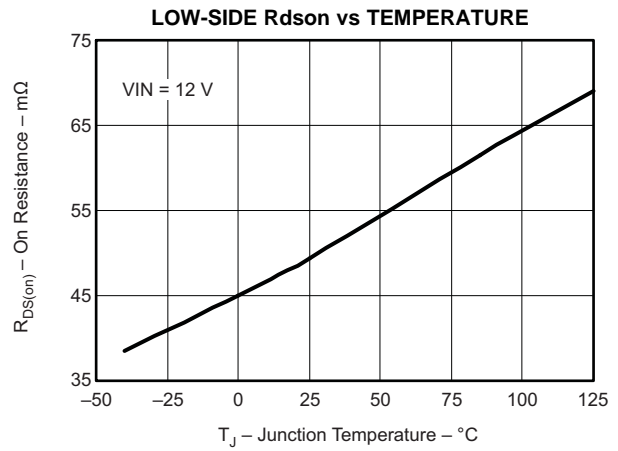

Figure 2.

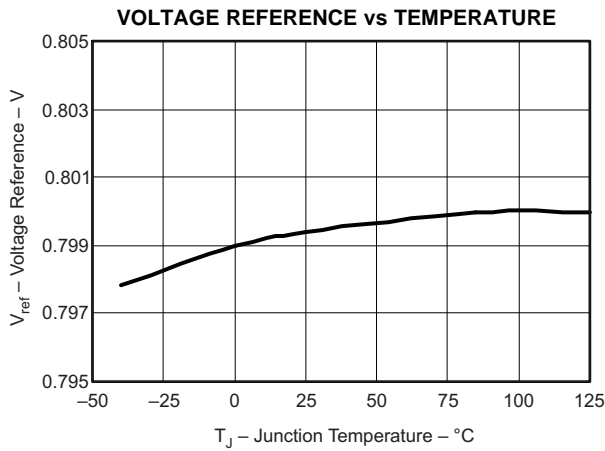

Figure 3.

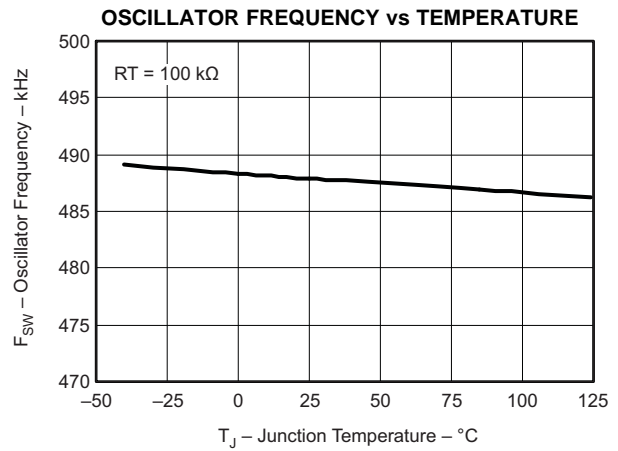

Figure 4.

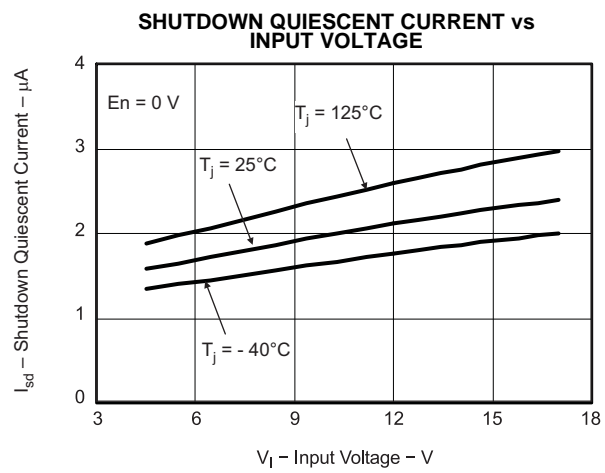

Figure 5.

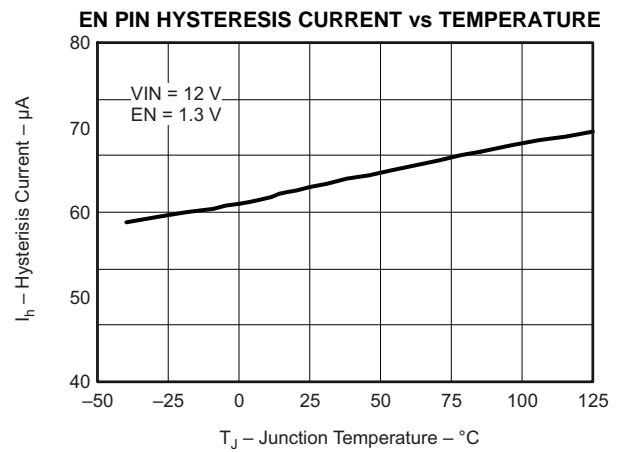

Figure 6.

TYPICAL CHARACTERISTICS (continued)

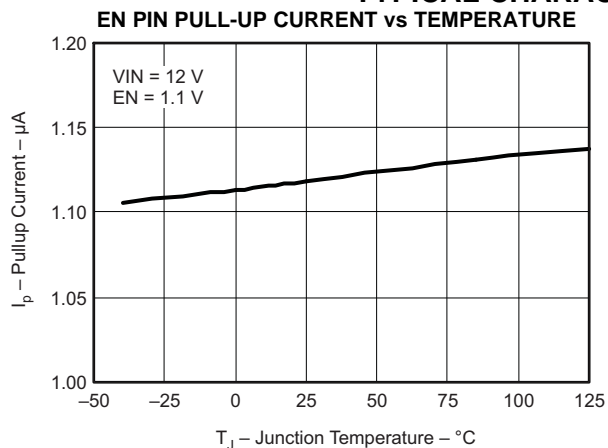

Figure 7.

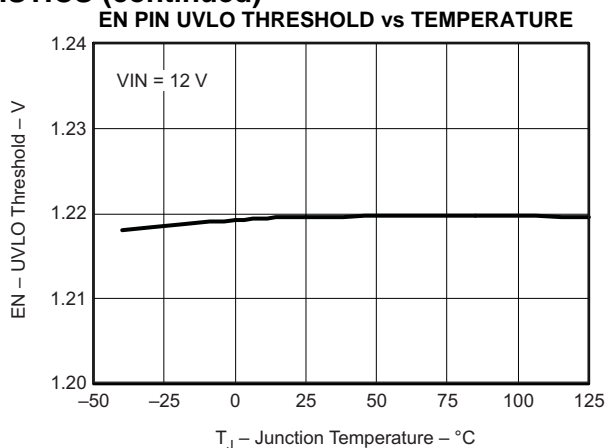

Figure 8.

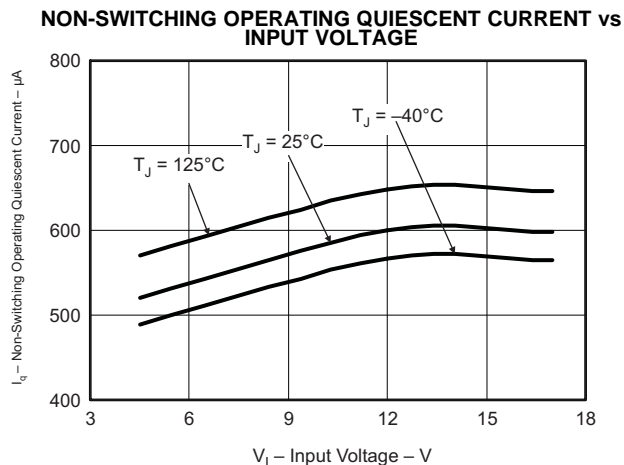

Figure 9.

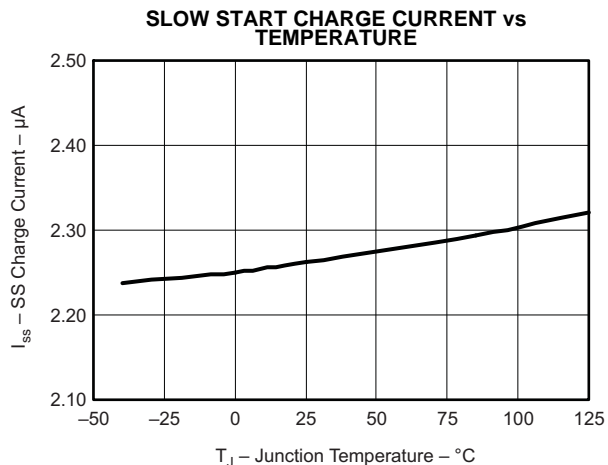

Figure 10.

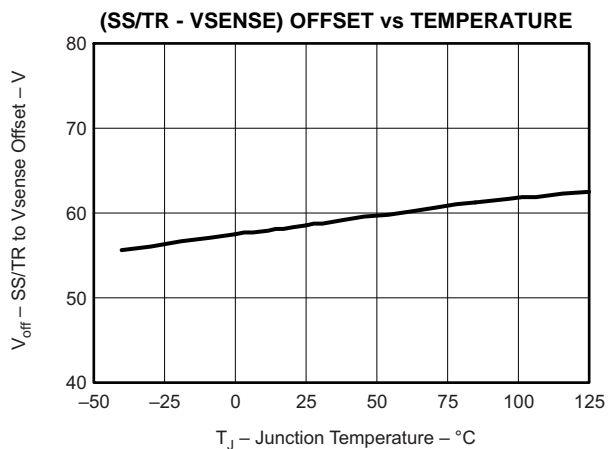

Figure 11.

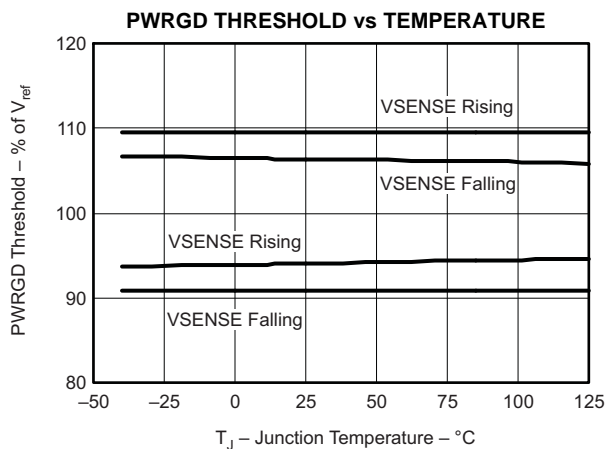
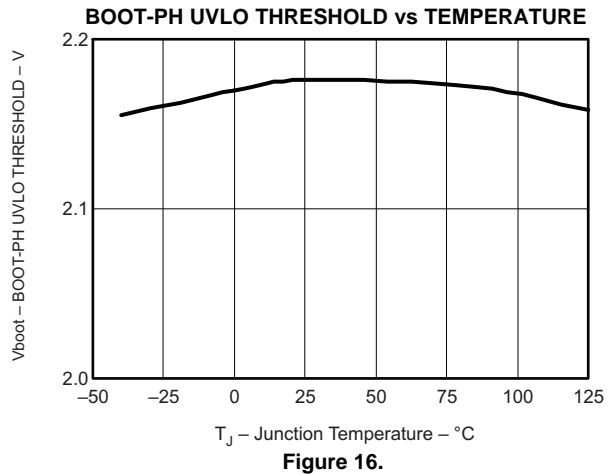
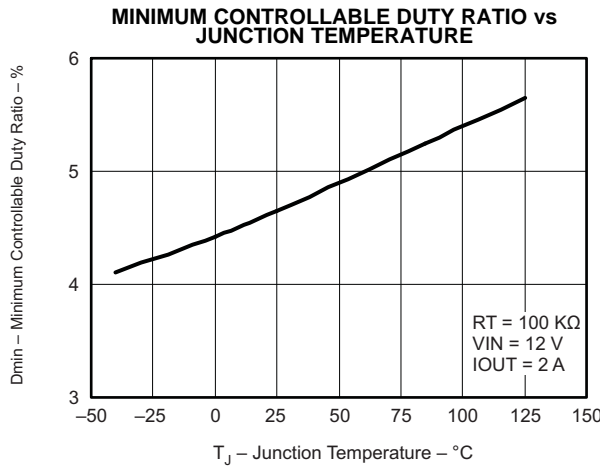
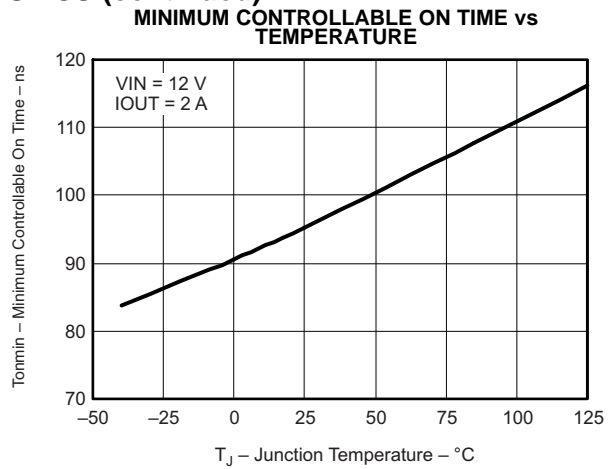
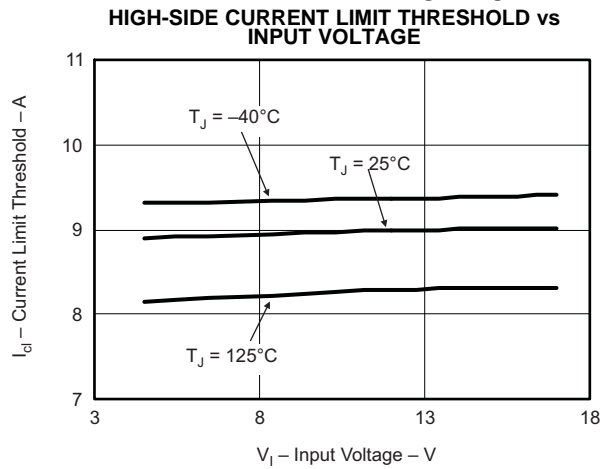

Figure 12.

TYPICAL CHARACTERISTICS (continued)



OVERVIEW

The device is a 17-V, 5-A, synchronous step-down (buck) converter with two integrated n-channel MOSFETs. To improve performance during line and load transients the device implements a constant frequency, peak current mode control which also simplifies external frequency compensation. The wide switching frequency of 200 kHz to 900 kHz allows for efficiency and size optimization when selecting the output filter components. The switching frequency is adjusted using a resistor to ground on the RT/CLK pin. The device also has an internal phase lock loop (PLL) controlled by the RT/CLK pin that can be used to synchronize the switching cycle to the falling edge of an external system clock.

The device has been designed for safe monotonic startup into pre-biased loads. The default start up is when VIN is typically 4.0V. The EN pin has an internal pull-up current source that can be used to adjust the input voltage under voltage lockout (UVLO) with two external resistors. In addition, the EN pin can be left floating for the device to automatically start with the internal pull-up current. The total operating current for the device is approximately 600µA when not switching and under no load. When the device is disabled, the supply current is typically less than 2µA.

The integrated MOSFETs allow for high efficiency power supply designs with continuous output currents up to 5 amperes. The MOSFETs have been sized to optimize efficiency for lower duty cycle applications.

TYPICAL CHARACTERISTICS (continued)

The device reduces the external component count by integrating the boot recharge circuit. The bias voltage for the integrated high-side MOSFET is supplied by a capacitor between the BOOT and PH pins. The boot capacitor voltage is monitored by a BOOT to PH UVLO (BOOT-PH UVLO) circuit allowing PH pin to be pulled low to recharge the boot capacitor. The device can operate at 100% duty cycle, as long as the boot capacitor voltage is higher than the preset BOOT-PH UVLO threshold, which is typically 2.1V. The output voltage can be stepped down to as low as the 0.8V voltage reference (Vref).

The device has a power good comparator (PWRGD) with hysteresis which monitors the output voltage through the VSENSE pin. The PWRGD pin is an open drain MOSFET which is pulled low when the VSENSE pin voltage is less than 91% or greater than 109% of the reference voltage Vref and floats high when the VSENSE pin voltage is 94% to 106% of the Vref.

The SS/TR (slow start/tracking) pin is used to minimize inrush currents or provide power supply sequencing during power up. A small value capacitor or resistor divider should be attached to the pin for slow start or critical power supply sequencing requirements.

The device is protected from output overvoltage, overload and thermal fault conditions. The device minimizes excessive output overvoltage transients by taking advantage of the overvoltage circuit power good comparator. When the overvoltage comparator is activated, the high-side MOSFET is turned off and prevented from turning on until the VSENSE pin voltage is lower than 106% of the Vref. The device implements both high-side MOSFET overload protection and bidirectional low-side MOSFET overload protections which help control the inductor current and avoid current runaway. If the overcurrent condition has lasted for more than the hiccup wait time, the device will shut down and restart after the hiccup time. The device also shuts down if the junction temperature is higher than thermal shutdown trip point. The device is restarted under control of the slow start circuit automatically when the junction temperature drops 5°C typically below the thermal shutdown trip point.

DETAILED DESCRIPTION

Fixed Frequency PWM Control

The device uses adjustable, fixed frequency, peak current mode control. The output voltage is compared through external resistors on the VSENSE pin to an internal voltage reference by an error amplifier which drives the COMP pin. An internal oscillator initiates the turn on of the high-side power switch. The error amplifier output is converted into a current reference which is compared to the high-side power switch current. When the power switch current reaches the current reference generated by the COMP voltage level, the high-side power switch is turned off and the low-side power switch is turned on.

Continuous Current Mode Operation (CCM)

As a synchronous buck converter, the device normally works in CCM (Continuous Conduction Mode) under all load conditions.

VIN and Power VIN Pins (VIN and PVIN)

The device allows for a variety of applications by using the VIN and PVIN pins together or separately. The VIN pin voltage supplies the internal control circuits of the device. The PVIN pin voltage provides the input voltage to the power converter system.

If tied together, the input voltage for VIN and PVIN can range from 4.5V to 17V. If using the VIN separately from PVIN, the VIN pin must be between 4.5V and 17V, and the PVIN pin can range from as low as 1.6V to 17V. A voltage divider connected to the EN pin can adjust either input voltage UVLO appropriately. Adjusting the input voltage UVLO on the PVIN pin helps to provide consistent power up behavior.

Voltage Reference

The voltage reference system produces a precise voltage reference by scaling the output of a temperature stable bandgap circuit.

Adjusting the Output Voltage

The output voltage is set with a resistor divider from the output (VOUT) to the VSENSE pin. It is recommended to use 1% tolerance or better divider resistors. Referring to the application schematic of [Figure 34](#), start with a 10 kΩ resistor for R9 and use [Equation 1](#) to calculate R8. To improve efficiency at light loads, consider using larger value resistors. If the values are too high, the regulator is more susceptible to noise and voltage errors from the VSENSE input current are noticeable.

$$R8 = \frac{V_{out} - V_{ref}}{V_{ref}} R9 \quad (1)$$

Where $V_{ref} = 0.8V$

The minimum output voltage and maximum output voltage can be limited by the minimum on time of the high-side MOSFET and bootstrap voltage (BOOT-PH voltage) respectively. More discussions are located in [Minimum Output Voltage](#) and [Bootstrap Voltage \(BOOT\) and Low Dropout Operation](#).

Safe Start-up into Pre-Biased Outputs

The device has been designed to prevent the low-side MOSFET from discharging a prebiased output. During monotonic pre-biased startup, the low-side MOSFET is not allowed to turn on until the SS/TR pin voltage is higher than the VSENSE pin voltage.

Error Amplifier

The device uses a transconductance error amplifier. The error amplifier compares the VSENSE pin voltage to the lower of the SS/TR pin voltage or the internal 0.8V voltage reference. The transconductance of the error amplifier is 1300 μA/V during normal operation. The frequency compensation network is connected between the COMP pin and ground.

Slope Compensation

The device adds a compensating ramp to the switch current signal. This slope compensation prevents sub-harmonic oscillations. The available peak inductor current remains constant over the full duty cycle range.

Enable and Adjusting Under-Voltage Lockout

The EN pin provides an electrical on/off control of the device. Once the EN pin voltage exceeds the threshold voltage, the device starts operation. If the EN pin voltage is pulled below the threshold voltage, the regulator stops switching and enters a low Iq state.

The EN pin has an internal pull-up current source, allowing the user to float the EN pin for enabling the device. If an application requires controlling the EN pin, use an open drain or open collector output logic to interface with the pin.

The device implements internal UVLO circuitry on the VIN pin. The device is disabled when the VIN pin voltage falls below the internal VIN UVLO threshold. The internal VIN UVLO threshold has a hysteresis of 150mV.

If an application requires either a higher UVLO threshold on the VIN pin or a secondary UVLO on the PVIN pin, in split rail applications, then the EN pin can be configured as shown in [Figure 17](#), [Figure 18](#) or [Figure 19](#). When using the external UVLO function, it is recommended to set the hysteresis to be greater than 500mV.

The EN pin has a small pull-up current I_p which sets the default state of the pin to enable when no external components are connected. The pull-up current is also used to control the voltage hysteresis for the UVLO function since it increases by I_h once the EN pin crosses the enable threshold. The UVLO thresholds can be calculated using [Equation 2](#) and [Equation 3](#).

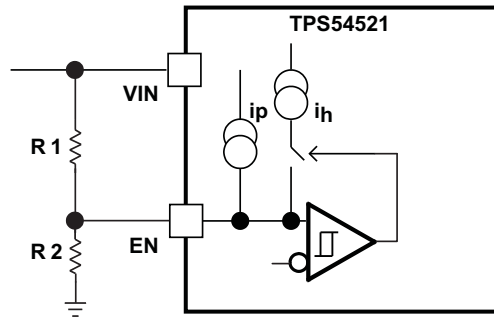

Figure 17. Adjustable VIN Under Voltage Lock Out

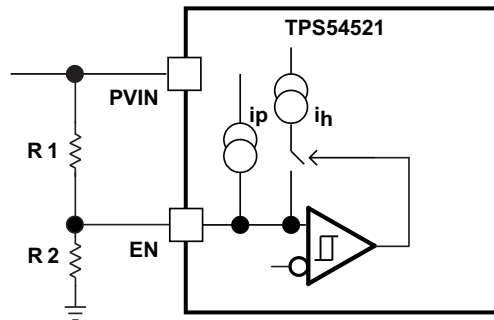

Figure 18. Adjustable PVIN Under Voltage Lock Out, VIN ≥ 4.5V

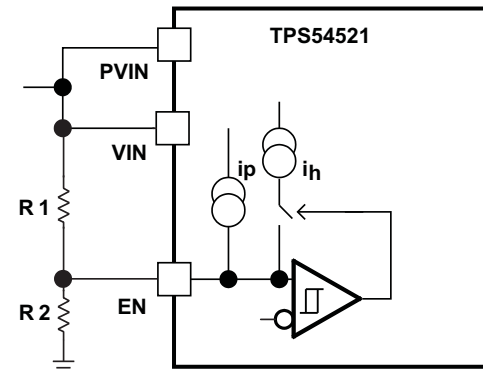

Figure 19. Adjustable VIN and PVIN Under Voltage Lock Out

$$R1 = \frac{V_{START} \left(\frac{V_{ENFALLING}}{V_{ENRISING}} \right) - V_{STOP}}{I_p \left(1 - \frac{V_{ENFALLING}}{V_{ENRISING}} \right) + I_h} \quad (2)$$

$$R2 = \frac{R1 \times V_{ENFALLING}}{V_{STOP} - V_{ENFALLING} + R1(I_p + I_h)} \quad (3)$$

Where $I_h = 3.4 \mu\text{A}$, $I_p = 1.15 \mu\text{A}$, $V_{ENRISING} = 1.21 \text{ V}$, $V_{ENFALLING} = 1.17 \text{ V}$

Adjustable Switching Frequency and Synchronization (RT/CLK)

The RT/CLK pin can be used to set the switching frequency of the device in two modes.

In RT mode, a resistor (RT resistor) is connected between the RT/CLK pin and GND. The switching frequency of the device is adjustable from 200 kHz to 900 kHz by using a maximum of 240 kΩ and minimum of 53 kΩ respectively. In CLK mode, an external clock is connected directly to the RT/CLK pin. The device is synchronized to the external clock frequency with a PLL.

The CLK mode overrides the RT mode. The device is able to detect the proper mode automatically and switch from the RT mode to CLK mode.

Adjustable Switching Frequency (RT Mode)

To determine the RT resistance for a given switching frequency, use Equation 4 or the curve in Figure 20. To reduce the solution size, one would set the switching frequency as high as possible, but tradeoffs of the supply efficiency and minimum controllable on time should be considered.

$$R_{rt}(k\Omega) = 60728 \cdot F_{sw}(kHz)^{-1.033} \tag{4}$$

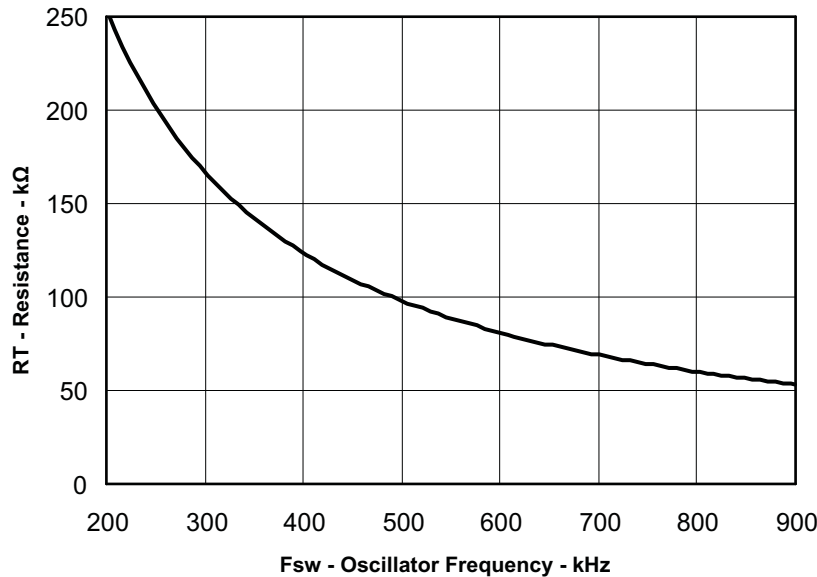

Figure 20. RT Set Resistor vs Switching Frequency

Synchronization (CLK mode)

An internal Phase Locked Loop (PLL) has been implemented to allow synchronization between 200kHz and 900kHz, and to easily switch from RT mode to CLK mode.

To implement the synchronization feature, connect a square wave clock signal to the RT/CLK pin with a duty cycle between 20% to 80%. The clock signal amplitude must transition lower than 0.8V and higher than 2.0V. The start of the switching cycle is synchronized to the falling edge of RT/CLK pin.

In applications where both RT mode and CLK mode are needed, the device can be configured as shown in Figure 21. Before the external clock is present, the device works in RT mode and the switching frequency is set by RT resistor. When the external clock is present, the CLK mode overrides the RT mode. The first time the SYNC pin is pulled above the RT/CLK high threshold (2.0V), the device switches from the RT mode to the CLK mode and the RT/CLK pin becomes high impedance as the PLL starts to lock onto the frequency of the external clock. It is not recommended to switch from the CLK mode back to the RT mode, because the internal switching frequency drops to 100kHz first before returning to the switching frequency set by RT resistor.

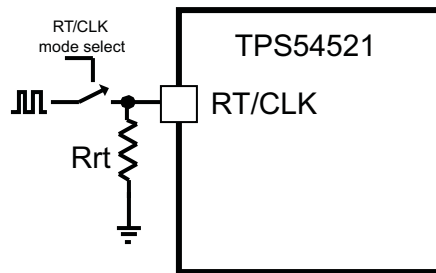

Figure 21. Works with Both RT mode and CLK mode

Slow Start (SS/TR)

The device uses the lower voltage of the internal voltage reference or the SS/TR pin voltage as the reference voltage and regulates the output accordingly. A capacitor on the SS/TR pin to ground implements a slow start time. The device has an internal pull-up current source of 2.3µA that charges the external slow start capacitor. The calculations for the slow start time (T_{ss} , 10% to 90%) and slow start capacitor (C_{ss}) are shown in Equation 5. The voltage reference (V_{ref}) is 0.8 V and the slow start charge current (I_{ss}) is 2.3µA.

$$T_{ss}(ms) = \frac{C_{ss}(nF) \times V_{ref}(V)}{I_{ss}(\mu A)} \quad (5)$$

When the input UVLO is triggered, the EN pin is pulled below 1.21V, or a thermal shutdown event occurs the device stops switching and enters low current operation. At the subsequent power up, when the shutdown condition is removed, the device does not start switching until it has discharged its SS/TR pin to ground ensuring proper soft start behavior.

Power Good (PWRGD)

The PWRGD pin is an open drain output. Once the VSENSE pin is between 94% and 106% of the internal voltage reference the PWRGD pin pull-down is de-asserted and the pin floats. It is recommended to use a pull-up resistor between the values of 10kΩ and 100kΩ to a voltage source that is 5.5V or less. The PWRGD is in a defined state once the VIN input voltage is greater than 1V but with reduced current sinking capability. The PWRGD achieves full current sinking capability once the VIN input voltage is above 4.5V.

The PWRGD pin is pulled low when VSENSE is lower than 91% or greater than 109% of the nominal internal reference voltage. Also, the PWRGD is pulled low, if the input UVLO or thermal shutdown are asserted, the EN pin is pulled low, or the SS/TR pin is below 1.2V typically.

Bootstrap Voltage (BOOT) and Low Dropout Operation

The device has an integrated boot regulator, and requires a small ceramic capacitor between the BOOT and PH pins to provide the gate drive voltage for the high-side MOSFET. The boot capacitor is charged when the BOOT pin voltage is less than VIN and BOOT-PH voltage is below regulation. The value of this ceramic capacitor should be 0.1µF. A ceramic capacitor with an X7R or X5R grade dielectric with a voltage rating of 10V or higher is recommended because of the stable characteristics over temperature and voltage.

To improve dropout, the device is designed to operate at 100% duty cycle as long as the BOOT to PH pin voltage is greater than the BOOT-PH UVLO threshold which is typically 2.1V. When the voltage between BOOT and PH drops below the BOOT-PH UVLO threshold the high-side MOSFET is turned off and the low-side MOSFET is turned on allowing the boot capacitor to be recharged. In applications with split input voltage rails 100% duty cycle operation can be achieved as long as $(V_{IN} - P_{VIN}) > 4V$.

A boot resistor in series with the boot capacitor should never be used on the TPS54521.

Sequencing (SS/TR)

Many of the common power supply sequencing methods can be implemented using the SS/TR, EN, and PWRGD pins.

TPS54521

SLVS981C – JUNE 2010 – REVISED AUGUST 2013

www.ti.com

The sequential method is illustrated in [Figure 22](#) using two TPS54521 devices. The power good of the first device is coupled to the EN pin of the second device which enables the second power supply once the primary supply reaches regulation. [Figure 23](#) shows the results of [Figure 22](#).

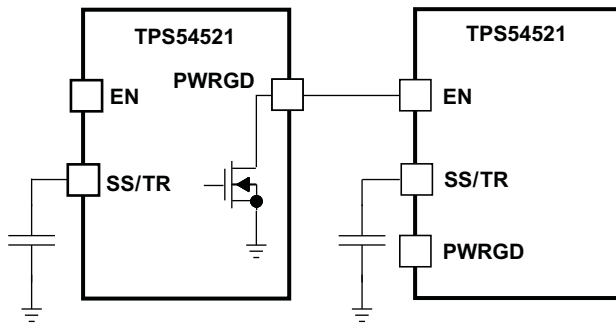

Figure 22. Sequential Start Up Sequence

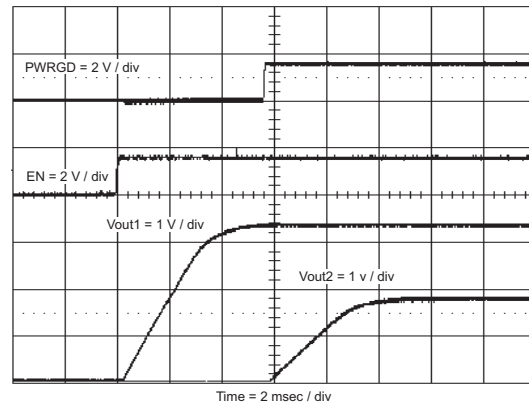

Figure 23. Sequential Start Up using EN and PWRGD

[Figure 24](#) shows the method implementing ratio-metric sequencing by connecting the SS/TR pins of two devices together. The regulator outputs ramp up and reach regulation at the same time. When calculating the slow start time the pull-up current source must be doubled in [Equation 5](#). [Figure 25](#) shows the results of [Figure 24](#).

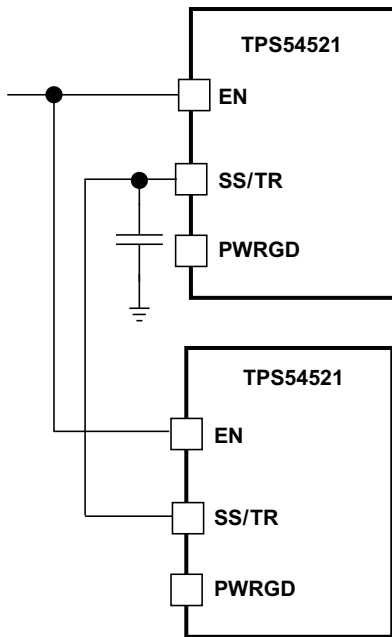

Figure 24. Ratiometric Start Up Sequence

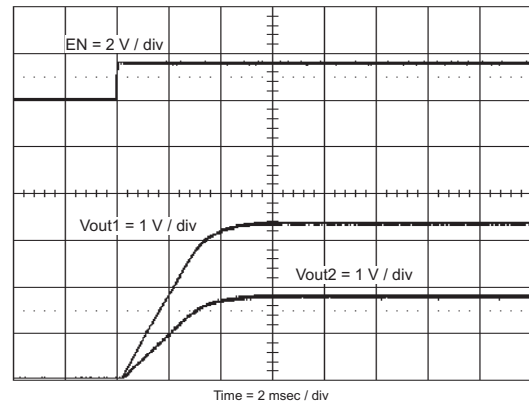

Figure 25. Ratio-metric Startup using Coupled SS/TR Pins

Ratio-metric and simultaneous power supply sequencing can be implemented by connecting the resistor network of R1 and R2 shown in [Figure 26](#) to the output of the power supply that needs to be tracked or another voltage reference source. Using [Equation 6](#) and [Equation 7](#), the tracking resistors can be calculated to initiate the Vout2 slightly before, after or at the same time as Vout1. [Equation 8](#) is the voltage difference between Vout1 and Vout2.

To design a ratio-metric start up in which the Vout2 voltage is slightly greater than the Vout1 voltage when Vout2 reaches regulation, use a negative number in [Equation 6](#) and [Equation 7](#) for deltaV. [Equation 8](#) results in a positive number for applications where the Vout2 is slightly lower than Vout1 when Vout2 regulation is achieved. [Figure 27](#) and [Figure 28](#) show the results for positive deltaV and negative deltaV respectively.

The ΔV variable is zero volts for simultaneous sequencing. To minimize the effect of the inherent SS/TR to VSENSE offset ($V_{ssoffset}$, 29mV) in the slow start circuit and the offset created by the pull-up current source (I_{ss} , 2.3 μ A) and tracking resistors, the $V_{ssoffset}$ and I_{ss} are included as variables in the equations. Figure 29 shows the result when $\Delta V = 0V$.

To ensure proper operation of the device, the calculated R1 value from Equation 6 must be greater than the value calculated in Equation 9.

$$R1 = \frac{V_{out2} + \Delta V}{V_{ref}} \times \frac{V_{ssoffset}}{I_{ss}} \tag{6}$$

$$R2 = \frac{V_{ref} \times R1}{V_{out2} + \Delta V - V_{ref}} \tag{7}$$

$$\Delta V = V_{out1} - V_{out2} \tag{8}$$

$$R1 > 2800 \times V_{out1} - 180 \times \Delta V \tag{9}$$

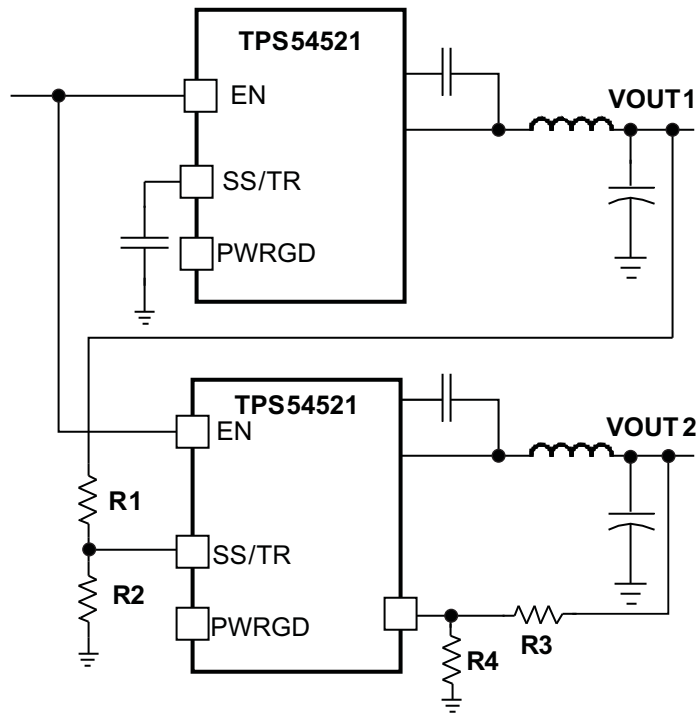

Figure 26. Ratiometric and Simultaneous Startup Sequence

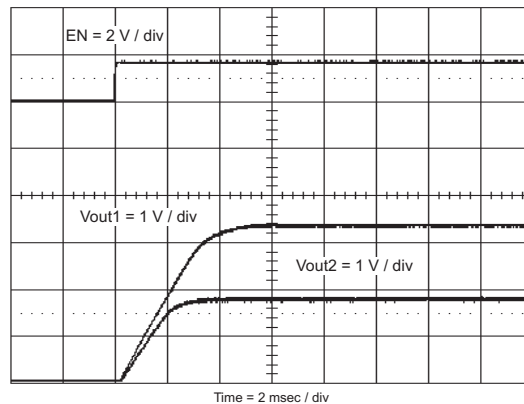
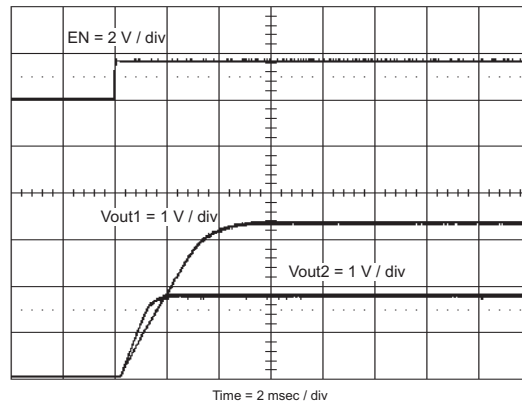
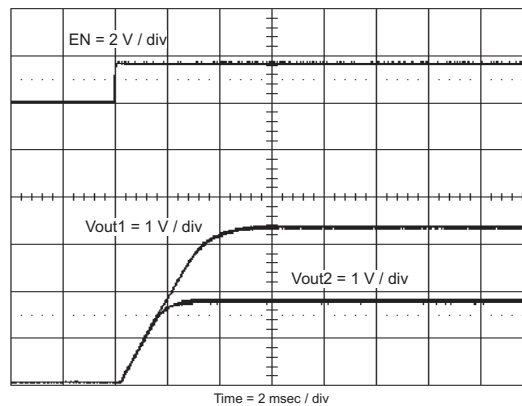

Figure 27. Ratio-metric Startup with Vout1 Leading Vout2

Figure 28. Ratio-metric Startup with Vout2 Leading Vout1

Figure 29. Simultaneous Startup

Output Overvoltage Protection (OVP)

The device incorporates an output overvoltage protection (OVP) circuit to minimize output voltage overshoot. For example, when the power supply output is overloaded, the error amplifier compares the actual output voltage to the internal reference voltage. If the VSENSE pin voltage is lower than the internal reference voltage for a considerable time, the output of the error amplifier demands maximum output current. Once the condition is removed, the regulator output rises and the error amplifier output transitions to the steady state voltage. In some applications with small output capacitance, the power supply output voltage can respond faster than the error amplifier. This leads to the possibility of an output overshoot. The OVP feature minimizes the overshoot by comparing the VSENSE pin voltage to the OVP threshold. If the VSENSE pin voltage is greater than the OVP threshold the high-side MOSFET is turned off preventing current from flowing to the output and minimizing output overshoot. When the VSENSE voltage drops lower than the OVP threshold, the high-side MOSFET is allowed to turn on at the next clock cycle.

Overcurrent Protection

The device is protected from overcurrent conditions by cycle-by-cycle current limiting on both the high-side MOSFET and the low-side MOSFET.

High-side MOSFET overcurrent protection

High-side MOSFET overcurrent protection is achieved by an internal current comparator that monitors the current in the high-side MOSFET on a cycle-by-cycle basis. If this current exceeds the current limit threshold, the high-side MOSFET is turned off for the remainder of that switching cycle.

During normal operation, the device implements current mode control which uses the COMP pin voltage to control the turn off of the high-side MOSFET and the turn on of the low-side MOSFET, on a cycle by cycle basis. Each cycle, the switch current and the current reference generated by the COMP pin voltage are compared. When the peak switch current intersects the current reference, the high-side switch is turned off.

Low-side MOSFET overcurrent protection

While the low-side MOSFET is turned on, its conduction current is monitored by the internal circuitry. During normal operation, the low-side MOSFET sources current to the load. At the end of every clock cycle, the low-side MOSFET sourcing current is compared to the internally set low-side sourcing current limit. If the low-side sourcing current is exceeded, the high-side MOSFET is not turned on and the low-side MOSFET stays on for the next cycle. The high-side MOSFET is turned on again when the low-side current is below the low-side sourcing current limit at the start of a cycle.

The low-side MOSFET may also sink current from the load. If the low-side sinking current limit is exceeded, the low-side MOSFET is turned off immediately for the rest of that clock cycle. In this scenario both MOSFETs are off until the start of the next cycle.

Furthermore, if an output overload condition (as measured by the COMP pin voltage) has lasted for more than the hiccup wait time which is programmed for 512 switching cycles, the device will shut down itself and restart after the hiccup time which is set for 16384 cycles. The hiccup mode helps to reduce the device power dissipation under severe overcurrent conditions.

Thermal Shutdown

The internal thermal shutdown circuitry forces the device to stop switching if the junction temperature exceeds 150°C typically. The device reinitiates the power up sequence when the junction temperature drops below 145°C typically.

Small Signal Model for Loop Response

Figure 30 shows an equivalent model for the device's control loop which can be modeled in a circuit simulation program to check frequency response and transient responses. The error amplifier is a transconductance amplifier with a g_m of 1300 $\mu\text{A/V}$. The error amplifier can be modeled using an ideal voltage controlled current source. The resistor R_{oea} (2.38 M Ω) and capacitor C_{oea} (20.7 pF) model the open loop gain and frequency response of the error amplifier. The 1-mV ac voltage source between the nodes a and b effectively breaks the control loop for the frequency response measurements. Plotting a/c and c/b show the small signal responses of the power stage and frequency compensation respectively. Plotting a/b shows the small signal response of the overall loop. The dynamic loop response can be checked by replacing the R_L with a current source with the appropriate load step amplitude and step rate in a time domain analysis.

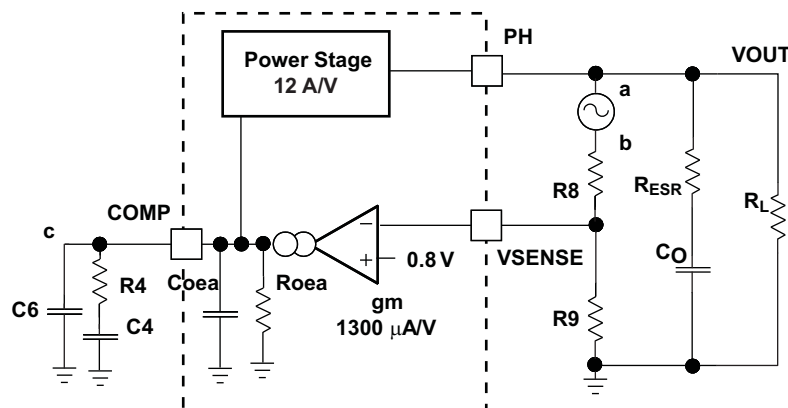

Figure 30. Small Signal Model for Loop Response

Simple Small Signal Model for Peak Current Mode Control

Figure 31 is a simple small signal model that can be used to understand how to design the frequency compensation. The device's power stage can be approximated to a voltage controlled current source (duty cycle modulator) supplying current to the output capacitor and load resistor. The control to output transfer function is shown in Equation 10 and consists of a dc gain, one dominant pole and one ESR zero. The quotient of the change in switch current and the change in COMP pin voltage (node c in Figure 30) is the power stage transconductance (gm_{ps}) which is 12 A/V for the device. The DC gain of the power stage is the product of gm_{ps} and the load resistance (R_L), as shown in Equation 11 with resistive loads. As the load current increases, the DC gain decreases. This variation with load may seem problematic at first glance, but fortunately the dominant pole moves with load current (see Equation 12). The combined effect is highlighted by the dashed line in Figure 32. As the load current decreases, the gain increases and the pole frequency lowers, keeping the 0-dB crossover frequency the same for the varying load conditions which makes it easier to design the frequency compensation.

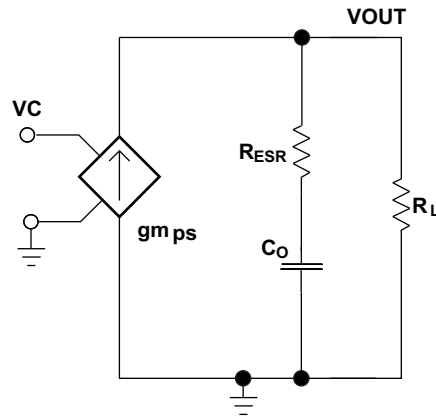

Figure 31. Simplified Small Signal Model for Peak Current Mode Control

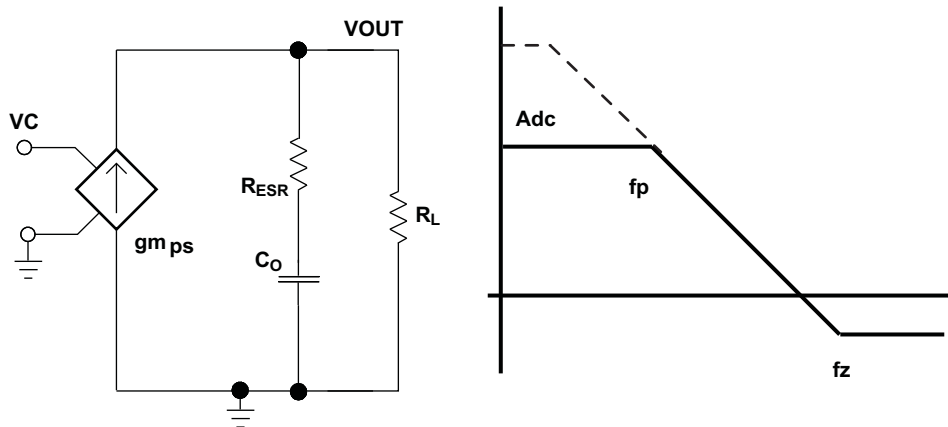

Figure 32. Simplified Frequency Response for Peak Current Mode Control

$$\frac{V_{OUT}}{VC} = A_{dc} \times \frac{\left(1 + \frac{s}{2\pi \times f_z}\right)}{\left(1 + \frac{s}{2\pi \times f_p}\right)} \quad (10)$$

$$A_{dc} = gm_{ps} \times R_L \quad (11)$$

$$f_p = \frac{1}{C_O \times R_L \times 2\pi} \quad (12)$$

$$f_z = \frac{1}{C_O \times R_{ESR} \times 2\pi} \quad (13)$$

Where

- gm_{ea} is the GM amplifier gain (1300 μ A/V)
- gm_{ps} is the power stage gain (12A/V).
- R_L is the load resistance
- C_O is the output capacitance.
- R_{ESR} is the equivalent series resistance of the output capacitor.

Small Signal Model for Frequency Compensation

The device uses a transconductance amplifier for the error amplifier and readily supports two of the commonly used Type II compensation circuits and a Type III frequency compensation circuit, as shown in Figure 33. In Type 2A, one additional high frequency pole, C6, is added to attenuate high frequency noise. In Type III, one additional capacitor, C11, is added to provide a phase boost at the crossover frequency. See *Designing Type III Compensation for Current Mode Step-Down Converters (SLVA352)* for a complete explanation of Type III compensation.

The design guidelines below are provided for advanced users who prefer to compensate using the general method. The below equations only apply to designs whose ESR zero is above the bandwidth of the control loop. This is usually true with ceramic output capacitors. See the [Application Information](#) section for a step-by-step design procedure using higher ESR output capacitors with lower ESR zero frequencies.

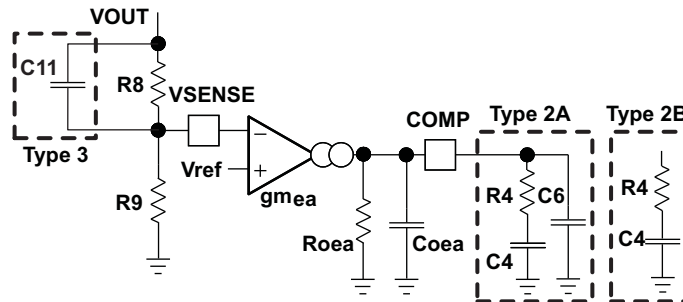

Figure 33. Types of Frequency Compensation

The general design guidelines for device loop compensation are as follows:

1. Determine the crossover frequency, f_c . A good starting point is 1/10th of the switching frequency, f_{sw} .
2. R4 can be determined by:

$$R4 = \frac{2\pi \times f_c \times V_{OUT} \times C_o}{gm_{ea} \times V_{ref} \times gm_{ps}} \quad (14)$$

Where:

- gm_{ea} is the GM amplifier gain (1300 μ A/V)
- gm_{ps} is the power stage gain (12A/V)
- V_{ref} is the reference voltage (0.8V)

3. Place a compensation zero at the dominant pole: $\left(f_p = \frac{1}{C_O \times R_L \times 2\pi} \right)$
C4 can be determined by:

$$C4 = \frac{R_L \times C_o}{R4} \quad (15)$$

4. C6 is optional. It can be used to cancel the zero from the ESR (Equivalent Series Resistance) of the output capacitor C_o .

$$C6 = \frac{R_{ESR} \times C_o}{R4} \tag{16}$$

5. Type III compensation can be implemented with the addition of one capacitor, C11. This allows for slightly higher loop bandwidths and higher phase margins. If used, C11 is calculated from Equation 17.

$$C11 = \frac{1}{(2 \cdot \pi \cdot R8 \cdot f_c)} \tag{17}$$

APPLICATION INFORMATION

Design Guide – Step-By-Step Design Procedure

This example details the design of a high frequency switching regulator using a Poscap output capacitor and Type III frequency compensation. A few parameters must be known in order to start the design process. These parameters are typically determined at the system level. For this example, we start with the following known parameters:

Table 1.

Parameter	Value
Output Voltage	5 V
Output Current	5 A
Transient Response to a 3A load step	$\Delta V_{out} = 1\%$ (50 mV)
Input Voltage	12 V nominal, 8 V to 17 V
Output Voltage Ripple	1.5% (75 mV p-p)
Start Input Voltage (Rising Vin)	6.806 V
Stop Input Voltage (Falling Vin)	4.824 V
Switching Frequency	700 kHz

Typical Application Schematic

The application schematic of Figure 34 was developed to meet the requirements above. The design procedure is given in this section. For more information about Type II and Type III frequency compensation circuits, see

Designing Type III Compensation for Current Mode Step-Down Converters (SLVA352) and *Design Calculator (SLVC219)*.

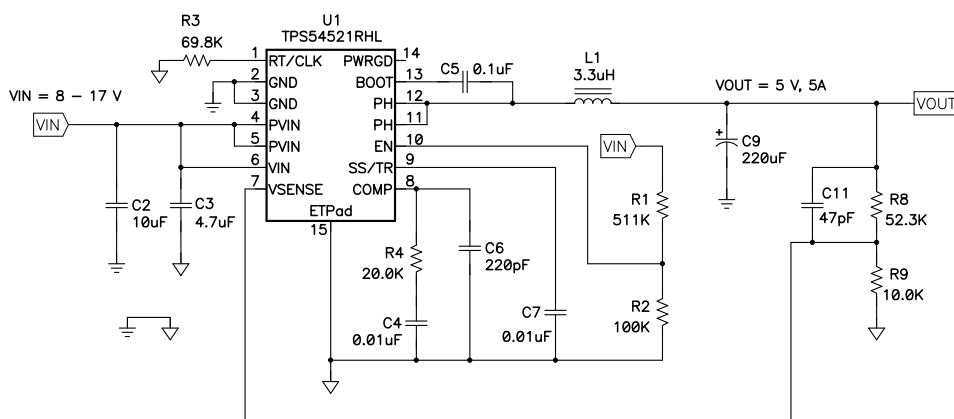

Figure 34. Typical Application Circuit

Operating Frequency

The first step is to decide on a switching frequency for the regulator. There is a trade off between higher and lower switching frequencies. Higher switching frequencies may produce a smaller solution size using lower valued inductors and smaller output capacitors compared to a power supply that switches at a lower frequency. However, the higher switching frequency causes additional switching losses, which hurt the converter's efficiency and thermal performance. In this design, a moderate switching frequency of 700 kHz is selected to achieve both a small solution size and a high efficiency operation. This frequency is set using the resistor at the RT/CLK pin (R3). Using [Equation 4](#), the resistance required for a switching frequency of 700 kHz is 69.9 kΩ. A 69.8 kΩ resistor is used for this design.

Output Inductor Selection

To calculate the value of the output inductor [Equation 18](#) is used. Kind is a coefficient that represents the amount of inductor ripple current relative to the maximum output current. The inductor ripple current is filtered by the output capacitor. Therefore, choosing high inductor ripple currents impacts the selection of the output capacitor, since the output capacitor must have a ripple current rating equal to or greater than the inductor ripple current. In general, the inductor ripple value is at the discretion of the designer; however, Kind is normally from 0.3 to 0.4 for the majority of low cost applications.

$$L1 = \frac{V_{inmax} - V_{out}}{I_{out} \cdot Kind} \cdot \frac{V_{out}}{V_{inmax} \cdot f_{sw}} \quad (18)$$

For this design example, using Kind = 0.35, the inductor value is calculated to be 2.9 μH. A 3.3 μH inductor from Coilcraft's MSS1260 series was chosen. For the output filter inductor, it is important that the RMS current and saturation current ratings not be exceeded. The inductor ripple current, RMS current, and peak inductor current can be found from [Equation 19](#), [Equation 20](#), and [Equation 21](#).

$$I_{ripple} = \frac{V_{inmax} - V_{out}}{L1} \cdot \frac{V_{out}}{V_{inmax} \cdot f_{sw}} \quad (19)$$

$$I_{Lrms} = \sqrt{I_{out}^2 + \frac{1}{12} \cdot \left(\frac{V_{out} \cdot (V_{inmax} - V_{out})}{V_{inmax} \cdot L1 \cdot f_{sw}} \right)^2} \quad (20)$$

$$I_{Lpeak} = I_{out} + \frac{I_{ripple}}{2} \quad (21)$$

For this design, the inductor ripple current is 1.53 A, the RMS inductor current is 5.02 A, and the peak inductor current is 5.76 A. The chosen inductor has a RMS current rating of 7 A and a saturation current rating of 10.4 A.

The current flowing through the inductor is the inductor ripple current plus the output current. During power up, faults, or transient load conditions, the inductor current can increase above the calculated peak inductor current level calculated above. In transient conditions, the inductor current can increase up to the switch current limit of the device. For this reason, the most conservative approach is to specify an inductor with a saturation current rating equal to or greater than the switch current limit rather than the peak inductor current.

Output Capacitor Selection

There are two primary considerations for selecting the output capacitor: the minimum capacitance required to meet the transient response specification and the maximum impedance at the switching frequency to meet the output voltage ripple requirement. Any output capacitor type (ceramic, tantalum, polymer, electrolytic, etc.) can be used with the TPS54521 to meet the design specifications.

The desired response to a large change in the load current is the first criterion. The output capacitor needs to supply the load with current when the regulator cannot. This situation would occur if there are desired hold-up times for the regulator where the output capacitor must hold the output voltage above a certain level for a specified amount of time after the input power is removed. The regulator is also temporarily not able to supply sufficient output current if there is a large, fast increase in the current needs of the load, such as transitioning from no load to full load. The regulator usually needs two or more clock cycles for the control loop to see the

change in load current and output voltage and adjust the duty cycle to react to the change. The output capacitor must be sized to supply the extra current to the load until the control loop responds to the load change. The output capacitance must be large enough to supply the difference in current for 2 clock cycles while only allowing a tolerable amount of droop in the output voltage. Equation 22 shows the minimum output capacitance necessary to accomplish this.

$$C_o > \frac{2 \cdot \Delta I_{out}}{f_{sw} \cdot \Delta V_{out}} \quad (22)$$

Where ΔI_{out} is the change in output current, f_{sw} is the regulator's switching frequency and ΔV_{out} is the allowable change in the output voltage. For this example, the transient load response is specified as a 1% change in V_{out} for a load step of 3A. Using these numbers ($\Delta I_{out} = 3.0$ A and $\Delta V_{out} = 0.01 \times 5 = 0.05$ V) gives a minimum capacitance of 171 μ F.

The next consideration is the maximum impedance at the switching frequency required to meet the output voltage ripple specification. The ripple current in the inductor is absorbed by the output capacitor and creates a ripple voltage across the capacitor's ESR and reactive impedance. Equation 23 calculates the maximum impedance to meet the ripple voltage specification of 75 mV. Equation 23 yields 49 m Ω for this design.

$$|Z_{eq}| = \frac{V_{ripple}}{I_{ripple}} \quad (23)$$

This impedance at the switching frequency is the sum of its ESR and the absolute value of its reactive impedance. Equation 24 calculates the impedance at the switching frequency for any capacitor and must yield a resultant Z_{cap} less than the Z_{eq} found in Equation 23 to meet the output voltage ripple specification. The 6TPB220M (220 μ F, 40 m Ω ESR) Poscap from Sanyo meets the impedance requirements of Equation 23 and the capacitance requirements of Equation 22.

$$|Z_{cap}| = ESR + \frac{1}{2\pi \cdot f_{sw} \cdot C_{eff}} \quad (24)$$

C_{eff} in Equation 24 is the effective capacitance of the output capacitor. This capacitance is equal to the rated capacitance for most capacitor types, except for ceramics. The capacitance of ceramic capacitors is highly dependent on the DC output voltage due to the DC bias effect, which reduces the effective capacitance as the DC voltage on the capacitor is increased. Equation 25 is used to estimate the effective capacitance of a ceramic capacitor, based on its voltage rating, the output voltage, and its nominal capacitance.

$$C_{eff} = \frac{((V_{rated} - V_{out}) \cdot C_{rated})}{V_{rated}} \quad (25)$$

Capacitors generally have limits to the amount of ripple current they can handle without failing or producing excessive heat. An output capacitor that can support the inductor ripple current must be specified. Some capacitor data sheets specify the RMS (Root Mean Square) value of the maximum ripple current. Equation 26 can be used to calculate the RMS ripple current the output capacitor needs to support. For this application, Equation 26 yields 441 mA, which is less than the output capacitor's rating of 2 A.

$$I_{corms} = \frac{V_{out} \cdot (V_{inmax} - V_{out})}{\sqrt{12} \cdot V_{inmax} \cdot L_1 \cdot f_{sw}} \quad (26)$$

Input Capacitor Selection

The TPS54521 requires a high quality ceramic, type X5R or X7R, input decoupling capacitor of roughly 4.7 μ F on each input voltage rail (V_{IN} and PV_{IN}). In some applications, additional bulk capacitance may also be required for the PV_{IN} input. The voltage rating of the input capacitor must be greater than the maximum input voltage. The capacitor must also have a ripple current rating greater than the maximum input current ripple of the TPS54521. The input ripple current for this design, using Equation 27, is 2.42 A.

$$I_{cirms} = I_{out} \cdot \sqrt{\frac{V_{out}}{V_{inmin}} \cdot \frac{(V_{inmin} - V_{out})}{V_{inmin}}} \quad (27)$$

The value of a ceramic capacitor varies significantly over temperature and the amount of DC bias applied to the capacitor. The capacitance variations due to temperature can be minimized by selecting a dielectric material that is stable over temperature. X5R and X7R ceramic dielectrics are usually selected for power regulator capacitors because they have a high capacitance to volume ratio and are fairly stable over temperature. The capacitance value of a ceramic capacitor decreases as the DC bias across a capacitor increases. For this example design, a ceramic capacitor with at least a 25 V voltage rating is required to support the maximum input voltage. For this example, one 10 μF and one 4.7 μF 25 V capacitors in parallel have been selected, as the VIN and PVIN inputs are tied together so the TPS54521 may operate from a single supply. The input capacitance value determines the input ripple voltage of the regulator. The input voltage ripple can be calculated using [Equation 28](#). Using the design example values, $I_{\text{outmax}}=5\text{ A}$, $C_{\text{in}}=14.7\ \mu\text{F}$, $F_{\text{sw}}=700\text{ kHz}$, [Equation 28](#) yields an input voltage ripple of 121 mV.

$$\Delta V_{\text{in}} = \frac{I_{\text{outmax}} \cdot 0.25}{C_{\text{in}} \cdot f_{\text{sw}}} \quad (28)$$

Slow Start Capacitor Selection

The slow start capacitor determines the minimum amount of time it takes for the output voltage to reach its nominal programmed value during power up. This is useful if a load requires a controlled voltage slew rate. This is also used if the output capacitance is very large and would require large amounts of current to quickly charge the capacitor to the output voltage level. The large currents necessary to charge the capacitor may make the TPS54521 reach the current limit or excessive current draw from the input power supply may cause the input voltage rail to sag. Limiting the output voltage slew rate solves both of these problems. The soft start capacitor value can be calculated using [Equation 29](#). The example circuit has the soft start time set to an arbitrary value of 3.5 ms which requires a 10 nF capacitor. In the TPS54521, I_{ss} is 2.3 μA and V_{ref} is 0.8 V.

$$C7(\text{nF}) = \frac{T_{\text{ss}}(\text{ms}) \cdot I_{\text{ss}}(\mu\text{A})}{V_{\text{ref}}(\text{V})} \quad (29)$$

Bootstrap Capacitor Selection

A 0.1 μF ceramic capacitor must be connected between the BOOT to PH pin for proper operation. It is recommended to use a ceramic capacitor with X5R or better grade dielectric. The capacitor should have 10 V or higher voltage rating.

Under Voltage Lockout Set Point

The Under Voltage Lock Out (UVLO) can be adjusted using the external voltage divider network of R1 and R2. R1 is connected between VIN and the EN pin of the TPS54521 and R2 is connected between EN and GND. The UVLO has two thresholds, one for power up when the input voltage is rising and one for power down or brownouts when the input voltage is falling. For the example design, the supply should turn on and start switching once the input voltage increases above 6.806V (UVLO start or enable). After the regulator starts switching, it should continue to do so until the input voltage falls below 4.824 V (UVLO stop or disable). [Equation 2](#) and [Equation 3](#) can be used to calculate the values for the upper and lower resistor values. For the stop voltages specified, the nearest standard resistor value for R1 is 511 k Ω and for R2 is 100 k Ω .

Output Voltage Feedback Resistor Selection

The resistor divider network, R8 and R9, is used to set the output voltage. For this example design, 10 k Ω was selected for R9. Using [Equation 30](#), R8 is calculated as 52.5 k Ω . The nearest standard 1% resistor is 52.3 k Ω .

$$R8 = \frac{V_{\text{out}} - V_{\text{ref}}}{V_{\text{ref}}} R9 \quad (30)$$

Minimum Output Voltage

Due to the internal design of the TPS54521, there is a minimum output voltage limit for any given input voltage. The output voltage can never be lower than the internal voltage reference of 0.8 V. Above 0.8 V, the output voltage may be limited by the minimum controllable on time. The minimum output voltage in this case is given by [Equation 31](#).

$$V_{\text{outmin}} = O_{\text{ntimemin}} \cdot F_{\text{smax}} (V_{\text{inmax}} + I_{\text{outmin}} (R_{\text{DS2min}} - R_{\text{DS1min}})) - I_{\text{outmin}} (R_{\text{L}} + R_{\text{DS2min}})$$

Where:

$$\begin{aligned}
 V_{outmin} &= \text{minimum achievable output voltage} \\
 O_{ntimemin} &= \text{minimum controllable on-time (135 nsec maximum)} \\
 F_{smax} &= \text{maximum switching frequency including tolerance} \\
 V_{inmax} &= \text{maximum input voltage} \\
 I_{outmin} &= \text{minimum load current} \\
 R_{DS1min} &= \text{minimum high side MOSFET on resistance (57 m}\Omega \text{ typical)} \\
 R_{DS2min} &= \text{minimum low side MOSFET on resistance (50 m}\Omega \text{ typical)} \\
 R_L &= \text{series resistance of output inductor}
 \end{aligned}
 \tag{31}$$

Compensation Component Selection

There are several industry techniques used to compensate DC/DC regulators. The method presented here is easy to calculate and yields high phase margins. For most conditions, the regulator has a phase margin between 60 and 90 degrees. The method presented here ignores the effects of the slope compensation that is internal to the TPS54521. Since the slope compensation is ignored, the actual crossover frequency is usually lower than the crossover frequency used in the calculations. Use SwitcherPro™ software for a more accurate design.

With the low frequency zero from the Poscap output capacitor adding phase and by using type III compensation to give an additional phase boost, a high bandwidth, high phase margin design can be realized. This design targets a crossover frequency (bandwidth) of 1/10th of the switching frequency (70 kHz).

First, the modulator pole, f_{pmod} , and the ESR zero, f_{zmod} , must be calculated using [Equation 32](#) and [Equation 33](#). They are at 723 Hz and 18.1 kHz, respectively.

$$f_{pmod} = \frac{I_{out}}{2 \cdot \pi \cdot V_{out} \cdot C_o} \tag{32}$$

$$f_{zmod} = \frac{1}{2 \cdot \pi \cdot RESR \cdot C_o} \tag{33}$$

Now the compensation components can be calculated. First, calculate the value for C6 for a crossover frequency of 70 kHz. Using [Equation 34](#), the nearest standard value for C6 is 220 pF.

$$C_6 = \frac{g_{m_{ea}} \cdot V_{ref} \cdot g_{m_{ps}} \cdot ESR}{2\pi \cdot f_c \cdot V_{out}} \tag{34}$$

Along with C6, R4 creates a pole to cancel the gain caused by the ESR zero of the power stage, f_{zmod} . To keep some of the phase from the zero, this pole is placed at roughly twice the frequency of the zero. The value of R4 needed to set the pole at the desired frequency is given by [Equation 35](#).

$$R_4 = \frac{(ESR \cdot C_o)}{(2 \cdot C_6)} \tag{35}$$

Next calculate the value of C4. Together with R4, C4 places a compensation zero at the modulator pole frequency, f_{pmod} . Use [Equation 36](#) to determine the value of C4.

$$C_4 = \frac{(V_{out} \cdot C_o)}{(I_{out} \cdot R_4)} \tag{36}$$

Using [Equation 35](#) and [Equation 36](#), the standard values for R4 and C4 are 20 kΩ and 0.01 μF.

In order to provide a zero around the crossover frequency to boost the phase at crossover, a feedforward capacitor (C11) is added in parallel to R8. The value of this capacitor is given by [Equation 37](#).

$$C_{11} = \frac{1}{(2 \cdot \pi \cdot R_8 \cdot f_c)} \tag{37}$$

The closest standard value is 47 pF.

Use of the feedforward capacitor, C11, creates a low AC impedance path from the output voltage to the VSENSE input of the IC that can couple noise at the switching frequency into the control loop. Use of a feedforward capacitor is not recommended for high output voltage ripple designs (greater than 15 mV peak to peak at the VSENSE input) operating at duty cycles of less than 30%. When using the feedforward capacitor, C11, always limit the closed loop bandwidth to no more than 1/10th of the switching frequency, f_{sw} .

Application Curves from the Design Example

LOAD TRANSIENT

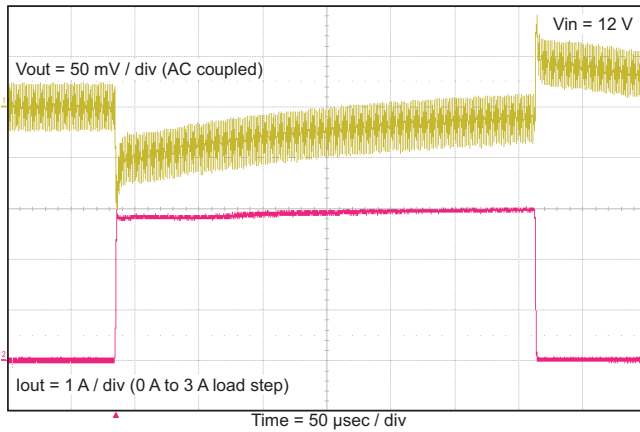

Figure 35.

STARTUP with VIN (1 Ω Load)

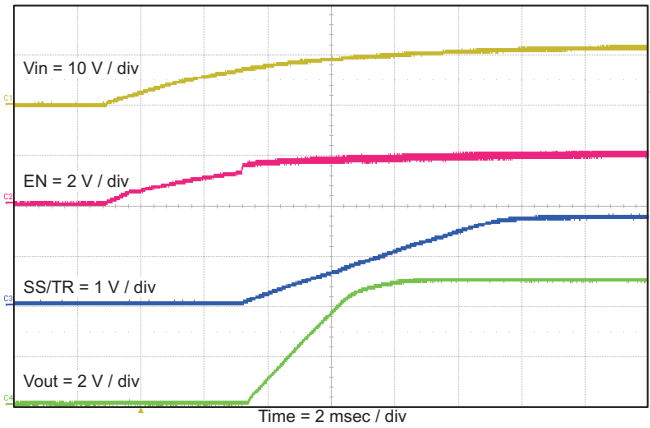

Figure 36.

STARTUP with VIN (No Load)

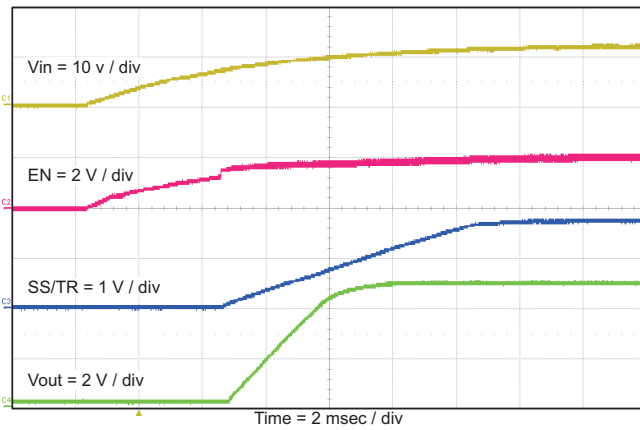

Figure 37.

STARTUP with EN (1 Ω Load)

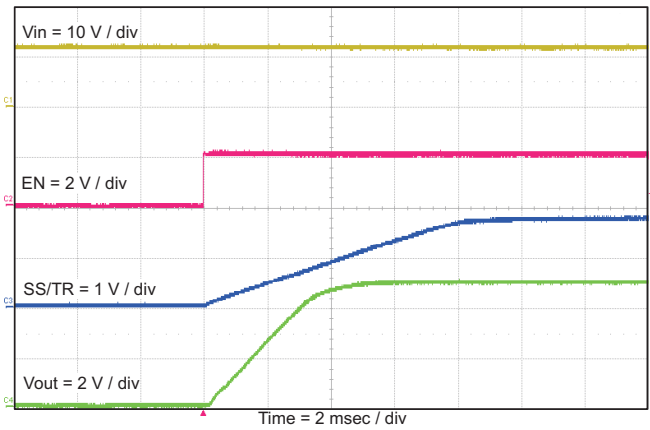

Figure 38.

STARTUP with EN (No Load)

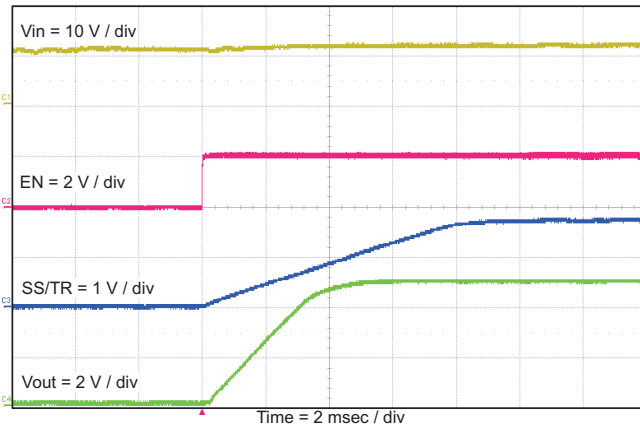

Figure 39.

STARTUP on VIN with PRE-BIAS (1 Ω Load)

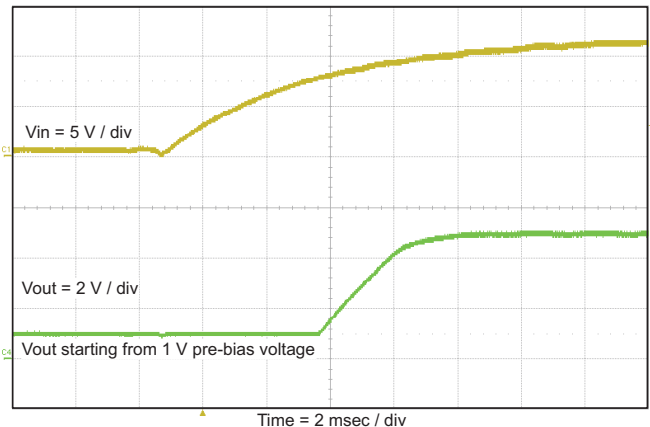

Figure 40.

STARTUP and SHUTDOWN on EN with PRE-BIAS (1 Ω Load)

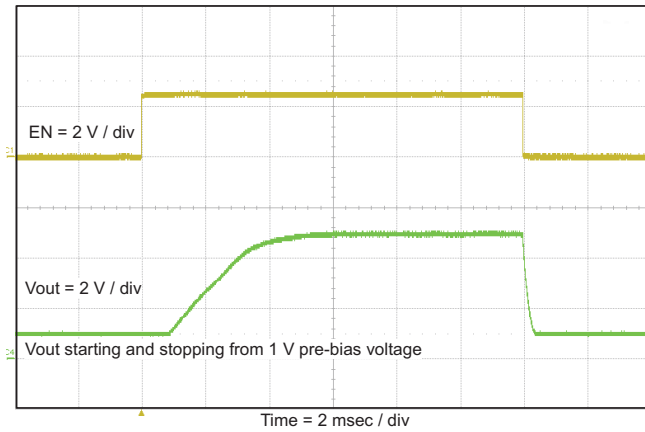

Figure 41.

SHUTDOWN with VIN (1 Ω Load)

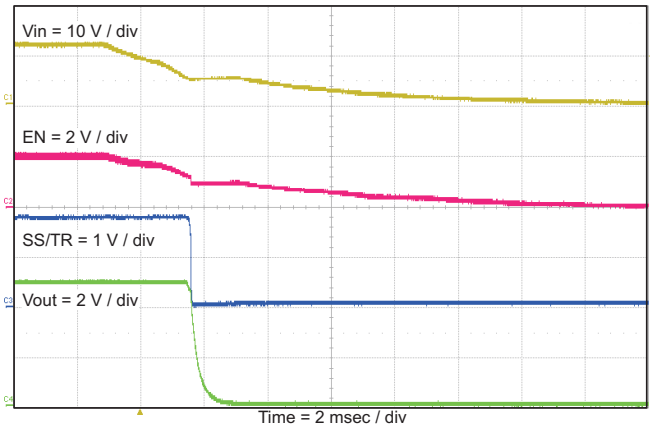

Figure 42.

SHUTDOWN with EN (1 Ω Load)

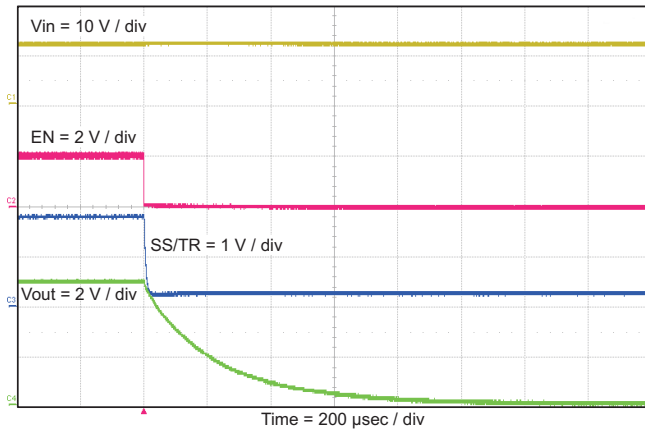

Figure 43.

OUTPUT VOLTAGE RIPPLE (1 Ω Load)

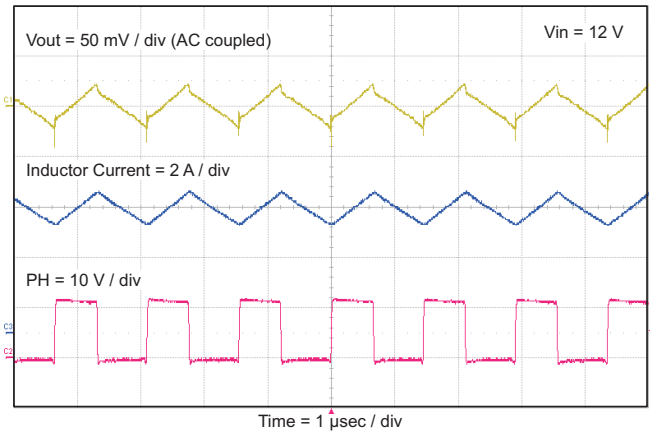

Figure 44.

INPUT VOLTAGE RIPPLE (1 Ω Load)

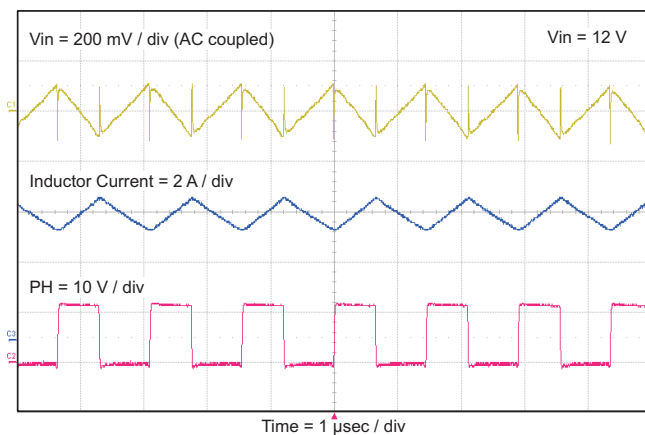

Figure 45.

OVERCURRENT HICCUP MODE

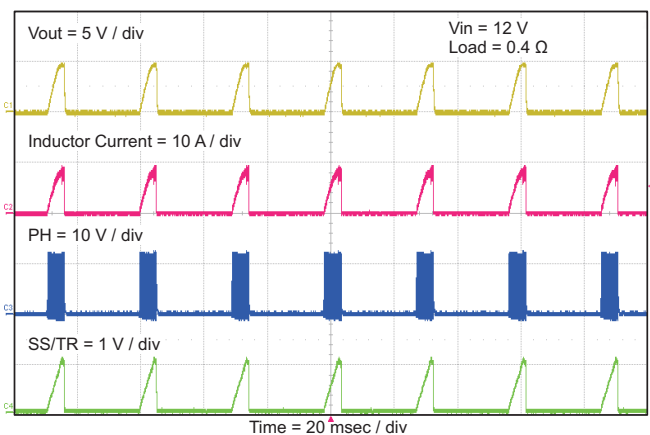

Figure 46.

CLOSED LOOP RESPONSE

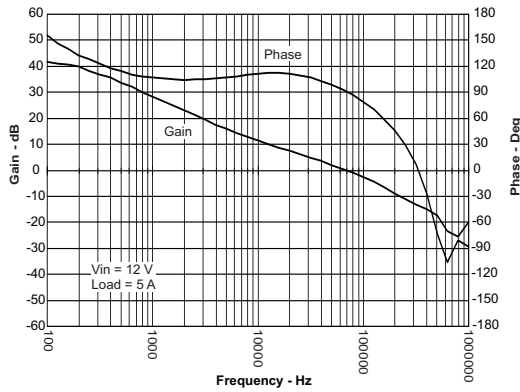

Figure 47.

LINE REGULATION

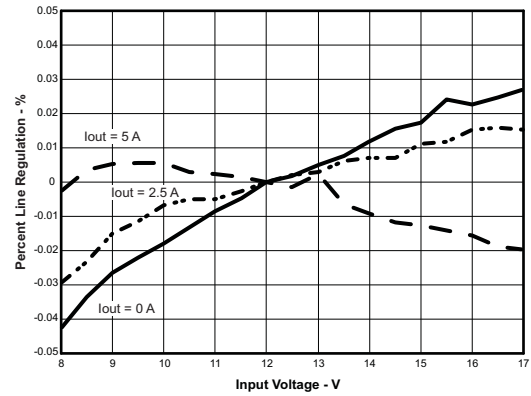

Figure 48.

LOAD REGULATION

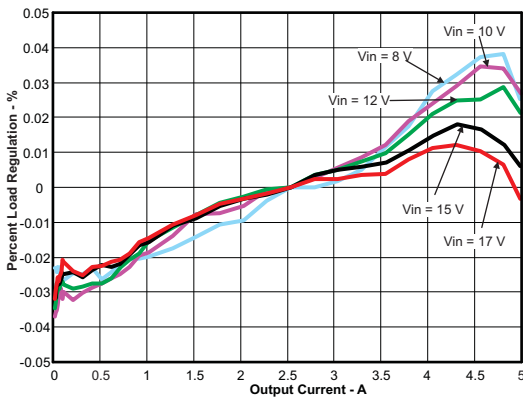

Figure 49.

TRACKING PERFORMANCE

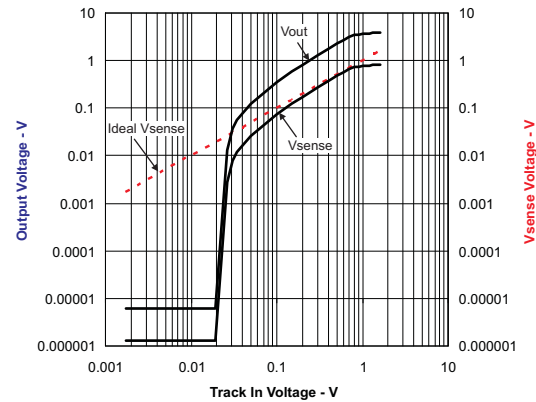

Figure 50.

MAXIMUM AMBIENT TEMPERATURE VS IC POWER DISSIPATION

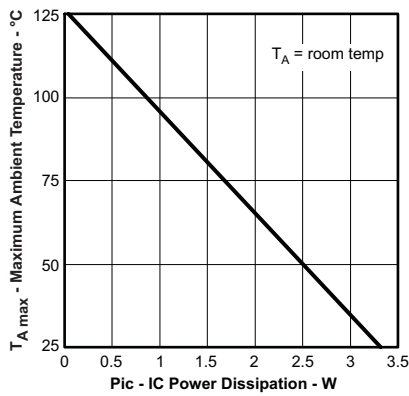

Figure 51.

JUNCTION TEMPERATURE VS IC POWER DISSIPATION

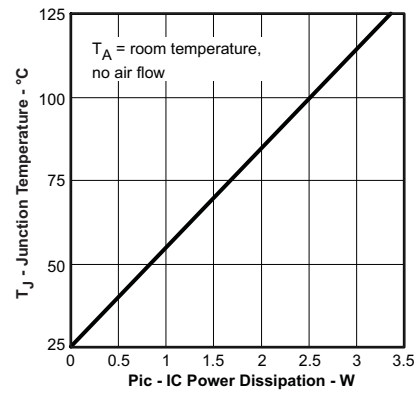

Figure 52.

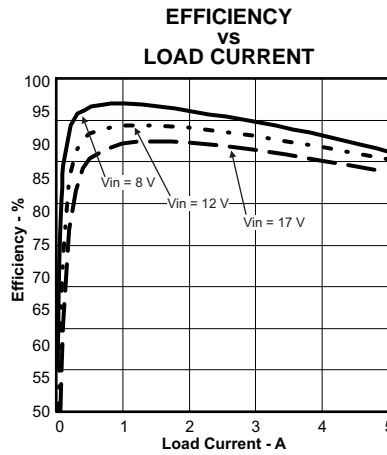

Figure 53.

Thermal Performance

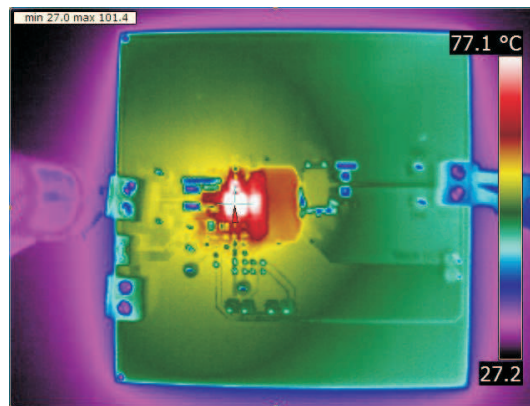

Figure 54. Thermal Signature of Example Circuit Operating at VIN=12V, VOUT=5V/5A, TA = Room Temperature

Table 2. Bill of Materials

COUNT	RefDes	Value	Description	Size	Part Number	MFR
1	C2	10µF	Capacitor, Ceramic, 25V, X5R, 20%	1206	Std	Std
1	C3	4.7µF	Capacitor, Ceramic, 25V, X5R, 10%	0805	Std	Std
2	C4, C7	0.01µF	Capacitor, Ceramic, 50V, X7R, 10%	0603	Std	Std
1	C5	0.1µF	Capacitor, Ceramic, 16V, X7R, 10%	0603	Std	Std
1	C6	220pF	Capacitor, Ceramic, 50V, C0G, 5%	0603	Std	Std
1	C9	220µF	Capacitor, Polymer, 6.3V, 40 mΩ ESR, ±20%	0.138 x 0.110 inch	6TPB220M	Sanyo
1	C11	47pF	Capacitor, Ceramic, 50V, C0G, 5%	0603	Std	Std
1	L1	3.3µH	Inductor, 12.6mΩ DCR, 7A, ± 30%	0.484 x 0.484 inch	MSS1260-332NL	Coilcraft
1	R1	511K	Resistor, Chip, 1/16W, 1%	0603	Std	Std
1	R2	100K	Resistor, Chip, 1/16W, 1%	0603	Std	Std
1	R3	69.8K	Resistor, Chip, 1/16W, 1%	0603	Std	Std
1	R4	20K	Resistor, Chip, 1/16W, 1%	0603	Std	Std
1	R8	52.3K	Resistor, Chip, 1/16W, 1%	0603	Std	Std
1	R9	10.0K	Resistor, Chip, 1/16W, 1%	0603	Std	Std

Table 2. Bill of Materials (continued)

COUNT	RefDes	Value	Description	Size	Part Number	MFR
1	U1	TPS54521RHL	IC, 17V Input, 5A Output, Sync. Step Down Switcher With Integrated FET	QFN14	TPS54521RHL	TI

PCB Layout Guidelines

Layout is a critical portion of good power supply design. See [Figure 55](#) for a PCB layout example. The top layer contains the main power traces for VIN, VOUT, and the PH node. Also on the top layer are connections for the remaining pins of the TPS54521 and a large top side area filled with ground. The top layer ground area should be connected to the internal ground layer(s) using vias at the input bypass capacitor, the output filter capacitor and directly under the TPS54521 device to provide a thermal path from the exposed thermal pad land to ground. The GND pin should be tied directly to the exposed thermal pad under the IC. For operation at full rated load, the top side ground area together with the internal ground plane, must provide adequate heat dissipating area. There are several signals paths that conduct fast changing currents or voltages that can interact with stray inductance or parasitic capacitance to generate noise or degrade the power supply's performance. To help eliminate these problems, the PVIN pin should be bypassed to ground with a low ESR ceramic bypass capacitor with X5R or X7R dielectric. Care should be taken to minimize the loop area formed by the bypass capacitor connections, the PVIN pins, and the ground connections. The VIN pin must also be bypassed to ground using a low ESR ceramic capacitor with X5R or X7R dielectric. Make sure to connect this capacitor to the quiet analog ground trace rather than the power ground trace of the PVIN bypass capacitor. Since the PH connection is the switching node, the output inductor should be located close to the PH pins, and the area of the PCB conductor minimized to prevent excessive capacitive coupling. The output filter capacitor ground should use the same power ground trace as the PVIN input bypass capacitor. Try to minimize this conductor length while maintaining adequate width. The small signal components should be grounded to the analog ground path as shown. The RT/CLK pin is sensitive to noise so the RT resistor should be located as close as possible to the IC and routed with minimal lengths of trace. The additional external components can be placed approximately as shown. It may be possible to obtain acceptable performance with alternate PCB layouts. However, this layout has been shown to produce good results and is meant as a guideline.

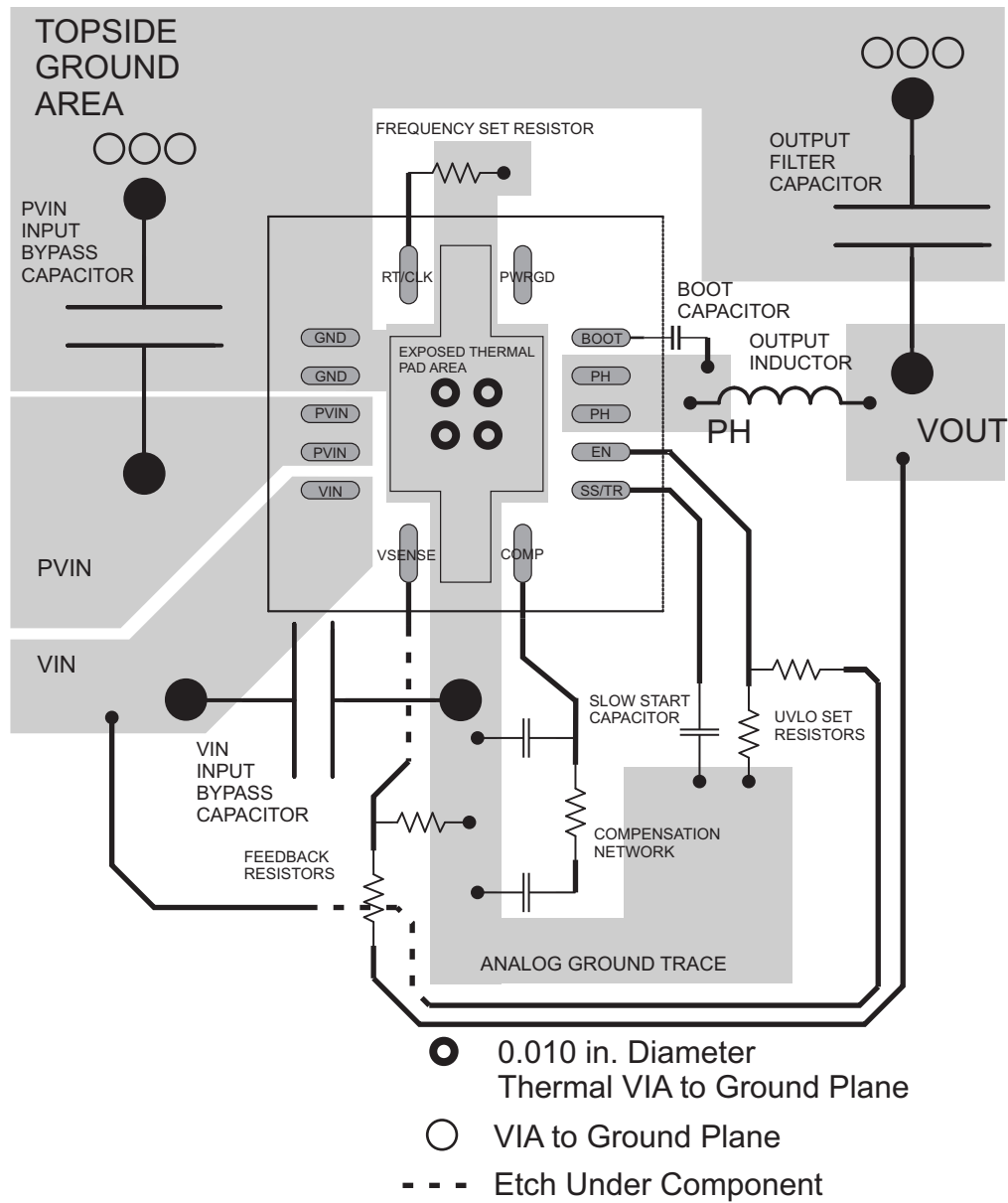

Figure 55. PCB Layout

Estimated Circuit Area

The estimated printed circuit board area for the components used in the design of Figure 34 is 0.5 in² (323 mm²). This area does not include test points or connectors.

REVISION HISTORY

Changes from Original (July 2010) to Revision A	Page
• Added "Type 3" block around C11	21
• Changed Equation 25	24
• Changed graphics in Application Curves from the Design Example section	27
• Deleted graph JUNCTION TEMPERATURE vs LOAD CURRENT	29
• Changed Figure 54	30
<hr/>	
Changes from Revision A (August 2010) to Revision B	Page
• Deleted Swift™ from the data sheet title	1
• Deleted Feature Item: For SWIFT™ Documentation and SwitcherPro™, visit http://www.ti.com/swift	1
<hr/>	
Changes from Revision B (February 2012) to Revision C	Page
• Changed BOOT-PH From: 0 to 7 V To: 0 to 8 V in the ABSOLUTE MAXIMUM RATINGS table	2

PACKAGING INFORMATION

Orderable Device	Status (1)	Package Type	Package Drawing	Pins	Package Qty	Eco Plan (2)	Lead finish/ Ball material (6)	MSL Peak Temp (3)	Op Temp (°C)	Device Marking (4/5)	Samples
TPS54521RHLLR	ACTIVE	VQFN	RHL	14	3000	RoHS & Green	NIPDAU	Level-2-260C-1 YEAR	-40 to 125	54521	Samples
TPS54521RHLLT	ACTIVE	VQFN	RHL	14	250	RoHS & Green	NIPDAU	Level-2-260C-1 YEAR	-40 to 125	54521	Samples

(1) The marketing status values are defined as follows:

ACTIVE: Product device recommended for new designs.

LIFEBUY: TI has announced that the device will be discontinued, and a lifetime-buy period is in effect.

NRND: Not recommended for new designs. Device is in production to support existing customers, but TI does not recommend using this part in a new design.

PREVIEW: Device has been announced but is not in production. Samples may or may not be available.

OBSOLETE: TI has discontinued the production of the device.

(2) **RoHS:** TI defines "RoHS" to mean semiconductor products that are compliant with the current EU RoHS requirements for all 10 RoHS substances, including the requirement that RoHS substance do not exceed 0.1% by weight in homogeneous materials. Where designed to be soldered at high temperatures, "RoHS" products are suitable for use in specified lead-free processes. TI may reference these types of products as "Pb-Free".

RoHS Exempt: TI defines "RoHS Exempt" to mean products that contain lead but are compliant with EU RoHS pursuant to a specific EU RoHS exemption.

Green: TI defines "Green" to mean the content of Chlorine (Cl) and Bromine (Br) based flame retardants meet JS709B low halogen requirements of <=1000ppm threshold. Antimony trioxide based flame retardants must also meet the <=1000ppm threshold requirement.

(3) MSL, Peak Temp. - The Moisture Sensitivity Level rating according to the JEDEC industry standard classifications, and peak solder temperature.

(4) There may be additional marking, which relates to the logo, the lot trace code information, or the environmental category on the device.

(5) Multiple Device Markings will be inside parentheses. Only one Device Marking contained in parentheses and separated by a "~" will appear on a device. If a line is indented then it is a continuation of the previous line and the two combined represent the entire Device Marking for that device.

(6) Lead finish/Ball material - Orderable Devices may have multiple material finish options. Finish options are separated by a vertical ruled line. Lead finish/Ball material values may wrap to two lines if the finish value exceeds the maximum column width.

Important Information and Disclaimer:The information provided on this page represents TI's knowledge and belief as of the date that it is provided. TI bases its knowledge and belief on information provided by third parties, and makes no representation or warranty as to the accuracy of such information. Efforts are underway to better integrate information from third parties. TI has taken and continues to take reasonable steps to provide representative and accurate information but may not have conducted destructive testing or chemical analysis on incoming materials and chemicals. TI and TI suppliers consider certain information to be proprietary, and thus CAS numbers and other limited information may not be available for release.

In no event shall TI's liability arising out of such information exceed the total purchase price of the TI part(s) at issue in this document sold by TI to Customer on an annual basis.

TAPE AND REEL INFORMATION

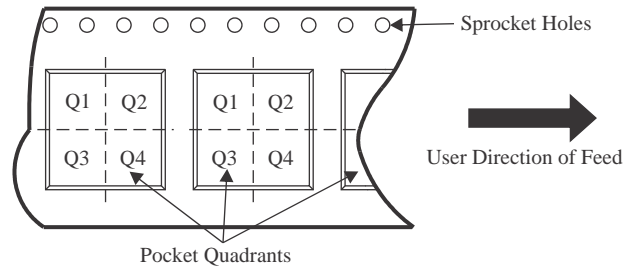
QUADRANT ASSIGNMENTS FOR PIN 1 ORIENTATION IN TAPE

*All dimensions are nominal

Device	Package Type	Package Drawing	Pins	SPQ	Reel Diameter (mm)	Reel Width W1 (mm)	A0 (mm)	B0 (mm)	K0 (mm)	P1 (mm)	W (mm)	Pin1 Quadrant
TPS54521RHLR	VQFN	RHL	14	3000	330.0	12.4	3.75	3.75	1.15	8.0	12.0	Q1
TPS54521RHLL	VQFN	RHL	14	250	180.0	12.4	3.75	3.75	1.15	8.0	12.0	Q1

TAPE AND REEL BOX DIMENSIONS

*All dimensions are nominal

Device	Package Type	Package Drawing	Pins	SPQ	Length (mm)	Width (mm)	Height (mm)
TPS54521RHRLR	VQFN	RHL	14	3000	356.0	356.0	35.0
TPS54521RHILT	VQFN	RHL	14	250	210.0	185.0	35.0

EXAMPLE BOARD LAYOUT

RHL0014A

VQFN - 1 mm max height

PLASTIC QUAD FLATPACK - NO LEAD

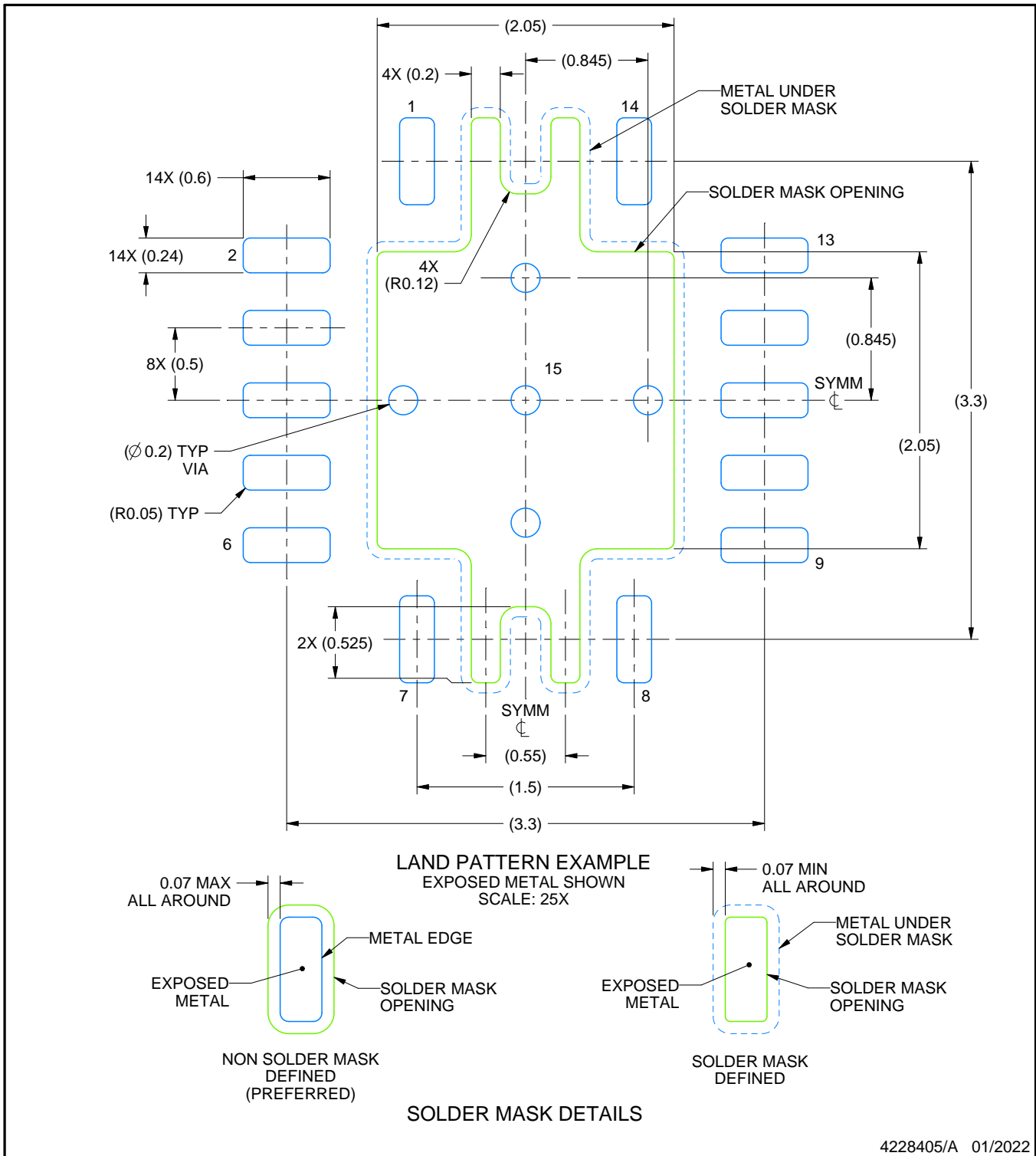

4228405/A 01/2022

NOTES: (continued)

4. This package is designed to be soldered to a thermal pad on the board. For more information, see Texas Instruments literature number SLUA271 (www.ti.com/lit/sluea271).
5. Solder mask tolerances between and around signal pads can vary based on board fabrication site.
6. Vias are optional depending on application, refer to device data sheet. If any vias are implemented, refer to their locations shown on this view. It is recommended that vias under paste be filled, plugged or tented.

EXAMPLE STENCIL DESIGN

RHL0014A

VQFN - 1 mm max height

PLASTIC QUAD FLATPACK - NO LEAD

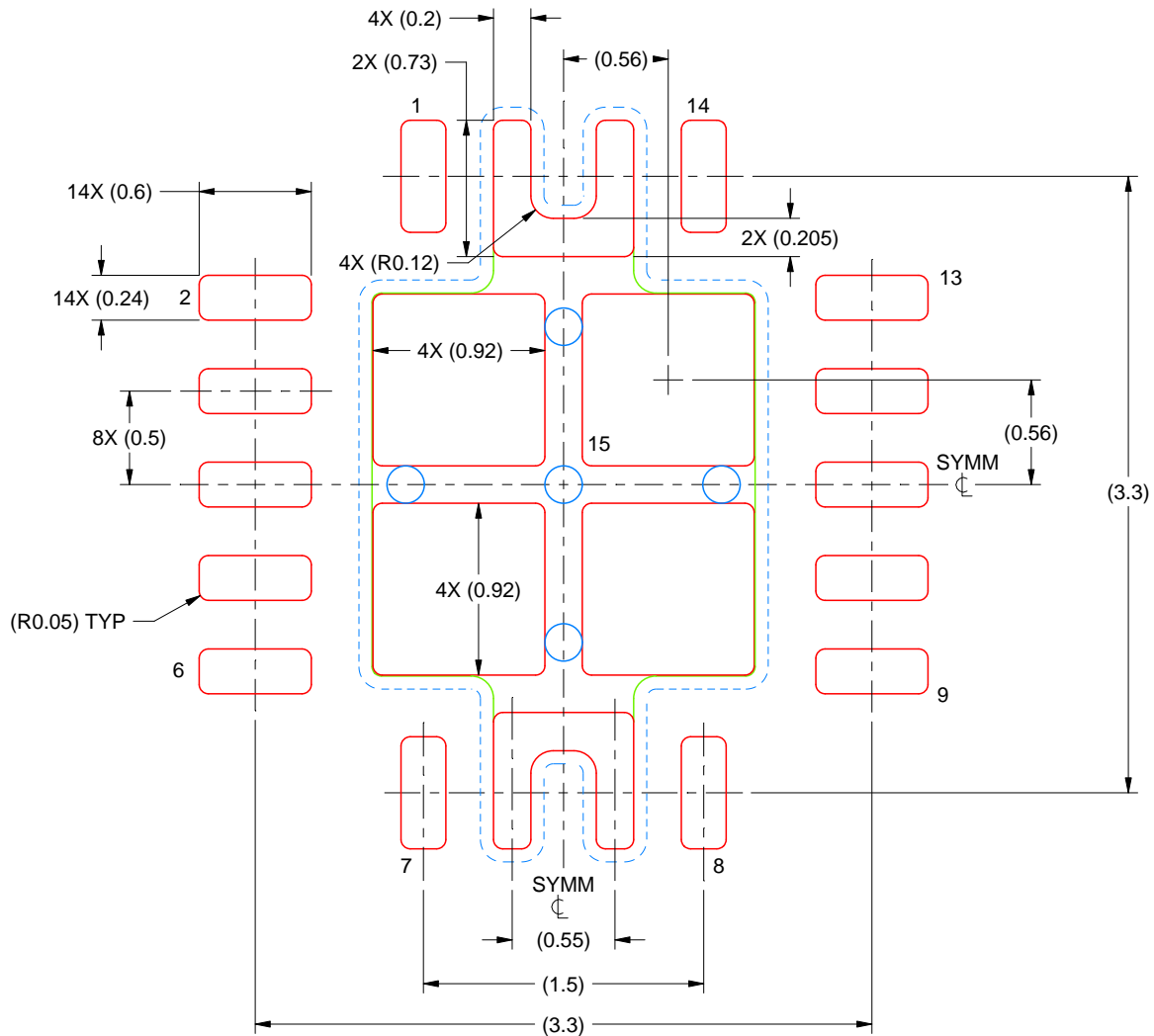

SOLDER PASTE EXAMPLE
 BASED ON 0.125 mm THICK STENCIL

EXPOSED PAD
 79% PRINTED COVERAGE BY AREA
 SCALE: 25X

4228405/A 01/2022

NOTES: (continued)

7. Laser cutting apertures with trapezoidal walls and rounded corners may offer better paste release. IPC-7525 may have alternate design recommendations.

IMPORTANT NOTICE AND DISCLAIMER

TI PROVIDES TECHNICAL AND RELIABILITY DATA (INCLUDING DATA SHEETS), DESIGN RESOURCES (INCLUDING REFERENCE DESIGNS), APPLICATION OR OTHER DESIGN ADVICE, WEB TOOLS, SAFETY INFORMATION, AND OTHER RESOURCES "AS IS" AND WITH ALL FAULTS, AND DISCLAIMS ALL WARRANTIES, EXPRESS AND IMPLIED, INCLUDING WITHOUT LIMITATION ANY IMPLIED WARRANTIES OF MERCHANTABILITY, FITNESS FOR A PARTICULAR PURPOSE OR NON-INFRINGEMENT OF THIRD PARTY INTELLECTUAL PROPERTY RIGHTS.

These resources are intended for skilled developers designing with TI products. You are solely responsible for (1) selecting the appropriate TI products for your application, (2) designing, validating and testing your application, and (3) ensuring your application meets applicable standards, and any other safety, security, regulatory or other requirements.

These resources are subject to change without notice. TI grants you permission to use these resources only for development of an application that uses the TI products described in the resource. Other reproduction and display of these resources is prohibited. No license is granted to any other TI intellectual property right or to any third party intellectual property right. TI disclaims responsibility for, and you will fully indemnify TI and its representatives against, any claims, damages, costs, losses, and liabilities arising out of your use of these resources.

TI's products are provided subject to [TI's Terms of Sale](#) or other applicable terms available either on ti.com or provided in conjunction with such TI products. TI's provision of these resources does not expand or otherwise alter TI's applicable warranties or warranty disclaimers for TI products.

TI objects to and rejects any additional or different terms you may have proposed.

Mailing Address: Texas Instruments, Post Office Box 655303, Dallas, Texas 75265
Copyright © 2022, Texas Instruments Incorporated

Looking for pricing, stock, or lifecycle information?

Click below to explore more details on WIN SOURCE:

 [View TPS54521RHRLR on WIN SOURCE](#)

 [Texas Instruments](#) Information

Optimize Your Supply Chain with WIN SOURCE Solutions

-  Global Sourcing Solution
-  Obsolete Management
-  Cost Control Management
-  Shortage Management
-  Alternative Solution
-  Excess Inventory Management