



THE DATASHEET OF TPS54528DDA



TPS54528 4.5-V To 18-V Input, 5-A Synchronous Step-Down Converter With Eco-Mode™

1 Features

- D-CAP2™ Mode Enables Fast Transient Response
- Low Output Ripple and Allows Ceramic Output Capacitor
- Wide V_{IN} Input Voltage Range: 4.5 V to 18 V
- Output Voltage Range: 0.76 V to 6 V
- Highly Efficient Integrated FETs Optimized for Lower Duty Cycle Applications
 - 65 m Ω (High Side) and 36 m Ω (Low Side)
- High Efficiency, less than 10 μ A at shutdown
- High Initial Bandgap Reference Accuracy
- Adjustable Soft Start
- Pre-Biased Soft Start
- 650-kHz Switching Frequency (f_{sw})
- Cycle By Cycle Over Current Limit
- Auto-Skip Eco-mode™ for High Efficiency at Light Load

2 Applications

- Wide Range of Applications for Low Voltage System
 - Digital TV Power Supply
 - High Definition Blu-ray Disc™ Players
 - Networking Home Terminal
 - Digital Set Top Box (STB)

4 Simplified Schematic

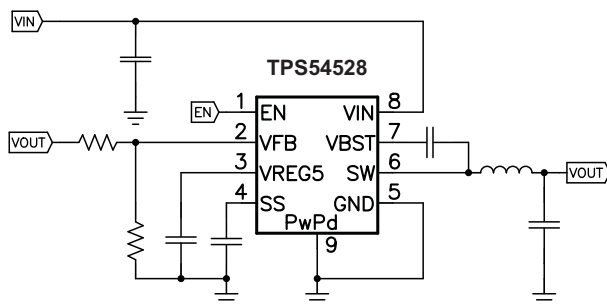

3 Description

The TPS54528 is an adaptive on-time D-CAP2™ mode synchronous buck converter. The TPS54528 enables system designers to complete the suite of various end-equipment power bus regulators with a cost effective, low component count, low standby current solution. The main control loop for the TPS54528 uses the D-CAP2™ mode control that provides a fast transient response with no external compensation components. The adaptive on-time control supports seamless transition between PWM mode at higher load conditions and Eco-mode™ operation at light loads. Eco-mode™ allows the TPS54528 to maintain high efficiency during lighter load conditions. The TPS54528 also has a proprietary circuit that enables the device to adopt to both low equivalent series resistance (ESR) output capacitors, such as POSCAP or SP-CAP, and ultra-low ESR ceramic capacitors. The device operates from 4.5-V to 18-V V_{IN} input. The output voltage can be programmed between 0.76 V and 6 V. The device also features an adjustable soft start time. The TPS54528 is available in the 8-terminal DDA package, and designed to operate from -40°C to 85°C .

Device Information

ORDER NUMBER	PACKAGE	BODY SIZE
TPS54528DDA	HSOP (8)	4,89 mm x 3,9 mm

1.05-V, Load Transient Response

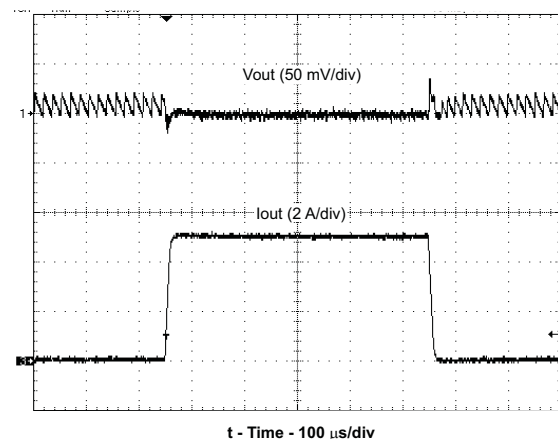

Table of Contents

1 Features	1	8.3 Feature Description	9
2 Applications	1	8.4 Device Functional Modes	10
3 Description	1	9 Applications and Implementation	12
4 Simplified Schematic	1	9.1 Application Information	12
5 Revision History	2	9.2 Typical Application	12
6 Terminal Configuration and Functions	3	10 Power Supply Recommendations	15
7 Specifications	4	11 Layout	15
7.1 Absolute Maximum Ratings	4	11.1 Layout Guidelines	15
7.2 Handling Ratings	4	11.2 Layout Example	16
7.3 Recommended Operating Conditions	4	11.3 Thermal Information	17
7.4 Thermal Information	5	12 Device and Documentation Support	18
7.5 Electrical Characteristics	5	12.1 Documentation Support	18
7.6 Timing Requirements - On-Time Timer Control	6	12.2 Trademarks	18
7.7 Typical Characteristics	6	12.3 Electrostatic Discharge Caution	18
8 Detailed Description	9	12.4 Glossary	18
8.1 Overview	9	13 Mechanical, Packaging, and Orderable Information	18
8.2 Functional Block Diagram	9		

5 Revision History

NOTE: Page numbers for previous revisions may differ from page numbers in the current version.

Changes from Revision B (May 2012) to Revision C	Page
• Formatted data sheet to meet new template requirements	1
• Added Table of Contents, and moved Revision History to page 2.	3
• Moved ABS Max, Handling Ratings, ROC, Thermal Info, and Electrical Characteristics tables to the new "Specifications" section.	4
• Added Maximum Power Dissipation graph	8
• Added "Power Supply Recommendations" section	15
• Added "Device and Documentation Support" section	18

Changes from Revision A (January 2012) to Revision B	Page
• Changed $t_{OFF(MIN)}$ From: 310 ns To: 330 ns	6

Changes from Original (July 2011) to Revision A	Page
• Added CONDITIONS statement at the Typical Characteristics section heading	6
• Changed 2- μ A to 6 μ A in Soft Start and Pre-Biased Soft Start subsection and denominator in equation 2	9

6 Terminal Configuration and Functions

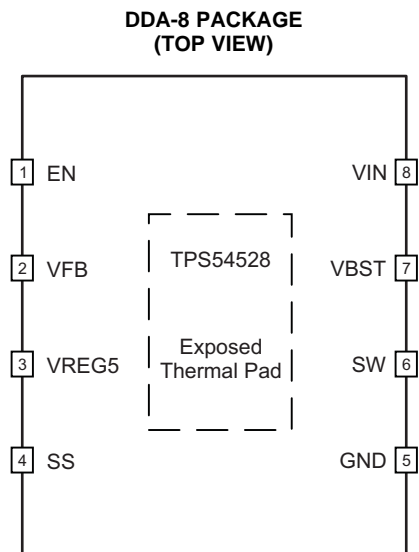

Terminal Functions

TERMINAL		DESCRIPTION
NAME	NO.	
EN	1	Enable input control. EN is active high and must be pulled up to enable the device.
VFB	2	Converter feedback input. Connect to output voltage with feedback resistor divider.
VREG5	3	5.5 V power supply output. A capacitor (typical 1 μ F) should be connected to GND. VREG5 is not active when EN is low.
SS	4	Soft-start control. An external capacitor should be connected to GND.
GND	5	Ground terminal. Power ground return for switching circuit. Connect sensitive SS and VFB returns to GND at a single point.
SW	6	Switch node connection between high-side NFET and low-side NFET.
VBST	7	Supply input for the high-side FET gate drive circuit. Connect 0.1 μ F capacitor between VBST and SW terminals. An internal diode is connected between VREG5 and VBST.
VIN	8	Input voltage supply terminal.
Exposed Thermal Pad	Back side	Thermal pad of the package. Must be soldered to achieve appropriate dissipation. Must be connected to GND.

7 Specifications

7.1 Absolute Maximum Ratings

over operating free-air temperature range (unless otherwise noted) ⁽¹⁾

		VALUE		UNIT
		MIN	MAX	
Input voltage range	VIN, EN	−0.3	20	V
	VBST	−0.3	26	
	VBST (10 ns transient)	−0.3	28	
	VBST (vs SW)	−0.3	6.5	
	VFB, SS	−0.3	6.5	
	SW	−2	20	
	SW (10 ns transient)	−3	22	
Output voltage range	VREG5	−0.3	6.5	V
	GND	−0.3	0.3	
Voltage from GND to thermal pad, V_{diff}		−0.2	0.2	V
Operating junction temperature, T_J		−40	150	°C

(1) Stresses beyond those listed under *Absolute Maximum Ratings* may cause permanent damage to the device. These are stress ratings only, which do not imply functional operation of the device at these or any other conditions beyond those indicated under *Recommended Operating Conditions*. Exposure to absolute-maximum-rated conditions for extended periods may affect device reliability.

7.2 Handling Ratings

		MIN	MAX	UNIT
T_{stg}	Storage temperature range	−55	150	°C
Electrostatic discharge	Human Body Model (HBM)		2	kV
	Charged Device Model (CDM)		500	V

7.3 Recommended Operating Conditions

over operating free-air temperature range (unless otherwise noted)

		MIN	MAX	UNIT	
V_{IN}	Supply input voltage	4.5	18	V	
V_I	Input voltage	VBST	−0.1	24	V
		VBST (10 ns transient)	−0.1	27	
		VBST(vs SW)	−0.1	5.7	
		SS	−0.1	5.7	
		EN	−0.1	18	
		VFB	−0.1	5.5	
		SW	−1.8	18	
		SW (10 ns transient)	−3	21	
V_O	Output voltage	VREG5	−0.1	5.7	V
I_O	Output Current	I_{VREG5}	0	5	mA
T_A	Operating free-air temperature	−40	85	°C	
T_J	Operating junction temperature	−40	150	°C	

7.4 Thermal Information

THERMAL METRIC ⁽¹⁾		TPS54528	UNIT
		DDA (8)	
θ_{JA}	Junction-to-ambient thermal resistance	43.5	°C/W
θ_{JCTop}	Junction-to-case (top) thermal resistance	49.4	
θ_{JB}	Junction-to-board thermal resistance	25.6	
Ψ_{JT}	Junction-to-top characterization parameter	7.4	
Ψ_{JB}	Junction-to-board characterization parameter	25.5	
θ_{JCbot}	Junction-to-case (bottom) thermal resistance	5.2	

(1) For more information about traditional and new thermal metrics, see the *IC Package Thermal Metrics* application report, [SPRA953](#).

7.5 Electrical Characteristics

over operating free-air temperature range, $V_{IN} = 12\text{ V}$ (unless otherwise noted)

PARAMETER		TEST CONDITIONS	MIN	TYP	MAX	UNIT
SUPPLY CURRENT						
I_{VIN}	Operating - non-switching supply current	V_{IN} current, $T_A = 25^\circ\text{C}$, $EN = 5\text{ V}$, $V_{FB} = 0.8\text{ V}$		900	1200	μA
I_{VINSDN}	Shutdown supply current	V_{IN} current, $T_A = 25^\circ\text{C}$, $EN = 0\text{ V}$		3.6	10	μA
LOGIC THRESHOLD						
V_{EN}	EN high-level input voltage	EN	1.6			V
	EN low-level input voltage	EN			0.6	V
V_{FB} VOLTAGE AND DISCHARGE RESISTANCE						
V_{FBTH}	V_{FB} threshold voltage	$T_A = 25^\circ\text{C}$, $V_O = 1.05\text{ V}$, $I_O = 10\text{ mA}$, Eco-mode™ operation		771		mV
		$T_A = 25^\circ\text{C}$, $V_O = 1.05\text{ V}$, continuous mode operation	757	765	773	mV
		$T_A = -40$ to 85°C , $V_O = 1.05\text{ V}$, continuous mode operation ⁽¹⁾	751	765	779	mV
I_{VFB}	V_{FB} input current	$V_{FB} = 0.8\text{ V}$, $T_A = 25^\circ\text{C}$		0	± 0.15	μA
V_{REG5} OUTPUT						
V_{VREG5}	V_{REG5} output voltage	$T_A = 25^\circ\text{C}$, $6.0\text{ V} < V_{IN} < 18\text{ V}$, $0 < I_{VREG5} < 5\text{ mA}$	5.2	5.5	5.7	V
V_{LN5}	Line regulation	$6\text{ V} < V_{IN} < 18\text{ V}$, $I_{VREG5} = 5\text{ mA}$			25	mV
V_{LD5}	Load regulation	$0\text{ mA} < I_{VREG5} < 5\text{ mA}$			100	mV
I_{VREG5}	Output current	$V_{IN} = 6\text{ V}$, $V_{REG5} = 4.0\text{ V}$, $T_A = 25^\circ\text{C}$		60		mA
MOSFET						
$R_{DS(on)}$	High side switch resistance	25°C , $V_{BST} - SW = 5.5\text{ V}$		65		m Ω
	Low side switch resistance	25°C		36		m Ω
CURRENT LIMIT						
I_{ocL}	Current limit	L out = $1.5\text{ }\mu\text{H}$ ⁽¹⁾	5.6	6.4	7.9	A
THERMAL SHUTDOWN						
T_{SDN}	Thermal shutdown threshold	Shutdown temperature ⁽¹⁾		165		°C
		Hysteresis ⁽¹⁾		35		

(1) Not production tested.

Electrical Characteristics (continued)

over operating free-air temperature range, $V_{IN} = 12\text{ V}$ (unless otherwise noted)

PARAMETER		TEST CONDITIONS	MIN	TYP	MAX	UNIT
SOFT START						
I_{SS}	SS charge current	$V_{SS} = 1\text{ V}$	4.2	6	7.8	μA
	SS discharge current	$V_{SS} = 0.5\text{ V}$	0.1	0.2		mA
UVLO						
UVLO	UVLO threshold	Wake up V_{REG5} voltage	3.45	3.75	4.05	V
		Hysteresis V_{REG5} voltage	0.19	0.32	0.45	

7.6 Timing Requirements - On-Time Timer Control

			MIN	TYP	MAX	UNIT
t_{ON}	On time	$V_{IN} = 12\text{ V}, V_O = 1.05\text{ V}$		150		ns
$t_{OFF(MIN)}$	Minimum off time	$T_A = 25^\circ\text{C}, V_{FB} = 0.7\text{ V}$		260	330	ns

7.7 Typical Characteristics

$V_{IN} = 12\text{ V}, T_A = 25^\circ\text{C}$ (unless otherwise noted).

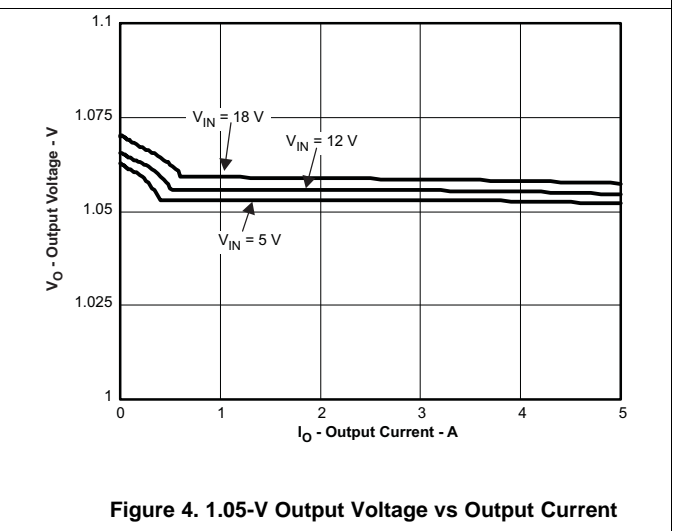
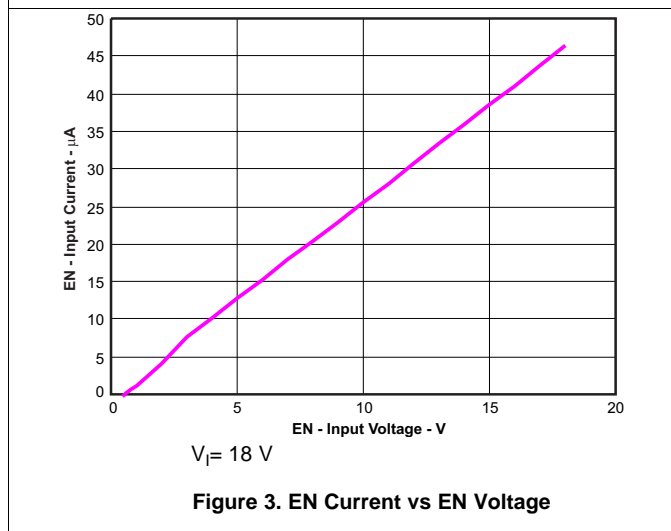
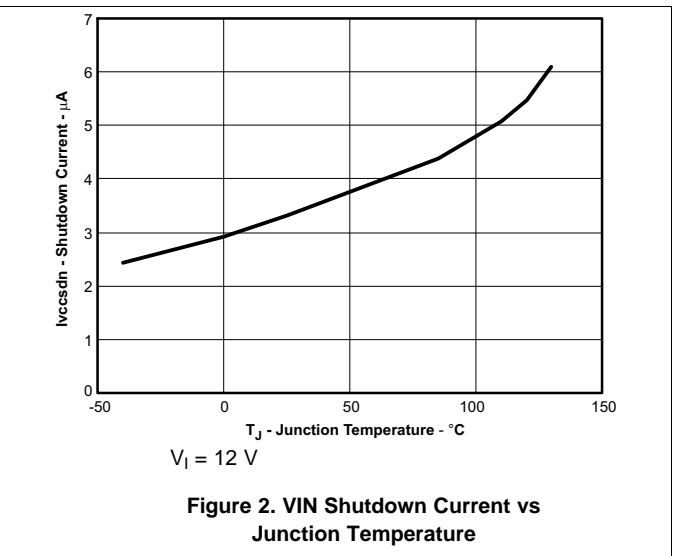
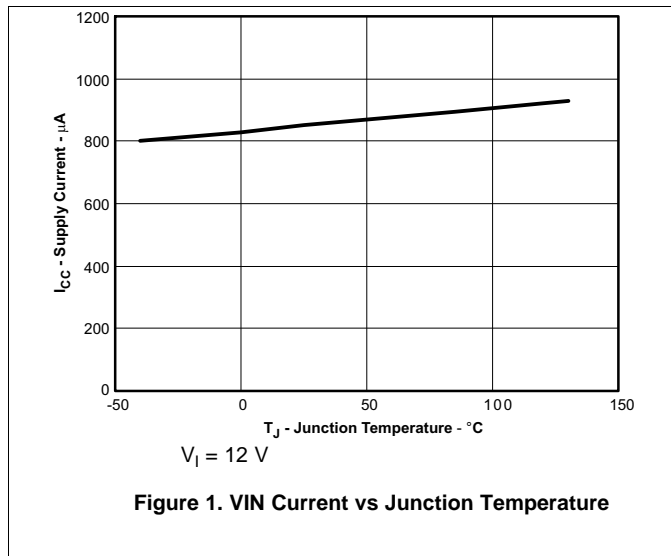

Typical Characteristics (continued)

V_{IN} = 12 V, T_A = 25°C (unless otherwise noted).

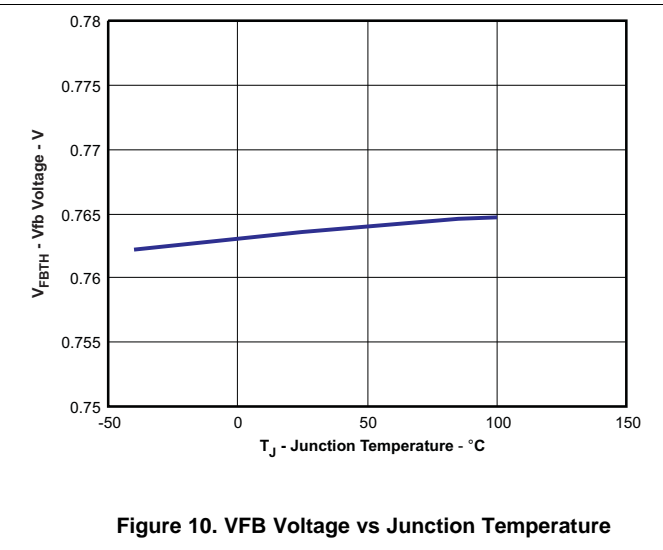
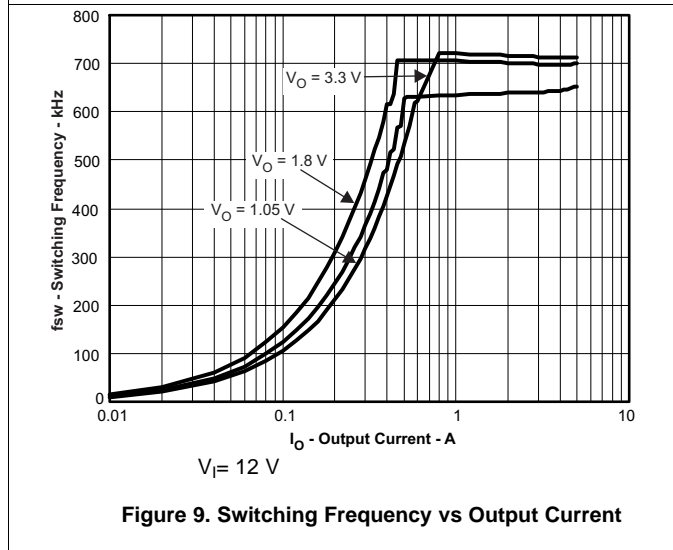
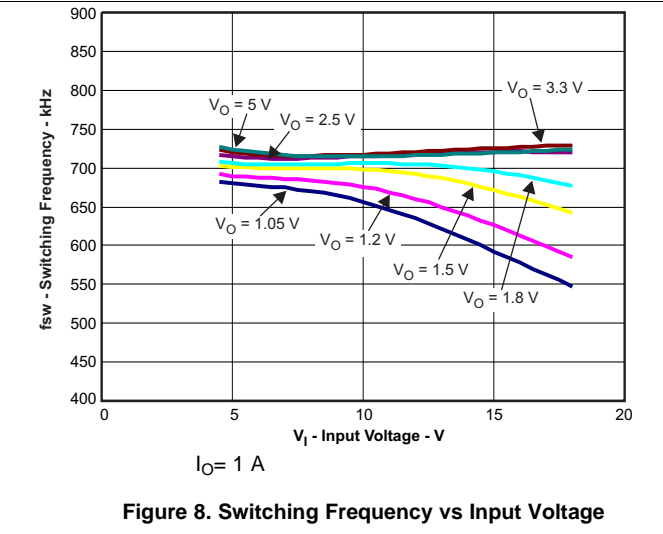
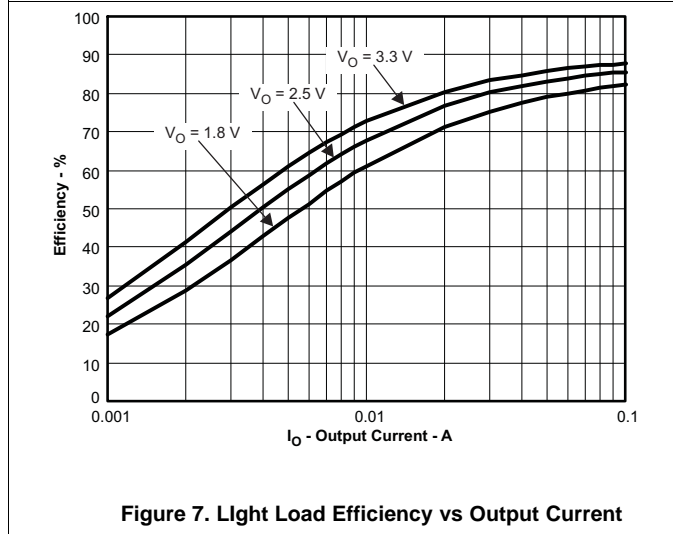
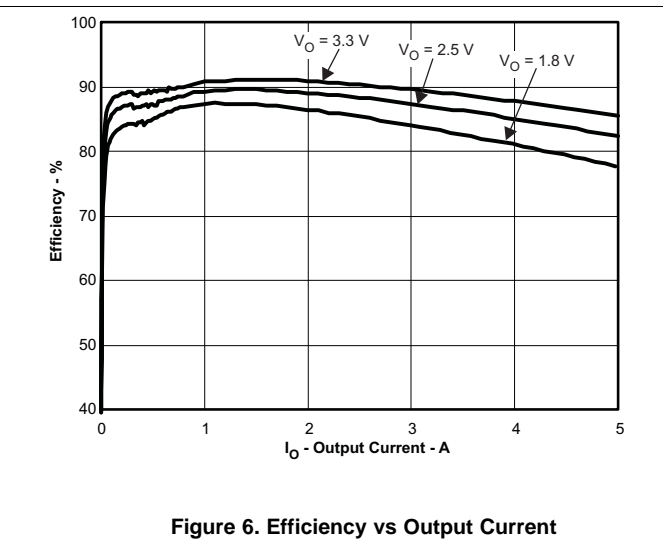
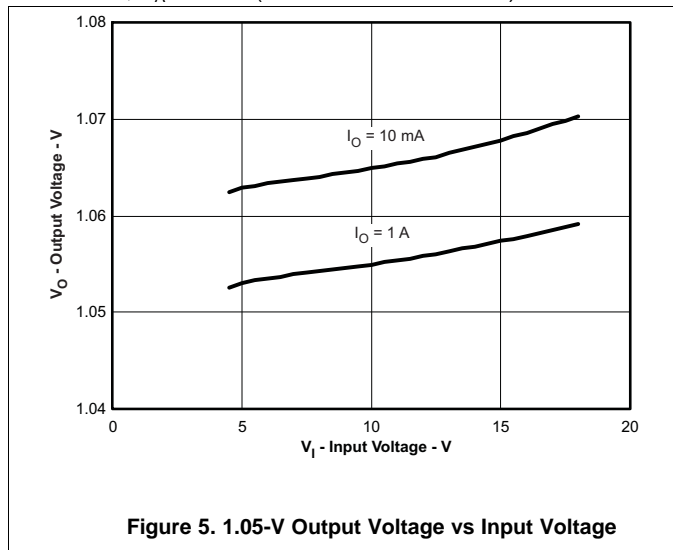

Typical Characteristics (continued)

V_{IN} = 12 V, T_A = 25°C (unless otherwise noted).

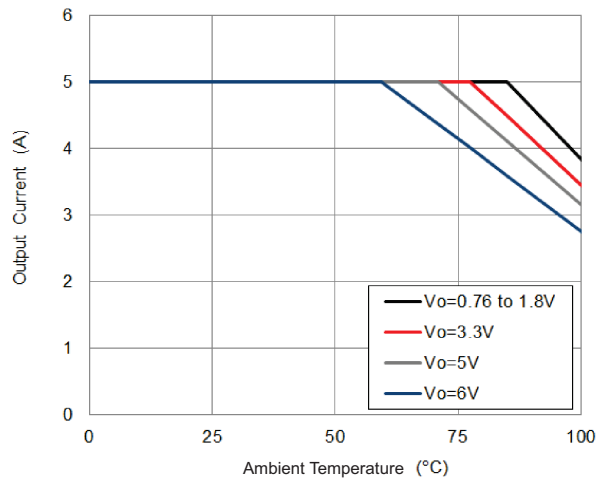

Figure 11. Maximum Power Dissipation

8 Detailed Description

8.1 Overview

The TPS54528 is a 5-A synchronous step-down (buck) converter with two integrated N-channel MOSFETs. It operates using D-CAP2™ mode control. The fast transient response of D-CAP2™ control reduces the output capacitance required to meet a specific level of performance. Proprietary internal circuitry allows the use of low ESR output capacitors including ceramic and special polymer types.

8.2 Functional Block Diagram

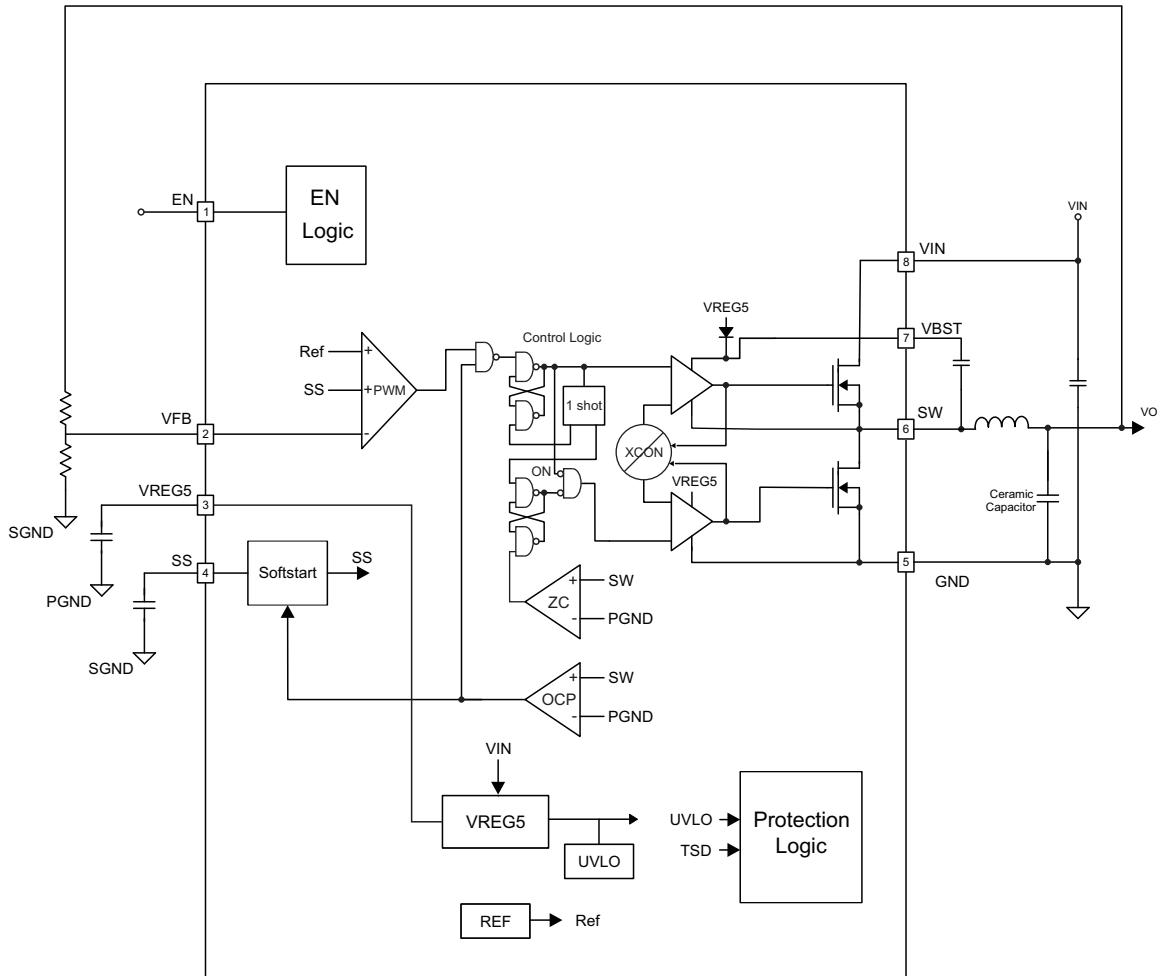

8.3 Feature Description

8.3.1 Soft Start And Pre-Biased Soft Start

The soft start function is adjustable. When the EN terminal becomes high, 6µA current begins charging the capacitor which is connected from the SS terminal to GND. Smooth control of the output voltage is maintained during start up. The equation for the slow start time is shown in Equation 1. VFB voltage is 0.765 V and SS terminal source current is 6µA.

$$t_{ss}(\text{ms}) = \frac{C6(\text{nF}) \times V_{FB} \times 1.1}{I_{SS}(\mu\text{A})} = \frac{C6(\text{nF}) \times 0.765 \times 1.1}{6} \quad (1)$$

Feature Description (continued)

The TPS54528 contains a unique circuit to prevent current from being pulled from the output during startup if the output is pre-biased. When the soft-start commands a voltage higher than the pre-bias level (internal soft start becomes greater than feedback voltage V_{FB}), the controller slowly activates synchronous rectification by starting the first low side FET gate driver pulses with a narrow on-time. It then increments that on-time on a cycle-by-cycle basis until it coincides with the time dictated by $(1-D)$, where D is the duty cycle of the converter. This scheme prevents the initial sinking of the pre-bias output, and ensure that the out voltage (V_O) starts and ramps up smoothly into regulation and the control loop is given time to transition from pre-biased start-up to normal mode operation.

8.3.2 Current Protection

The output overcurrent protection (OCP) is implemented using a cycle-by-cycle valley detect control circuit. The switch current is monitored by measuring the low-side FET switch voltage between the SW terminal and GND. This voltage is proportional to the switch current. To improve accuracy, the voltage sensing is temperature compensated.

During the on time of the high-side FET switch, the switch current increases at a linear rate determined by V_{IN} , V_{OUT} , the on-time and the output inductor value. During the on time of the low-side FET switch, this current decreases linearly. The average value of the switch current is the load current I_{OUT} . The TPS54528 constantly monitors the low-side FET switch voltage, which is proportional to the switch current, during the low-side on-time. If the measured voltage is above the voltage proportional to the current limit, an internal counter is incremented per each SW cycle and the converter maintains the low-side switch on until the measured voltage is below the voltage corresponding to the current limit at which time the switching cycle is terminated and a new switching cycle begins. In subsequent switching cycles, the on-time is set to a fixed value and the current is monitored in the same manner. If the over current condition exists for 7 consecutive switching cycles, the internal OCL threshold is set to a lower level, reducing the available output current. When a switching cycle occurs where the switch current is not above the lower OCL threshold, the counter is reset and the OCL limit is returned to the higher value.

There are some important considerations for this type of over-current protection. The peak current is the average load current plus one half of the peak-to-peak inductor current. The valley current is the average load current minus one half of the peak-to-peak inductor current. Since the valley current is used to detect the overcurrent threshold, the load current is higher than the over-current threshold. Also, when the current is being limited, the output voltage tends to fall as the demanded load current may be higher than the current available from the converter. When the over current condition is removed, the output voltage will return to the regulated value. This protection is non-latching.

8.3.3 UVLO Protection

Undervoltage lock out protection (UVLO) monitors the voltage of the V_{REG5} terminal. When the V_{REG5} voltage is lower than UVLO threshold voltage, the TPS54528 is shut off. This protection is non-latching.

8.3.4 Thermal Shutdown

TPS54528 monitors the temperature of itself. If the temperature exceeds the threshold value (typically 165°C), the device is shut off. This is non-latch protection.

8.4 Device Functional Modes

8.4.1 PWM Operation

The main control loop of the TPS54528 is an adaptive on-time pulse width modulation (PWM) controller that supports a proprietary D-CAP2™ mode control. D-CAP2™ mode control combines constant on-time control with an internal compensation circuit for pseudo-fixed frequency and low external component count configuration with both low ESR and ceramic output capacitors. It is stable even with virtually no ripple at the output.

Device Functional Modes (continued)

At the beginning of each cycle, the high-side MOSFET is turned on. This MOSFET is turned off after internal one shot timer expires. This one shot is set by the converter input voltage, V_{IN} , and the output voltage, V_O , to maintain a pseudo-fixed frequency over the input voltage range, hence it is called adaptive on-time control. The one-shot timer is reset and the high-side MOSFET is turned on again when the feedback voltage falls below the reference voltage. An internal ramp is added to reference voltage to simulate output ripple, eliminating the need for ESR induced output ripple from D-CAP2™ mode control.

8.4.2 PWM Frequency And Adaptive On-Time Control

TPS54528 uses an adaptive on-time control scheme and does not have a dedicated on board oscillator. The TPS54528 runs with a pseudo-constant frequency of 700 kHz by using the input voltage and output voltage to set the on-time one-shot timer. The on-time is inversely proportional to the input voltage and proportional to the output voltage; therefore, when the duty ratio is V_{OUT}/V_{IN} , the frequency is constant.

8.4.3 Auto-Skip Eco-Mode™ Control

The TPS54528 is designed with Auto-Skip Eco-mode™ to increase light load efficiency. As the output current decreases from heavy load condition, the inductor current is also reduced and eventually comes to point that its rippled valley touches zero level, which is the boundary between continuous conduction and discontinuous conduction modes. The rectifying MOSFET is turned off when its zero inductor current is detected. As the load current further decreases the converter run into discontinuous conduction mode. The on-time is kept almost the same as is was in the continuous conduction mode so that it takes longer time to discharge the output capacitor with smaller load current to the level of the reference voltage. The transition point to the light load operation $I_{OUT(LL)}$ current can be calculated in [Equation 2](#)

$$I_{OUT(LL)} = \frac{1}{2 \cdot L \cdot f_{sw}} \cdot \frac{(V_{IN} - V_{OUT}) \cdot V_{OUT}}{V_{IN}} \quad (2)$$

9 Applications and Implementation

9.1 Application Information

The TPS54528 is designed to provide up to a 2-A output current from an input voltage source ranging from 4.5 V to 18 V. The output voltage is configurable from 0.76 V to 6 V. A simplified design procedure for a 1.05-V output is shown below.

9.2 Typical Application

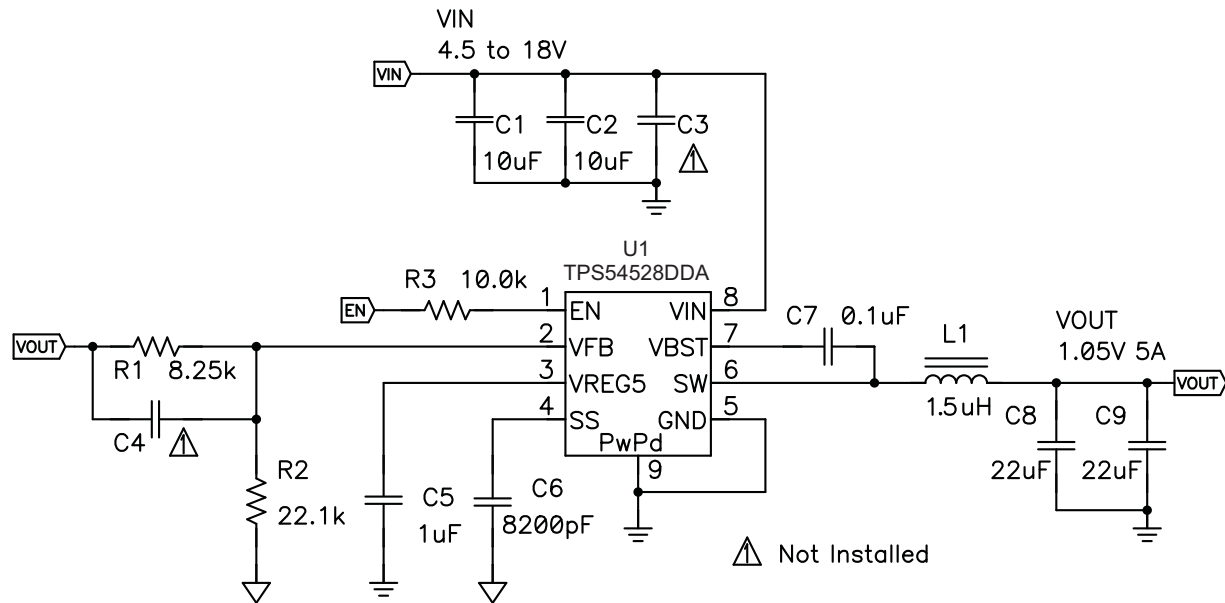

Figure 12. 5-A Synchronous Step-Down (Buck) Converter

9.2.1 Design Requirements

Figure 12 shows the schematic of the design example.

To begin the design process, the user must know a few application parameters:

- Input voltage range
- Output voltage
- Output current
- Output voltage ripple
- Input voltage ripple

9.2.2 Detailed Design Procedure

9.2.2.1 Output Voltage Resistors Selection

The output voltage is set with a resistor divider from the output node to the VFB terminal. It is recommended to use 1% tolerance or better divider resistors. Start by using Equation 3 to calculate V_{OUT} .

To improve efficiency at light loads consider using larger value resistors, high resistance is more susceptible to noise, and the voltage errors from the VFB input current are more noticeable.

$$V_{OUT} = 0.765 \times \left(1 + \frac{R1}{R2} \right) \quad (3)$$

Typical Application (continued)

9.2.2.2 Output Filter Selection

The output filter used with the TPS54528 is an LC circuit. This LC filter has double pole at:

$$F_P = \frac{1}{2\pi\sqrt{L_{OUT} \times C_{OUT}}} \quad (4)$$

At low frequencies, the overall loop gain is set by the output set-point resistor divider network and the internal gain of the TPS54528. The low frequency phase is 180 degrees. At the output filter pole frequency, the gain rolls off at a –40 dB per decade rate and the phase drops rapidly. D-CAP2™ introduces a high frequency zero that reduces the gain roll off to –20 dB per decade and increases the phase to 90 degrees one decade above the zero frequency. The inductor and capacitor selected for the output filter must be selected so that the double pole of Equation 4 is located below the high frequency zero but close enough that the phase boost provided by the high frequency zero provides adequate phase margin for a stable circuit. To meet this requirement use the values recommended in Table 1.

Table 1. Recommended Component Values

Output Voltage (V)	R1 (kΩ)	R2 (kΩ)	C4 (pF) ⁽¹⁾	L1 (μH)	C8 + C9 (μF)
1	6.81	22.1		1.0 - 1.5	22 - 68
1.05	8.25	22.1		1.0 - 1.5	22 - 68
1.2	12.7	22.1		1.0 - 1.5	22 - 68
1.5	21.5	22.1		1.5	22 - 68
1.8	30.1	22.1	5 - 22	1.5	22 - 68
2.5	49.9	22.1	5 - 22	2.2	22 - 68
3.3	73.2	22.1	5 - 22	2.2	22 - 68
5	124	22.1	5 - 22	3.3	22 - 68

(1) Optional

Since the DC gain is dependent on the output voltage, the required inductor value increases as the output voltage increases. For higher output voltages at or above 1.8 V, additional phase boost can be achieved by adding a feed forward capacitor (C4) in parallel with R1

The inductor peak-to-peak ripple current, peak current and RMS current are calculated using Equation 5, Equation 6 and Equation 7. The inductor saturation current rating must be greater than the calculated peak current and the RMS or heating current rating must be greater than the calculated RMS current. Use 700 kHz for f_{SW} .

Use 650 kHz for f_{SW} . Make sure the chosen inductor is rated for the peak current of Equation 6 and the RMS current of Equation 7.

$$I_{IPP} = \frac{V_{OUT}}{V_{IN(max)}} \times \frac{V_{IN(max)} - V_{OUT}}{L_O \times f_{SW}} \quad (5)$$

$$I_{Ipeak} = I_O + \frac{I_{IPP}}{2} \quad (6)$$

$$I_{Lo(RMS)} = \sqrt{I_O^2 + \frac{1}{12} I_{IPP}^2} \quad (7)$$

For this design example, the calculated peak current is 5.51 A and the calculated RMS current is 5.01 A. The inductor used is a TDK SPM6530-1R5M100 with a peak current rating of 11.5 A and an RMS current rating of 11 A.

The capacitor value and ESR determines the amount of output voltage ripple. The TPS54528 is intended for use with ceramic or other low ESR capacitors. Recommended values range from 22μF to 68μF. Use Equation 8 to determine the required RMS current rating for the output capacitor.

$$I_{Co(RMS)} = \frac{V_{OUT} \times (V_{IN} - V_{OUT})}{\sqrt{12} \times V_{IN} \times L_O \times f_{SW}} \quad (8)$$

For this design two TDK C3216X5R0J226M 22 μ F output capacitors are used. The typical ESR is 2 m Ω each. The calculated RMS current is 0.29 A and each output capacitor is rated for 4A.

9.2.2.3 Input Capacitor Selection

The TPS54528 requires an input decoupling capacitor and a bulk capacitor is needed depending on the application. A ceramic capacitor over 10 μ F is recommended for the decoupling capacitor. An additional 0.1 μ F capacitor (C3) from terminal 8 to ground is optional to provide additional high frequency filtering. The capacitor voltage rating needs to be greater than the maximum input voltage.

9.2.2.4 Bootstrap Capacitor Selection

A 0.1 μ F ceramic capacitor must be connected between the VBST to SW terminal for proper operation. It is recommended to use a ceramic capacitor.

9.2.2.5 Vreg5 Capacitor Selection

A 1- μ F ceramic capacitor must be connected between the VREG5 to GND terminal for proper operation. It is recommended to use a ceramic capacitor.

9.2.3 Application Performance Curves

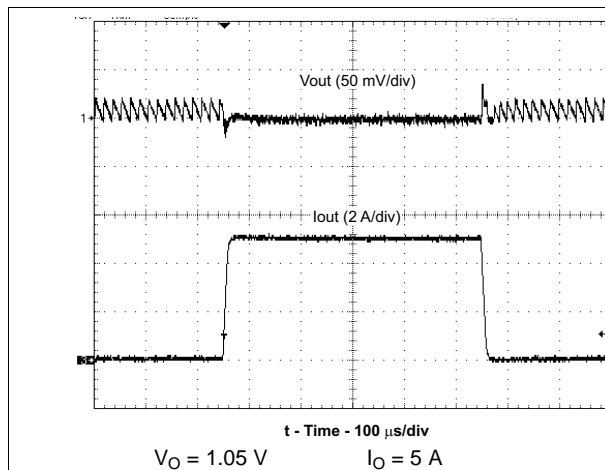

Figure 13. Load Transient Response

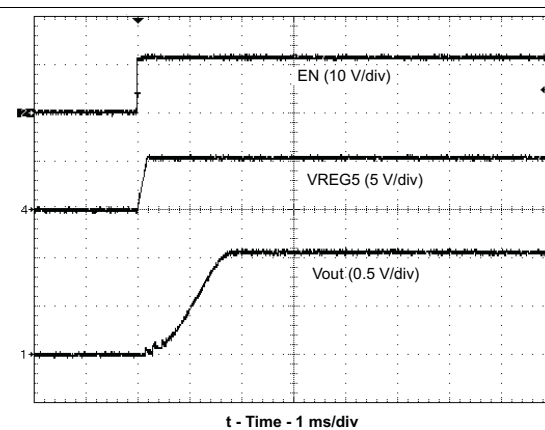

Figure 14. Start-Up Wave Form

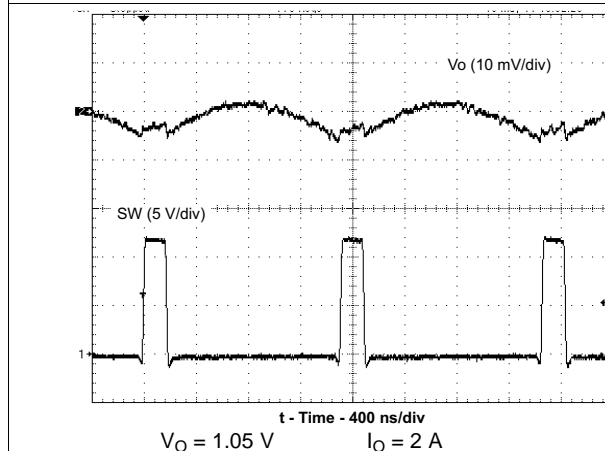

Figure 15. Voltage Ripple At Output

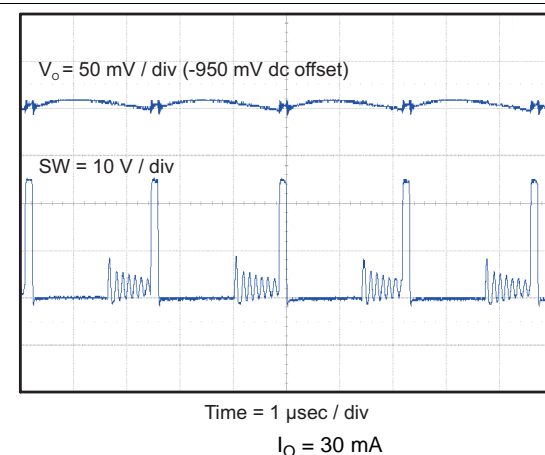

Figure 16. DCM Voltage Ripple At Output

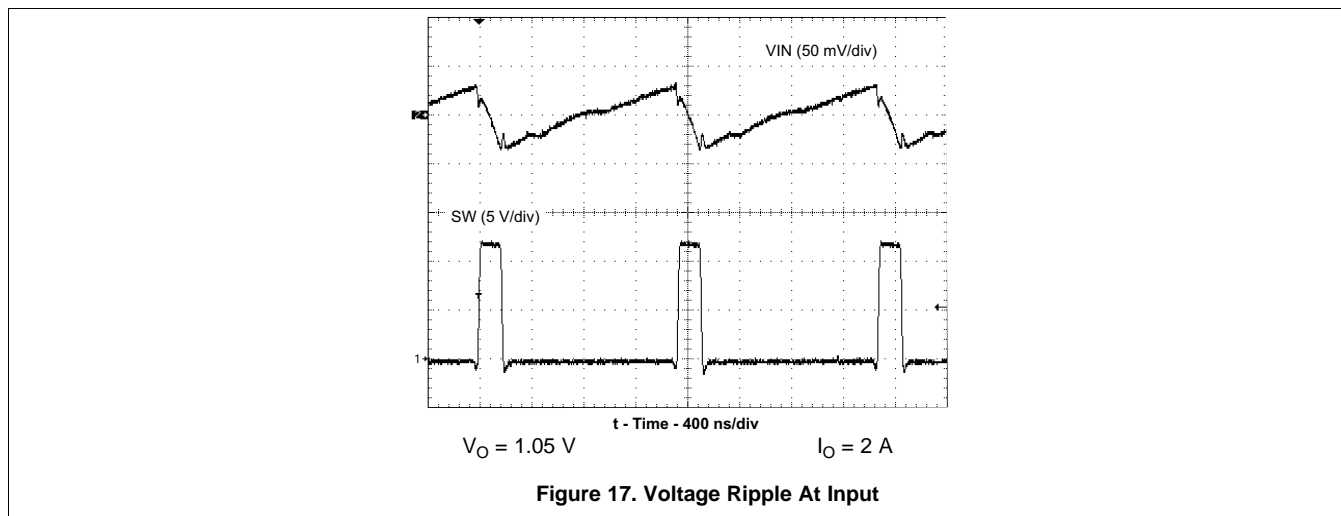

Figure 17. Voltage Ripple At Input

10 Power Supply Recommendations

The input voltage range is from 4.5V to 18V. The input power supply and the input capacitors should be located as close to the device as possible to minimize the impedance of the power-supply line.

11 Layout

11.1 Layout Guidelines

1. The TPS54528 can supply large load currents up to 5 A, so heat dissipation may be a concern. The top side area adjacent to the TPS54528 should be filled with ground as much as possible to dissipate heat.
2. The bottom side area directly below the IC should have a dedicated ground area. It should be directly connected to the thermal pad of the device using vias as shown. The ground area should be as large as practical. Additional internal layers can be dedicated as ground planes and connected to the vias as well.
3. Keep the input switching current loop as small as possible.
4. Keep the SW node as physically small and short as possible to minimize parasitic capacitance and inductance and to minimize radiated emissions. Kelvin connections should be brought from the output to the feedback terminal of the device.
5. Keep analog and non-switching components away from switching components.
6. Make a single point connection from the signal ground to power ground.
7. Do not allow switching current to flow under the device.
8. Keep the pattern lines for VIN and PGND broad.
9. Exposed pad of device must be connected to PGND with solder.
10. VREG5 capacitor should be placed near the device, and connected to PGND.
11. Output capacitor should be connected to a broad pattern of the PGND.
12. Voltage feedback loop should be as short as possible, and preferably with ground shield.
13. Lower resistor of the voltage divider which is connected to the VFB terminal should be tied to SGND.
14. Providing sufficient via is preferable for VIN, SW and PGND connection.
15. PCB pattern for VIN, SW, and PGND should be as broad as possible.
16. VIN Capacitor should be placed as near as possible to the device.

11.2 Layout Example

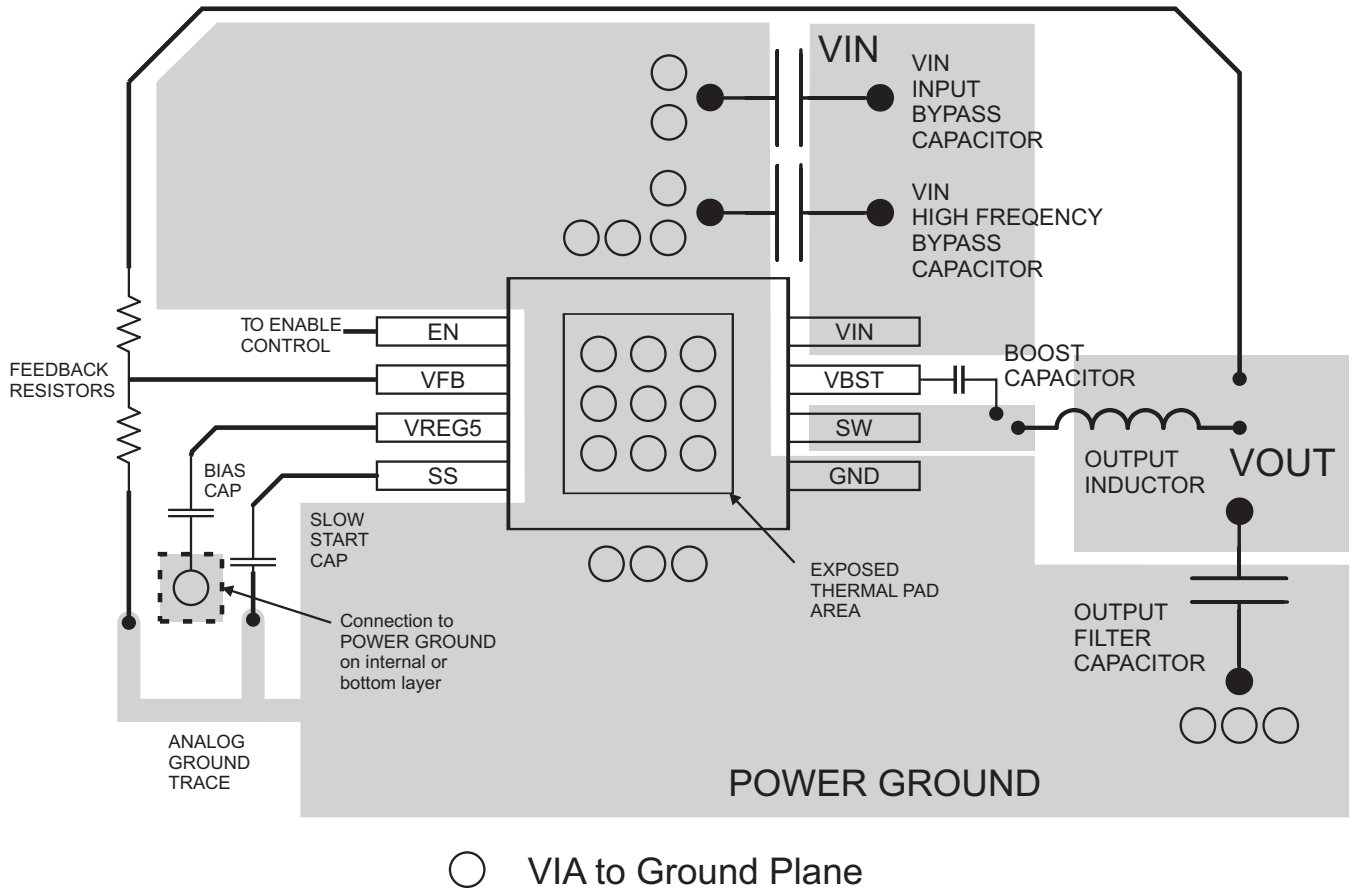

11.3 Thermal Information

This 8-terminal DDA package incorporates an exposed thermal pad that is designed to be directly connected to an external heatsink. The thermal pad must be soldered directly to the printed board (PCB). After soldering, the PCB can be used as a heatsink. In addition, through the use of thermal vias, the thermal pad can be attached directly to the appropriate copper plane shown in the electrical schematic for the device, or alternatively, can be attached to a special heatsink structure designed into the PCB. This design optimizes the heat transfer from the integrated circuit (IC).

For additional information on the exposed thermal pad and how to use the advantage of its heat dissipating abilities, see the Technical Brief, *PowerPAD™ Thermally Enhanced Package*, Texas Instruments Literature No. [SLMA002](#) and Application Brief, *PowerPAD™ Made Easy*, Texas Instruments Literature No. [SLMA004](#).

The exposed thermal pad dimensions for this package are shown in the following illustration.

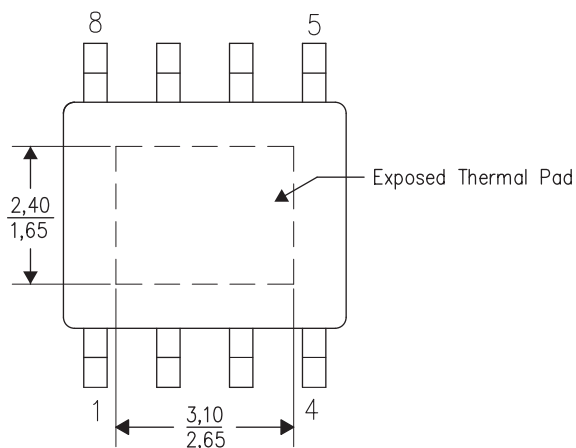

Figure 18. Thermal Pad Dimensions

12 Device and Documentation Support

12.1 Documentation Support

12.1.1 Related Documentation

D-CAP2™ Frequency Response Model, [SLVA546](#)

TPS54528EVM-052, 5-A, SWIFT™ Regulator Evaluation Module, [SLVU480](#)

12.2 Trademarks

D-CAP2, Eco-mode are trademarks of Texas Instruments.

Blu-ray Disc is a trademark of Blu-ray Disc Association.

12.3 Electrostatic Discharge Caution



These devices have limited built-in ESD protection. The leads should be shorted together or the device placed in conductive foam during storage or handling to prevent electrostatic damage to the MOS gates.

12.4 Glossary

[SLYZ022](#) — *TI Glossary*.

This glossary lists and explains terms, acronyms and definitions.

13 Mechanical, Packaging, and Orderable Information

The following pages include mechanical packaging and orderable information. This information is the most current data available for the designated devices. This data is subject to change without notice and revision of this document. For browser-based versions of this data sheet, refer to the left-hand navigation.

PACKAGING INFORMATION

Orderable Device	Status (1)	Package Type	Package Drawing	Pins	Package Qty	Eco Plan (2)	Lead/Ball Finish (6)	MSL Peak Temp (3)	Op Temp (°C)	Device Marking (4/5)	Samples
HPA01123DDAR	ACTIVE	SO PowerPAD	DDA	8	2500	Green (RoHS & no Sb/Br)	CU NIPDAU	Level-2-260C-1 YEAR	-40 to 85	54528	Samples
TPS54528DDA	ACTIVE	SO PowerPAD	DDA	8	75	Green (RoHS & no Sb/Br)	CU NIPDAU CU SN	Level-2-260C-1 YEAR	-40 to 85	54528	Samples
TPS54528DDAR	ACTIVE	SO PowerPAD	DDA	8	2500	Green (RoHS & no Sb/Br)	CU NIPDAU CU SN	Level-2-260C-1 YEAR	-40 to 85	54528	Samples

(1) The marketing status values are defined as follows:

ACTIVE: Product device recommended for new designs.

LIFEBUY: TI has announced that the device will be discontinued, and a lifetime-buy period is in effect.

NRND: Not recommended for new designs. Device is in production to support existing customers, but TI does not recommend using this part in a new design.

PREVIEW: Device has been announced but is not in production. Samples may or may not be available.

OBsolete: TI has discontinued the production of the device.

(2) Eco Plan - The planned eco-friendly classification: Pb-Free (RoHS), Pb-Free (RoHS Exempt), or Green (RoHS & no Sb/Br) - please check <http://www.ti.com/productcontent> for the latest availability information and additional product content details.

TBD: The Pb-Free/Green conversion plan has not been defined.

Pb-Free (RoHS): TI's terms "Lead-Free" or "Pb-Free" mean semiconductor products that are compatible with the current RoHS requirements for all 6 substances, including the requirement that lead not exceed 0.1% by weight in homogeneous materials. Where designed to be soldered at high temperatures, TI Pb-Free products are suitable for use in specified lead-free processes.

Pb-Free (RoHS Exempt): This component has a RoHS exemption for either 1) lead-based flip-chip solder bumps used between the die and package, or 2) lead-based die adhesive used between the die and leadframe. The component is otherwise considered Pb-Free (RoHS compatible) as defined above.

Green (RoHS & no Sb/Br): TI defines "Green" to mean Pb-Free (RoHS compatible), and free of Bromine (Br) and Antimony (Sb) based flame retardants (Br or Sb do not exceed 0.1% by weight in homogeneous material)

(3) MSL, Peak Temp. - The Moisture Sensitivity Level rating according to the JEDEC industry standard classifications, and peak solder temperature.

(4) There may be additional marking, which relates to the logo, the lot trace code information, or the environmental category on the device.

(5) Multiple Device Markings will be inside parentheses. Only one Device Marking contained in parentheses and separated by a "~" will appear on a device. If a line is indented then it is a continuation of the previous line and the two combined represent the entire Device Marking for that device.

(6) Lead/Ball Finish - Orderable Devices may have multiple material finish options. Finish options are separated by a vertical ruled line. Lead/Ball Finish values may wrap to two lines if the finish value exceeds the maximum column width.

Important Information and Disclaimer: The information provided on this page represents TI's knowledge and belief as of the date that it is provided. TI bases its knowledge and belief on information provided by third parties, and makes no representation or warranty as to the accuracy of such information. Efforts are underway to better integrate information from third parties. TI has taken and

continues to take reasonable steps to provide representative and accurate information but may not have conducted destructive testing or chemical analysis on incoming materials and chemicals. TI and TI suppliers consider certain information to be proprietary, and thus CAS numbers and other limited information may not be available for release.

In no event shall TI's liability arising out of such information exceed the total purchase price of the TI part(s) at issue in this document sold by TI to Customer on an annual basis.

TAPE AND REEL INFORMATION

QUADRANT ASSIGNMENTS FOR PIN 1 ORIENTATION IN TAPE



*All dimensions are nominal

Device	Package Type	Package Drawing	Pins	SPQ	Reel Diameter (mm)	Reel Width W1 (mm)	A0 (mm)	B0 (mm)	K0 (mm)	P1 (mm)	W (mm)	Pin1 Quadrant
TPS54528DDAR	SO Power PAD	DDA	8	2500	330.0	12.8	6.4	5.2	2.1	8.0	12.0	Q1

TAPE AND REEL BOX DIMENSIONS

*All dimensions are nominal

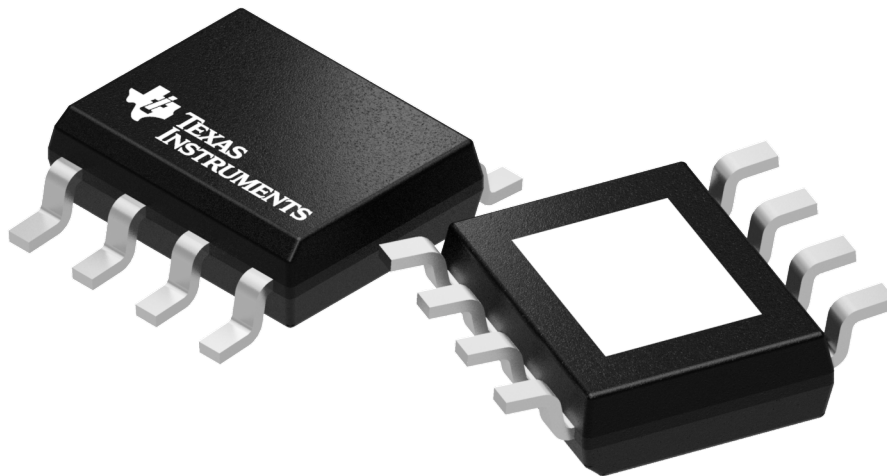
Device	Package Type	Package Drawing	Pins	SPQ	Length (mm)	Width (mm)	Height (mm)
TPS54528DDAR	SO PowerPAD	DDA	8	2500	366.0	364.0	50.0



Images above are just a representation of the package family, actual package may vary.
Refer to the product data sheet for package details.

DDA (R-PDSO-G8)

PowerPAD™ PLASTIC SMALL-OUTLINE

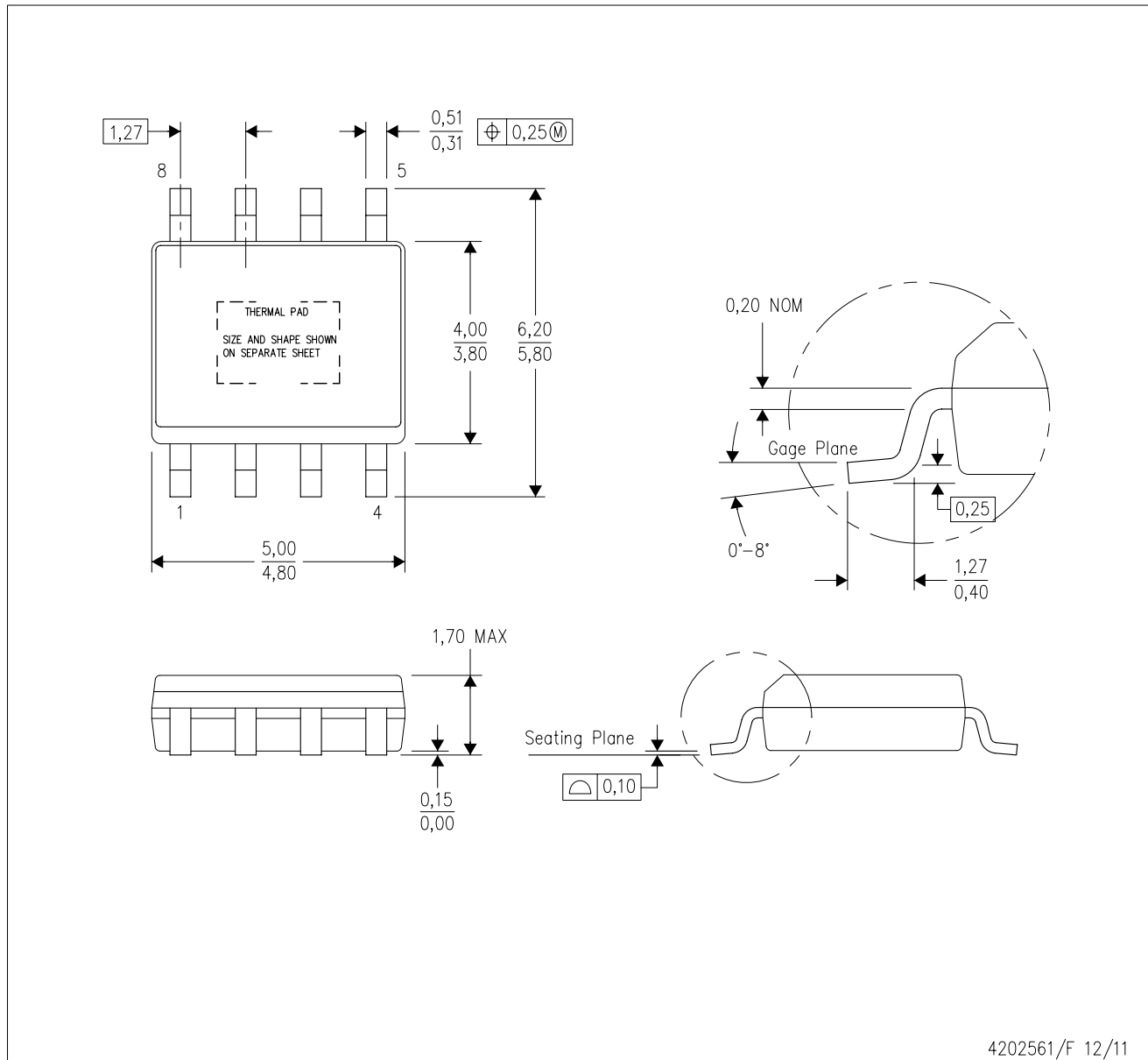

- NOTES:
- All linear dimensions are in millimeters. Dimensioning and tolerancing per ASME Y14.5-1994.
 - This drawing is subject to change without notice.
 - Body dimensions do not include mold flash or protrusion not to exceed 0,15.
 - This package is designed to be soldered to a thermal pad on the board. Refer to Technical Brief, PowerPad Thermally Enhanced Package, Texas Instruments Literature No. SLMA002 for information regarding recommended board layout. This document is available at www.ti.com <<http://www.ti.com>>.
 - See the additional figure in the Product Data Sheet for details regarding the exposed thermal pad features and dimensions.
 - This package complies to JEDEC MS-012 variation BA

PowerPAD is a trademark of Texas Instruments.

DDA (R-PDSO-G8)

PowerPAD™ PLASTIC SMALL OUTLINE

THERMAL INFORMATION

This PowerPAD™ package incorporates an exposed thermal pad that is designed to be attached to a printed circuit board (PCB). The thermal pad must be soldered directly to the PCB. After soldering, the PCB can be used as a heatsink. In addition, through the use of thermal vias, the thermal pad can be attached directly to the appropriate copper plane shown in the electrical schematic for the device, or alternatively, can be attached to a special heatsink structure designed into the PCB. This design optimizes the heat transfer from the integrated circuit (IC).

For additional information on the PowerPAD package and how to take advantage of its heat dissipating abilities, refer to Technical Brief, PowerPAD Thermally Enhanced Package, Texas Instruments Literature No. SLMA002 and Application Brief, PowerPAD Made Easy, Texas Instruments Literature No. SLMA004. Both documents are available at www.ti.com.

The exposed thermal pad dimensions for this package are shown in the following illustration.

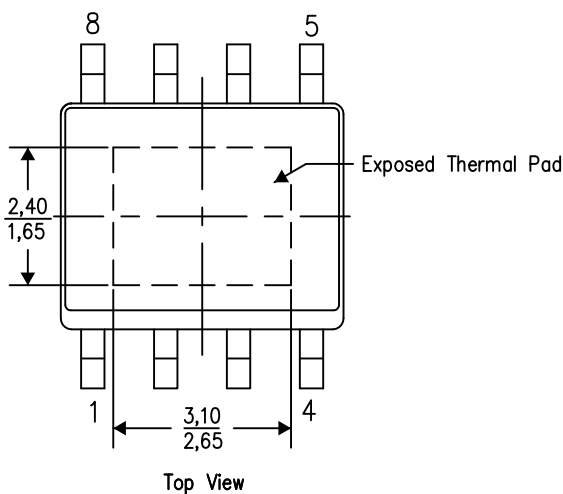

Exposed Thermal Pad Dimensions

4206322-6/L 05/12

NOTE: A. All linear dimensions are in millimeters

PowerPAD is a trademark of Texas Instruments

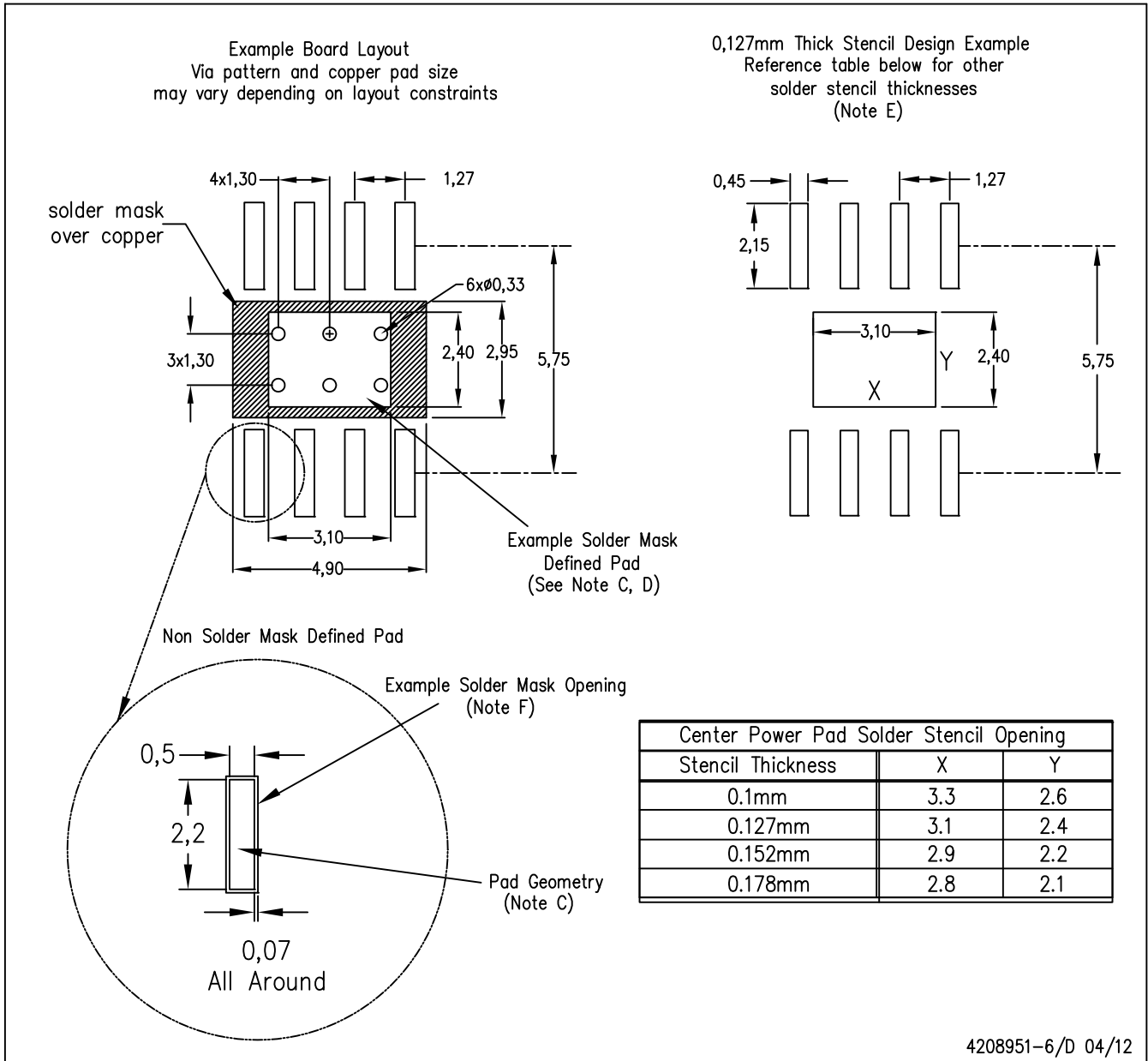

- NOTES:
- A. All linear dimensions are in millimeters.
 - B. This drawing is subject to change without notice.
 - C. Publication IPC-7351 is recommended for alternate designs.
 - D. This package is designed to be soldered to a thermal pad on the board. Refer to Technical Brief, PowerPad Thermally Enhanced Package, Texas Instruments Literature No. SLMA002, SLMA004, and also the Product Data Sheets for specific thermal information, via requirements, and recommended board layout. These documents are available at www.ti.com <<http://www.ti.com>>. Publication IPC-7351 is recommended for alternate designs.
 - E. Laser cutting apertures with trapezoidal walls and also rounding corners will offer better paste release. Customers should contact their board assembly site for stencil design recommendations. Example stencil design based on a 50% volumetric metal load solder paste. Refer to IPC-7525 for other stencil recommendations.
 - F. Customers should contact their board fabrication site for solder mask tolerances between and around signal pads.

PowerPAD is a trademark of Texas Instruments.

IMPORTANT NOTICE AND DISCLAIMER

TI PROVIDES TECHNICAL AND RELIABILITY DATA (INCLUDING DATASHEETS), DESIGN RESOURCES (INCLUDING REFERENCE DESIGNS), APPLICATION OR OTHER DESIGN ADVICE, WEB TOOLS, SAFETY INFORMATION, AND OTHER RESOURCES "AS IS" AND WITH ALL FAULTS, AND DISCLAIMS ALL WARRANTIES, EXPRESS AND IMPLIED, INCLUDING WITHOUT LIMITATION ANY IMPLIED WARRANTIES OF MERCHANTABILITY, FITNESS FOR A PARTICULAR PURPOSE OR NON-INFRINGEMENT OF THIRD PARTY INTELLECTUAL PROPERTY RIGHTS.

These resources are intended for skilled developers designing with TI products. You are solely responsible for (1) selecting the appropriate TI products for your application, (2) designing, validating and testing your application, and (3) ensuring your application meets applicable standards, and any other safety, security, or other requirements. These resources are subject to change without notice. TI grants you permission to use these resources only for development of an application that uses the TI products described in the resource. Other reproduction and display of these resources is prohibited. No license is granted to any other TI intellectual property right or to any third party intellectual property right. TI disclaims responsibility for, and you will fully indemnify TI and its representatives against, any claims, damages, costs, losses, and liabilities arising out of your use of these resources.

TI's products are provided subject to TI's Terms of Sale (www.ti.com/legal/termsofsale.html) or other applicable terms available either on ti.com or provided in conjunction with such TI products. TI's provision of these resources does not expand or otherwise alter TI's applicable warranties or warranty disclaimers for TI products.

Mailing Address: Texas Instruments, Post Office Box 655303, Dallas, Texas 75265
Copyright © 2019, Texas Instruments Incorporated

Looking for pricing, stock, or lifecycle information?

Click below to explore more details on WIN SOURCE:

 [View TPS54528DDA on WIN SOURCE](#)

 [Texas Instruments](#) Information

Optimize Your Supply Chain with WIN SOURCE Solutions

-  Global Sourcing Solution
-  Obsolete Management
-  Cost Control Management
-  Shortage Management
-  Alternative Solution
-  Excess Inventory Management