



**THE DATASHEET OF  
TPS54531DDAR**



# TPS54531 5-A, 28-V Input, SWIFT™ Step-Down Converter With Eco-mode

## 1 Features

- 3.5 to 28-V input voltage range
- Adjustable output voltage down to 0.8 V
- Integrated 80-mΩ high-side MOSFET supports up to 5-A continuous output current
- High efficiency at light loads with a pulse skipping Eco-mode
- Fixed 570-kHz switching frequency
- Typical 1-μA shutdown quiescent current
- Adjustable slow start limits inrush currents
- Programmable UVLO threshold
- Overvoltage transient protection
- Cycle-by-cycle current-limit, frequency fold back, and thermal shutdown protection
- Available in easy-to-use thermally enhanced 8-pin SO PowerPAD™ integrated circuit package
- Use [TPS56637](#) for higher efficiency in a smaller package
- Create a custom design using the TPS54531 with the [WEBENCH® Power Designer](#)

## 2 Applications

- Consumer applications such as set-top boxes, CPE equipment, LCD displays, peripherals, and battery chargers
- Industrial and car audio power supplies
- 5-V, 12-V and 24-V distributed power systems

## 3 Description

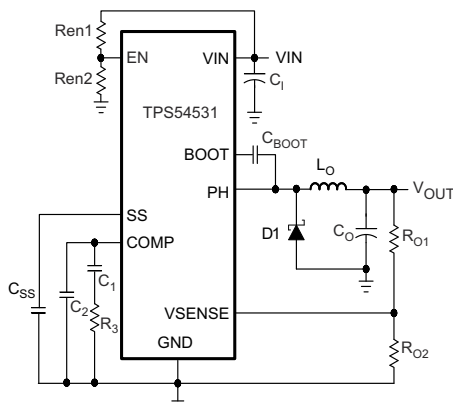
The TPS54531 device is a 28-V, 5-A non-synchronous buck converter that integrates a low

$R_{DS(on)}$  high-side MOSFET. To increase efficiency at light loads, a pulse skipping Eco-mode feature is automatically activated. Furthermore, the 1-μA shutdown supply current allows the device to be used in battery powered applications. Current mode control with internal slope compensation simplifies the external compensation calculations and reduces component count while allowing the use of ceramic output capacitors. A resistor divider programs the hysteresis of the input undervoltage lockout. An overvoltage transient protection circuit limits voltage overshoots during startup and transient conditions. A cycle-by-cycle current-limit scheme, frequency fold back, and thermal shutdown protect the device and the load in the event of an overload condition. The TPS54531 device is available in 8-pin SO PowerPAD integrated circuit package that has been internally optimized to improve thermal performance.

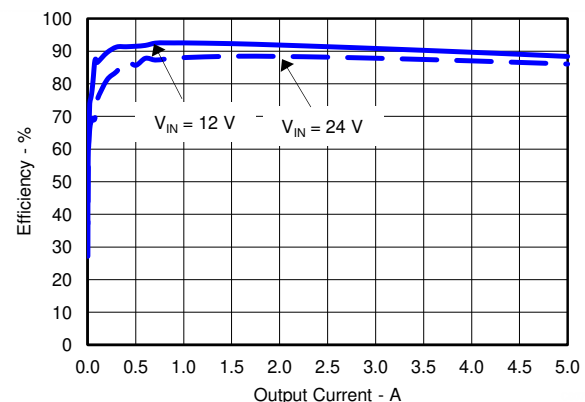
### Package Information

PART NUMBER	PACKAGE <sup>(1)</sup>	PACKAGE SIZE <sup>(2)</sup>
TPS54531	DDA (SO PowerPAD, 8)	4.9 mm × 6 mm

- (1) For all available packages, see the orderable addendum at the end of the data sheet.
- (2) The package size (length × width) is a nominal value and includes pins, where applicable.



**Simplified Schematic**



**TPS54531 Efficiency**



## Table of Contents

<b>1 Features</b> .....	1	7.4 Device Functional Modes.....	12
<b>2 Applications</b> .....	1	<b>8 Application and Implementation</b> .....	13
<b>3 Description</b> .....	1	8.1 Application Information.....	13
<b>4 Revision History</b> .....	2	8.2 Typical Application.....	13
<b>5 Pin Configuration and Functions</b> .....	3	8.3 Power Supply Recommendations.....	23
<b>6 Specifications</b> .....	4	8.4 Layout.....	23
6.1 Absolute Maximum Ratings.....	4	<b>9 Device and Documentation Support</b> .....	25
6.2 ESD Ratings.....	4	9.1 Device Support.....	25
6.3 Recommended Operating Conditions.....	4	9.2 Receiving Notification of Documentation Updates....	25
6.4 Thermal Information.....	5	9.3 Support Resources.....	25
6.5 Electrical Characteristics.....	5	9.4 Trademarks.....	25
6.6 Typical Characteristics.....	6	9.5 Electrostatic Discharge Caution.....	25
<b>7 Detailed Description</b> .....	8	9.6 Glossary.....	25
7.1 Overview.....	8	<b>10 Mechanical, Packaging, and Orderable Information</b> .....	25
7.2 Functional Block Diagram.....	9		
7.3 Feature Description.....	9		

## 4 Revision History

NOTE: Page numbers for previous revisions may differ from page numbers in the current version.

<b>Changes from Revision A (October 2014) to Revision B (October 2023)</b>	<b>Page</b>
• Updated the numbering format for tables, figures, and cross-references throughout the document.....	1
• Added TPS56637 information in the <i>Features</i> .....	1
• Changed column title from BODY SIZE to PACKAGE SIZE in the <i>Package Information</i> table.....	1
• Updated trademark information.....	1
• Added WEBENCH support description in the <i>Features</i> section.....	1
• Moved storage temperature to the <i>Absolute Maximum Ratings</i> table.....	4
• Changed table title from <i>Handling Ratings</i> to <i>ESD Ratings</i> .....	4
• Added WEBENCH design steps.....	14
• Added WEBENCH information in the <i>Development Support</i> section.....	25
<b>Changes from Revision * (May 2013) to Revision A (October 2014)</b>	<b>Page</b>
• Added the <i>Handling Ratings</i> table, <i>Feature Description</i> section, <i>Device Functional Modes</i> section, <i>Application and Implementation</i> section, <i>Power Supply Recommendations</i> section, <i>Layout</i> section, <i>Device and Documentation Support</i> section, and <i>Mechanical, Packaging, and Orderable Information</i> section .....	1
• Added equation for $I_{ripple}$ in the <i>Inductor Selection</i> section.....	15

## 5 Pin Configuration and Functions

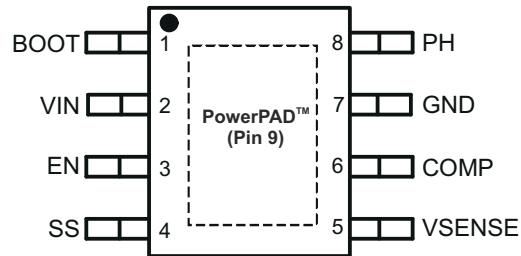


Figure 5-1. DDA Package, 8-Pin SO With PowerPAD™ Integrated Circuit Package Top View

Table 5-1. Pin Functions

PIN NO.	PIN NAME	TYPE (1)	DESCRIPTION
1	BOOT	O	A 0.1- $\mu$ F bootstrap capacitor is required between the BOOT and PH pins. If the voltage on this capacitor falls below the minimum requirement, the high-side MOSFET is forced to switch off until the capacitor is refreshed.
2	VIN	I	This pin is the 3.5- to 28-V input supply voltage.
3	EN	I	This pin is the enable pin. To disable, pull below 1.25 V. Float this pin to enable. Programming the input undervoltage lockout with two resistors is recommended.
4	SS	I	This pin is slow-start pin. An external capacitor connected to this pin sets the output rise time.
5	VSENSE	I	This pin is the inverting node of the transconductance (gm) error amplifier.
6	COMP	O	This pin is the error-amplifier output and the input to the PWM comparator. Connect frequency compensation components to this pin.
7	GND	—	Ground pin
8	PH	O	The PH pin is the source of the internal high-side power MOSFET.
9	PowerPAD integrated circuit package	—	For proper operation, the GND pin must be connected to the exposed pad.

(1) I = input, O = output

## 6 Specifications

### 6.1 Absolute Maximum Ratings

over operating free-air temperature range (unless otherwise noted)<sup>(1)</sup>

		MIN	MAX	UNIT
Input Voltage	VIN	-0.3	30	V
	EN	-0.3	6	
	BOOT		38	
	VSENSE	-0.3	3	
	COMP	-0.3	3	
	SS	-0.3	3	
Output Voltage	BOOT-PH		8	V
	PH	-0.6	30	
	PH (10 ns transient from ground to negative peak)		-5	
Source Current	EN		100	μA
	BOOT		100	mA
	VSENSE		10	μA
	PH	Current Limit		A
Sink Current	VIN	Current Limit		A
	COMP		100	μA
	SS		200	
Operating Junction Temperature		-40	150	°C
Storage temperature range		-65	150	°C

- (1) Stresses beyond those listed under absolute maximum ratings may cause permanent damage to the device. These are stress ratings only, and functional operation of the device at these or any other conditions beyond those indicated under recommended operating conditions is not implied. Exposure to absolute-maximum-rated conditions for extended periods may affect device reliability.

### 6.2 ESD Ratings

			MIN	MAX	UNIT
V <sub>(ESD)</sub>	Electrostatic discharge	Human body model (HBM), per ANSI/ESDA/JEDEC JS-001, all pins <sup>(1)</sup>	-2	2	kV
		Charged device model (CDM), per JEDEC specification JESD22-C101, all pins <sup>(2)</sup>	-1	1	

- (1) JEDEC document JEP155 states that 500-V HBM allows safe manufacturing with a standard ESD control process.  
(2) JEDEC document JEP157 states that 250-V CDM allows safe manufacturing with a standard ESD control process.

### 6.3 Recommended Operating Conditions

over operating free-air temperature range (unless otherwise noted)

		MIN	MAX	UNIT
	Operating Input Voltage on the VIN pin	3.5	28	V
T <sub>J</sub>	Operating junction temperature	-40	150	°C

## 6.4 Thermal Information

THERMAL METRIC <sup>(1)</sup>		DDA	UNIT
		8 PINS	
R <sub>θJA</sub>	Junction-to-ambient thermal resistance	55	°C/W
R <sub>θJC(top)</sub>	Junction-to-case (top) thermal resistance	63.2	
R <sub>θJB</sub>	Junction-to-board thermal resistance	31.5	
Ψ <sub>JT</sub>	Junction-to-top characterization parameter	14.9	
Ψ <sub>JB</sub>	Junction-to-board characterization parameter	31.4	
R <sub>θJC(bot)</sub>	Junction-to-case (bottom) thermal resistance	8.3	

(1) For more information about traditional and new thermal metrics, see the *IC Package Thermal Metrics* application report, [SPRA953](#).

## 6.5 Electrical Characteristics

T<sub>J</sub> = –40°C to 150°C, V<sub>IN</sub> = 3.5V to 28V (unless otherwise noted)

PARAMETER	TEST CONDITIONS	MIN	TYP	MAX	UNIT
<b>SUPPLY VOLTAGE (VIN PIN)</b>					
Internal undervoltage lockout threshold	Rising and falling			3.5	V
Shutdown supply current	EN = 0 V, V <sub>IN</sub> = 12 V, –40°C to 85°C		1	4	μA
Operating – non-switching supply current	V <sub>SENSE</sub> = 0.85 V		110	190	μA
<b>ENABLE AND UVLO (EN PIN)</b>					
Enable threshold	Rising and falling		1.25	1.35	V
Input current	Enable threshold – 50 mV		–1		μA
Input current	Enable threshold + 50 mV		–4		μA
<b>VOLTAGE REFERENCE</b>					
Voltage reference		0.772	0.8	0.828	V
<b>HIGH-SIDE MOSFET</b>					
On resistance	BOOT-PH = 3 V, V <sub>IN</sub> = 3.5 V		115	200	mΩ
	BOOT-PH = 6 V, V <sub>IN</sub> = 12 V		80	150	
<b>ERROR AMPLIFIER</b>					
Error amplifier transconductance (gm)	–2 μA < I <sub>(COMP)</sub> < 2 μA, V <sub>(COMP)</sub> = 1 V		92		μmos
Error amplifier DC gain <sup>(1)</sup>	V <sub>SENSE</sub> = 0.8 V		800		V/V
Error amplifier unity gain bandwidth <sup>(1)</sup>	5 pF capacitance from COMP to GND pins		2.7		MHz
Error amplifier source/sink current	V <sub>(COMP)</sub> = 1 V, 100-mV overdrive		±7		μA
Switch current to COMP transconductance <sup>(1)</sup>	V <sub>IN</sub> = 12 V		20		A/V
<b>SWITCHING FREQUENCY</b>					
Switching Frequency	V <sub>IN</sub> = 12 V, 25°C	456	570	684	kHz
Minimum controllable on time	V <sub>IN</sub> = 12 V, 25°C		105	130	ns
Maximum controllable duty ratio <sup>(1)</sup>	BOOT-PH = 6 V	90%	93%		
<b>PULSE SKIPPING Eco-mode</b>					
Pulse skipping Eco-mode switch current threshold			160		mA
<b>CURRENT LIMIT</b>					
Current-limit threshold	V <sub>IN</sub> = 12 V	6.3	10.5		A
<b>THERMAL SHUTDOWN</b>					
Thermal Shutdown			165		°C
<b>SLOW START (SS PIN)</b>					
Charge current	V <sub>(SS)</sub> = 0.4 V		2		μA

(1) Specified by design

## 6.6 Typical Characteristics

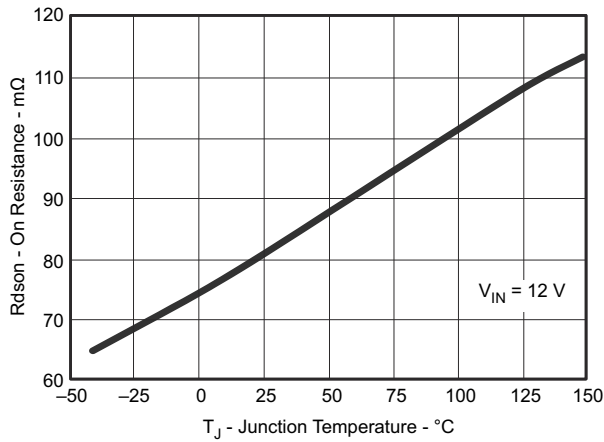


Figure 6-1. ON Resistance vs Junction Temperature

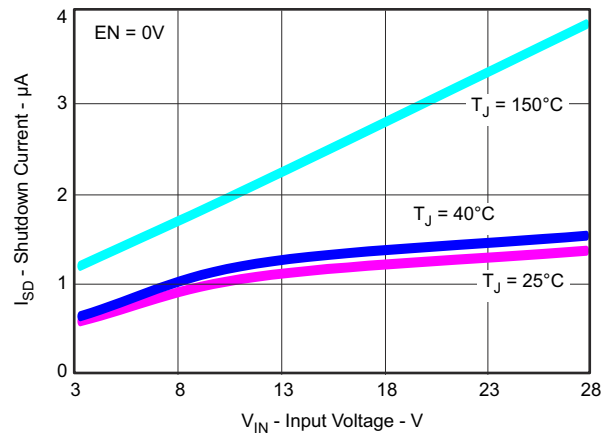


Figure 6-2. Shutdown Quiescent Current vs Input Voltage

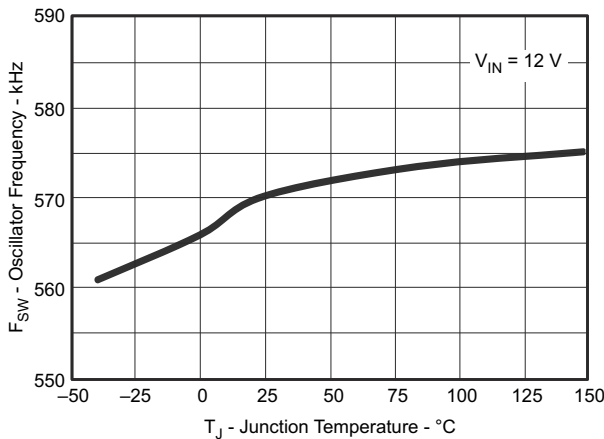


Figure 6-3. Switching Frequency vs Junction Temperature

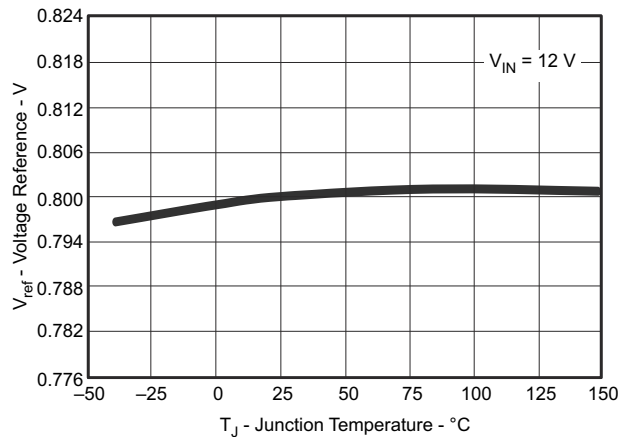


Figure 6-4. Voltage Reference vs Junction Temperature

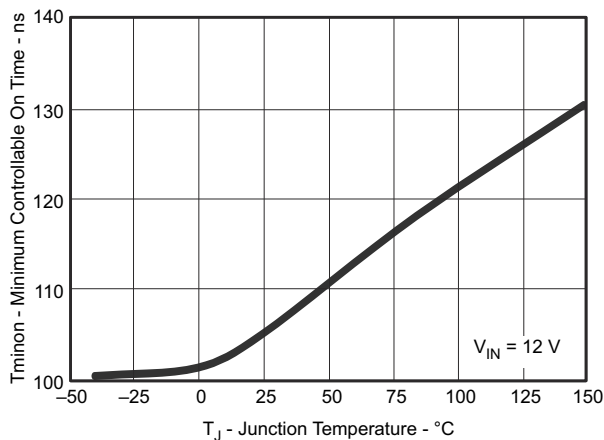


Figure 6-5. Minimum Controllable ON Time vs Junction Temperature

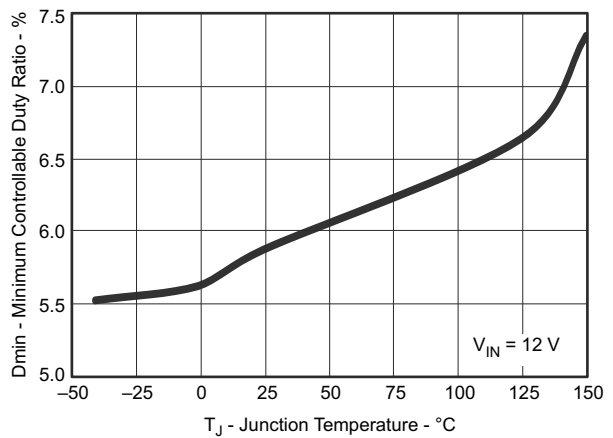
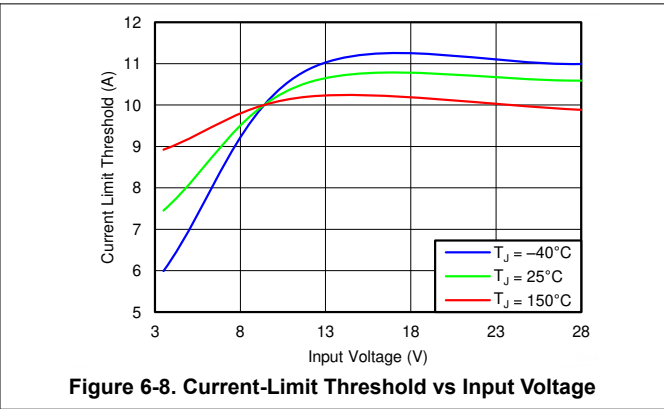
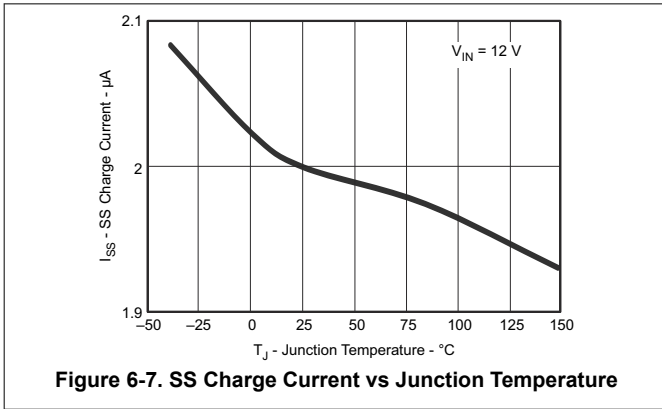


Figure 6-6. Minimum Controllable Duty Ratio vs Junction Temperature

### 6.6 Typical Characteristics (continued)



## 7 Detailed Description

### 7.1 Overview

The TPS54531 device is a 28-V, 5-A, step-down (buck) converter with an integrated high-side n-channel MOSFET. To improve performance during line and load transients, the device implements a constant-frequency, current mode control which reduces output capacitance and simplifies external frequency compensation design. The TPS54531 device has a preset switching frequency of 570 kHz.

The TPS54531 device requires a minimum input voltage of 3.5 V for normal operation. The EN pin has an internal pullup current source that can be used to adjust the input-voltage undervoltage lockout (UVLO) with two external resistors. In addition, the pullup current provides a default condition when the EN pin is floating for the device to operate. The operating current is 110  $\mu$ A (typical) when not switching and under no load. When the device is disabled, the supply current is 1  $\mu$ A (typical).

The integrated 80-m $\Omega$  high-side MOSFET allows for high-efficiency power-supply designs with continuous output currents up to 5 A.

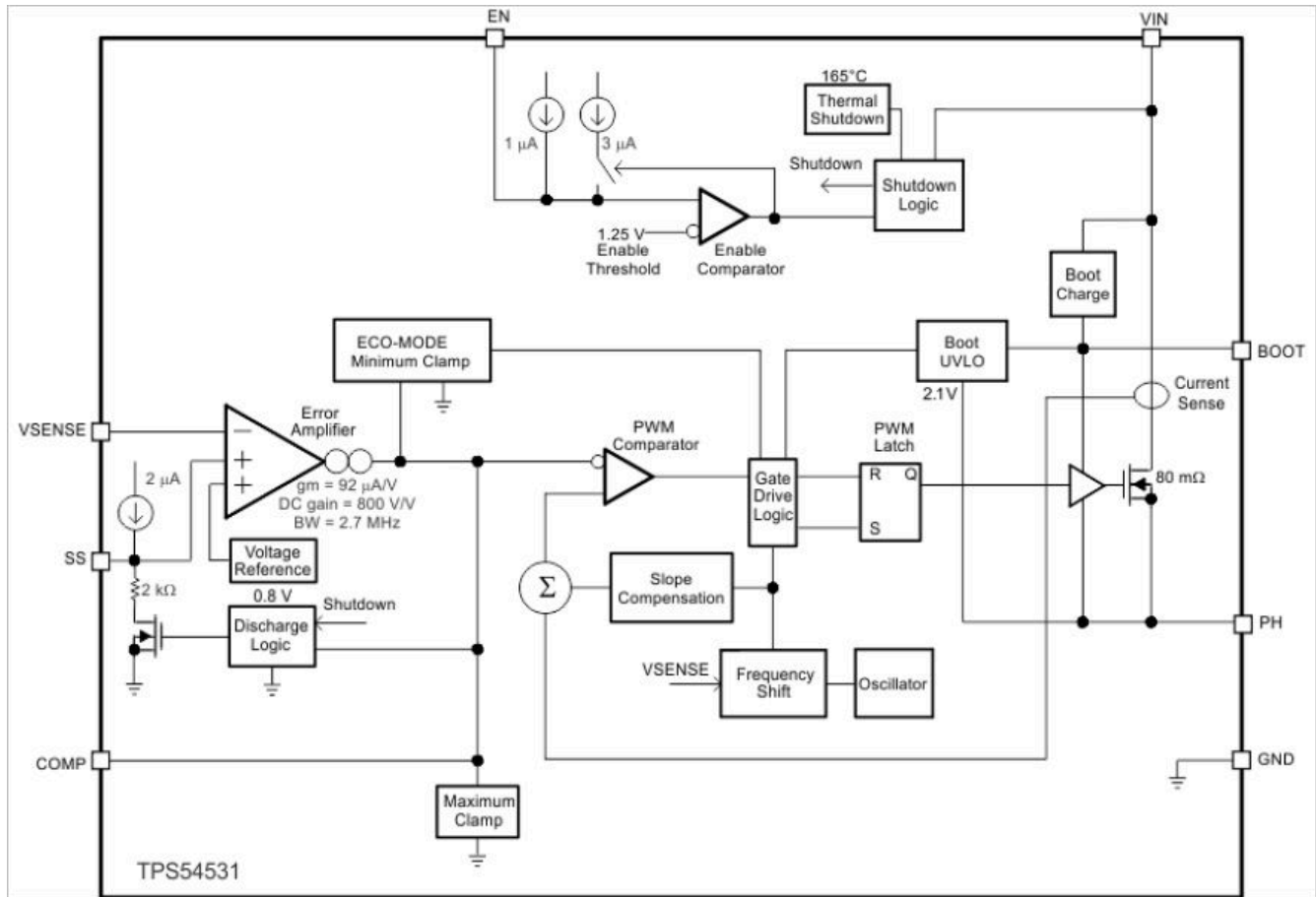
The TPS54531 device reduces the external component count by integrating the boot recharge diode. The bias voltage for the integrated high-side MOSFET is supplied by an external capacitor on the BOOT to PH pin. The boot capacitor voltage is monitored by an UVLO circuit and turns the high-side MOSFET off when the voltage falls below a preset threshold of 2.1 V (typical). The output voltage can be stepped down to as low as the reference voltage.

By adding an external capacitor, the slow-start time of the TPS54531 device can be adjustable which enables flexible output filter selection.

To improve the efficiency at light load conditions, the TPS54531 device enters a special pulse skipping Eco-mode when the peak inductor current drops below 160 mA (typical).

The frequency foldback reduces the switching frequency during start-up and overcurrent conditions to help control the inductor current. The thermal shutdown provides the additional protection under fault conditions.

## 7.2 Functional Block Diagram



## 7.3 Feature Description

### 7.3.1 Fixed-Frequency PWM Control

The TPS54531 device uses a fixed-frequency, peak-current mode control. The internal switching frequency of the TPS54531 device is fixed at 570 kHz.

### 7.3.2 Voltage Reference ( $V_{ref}$ )

The voltage reference system produces a  $\pm 2\%$  initial accuracy voltage reference ( $\pm 3.5\%$  over temperature) by scaling the output of a temperature stable bandgap circuit. The typical voltage reference is designed at 0.8 V.

### 7.3.3 Bootstrap Voltage (BOOT)

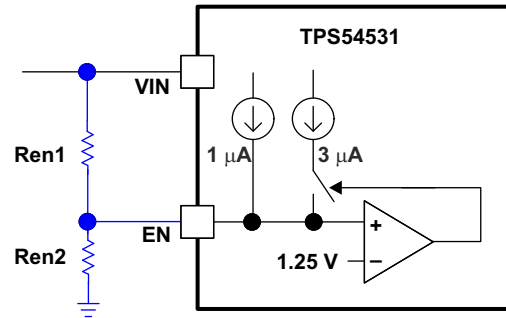
The TPS54531 device has an integrated boot regulator and requires a 0.1- $\mu\text{F}$  ceramic capacitor between the BOOT and PH pins to provide the gate-drive voltage for the high-side MOSFET. A ceramic capacitor with an X7R- or X5R-grade dielectric is recommended because of the stable characteristics over temperature and voltage. To improve drop out, the TPS54531 device is designed to operate at 100% duty cycle as long as the BOOT-to-PH pin voltage is greater than 2.1 V (typical).

### 7.3.4 Enable and Adjustable Input Undervoltage Lockout ( $V_{IN}$ UVLO)

The EN pin has an internal pullup current-source that provides the default condition of the TPS54531 device while operating when the EN pin floats.

The TPS54531 device is disabled when the VIN pin voltage falls below the internal VIN UVLO threshold. Using an external VIN UVLO to add at least 500-mV hysteresis is recommended unless the VIN voltage is greater than ( $V_{OUT} + 2$  V). To adjust the VIN UVLO with hysteresis, use the external circuitry connected to the EN pin as

shown in [Figure 7-1](#). When the EN pin voltage exceeds 1.25 V, an additional 3  $\mu\text{A}$  of hysteresis is added. Use [Equation 1](#) and [Equation 2](#) to calculate the resistor values required for the desired VIN UVLO threshold voltages. The  $V_{\text{STOP}}$  must always be greater than 3.5 V.



**Figure 7-1. Adjustable Input Undervoltage Lockout**

$$\text{Ren1} = \frac{V_{\text{START}} - V_{\text{STOP}}}{3\mu\text{A}} \quad (1)$$

where

- $V_{\text{START}}$  is the input start threshold voltage
- $V_{\text{STOP}}$  is the input stop threshold voltage

$$\text{Ren2} = \frac{V_{\text{EN}}}{\frac{V_{\text{START}} - V_{\text{EN}}}{\text{Ren1}} + 1\mu\text{A}} \quad (2)$$

where

- $V_{\text{EN}}$  is the enable threshold voltage of 1.25 V

The external start and stop voltages are approximate. The actual start and stop voltages can vary.

### 7.3.5 Programmable Slow Start Using SS Pin

Programming the slow-start time externally is highly recommended because no slow-start time is implemented internally. The TPS54531 device effectively uses the lower voltage of the internal voltage reference or the SS pin voltage as the reference voltage of the power supply that is fed into the error amplifier and regulates the output accordingly. A capacitor ( $C_{\text{SS}}$ ) on the SS pin to ground implements a slow-start time. The TPS54531 device has an internal pullup current source of 2  $\mu\text{A}$  that charges the external slow-start capacitor. Use [Equation 3](#) to calculate the slow-start time (10% to 90%).

$$T_{\text{SS}}(\text{ms}) = \frac{C_{\text{SS}}(\text{nF}) \times V_{\text{REF}}(\text{V})}{I_{\text{SS}}(\mu\text{A})} \quad (3)$$

where

- $V_{\text{REF}} = 0.8 \text{ V}$
- $I_{\text{SS}} = 2 \mu\text{A}$

The slow-start time must be set between 1 ms to 10 ms to ensure good startup behavior. The value slow-start capacitor must not exceed 27 nF.

During normal operation, the TPS54531 device stops switching if the input voltage drops below the VIN UVLO threshold, the EN pin is pulled below 1.25 V, or a thermal shutdown event occurs.

### 7.3.6 Error Amplifier

The TPS54531 device has a transconductance amplifier for the error amplifier. The error amplifier compares the VSENSE voltage to the internal effective voltage reference presented at the input of the error amplifier. The transconductance of the error amplifier is 92  $\mu\text{A/V}$  during normal operation. Frequency compensation components are connected between the COMP pin and ground.

### 7.3.7 Slope Compensation

To prevent the sub-harmonic oscillations when operating the device at duty cycles greater than 50%, the TPS54531 device adds a built-in slope compensation which is a compensating ramp to the switch-current signal.

### 7.3.8 Current-Mode Compensation Design

The device is able to work with various types of output capacitors with appropriate compensation designs. For designs using ceramic output capacitors, proper derating of ceramic output capacitance is recommended when performing the stability analysis because the actual ceramic capacitance drops considerably from the nominal value when the applied voltage increases. For the detailed guidelines, see the [Section 8.2.2](#) section.

### 7.3.9 Overcurrent Protection and Frequency Shift

The TPS54531 device implements current mode control that uses the COMP pin voltage to turn off the high-side MOSFET on a cycle-by-cycle basis. During each cycle the switch current and the COMP pin voltage are compared. When the peak inductor current intersects the COMP pin voltage, the high-side switch is turned off. During overcurrent conditions that pull the output voltage low, the error amplifier responds by driving the COMP pin high, causing the switch current to increase. The COMP pin has a maximum clamp internally, which limits the output current.

The TPS54531 device provides robust protection during short circuits. Overcurrent runaway is possible in the output inductor during a short circuit at the output. The TPS54531 device solves this issue by increasing the off time during short-circuit conditions by lowering the switching frequency. The switching frequency is divided by 1, 2, 4, and 8 as the voltage ramps from 0 V to 0.8 V on VSENSE pin. The relationship between the switching frequency and the VSENSE pin voltage is listed in [Table 7-1](#).

**Table 7-1. Switching Frequency Conditions**

SWITCHING FREQUENCY	VSENSE PIN VOLTAGE
570 kHz	$V_{SENSE} \geq 0.6 \text{ V}$
570 kHz / 2	$0.6 \text{ V} > V_{SENSE} \geq 0.4 \text{ V}$
570 kHz / 4	$0.4 \text{ V} > V_{SENSE} \geq 0.2 \text{ V}$
570 kHz / 8	$0.2 \text{ V} > V_{SENSE}$

### 7.3.10 Overvoltage Transient Protection

The TPS54531 device incorporates an overvoltage transient-protection (OVTP) circuit to minimize output voltage overshoot when recovering from output fault conditions or strong unload transients. The OVTP circuit includes an overvoltage comparator to compare the VSENSE pin voltage and internal thresholds. When the VSENSE pin voltage goes above  $109\% \times V_{ref}$ , the high-side MOSFET is forced off. When the VSENSE pin voltage falls below  $107\% \times V_{ref}$ , the high-side MOSFET is enabled again.

### 7.3.11 Thermal Shutdown

The device implements an internal thermal shutdown to protect the device if the junction temperature exceeds 165°C. The thermal shutdown forces the device to stop switching when the junction temperature exceeds the thermal trip threshold. When the die temperature decreases below 165°C, the device reinitiates the power-up sequence.

## 7.4 Device Functional Modes

### 7.4.1 Eco-mode

The TPS54531 is designed to operate in pulse skipping Eco-mode at light load currents to boost light load efficiency. When the peak inductor current is lower than 160 mA (typical), the COMP pin voltage falls to 0.5 V (typical) and the device enters Eco-mode. When the device is in Eco-mode, the COMP pin voltage is clamped at 0.5-V internally which prevents the high-side integrated MOSFET from switching. The peak inductor current must rise above 160 mA for the COMP pin voltage to rise above 0.5 V and exit Eco-mode. Because the integrated current comparator catches the peak inductor current only, the average load current entering Eco-mode varies with the applications and external output filters.

### 7.4.2 Operation With $V_{IN} < 3.5$ V

The device is recommended to operate with input voltages above 3.5 V. The typical VIN UVLO threshold is not specified and the device can operate at input voltages down to the UVLO voltage. At input voltages below the actual UVLO voltage, the device does not switch. If the EN pin is externally pulled up or left floating, the device becomes active when the VIN pin passes the UVLO threshold. Switching begins when the slow-start sequence is initiated.

### 7.4.3 Operation With EN Control

The enable threshold voltage is 1.25 V (typical). With the EN pin is held below that voltage the device is disabled and switching is inhibited even if the VIN pin is above the UVLO threshold. The IC quiescent current is reduced in this state. If the EN voltage increases above the threshold while the VIN pin is above the UVLO threshold, the device becomes active. Switching is enabled, and the slow-start sequence is initiated.

## 8 Application and Implementation

### Note

Information in the following applications sections is not part of the TI component specification, and TI does not warrant its accuracy or completeness. TI's customers are responsible for determining suitability of components for their purposes, as well as validating and testing their design implementation to confirm system functionality.

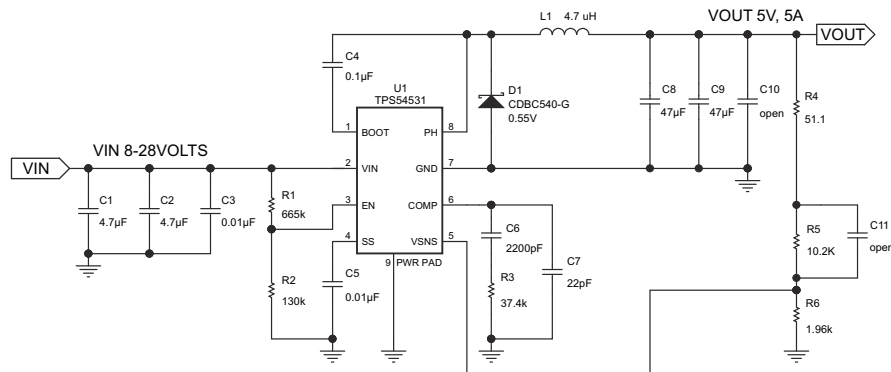
### 8.1 Application Information

The TPS54531 device is typically used as a step-down converter, which converts a voltage from 3.5 V to 28 V to a lower voltage. WEBENCH® software is available to aid in the design and analysis of circuits.

For additional design needs, see the following devices:

	TPS54231	TPS54232	TPS54233	TPS54531	TPS54332
I(max)	2 A	2 A	2 A	5 A	3.5 A
Input voltage range	3.5 to 28 V	3.5 to 28 V	3.5 to 28 V	3.5 to 28 V	3.5 to 28 V
Switching frequency (typical)	570 kHz	1000 kHz	285 kHz	570 kHz	1000 kHz
Switch current limit (minimum)	2.3 A	2.3 A	2.3 A	5.5 A	4.2 A
Pin and package	8SOIC	8SOIC	8SOIC	8SO PowerPAD integrated circuit package	8SO PowerPAD integrated circuit package

### 8.2 Typical Application



**Figure 8-1. Typical Application Schematic**

#### 8.2.1 Design Requirements

For this design example, use the values listed in [Table 8-1](#) as the input parameters

**Table 8-1. Design Parameters**

DESIGN PARAMETER	EXAMPLE VALUE
Input voltage range	8 to 28 V
Output voltage	5 V
Transient response, 2.5-A load step	$\Delta V_{OUT} = \pm 5\%$
Input ripple voltage	400 mV
Output ripple voltage	30 mV
Output current rating	5 A
Operating Frequency	570 kHz

## 8.2.2 Detailed Design Procedure

The following design procedure can be used to select component values for the TPS54531 device. Alternately, the WEBENCH software can be used to generate a complete design. The WEBENCH software uses an iterative design procedure and accesses a comprehensive database of components when generating a design. This section presents a simplified discussion of the design process.

### 8.2.2.1 Custom Design With WEBENCH® Tools

[Click here](#) to create a custom design using the WEBENCH Power Designer.

1. Start by entering your  $V_{IN}$ ,  $V_{OUT}$  and  $I_{OUT}$  requirements.
2. Optimize your design for key parameters like efficiency, footprint and cost using the optimizer dial and compare this design with other possible solutions from Texas Instruments.
3. WEBENCH Power Designer provides you with a customized schematic along with a list of materials with real time pricing and component availability.
4. In most cases, users are able to:
  - Run electrical simulations to see important waveforms and circuit performance,
  - Run thermal simulations to understand the thermal performance of your board,
  - Export your customized schematic and layout into popular CAD formats,
  - Print PDF reports for the design, and share your design with colleagues.

Get more information about WEBENCH tools at [www.ti.com/WEBENCH](http://www.ti.com/WEBENCH).

### 8.2.2.2 Switching Frequency

The switching frequency for the TPS54531 is fixed at 570 kHz.

### 8.2.2.3 Output Voltage Set Point

The output voltage of the TPS54531 device is externally adjustable using a resistor divider network. As shown in [Figure 8-1](#), this divider network is comprised of R5 and R6. The relationship of the output voltage to the resistor divider is given by [Equation 4](#) and [Equation 5](#):

$$R6 = \frac{R5 \times V_{REF}}{V_{OUT} - V_{REF}} \quad (4)$$

$$V_{OUT} = V_{REF} \times \left( \frac{R5}{R6} + 1 \right) \quad (5)$$

Select a value of R5 to be approximately 10 kΩ. Slightly increasing or decreasing the value of R5 can result in closer output-voltage matching when using standard value resistors. In this design, R5 = 10.2 kΩ and R6 = 1.96 kΩ, resulting in a 4.96 V output voltage. The 51.1-Ω resistor, R4, is provided as a convenient location to break the control loop for stability testing.

### 8.2.2.4 Undervoltage Lockout Set Point

The undervoltage lockout (UVLO) can be adjusted using the external voltage divider network of R1 and R2. R1 is connected between the VIN and EN pins of the TPS54531 device and R2 is connected between the EN and GND pins. The UVLO has two thresholds, one for power up when the input voltage is rising and one for power down or brown outs when the input voltage is falling. For the design example, the minimum input voltage is 8 V. Therefore the start voltage threshold is set to 7 V with 2-V hysteresis. Use [Equation 1](#) and [Equation 2](#) to calculate the values for the upper and lower resistor values of R1 and R2.

### 8.2.2.5 Input Capacitors

The TPS54531 device requires an input decoupling capacitor and, depending on the application, a bulk input capacitor. The typical recommended value for the decoupling capacitor is 10 μF. A high-quality ceramic type X5R or X7R is recommended. The voltage rating must be greater than the maximum input voltage. A smaller value can be used as long as all other requirements are met; however 10 μF has been shown to work well in a wide variety of circuits. Additionally, some bulk capacitance can be required, especially if the TPS54531 circuit is not

located within about 2 inches from the input voltage source. The value for this capacitor is not critical but must be rated to handle the maximum input voltage including ripple voltage, and must filter the output so that input ripple voltage is acceptable. For this design two 4.7- $\mu\text{F}$  capacitors are used for the input decoupling capacitor. The capacitors are X7R dielectric rated for 50 V. The equivalent series resistance (ESR) is approximately 2 m $\Omega$  and the current rating is 3 A. Additionally, a small 0.01  $\mu\text{F}$  capacitor is included for high frequency filtering.

Use [Equation 6](#) to calculate the input ripple voltage.

$$\Delta V_{\text{IN}} = \frac{I_{\text{OUT(MAX)}} \times 0.25}{C_{\text{BULK}} \times F_{\text{SW}}} + (I_{\text{OUT(MAX)}} \times \text{ESR}_{\text{MAX}}) \quad (6)$$

where

- $I_{\text{OUT(MAX)}}$  is the maximum load current
- $C_{\text{BULK}}$  is the bulk capacitor value
- $F_{\text{SW}}$  is the switching frequency
- $\text{ESR}_{\text{MAX}}$  is the maximum series resistance of the bulk capacitor

The maximum RMS ripple current must also be checked. For worst case conditions, use [Equation 7](#) to calculate the maximum-RMS input ripple current,  $I_{\text{CIN(RMS)}}$ .

$$I_{\text{CIN(RMS)}} = \frac{I_{\text{OUT(MAX)}}}{2} \quad (7)$$

In this case, the input ripple voltage is 243 mV and the RMS ripple current is 2.5 A.

---

#### Note

The actual input voltage ripple is greatly affected by parasitics associated with the layout and the output impedance of the voltage source.

---

The actual input voltage ripple for this circuit is listed in [Table 8-1](#) and is larger than the calculated value. This measured value is still below the specified input limit of 300 mV. The maximum voltage across the input capacitors is  $V_{\text{IN(MAX)}} + \Delta V_{\text{IN}} / 2$ . The selected bulk and bypass capacitors are each rated for 50 V and the ripple current capacity is greater than 3 A, both providing ample margin. The maximum ratings for voltage and current must not be exceeded under any circumstance.

### 8.2.2.6 Output Filter Components

Two components must be selected for the output filter,  $L_{\text{OUT}}$  and  $C_{\text{OUT}}$ . Because the TPS54531 is an externally compensated device, a wide range of filter component types and values can be supported.

#### 8.2.2.6.1 Inductor Selection

To calculate the minimum value of the output inductor, use [Equation 8](#)

$$L_{\text{MIN}} = \frac{V_{\text{OUT}} \times (V_{\text{IN(MAX)}} - V_{\text{OUT}})}{V_{\text{IN(MAX)}} \times K_{\text{IND}} \times I_{\text{OUT}} \times F_{\text{SW}}} \quad (8)$$

where

- $K_{\text{IND}}$  is a coefficient that represents the amount of inductor ripple current relative to the maximum output current

In general, this value is at the discretion of the designer; however, the following guidelines can be used. For designs using low-ESR output capacitors such as ceramics, a value as high as  $K_{\text{IND}} = 0.3$  can be used. When using higher ESR output capacitors,  $K_{\text{IND}} = 0.2$  yields better results.

For this design example, use  $K_{\text{IND}} = 0.3$  and the minimum inductor value is calculated as 4.8  $\mu\text{H}$ . For this design, a close, standard value was chosen: 4.7  $\mu\text{H}$ .

For the output filter inductor, do not exceed the RMS current and saturation current ratings. Use [Equation 9](#) to calculate the inductor ripple current ( $I_{\text{RIPPLE}}$ ).

$$I_{\text{RIPPLE}} = \frac{V_{\text{OUT}} \times (V_{\text{IN(MAX)}} - V_{\text{OUT}})}{V_{\text{IN(MAX)}} \times L_{\text{OUT}} \times F_{\text{SW}} \times 0.8} \quad (9)$$

Use [Equation 10](#) to calculate the RMS inductor current.

$$I_{\text{L(RMS)}} = \sqrt{I_{\text{OUT(MAX)}}^2 + \frac{1}{12} \times \left( \frac{V_{\text{OUT}} \times (V_{\text{IN(MAX)}} - V_{\text{OUT}})}{V_{\text{IN(MAX)}} \times L_{\text{OUT}} \times F_{\text{SW}} \times 0.8} \right)^2} \quad (10)$$

Use [Equation 11](#) to calculate the peak inductor current.

$$I_{\text{L(PK)}} = I_{\text{OUT(MAX)}} + \frac{V_{\text{OUT}} \times (V_{\text{IN(MAX)}} - V_{\text{OUT}})}{1.6 \times V_{\text{IN(MAX)}} \times L_{\text{OUT}} \times F_{\text{SW}}} \quad (11)$$

For this design, the RMS inductor current is 5.03 A and the peak inductor current is 5.96 A. The selected inductor is a Würth 4.7  $\mu\text{H}$ . This inductor has a saturation current rating of 19 A and an RMS current rating of 7 A, which meets these requirements. Smaller or larger inductor values can be used depending on the amount of ripple current the designer wants to allow, so long as the other design requirements are met. Larger value inductors have lower AC current and result in lower output voltage ripple, while smaller inductor values increase AC current and output voltage ripple. In general, inductor values for use with the TPS54531 device are in the range of 1  $\mu\text{H}$  to 47  $\mu\text{H}$ .

#### 8.2.2.6.2 Capacitor Selection

Selecting the value of the output capacitor is based on three primary considerations. The output capacitor determines the modulator pole, the output voltage ripple, and how the regulator responds to a large change in load current. The output capacitance must be selected based on the more stringent of these three criteria.

The desired response to a large change in the load current is the first criteria. The output capacitor must supply the load with current when the regulator can not. This situation occurs if desired hold-up times occur for the regulator where the output capacitor must hold the output voltage above a certain level for a specified amount of time after the input power is removed. The regulator is also temporarily not able to supply sufficient output current if a large, fast increase occurs in the current needs of the load, such as a transition from no load to full load. The regulator usually requires two or more clock cycles for the control loop to respond to the change in load current and output voltage and adjust the duty cycle to react to the change. The output capacitor must be sized to supply the extra current to the load until the control loop responds to the load change. The output capacitance must be large enough to supply the difference in current for 2 clock cycles while only allowing a tolerable amount of drop in the output voltage. Use [Equation 12](#) to calculate minimum output capacitance ( $C_{\text{O}}$ ) required in this case.

$$C_{\text{O}} > \frac{2 \times \Delta I_{\text{OUT}}}{F_{\text{SW}} \times \Delta V_{\text{OUT}}} \quad (12)$$

where

- $\Delta I_{\text{OUT}}$  is the change in output current
- $F_{\text{SW}}$  is the switching frequency of the regulator
- $\Delta V_{\text{OUT}}$  is the allowable change in the output voltage

For this example, the transient load response is specified as a 5% change in  $V_{\text{OUT}}$  for a load step of 2.5 A. For this example,  $\Delta I_{\text{OUT}} = 2.5$  A and  $\Delta V_{\text{OUT}} = 0.05 \times 5 = 0.25$  V. Using these values results in a minimum capacitance of 35  $\mu\text{F}$ . This value does not consider the ESR of the output capacitor in the output voltage change. For ceramic capacitors, the ESR is usually small enough to ignore in this calculation.

Use [Equation 13](#) to calculate the minimum output capacitance needed to meet the output voltage ripple specification. In this case, the maximum output voltage ripple is 30 mV. Under this requirement [Equation 13](#), yields 14  $\mu\text{F}$ .

$$C_0 > \frac{1}{8 \times F_{\text{SW}}} \times \frac{1}{\frac{V_{\text{OUTRIPPLE}}}{I_{\text{RIPPLE}}}} \quad (13)$$

where

- $F_{\text{SW}}$  is the switching frequency
- $V_{\text{OUTRIPPLE}}$  is the maximum allowable output voltage ripple
- $I_{\text{RIPPLE}}$  is the inductor ripple current

Use [Equation 14](#) to calculate the maximum ESR an output capacitor can have to meet the output-voltage ripple specification. [Equation 14](#) indicates the ESR must be less than 15.6 m $\Omega$ . In this case, the ESR of the ceramic capacitor is much smaller than 15.6 m $\Omega$ .

$$R_{\text{ESR}} < \frac{V_{\text{OUTRIPPLE}}}{I_{\text{RIPPLE}}} \quad (14)$$

Additional capacitance deratings for aging, temperature, and DC bias must be considered which increases this minimum value. For this example, two 47- $\mu\text{F}$  10-V X5R ceramic capacitors with 3 m $\Omega$  of ESR are used. Capacitors generally have limits to the amount of ripple current they can handle without failing or producing excess heat. An output capacitor that can support the inductor ripple current must be specified. Some capacitor data sheets specify the RMS (root mean square) value of the maximum ripple current. Use [Equation 15](#) to calculate the RMS ripple current that the output capacitor must support. For this application, [Equation 15](#) yields 554 mA.

$$I_{\text{COUT(RMS)}} = \frac{1}{\sqrt{12}} \times \left( \frac{V_{\text{OUT}} \times (V_{\text{IN(MAX)}} - V_{\text{OUT}})}{V_{\text{IN(MAX)}} \times L_{\text{OUT}} \times F_{\text{SW}} \times N_{\text{C}}} \right) \quad (15)$$

### 8.2.2.7 Compensation Components

Several possible methods exist to design closed loop compensation for DC/DC converters. For the ideal current mode control, the design equations can be easily simplified. The power stage gain is constant at low frequencies, and rolls off at  $-20$  dB/decade above the modulator pole frequency. The power stage phase is 0 degrees at low frequencies and begins to fall one decade below the modulator pole frequency reaching a minimum of  $-90$  degrees one decade above the modulator pole frequency. Use [Equation 16](#) to calculate the modulator pole frequency.

$$F_{\text{P\_MOD}} = \frac{I_{\text{OUT(MAX)}}}{2 \times \pi \times V_{\text{OUT}} \times C_{\text{OUT}}} \quad (16)$$

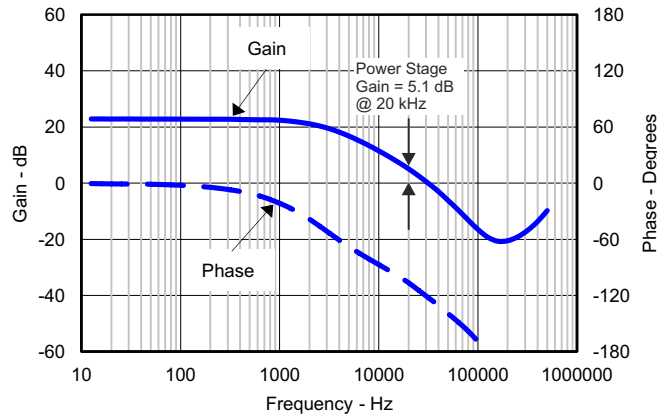
For the TPS54531 device, most circuits have relatively high amounts of slope compensation. As more slope compensation is applied, the power stage characteristics deviate from the ideal approximations. The phase loss of the power stage now approaches  $-180$  degrees, making compensation more difficult. The power stage transfer function can be solved but requires a tedious calculation. Use the PSpice model to accurately model the power-stage gain and phase so that a reliable compensation circuit can be designed. Alternately, a direct measurement of the power stage characteristics can be used. That is the technique used in this design procedure. For this design, the calculate values are as follows:

$L_1 = 4.7 \mu\text{H}$

$C_8$  and  $C_9 = 47 \mu\text{F}$  (each)

ESR = 3 m $\Omega$

[Figure 8-2](#) shows the power stage characteristics.



**Figure 8-2. Power Stage Gain and Phase Characteristics**

For this design, the intended crossover frequency is 20 kHz. From the power stage gain and phase plots, the gain at 20 kHz is 5.1 dB and the phase is about  $-100$  degrees. For 60 degrees of phase margin, additional phase boost from a feed-forward capacitor in parallel with the upper resistor of the voltage set point divider is not needed. R3 sets the gain of the compensated error amplifier to be equal and opposite the power stage gain at crossover. Use Equation 17 to calculate the required value of R3.

$$R_3 = \frac{10^{\frac{-G_{PWRSTG}}{20}}}{g_{mEA}} \times \frac{V_{OUT}}{V_{REF}} \quad (17)$$

To maximize phase gain, the compensator zero is placed one decade below the crossover frequency of 20 kHz. Use Equation 18 to calculate the required value for C6.

$$C_6 = \frac{1}{2 \times \pi \times R_3 \times \frac{F_{CO}}{10}} \quad (18)$$

To maximize phase gain the high frequency pole is placed one decade above the crossover frequency of 20 kHz. The pole can also be useful to offset the ESR of aluminum electrolytic output capacitors. Use Equation 19 to calculate the value for C7.

$$C_7 = \frac{1}{2 \times \pi \times R_3 \times 10 \times F_{CO}} \quad (19)$$

For this design, the calculated values are as follows:

$$R_3 = 37.4 \text{ k}\Omega$$

$$C_6 = 2200 \text{ pF}$$

$$C_7 = 22 \text{ pF}$$

### 8.2.2.8 Bootstrap Capacitor

Every TPS54531 design requires a bootstrap capacitor, C4. The bootstrap capacitor value must be 0.1  $\mu\text{F}$ . The bootstrap capacitor is located between the PH and BOOT pins. The bootstrap capacitor must be a high-quality ceramic type with X7R or X5R grade dielectric for temperature stability.

### 8.2.2.9 Catch Diode

The TPS54531 device is designed to operate using an external catch diode between the PH and GND pins. The selected diode must meet the absolute maximum ratings for the application. The reverse voltage must be higher than the maximum voltage at the PH pin, which is  $V_{IN(MAX)} + 0.5 \text{ V}$ . Peak current must be greater than  $I_{O(MAX)}$  plus on half the peak-to-peak inductor current. The forward-voltage drop must be small for higher efficiencies. The catch diode conduction time is (typically) longer than the high-side FET on time, so attention

paid to diode parameters can make a marked improvement in overall efficiency. Additionally, check that the selected device is capable of dissipating the power losses. For this design, a CDBC540-G was selected, with a reverse voltage of 40 V, forward current of 5 A, and a forward-voltage drop of 0.55 V.

### 8.2.2.10 Slow-Start Capacitor

The slow-start capacitor determines the minimum amount of time required for the output voltage to reach the nominal programmed value during power up which is useful if a load requires a controlled voltage slew rate. The slow-start capacitor is also used if the output capacitance is very large and requires large amounts of current to quickly charge the capacitor to the output voltage level. The large currents necessary to charge the capacitor can make the TPS54531 device reach the current limit. Excessive current draw from the input power supply can cause the input voltage rail to sag. Limiting the output voltage slew rate solves both of these problems. Use [Equation 3](#) to calculate the value of the slow-start capacitor. For the example circuit, the slow-start time is not too critical because the output capacitor value is  $2 \times 47 \mu\text{F}$  which does not require much current to charge to 5 V. The example circuit has the slow-start time set to an arbitrary value of 4 ms which requires a 10-nF capacitor. For the TPS54531 device,  $I_{\text{SS}}$  is 2  $\mu\text{A}$  and  $V_{\text{ref}}$  is 0.8 V.

### 8.2.2.11 Output Voltage Limitations

Because of the internal design of the TPS54531 device, any give voltage has both upper and lower output voltage limits for any given input voltage. The upper limit of the output-voltage set point is constrained by the maximum duty cycle of 91% and is calculated with [Equation 20](#). The equation assumes the maximum ON resistance for the internal high-side FET.

$$V_{\text{O(MAX)}} = 0.91 \times \left( (V_{\text{IN(MIN)}} - I_{\text{O(MAX)}} \times R_{\text{DS(ON)MAX}}) + V_{\text{D}} \right) - (I_{\text{O(MAX)}} \times R_{\text{L}}) - V_{\text{D}} \quad (20)$$

where

- $V_{\text{IN(MIN)}}$  = Minimum input voltage
- $I_{\text{O(MAX)}}$  = Maximum load current
- $V_{\text{D}}$  = Catch diode forward voltage
- $R_{\text{L}}$  = Output inductor series resistance

The lower limit is constrained by the minimum controllable on time which can be as high as 130 ns. The approximate minimum output voltage for a given input voltage and minimum load current is given by [Equation 21](#).

$$V_{\text{O(MIN)}} = 0.089 \times \left( (V_{\text{IN(MAX)}} - I_{\text{O(MIN)}} \times R_{\text{DS(ON)MIN}}) + V_{\text{D}} \right) - (I_{\text{O(MIN)}} \times R_{\text{L}}) - V_{\text{D}} \quad (21)$$

where

- $V_{\text{IN(MAX)}}$  = Maximum input voltage
- $I_{\text{O(MIN)}}$  = Minimum load current
- $V_{\text{D}}$  = Catch diode forward voltage
- $R_{\text{L}}$  = Output inductor series resistance

This equation assumes nominal on-resistance for the high-side FET and accounts for worst case variation of operating frequency set point. Any design operating near the operational limits of the device must be carefully checked to ensure proper functionality.

### 8.2.2.12 Power Dissipation Estimate

The following formulas show how to estimate the device power dissipation under continuous-conduction mode (CCM) operations. These formulas must not be used if the device is working in the discontinuous-conduction mode (DCM) or pulse-skipping Eco-mode.

The device power dissipation includes:

1. Conduction loss:

$$P_{con} = I_{OUT}^2 \times R_{DS(on)} \times V_{OUT} / V_{IN}$$

- where
- $I_{OUT}$  is the output current (A)
- $R_{DS(on)}$  is the on-resistance of the high-side MOSFET ( $\Omega$ )
- $V_{OUT}$  is the output voltage (V)
- $V_{IN}$  is the input voltage (V)

2. Switching loss:

$$P_{sw} = 0.5 \times 10^{-9} \times V_{IN}^2 \times I_{OUT} \times f_{SW}$$

- where
- $f_{SW}$  is the switching frequency (Hz)

3. Gate charge loss:

$$P_{gc} = 22.8 \times 10^{-9} \times f_{SW}$$

4. Quiescent current loss:

$$P_q = 0.11 \times 10^{-3} \times V_{IN}$$

Therefore:

$$P_{tot} = P_{con} + P_{sw} + P_{gc} + P_q$$

where

- $P_{tot}$  is the total device power dissipation (W)

For given  $T_A$ :

$$T_J = T_A + R_{th} \times P_{tot}$$

where

- $T_J$  is the junction temperature ( $^{\circ}\text{C}$ )
- $T_A$  is the ambient temperature ( $^{\circ}\text{C}$ )
- $R_{th}$  is the thermal resistance of the package ( $^{\circ}\text{C}/\text{W}$ )

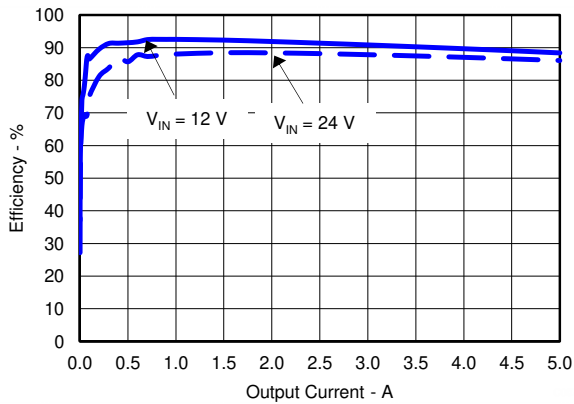
For given  $T_{JMAX} = 150^{\circ}\text{C}$ :

$$T_{AMAX} = T_{JMAX} - R_{th} \times P_{tot}$$

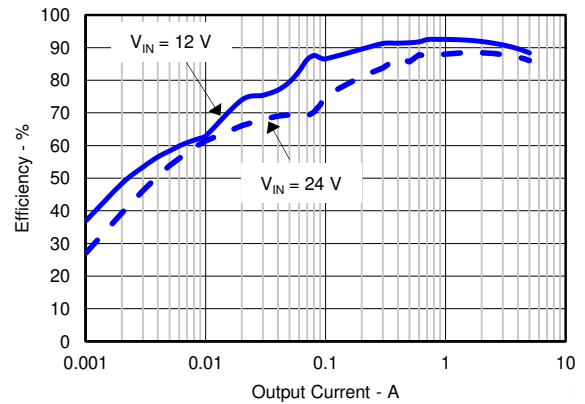
where

- $T_{JMAX}$  is maximum junction temperature ( $^{\circ}\text{C}$ )
- $T_{AMAX}$  is maximum ambient temperature ( $^{\circ}\text{C}$ )

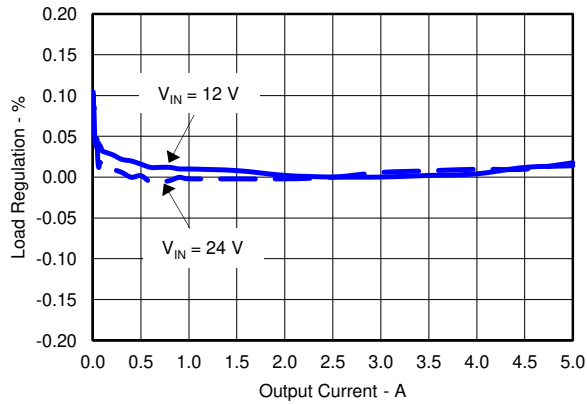
### 8.2.3 Application Curves



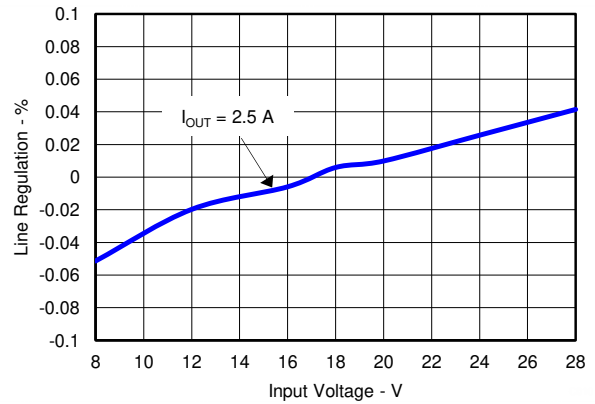
**Figure 8-3. Efficiency**



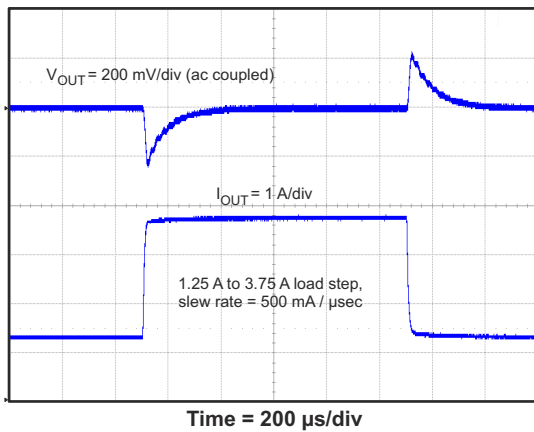
**Figure 8-4. Low-Current Efficiency**



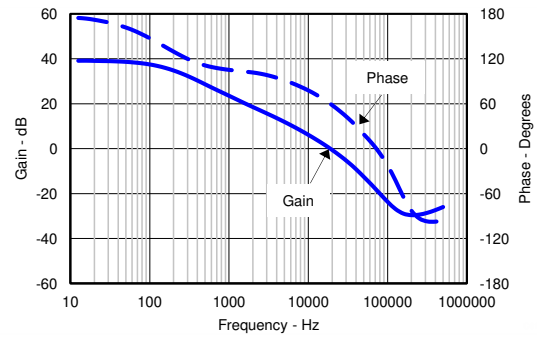
**Figure 8-5. Load Regulation**



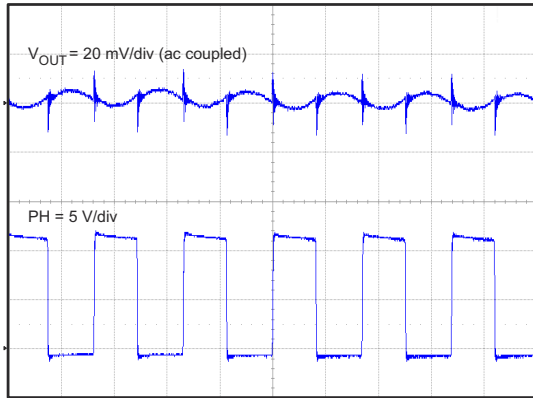
**Figure 8-6. Line Regulation**



**Figure 8-7. Transient Response**

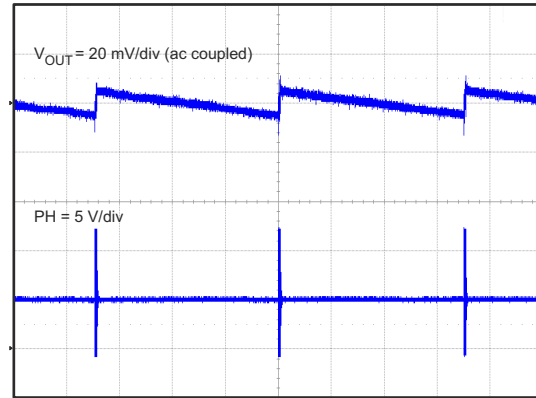


**Figure 8-8. Loop Response**



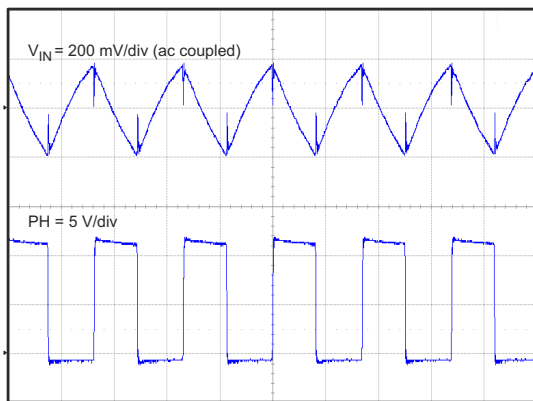
Time = 1  $\mu$ s/div

**Figure 8-9. Full-Load Output Ripple**



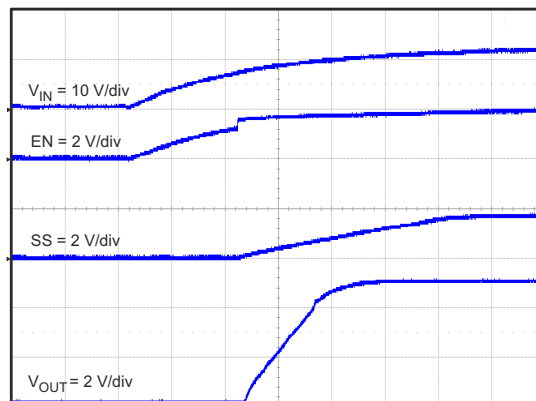
Time = 500  $\mu$ s/div

**Figure 8-10. Eco-mode Output Ripple**



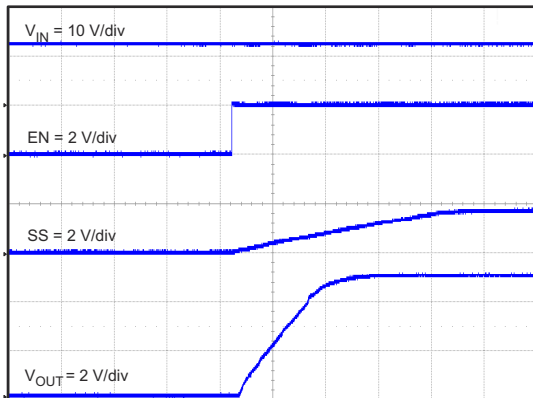
Time = 1  $\mu$ s/div

**Figure 8-11. Full-Load Input Ripple**



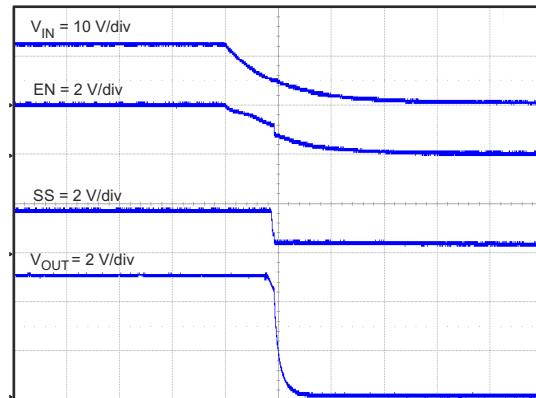
Time = 2 ms/div

**Figure 8-12. Startup Relative to VIN**



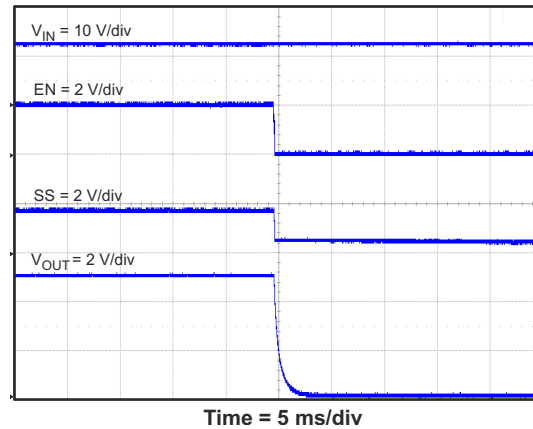
Time = 2 ms/div

**Figure 8-13. Startup Relative to Enable**



Time = 5 ms/div

**Figure 8-14. Shut Down Relative to VIN**



**Figure 8-15. Shut Down Relative to EN**

### 8.3 Power Supply Recommendations

The device is designed to operate from an input-voltage supply range between 3.5 V and 28 V. This input supply must be well regulated. If the input supply is located more than a few inches from the converter additional bulk capacitance can be required in addition to the ceramic bypass capacitors. An electrolytic capacitor with a value of 100  $\mu\text{F}$  is a typical choice.

### 8.4 Layout

#### 8.4.1 Layout Guidelines

The VIN pin must be bypassed to ground with a low-ESR ceramic bypass capacitor. Care must be taken to minimize the loop area formed by the bypass capacitor connections, the VIN pin, and the anode of the catch diode. The typical recommended bypass capacitance is 10- $\mu\text{F}$  ceramic with a X5R or X7R dielectric and the optimum placement is closest to the VIN pins and the source of the anode of the catch diode. [Figure 8-16](#) shows a PCB layout example. The GND pin must be tied to the PCB ground plane at the pin of the device. The PH pin must be routed to the cathode of the catch diode and to the output inductor. Because the PH connection is the switching node, the catch diode and output inductor must be located very close to the PH pins, and the area of the PCB conductor minimized to prevent excessive capacitive coupling. For operation at full rated load, the exposed thermal pad must be soldered directly to the top-side ground area under the device. Use thermal vias to connect the top-side ground area to an internal or bottom-layer ground plane. The total copper area must provide adequate heat dissipation. Additional vias adjacent to the device can be used to improve heat transfer to the internal or bottom-layer ground plane. The additional external components can be placed approximately as shown. Obtaining acceptable performance with alternate layout schemes can be possible, however this layout has been shown to produce good results and is intended as a guideline.

### 8.4.2 Layout Example

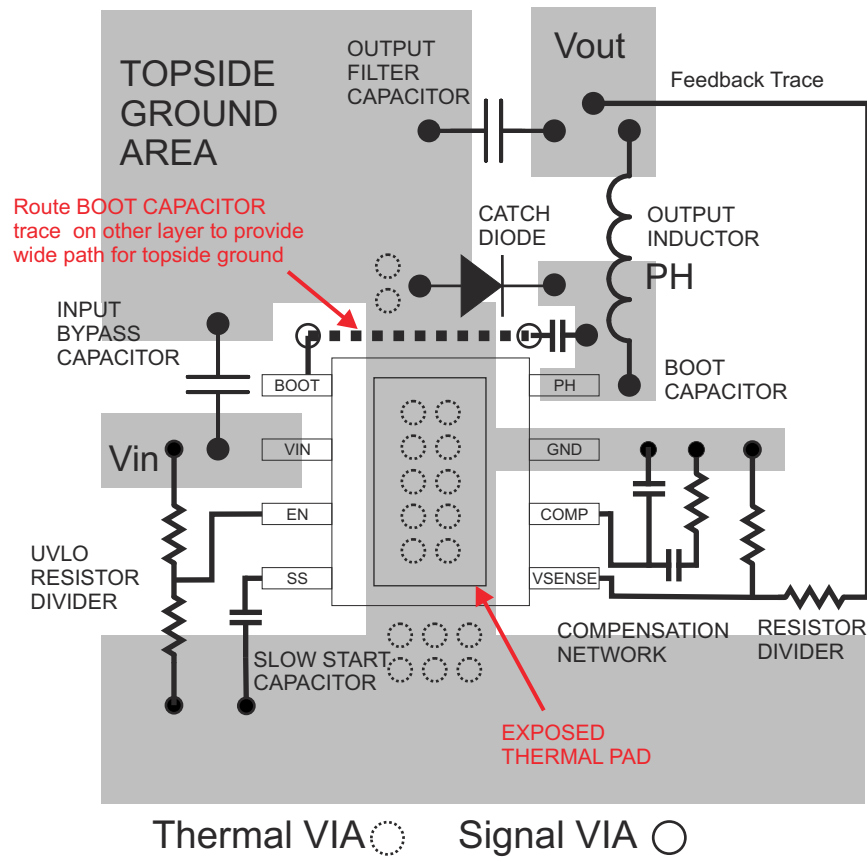


Figure 8-16. TPS54531DDA Board Layout

### 8.4.3 Electromagnetic Interference (EMI) Considerations

As EMI becomes a rising concern in more and more applications, the internal design of the TPS54531 device includes features to reduce the EMI. The high-side MOSFET gate drive is designed to reduce the PH pin voltage ringing. The internal IC rails are isolated to decrease the noise sensitivity. A package bond wire scheme is used to lower the parasitics effects.

To achieve the best EMI performance, external component selection and board layout are equally important. Follow the steps listed in the [Section 8.2.2](#) section to prevent potential EMI issues.

## 9 Device and Documentation Support

### 9.1 Device Support

#### 9.1.1 Development Support

##### 9.1.1.1 Custom Design With WEBENCH® Tools

Create a custom design with the TPS54531 using the [WEBENCH® Power Designer](#)

1. Start by entering the input voltage ( $V_{IN}$ ), output voltage ( $V_{OUT}$ ), and output current ( $I_{OUT}$ ) requirements.
2. Optimize the design for key parameters such as efficiency, footprint, and cost using the optimizer dial.
3. Compare the generated design with other possible solutions from Texas Instruments.

The WEBENCH Power Designer gives a customized schematic along with a list of materials with real-time pricing and component availability.

In most cases, these actions are available:

- Run electrical simulations to see important waveforms and circuit performance
- Run thermal simulations to understand board thermal performance
- Export customized schematic and layout into popular CAD formats
- Print PDF reports for the design, and share the design with colleagues

Get more information about WEBENCH tools at [www.ti.com/WEBENCH](http://www.ti.com/WEBENCH).

### 9.2 Receiving Notification of Documentation Updates

To receive notification of documentation updates, navigate to the device product folder on [ti.com](http://ti.com). Click on *Subscribe to updates* to register and receive a weekly digest of any product information that has changed. For change details, review the revision history included in any revised document.

### 9.3 Support Resources

[TI E2E™ support forums](#) are an engineer's go-to source for fast, verified answers and design help — straight from the experts. Search existing answers or ask your own question to get the quick design help you need.

Linked content is provided "AS IS" by the respective contributors. They do not constitute TI specifications and do not necessarily reflect TI's views; see TI's [Terms of Use](#).

### 9.4 Trademarks

SWIFT™, PowerPAD™, and TI E2E™ are trademarks of Texas Instruments.

WEBENCH® is a registered trademark of Texas Instruments.

All trademarks are the property of their respective owners.

### 9.5 Electrostatic Discharge Caution



This integrated circuit can be damaged by ESD. Texas Instruments recommends that all integrated circuits be handled with appropriate precautions. Failure to observe proper handling and installation procedures can cause damage.

ESD damage can range from subtle performance degradation to complete device failure. Precision integrated circuits may be more susceptible to damage because very small parametric changes could cause the device not to meet its published specifications.

### 9.6 Glossary

[TI Glossary](#) This glossary lists and explains terms, acronyms, and definitions.

## 10 Mechanical, Packaging, and Orderable Information

The following pages include mechanical, packaging, and orderable information. This information is the most current data available for the designated devices. This data is subject to change without notice and revision of this document. For browser-based versions of this data sheet, refer to the left-hand navigation.

**PACKAGING INFORMATION**

Orderable Device	Status (1)	Package Type	Package Drawing	Pins	Package Qty	Eco Plan (2)	Lead finish/ Ball material (6)	MSL Peak Temp (3)	Op Temp (°C)	Device Marking (4/5)	Samples
TPS54531DDA	ACTIVE	SO PowerPAD	DDA	8	75	RoHS & Green	NIPDAU   NIPDAUAG	Level-2-260C-1 YEAR	-40 to 85	54531	<a href="#">Samples</a>
TPS54531DDAR	ACTIVE	SO PowerPAD	DDA	8	2500	RoHS & Green	NIPDAU   NIPDAUAG	Level-2-260C-1 YEAR	-40 to 85	54531	<a href="#">Samples</a>

(1) The marketing status values are defined as follows:

**ACTIVE:** Product device recommended for new designs.

**LIFEBUY:** TI has announced that the device will be discontinued, and a lifetime-buy period is in effect.

**NRND:** Not recommended for new designs. Device is in production to support existing customers, but TI does not recommend using this part in a new design.

**PREVIEW:** Device has been announced but is not in production. Samples may or may not be available.

**OBSOLETE:** TI has discontinued the production of the device.

(2) **RoHS:** TI defines "RoHS" to mean semiconductor products that are compliant with the current EU RoHS requirements for all 10 RoHS substances, including the requirement that RoHS substance do not exceed 0.1% by weight in homogeneous materials. Where designed to be soldered at high temperatures, "RoHS" products are suitable for use in specified lead-free processes. TI may reference these types of products as "Pb-Free".

**RoHS Exempt:** TI defines "RoHS Exempt" to mean products that contain lead but are compliant with EU RoHS pursuant to a specific EU RoHS exemption.

**Green:** TI defines "Green" to mean the content of Chlorine (Cl) and Bromine (Br) based flame retardants meet JS709B low halogen requirements of <=1000ppm threshold. Antimony trioxide based flame retardants must also meet the <=1000ppm threshold requirement.

(3) MSL, Peak Temp. - The Moisture Sensitivity Level rating according to the JEDEC industry standard classifications, and peak solder temperature.

(4) There may be additional marking, which relates to the logo, the lot trace code information, or the environmental category on the device.

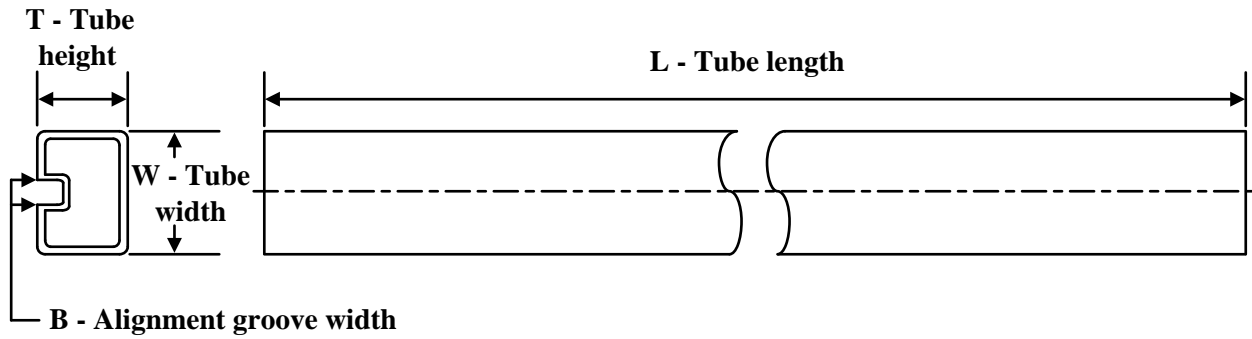
(5) Multiple Device Markings will be inside parentheses. Only one Device Marking contained in parentheses and separated by a "~" will appear on a device. If a line is indented then it is a continuation of the previous line and the two combined represent the entire Device Marking for that device.

(6) Lead finish/Ball material - Orderable Devices may have multiple material finish options. Finish options are separated by a vertical ruled line. Lead finish/Ball material values may wrap to two lines if the finish value exceeds the maximum column width.

**Important Information and Disclaimer:**The information provided on this page represents TI's knowledge and belief as of the date that it is provided. TI bases its knowledge and belief on information provided by third parties, and makes no representation or warranty as to the accuracy of such information. Efforts are underway to better integrate information from third parties. TI has taken and continues to take reasonable steps to provide representative and accurate information but may not have conducted destructive testing or chemical analysis on incoming materials and chemicals. TI and TI suppliers consider certain information to be proprietary, and thus CAS numbers and other limited information may not be available for release.

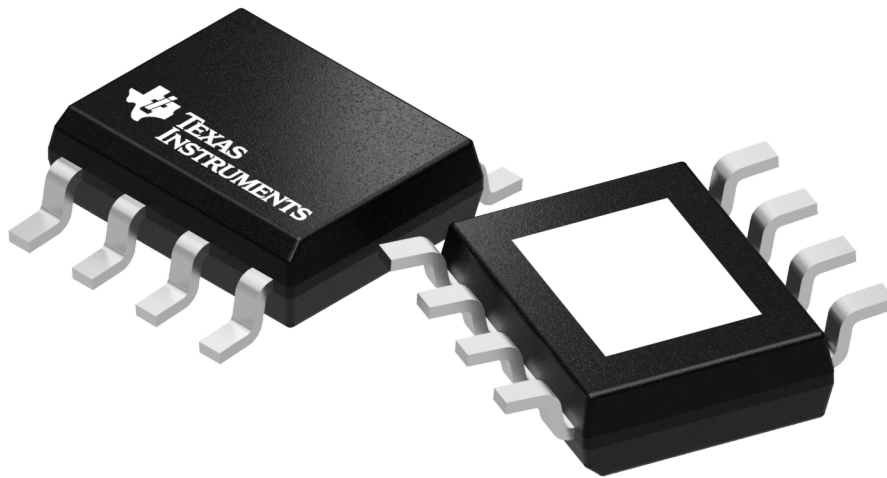
In no event shall TI's liability arising out of such information exceed the total purchase price of the TI part(s) at issue in this document sold by TI to Customer on an annual basis.



**TUBE**


\*All dimensions are nominal

Device	Package Name	Package Type	Pins	SPQ	L (mm)	W (mm)	T (μm)	B (mm)
TPS54531DDA	DDA	HSOIC	8	75	517	7.87	635	4.25
TPS54531DDA	DDA	HSOIC	8	75	507	8	3940	4.32



Images above are just a representation of the package family, actual package may vary.  
Refer to the product data sheet for package details.

# DDA0008B



# PACKAGE OUTLINE

## PowerPAD™ SOIC - 1.7 mm max height

PLASTIC SMALL OUTLINE



PowerPAD is a trademark of Texas Instruments.

### NOTES:

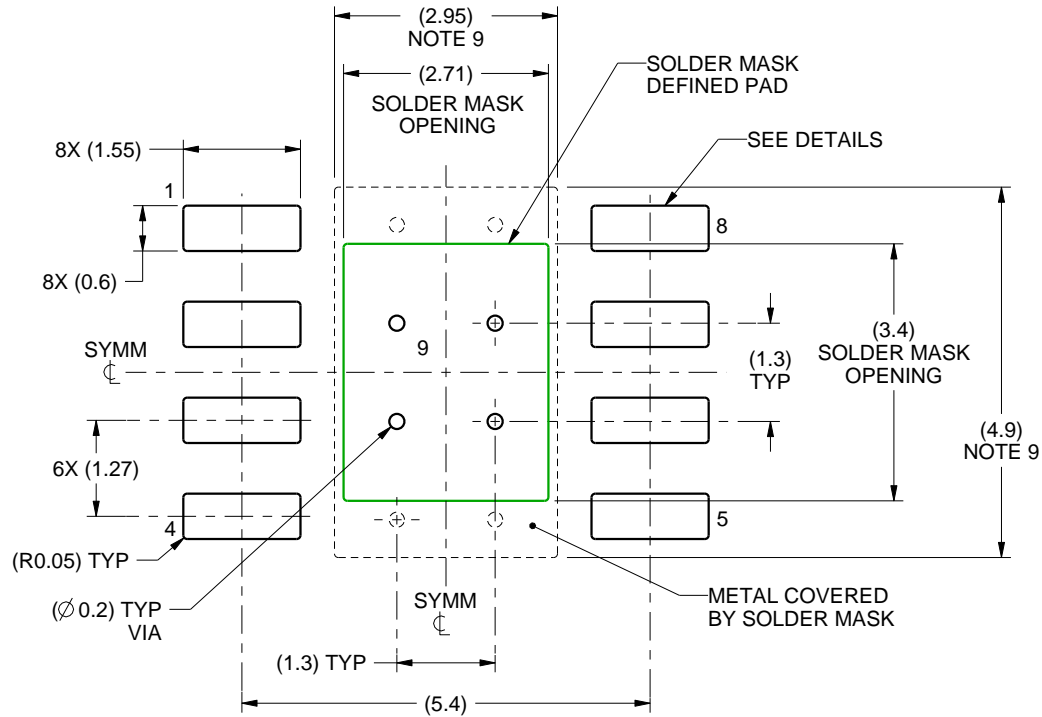
1. All linear dimensions are in millimeters. Any dimensions in parenthesis are for reference only. Dimensioning and tolerancing per ASME Y14.5M.
2. This drawing is subject to change without notice.
3. This dimension does not include mold flash, protrusions, or gate burrs. Mold flash, protrusions, or gate burrs shall not exceed 0.15 mm per side.
4. This dimension does not include interlead flash. Interlead flash shall not exceed 0.25 mm per side.
5. Reference JEDEC registration MS-012.

# EXAMPLE BOARD LAYOUT

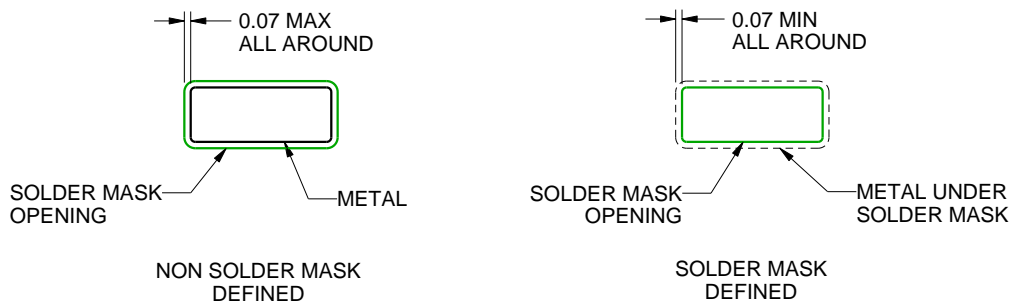
DDA0008B

PowerPAD™ SOIC - 1.7 mm max height

PLASTIC SMALL OUTLINE



LAND PATTERN EXAMPLE  
SCALE:10X



SOLDER MASK DETAILS  
PADS 1-8

4214849/A 08/2016

NOTES: (continued)

6. Publication IPC-7351 may have alternate designs.
7. Solder mask tolerances between and around signal pads can vary based on board fabrication site.
8. This package is designed to be soldered to a thermal pad on the board. For more information, see Texas Instruments literature numbers SLMA002 ([www.ti.com/lit/slma002](http://www.ti.com/lit/slma002)) and SLMA004 ([www.ti.com/lit/slma004](http://www.ti.com/lit/slma004)).
9. Size of metal pad may vary due to creepage requirement.
10. Vias are optional depending on application, refer to device data sheet. If any vias are implemented, refer to their locations shown on this view. It is recommended that vias under paste be filled, plugged or tented.

# EXAMPLE STENCIL DESIGN

DDA0008B

PowerPAD™ SOIC - 1.7 mm max height

PLASTIC SMALL OUTLINE



SOLDER PASTE EXAMPLE  
 EXPOSED PAD  
 100% PRINTED SOLDER COVERAGE BY AREA  
 SCALE:10X

STENCIL THICKNESS	SOLDER STENCIL OPENING
0.1	3.03 X 3.80
0.125	2.71 X 3.40 (SHOWN)
0.150	2.47 X 3.10
0.175	2.29 X 2.87

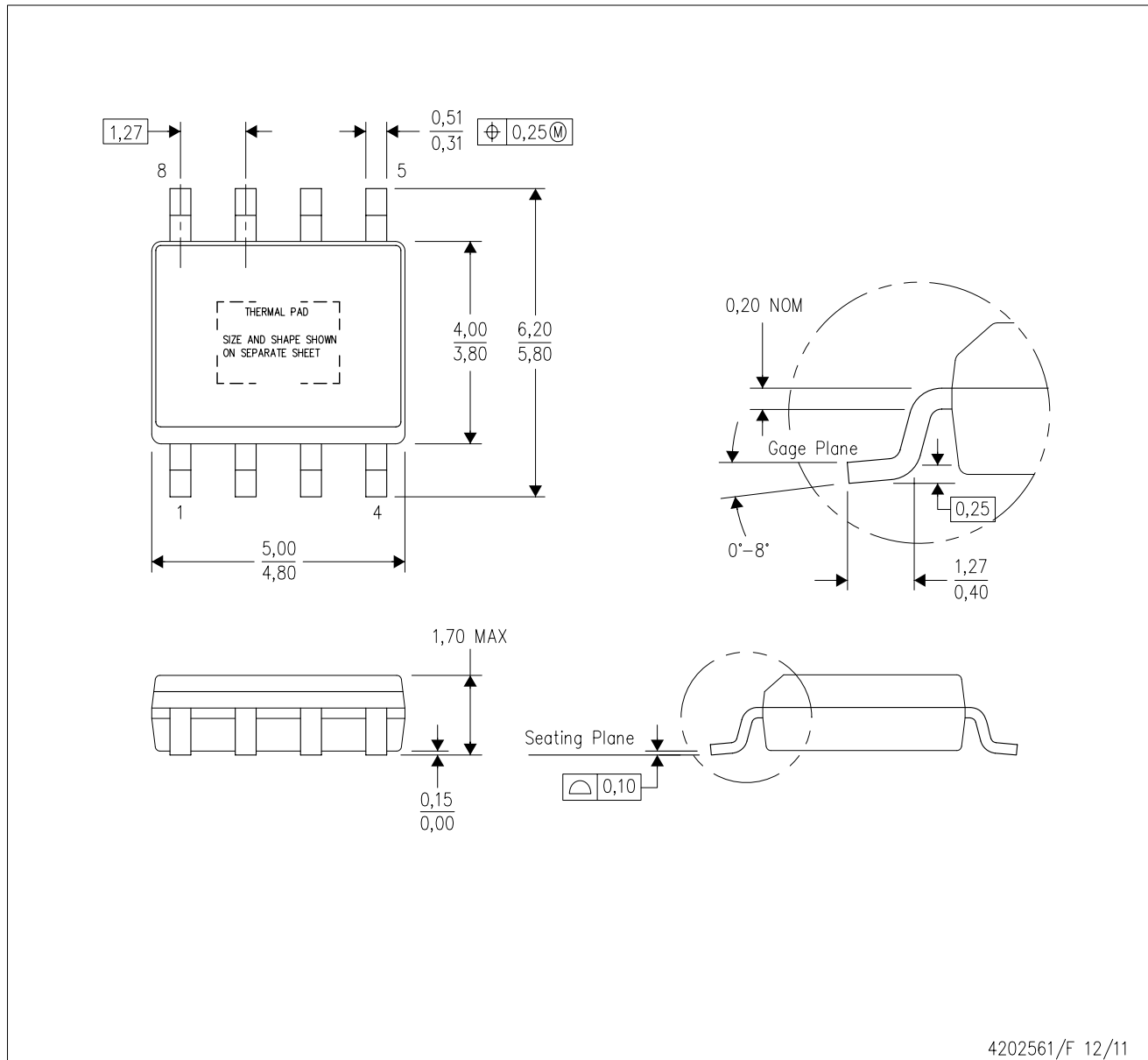
4214849/A 08/2016

NOTES: (continued)

11. Laser cutting apertures with trapezoidal walls and rounded corners may offer better paste release. IPC-7525 may have alternate design recommendations.
12. Board assembly site may have different recommendations for stencil design.

DDA (R-PDSO-G8)

PowerPAD™ PLASTIC SMALL-OUTLINE



4202561/F 12/11

- NOTES:
- All linear dimensions are in millimeters. Dimensioning and tolerancing per ASME Y14.5-1994.
  - This drawing is subject to change without notice.
  - Body dimensions do not include mold flash or protrusion not to exceed 0,15.
  - This package is designed to be soldered to a thermal pad on the board. Refer to Technical Brief, PowerPad Thermally Enhanced Package, Texas Instruments Literature No. SLMA002 for information regarding recommended board layout. This document is available at [www.ti.com](http://www.ti.com) <<http://www.ti.com>>.
  - See the additional figure in the Product Data Sheet for details regarding the exposed thermal pad features and dimensions.
  - This package complies to JEDEC MS-012 variation BA

PowerPAD is a trademark of Texas Instruments.

DDA (R-PDSO-G8)

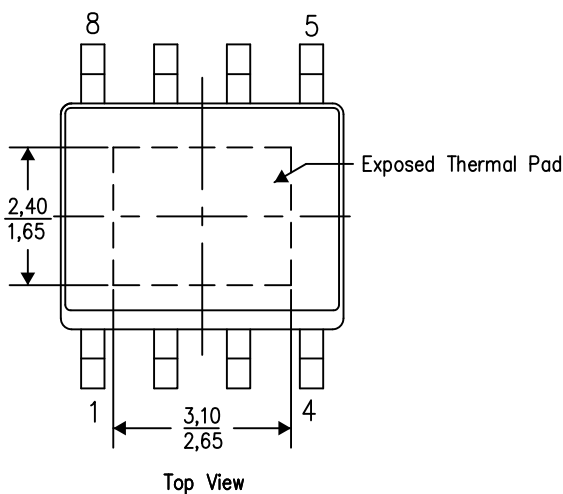
PowerPAD™ PLASTIC SMALL OUTLINE

## THERMAL INFORMATION

This PowerPAD™ package incorporates an exposed thermal pad that is designed to be attached to a printed circuit board (PCB). The thermal pad must be soldered directly to the PCB. After soldering, the PCB can be used as a heatsink. In addition, through the use of thermal vias, the thermal pad can be attached directly to the appropriate copper plane shown in the electrical schematic for the device, or alternatively, can be attached to a special heatsink structure designed into the PCB. This design optimizes the heat transfer from the integrated circuit (IC).

For additional information on the PowerPAD package and how to take advantage of its heat dissipating abilities, refer to Technical Brief, PowerPAD Thermally Enhanced Package, Texas Instruments Literature No. SLMA002 and Application Brief, PowerPAD Made Easy, Texas Instruments Literature No. SLMA004. Both documents are available at [www.ti.com](http://www.ti.com).

The exposed thermal pad dimensions for this package are shown in the following illustration.

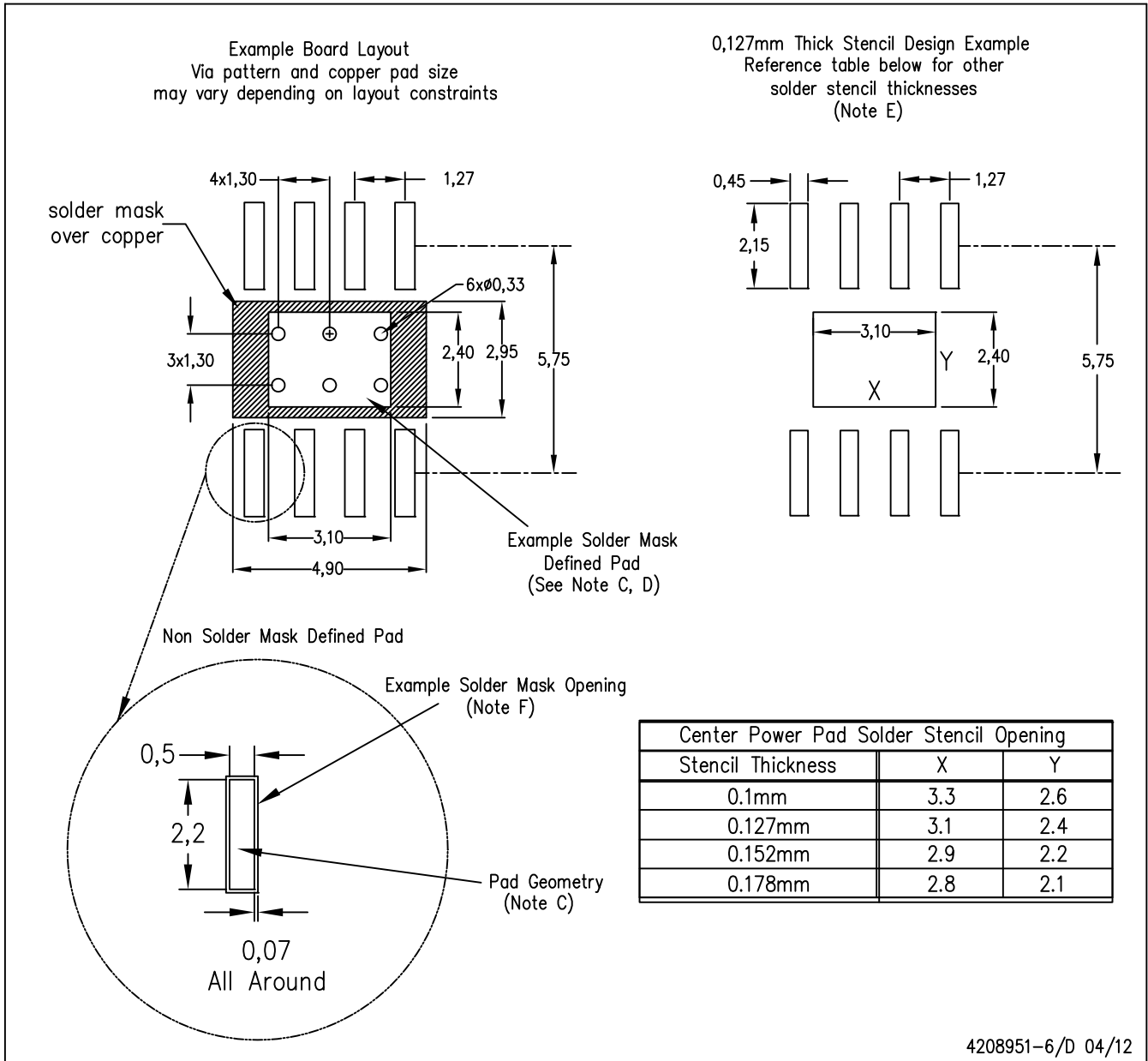


Exposed Thermal Pad Dimensions

4206322-6/L 05/12

NOTE: A. All linear dimensions are in millimeters

PowerPAD is a trademark of Texas Instruments



- NOTES:
- A. All linear dimensions are in millimeters.
  - B. This drawing is subject to change without notice.
  - C. Publication IPC-7351 is recommended for alternate designs.
  - D. This package is designed to be soldered to a thermal pad on the board. Refer to Technical Brief, PowerPad Thermally Enhanced Package, Texas Instruments Literature No. SLMA002, SLMA004, and also the Product Data Sheets for specific thermal information, via requirements, and recommended board layout. These documents are available at [www.ti.com](http://www.ti.com) <<http://www.ti.com>>. Publication IPC-7351 is recommended for alternate designs.
  - E. Laser cutting apertures with trapezoidal walls and also rounding corners will offer better paste release. Customers should contact their board assembly site for stencil design recommendations. Example stencil design based on a 50% volumetric metal load solder paste. Refer to IPC-7525 for other stencil recommendations.
  - F. Customers should contact their board fabrication site for solder mask tolerances between and around signal pads.

PowerPAD is a trademark of Texas Instruments.

## IMPORTANT NOTICE AND DISCLAIMER

TI PROVIDES TECHNICAL AND RELIABILITY DATA (INCLUDING DATA SHEETS), DESIGN RESOURCES (INCLUDING REFERENCE DESIGNS), APPLICATION OR OTHER DESIGN ADVICE, WEB TOOLS, SAFETY INFORMATION, AND OTHER RESOURCES "AS IS" AND WITH ALL FAULTS, AND DISCLAIMS ALL WARRANTIES, EXPRESS AND IMPLIED, INCLUDING WITHOUT LIMITATION ANY IMPLIED WARRANTIES OF MERCHANTABILITY, FITNESS FOR A PARTICULAR PURPOSE OR NON-INFRINGEMENT OF THIRD PARTY INTELLECTUAL PROPERTY RIGHTS.

These resources are intended for skilled developers designing with TI products. You are solely responsible for (1) selecting the appropriate TI products for your application, (2) designing, validating and testing your application, and (3) ensuring your application meets applicable standards, and any other safety, security, regulatory or other requirements.

These resources are subject to change without notice. TI grants you permission to use these resources only for development of an application that uses the TI products described in the resource. Other reproduction and display of these resources is prohibited. No license is granted to any other TI intellectual property right or to any third party intellectual property right. TI disclaims responsibility for, and you will fully indemnify TI and its representatives against, any claims, damages, costs, losses, and liabilities arising out of your use of these resources.

TI's products are provided subject to [TI's Terms of Sale](#) or other applicable terms available either on [ti.com](https://www.ti.com) or provided in conjunction with such TI products. TI's provision of these resources does not expand or otherwise alter TI's applicable warranties or warranty disclaimers for TI products.

TI objects to and rejects any additional or different terms you may have proposed.

Mailing Address: Texas Instruments, Post Office Box 655303, Dallas, Texas 75265  
Copyright © 2023, Texas Instruments Incorporated

## Looking for pricing, stock, or lifecycle information?

Click below to explore more details on WIN SOURCE:

 [View TPS54531DDAR](#) on WIN SOURCE

 [Texas Instruments](#) Information

## Optimize Your Supply Chain with WIN SOURCE Solutions

-  Global Sourcing Solution
-  Obsolete Management
-  Cost Control Management
-  Shortage Management
-  Alternative Solution
-  Excess Inventory Management