

TPS60110 REGULATED 5-V 300-mA LOW-NOISE CHARGE PUMP DC/DC CONVERTER

SLVS215C – JUNE 1999 – REVISED AUGUST 2008

features

- Up to 300-mA Output Current
- Less Than 10-mV_{pp} Output Voltage Ripple
- No Inductors Required/Low EMI
- Regulated 5-V ±4% Output
- Only Four External Components Required
- Up to 90% Efficiency
- 2.7-V to 5.4-V Input Voltage Range
- 60-μA Quiescent Supply Current
- 0.05-μA Shutdown Current
- Load Isolated in Shutdown
- Space-Saving Thermally-Enhanced TSSOP PowerPAD™ Package
- Evaluation Module Available (TPS60110EVM-132)

description

The TPS60110 step-up, regulated charge pump generates a 5-V ±4% output voltage from a 2.7-V to 5.4-V input voltage (three alkaline, NiCd, or NiMH batteries; or, one lithium or lithium ion battery). Output current is 300 mA from a 3-V input. Only four external capacitors are needed to build a complete low-noise dc/dc converter. The push-pull operating mode of two single-ended charge pumps assures the low output voltage ripple as current is continuously transferred to the output. From a 3-V input, the TPS60110 can start into full load with loads as low as 16 Ω.

The TPS60110 features either constant frequency mode to minimize noise and output voltage ripple or the power-saving pulse-skip mode to extend battery life at light loads. The TPS60110 switching frequency is 300 kHz. The logic shutdown function reduces the supply current to 1-μA (max) and disconnects the load from the input. Special current-control circuitry prevents excessive current from being drawn from the battery during start-up. This dc/dc converter requires no inductors and has low EMI. It is available in the small 20-pin TSSOP PowerPAD™ package (PWP).

applications

- Replaces DC/DC Converters With Inductors in
 - Battery-Powered Applications
 - Li-Ion Battery to 5-V Conversion
 - Portable Instruments
 - Battery-Powered Microprocessor Systems
 - Miniature Equipment
 - Backup-Battery Boost Converters
 - PDAs
 - Laptops
 - Handheld Instrumentation
 - Medical Instruments

output voltage ripple

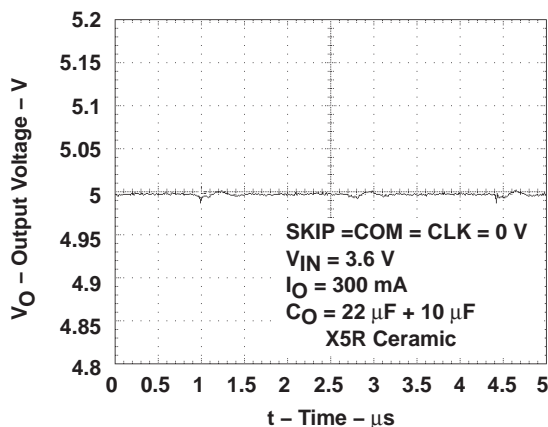

typical operating circuit

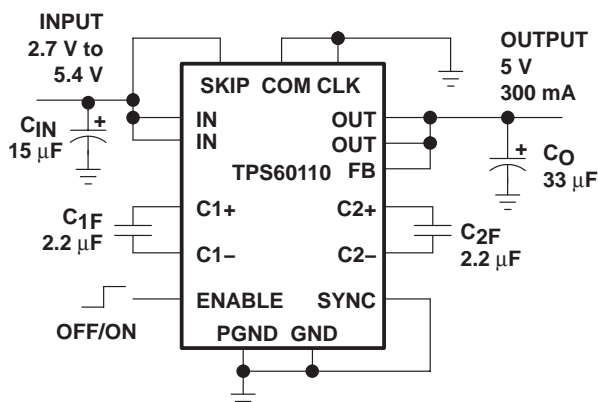

Figure 1



Please be aware that an important notice concerning availability, standard warranty, and use in critical applications of Texas Instruments semiconductor products and disclaimers thereto appears at the end of this data sheet.

PowerPAD is a trademark of Texas Instruments.

PRODUCTION DATA information is current as of publication date. Products conform to specifications per the terms of Texas Instruments standard warranty. Production processing does not necessarily include testing of all parameters.



POST OFFICE BOX 655303 • DALLAS, TEXAS 75265

Copyright © 1999–2003 Texas Instruments Incorporated

TPS60110 REGULATED 5-V 300-mA LOW-NOISE CHARGE PUMP DC/DC CONVERTER

SLVS215C – JUNE 1999 – REVISED AUGUST 2008

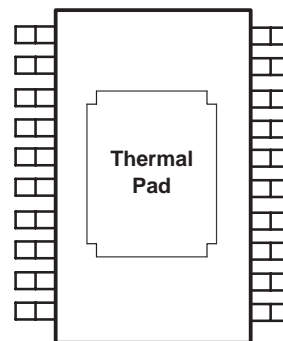
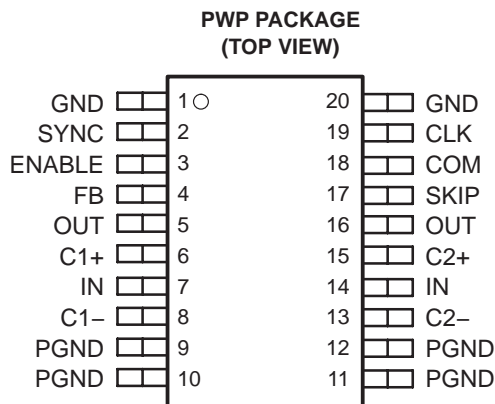

Figure 2. Bottom View of PWP Package, Showing the Thermal Pad

AVAILABLE OPTIONS

PACKAGE
TSSOP† (PWP)
TPS60110PWP

† This package is available taped and reeled. To order this packaging option, add an R suffix to the part number (e.g., TPS60110PWPR).

Terminal Functions

TERMINAL NAME	NO.	I/O	DESCRIPTION
CLK	19	I	Input for external clock signal. If the internal clock is used, connect this terminal to GND.
C1+	6		Positive terminal of the charge-pump capacitor C _{1F}
C1-	8		Negative terminal of the charge-pump capacitor C _{1F}
C2+	15		Positive terminal of the charge-pump capacitor C _{2F}
C2-	13		Negative terminal of the charge-pump capacitor C _{2F}
COM	18	I	Mode selection. When COM is logic low the charge pump operates in push-pull mode to minimize output ripple. When COM is connected to IN the regulator operates in single-ended mode requiring only one flying capacitor.
ENABLE	3	I	ENABLE Input. The device turns off, the output disconnects from the input, and the supply current decreases to 0.05 μA when ENABLE is a logic low. ENABLE High may only be applied when VIN is inside the recommended operating range.
FB	4	I	FEEDBACK input. Connect FB to OUT as close to the load as possible to achieve best regulation. Resistive divider is on-chip to match internal reference voltage of 1.22 V.
GND	1, 20		GROUND. Analog ground for internal reference and control circuitry. Connect to PGND through a short trace.
IN	7, 14	I	Supply Input. Connect to an input supply in the 2.7-V to 5.4-V range. Bypass IN to GND with a (C _O /2) μF capacitor. Connect both INs through a short trace.
OUT	5, 16	O	Regulated 5-V power output. Connect both OUTs through a short trace and bypass OUT to GND with the output filter capacitor C _O .
PGND	9–12		PGND power ground. Charge-pump current flows through this pin. Connect all PGNDs together.
SKIP	17	I	Mode selection. When SKIP is logic low, the charge pump operates in constant-frequency mode. Output ripple and noise are minimized in this mode. When SKIP is connect to IN, the device operates in pulse skip mode. Quiescent current is lowest in this mode.
SYNC	2	I	Selection for external clock signal. Connect to GND to use the internally generated clock signal. Connect to IN for external synchronization. In this case, the clock signal needs to be fed through CLK.
PowerPAD™			Must be soldered to achieve appropriate power dissipation. Should be connected to PGND.

TPS60110
REGULATED 5-V 300-mA LOW-NOISE
CHARGE PUMP DC/DC CONVERTER

SLVS215C – JUNE 1999 – REVISED AUGUST 2008

absolute maximum ratings (unless otherwise noted)†‡

Input voltage range, V_I (IN, OUT, ENABLE, SKIP, COM, CLK, FB, SYNC)	–0.3 V to 5.5 V
Differential input voltage, V_{ID} (C1+, C2+ to GND)	–0.3 V to (V_O + 0.3 V)
Differential input voltage, V_{ID} (C1–, C2– to GND)	–0.3 V to (V_{IN} + 0.3 V)
Continuous total power dissipation	See Dissipation Rating Tables
Continuous output current	400 mA
Storage temperature range, T_{stg}	–55°C to 150°C
Lead temperature 1,6 mm (1/16 inch) from case for 10s	260°C
Maximum junction temperature, T_J	150°C

† Stresses beyond those listed under “absolute maximum ratings” may cause permanent damage to the device. These are stress ratings only, and functional operation of the device at these or any other conditions beyond those indicated under “recommended operating conditions” is not implied. Exposure to absolute-maximum-rated conditions for extended periods may affect device reliability.

‡ V_{ENABLE} , V_{SKIP} , V_{COM} , V_{CLK} and V_{SYNC} can exceed V_{IN} up to the maximum rated voltage without increasing the leakage current drawn by these mode select inputs.

PACKAGE DISSIPATION RATINGS

PACKAGE	$T_A \leq 25^\circ\text{C}$ POWER RATING	DERATING FACTOR ABOVE $T_A = 25^\circ\text{C}$ §	$T_A = 70^\circ\text{C}$ POWER RATING	$T_A = 85^\circ\text{C}$ POWER RATING
PWP	3 W	30.3 mW/°C	1.66 W	1.21 W

§ The thermal resistance junction to ambient of the 20-pin TSSOP PowerPAD™ package $R_{\theta JA} = 33^\circ\text{C/W}$ (soldered PowerPAD using thermal vias). PowerPAD packages are modeled and tested using PWB boards recommended in the PowerPAD Application Report, SLMA0002. PowerPAD packages are designed for board mounting with the die pad soldered to a copper pad patterned on the board.



TPS60110
REGULATED 5-V 300-mA LOW-NOISE
CHARGE PUMP DC/DC CONVERTER

SLVS215C – JUNE 1999 – REVISED AUGUST 2008

electrical characteristics at $C_{IN} = 15 \mu\text{F}$, $C_{1F} = C_{2F} = 2.2 \mu\text{F}^\dagger$, $C_O = 33 \mu\text{F}$, $T_C = -40^\circ\text{C}$ to 85°C , $V_{IN} = 3\text{V}$, $V_{FB} = V_O$, $V_{ENABLE} = V_{IN}$, $V_{SKIP} = V_{IN}$ or 0V and $V_{COM} = V_{CLK} = V_{SYNC} = 0\text{V}$ (unless otherwise noted)

PARAMETER		TEST CONDITIONS	MIN	TYP	MAX	UNIT
V_{IN}	Input voltage		2.7		5.4	V
$I_O(\text{MAX})$	Maximum output current		300			mA
V_O	Output voltage	$2.7\text{V} < V_{IN} < 3\text{V}$, $V_O(\text{Start-Up}) = 5\text{V}$, $0 < I_O < 150\text{mA}$, $T_C = 25^\circ\text{C}$	4.8	5	5.2	V
		$3\text{V} < V_{IN} < 5\text{V}$, $0 < I_O < 300\text{mA}$	4.8	5	5.2	
		$5\text{V} < V_{IN} < 5.4\text{V}$, $0 < I_O < 300\text{mA}$	4.8	5	5.25	
$V_O(\text{RIP})$	Output voltage ripple	$I_O = 300\text{mA}$, $V(\text{SKIP}) = 0\text{V}$		10^\ddagger		mV _{PP}
$I_O(\text{LEAK})$	Output leakage current	$V_{IN} = 3.6\text{V}$, $V(\text{ENABLE}) = 0\text{V}$			1	μA
I_Q	Quiescent current (no-load input current)	$V(\text{SKIP}) = V_{IN} = 3.6\text{V}$		60	90	μA
		$V(\text{SKIP}) = 0\text{V}$, $V_{IN} = 3.6\text{V}$		2.8		mA
$I_{DD}(\text{SDN})$	Shutdown supply current	$V_{IN} = 3.6\text{V}$, $V(\text{ENABLE}) = 0\text{V}$		0.05	1	μA
$f_{\text{OSC(int)}}$	Internal switching frequency	$V_{IN} = 3.6\text{V}$	200	300	400	kHz
$f_{\text{OSC(ext)}}$	External clock frequency	$V(\text{SYNC}) = V_{IN}$, $V_{IN} = 2.7\text{V}$ to 5.4V	400	600	800	kHz
	External clock duty cycle	$V(\text{SYNC}) = V_{IN}$, $V_{IN} = 2.7\text{V}$ to 5.4V	20%		80%	
	Efficiency	$I_O = 150\text{mA}$		80%		
V_{INL}	Input voltage low, ENABLE, SKIP, COM, CLK, SYNC	$V_{IN} = 2.7\text{V}$			$0.3 \times V_{IN}$	V
V_{INH}	Input voltage high, ENABLE, SKIP, COM, CLK, SYNC	$V_{IN} = 5.4\text{V}$	$0.7 \times V_{IN}$			V
$I_I(\text{LEAK})$	Input leakage current, ENABLE, SKIP, COM, CLK, SYNC	$V(\text{ENABLE}) = V(\text{SKIP}) = V(\text{COM}) = V(\text{CLK}) = V(\text{SYNC}) = V(\text{GND})$ or V_{IN}		0.01	0.1	μA
	Output load regulation	$V_O = 5\text{V}$, $1\text{mA} < I_O < 300\text{mA}$, $T_C = 25^\circ\text{C}$		0.002		%/mA
	Output line regulation	$3\text{V} < V_{IN} < 5\text{V}$, $I_O = 150\text{mA}$, $V_O = 5\text{V}$, $T_C = 25^\circ\text{C}$		0.6		%/V
	Short circuit current	$V_{IN} = 3.6\text{V}$, $V_O = 0\text{V}$, $T_C = 25^\circ\text{C}$		150		mA

[†] Use only ceramic capacitors with X5R or X7R dielectric as flying capacitors.

[‡] Achieved with $C_O = 22 \mu\text{F} + 10 \mu\text{F}$ X5R dielectric ceramic capacitor



TYPICAL CHARACTERISTICS†

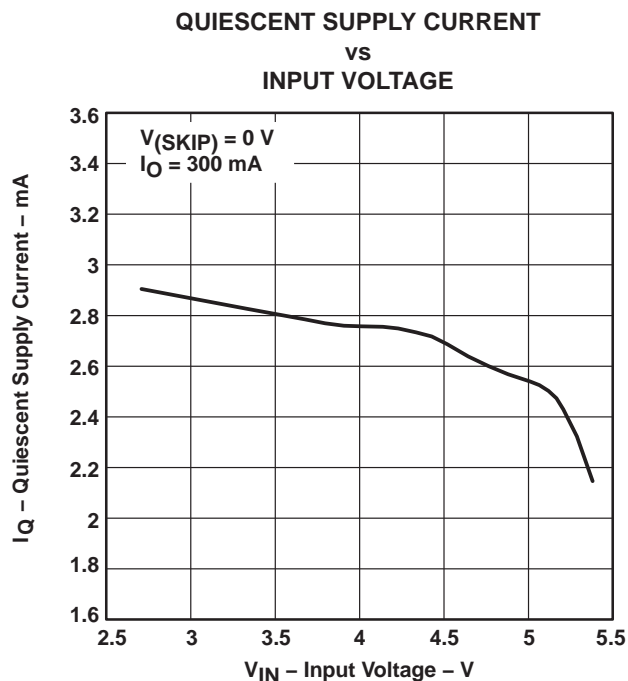
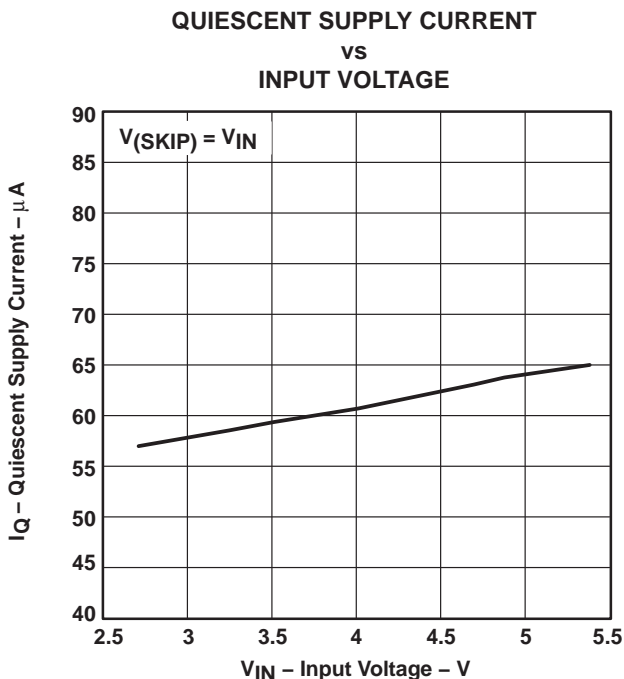
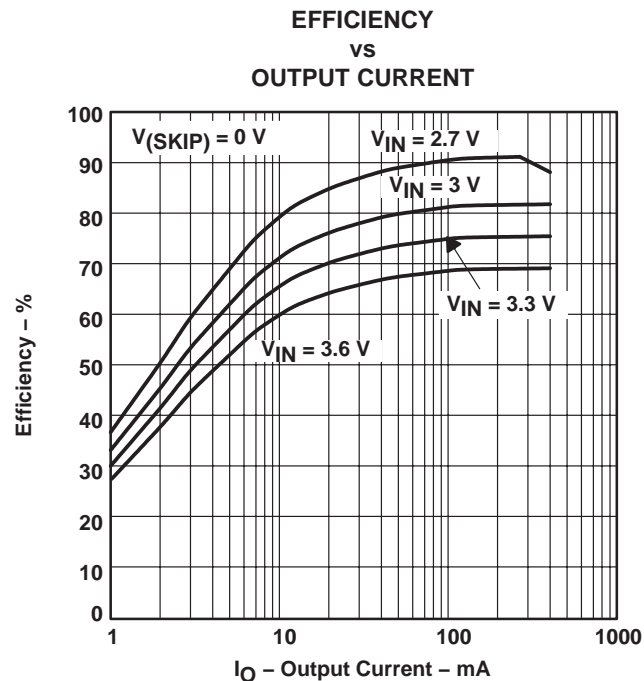
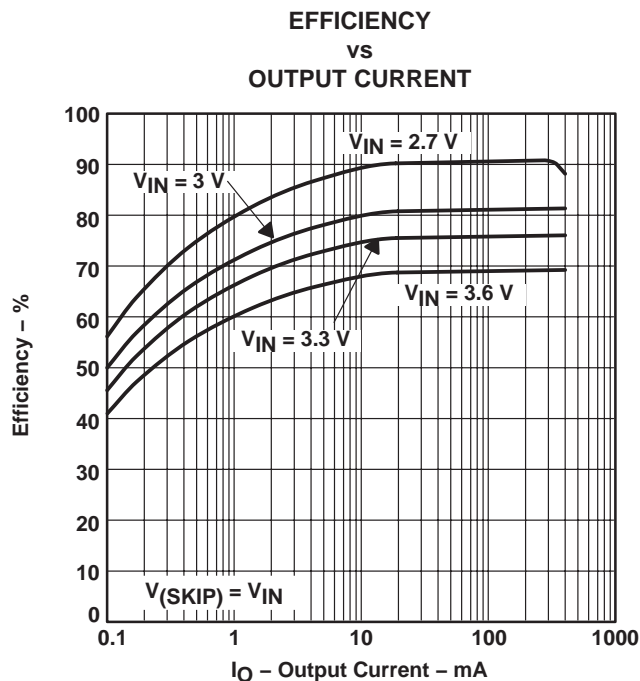

† $T_C = 25^\circ\text{C}$, $V_{\text{COM}} = V_{\text{SYNC}} = 0\text{ V}$, $C_{\text{IN}} = 15\ \mu\text{F}$, $C_{1\text{F}} = C_{2\text{F}} = 2.2\ \mu\text{F}$, $C_{\text{O}} = 33\ \mu\text{F}$, unless otherwise noted

TPS60110
REGULATED 5-V 300-mA LOW-NOISE
CHARGE PUMP DC/DC CONVERTER

SLVS215C – JUNE 1999 – REVISED AUGUST 2008

TYPICAL CHARACTERISTICS†

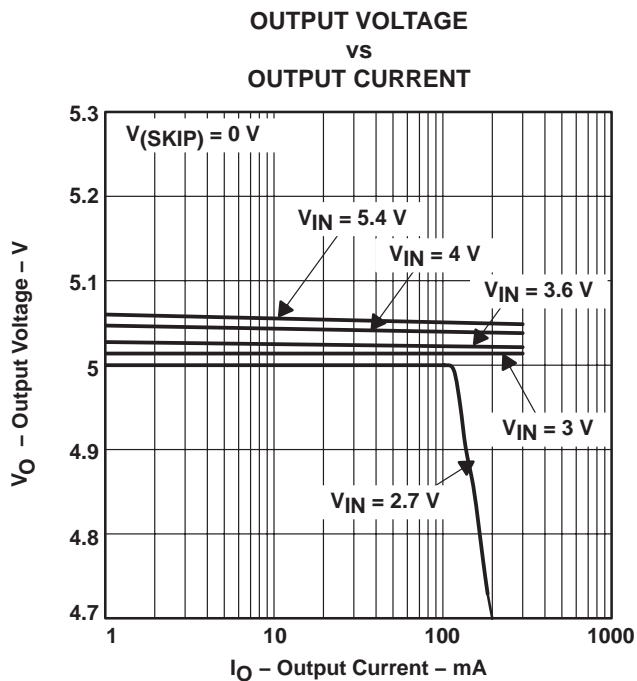

Figure 7

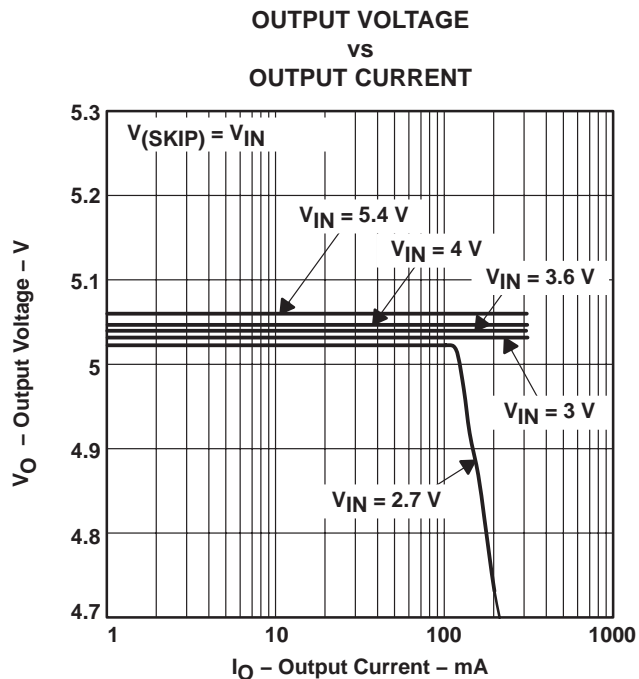

Figure 8

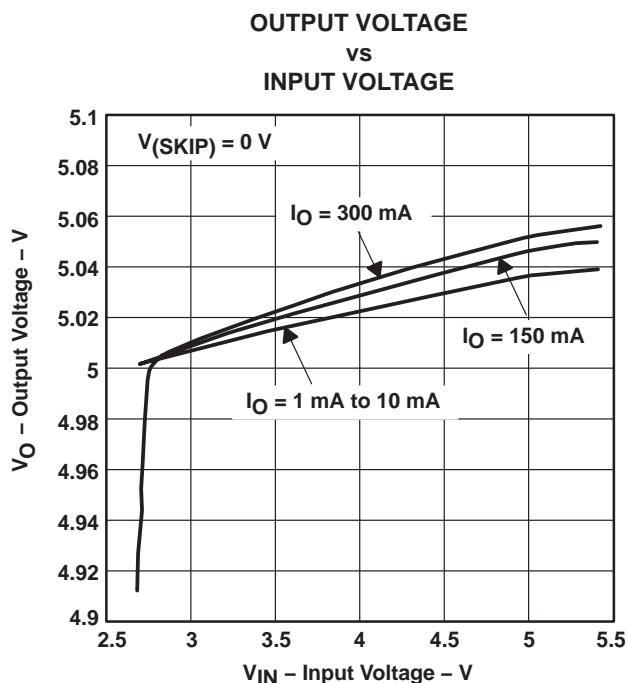

Figure 9

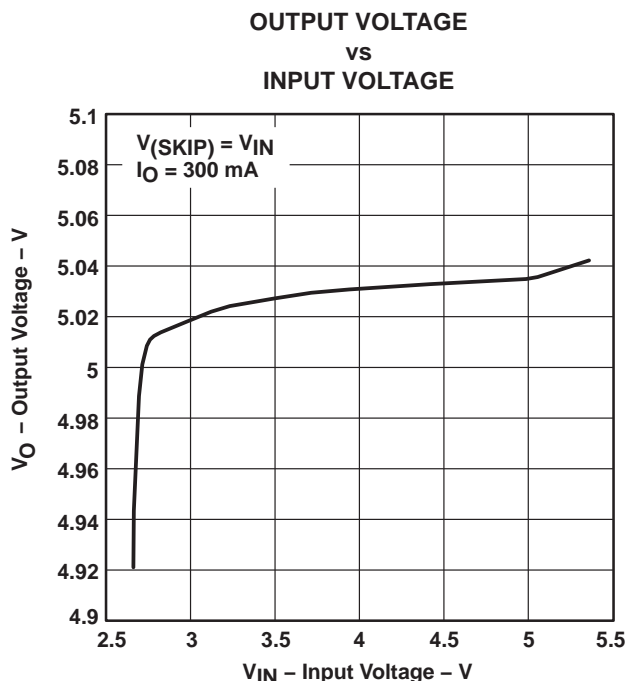

Figure 10

† $T_C = 25^\circ\text{C}$, $V_{\text{COM}} = V_{\text{SYNC}} = 0\text{ V}$, $C_{\text{IN}} = 15\ \mu\text{F}$, $C_{1\text{F}} = C_{2\text{F}} = 2.2\ \mu\text{F}$, $C_O = 33\ \mu\text{F}$, unless otherwise noted



TYPICAL CHARACTERISTICS†

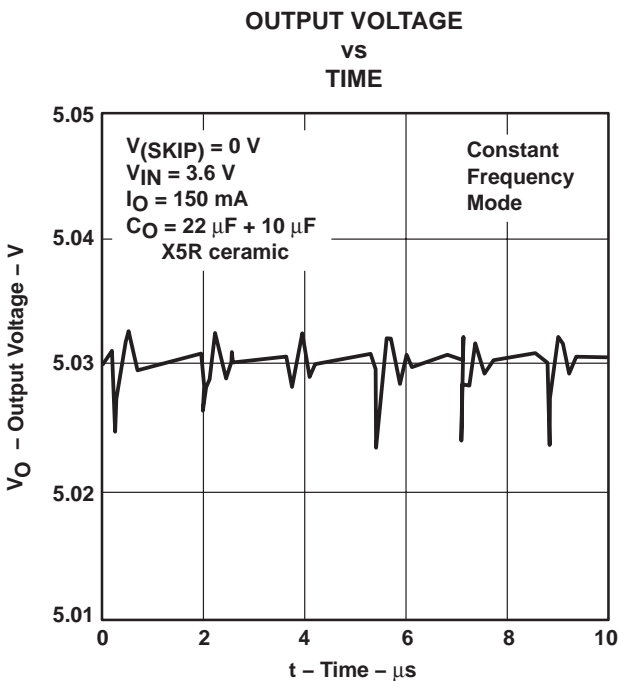

Figure 11

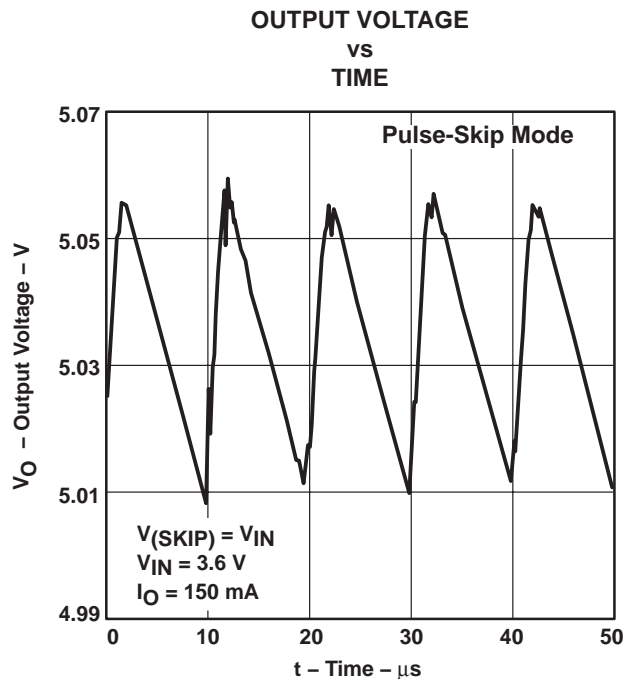

Figure 12

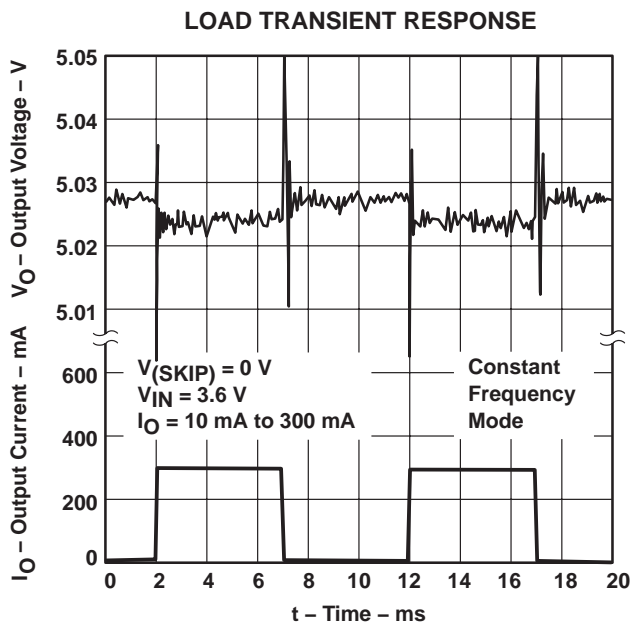

Figure 13

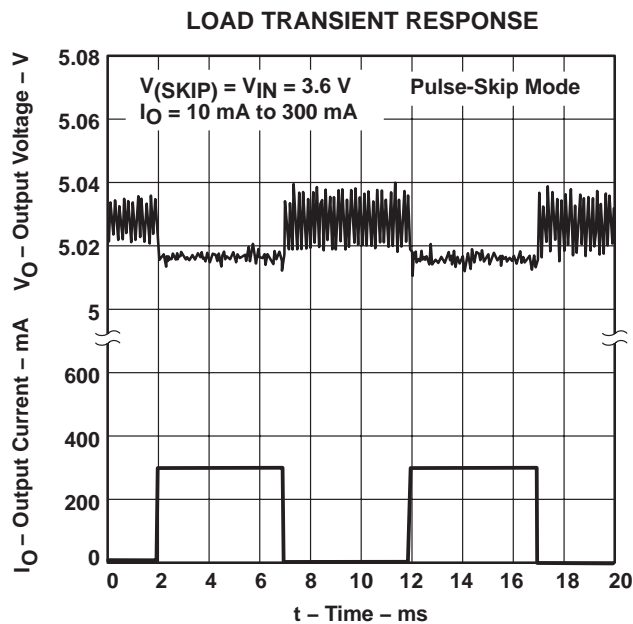

Figure 14

† $T_{\text{C}} = 25^{\circ}\text{C}$, $V_{\text{COM}} = V_{\text{SYNC}} = 0 \text{ V}$, $C_{\text{IN}} = 15 \mu\text{F}$, $C_{1\text{F}} = C_{2\text{F}} = 2.2 \mu\text{F}$, $C_{\text{O}} = 33 \mu\text{F}$, unless otherwise noted

TPS60110
REGULATED 5-V 300-mA LOW-NOISE
CHARGE PUMP DC/DC CONVERTER

SLVS215C – JUNE 1999 – REVISED AUGUST 2008

TYPICAL CHARACTERISTICS†

LINE TRANSIENT RESPONSE

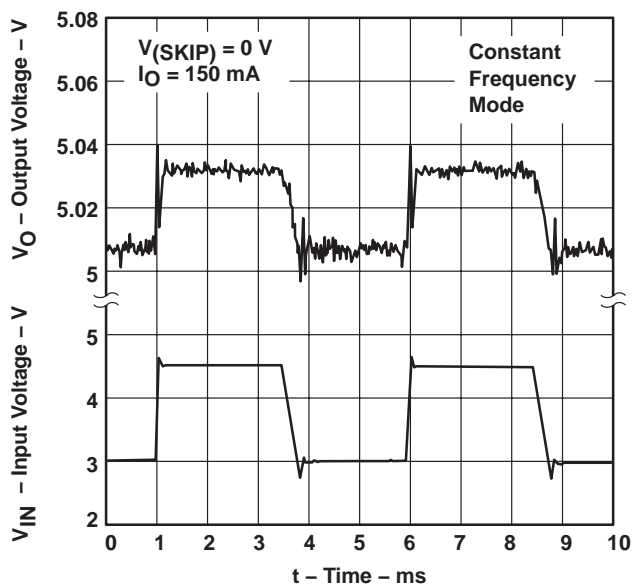

Figure 15

LINE TRANSIENT RESPONSE

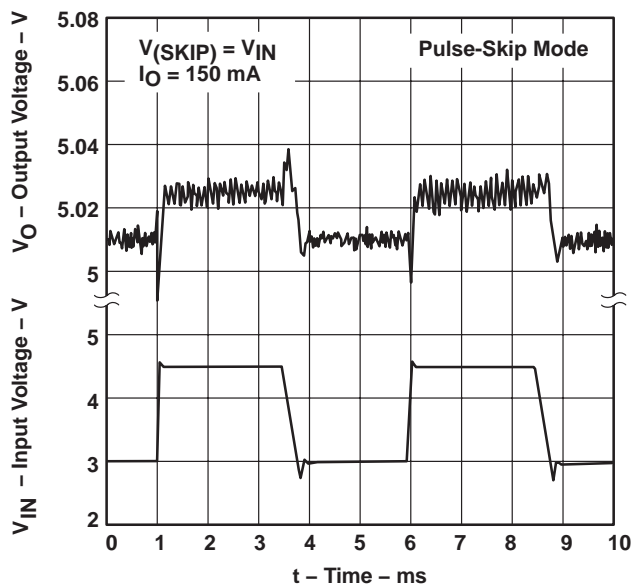

Figure 16

FREQUENCY SPECTRUM
CONSTANT FREQUENCY MODE‡

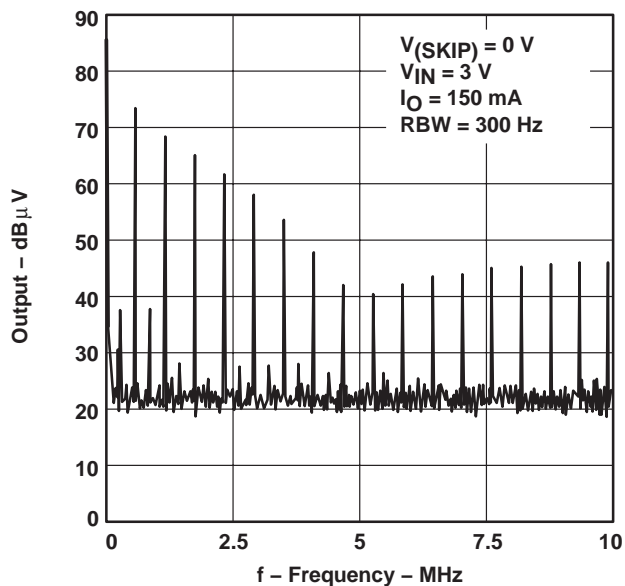

Figure 17

FREQUENCY SPECTRUM
PULSE-SKIP MODE‡

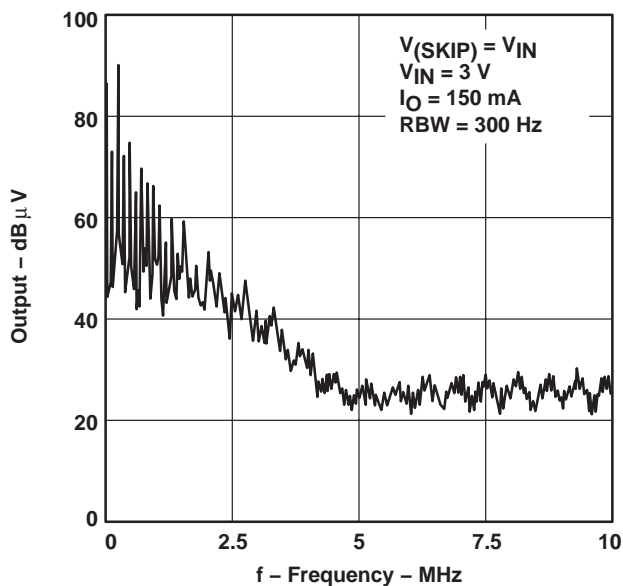

Figure 18

† $T_C = 25^\circ\text{C}$, $V_{COM} = V_{SYNC} = 0 \text{ V}$, $C_{IN} = 15 \mu\text{F}$, $C_{1F} = C_{2F} = 2.2 \mu\text{F}$, $C_O = 33 \mu\text{F}$, unless otherwise noted

‡ Test circuit: TPS60110EVM-132

TYPICAL CHARACTERISTICS†

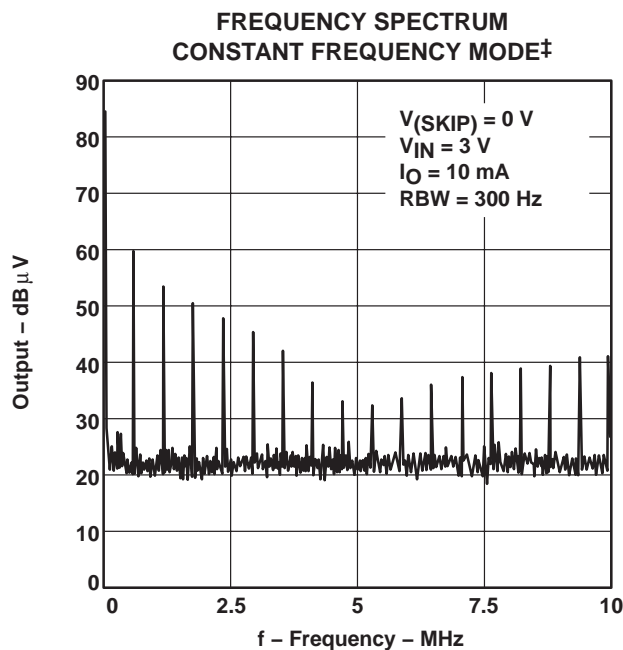

Figure 19

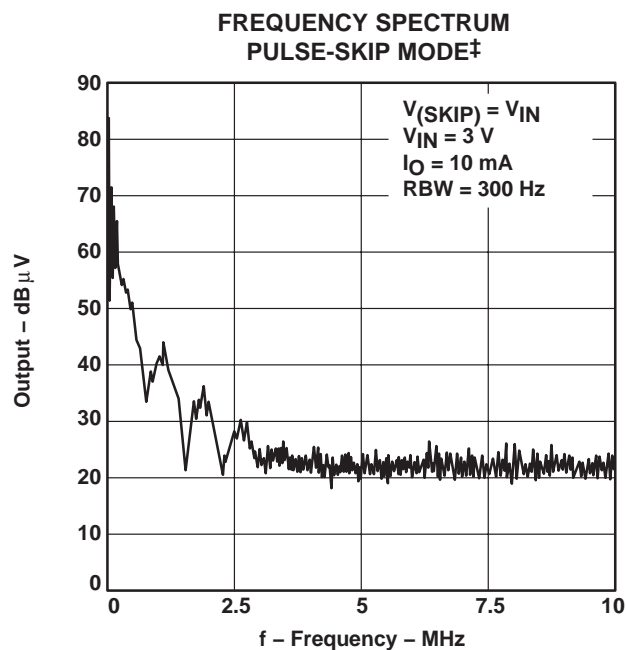

Figure 20

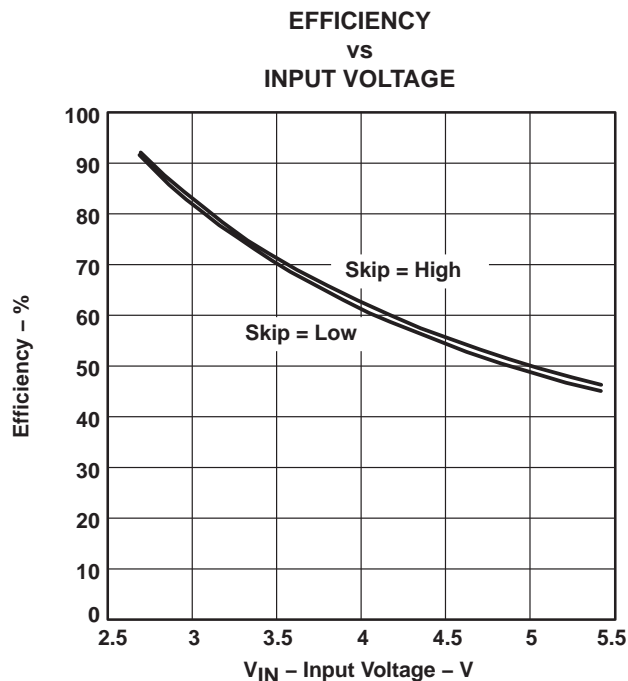

Figure 21

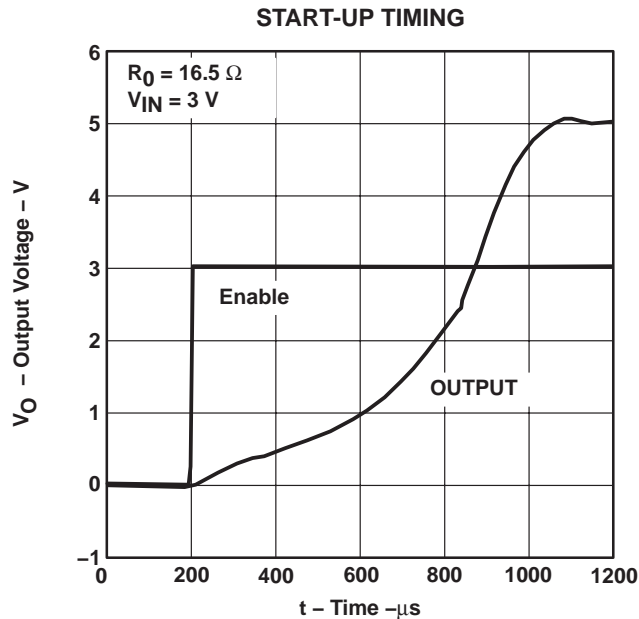

Figure 22

† $T_{\text{C}} = 25^{\circ}\text{C}$, $V_{\text{COM}} = V_{\text{SYNC}} = 0 \text{ V}$, $C_{\text{IN}} = 15 \mu\text{F}$, $C_{1\text{F}} = C_{2\text{F}} = 2.2 \mu\text{F}$, $C_{\text{O}} = 33 \mu\text{F}$, unless otherwise noted

‡ Test circuit: TPS60110EVM-132

TPS60110 REGULATED 5-V 300-mA LOW-NOISE CHARGE PUMP DC/DC CONVERTER

SLVS215C – JUNE 1999 – REVISED AUGUST 2008

detailed description

operating principle

The TPS60110 charge pump provides a regulated 5-V output from a 2.7-V to 5.4-V input. It delivers a maximum load current of 300 mA. Designed specifically for space critical battery powered applications, the complete charge pump circuit requires only four external capacitors. The circuit can be optimized for highest efficiency at light loads or lowest output noise. The TPS60110 consists of an oscillator, a 1.22-V bandgap reference, an internal resistive feedback circuit, an error amplifier, high current MOSFET switches, a shutdown/start-up circuit, and a control circuit (Figure 23)

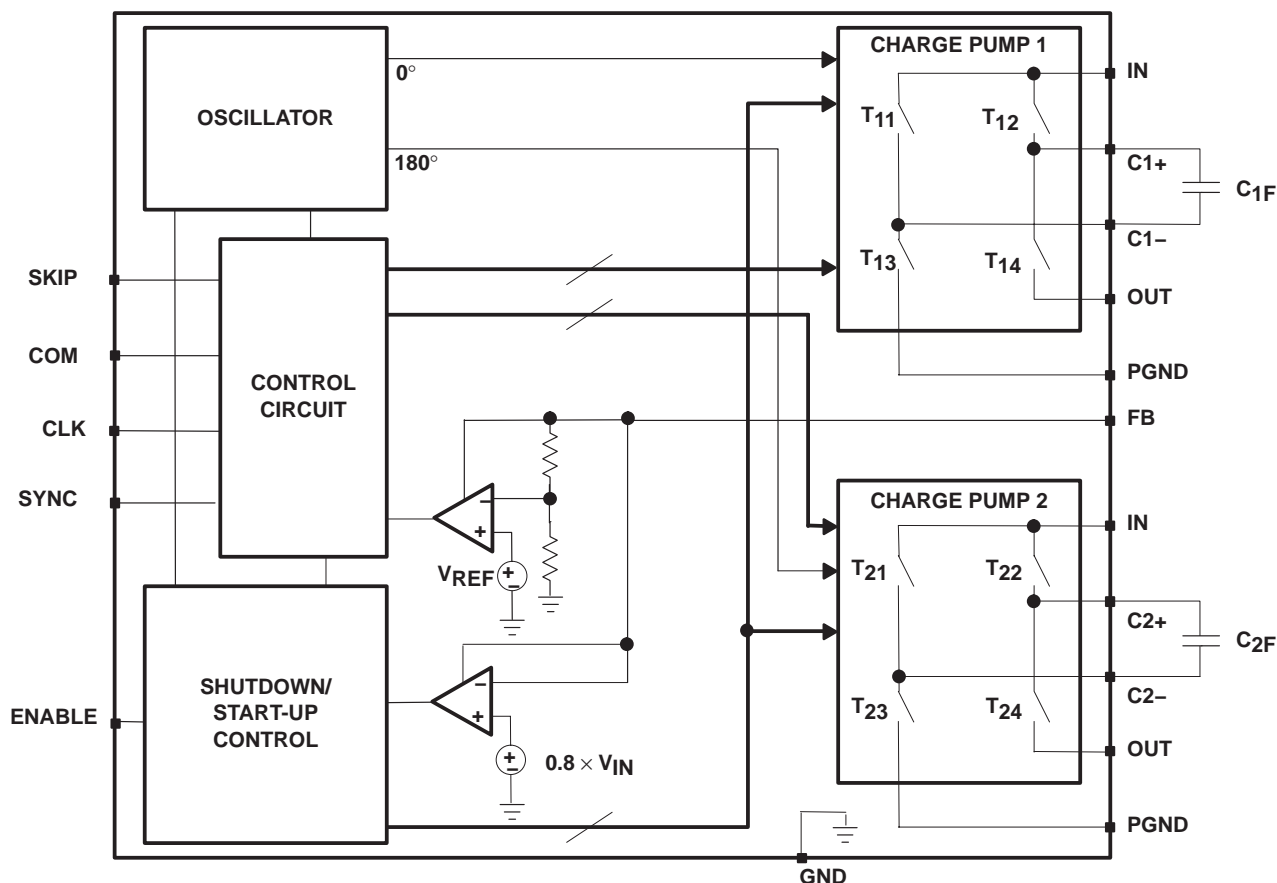

Figure 23. Functional Block Diagram TPS60110

The oscillator runs at a 50% duty cycle. The device consists of two single-ended charge pumps which operate with 180° phase shift. Each single ended charge pump transfers charge into its transfer capacitor (C_{XF}) in one half of the period. During the other half of the period (transfer phase), C_{XF} is placed in series with the input to transfer its charge to C_O . While one single-ended charge pump is in the charge phase, the other one is in the transfer phase. This operation specifies an almost constant output current which ensures a low output ripple.

If the clock were to run continuously, this process would eventually generate an output voltage equal to two times the input voltage (hence the name doubler). In order to provide a regulated fixed output voltage of 5 V, the TPS60110 uses either pulse-skip mode or constant-frequency mode. Pulse-skip mode and constant-frequency mode are externally selected via the SKIP input pin.

detailed description (continued)

start-up procedure

During start-up, i.e. when ENABLE is set from logic low to logic high, the switches T12 and T14 (charge pump 1), and the switches T22 and T24 (charge pump 2) are conducting to charge up the output capacitor until the output voltage V_O reaches $0.8 \times V_{IN}$. When the start-up comparator detects this limit, the IC begins to operate in the mode selected with SKIP and COM. This start-up charging of the output capacitor specifies a short start-up time and eliminates the need for a Schottky diode between IN and OUT.

pulse-skip mode

In pulse-skip mode (SKIP = high), the error amplifier disables switching of the power stages when it detects an output higher than 5 V. The oscillator halts. The IC then skips switching cycles until the output voltage drops below 5 V. Then the error amplifier reactivates the oscillator and switching of the power stages starts again. The pulse-skip regulation mode minimizes operating current because it does not switch continuously and deactivates all functions except bandgap reference and error amplifier when the output is higher than 5 V. When switching is disabled from the error amplifier, the load is also isolated from the input. SKIP is a logic input and should not remain floating. The typical operating circuit of the TPS60110 in pulse skip mode is shown in Figure 1.

constant-frequency mode

When SKIP is low, the charge pump runs continuously at the frequency f_{OSC} . The control circuit, fed from the error amplifier, controls the charge on C_{1F} and C_{2F} by driving the gates of the FETs T_{12}/T_{13} and T_{22}/T_{23} , respectively. When the output voltage falls, the gate drive increases, resulting in a larger voltage across C_{1F} and C_{2F} . This regulation scheme minimizes output ripple. Since the device switches continuously, the output noise contains well-defined frequency components, and the circuit requires smaller external capacitors for a given output ripple. However, constant-frequency mode, due to higher operating current, is less efficient at light loads than pulse-skip mode.

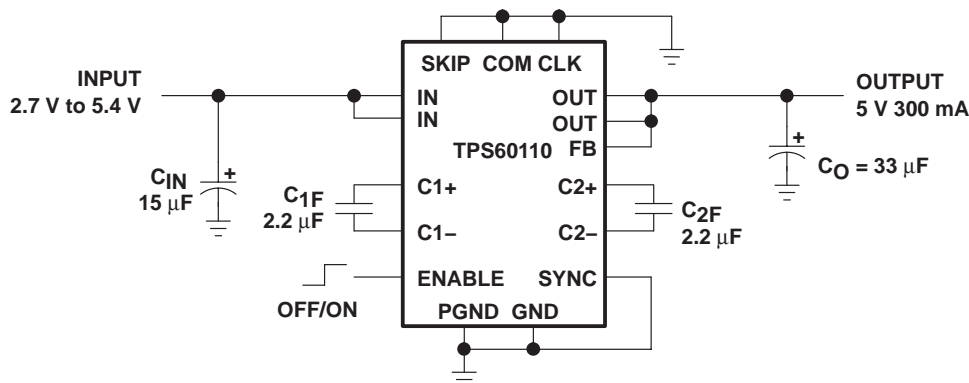

Figure 24. Typical Operating Circuit TPS60110 in Constant Frequency Mode

Table 1. Tradeoffs Between Operating Modes

FEATURE	PULSE-SKIP MODE (SKIP = High)	CONSTANT-FREQUENCY MODE (SKIP = Low)
Best light-load efficiency	X	
Smallest external component size for a given output ripple		X
Output ripple amplitude	Small amplitude	Very small amplitude
Output ripple frequency	Variable	Constant
Load regulation	Very good	Good

NOTE: Even in pulse-skip mode the output ripple amplitude is small if the push-pull operating mode is selected via COM.

TPS60110 REGULATED 5-V 300-mA LOW-NOISE CHARGE PUMP DC/DC CONVERTER

SLVS215C – JUNE 1999 – REVISED AUGUST 2008

detailed description (continued)

push-pull operating mode

In push-pull operating mode (COM = low), the two single-ended charge pumps operate with 180° phase shift. The oscillator signal has a 50% duty cycle. Each single-ended charge pump transfers charge into its transfer capacitor (C_{XF}) in one-half of the period. During the other half of the period (transfer phase), C_{XF} is placed in series with the input to transfer its charge to C_O . While one single-ended charge pump is in the charge phase, the other one is in the transfer phase. This operation specifies an almost constant output current which ensures a low output ripple. COM is a logic input and should not remain floating. The typical operating circuit of the TPS60110 in push-pull mode is shown in Figure 1 and Figure 24.

single-ended operating mode

When COM is high, the device runs in single-ended operating mode. The two single-ended charge pumps operate in parallel without phase shift. They transfer charge into the transfer capacitor (C_F) in one half of the period. During the other half of the period (transfer phase), C_F is placed in series with the input to transfer its charge to C_O . In single-ended operating mode only one transfer capacitor ($C_F = C_{1F} + C_{2F}$) is required, resulting in less board space.

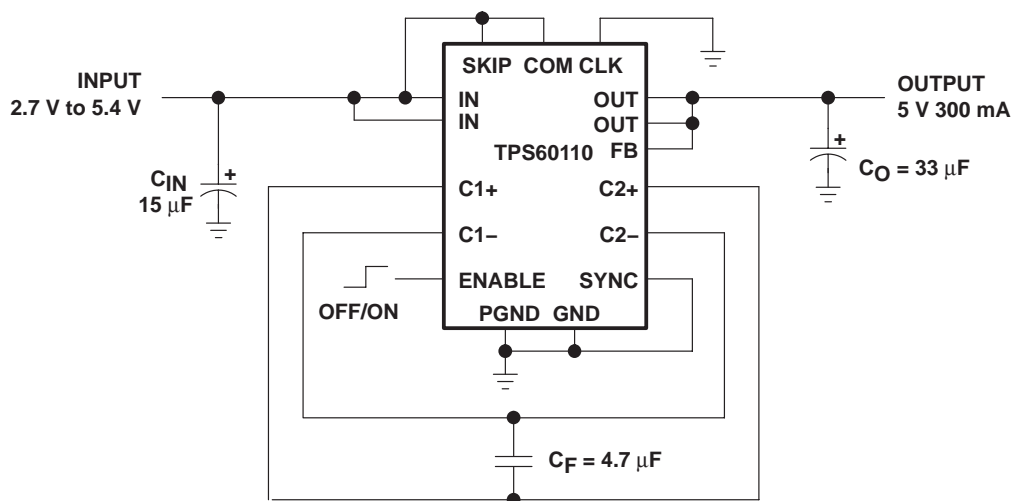

Figure 25. Typical Operating Circuit TPS60110 in Single-Ended Operating Mode

Table 2. Tradeoffs Between Operating Modes

FEATURE	PUSH-PULL MODE (COM = Low)	SINGLE-ENDED MODE (COM = High)
Output ripple amplitude	Small amplitude	Large amplitude
Smallest board space		X

detailed description (continued)

shutdown

Driving ENABLE low places the device in shutdown mode. This disables all switches, the oscillator, and control logic. The device typically draws 0.05- μ A (1- μ A max) of supply current in this mode. Leakage current drawn from the output is as low as 1 μ A max. The device exits shutdown once ENABLE is high. The typical no-load shutdown exit time is 20 μ s. When the device is in shutdown, the load is isolated from the input and the output is high impedance.

external clock signal

If the device operates at a user defined frequency, an external clock signal can be used. Therefore, SYNC needs to be connected to IN and the external oscillator signal can drive CLK. The maximum external frequency is limited to 800 kHz. The switching frequency of the converter is half of the external oscillator frequency. It is recommended to operate the charge pump in constant-frequency mode if an external clock signal is used so that the output noise contains only well-defined frequency components.

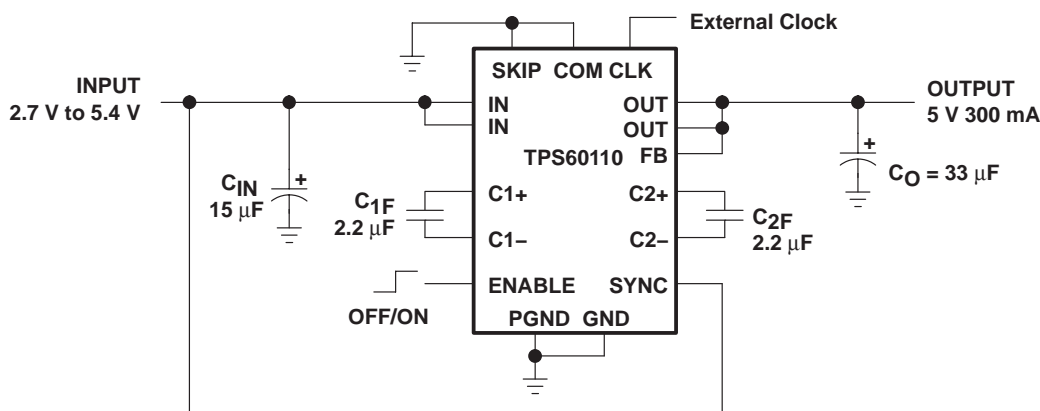

Figure 26. Typical Operating Circuit TPS60110 With External Synchronization

TPS60110
REGULATED 5-V 300-mA LOW-NOISE
CHARGE PUMP DC/DC CONVERTER

SLVS215C – JUNE 1999 – REVISED AUGUST 2008

APPLICATION INFORMATION

capacitor selection

The TPS60110 requires only four external capacitors as shown in the basic application circuit. Their values are closely linked to the output current capacity, output noise requirements, and mode of operation. Generally, the transfer capacitors (C_{XF}) is the smallest.

The input capacitor improves system efficiency by reducing the input impedance and stabilizes the input current. C_{IN} is recommended to be about two to four times as large as C_{XF} .

The output capacitor (C_O) can be selected from 8-times to 50-times larger than C_{XF} , depending on the mode of operation and ripple tolerance†. Tables 3 and 4 show capacitor values recommended for low quiescent-current operation (pulse-skip mode) and for low output voltage ripple operation (constant-frequency mode). A recommendation is given for smallest size.

Table 3. Recommended Capacitor Values for Low Quiescent-Current Operation† (pulse-skip mode)

V_{IN} [V]	I_O [mA]	C_{IN} [μ F]		C_{XF} [μ F]	C_O [μ F]		OUTPUT VOLTAGE RIPPLE V_{PP} [mV]
		TANTALUM	CERAMIC		TANTALUM	CERAMIC	
3.6	225	15		2.2	33		145
3.6	225		4.7 + 10, (X5R)	2.2		22 + 10, (X5R)	55
3.6	300	15		2.2	33		135
3.6	300		4.7 + 10, (X5R)	2.2		22 + 10, (X5R)	75

† All measurements are done with additional 1- μ F X7R ceramic capacitors at input and output.

Table 4. Recommended Capacitor Values for Low Output Voltage Ripple Operation† (constant-frequency mode)

V_{IN} [V]	I_O [mA]	C_{IN} [μ F]		C_{XF} [μ F]	C_O [μ F]		OUTPUT VOLTAGE RIPPLE V_{PP} [mV]
		TANTALUM	CERAMIC		TANTALUM	CERAMIC	
3.6	225	15		2.2	33		17
3.6	225		4.7 + 10, (X5R)	2.2		22 + 10, (X5R)	6
3.6	300	15		2.2	33		22
3.6	300		4.7 + 10, (X5R)	2.2		22 + 10, (X5R)	8

† All measurements are done with additional 1- μ F X7R ceramic capacitors at input and output.

† In constant-frequency mode always select $C_O \geq 33 \mu$ F



APPLICATION INFORMATION

For the TPS60110, the smallest board space size can be achieved using Sprague's 595D-series tantalum capacitors for input and output. However, with the trend towards high capacitance ceramic capacitors in smaller size packages, these type of capacitors might soon become competitive in size.

Table 5. Recommended Capacitors

MANUFACTURER	PART NUMBER	CAPACITANCE	TYPE
Taiyo Yuden	LMK212BJ105KG-T	1 µF	Ceramic
	LMK212BJ225MG-T	2.2 µF	Ceramic
	LMK316BJ475KL-T	4.7 µF	Ceramic
	JMK316BJ106ML-T	10 µF	Ceramic
	LMK432BJ226MM-T	22 µF	Ceramic
AVX	0805ZC105KAT2A	1 µF	Ceramic
	1206ZC225KAT2A	2.2 µF	Ceramic
	TPSC156K020R0450	15 µF	Tantalum
	TPSC336K010R0375	33 µF	Tantalum
Sprague	595D156X06R3A2T	15 µF	Tantalum
	595D156X0016B2T	15 µF	Tantalum
	595D336X06R3A2T	33 µF	Tantalum
	595D336X0016B2T	33 µF	Tantalum
	595D336X0016C2T	33 µF	Tantalum
Kemet	T494C156K010AS	15 µF	Tantalum
	T494C336K010AS	33 µF	Tantalum

Table 6 lists the manufacturers of recommended capacitors. In most applications surface-mount tantalum capacitors will be the right choice. However, ceramic capacitors provides the lowest output voltage ripple due to their typically lower ESR.

Table 6. Recommended Capacitor Manufacturers

MANUFACTURER	CAPACITOR TYPE	INTERNET
Taiyo Yuden	X7R/X5R ceramic	www.t-yuden.com
AVX	X7R/X5R ceramic TPS-series tantalum	www.avxcorp.com
Sprague	595D-series tantalum 593D-series tantalum	www.vishay.com
Kemet	T494-series tantalum	www.kemet.com

power dissipation

The power dissipated in the TPS60110 depends on output current and is approximated by:

$$P_{DISS} = I_O \times (2 V_{IN} - V_O) \text{ for } I_Q \ll I_O$$

P_{DISS} must be less than that allowed by the package rating. See the ratings for 20-PowerPAD™ package power-dissipation limits and deratings.

TPS60110 REGULATED 5-V 300-mA LOW-NOISE CHARGE PUMP DC/DC CONVERTER

SLVS215C – JUNE 1999 – REVISED AUGUST 2008

APPLICATION INFORMATION

layout

All capacitors should be soldered in close proximity to the IC. A PCB layout proposal for a two-layer board is given in Figure 27. Care has been taken to connect both single-ended charge pumps symmetrically to the load to achieve optimized output voltage ripple performance. The proposed layout also provides improved thermal performance as the exposed leadframe is soldered to the PCB. The bottom layer of the PCB is a ground plane only. All ground areas on the PCB should be connected. Connect ground areas on top layer to the bottom layer via through hole connections.

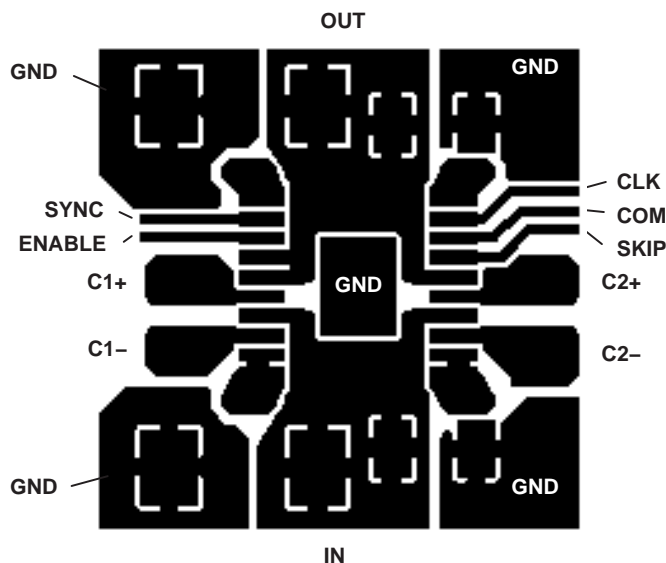

Figure 27. Recommended PCB Layout for TPS60110 (top view)

An evaluation module for the TPS60110 is available and can be ordered under literature code SLVP132 or under product code TPS60110EVM-132.

APPLICATION INFORMATION

applications proposals

paralleling of two TPS60110 to deliver 600 mA

The TPS60110 can be paralleled to yield higher load currents. The circuit of Figure 28 can deliver 600 mA at an output voltage of 5 V. It uses two TPS60110 devices in parallel. The devices can share the output capacitors, but each one requires its own transfer capacitors and input capacitor. For best performance, the paralleled devices should operate in the same mode (pulse-skip or constant frequency).

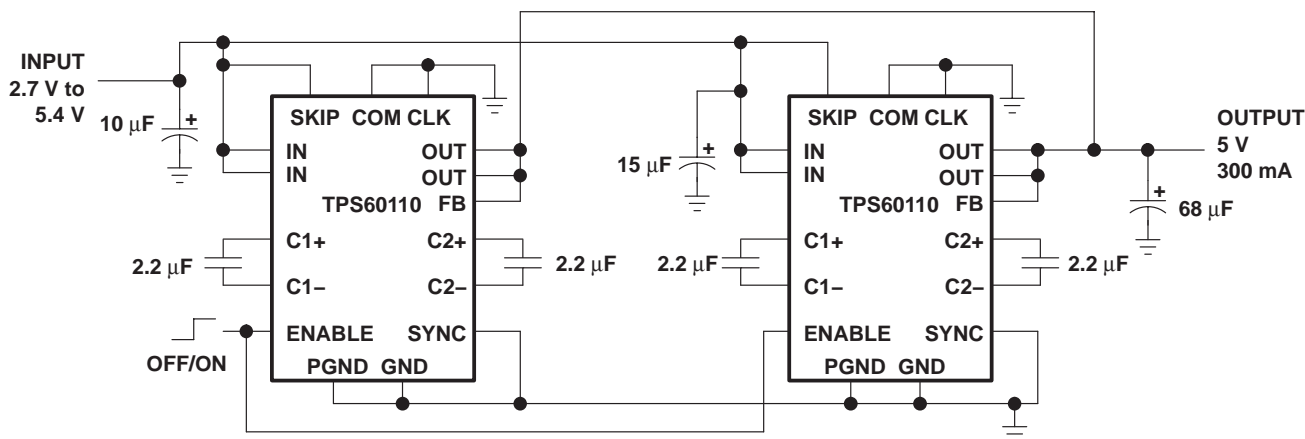

Figure 28. Paralleling of Two TPS60110

TPS60110 with LC output filter for ultra low ripple

For applications where extremely low output ripple is required, a small LC filter is recommended. This is shown in Figure 29. The addition of a small inductor and filter capacitor will reduce the output ripple well below what could be achieved with capacitors alone. The corner frequency of 500 kHz was chosen above the 300 kHz switching frequency to avoid loop stability issues in case the feedback is taken from the output of the LC filter. Leaving the feedback (FB) connection point before the LC filter, the filter capacitance value can be increased to achieve even higher ripple attenuation without affecting stability margin.

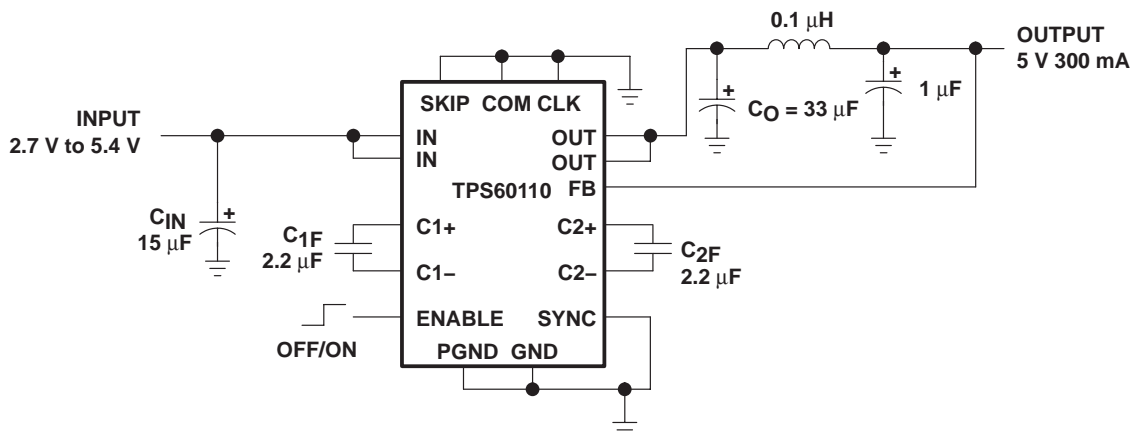

Figure 29. TPS60110 With LC Filter for Ultra Low Output Ripple Applications

TPS60110 REGULATED 5-V 300-mA LOW-NOISE CHARGE PUMP DC/DC CONVERTER

SLVS215C – JUNE 1999 – REVISED AUGUST 2008

APPLICATION INFORMATION

related information

application reports

For more application information see:

- *PowerPAD™ Application Report* (Literature Number: SLMA002)
- *TPS6010x/TPS6011x Charge Pump Application Report* (Literature Number: SLVA070)

device family products

Other devices in this family are:

PART NUMBER	LITERATURE NUMBER	DESCRIPTION
TPS60100	SLVS213	Regulated 3.3-V, 200-mA Low-Noise Charge Pump DC/DC Converter
TPS60101	SLVS214	Regulated 3.3-V, 100-mA Low-Noise Charge Pump DC/DC Converter
TPS60111	SLVS216	Regulated 5-V, 150-mA Low-Noise Charge Pump DC/DC Converter

PACKAGING INFORMATION

Orderable Device	Status (1)	Package Type	Package Drawing	Pins	Package Qty	Eco Plan (2)	Lead/Ball Finish	MSL Peak Temp (3)	Op Temp (°C)	Top-Side Markings (4)	Samples
TPS60110PWP	ACTIVE	HTSSOP	PWP	20	70	Green (RoHS & no Sb/Br)	CU NIPDAU	Level-2-260C-1 YEAR	-40 to 85	TPS60110	Samples
TPS60110PWPG4	ACTIVE	HTSSOP	PWP	20	70	Green (RoHS & no Sb/Br)	CU NIPDAU	Level-2-260C-1 YEAR	-40 to 85	TPS60110	Samples
TPS60110PWPR	ACTIVE	HTSSOP	PWP	20	2000	Green (RoHS & no Sb/Br)	CU NIPDAU	Level-2-260C-1 YEAR	-40 to 85	TPS60110	Samples
TPS60110PWPRG4	ACTIVE	HTSSOP	PWP	20	2000	Green (RoHS & no Sb/Br)	CU NIPDAU	Level-2-260C-1 YEAR	-40 to 85	TPS60110	Samples

(1) The marketing status values are defined as follows:

ACTIVE: Product device recommended for new designs.

LIFEBUY: TI has announced that the device will be discontinued, and a lifetime-buy period is in effect.

NRND: Not recommended for new designs. Device is in production to support existing customers, but TI does not recommend using this part in a new design.

PREVIEW: Device has been announced but is not in production. Samples may or may not be available.

OBSOLETE: TI has discontinued the production of the device.

(2) Eco Plan - The planned eco-friendly classification: Pb-Free (RoHS), Pb-Free (RoHS Exempt), or Green (RoHS & no Sb/Br) - please check <http://www.ti.com/productcontent> for the latest availability information and additional product content details.

TBD: The Pb-Free/Green conversion plan has not been defined.

Pb-Free (RoHS): TI's terms "Lead-Free" or "Pb-Free" mean semiconductor products that are compatible with the current RoHS requirements for all 6 substances, including the requirement that lead not exceed 0.1% by weight in homogeneous materials. Where designed to be soldered at high temperatures, TI Pb-Free products are suitable for use in specified lead-free processes.

Pb-Free (RoHS Exempt): This component has a RoHS exemption for either 1) lead-based flip-chip solder bumps used between the die and package, or 2) lead-based die adhesive used between the die and leadframe. The component is otherwise considered Pb-Free (RoHS compatible) as defined above.

Green (RoHS & no Sb/Br): TI defines "Green" to mean Pb-Free (RoHS compatible), and free of Bromine (Br) and Antimony (Sb) based flame retardants (Br or Sb do not exceed 0.1% by weight in homogeneous material)

(3) MSL, Peak Temp. -- The Moisture Sensitivity Level rating according to the JEDEC industry standard classifications, and peak solder temperature.

(4) Multiple Top-Side Markings will be inside parentheses. Only one Top-Side Marking contained in parentheses and separated by a "~" will appear on a device. If a line is indented then it is a continuation of the previous line and the two combined represent the entire Top-Side Marking for that device.

Important Information and Disclaimer: The information provided on this page represents TI's knowledge and belief as of the date that it is provided. TI bases its knowledge and belief on information provided by third parties, and makes no representation or warranty as to the accuracy of such information. Efforts are underway to better integrate information from third parties. TI has taken and continues to take reasonable steps to provide representative and accurate information but may not have conducted destructive testing or chemical analysis on incoming materials and chemicals. TI and TI suppliers consider certain information to be proprietary, and thus CAS numbers and other limited information may not be available for release.

In no event shall TI's liability arising out of such information exceed the total purchase price of the TI part(s) at issue in this document sold by TI to Customer on an annual basis.

TAPE AND REEL INFORMATION

QUADRANT ASSIGNMENTS FOR PIN 1 ORIENTATION IN TAPE

*All dimensions are nominal

Device	Package Type	Package Drawing	Pins	SPQ	Reel Diameter (mm)	Reel Width W1 (mm)	A0 (mm)	B0 (mm)	K0 (mm)	P1 (mm)	W (mm)	Pin1 Quadrant
TPS60110PWPR	HTSSOP	PWP	20	2000	330.0	16.4	6.95	7.1	1.6	8.0	16.0	Q1

TAPE AND REEL BOX DIMENSIONS

*All dimensions are nominal

Device	Package Type	Package Drawing	Pins	SPQ	Length (mm)	Width (mm)	Height (mm)
TPS60110PWPR	HTSSOP	PWP	20	2000	350.0	350.0	43.0

MECHANICAL DATA

PWP (R-PDSO-G20)

PowerPAD™ PLASTIC SMALL OUTLINE



4073225-4/1 05/11

- NOTES:
- All linear dimensions are in millimeters.
 - This drawing is subject to change without notice.
 - Body dimensions do not include mold flash or protrusions. Mold flash and protrusion shall not exceed 0.15 per side.
 - This package is designed to be soldered to a thermal pad on the board. Refer to Technical Brief, PowerPad Thermally Enhanced Package, Texas Instruments Literature No. SLMA002 for information regarding recommended board layout. This document is available at www.ti.com <<http://www.ti.com>>.
 - See the additional figure in the Product Data Sheet for details regarding the exposed thermal pad features and dimensions.
 - Falls within JEDEC MO-153

PowerPAD is a trademark of Texas Instruments.

PWP (R-PDSO-G20) PowerPAD™ SMALL PLASTIC OUTLINE

THERMAL INFORMATION

This PowerPAD™ package incorporates an exposed thermal pad that is designed to be attached to a printed circuit board (PCB). The thermal pad must be soldered directly to the PCB. After soldering, the PCB can be used as a heatsink. In addition, through the use of thermal vias, the thermal pad can be attached directly to the appropriate copper plane shown in the electrical schematic for the device, or alternatively, can be attached to a special heatsink structure designed into the PCB. This design optimizes the heat transfer from the integrated circuit (IC).

For additional information on the PowerPAD package and how to take advantage of its heat dissipating abilities, refer to Technical Brief, PowerPAD Thermally Enhanced Package, Texas Instruments Literature No. SLMA002 and Application Brief, PowerPAD Made Easy, Texas Instruments Literature No. SLMA004. Both documents are available at www.ti.com.

The exposed thermal pad dimensions for this package are shown in the following illustration.

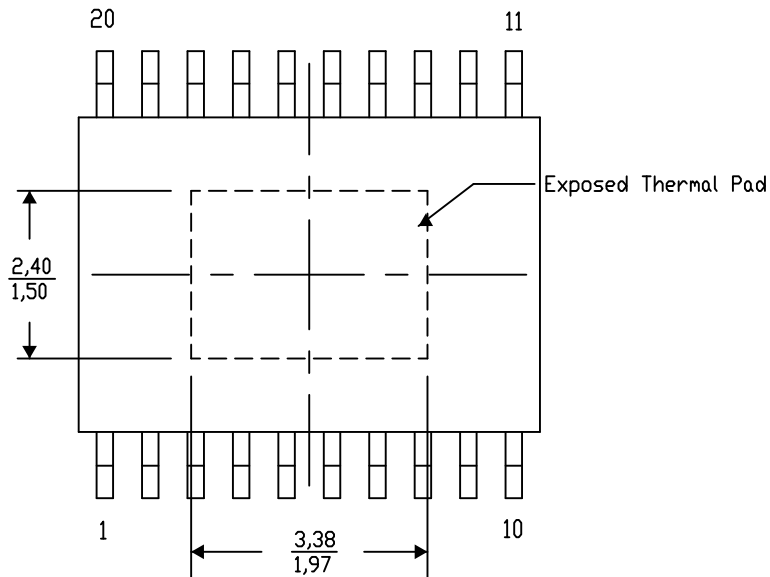

Top View

Exposed Thermal Pad Dimensions

4206332-19/AO 01/16

NOTE: A. All linear dimensions are in millimeters

PowerPAD is a trademark of Texas Instruments

PWP (R-PDSO-G20)

PowerPAD™ PLASTIC SMALL OUTLINE

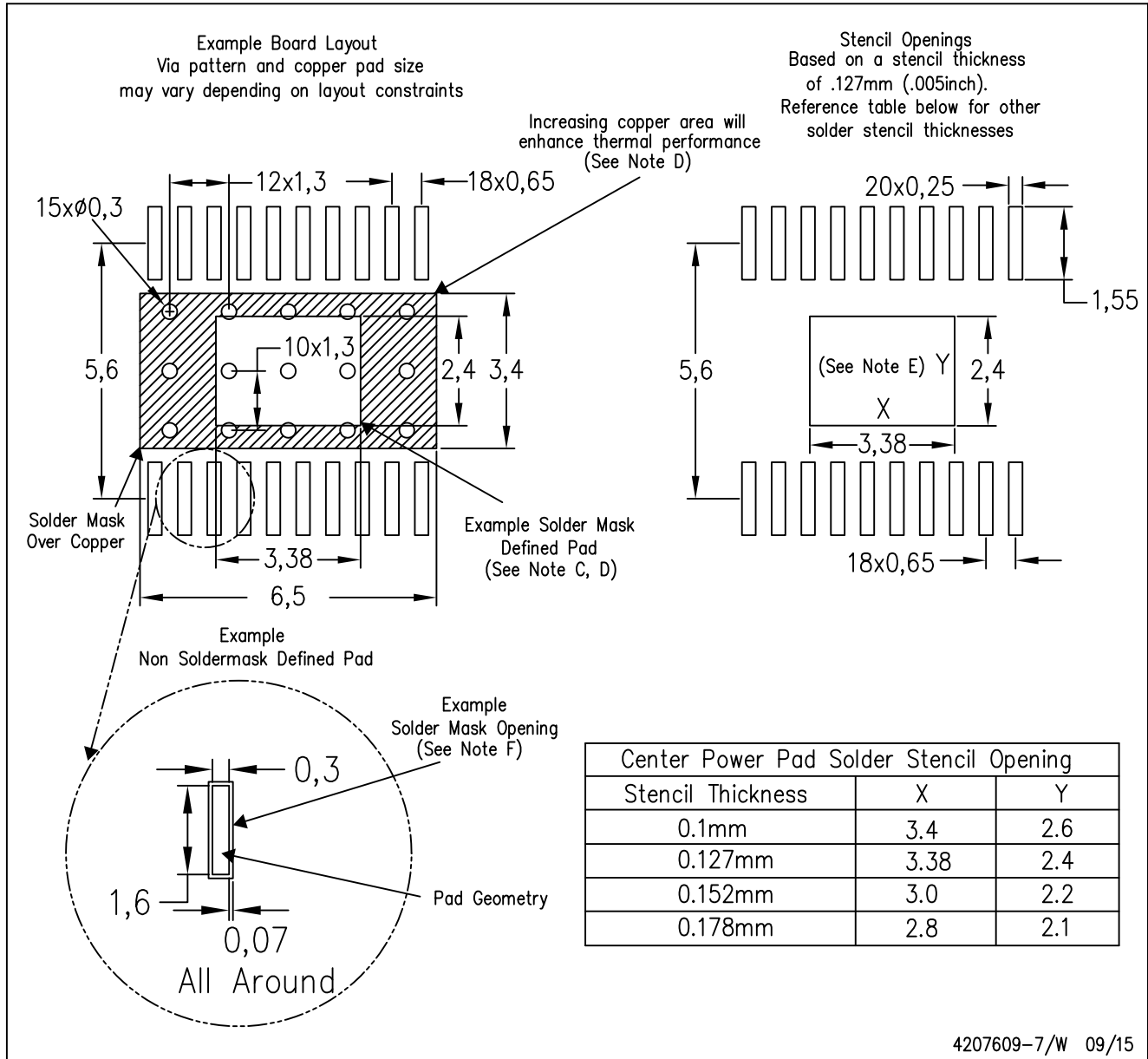

- NOTES:
- A. All linear dimensions are in millimeters.
 - B. This drawing is subject to change without notice.
 - C. Customers should place a note on the circuit board fabrication drawing not to alter the center solder mask defined pad.
 - D. This package is designed to be soldered to a thermal pad on the board. Refer to Technical Brief, PowerPad Thermally Enhanced Package, Texas Instruments Literature No. SLMA002, SLMA004, and also the Product Data Sheets for specific thermal information, via requirements, and recommended board layout. These documents are available at www.ti.com <<http://www.ti.com>>. Publication IPC-7351 is recommended for alternate designs.
 - E. Laser cutting apertures with trapezoidal walls and also rounding corners will offer better paste release. Customers should contact their board assembly site for stencil design recommendations. Example stencil design based on a 50% volumetric metal load solder paste. Refer to IPC-7525 for other stencil recommendations.
 - F. Customers should contact their board fabrication site for solder mask tolerances between and around signal pads.

IMPORTANT NOTICE AND DISCLAIMER

TI PROVIDES TECHNICAL AND RELIABILITY DATA (INCLUDING DATASHEETS), DESIGN RESOURCES (INCLUDING REFERENCE DESIGNS), APPLICATION OR OTHER DESIGN ADVICE, WEB TOOLS, SAFETY INFORMATION, AND OTHER RESOURCES "AS IS" AND WITH ALL FAULTS, AND DISCLAIMS ALL WARRANTIES, EXPRESS AND IMPLIED, INCLUDING WITHOUT LIMITATION ANY IMPLIED WARRANTIES OF MERCHANTABILITY, FITNESS FOR A PARTICULAR PURPOSE OR NON-INFRINGEMENT OF THIRD PARTY INTELLECTUAL PROPERTY RIGHTS.

These resources are intended for skilled developers designing with TI products. You are solely responsible for (1) selecting the appropriate TI products for your application, (2) designing, validating and testing your application, and (3) ensuring your application meets applicable standards, and any other safety, security, or other requirements. These resources are subject to change without notice. TI grants you permission to use these resources only for development of an application that uses the TI products described in the resource. Other reproduction and display of these resources is prohibited. No license is granted to any other TI intellectual property right or to any third party intellectual property right. TI disclaims responsibility for, and you will fully indemnify TI and its representatives against, any claims, damages, costs, losses, and liabilities arising out of your use of these resources.

TI's products are provided subject to TI's Terms of Sale (www.ti.com/legal/termsofsale.html) or other applicable terms available either on ti.com or provided in conjunction with such TI products. TI's provision of these resources does not expand or otherwise alter TI's applicable warranties or warranty disclaimers for TI products.

Mailing Address: Texas Instruments, Post Office Box 655303, Dallas, Texas 75265
Copyright © 2019, Texas Instruments Incorporated

Looking for pricing, stock, or lifecycle information?

Click below to explore more details on WIN SOURCE:

 [View TPS60110PWP](#) on WIN SOURCE

 [Texas Instruments](#) Information

Optimize Your Supply Chain with WIN SOURCE Solutions

-  Global Sourcing Solution
-  Obsolete Management
-  Cost Control Management
-  Shortage Management
-  Alternative Solution
-  Excess Inventory Management