



**THE DATASHEET OF  
TPS60402DBVR**



## TPS6040x Unregulated 60-mA Charge Pump Voltage Inverter

### 1 Features

- Inverts Input Supply Voltage
- Up to 60-mA Output Current
- Only Three Small 1- $\mu$ F Ceramic Capacitors Needed
- Input Voltage Range From 1.6 V to 5.5 V
- PowerSave-Mode for Improved Efficiency at Low-Output Currents (TPS60400)
- Device Quiescent Current Typical 65  $\mu$ A
- Integrated Active Schottky-Diode for Start-up Into Load
- Small 5-Pin SOT-23 Package
- Evaluation Module Available TPS60400EVM-178

### 2 Applications

- LCD Bias
- GaAs Bias for RF Power Amps
- Sensor Supply in Portable Instruments
- Bipolar Amplifier Supply
- Medical Instruments
- Battery-Operated Equipment

### 3 Description

The TPS6040x family of devices generates an unregulated negative output voltage from an input voltage ranging from 1.6 V to 5.5 V. The devices are typically supplied by a preregulated supply rail of 5 V or 3.3 V. Due to its wide input voltage range, two or three NiCd, NiMH, or alkaline battery cells, as well as one Li-Ion cell can also power them.

Only three external 1- $\mu$ F capacitors are required to build a complete DC-DC charge pump inverter. Assembled in a 5-pin SOT-23 package, the complete converter can be built on a 50-mm<sup>2</sup> board area. Additional board area and component count reduction is achieved by replacing the Schottky diode that is typically needed for start-up into load by integrated circuitry.

The TPS6040x can deliver a maximum output current of 60 mA with a typical conversion efficiency of greater than 90% over a wide output current range. Three device options with 20-kHz, 50-kHz, and 250-kHz fixed-frequency operation are available. TPS60400 comes with a variable switching frequency to reduce operating current in applications with a wide load range and enables the design with low-value capacitors.

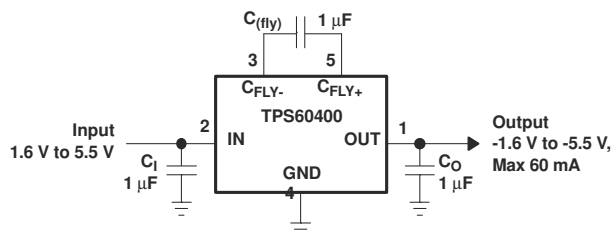

**Typical Application**

### Device Information

PART NUMBER	PACKAGE (1)	BODY SIZE (NOM)
TPS6040x	SOT-23 (5)	2.90 mm x 1.60 mm

- (1) For all available packages, see the orderable addendum at the end of the datasheet.

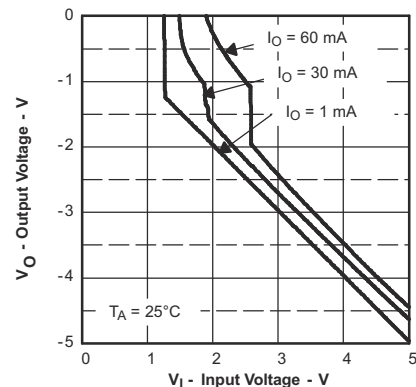

**Output Voltage vs Input Voltage**



## Table of Contents

<b>1 Features</b> .....	1	8.4 Device Functional Modes.....	12
<b>2 Applications</b> .....	1	<b>9 Application and Implementation</b> .....	13
<b>3 Description</b> .....	1	9.1 Application Information.....	13
<b>4 Revision History</b> .....	2	9.2 Typical Application.....	13
<b>5 Device Comparison Table</b> .....	3	9.3 System Examples.....	16
<b>6 Pin Configuration and Functions</b> .....	3	<b>10 Power Supply Recommendations</b> .....	20
<b>7 Specifications</b> .....	4	<b>11 Layout</b> .....	21
7.1 Absolute Maximum Ratings.....	4	11.1 Layout Guidelines.....	21
7.2 Handling Ratings.....	4	11.2 Layout Example.....	21
7.3 Recommended Operating Conditions.....	4	<b>12 Device and Documentation Support</b> .....	22
7.4 Thermal Information.....	4	12.1 Device Support.....	22
7.5 Electrical Characteristics.....	5	12.2 Related Links.....	22
7.6 Typical Characteristics.....	5	12.3 Trademarks.....	22
<b>8 Detailed Description</b> .....	10	12.4 Electrostatic Discharge Caution.....	22
8.1 Overview.....	10	12.5 Glossary.....	22
8.2 Functional Block Diagram.....	10	<b>13 Mechanical, Packaging, and Orderable Information</b> .....	22
8.3 Feature Description.....	11		

## 4 Revision History

NOTE: Page numbers for previous revisions may differ from page numbers in the current version.

### Changes from Revision B (April 2015) to Revision C (October 2020) Page

- Updated the numbering format for tables, figures and cross-references throughout the document..... 1

### Changes from Revision A (November 2004) to Revision B (April 2015) Page

- Added *Handling Rating* table, *Feature Description* section, *Device Functional Modes*, *Application and Implementation* section, *Power Supply Recommendations* section, *Layout* section, *Device and Documentation Support* section, and *Mechanical, Packaging, and Orderable Information* section..... 1

## 5 Device Comparison Table

PART NUMBER <sup>(1)</sup>	MARKING DBV PACKAGE	TYPICAL FLYING CAPACITOR [μF]	FEATURE
TPS60400DBV	PFKI	1	Variable switching frequency 50 kHz-250 kHz
TPS60401DBV	PFLI	10	Fixed frequency 20 kHz
TPS60402DBV	PFMI	3.3	Fixed frequency 50 kHz
TPS60403DBV	PFNI	1	Fixed frequency 250 kHz

(1) The DBV package is available taped and reeled. Add R suffix to device type (for example, TPS60400DBVR) to order quantities of 3000 devices per reel. Add T suffix to device type (for example, TPS60400DBVT) to order quantities of 250 devices per reel.

## 6 Pin Configuration and Functions

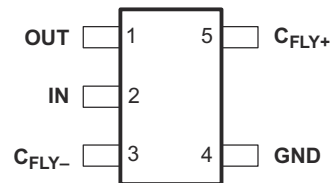

**Figure 6-1. DBV Package 5 Pins Top View**

**Table 6-1. Pin Functions**

PIN		I/O	DESCRIPTION
NAME	NO.		
C <sub>FLY+</sub>	5		Positive terminal of the flying capacitor C <sub>(fly)</sub>
C <sub>FLY-</sub>	3		Negative terminal of the flying capacitor C <sub>(fly)</sub>
GND	4		Ground
IN	2	I	Supply input. Connect to an input supply in the 1.6-V to 5.5-V range. Bypass IN to GND with a capacitor that has the same value as the flying capacitor.
OUT	1	O	Power output with V <sub>O</sub> = -V <sub>I</sub> Bypass OUT to GND with the output filter capacitor C <sub>O</sub> .

## 7 Specifications

### 7.1 Absolute Maximum Ratings

over operating free-air temperature range (unless otherwise noted)<sup>(1)</sup>

		MIN	MAX	UNIT
Voltage range	IN to GND	-0.3	5.5	V
	OUT to GND	-5.5	0.3	V
	C <sub>FLY-</sub> to GND	0.3	V <sub>O</sub> - 0.3	V
	C <sub>FLY+</sub> to GND	-0.3 V	V <sub>I</sub> + 0.3	V
Continuous power dissipation		See <a href="#">Section 9.2.1.2.5</a>		
Continuous output current			80	mA
Maximum junction temperature, T <sub>J</sub>			150	°C

- (1) Stresses beyond those listed under *Absolute Maximum Ratings* may cause permanent damage to the device. These are stress ratings only, and functional operation of the device at these or any other conditions beyond those indicated under *Recommended Operating Conditions* is not implied. Exposure to absolute-maximum-rated conditions for extended periods may affect device reliability.

### 7.2 Handling Ratings

		MIN	MAX	UNIT	
T <sub>stg</sub>	Storage temperature range	-55°C	150°C	°C	
V <sub>(ESD)</sub>	Electrostatic discharge	Human body model (HBM), per ANSI/ESDA/JEDEC JS-001, all pins <sup>(1)</sup>	-1000	1000	V
		Charged device model (CDM), per JEDEC specification JESD22-C101, all pins <sup>(2)</sup>	-500	500	

- (1) JEDEC document JEP155 states that 500-V HBM allows safe manufacturing with a standard ESD control process.  
 (2) JEDEC document JEP157 states that 250-V CDM allows safe manufacturing with a standard ESD control process.

### 7.3 Recommended Operating Conditions

		MIN	NOM	MAX	UNIT
Input voltage range, V <sub>I</sub>		1.8		5.25	V
Output current range at OUT, I <sub>O</sub>				60	mA
Input capacitor, C <sub>I</sub>		0	C <sub>(fly)</sub>		μF
Flying capacitor, C <sub>(fly)</sub>			1		μF
Output capacitor, C <sub>O</sub>			1	100	μF
Operating junction temperature, T <sub>J</sub>		-40		125	°C

### 7.4 Thermal Information

THERMAL METRIC <sup>(1)</sup>		TPS6040x	UNIT
		DBV	
		5 PINS	
R <sub>θJA</sub>	Junction-to-ambient thermal resistance	221.2	°C/W
R <sub>θJC(top)</sub>	Junction-to-case (top) thermal resistance	81.9	
R <sub>θJB</sub>	Junction-to-board thermal resistance	39.8	
Ψ <sub>JT</sub>	Junction-to-top characterization parameter	3.3	
Ψ <sub>JB</sub>	Junction-to-board characterization parameter	38.9	
R <sub>θJC(bot)</sub>	Junction-to-case (bottom) thermal resistance	n/a	

- (1) For more information about traditional and new thermal metrics, see the *IC Package Thermal Metrics* application report, [SPRA953](#).

## 7.5 Electrical Characteristics

$C_I = C_{(fly)} = C_O$  (according to Table 1),  $T_C = -40^\circ\text{C}$  to  $85^\circ\text{C}$ ,  $V_I = 5\text{ V}$  over recommended operating free-air temperature range (unless otherwise noted)

PARAMETER		TEST CONDITIONS		MIN	TYP	MAX	UNIT		
$V_I$	Supply voltage range	At $T_C = -40^\circ\text{C}$ to $85^\circ\text{C}$ , $R_L = 5\text{ k}\Omega$		1.8		5.25	V		
		At $T_C \geq 0^\circ\text{C}$ , $R_L = 5\text{ k}\Omega$		1.6					
$I_O$	Maximum output current at $V_O$			60			mA		
$V_O$	Output voltage				$-V_I$		V		
$V_{P-P}$	Output voltage ripple	TPS60400	$I_O = 5\text{ mA}$	$C_{(fly)} = 1\text{ }\mu\text{F}$ , $C_O = 2.2\text{ }\mu\text{F}$		35	mV <sub>P-P</sub>		
		TPS60401			$C_{(fly)} = C_O = 10\text{ }\mu\text{F}$			20	
		TPS60402			$C_{(fly)} = C_O = 3.3\text{ }\mu\text{F}$			20	
		TPS60403			$C_{(fly)} = C_O = 1\text{ }\mu\text{F}$			15	
$I_Q$	Quiescent current (no-load input current)	TPS60400	At $V_I = 5\text{ V}$			125	270	$\mu\text{A}$	
		TPS60401				65	190		
		TPS60402				120	270		
		TPS60403				425	700		
		TPS60400	At $T \leq 60^\circ\text{C}$ , $V_I = 5\text{ V}$				210	$\mu\text{A}$	
		TPS60401					135		
		TPS60402					210		
		TPS60403					640		
$f_{OSC}$	Internal switching frequency	TPS60400	VCO version			30	50-250	350	kHz
		TPS60401				13	20	28	
		TPS60402				30	50	70	
		TPS60403				150	250	300	
	Impedance at $25^\circ\text{C}$ , $V_I = 5\text{ V}$	TPS60400	$C_I = C_{(fly)} = C_O = 1\text{ }\mu\text{F}$			12	15	$\Omega$	
		TPS60401			$C_I = C_{(fly)} = C_O = 10\text{ }\mu\text{F}$		12		15
		TPS60402			$C_I = C_{(fly)} = C_O = 3.3\text{ }\mu\text{F}$		12		15
		TPS60403			$C_I = C_{(fly)} = C_O = 1\text{ }\mu\text{F}$		12		15

## 7.6 Typical Characteristics

**Table 7-1. Table of Graphs**

			FIGURE
$\eta$	Efficiency	vs Output current at 3.3 V, 5 V TPS60400, TPS60401, TPS60402, TPS60403	Figure 7-1, Figure 7-2
$I_I$	Input current	vs Output current TPS60400, TPS60401, TPS60402, TPS60403	Figure 7-3, Figure 7-4
$I_S$	Supply current	vs Input voltage TPS60400, TPS60401, TPS60402, TPS60403	Figure 7-5, Figure 7-6
	Output resistance	vs Input voltage at $-40^\circ\text{C}$ , $0^\circ\text{C}$ , $25^\circ\text{C}$ , $85^\circ\text{C}$ TPS60400, $C_I = C_{(fly)} = C_O = 1\text{ }\mu\text{F}$ TPS60401, $C_I = C_{(fly)} = C_O = 10\text{ }\mu\text{F}$ TPS60402, $C_I = C_{(fly)} = C_O = 3.3\text{ }\mu\text{F}$ TPS60403, $C_I = C_{(fly)} = C_O = 1\text{ }\mu\text{F}$	Figure 7-7, Figure 7-8, Figure 7-9, Figure 7-10
$V_O$	Output voltage	vs Output current at $25^\circ\text{C}$ , $V_{IN} = 1.8\text{ V}$ , $2.5\text{ V}$ , $3.3\text{ V}$ , $5\text{ V}$ TPS60400, $C_I = C_{(fly)} = C_O = 1\text{ }\mu\text{F}$ TPS60401, $C_I = C_{(fly)} = C_O = 10\text{ }\mu\text{F}$ TPS60402, $C_I = C_{(fly)} = C_O = 3.3\text{ }\mu\text{F}$ TPS60403, $C_I = C_{(fly)} = C_O = 1\text{ }\mu\text{F}$	Figure 7-11, Figure 7-12, Figure 7-13, Figure 7-14

**Table 7-1. Table of Graphs (continued)**

			FIGURE
$f_{OSC}$	Oscillator frequency	vs Temperature at $V_I = 1.8\text{ V}, 2.5\text{ V}, 3.3\text{ V}, 5\text{ V}$ TPS60400, TPS60401, TPS60402, TPS60403	Figure 7-15, Figure 7-16, Figure 7-17, Figure 7-18
$f_{OSC}$	Oscillator frequency	vs Output current TPS60400 at 2 V, 3.3 V, 5.0 V	Figure 7-19

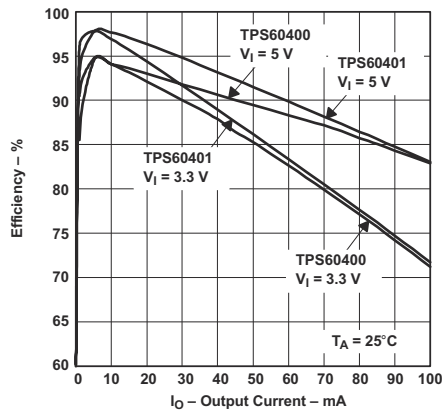

**Figure 7-1. Efficiency vs Output Current**

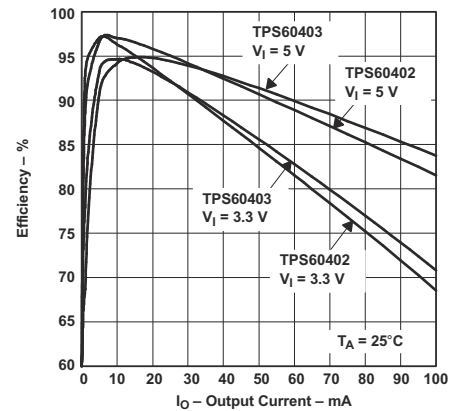

**Figure 7-2. Efficiency vs Output Current**

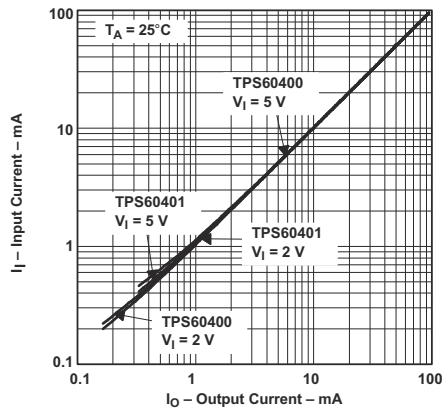

**Figure 7-3. Input Current vs Output Current**

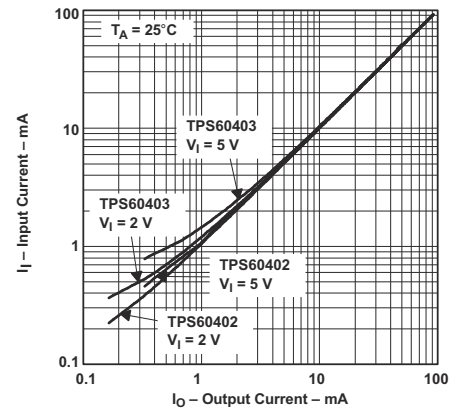

**Figure 7-4. Input Current vs Output Current**

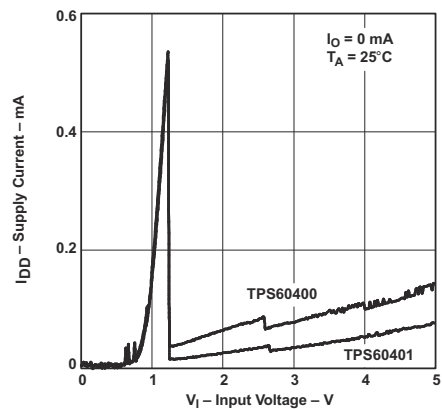

**Figure 7-5. Supply Current vs Input Voltage**

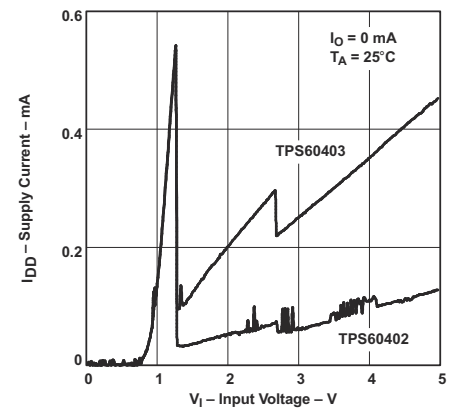

**Figure 7-6. Supply Current vs Input Voltage**

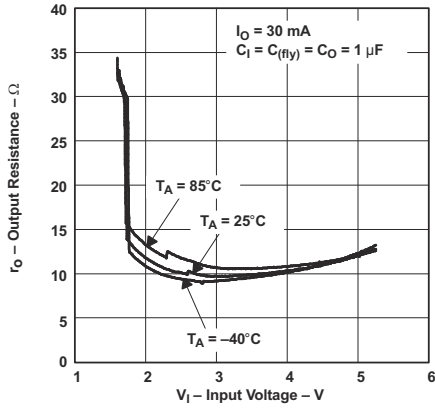

**Figure 7-7. Output Resistance vs Input Voltage**

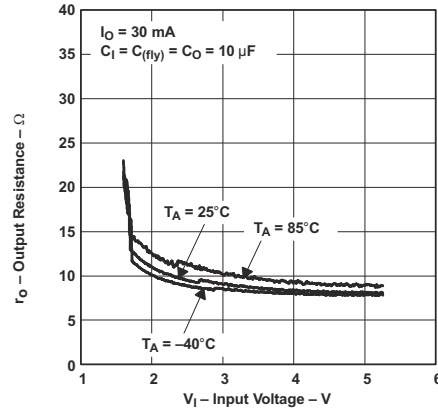

**Figure 7-8. Output Resistance vs Input Voltage**

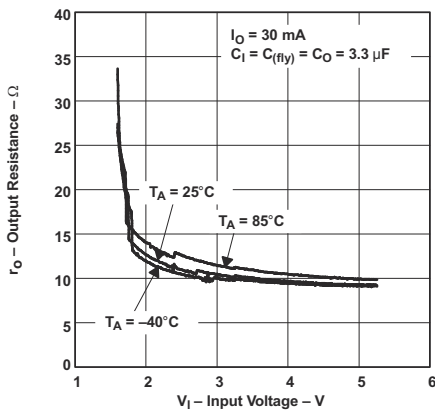

**Figure 7-9. Output Resistance vs Input Voltage**

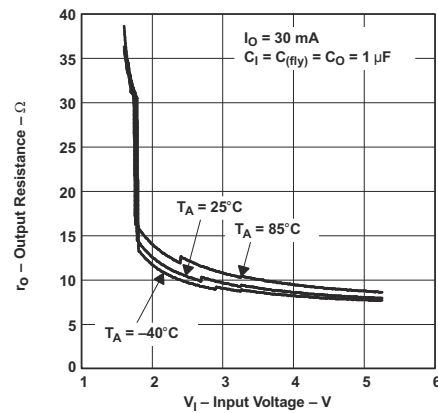

**Figure 7-10. Output Resistance vs Input Voltage**

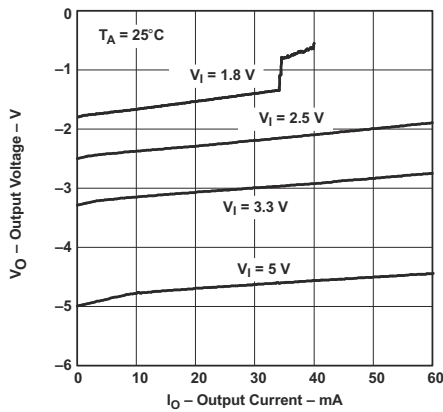

**Figure 7-11. Output Voltage vs Output Current**

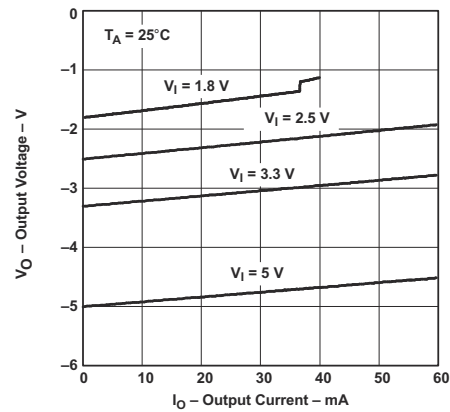

**Figure 7-12. Output Voltage vs Output Current**

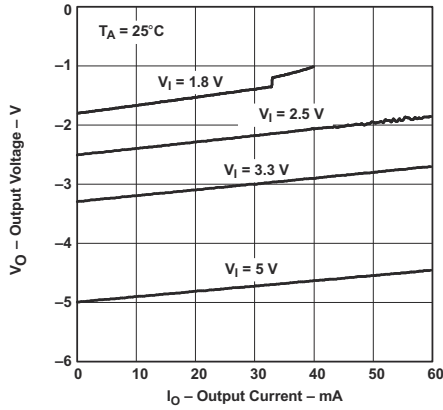

Figure 7-13. Output Voltage vs Output Current

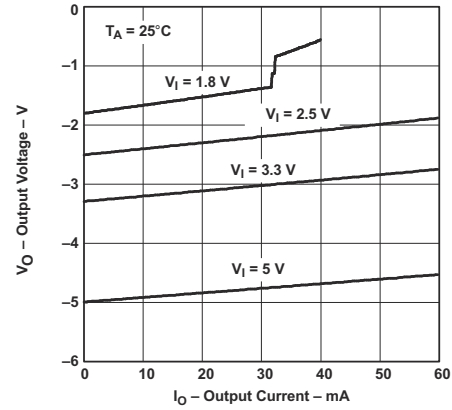

Figure 7-14. Output Voltage vs Output Current

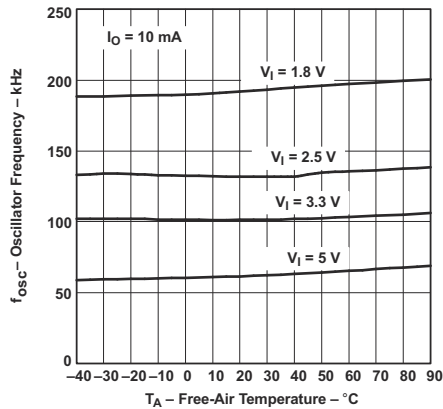

Figure 7-15. Oscillator Frequency vs Free-Air Temperature

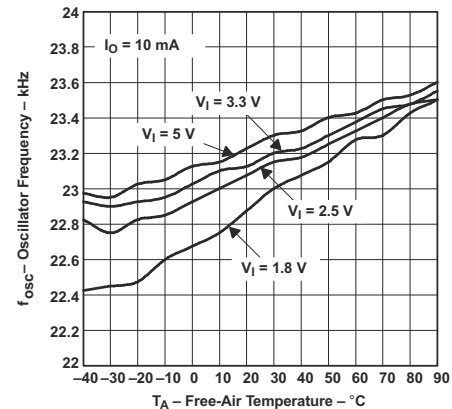

Figure 7-16. Oscillator Frequency vs Free-Air Temperature

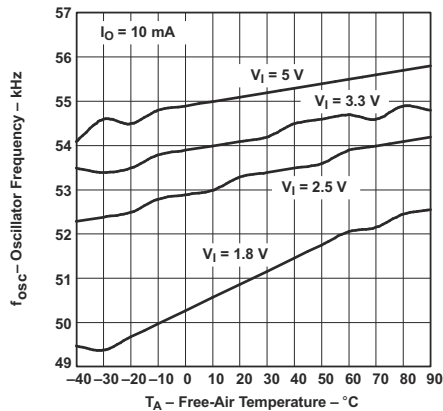

Figure 7-17. Oscillator Frequency vs Free-Air Temperature

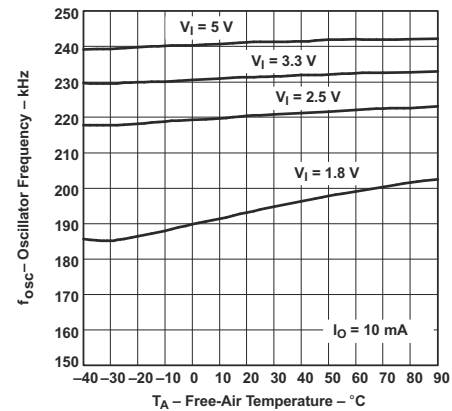
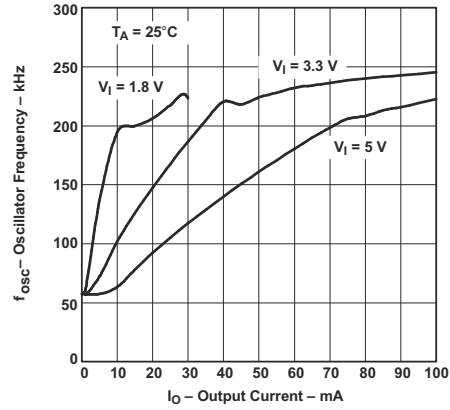

Figure 7-18. Oscillator Frequency vs Free-Air Temperature



**Figure 7-19. Oscillator Frequency vs Output Current**

## 8 Detailed Description

### 8.1 Overview

The TPS60400, TPS60401 charge pumps invert the voltage applied to their input. For the highest performance, use low equivalent series resistance (ESR) capacitors (for example, ceramic). During the first half-cycle, switches S2 and S4 open, switches S1 and S3 close, and capacitor ( $C_{(fly)}$ ) charges to the voltage at  $V_I$ . During the second half-cycle, S1 and S3 open, S2 and S4 close. This connects the positive terminal of  $C_{(fly)}$  to GND and the negative to  $V_O$ . By connecting  $C_{(fly)}$  in parallel,  $C_O$  is charged negative. The actual voltage at the output is more positive than  $-V_I$ , since switches S1-S4 have resistance and the load drains charge from  $C_O$ .

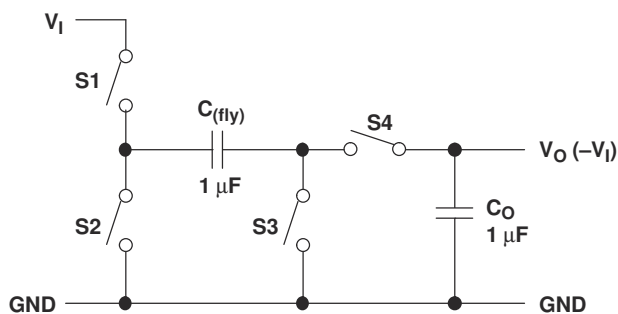
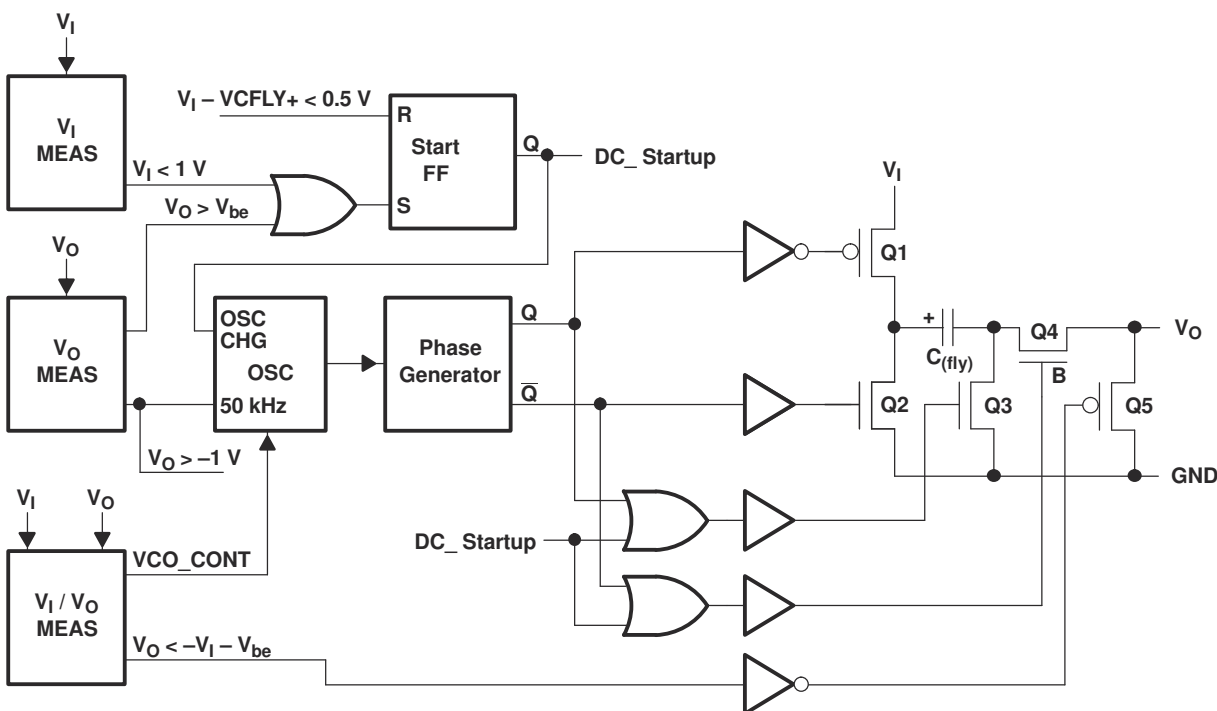

Figure 8-1. Operating Principle

### 8.2 Functional Block Diagram



## 8.3 Feature Description

### 8.3.1 Charge-Pump Output Resistance

The TPS6040x devices are not voltage regulators. The charge pump's output source resistance is approximately 15 Ω at room temperature (with  $V_I = 5\text{ V}$ ), and  $V_O$  approaches -5 V when lightly loaded.  $V_O$  droops toward GND as load current increases.

$$V_O = -(V_I - R_O \times I_O) \quad (1)$$

$$R_O \approx \frac{1}{f_{\text{osc}} \times C_{(\text{fly})}} + 4(2R_{\text{SWITCH}} + \text{ESR}_{\text{CFLY}}) + \text{ESR}_{\text{CO}}$$

$$R_O = \text{output resistance of the converter} \quad (2)$$

### 8.3.2 Efficiency Considerations

The power efficiency of a switched-capacitor voltage converter is affected by three factors: the internal losses in the converter IC, the resistive losses of the capacitors, and the conversion losses during charge transfer between the capacitors. The internal losses are associated with the internal functions of the IC, such as driving the switches, oscillator, and so forth. These losses are affected by operating conditions such as input voltage, temperature, and frequency. The next two losses are associated with the output resistance of the voltage converter circuit. Switch losses occur because of the on-resistance of the MOSFET switches in the IC. Charge-pump capacitor losses occur because of their ESR. The relationship between these losses and the output resistance is as follows:

$$P_{\text{CAPACITOR LOSSES}} + P_{\text{CONVERSION LOSSES}} = I_O^2 \times R_O$$

$$\begin{aligned} R_{\text{SWITCH}} &= \text{resistance of a single MOSFET-switch inside the converter} \\ f_{\text{OSC}} &= \text{oscillator frequency} \end{aligned} \quad (3)$$

The first term is the effective resistance from an ideal switched-capacitor circuit. Conversion losses occur during the charge transfer between  $C_{(\text{fly})}$  and  $C_O$  when there is a voltage difference between them. The power loss is:

$$P_{\text{CONV.LOSS}} = \left[ \frac{1}{2} \times C_{(\text{fly})} (V_I^2 - V_O^2) + \frac{1}{2} C_O (V_{\text{RIPPLE}}^2 - 2V_O V_{\text{RIPPLE}}) \right] \times f_{\text{osc}} \quad (4)$$

The efficiency of the TPS6040x devices is dominated by their quiescent supply current at low output current and by their output impedance at higher current.

$$\eta \cong \frac{I_O}{I_O + I_Q} \left( 1 - \frac{I_O \times R_O}{V_I} \right) \quad (5)$$

Where,  $I_Q$  = quiescent current.

## 8.4 Device Functional Modes

### 8.4.1 Active-Schottky Diode

For a short period of time, when the input voltage is applied, but the inverter is not yet working, the output capacitor is charged positive by the load. To prevent the output being pulled above GND, a Schottky diode must be added in parallel to the output. The function of this diode is integrated into the TPS6040x devices, which gives a defined startup performance and saves board space.

A current sink and a diode in series can approximate the behavior of a typical, modern operational amplifier. [Figure 8-2](#) shows the current into this typical load at a given voltage. The TPS6040x devices are optimized to start into these loads.

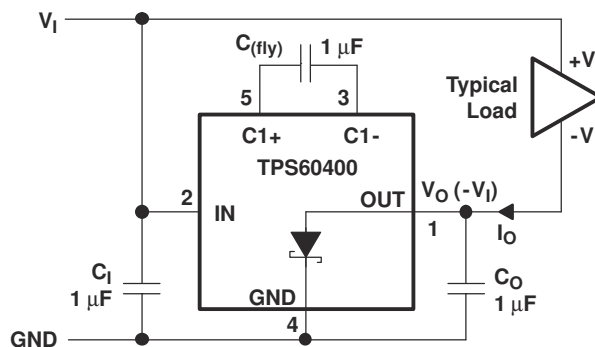

**Figure 8-2. Typical Load**

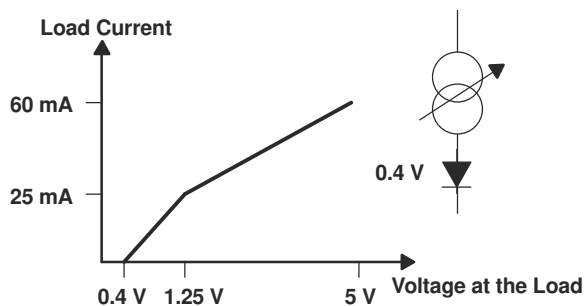

**Figure 8-3. Maximum Start-Up Current**

## 9 Application and Implementation

### Note

Information in the following applications sections is not part of the TI component specification, and TI does not warrant its accuracy or completeness. TI's customers are responsible for determining suitability of components for their purposes. Customers should validate and test their design implementation to confirm system functionality.

### 9.1 Application Information

The TPS6040x is a family of devices that generate an unregulated negative output voltage from an input voltage ranging from 1.6 V to 5.5 V.

### 9.2 Typical Application

#### 9.2.1 Voltage Inverter

The design guidelines provide a component selection to operate the device within the recommended operating conditions.

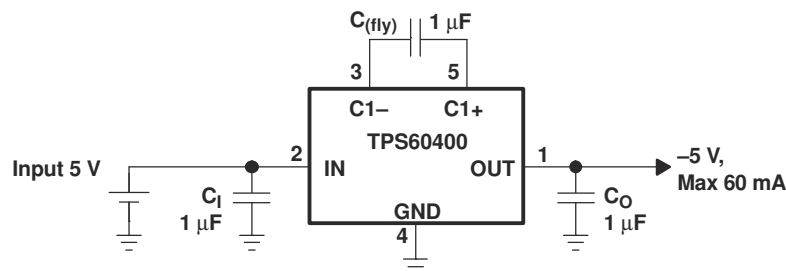

Figure 9-1. Typical Operating Circuit

#### 9.2.1.1 Design Requirements

The TPS6040x is connected to generate a negative output voltage from a positive input.

#### 9.2.1.2 Detailed Design Procedure

The most common application for these devices is a charge-pump voltage inverter (see Figure 9-1). This application requires only two external components; capacitors  $C_{(fly)}$  and  $C_O$ , plus a bypass capacitor, if necessary. Refer to the capacitor selection section for suggested capacitor types.

For the maximum output current and best performance, three ceramic capacitors of 1  $\mu\text{F}$  (TPS60400, TPS60403) are recommended. For lower currents or higher allowed output voltage ripple, other capacitors can also be used. It is recommended that the output capacitors has a minimum value of 1  $\mu\text{F}$ . With flying capacitors lower than 1  $\mu\text{F}$ , the maximum output power decreases.

##### 9.2.1.2.1 Capacitor Selection

To maintain the lowest output resistance, use capacitors with low ESR (see Table 9-1). The charge-pump output resistance is a function of  $C_{(fly)}$ 's and  $C_O$ 's ESR. Therefore, minimizing the charge-pump capacitor's ESR minimizes the total output resistance. The capacitor values are closely linked to the required output current and the output noise and ripple requirements. It is possible to only use 1- $\mu\text{F}$  capacitors of the same type.

##### 9.2.1.2.2 Input Capacitor ( $C_I$ )

Bypass the incoming supply to reduce its ac impedance and the impact of the TPS6040x switching noise. The recommended bypassing depends on the circuit configuration and where the load is connected. When the inverter is loaded from OUT to GND, current from the supply switches between  $2 \times I_O$  and zero. Therefore, use a large bypass capacitor (for example, equal to the value of  $C_{(fly)}$ ) if the supply has high ac impedance. When the inverter is loaded from IN to OUT, the circuit draws  $2 \times I_O$  constantly, except for short switching spikes. A 0.1- $\mu\text{F}$  bypass capacitor is sufficient.

### 9.2.1.2.3 Flying Capacitor (C<sub>(fly)</sub>)

Increasing the flying capacitor's size reduces the output resistance. Small values increases the output resistance. Above a certain point, increasing C<sub>(fly)</sub>'s capacitance has a negligible effect, because the output resistance becomes dominated by the internal switch resistance and capacitor ESR.

### 9.2.1.2.4 Output Capacitor (C<sub>O</sub>)

Increasing the output capacitor's size reduces the output ripple voltage. Decreasing its ESR reduces both output resistance and ripple. Smaller capacitance values can be used with light loads if higher output ripple can be tolerated. Use the following equation to calculate the peak-to-peak ripple.

$$V_{O(\text{ripple})} = \frac{I_O}{f_{\text{osc}} \times C_O} + 2 \times I_O \times \text{ESR}_{C_O} \quad (6)$$

**Table 9-1. Recommended Capacitor Values**

DEVICE	V <sub>I</sub> [V]	I <sub>O</sub> [mA]	C <sub>I</sub> [μF]	C <sub>(fly)</sub> [μF]	C <sub>O</sub> [μF]
TPS60400	1.8...5.5	60	1	1	1
TPS60401	1.8...5.5	60	10	10	10
TPS60402	1.8...5.5	60	3.3	3.3	3.3
TPS60403	1.8...5.5	60	1	1	1

**Table 9-2. Recommended Capacitors**

MANUFACTURER	PART NUMBER	SIZE	CAPACITANCE	TYPE
Taiyo Yuden	EMK212BJ474MG	0805	0.47 μF	Ceramic
	LMK212BJ105KG	0805	1 μF	Ceramic
	LMK212BJ225MG	0805	2.2 μF	Ceramic
	EMK316BJ225KL	1206	2.2 μF	Ceramic
	LMK316BJ475KL	1206	4.7 μF	Ceramic
	JMK316BJ106KL	1206	10 μF	Ceramic
TDK	C2012X5R1C105M	0805	1 μF	Ceramic
	C2012X5R1A225M	0805	2.2 μF	Ceramic
	C2012X5R1A335M	0805	3.3 μF	Ceramic

Table 9-3 contains a list of manufacturers of the recommended capacitors. Ceramic capacitors will provide the lowest output voltage ripple because they typically have the lowest ESR-rating.

**Table 9-3. Recommended Capacitor Manufacturers**

CAPACITOR TYPE	MANUFACTURER	WEB ADDRESS
X5R / X7R ceramic	Taiyo Yuden	www.t-yuden.com
X5R / X7R ceramic	TDK	www.component.tdk.com
X5R / X7R ceramic	Vishay	www.vishay.com
X5R / X7R ceramic	Kemet	www.kemet.com

### 9.2.1.2.5 Power Dissipation

As given in [Section 7.4](#), the thermal resistance of TPS6040x is:  $R_{\theta JA} = 221^{\circ}\text{C}/\text{W}$ .

The terminal resistance can be calculated using the following equation:

$$R_{\theta JA} = \frac{T_J - T_A}{P_D} \tag{7}$$

where:

$T_J$  is the junction temperature.  $T_A$  is the ambient temperature.  $P_D$  is the power that is dissipated by the device.

$$R_{\theta JA} = \frac{T_J - T_A}{P_D} \tag{8}$$

The maximum power dissipation can be calculated using the following equation:

$$P_D = V_I \times I_I - V_O \times I_O = V_{I(\text{max})} \times (I_O + I_{(\text{SUPPLY})}) - V_O \times I_O \tag{9}$$

The maximum power dissipation happens with maximum input voltage and maximum output current.

At maximum load the supply current is 0.7 mA maximum.

$$P_D = 5 \text{ V} \times (60 \text{ mA} + 0.7 \text{ mA}) - 4.4 \text{ V} \times 60 \text{ mA} = 40 \text{ mW} \tag{10}$$

With this maximum rating and the thermal resistance of the device on the EVM, the maximum temperature rise above ambient temperature can be calculated using the following equation:

$$\Delta T_J = R_{\theta JA} \times P_D = 221^{\circ}\text{C}/\text{W} \times 40 \text{ mW} = 8.8^{\circ}\text{C} \tag{11}$$

This means that the internal dissipation increases  $T_J$  by  $<10^{\circ}\text{C}$ .

The junction temperature of the device shall not exceed  $125^{\circ}\text{C}$ .

This means the IC can easily be used at ambient temperatures up to:

$$T_A = T_{J(\text{max})} - \Delta T_J = 125^{\circ}\text{C} - 10^{\circ}\text{C} = 115^{\circ}\text{C} \tag{12}$$

### 9.2.1.3 Application Curves

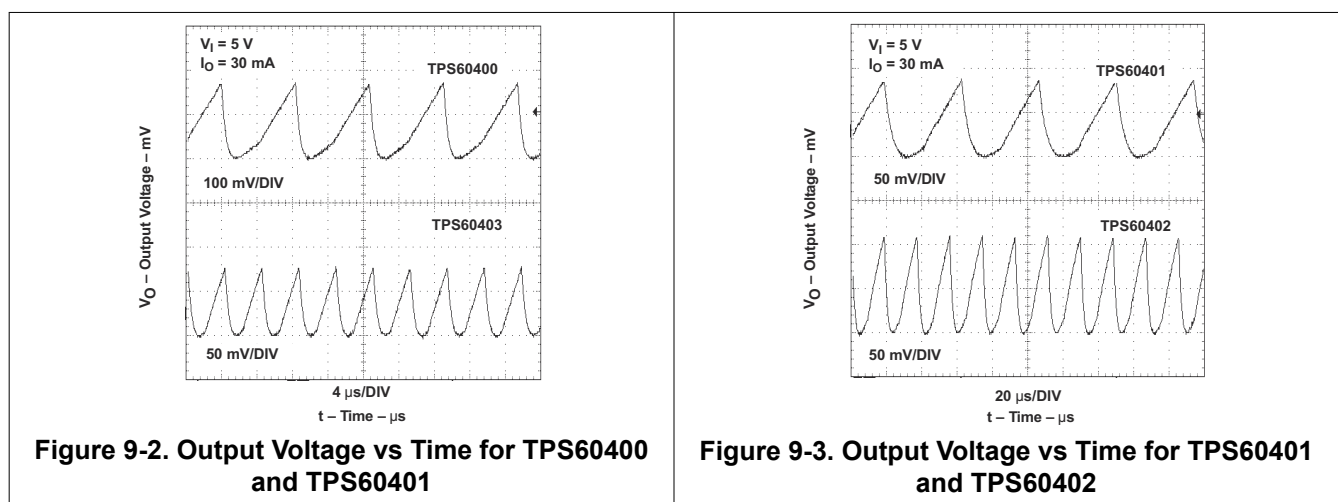

### 9.3 System Examples

To reduce the output voltage ripple, a RC post filter can be used.

An output filter can easily be formed with a resistor ( $R_P$ ) and a capacitor ( $C_P$ ). Cutoff frequency is given by:

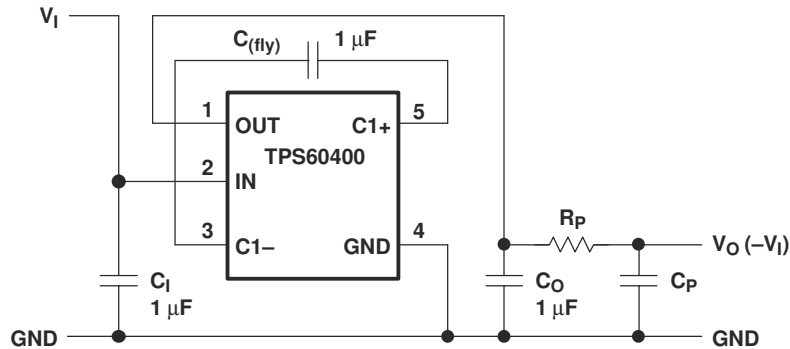

**Figure 9-4. TPS60400 with RC-Post Filter**

The equation refers only to the relation between output and input of the ac ripple voltages of the filter.

$$f_c = \frac{1}{2\pi R_P C_P} \quad (1)$$

and ratio  $V_O/V_{OUT}$  is:

$$\left| \frac{V_O}{V_{OUT}} \right| = \frac{1}{\sqrt{1 + (2\pi f R_P C_P)^2}} \quad (2)$$

with  $R_P = 50 \Omega$ ,  $C_P = 0.1 \mu\text{F}$  and  $f = 250 \text{ kHz}$ :  $\left| \frac{V_O}{V_{OUT}} \right| = 0.125$  (13)

To reduce the output voltage ripple, a LC post filter can be used.

Figure 9-5 shows a configuration with a LC-post filter to further reduce output ripple and noise.

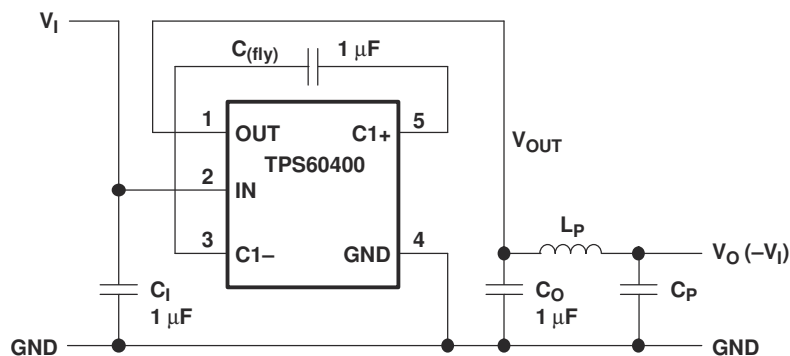

**Figure 9-5. LC-Post Filter**

The application allows to generate a voltage rail at a level of 1/2 of the input voltage.

A switched-capacitor voltage inverter can be configured as a high efficiency rail-splitter. This circuit provides a bipolar power supply that is useful in battery powered systems to supply dual-rail ICs, like operational amplifiers. Moreover, the SOT23-5 package and associated components require very little board space.

After power is applied, the flying capacitor ( $C_{(fly)}$ ) connects alternately across the output capacitors  $C_3$  and  $C_O$ . This equalizes the voltage on those capacitors and draws current from  $V_I$  to  $V_O$  as required to maintain the output at  $1/2 V_I$ .

The maximum input voltage between  $V_I$  and GND in the schematic (or between IN and OUT at the device itself) must not exceed 6.5 V.

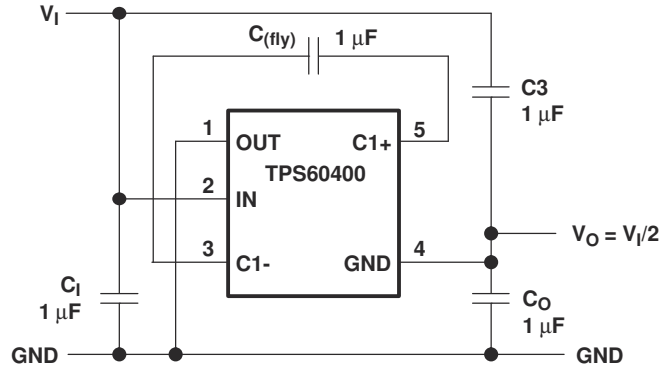

**Figure 9-6. TPS60400 as a High-Efficiency Rail Splitter**

The application allows to generate a voltage rail at a level of  $-V_I$  as well as  $2 \times V_I$  ( $V_{(pos)}$ ).

In the circuit of [Figure 9-7](#), capacitors  $C_1$ ,  $C_{(fly)}$ , and  $C_O$  form the inverter, while  $C_1$  and  $C_2$  form the doubler.  $C_1$  and  $C_{(fly)}$  are the flying capacitors;  $C_O$  and  $C_2$  are the output capacitors. Because both the inverter and doubler use part of the charge-pump circuit, loading either output causes both outputs to decline toward GND. Make sure the sum of the currents drawn from the two outputs does not exceed 60 mA. The maximum output current at  $V_{(pos)}$  must not exceed 30 mA. If the negative output is loaded, this current must be further reduced.

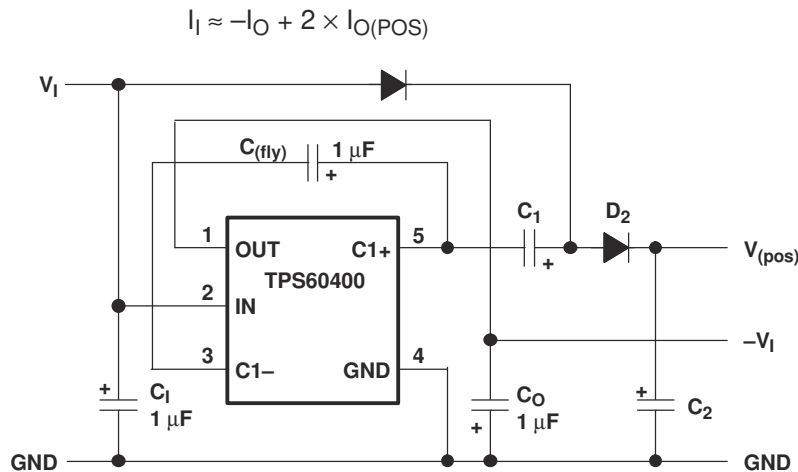

**Figure 9-7. TPS60400 as Doubler/Inverter**

The application generate a voltage rail at a level  $-2 \times V_I$ .

Two devices can be cascaded to produce an even larger negative voltage (see [Figure 9-8](#)). The unloaded output voltage is normally  $-2 \times V_I$ , but this is reduced slightly by the output resistance of the first device multiplied by the quiescent current of the second. When cascading more than two devices, the output resistance rises dramatically.

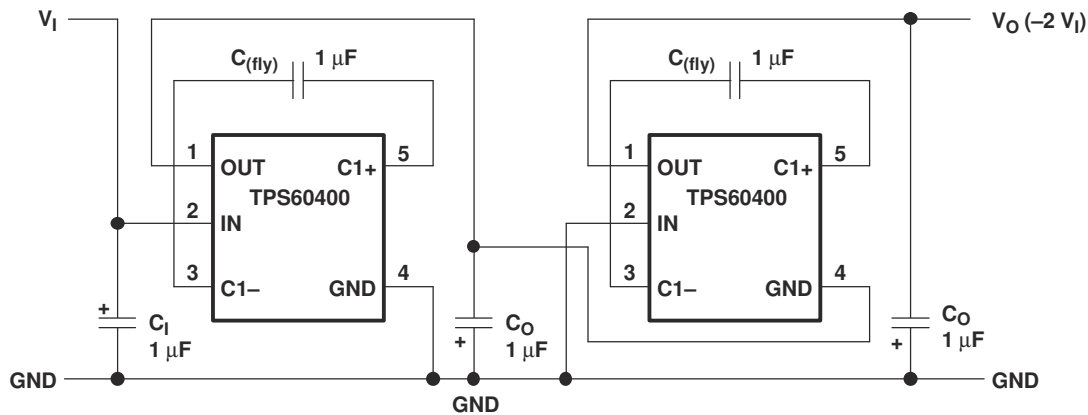

**Figure 9-8. Doubling Inverter**

The application allows to increase the output current by using two or more in parallel.

Paralleling multiple TPS6040xs reduces the output resistance. Each device requires its own flying capacitor ( $C_{(fly)}$ ), but the output capacitor ( $C_O$ ) serves all devices (see Figure 9-9). Increase  $C_O$ 's value by a factor of  $n$ , where  $n$  is the number of parallel devices. Equation 1 shows the equation for calculating output resistance.

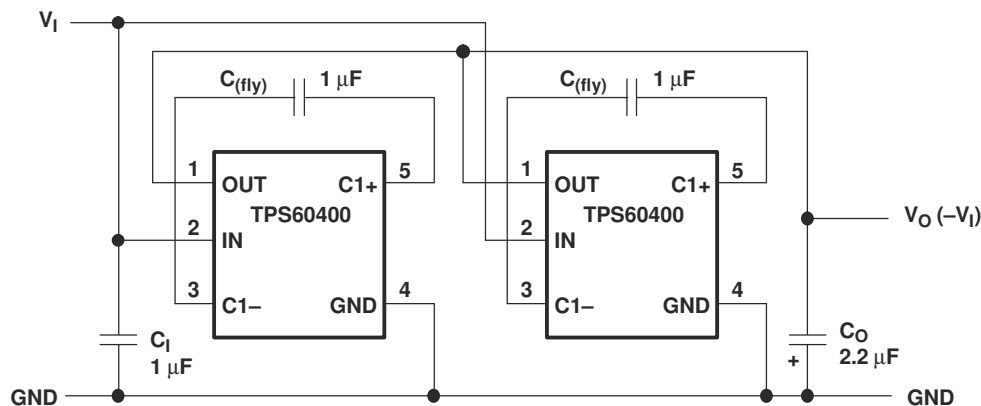
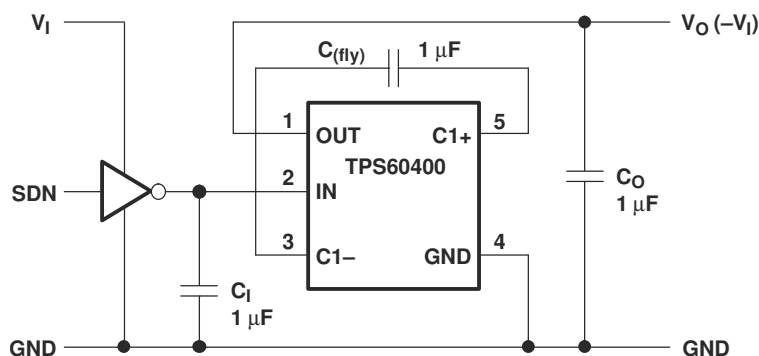

**Figure 9-9. Paralleling Devices**

The application adds a shutdown function.

If shutdown is necessary, use the circuit in Figure 9-10. The output resistance of the TPS6040x typically is  $15 \Omega$  plus two times the output resistance of the buffer.

Connecting multiple buffers in parallel reduces the output resistance of the buffer driving the IN pin.



**Figure 9-10. Shutdown Control**

The application generates a regulated output voltage for a GaAs bias supply.

A solution for a -2.7-V/3-mA GaAs bias supply is proposed in Figure 9-11. The input voltage of 3.3 V is first inverted with a TPS60403 and stabilized using a TLV431 low-voltage shunt regulator. Resistor  $R_P$  with capacitor  $C_P$  is used for filtering the output voltage.

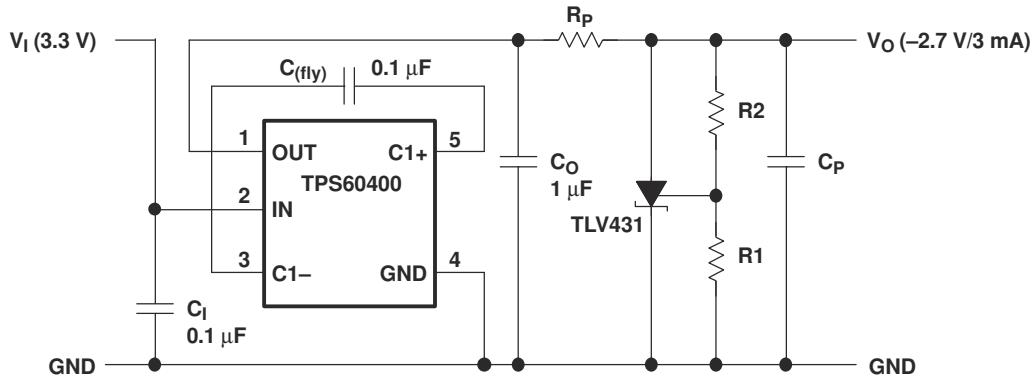

**Figure 9-11. GaAs Supply**

A 0.1- $\mu\text{F}$  capacitor was selected for  $C_{\text{fly}}$ . By this, the output resistance of the inverter is about 52  $\Omega$ .

$R_{\text{PMAX}}$  can be calculated using the following equation:

$$V_O = - \left( 1 + \frac{R_1}{R_2} \right) \times V_{\text{ref}} - R_1 \times I_{\text{l(ref)}} \quad (14)$$

A 100- $\Omega$  resistor was selected for  $R_P$ .

The reference voltage across  $R_2$  is 1.24 V typical. With 5- $\mu\text{A}$  current for the voltage divider,  $R_2$  gets:

$$R_{\text{PMAX}} = \left( \frac{V_{\text{CO}} - V_O}{I_O} - R_O \right)$$

With:  $V_{\text{CO}} = -3.3 \text{ V}$ ;  $V_O = -2.7 \text{ V}$ ;  $I_O = -3 \text{ mA}$

$$R_{\text{PMAX}} = 200 \Omega - 52 \Omega = 148 \Omega \quad (15)$$

With  $C_P = 1 \mu\text{F}$  the ratio  $V_O/V_I$  of the RC post filter is:

$$R_2 = \frac{1.24 \text{ V}}{5 \mu\text{A}} \approx 250 \text{ k}\Omega$$

$$R_1 = \frac{2.7 - 1.24 \text{ V}}{5 \mu\text{A}} \approx 300 \text{ k}\Omega \quad (16)$$

$$\left| \frac{V_O}{V_I} \right| = \frac{1}{\sqrt{1 + (2\pi 125000\text{Hz} \times 100\Omega \times 1 \mu\text{F})^2}} \approx 0.01 \quad (17)$$

The application generates an output voltage of 1/2 of the input voltage.

By exchanging GND with OUT (connecting the GND pin with OUT and the OUT pin with GND), a step-down charge pump can easily be formed. In the first cycle  $S_1$  and  $S_3$  are closed, and  $C_{\text{fly}}$  with  $C_O$  in series are charged. Assuming the same capacitance, the voltage across  $C_{\text{fly}}$  and  $C_O$  is split equally between the capacitors. In the second cycle,  $S_2$  and  $S_4$  close and both capacitors with  $V_I/2$  across are connected in parallel.

The maximum input voltage between  $V_I$  and GND in the schematic (or between IN and OUT at the device itself) must not exceed 6.5 V. For input voltages in the range of 6.5 V to 11 V, an additional Zener-diode is recommended (see Figure 9-14).

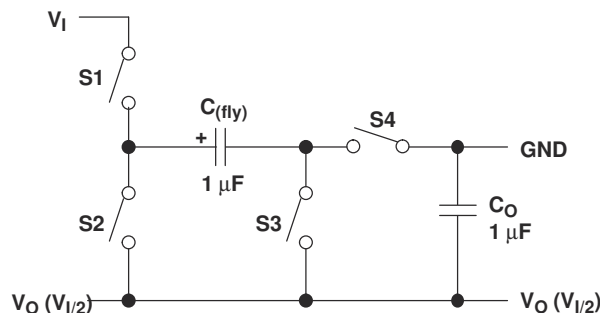

Figure 9-12. Step-Down Principle

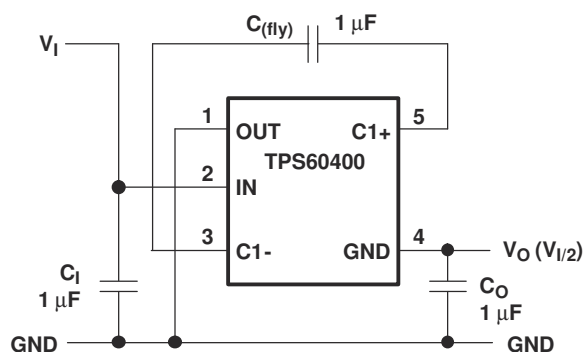

Figure 9-13. Step-Down Charge Pump Connection

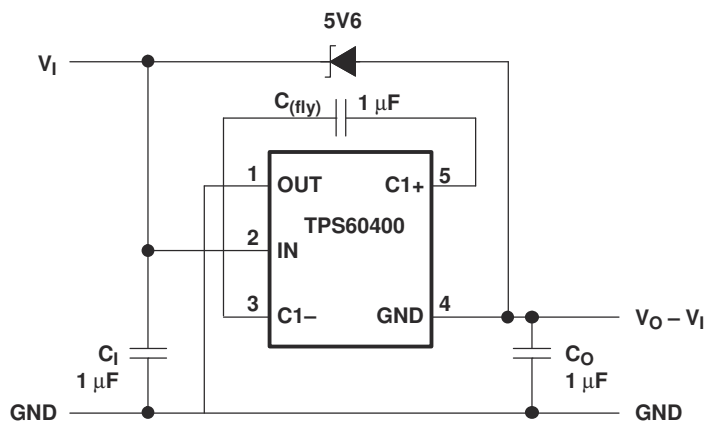

Figure 9-14. Step-Down Charge Pump Connection for Higher Input Voltages

## 10 Power Supply Recommendations

The TPS60400 device family has no special requirements for its power supply. The power supply output needs to be rated according to the supply voltage, output voltage and output current of the TPS6040x.

## 11 Layout

### 11.1 Layout Guidelines

All capacitors should be soldered as close as possible to the IC. A PCB layout proposal for a single-layer board is shown in [Figure 11-1](#). Care has been taken to connect all capacitors as close as possible to the circuit to achieve optimized output voltage ripple performance.

### 11.2 Layout Example

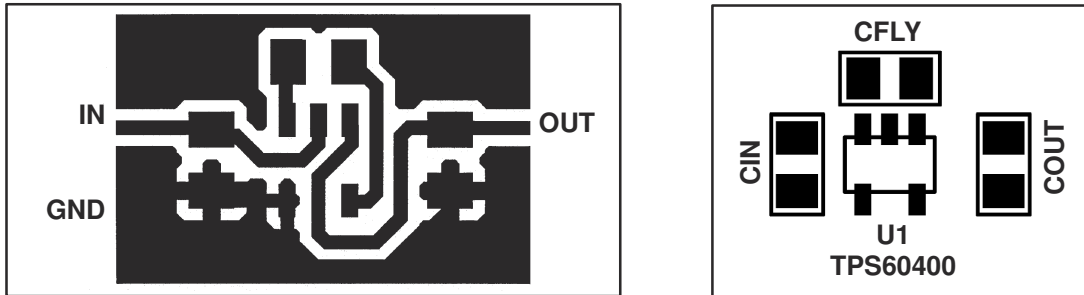

Figure 11-1. Recommended PCB Layout for TPS6040x (Top Layer)

## 12 Device and Documentation Support

### 12.1 Device Support

#### 12.1.1 Third-Party Products Disclaimer

TI'S PUBLICATION OF INFORMATION REGARDING THIRD-PARTY PRODUCTS OR SERVICES DOES NOT CONSTITUTE AN ENDORSEMENT REGARDING THE SUITABILITY OF SUCH PRODUCTS OR SERVICES OR A WARRANTY, REPRESENTATION OR ENDORSEMENT OF SUCH PRODUCTS OR SERVICES, EITHER ALONE OR IN COMBINATION WITH ANY TI PRODUCT OR SERVICE.

#### 12.1.2 Device Family Products

Other inverting DC-DC converters from Texas Instruments are listed in [Table 12-1](#).

**Table 12-1. Product Identification**

PART NUMBER	DESCRIPTION
<a href="#">TPS6735</a>	Fixed negative 5-V, 200-mA inverting dc-dc converter
<a href="#">TPS6755</a>	Adjustable 1-W inverting dc-dc converter

### 12.2 Related Links

The table below lists quick access links. Categories include technical documents, support and community resources, tools and software, and quick access to sample or buy.

**Table 12-2. Related Links**

PARTS	PRODUCT FOLDER	SAMPLE & BUY	TECHNICAL DOCUMENTS	TOOLS & SOFTWARE	SUPPORT & COMMUNITY
TPS60400	<a href="#">Click here</a>	<a href="#">Click here</a>	<a href="#">Click here</a>	<a href="#">Click here</a>	<a href="#">Click here</a>
TPS60401	<a href="#">Click here</a>	<a href="#">Click here</a>	<a href="#">Click here</a>	<a href="#">Click here</a>	<a href="#">Click here</a>
TPS60402	<a href="#">Click here</a>	<a href="#">Click here</a>	<a href="#">Click here</a>	<a href="#">Click here</a>	<a href="#">Click here</a>
TPS60403	<a href="#">Click here</a>	<a href="#">Click here</a>	<a href="#">Click here</a>	<a href="#">Click here</a>	<a href="#">Click here</a>

### 12.3 Trademarks

All other trademarks are the property of their respective owners.

### 12.4 Electrostatic Discharge Caution



This integrated circuit can be damaged by ESD. Texas Instruments recommends that all integrated circuits be handled with appropriate precautions. Failure to observe proper handling and installation procedures can cause damage.

ESD damage can range from subtle performance degradation to complete device failure. Precision integrated circuits may be more susceptible to damage because very small parametric changes could cause the device not to meet its published specifications.

### 12.5 Glossary

**TI Glossary** This glossary lists and explains terms, acronyms, and definitions.

## 13 Mechanical, Packaging, and Orderable Information

The following pages include mechanical, packaging, and orderable information. This information is the most current data available for the designated devices. This data is subject to change without notice and revision of this document. For browser-based versions of this data sheet, refer to the left-hand navigation.

**PACKAGING INFORMATION**

Orderable Device	Status (1)	Package Type	Package Drawing	Pins	Package Qty	Eco Plan (2)	Lead finish/ Ball material (6)	MSL Peak Temp (3)	Op Temp (°C)	Device Marking (4/5)	Samples
TPS60400DBVR	ACTIVE	SOT-23	DBV	5	3000	RoHS & Green	NIPDAU   SN	Level-1-260C-UNLIM	-40 to 85	PFKI	<a href="#">Samples</a>
TPS60400DBVRG4	ACTIVE	SOT-23	DBV	5	3000	RoHS & Green	SN	Level-1-260C-UNLIM	-40 to 85	PFKI	<a href="#">Samples</a>
TPS60400DBVT	ACTIVE	SOT-23	DBV	5	250	RoHS & Green	NIPDAU   SN	Level-1-260C-UNLIM	-40 to 85	PFKI	<a href="#">Samples</a>
TPS60400DBVTG4	ACTIVE	SOT-23	DBV	5	250	RoHS & Green	SN	Level-1-260C-UNLIM	-40 to 85	PFKI	<a href="#">Samples</a>
TPS60401DBVR	ACTIVE	SOT-23	DBV	5	3000	RoHS & Green	NIPDAU   SN	Level-1-260C-UNLIM	-40 to 85	PFLI	<a href="#">Samples</a>
TPS60401DBVRG4	ACTIVE	SOT-23	DBV	5	3000	RoHS & Green	SN	Level-1-260C-UNLIM	-40 to 85	PFLI	<a href="#">Samples</a>
TPS60401DBVT	ACTIVE	SOT-23	DBV	5	250	RoHS & Green	NIPDAU   SN	Level-1-260C-UNLIM	-40 to 85	PFLI	<a href="#">Samples</a>
TPS60401DBVTG4	ACTIVE	SOT-23	DBV	5	250	RoHS & Green	SN	Level-1-260C-UNLIM	-40 to 85	PFLI	<a href="#">Samples</a>
TPS60402DBVR	ACTIVE	SOT-23	DBV	5	3000	RoHS & Green	NIPDAU   SN	Level-1-260C-UNLIM	-40 to 85	PFMI	<a href="#">Samples</a>
TPS60402DBVRG4	ACTIVE	SOT-23	DBV	5	3000	RoHS & Green	SN	Level-1-260C-UNLIM	-40 to 85	PFMI	<a href="#">Samples</a>
TPS60402DBVT	ACTIVE	SOT-23	DBV	5	250	RoHS & Green	NIPDAU   SN	Level-1-260C-UNLIM	-40 to 85	PFMI	<a href="#">Samples</a>
TPS60402DBVTG4	ACTIVE	SOT-23	DBV	5	250	RoHS & Green	SN	Level-1-260C-UNLIM	-40 to 85	PFMI	<a href="#">Samples</a>
TPS60403DBVR	ACTIVE	SOT-23	DBV	5	3000	RoHS & Green	NIPDAU   SN	Level-1-260C-UNLIM	-40 to 85	PFNI	<a href="#">Samples</a>
TPS60403DBVRG4	ACTIVE	SOT-23	DBV	5	3000	RoHS & Green	SN	Level-1-260C-UNLIM	-40 to 85	PFNI	<a href="#">Samples</a>
TPS60403DBVT	ACTIVE	SOT-23	DBV	5	250	RoHS & Green	NIPDAU   SN	Level-1-260C-UNLIM	-40 to 85	PFNI	<a href="#">Samples</a>
TPS60403DBVTG4	ACTIVE	SOT-23	DBV	5	250	RoHS & Green	SN	Level-1-260C-UNLIM	-40 to 85	PFNI	<a href="#">Samples</a>

(1) The marketing status values are defined as follows:

**ACTIVE:** Product device recommended for new designs.

**LIFEBUY:** TI has announced that the device will be discontinued, and a lifetime-buy period is in effect.

**NRND:** Not recommended for new designs. Device is in production to support existing customers, but TI does not recommend using this part in a new design.

**PREVIEW:** Device has been announced but is not in production. Samples may or may not be available.

**OBSELETE:** TI has discontinued the production of the device.

(2) **RoHS:** TI defines "RoHS" to mean semiconductor products that are compliant with the current EU RoHS requirements for all 10 RoHS substances, including the requirement that RoHS substance do not exceed 0.1% by weight in homogeneous materials. Where designed to be soldered at high temperatures, "RoHS" products are suitable for use in specified lead-free processes. TI may reference these types of products as "Pb-Free".

**RoHS Exempt:** TI defines "RoHS Exempt" to mean products that contain lead but are compliant with EU RoHS pursuant to a specific EU RoHS exemption.

**Green:** TI defines "Green" to mean the content of Chlorine (Cl) and Bromine (Br) based flame retardants meet JS709B low halogen requirements of  $\leq 1000$ ppm threshold. Antimony trioxide based flame retardants must also meet the  $\leq 1000$ ppm threshold requirement.

(3) MSL, Peak Temp. - The Moisture Sensitivity Level rating according to the JEDEC industry standard classifications, and peak solder temperature.

(4) There may be additional marking, which relates to the logo, the lot trace code information, or the environmental category on the device.

(5) Multiple Device Markings will be inside parentheses. Only one Device Marking contained in parentheses and separated by a "~" will appear on a device. If a line is indented then it is a continuation of the previous line and the two combined represent the entire Device Marking for that device.

(6) Lead finish/Ball material - Orderable Devices may have multiple material finish options. Finish options are separated by a vertical ruled line. Lead finish/Ball material values may wrap to two lines if the finish value exceeds the maximum column width.

**Important Information and Disclaimer:** The information provided on this page represents TI's knowledge and belief as of the date that it is provided. TI bases its knowledge and belief on information provided by third parties, and makes no representation or warranty as to the accuracy of such information. Efforts are underway to better integrate information from third parties. TI has taken and continues to take reasonable steps to provide representative and accurate information but may not have conducted destructive testing or chemical analysis on incoming materials and chemicals. TI and TI suppliers consider certain information to be proprietary, and thus CAS numbers and other limited information may not be available for release.

In no event shall TI's liability arising out of such information exceed the total purchase price of the TI part(s) at issue in this document sold by TI to Customer on an annual basis.

**OTHER QUALIFIED VERSIONS OF TPS60400, TPS60401, TPS60402, TPS60403 :**

- Automotive : [TPS60400-Q1](#), [TPS60401-Q1](#), [TPS60402-Q1](#), [TPS60403-Q1](#)

NOTE: Qualified Version Definitions:

- Automotive - Q100 devices qualified for high-reliability automotive applications targeting zero defects

**TAPE AND REEL INFORMATION**

**QUADRANT ASSIGNMENTS FOR PIN 1 ORIENTATION IN TAPE**

\*All dimensions are nominal

Device	Package Type	Package Drawing	Pins	SPQ	Reel Diameter (mm)	Reel Width W1 (mm)	A0 (mm)	B0 (mm)	K0 (mm)	P1 (mm)	W (mm)	Pin1 Quadrant
TPS60400DBVR	SOT-23	DBV	5	3000	180.0	8.4	3.2	3.2	1.4	4.0	8.0	Q3
TPS60400DBVT	SOT-23	DBV	5	250	180.0	8.4	3.2	3.2	1.4	4.0	8.0	Q3
TPS60401DBVR	SOT-23	DBV	5	3000	180.0	8.4	3.2	3.2	1.4	4.0	8.0	Q3
TPS60401DBVT	SOT-23	DBV	5	250	180.0	8.4	3.2	3.2	1.4	4.0	8.0	Q3
TPS60402DBVR	SOT-23	DBV	5	3000	180.0	8.4	3.2	3.2	1.4	4.0	8.0	Q3
TPS60402DBVT	SOT-23	DBV	5	250	180.0	8.4	3.2	3.2	1.4	4.0	8.0	Q3
TPS60403DBVR	SOT-23	DBV	5	3000	180.0	8.4	3.2	3.2	1.4	4.0	8.0	Q3
TPS60403DBVT	SOT-23	DBV	5	250	180.0	8.4	3.2	3.2	1.4	4.0	8.0	Q3

**TAPE AND REEL BOX DIMENSIONS**

\*All dimensions are nominal

Device	Package Type	Package Drawing	Pins	SPQ	Length (mm)	Width (mm)	Height (mm)
TPS60400DBVR	SOT-23	DBV	5	3000	210.0	185.0	35.0
TPS60400DBVT	SOT-23	DBV	5	250	210.0	185.0	35.0
TPS60401DBVR	SOT-23	DBV	5	3000	210.0	185.0	35.0
TPS60401DBVT	SOT-23	DBV	5	250	210.0	185.0	35.0
TPS60402DBVR	SOT-23	DBV	5	3000	210.0	185.0	35.0
TPS60402DBVT	SOT-23	DBV	5	250	210.0	185.0	35.0
TPS60403DBVR	SOT-23	DBV	5	3000	210.0	185.0	35.0
TPS60403DBVT	SOT-23	DBV	5	250	210.0	185.0	35.0

# DBV0005A



# PACKAGE OUTLINE

## SOT-23 - 1.45 mm max height

SMALL OUTLINE TRANSISTOR

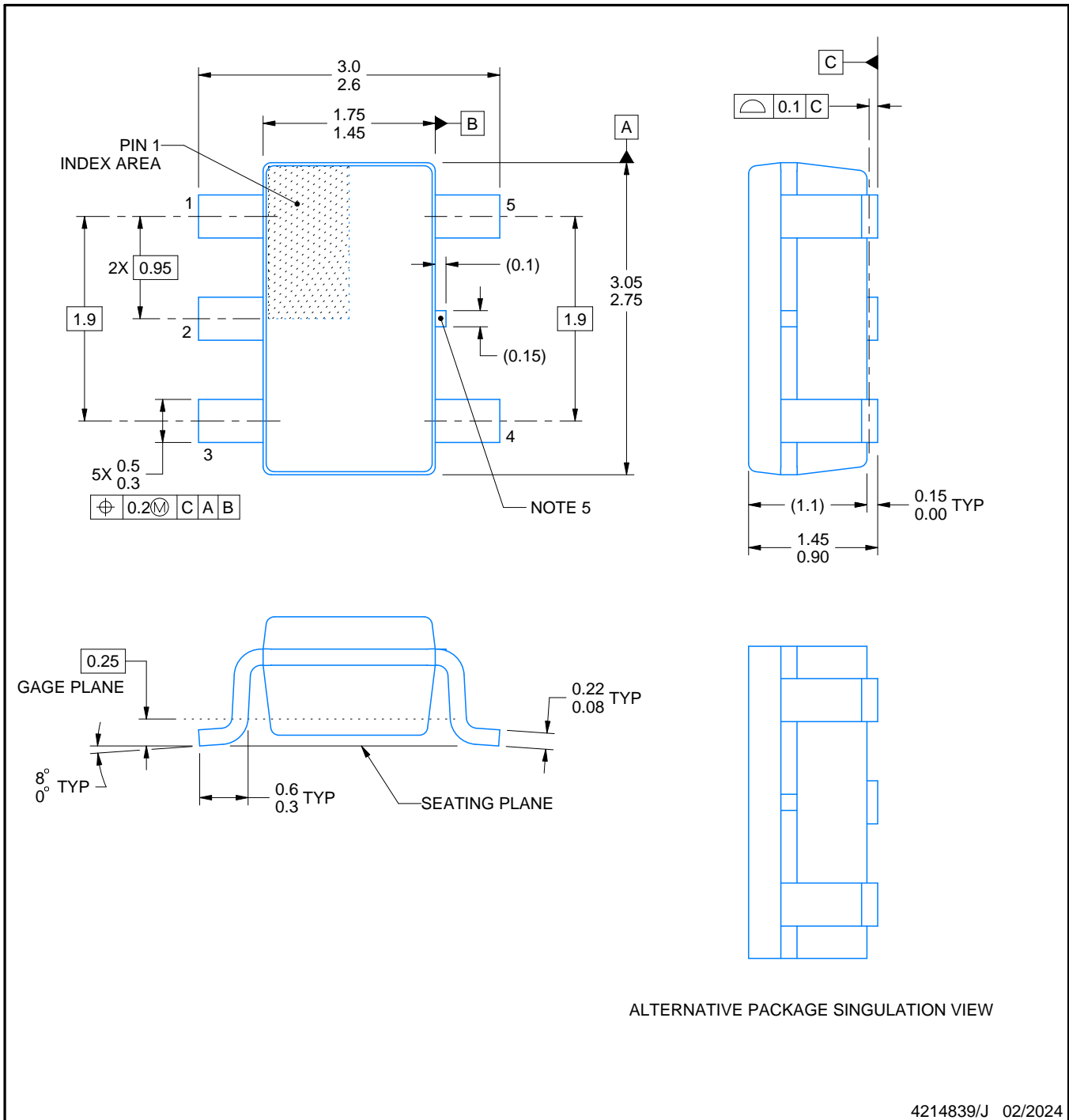

4214839/J 02/2024

### NOTES:

1. All linear dimensions are in millimeters. Any dimensions in parenthesis are for reference only. Dimensioning and tolerancing per ASME Y14.5M.
2. This drawing is subject to change without notice.
3. Reference JEDEC MO-178.
4. Body dimensions do not include mold flash, protrusions, or gate burrs. Mold flash, protrusions, or gate burrs shall not exceed 0.25 mm per side.
5. Support pin may differ or may not be present.

# EXAMPLE BOARD LAYOUT

DBV0005A

SOT-23 - 1.45 mm max height

SMALL OUTLINE TRANSISTOR



LAND PATTERN EXAMPLE  
EXPOSED METAL SHOWN  
SCALE:15X

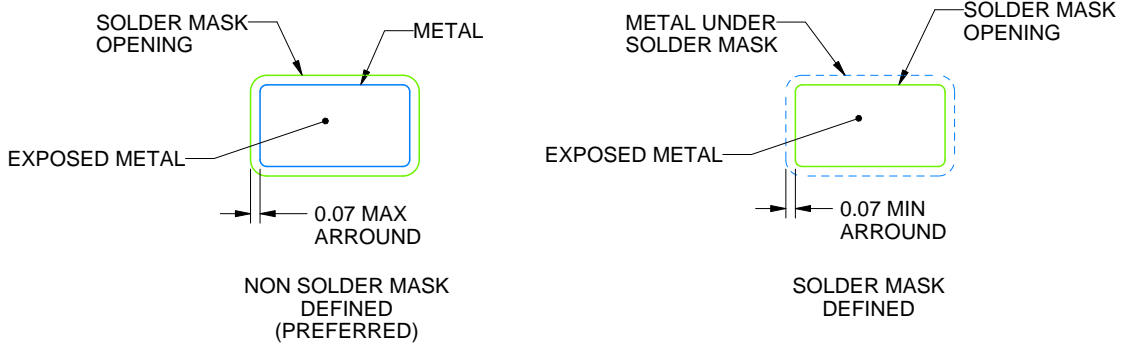

SOLDER MASK DETAILS

4214839/J 02/2024

NOTES: (continued)

6. Publication IPC-7351 may have alternate designs.
7. Solder mask tolerances between and around signal pads can vary based on board fabrication site.

# EXAMPLE STENCIL DESIGN

DBV0005A

SOT-23 - 1.45 mm max height

SMALL OUTLINE TRANSISTOR



SOLDER PASTE EXAMPLE  
BASED ON 0.125 mm THICK STENCIL  
SCALE:15X

4214839/J 02/2024

NOTES: (continued)

8. Laser cutting apertures with trapezoidal walls and rounded corners may offer better paste release. IPC-7525 may have alternate design recommendations.
9. Board assembly site may have different recommendations for stencil design.

## IMPORTANT NOTICE AND DISCLAIMER

TI PROVIDES TECHNICAL AND RELIABILITY DATA (INCLUDING DATA SHEETS), DESIGN RESOURCES (INCLUDING REFERENCE DESIGNS), APPLICATION OR OTHER DESIGN ADVICE, WEB TOOLS, SAFETY INFORMATION, AND OTHER RESOURCES "AS IS" AND WITH ALL FAULTS, AND DISCLAIMS ALL WARRANTIES, EXPRESS AND IMPLIED, INCLUDING WITHOUT LIMITATION ANY IMPLIED WARRANTIES OF MERCHANTABILITY, FITNESS FOR A PARTICULAR PURPOSE OR NON-INFRINGEMENT OF THIRD PARTY INTELLECTUAL PROPERTY RIGHTS.

These resources are intended for skilled developers designing with TI products. You are solely responsible for (1) selecting the appropriate TI products for your application, (2) designing, validating and testing your application, and (3) ensuring your application meets applicable standards, and any other safety, security, regulatory or other requirements.

These resources are subject to change without notice. TI grants you permission to use these resources only for development of an application that uses the TI products described in the resource. Other reproduction and display of these resources is prohibited. No license is granted to any other TI intellectual property right or to any third party intellectual property right. TI disclaims responsibility for, and you will fully indemnify TI and its representatives against, any claims, damages, costs, losses, and liabilities arising out of your use of these resources.

TI's products are provided subject to [TI's Terms of Sale](#) or other applicable terms available either on [ti.com](https://www.ti.com) or provided in conjunction with such TI products. TI's provision of these resources does not expand or otherwise alter TI's applicable warranties or warranty disclaimers for TI products.

TI objects to and rejects any additional or different terms you may have proposed.

Mailing Address: Texas Instruments, Post Office Box 655303, Dallas, Texas 75265  
Copyright © 2024, Texas Instruments Incorporated





## Looking for pricing, stock, or lifecycle information?

Click below to explore more details on WIN SOURCE:

 [View TPS60402DBVR](#) on WIN SOURCE

 [Texas Instruments](#) Information

## Optimize Your Supply Chain with WIN SOURCE Solutions

-  Global Sourcing Solution
-  Obsolete Management
-  Cost Control Management
-  Shortage Management
-  Alternative Solution
-  Excess Inventory Management