



**THE DATASHEET OF
TPS61087DRCR**



TPS61087 650-kHz, 1.2-MHz, 18.5-V Step-Up DC-DC Converter With 3.2-A Switch

1 Features

- 2.5-V to 6-V Input Voltage Range
- 18.5-V Boost Converter With 3.2-A Switch Current
- 650-kHz, 1.2-MHz Selectable Switching Frequency
- Adjustable Soft-Start
- Thermal Shutdown
- Undervoltage Lockout
- 10-Pin QFN and Thin QFN Packages

2 Applications

- Handheld Devices
- GPS Receivers
- Digital Still Cameras
- Portable Applications
- DSL Modems
- PCMCIA Cards
- TFT LCD Bias Supply

3 Description

The TPS61087 is a high-frequency, high-efficiency DC-DC converter with an integrated 3.2-A, 0.13-Ω power switch capable of providing an output voltage up to 18.5 V. The selectable frequency of 650 kHz or 1.2 MHz allows the use of small external inductors and capacitors and provides fast transient response. The external compensation allows optimization of the application for specific conditions. A capacitor connected to the soft-start pin minimizes inrush current at startup.

Device Information⁽¹⁾

PART NUMBER	PACKAGE	BODY SIZE (NOM)
TPS61087	VSON (10)	3.00 mm × 3.00 mm
	WSON (10)	

(1) For all available packages, see the orderable addendum at the end of the datasheet.

Simplified Schematic

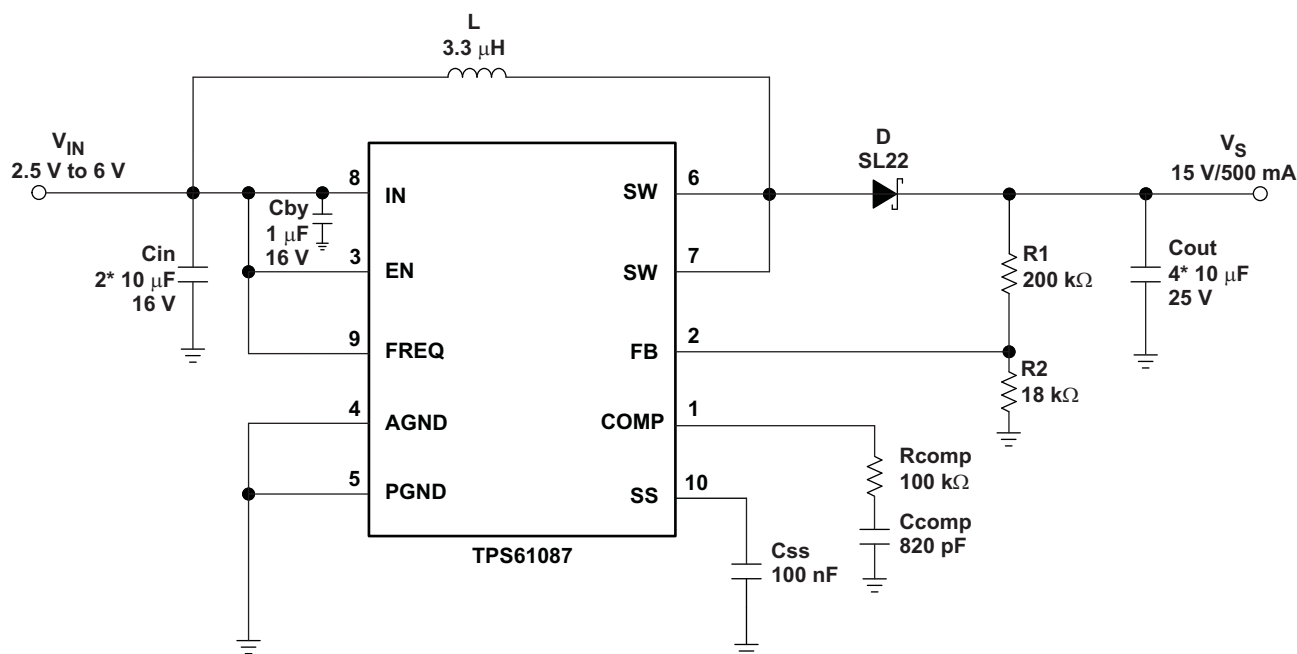

Table of Contents

1 Features	1	7.4 Device Functional Modes.....	10
2 Applications	1	8 Application and Implementation	11
3 Description	1	8.1 Application Information.....	11
4 Revision History	2	8.2 Typical Application	11
5 Pin Configuration and Functions	4	8.3 System Examples	17
6 Specifications	4	9 Power Supply Recommendations	22
6.1 Absolute Maximum Ratings	4	10 Layout	22
6.2 ESD Ratings.....	5	10.1 Layout Guidelines	22
6.3 Recommended Operating Conditions.....	5	10.2 Layout Example	23
6.4 Thermal Information	5	11 Device and Documentation Support	24
6.5 Electrical Characteristics.....	5	11.1 Third-Party Products Disclaimer	24
6.6 Typical Characteristics.....	6	11.2 Trademarks	24
7 Detailed Description	9	11.3 Electrostatic Discharge Caution.....	24
7.1 Overview	9	11.4 Glossary	24
7.2 Functional Block Diagram	9	12 Mechanical, Packaging, and Orderable Information	24
7.3 Feature Description.....	10		

4 Revision History

NOTE: Page numbers for previous revisions may differ from page numbers in the current version.

Changes from Revision D (August 2014) to Revision E Page

- Changed device number from TPS61085 (typo) to TPS61087 (correct) in the Application Information description paragraph. 11
- Changed device number from TPS61085 (typo) to TPS61087 (correct) in the Power Supply Recommendations section. 22

Changes from Revision C (July 2013) to Revision D Page

- Added *ESD Ratings* table, *Feature Description* section, *Device Functional Modes*, *Application and Implementation* section, *Power Supply Recommendations* section, *Layout* section, *Device and Documentation Support* section, and *Mechanical, Packaging, and Orderable Information* section

Changes from Revision B (March 2010) to Revision C Page

- Added V_{IH} Test Condition for EN, $V_{IN} = 2.5\text{ V to }4.3\text{ V}$ 6

Changes from Revision A (June 2008) to Revision B Page

- Added DSC package to PIN ASSIGNMENT
- Deleted Lead temperature from Absolute Maximum Ratings.....
- Changed f_{osc} to f_s in Electrical Characteristics Boost Converter Oscillator Frequency
- Changed $FREQ = high$ to $FREQ = V_{IN}$ in Electrical Characteristics Boost Converter Oscillator Frequency
- Changed $FREQ = low$ to $FREQ = GND$ in Electrical Characteristics Boost Converter Oscillator Frequency
- Added Maximum load current vs. Input voltage graph.....
- Added Maximum load current vs. Input voltage graph.....
- Changed f to f_s and Frequency to Oscillator Frequency in [Figure 6](#)
- Changed f to f_s and Frequency to Oscillator Frequency in [Figure 7](#)
- Changed the text in the Detailed Description.
- Changed "inductor current ripple is below 20%" to " inductor current ripple is below 35%"

-
- Added output capacitor calculation..... 15
-

Changes from Original (May 2008) to Revision A**Page**

-
- Added text to the Detailed Description - following the Block Diagram 9
-

5 Pin Configuration and Functions

DRC (VSON), DSC (WSON) Package
10 Pins, 3 mm × 3 mm × 1 mm
Top View

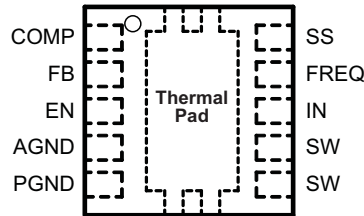

Pin Functions

PIN		I/O	DESCRIPTION
NAME	NO.		
AGND	4, Thermal Pad		Analog ground
COMP	1	I/O	Compensation pin
EN	3	I	Shutdown control input. Connect this pin to logic high level to enable the device
FB	2	I	Feedback pin
FREQ	9	I	Frequency select pin. The power switch operates at 650 kHz if FREQ is connected to GND and at 1.2 MHz if FREQ is connected to IN
IN	8	I	Input supply pin
PGND	5		Power ground
SS	10	O	Soft-start control pin. Connect a capacitor to this pin if soft-start needed. Open = no soft-start
SW	6, 7	I	Switch pin

6 Specifications

6.1 Absolute Maximum Ratings

over operating free-air temperature range (unless otherwise noted)⁽¹⁾

	MIN	MAX	UNIT
Input voltage range IN ⁽²⁾	-0.3	7.0	V
Voltage range on pins EN, FB, SS, FREQ, COMP	-0.3	7.0	V
Voltage on pin SW	-0.3	20	V
Continuous power dissipation	See Thermal Information		
Operating junction temperature range	-40	150	°C
Storage temperature range	-65	150	°C

- (1) Stresses beyond those listed under *Absolute Maximum Ratings* may cause permanent damage to the device. These are stress ratings only, and functional operation of the device at these or any other conditions beyond those indicated under *Recommended Operating Conditions* is not implied. Exposure to absolute-maximum-rated conditions for extended periods may affect device reliability
- (2) All voltage values are with respect to network ground terminal.

6.2 ESD Ratings

		VALUE	UNIT
$V_{(ESD)}$ Electrostatic discharge	Human body model (HBM), per ANSI/ESDA/JEDEC JS-001 ⁽¹⁾	±2000	V
	Charged-device model (CDM), per JEDEC specification JESD22-C101 ⁽²⁾	±500	
	Machine model (MM)	±200	

- (1) JEDEC document JEP155 states that 500-V HBM allows safe manufacturing with a standard ESD control process. Manufacturing with less than 500-V HBM is possible with the necessary precautions. Pins listed as ±2000 V may actually have higher performance.
- (2) JEDEC document JEP157 states that 250-V CDM allows safe manufacturing with a standard ESD control process. Manufacturing with less than 250-V CDM is possible with the necessary precautions. Pins listed as ±500 V may actually have higher performance.

6.3 Recommended Operating Conditions

		MIN	NOM	MAX	UNIT
V_{IN}	Input voltage range	2.5		6	V
V_S	Boost output voltage range	$V_{IN} + 0.5$		18.5	V
T_A	Operating free-air temperature	−40		85	°C
T_J	Operating junction temperature	−40		125	°C

6.4 Thermal Information

THERMAL METRIC ⁽¹⁾	TPS61087		UNIT	
	DRC	DSC		
	10 PINS	10 PINS		
$R_{\theta JA}$	Junction-to-ambient thermal resistance	54.7	55.3	°C/W
$R_{\theta JC(top)}$	Junction-to-case (top) thermal resistance	67.2	84.8	°C/W
$R_{\theta JB}$	Junction-to-board thermal resistance	29.6	29.7	°C/W
Ψ_{JT}	Junction-to-top characterization parameter	2.3	5.4	°C/W
Ψ_{JB}	Junction-to-board characterization parameter	29.8	29.8	°C/W
$R_{\theta JC(bot)}$	Junction-to-case (bottom) thermal resistance	15.6	10.9	°C/W

- (1) For more information about traditional and new thermal metrics, see the *IC Package Thermal Metrics* application report, [SPRA953](#).

6.5 Electrical Characteristics

$V_{IN} = 5\text{ V}$, $EN = V_{IN}$, $V_S = 15\text{ V}$, $T_A = -40^\circ\text{C}$ to 85°C , typical values are at $T_A = 25^\circ\text{C}$ (unless otherwise noted)

PARAMETER	TEST CONDITIONS	MIN	TYP	MAX	UNIT	
SUPPLY						
V_{IN}	Input voltage range	2.5		6	V	
I_Q	Operating quiescent current into IN	Device not switching, $V_{FB} = 1.3\text{ V}$		75	100	μA
I_{SDVIN}	Shutdown current into IN	EN = GND			1	μA
V_{UVLO}	Undervoltage lockout threshold	V_{IN} falling			2.4	V
		V_{IN} rising			2.5	V
T_{SD}	Thermal shutdown	Temperature rising		150		°C
T_{SDHYS}	Thermal shutdown hysteresis			14		°C

Electrical Characteristics (continued)

 $V_{IN} = 5\text{ V}$, $EN = V_{IN}$, $V_S = 15\text{ V}$, $T_A = -40^\circ\text{C}$ to 85°C , typical values are at $T_A = 25^\circ\text{C}$ (unless otherwise noted)

PARAMETER		TEST CONDITIONS	MIN	TYP	MAX	UNIT
LOGIC SIGNALS EN, FREQ						
V_{IH}	High-level input voltage	$V_{IN} = 2.5\text{ V to }6.0\text{ V}$	2			V
		Valid only for EN, $V_{IN} = 2.5\text{ V to }4.3\text{ V}$	1.6			
V_{IL}	Low-level input voltage	$V_{IN} = 2.5\text{ V to }6.0\text{ V}$	0.5			V
I_{INLEAK}	Input leakage current	EN = FREQ = GND	0.1			μA
BOOST CONVERTER						
V_S	Boost output voltage		$V_{IN} + 0.5$	18.5		V
V_{FB}	Feedback regulation voltage		1.230	1.238	1.246	V
gm	Transconductance error amplifier		107			$\mu\text{A/V}$
I_{FB}	Feedback input bias current	$V_{FB} = 1.238\text{ V}$	0.1			μA
$r_{DS(on)}$	N-channel MOSFET on-resistance	$V_{IN} = V_{GS} = 5\text{ V}$, $I_{SW} = \text{current limit}$	0.13		0.18	Ω
		$V_{IN} = V_{GS} = 3\text{ V}$, $I_{SW} = \text{current limit}$	0.16		0.23	
I_{SWLEAK}	SW leakage current	EN = GND, $V_{SW} = V_{IN} = 6.0\text{ V}$	2			μA
I_{LIM}	N-Channel MOSFET current limit		3.2	4.0	4.8	A
I_{SS}	Soft-start current	$V_{SS} = 1.238\text{ V}$	7	10	13	μA
f_S	Oscillator frequency	FREQ = V_{IN}	0.9	1.2	1.5	MHz
		FREQ = GND	480	650	820	kHz
	Line regulation	$V_{IN} = 2.5\text{ V to }6.0\text{ V}$, $I_{OUT} = 10\text{ mA}$	0.0002			%/V
	Load regulation	$V_{IN} = 5.0\text{ V}$, $I_{OUT} = 1\text{ mA to }1\text{ A}$	0.11			%/A

6.6 Typical Characteristics

The typical characteristics are measured with the inductors 7447789003 3.3 μH (high frequency) or 74454068 6.8 μH (low frequency) from Würth and the rectifier diode SL22.

Table 1. Table of Graphs

			FIGURE
$I_{OUT(max)}$	Maximum load current	vs. Input voltage at High frequency (1.2 MHz)	Figure 1
$I_{OUT(max)}$	Maximum load current	vs. Input voltage at Low frequency (650 kHz)	Figure 2
η	Efficiency	vs. Load current, $V_S = 15\text{ V}$, $V_{IN} = 5\text{ V}$	Figure 3
η	Efficiency	vs. Load current, $V_S = 9\text{ V}$, $V_{IN} = 3.3\text{ V}$	Figure 4
	Supply current	vs. Supply voltage	Figure 5
	Oscillator frequency	vs. Load current	Figure 6
	Oscillator frequency	vs. Supply voltage	Figure 7

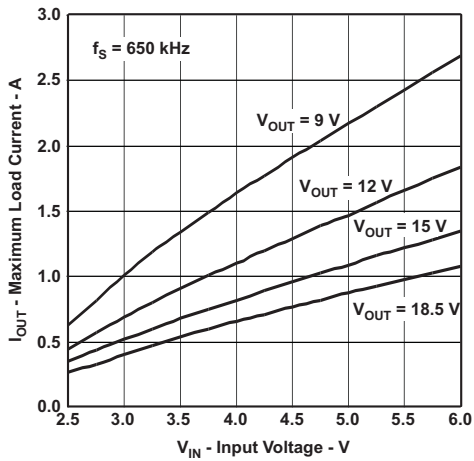

Figure 1. Maximum Load Current vs Input Voltage

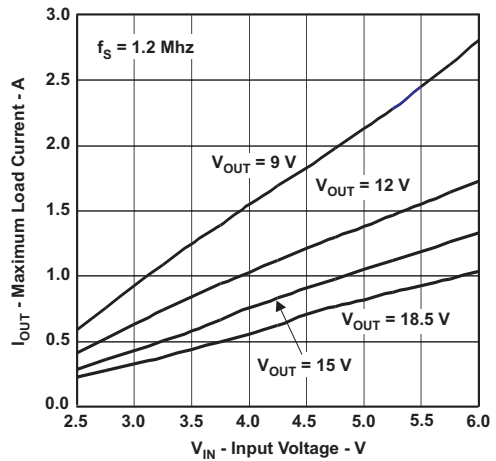

Figure 2. Maximum Load Current vs Input Voltage

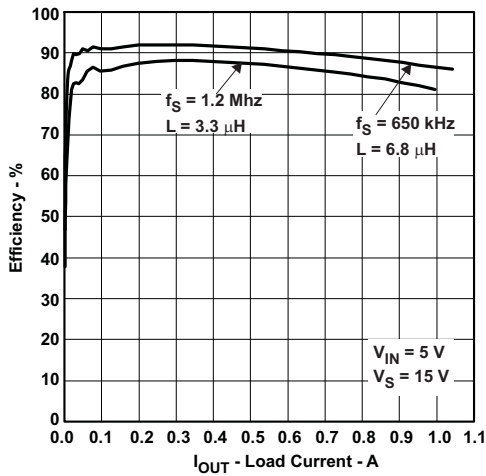

Figure 3. Efficiency vs Load Current

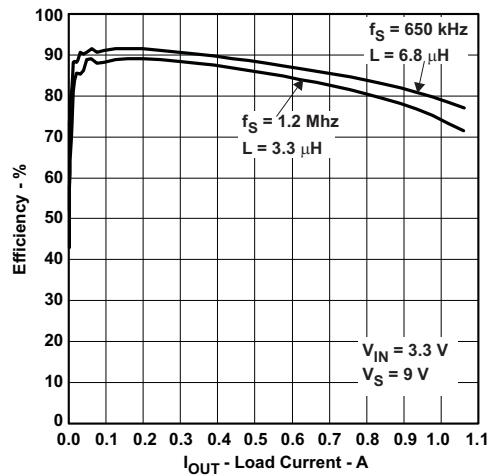

Figure 4. Efficiency vs Load Current

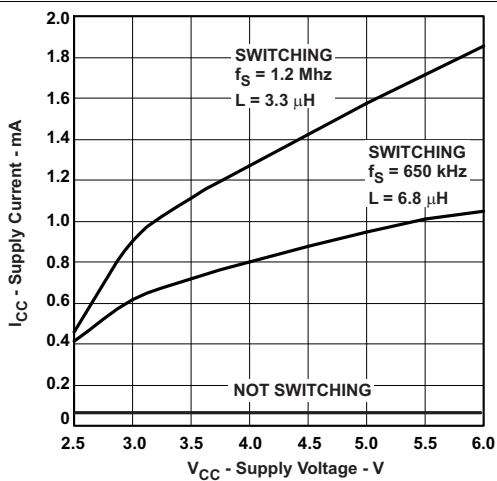

Figure 5. Supply Current vs Supply Voltage

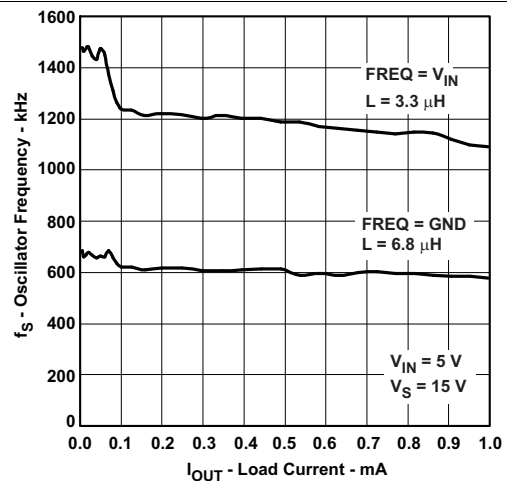

Figure 6. Oscillator Frequency vs Load Current

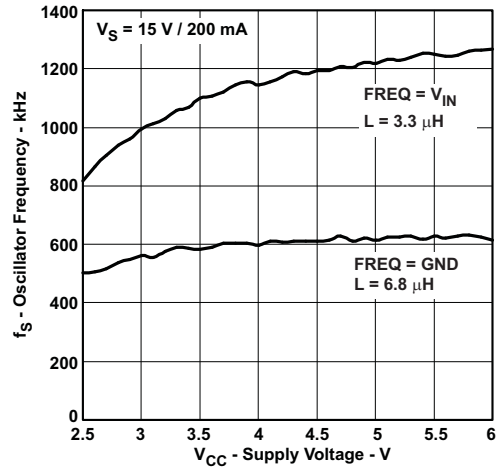

Figure 7. Oscillator Frequency vs Supply Voltage

7 Detailed Description

7.1 Overview

The boost converter is designed for output voltages of up to 18.5 V with a switch peak current limit of 3.2 A minimum. The device, which operates in a current mode scheme with quasi-constant frequency, is externally compensated for maximum flexibility and stability. The switching frequency is selectable between 650 kHz and 1.2 MHz, and the minimum input voltage is 2.5 V. To limit the inrush current at start-up, a soft-start pin is available.

The novel topology of the TPS60187 boost converter uses adaptive off-time to provide superior load and line transient responses. This topology also operates over a wider range of applications than conventional converters.

The selectable switching frequency offers the possibility to optimize the design either for the use of small-sized components (1.2 MHz) or for higher system efficiency (650 kHz). However, the frequency changes slightly because the voltage drop across the $r_{DS(on)}$ has some influence on the current and voltage measurement and thus on the on-time (the off-time remains constant).

The converter operates in continuous conduction mode (CCM) as soon as the input current increases above half the ripple current in the inductor, for lower load currents it switches into discontinuous conduction mode (DCM). If the load is further reduced, the part starts to skip pulses to maintain the output voltage.

7.2 Functional Block Diagram

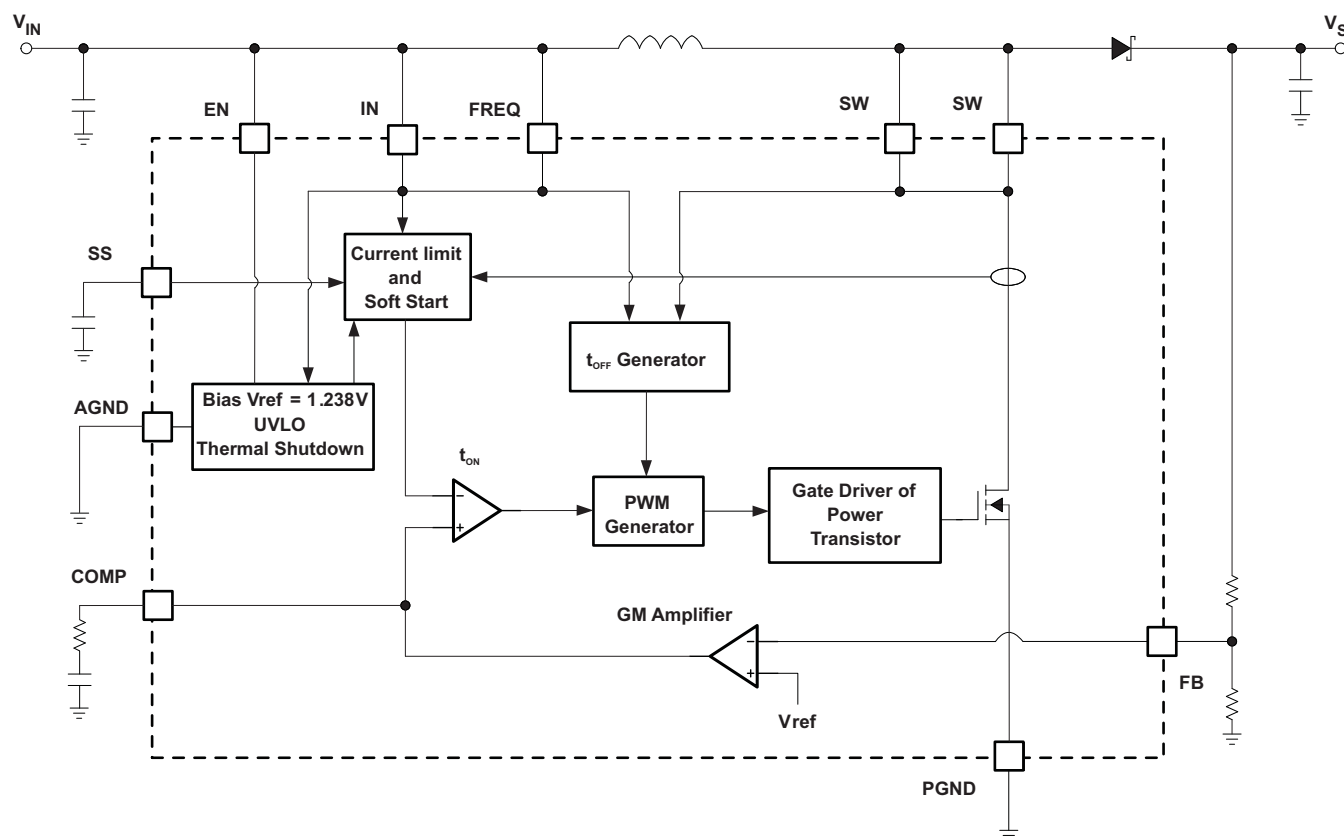

7.3 Feature Description

7.3.1 Soft-Start

The boost converter has an adjustable soft-start to prevent high inrush current during start-up. To minimize the inrush current during start-up an external capacitor, connected to the soft-start pin SS and charged with a constant current, is used to slowly ramp up the internal current limit of the boost converter. When the EN pin is pulled high, the soft-start capacitor C_{SS} is immediately charged to 0.3 V. The capacitor is then charged at a constant current of 10 μ A typically until the output of the boost converter V_S has reached its Power Good threshold (roughly 98% of V_S nominal value). During this time, the SS voltage directly controls the peak inductor current, starting with 0 A at $V_{SS} = 0.3$ V up to the full current limit at $V_{SS} = 800$ mV. The maximum load current is available after the soft-start is completed. The larger the capacitor the slower the ramp of the current limit and the longer the soft-start time. A 100-nF capacitor is usually sufficient for most of the applications. When the EN pin is pulled low, the soft-start capacitor is discharged to ground.

7.3.2 Frequency Select Pin (FREQ)

The frequency select pin FREQ allows to set the switching frequency of the device to 650 kHz (FREQ = low) or 1.2 MHz (FREQ = high). Higher switching frequency improves load transient response but reduces slightly the efficiency. The other benefits of higher switching frequency are a lower output ripple voltage. The use of a 1.2-MHz switching frequency is recommended unless light load efficiency is a major concern.

7.3.3 Undervoltage Lockout (UVLO)

To avoid mis-operation of the device at low input voltages an undervoltage lockout is included that disables the device, if the input voltage falls below 2.4 V.

7.3.4 Thermal Shutdown

A thermal shutdown is implemented to prevent damages due to excessive heat and power dissipation. Typically the thermal shutdown happens at a junction temperature of 150°C. When the thermal shutdown is triggered the device stops switching until the junction temperature falls below typically 136°C. Then the device starts switching again.

7.3.5 Overvoltage Prevention

If overvoltage is detected on the FB pin (typically 3% above the nominal value of 1.238 V) the part stops switching immediately until the voltage on this pin drops to its nominal value. This prevents overvoltage on the output and secures the circuits connected to the output from excessive overvoltage.

7.4 Device Functional Modes

The converter operates in continuous conduction mode (CCM) as soon as the input current increases above half the ripple current in the inductor, for lower load currents it switches into discontinuous conduction mode (DCM). If the load is further reduced, the part starts to skip pulses to maintain the output voltage.

8 Application and Implementation

NOTE

Information in the following applications sections is not part of the TI component specification, and TI does not warrant its accuracy or completeness. TI's customers are responsible for determining suitability of components for their purposes. Customers should validate and test their design implementation to confirm system functionality.

8.1 Application Information

The TPS61087 is designed for output voltages up to 18.5 V with a switch peak current limit of 2.0-A minimum. The device, which operates in a current mode scheme with quasi-constant frequency, is externally compensated for maximum flexibility and stability. The switching frequency is selectable between 650 kHz and 1.2 MHz, and the input voltage range is 2.3 V to 6.0 V. To control the inrush current at start-up a soft-start pin is available. The following section provides a step-by-step design approach for configuring the TPS61087 as a voltage regulating boost converter.

8.2 Typical Application

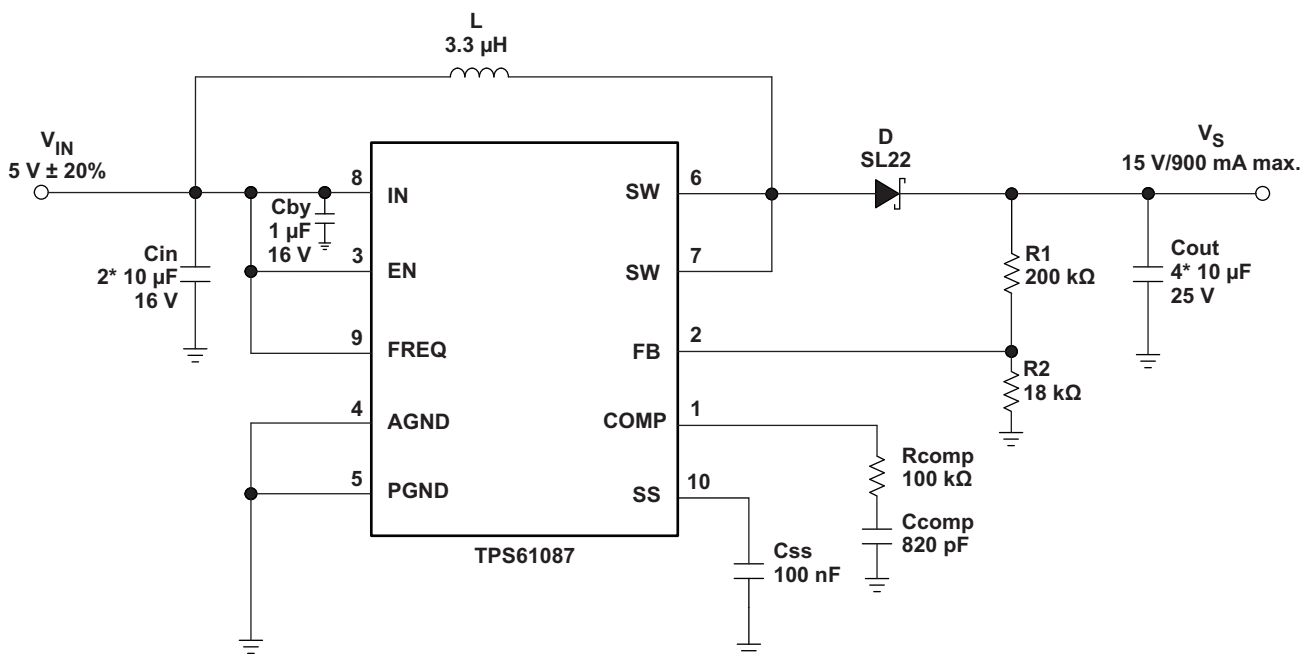

Figure 8. Typical Application, 5 V to 15 V ($f_s = 1.2$ MHz)

8.2.1 Design Requirements

Table 2. TPS61087 15-V Output Design Requirements

PARAMETERS	VALUES
Input Voltage	5 V \pm 20%
Output Voltage	15 V
Output Current	900 mA
Switching Frequency	1.2 MHz

8.2.2 Detailed Design Procedure

The first step in the design procedure is to verify that the maximum possible output current of the boost converter supports the specific application requirements. A simple approach is to estimate the converter efficiency, by taking the efficiency numbers from the provided efficiency curves or to use a worst case assumption for the expected efficiency, for example, 90%.

1. Duty cycle, D :

$$D = 1 - \frac{V_{IN} \cdot \eta}{V_S} \quad (1)$$

2. Maximum output current, $I_{out(max)}$:

$$I_{out(max)} = \left(I_{LIM(min)} - \frac{\Delta I_L}{2} \right) \cdot (1 - D) \quad (2)$$

3. Peak switch current in application, I_{swpeak} :

$$I_{swpeak} = \frac{\Delta I_L}{2} + \frac{I_{out}}{1 - D} \quad (3)$$

with the inductor peak-to-peak ripple current, ΔI_L

$$\Delta I_L = \frac{V_{IN} \cdot D}{f_S \cdot L} \quad (4)$$

and

V_{IN}	Minimum input voltage
V_S	Output voltage
$I_{LIM(min)}$	Converter switch current limit (minimum switch current limit = 3.2 A)
f_S	Converter switching frequency (typically 1.2 MHz or 650 kHz)
L	Selected inductor value
η	Estimated converter efficiency (use the number from the efficiency plots or 90% as an estimation)

The peak switch current is the steady state peak switch current that the integrated switch, inductor and external Schottky diode has to be able to handle. The calculation must be done for the minimum input voltage where the peak switch current is the highest.

8.2.2.1 Inductor Selection

The TPS61087 is designed to work with a wide range of inductors. The main parameter for the inductor selection is the saturation current of the inductor which should be higher than the peak switch current as calculated in the [Detailed Design Procedure](#) section with additional margin to cover for heavy load transients. An alternative, more conservative, is to choose an inductor with a saturation current at least as high as the maximum switch current limit of 4.8 A. The other important parameter is the inductor DC resistance. Usually the lower the DC resistance the higher the efficiency. It is important to note that the inductor DC resistance is not the only parameter determining the efficiency. Especially for a boost converter where the inductor is the energy storage element, the type and core material of the inductor influences the efficiency as well. At high switching frequencies of 1.2 MHz inductor core losses, proximity effects and skin effects become more important. Usually an inductor with a larger form factor gives higher efficiency. The efficiency difference between different inductors can vary between 2% to 10%. For the TPS61087, inductor values between 3 μH and 6 μH are a good choice with a switching frequency of 1.2 MHz, typically 3.3 μH . At 650 kHz TI recommends inductors between 6 μH and 13 μH , typically 6.8 μH . Possible inductors are shown in [Table 3](#).

Typically, TI recommends an inductor current ripple below 35% of the average inductor current. Therefore, the following equation can be used to calculate the inductor value, L :

$$L = \left(\frac{V_{IN}}{V_S} \right)^2 \cdot \left(\frac{V_S - V_{IN}}{I_{out} \cdot f_S} \right) \cdot \left(\frac{\eta}{0.35} \right) \quad (5)$$

with

V_{IN}	Minimum input voltage
V_S	Output voltage
I_{out}	Maximum output current in the application
f_S	Converter switching frequency (typically 1.2 MHz or 650 kHz)
η	Estimated converter efficiency (use the number from the efficiency plots or 90% as an estimation)

Table 3. Inductor Selection

L (μ H)	SUPPLIER	COMPONENT CODE	SIZE (LxWxH mm)	DCR TYP (m Ω)	I _{sat} (A)
1.2 MHz					
4.2	Sumida	CDRH5D28	5.7 × 5.7 × 3	23	2.2
4.7	Würth Elektronik	7447785004	5.9 × 6.2 × 3.3	60	2.5
5	Coilcraft	MSS7341	7.3 × 7.3 × 4.1	24	2.9
5	Sumida	CDRH6D28	7 × 7 × 3	23	2.4
4.6	Sumida	CDR7D28	7.6 × 7.6 × 3	38	3.15
4.7	Würth Elektronik	7447789004	7.3 × 7.3 × 3.2	33	3.9
3.3	Würth Elektronik	7447789003	7.3 × 7.3 × 3.2	30	4.2
650 kHz					
10	Würth Elektronik	744778910	7.3 × 7.3 × 3.2	51	2.2
10	Sumida	CDRH8D28	8.3 × 8.3 × 3	36	2.7
6.8	Sumida	CDRH6D26HPNP	7 × 7 × 2.8	52	2.9
6.2	Sumida	CDRH8D58	8.3 × 8.3 × 6	25	3.3
10	Coilcraft	DS3316P	12.95 × 9.40 × 5.08	80	3.5
10	Sumida	CDRH8D43	8.3 × 8.3 × 4.5	29	4
6.8	Würth Elektronik	74454068	12.7 × 10 × 4.9	55	4.1

8.2.2.2 Rectifier Diode Selection

To achieve high efficiency a Schottky type should be used for the rectifier diode. The reverse voltage rating should be higher than the maximum output voltage of the converter. The averaged rectified forward current I_{avg} , the Schottky diode needs to be rated for, is equal to the output current I_{out} :

$$I_{avg} = I_{out} \quad (6)$$

Usually a Schottky diode with 2-A maximum average rectified forward current rating is sufficient for most applications. The Schottky rectifier can be selected with lower forward current capability depending on the output current I_{out} but has to be able to dissipate the power. The dissipated power, P_D , is the average rectified forward current times the diode forward voltage, $V_{forward}$.

$$P_D = I_{avg} \cdot V_{forward} \quad (7)$$

Typically, the diode should be able to dissipate around 500 mW depending on the load current and forward voltage.

Table 4. Rectifier Diode Selection

CURRENT RATING I_{avg}	V_r	$V_{forward} I_{avg}$	SUPPLIER	COMPONENT CODE
2 A	20 V	0.44 V / 2 A	Vishay Semiconductor	SL22
2 A	20 V	0.5 V / 2 A	Fairchild Semiconductor	SS22

8.2.2.3 Setting the Output Voltage

The output voltage is set by an external resistor divider. Typically, a minimum current of 50 μ A flowing through the feedback divider gives good accuracy and noise covering. A standard low-side resistor of 18 k Ω is typically selected. The resistors are then calculated as:

$$R2 = \frac{V_{FB}}{70\mu A} \approx 18k\Omega \quad R1 = R2 \cdot \left(\frac{V_s}{V_{FB}} - 1 \right)$$

$$V_{FB} = 1.238V$$

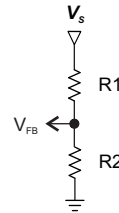

(8)

8.2.2.4 Compensation (COMP)

The regulator loop can be compensated by adjusting the external components connected to the COMP pin. The COMP pin is the output of the internal transconductance error amplifier.

Standard values of $R_{COMP} = 16\text{ k}\Omega$ and $C_{COMP} = 2.7\text{ nF}$ will work for the majority of the applications.

See [Table 5](#) for dedicated compensation networks giving an improved load transient response. The following equations can be used to calculate R_{COMP} and C_{COMP} :

$$R_{COMP} = \frac{110 \cdot V_{IN} \cdot V_s \cdot C_{out}}{L \cdot I_{out}} \quad C_{COMP} = \frac{V_s \cdot C_{out}}{7.5 \cdot I_{out} \cdot R_{COMP}}$$

with

- V_{IN} Minimum input voltage
- V_s Output voltage
- C_{out} Output capacitance
- L Inductor value, for example, 3.3 μ H or 6.8 μ H
- I_{out} Maximum output current in the application

Make sure that $R_{COMP} < 120\text{ k}\Omega$ and $C_{COMP} > 820\text{ pF}$, independent of the results of the above formulas.

Table 5. Recommended Compensation Network Values at High/Low Frequency

FREQUENCY	L	V_s	$V_{IN} \pm 20\%$	R_{COMP}	C_{COMP}
High (1.2 MHz)	3.3 μ H	15 V	5 V	100 k Ω	820 pF
			3.3 V	91 k Ω	1.2 nF
		12 V	5 V	68 k Ω	820 pF
			3.3 V	68 k Ω	1.2 nF
		9 V	5 V	39 k Ω	820 pF
			3.3 V	39 k Ω	1.2 nF
Low (650 kHz)	6.8 μ H	15 V	5 V	51 k Ω	1.5 nF
			3.3 V	47 k Ω	2.7 nF
		12 V	5 V	33 k Ω	1.5 nF
			3.3 V	33 k Ω	2.7 nF
		9 V	5 V	18 k Ω	1.5 nF
			3.3 V	18 k Ω	2.7 nF

Table 5 gives conservative R_{COMP} and C_{COMP} values for certain inductors, input and output voltages providing a very stable system. For a faster response time, a higher R_{COMP} value can be used to enlarge the bandwidth, as well as a slightly lower value of C_{COMP} to keep enough phase margin. These adjustments should be performed in parallel with the load transient response monitoring of TPS61087.

8.2.2.5 Input Capacitor Selection

For good input voltage filtering low ESR ceramic capacitors are recommended. TPS61087 has an analog input IN. Therefore, a 1- μ F bypass is highly recommended as close as possible to the IC from IN to GND.

Two 10- μ F (or one 22- μ F) ceramic input capacitors are sufficient for most of the applications. For better input voltage filtering this value can be increased. See Table 6 and typical applications for input capacitor recommendation.

8.2.2.6 Output Capacitor Selection

For best output voltage filtering a low ESR output capacitor like ceramic capacitor is recommended. Four 10- μ F ceramic output capacitors (or two-22 μ F) work for most of the applications. Higher capacitor values can be used to improve the load transient response. See Table 6 for the selection of the output capacitor.

Table 6. Rectifier Input and Output Capacitor Selection

	CAPACITOR/SIZE	VOLTAGE RATING	SUPPLIER	COMPONENT CODE
C_{IN}	22 μ F/1206	16 V	Taiyo Yuden	EMK316 BJ 226ML
IN bypass	1 μ F/0603	16 V	Taiyo Yuden	EMK107 BJ 105KA
C_{OUT}	10 μ F/1206	25 V	Taiyo Yuden	TMK316 BJ 106KL

To calculate the output voltage ripple, the following equation can be used:

$$\Delta V_C = \frac{V_S - V_{IN}}{V_S \cdot f_S} \cdot \frac{I_{out}}{C_{out}} \quad \Delta V_{C_ESR} = I_{L(peak)} \cdot R_{C_ESR} \quad (10)$$

with

ΔV_C	Output voltage ripple dependent on output capacitance, output current and switching frequency
V_S	Output voltage
V_{IN}	Minimum input voltage of boost converter
f_S	Converter switching frequency (typically 1.2 MHz or 650 kHz)
I_{out}	Output capacitance
ΔV_{C_ESR}	Output voltage ripple due to output capacitors ESR (equivalent series resistance)
I_{SWPEAK}	Inductor peak switch current in the application
R_{C_ESR}	Output capacitors equivalent series resistance (ESR)

ΔV_{C_ESR} can be neglected in many cases since ceramic capacitors provide low ESR.

8.2.3 Application Curves

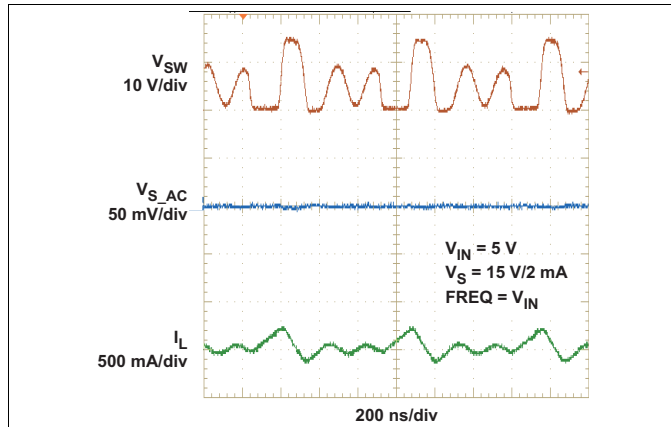

Figure 9. PWM Switching Discontinuous Conduction Mode

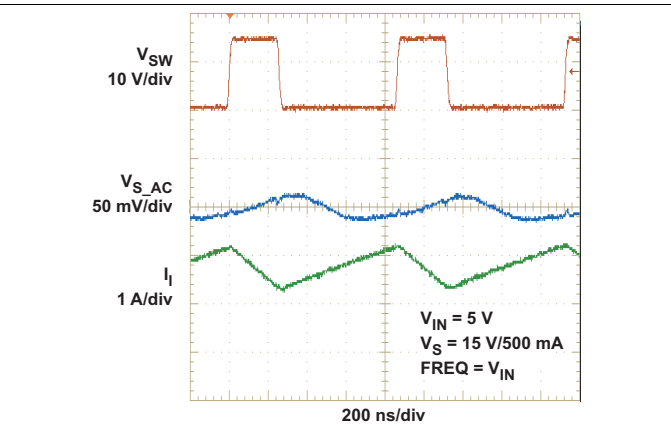

Figure 10. PWM Switching Continuous Conduction Mode

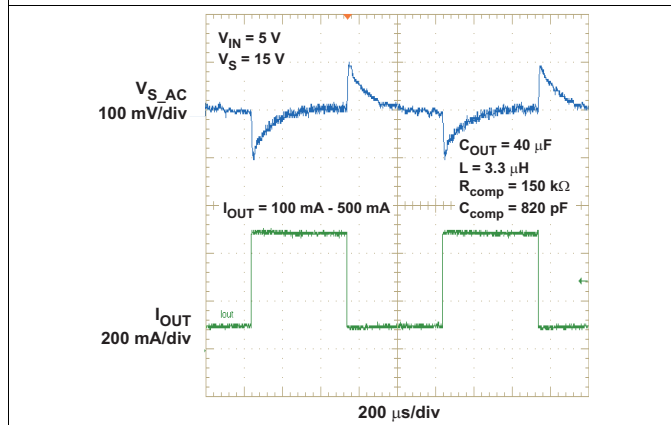

Figure 11. Load Transient Response High Frequency (1.2 MHz)

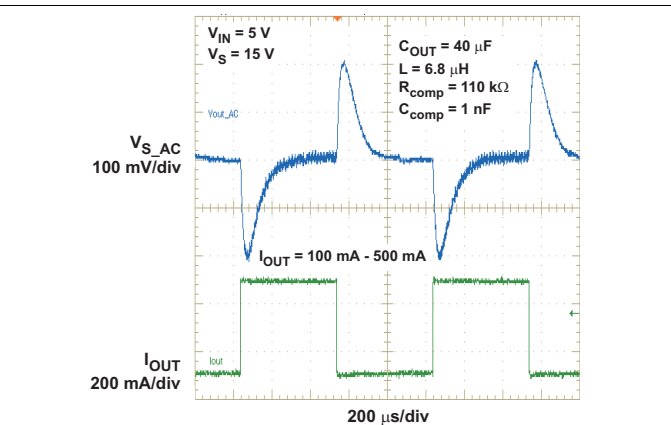

Figure 12. Load Transient Response Low Frequency (650 kHz)

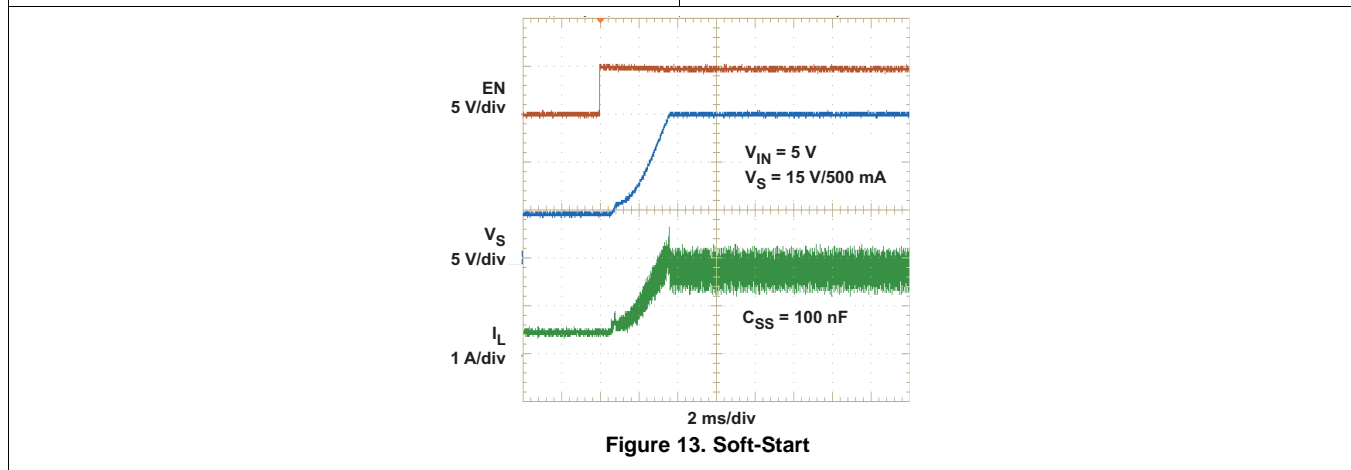

Figure 13. Soft-Start

8.3 System Examples

8.3.1 General Boost Application Circuits

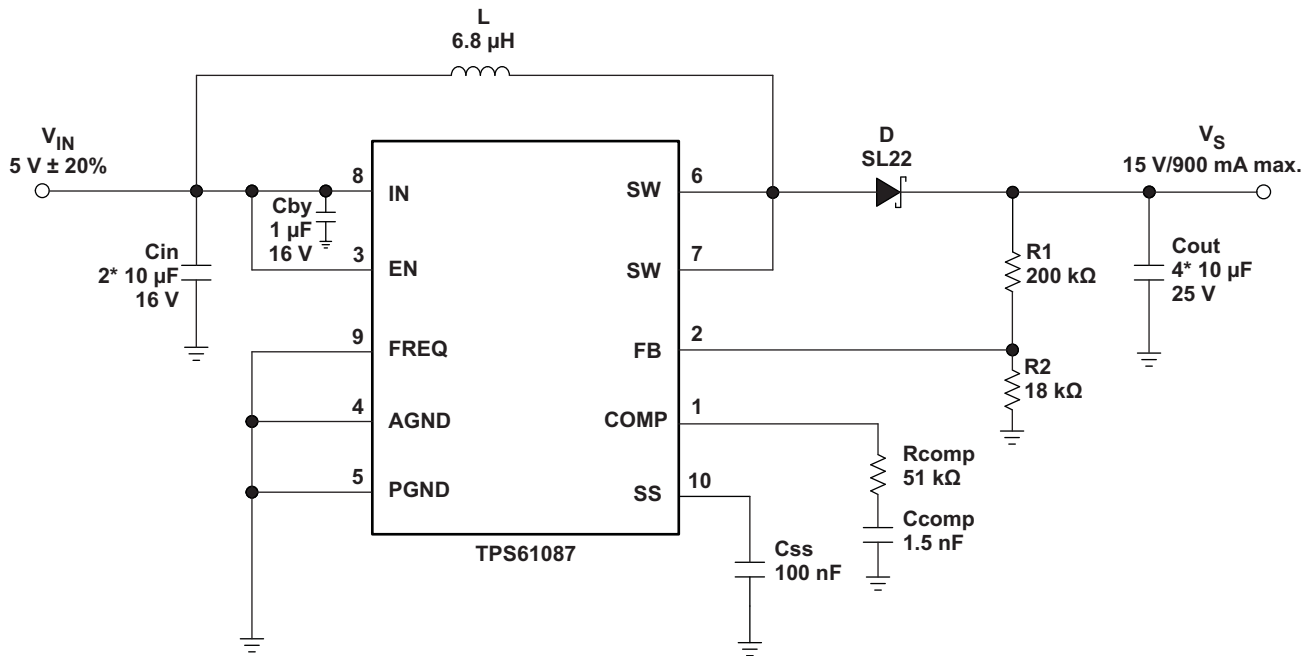

Figure 14. Typical Application, 5 V to 15 V ($f_s = 650\text{ kHz}$)

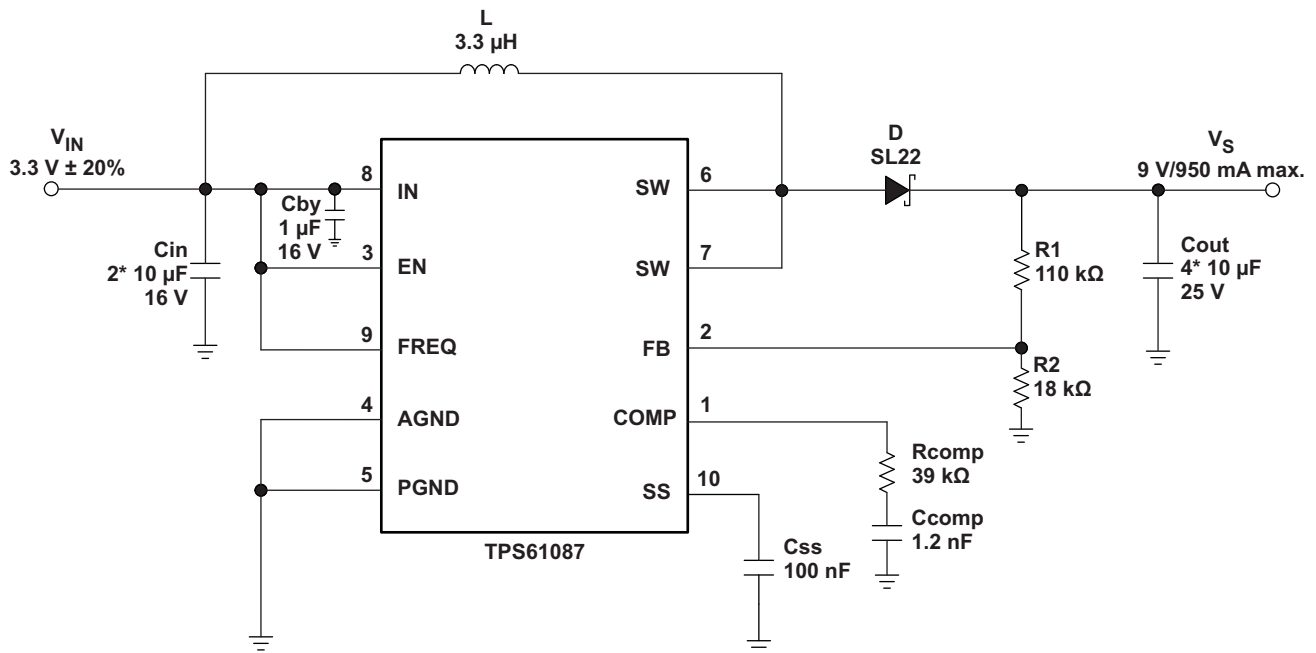
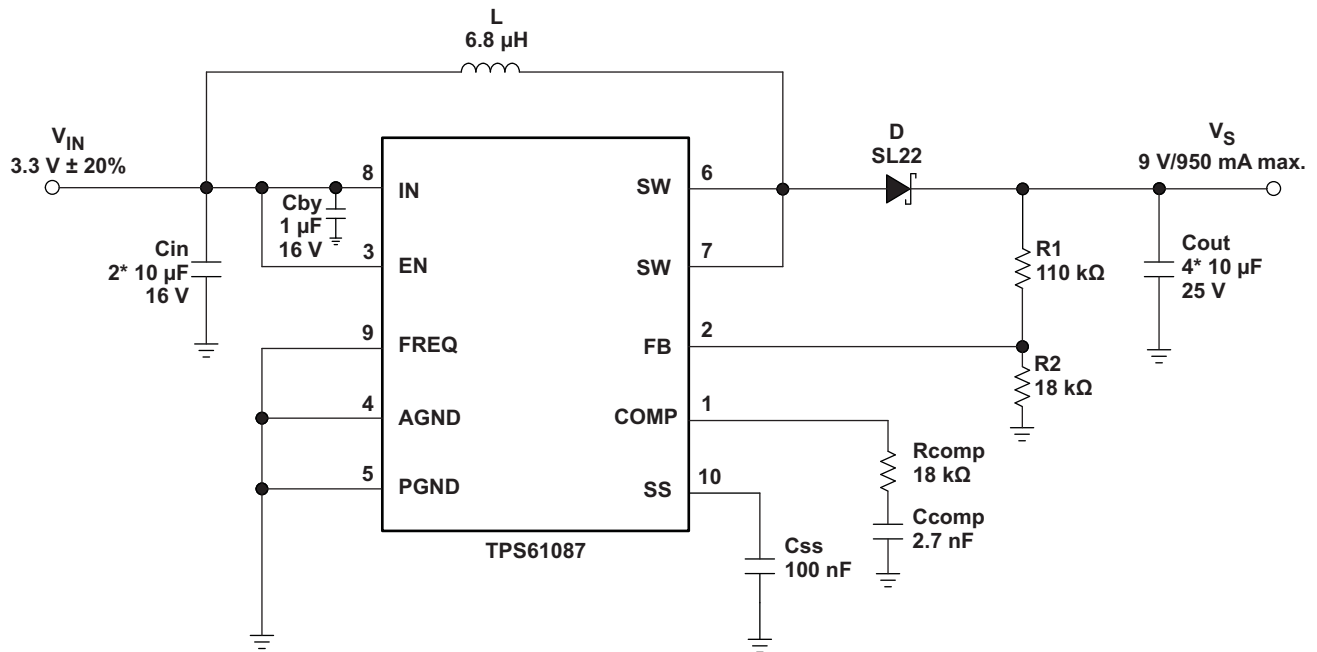
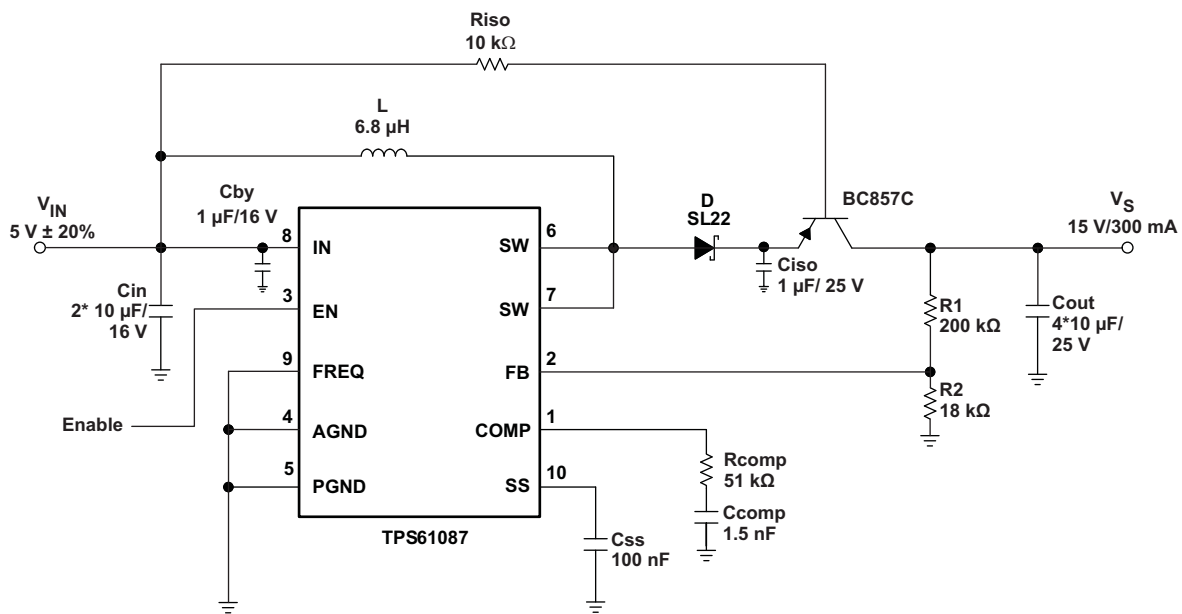

Figure 15. Typical Application, 3.3 V to 9 V ($f_s = 1.2\text{ MHz}$)

System Examples (continued)

Figure 16. Typical Application, 3.3 V to 9 V ($f_s = 650\text{ kHz}$)

Figure 17. Typical Application With External Load Disconnect Switch

System Examples (continued)

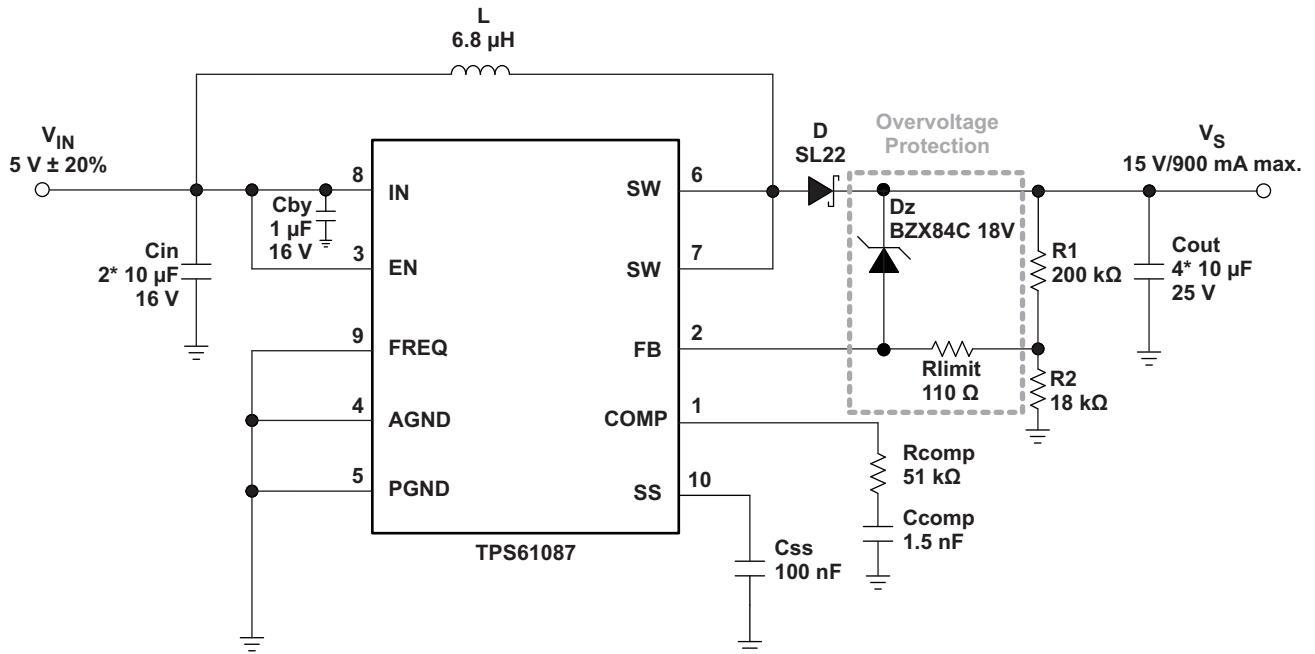

Figure 18. Typical Application, 5 V to 15 V ($f_s = 1.2\text{ MHz}$) With Overvoltage Protection

System Examples (continued)

8.3.2 TFT LCD Application

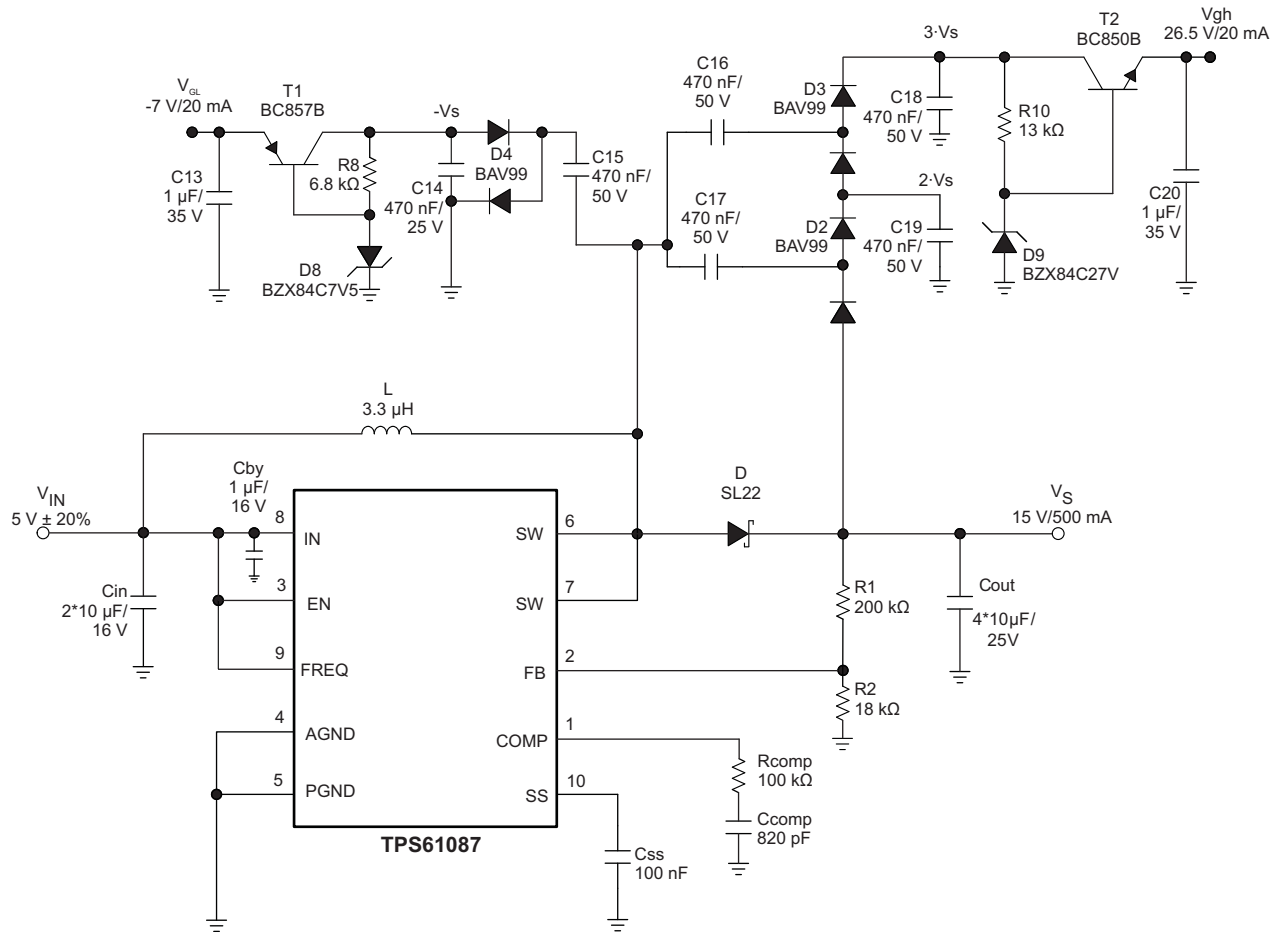

Figure 19. Typical Application 5 V to 15 V ($f_s = 1.2 MHz$) for TFT LCD With External Charge Pumps (V_{GH}, V_{GL})

System Examples (continued)

8.3.3 White LED Applications

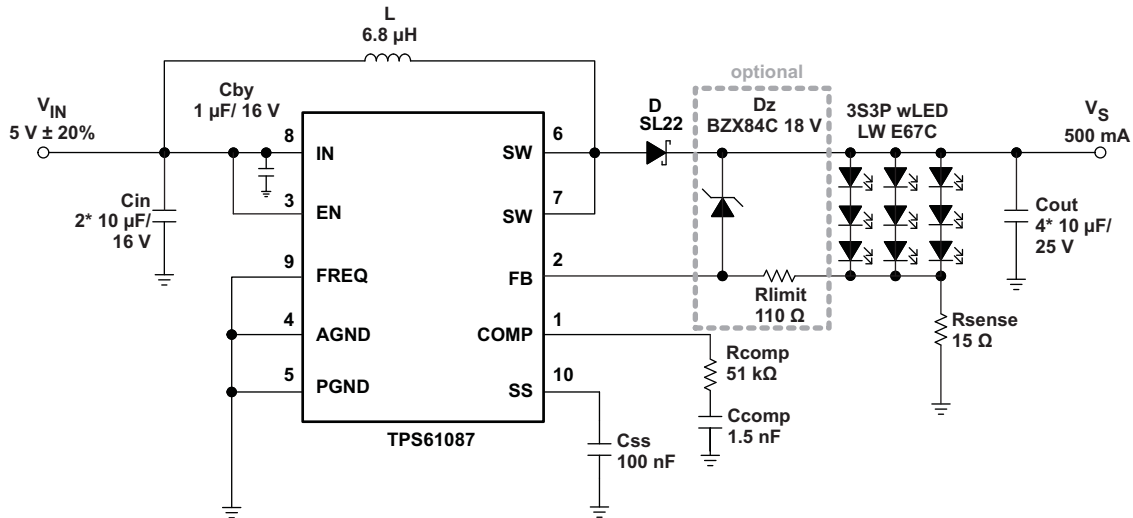

Figure 20. Simple Application (5 V Input Voltage) ($f_s = 650$ kHz) for wLED Supply (3S3P) (With Optional Clamping Zener Diode)

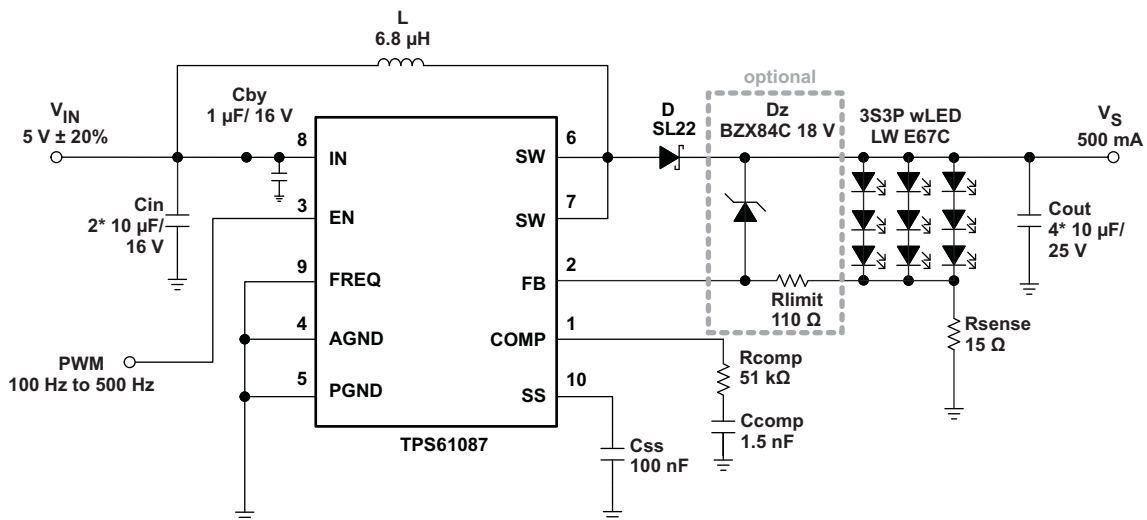

Figure 21. Simple Application (5 V Input Voltage) ($f_s = 650$ kHz) for wLED Supply (3S3P) With Adjustable Brightness Control Using a PWM Signal on the Enable Pin (With Optional Clamping Zener Diode)

System Examples (continued)

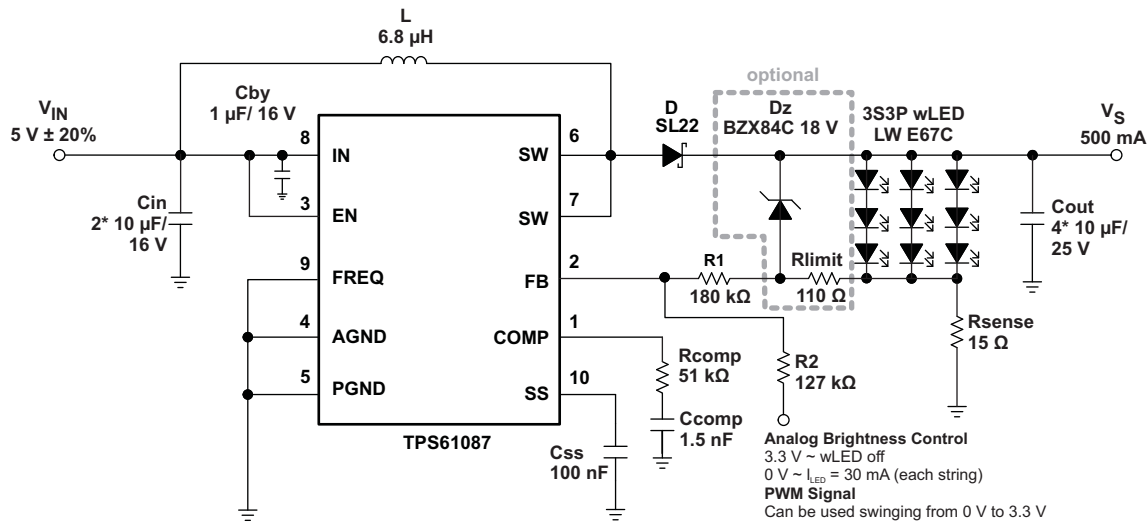

Figure 22. Simple Application (5 V Input Voltage) ($f_s = 650$ kHz) for wLED Supply (3S3P) With Adjustable Brightness Control Using an Analog Signal on the Feedback Pin (With Optional Clamping Zener Diode)

9 Power Supply Recommendations

The TPS61087 is designed to operate from an input voltage supply range from 2.3 V to 6.0 V. The power supply to the TPS61087 must have a current rating according to the supply voltage, output voltage, and output current of the TPS61087.

10 Layout

10.1 Layout Guidelines

For all switching power supplies, the layout is an important step in the design, especially at high peak currents and high switching frequencies. If the layout is not carefully done, the regulator could show stability problems as well as EMI problems. Therefore, use wide and short traces for the main current path and for the power ground tracks. The input capacitor, output capacitor, and the inductor should be placed as close as possible to the IC. Use a common ground node for power ground and a different one for control ground to minimize the effects of ground noise. Connect these ground nodes at the GND terminal of the IC. The most critical current path for all boost converters is from the switching FET, through the rectifier diode, then the output capacitors, and back to ground of the switching FET. Therefore, the output capacitors and their traces should be placed on the same board layer as the IC and as close as possible between the SW pin and the GND terminal of the IC..

10.2 Layout Example

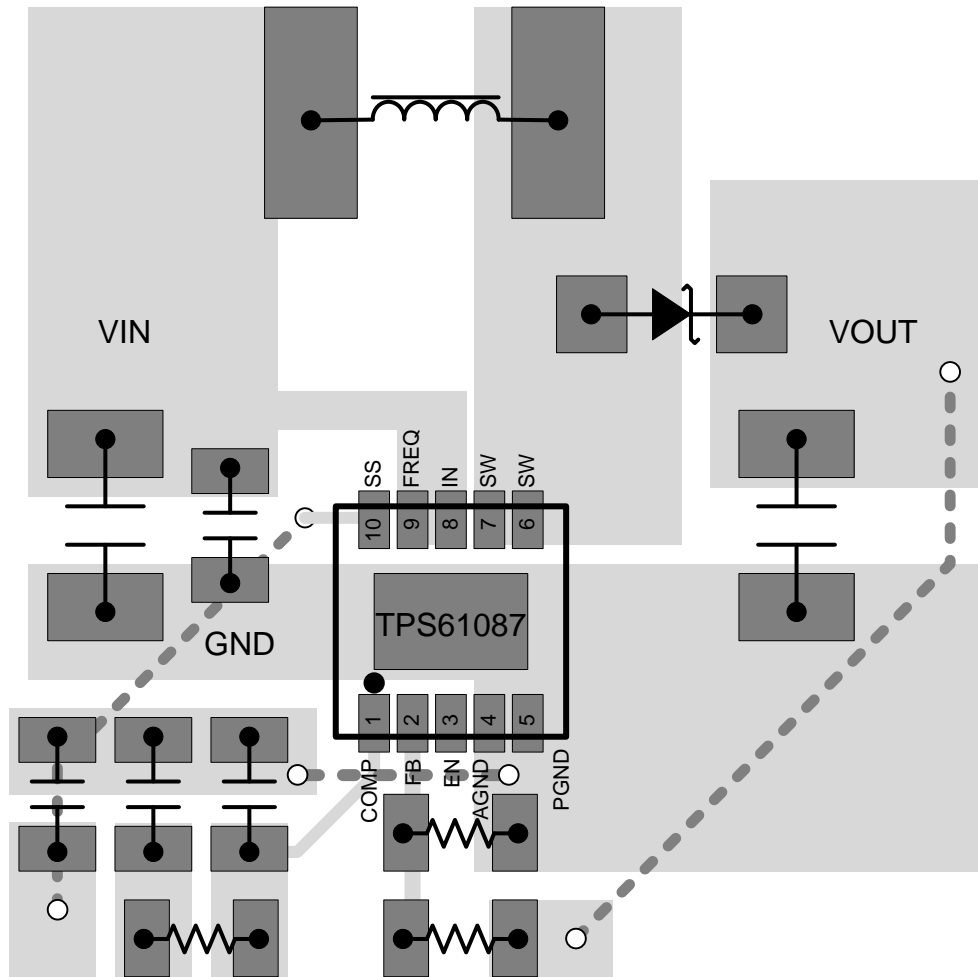

Figure 23. TPS61087 Layout Example

11 Device and Documentation Support

11.1 Third-Party Products Disclaimer

TI'S PUBLICATION OF INFORMATION REGARDING THIRD-PARTY PRODUCTS OR SERVICES DOES NOT CONSTITUTE AN ENDORSEMENT REGARDING THE SUITABILITY OF SUCH PRODUCTS OR SERVICES OR A WARRANTY, REPRESENTATION OR ENDORSEMENT OF SUCH PRODUCTS OR SERVICES, EITHER ALONE OR IN COMBINATION WITH ANY TI PRODUCT OR SERVICE.

11.2 Trademarks

All trademarks are the property of their respective owners.

11.3 Electrostatic Discharge Caution



These devices have limited built-in ESD protection. The leads should be shorted together or the device placed in conductive foam during storage or handling to prevent electrostatic damage to the MOS gates.

11.4 Glossary

[SLYZ022](#) — *TI Glossary*.

This glossary lists and explains terms, acronyms, and definitions.

12 Mechanical, Packaging, and Orderable Information

The following pages include mechanical, packaging, and orderable information. This information is the most current data available for the designated devices. This data is subject to change without notice and revision of this document. For browser-based versions of this data sheet, refer to the left-hand navigation.

PACKAGING INFORMATION

Orderable Device	Status (1)	Package Type	Package Drawing	Pins	Package Qty	Eco Plan (2)	Lead/Ball Finish (6)	MSL Peak Temp (3)	Op Temp (°C)	Device Marking (4/5)	Samples
TPS61087DRCR	ACTIVE	VSON	DRC	10	3000	Green (RoHS & no Sb/Br)	CU NIPDAU	Level-2-260C-1 YEAR	-40 to 85	PMOQ	Samples
TPS61087DRCRG4	ACTIVE	VSON	DRC	10	3000	Green (RoHS & no Sb/Br)	CU NIPDAU	Level-2-260C-1 YEAR	-40 to 85	PMOQ	Samples
TPS61087DRCT	ACTIVE	VSON	DRC	10	250	Green (RoHS & no Sb/Br)	CU NIPDAU	Level-2-260C-1 YEAR	-40 to 85	PMOQ	Samples
TPS61087DSCR	ACTIVE	WSON	DSC	10	3000	Green (RoHS & no Sb/Br)	CU NIPDAU	Level-2-260C-1 YEAR	-40 to 85	PMWI	Samples
TPS61087DSCT	ACTIVE	WSON	DSC	10	250	Green (RoHS & no Sb/Br)	CU NIPDAU	Level-2-260C-1 YEAR	-40 to 85	PMWI	Samples

(1) The marketing status values are defined as follows:

ACTIVE: Product device recommended for new designs.

LIFEBUY: TI has announced that the device will be discontinued, and a lifetime-buy period is in effect.

NRND: Not recommended for new designs. Device is in production to support existing customers, but TI does not recommend using this part in a new design.

PREVIEW: Device has been announced but is not in production. Samples may or may not be available.

OBSELETE: TI has discontinued the production of the device.

(2) **RoHS:** TI defines "RoHS" to mean semiconductor products that are compliant with the current EU RoHS requirements for all 10 RoHS substances, including the requirement that RoHS substance do not exceed 0.1% by weight in homogeneous materials. Where designed to be soldered at high temperatures, "RoHS" products are suitable for use in specified lead-free processes. TI may reference these types of products as "Pb-Free".

RoHS Exempt: TI defines "RoHS Exempt" to mean products that contain lead but are compliant with EU RoHS pursuant to a specific EU RoHS exemption.

Green: TI defines "Green" to mean the content of Chlorine (Cl) and Bromine (Br) based flame retardants meet JS709B low halogen requirements of <=1000ppm threshold. Antimony trioxide based flame retardants must also meet the <=1000ppm threshold requirement.

(3) MSL, Peak Temp. - The Moisture Sensitivity Level rating according to the JEDEC industry standard classifications, and peak solder temperature.

(4) There may be additional marking, which relates to the logo, the lot trace code information, or the environmental category on the device.

(5) Multiple Device Markings will be inside parentheses. Only one Device Marking contained in parentheses and separated by a "-" will appear on a device. If a line is indented then it is a continuation of the previous line and the two combined represent the entire Device Marking for that device.

(6) Lead/Ball Finish - Orderable Devices may have multiple material finish options. Finish options are separated by a vertical ruled line. Lead/Ball Finish values may wrap to two lines if the finish value exceeds the maximum column width.

Important Information and Disclaimer: The information provided on this page represents TI's knowledge and belief as of the date that it is provided. TI bases its knowledge and belief on information provided by third parties, and makes no representation or warranty as to the accuracy of such information. Efforts are underway to better integrate information from third parties. TI has taken and continues to take reasonable steps to provide representative and accurate information but may not have conducted destructive testing or chemical analysis on incoming materials and chemicals. TI and TI suppliers consider certain information to be proprietary, and thus CAS numbers and other limited information may not be available for release.

In no event shall TI's liability arising out of such information exceed the total purchase price of the TI part(s) at issue in this document sold by TI to Customer on an annual basis.

OTHER QUALIFIED VERSIONS OF TPS61087 :

- Automotive: [TPS61087-Q1](#)

NOTE: Qualified Version Definitions:

- Automotive - Q100 devices qualified for high-reliability automotive applications targeting zero defects

TAPE AND REEL INFORMATION

QUADRANT ASSIGNMENTS FOR PIN 1 ORIENTATION IN TAPE

*All dimensions are nominal

Device	Package Type	Package Drawing	Pins	SPQ	Reel Diameter (mm)	Reel Width W1 (mm)	A0 (mm)	B0 (mm)	K0 (mm)	P1 (mm)	W (mm)	Pin1 Quadrant
TPS61087DRCR	VSON	DRC	10	3000	330.0	12.4	3.3	3.3	1.1	8.0	12.0	Q2
TPS61087DRCR	VSON	DRC	10	3000	330.0	12.4	3.3	3.3	1.1	8.0	12.0	Q2
TPS61087DRCT	VSON	DRC	10	250	180.0	12.4	3.3	3.3	1.1	8.0	12.0	Q2
TPS61087DRCT	VSON	DRC	10	250	180.0	12.5	3.3	3.3	1.1	8.0	12.0	Q2
TPS61087DSCR	WSON	DSC	10	3000	330.0	12.4	3.3	3.3	1.1	8.0	12.0	Q2
TPS61087DSCT	WSON	DSC	10	250	180.0	12.4	3.3	3.3	1.1	8.0	12.0	Q2

TAPE AND REEL BOX DIMENSIONS

*All dimensions are nominal

Device	Package Type	Package Drawing	Pins	SPQ	Length (mm)	Width (mm)	Height (mm)
TPS61087DRCR	VSON	DRC	10	3000	367.0	367.0	35.0
TPS61087DRCR	VSON	DRC	10	3000	338.0	355.0	50.0
TPS61087DRCT	VSON	DRC	10	250	210.0	185.0	35.0
TPS61087DRCT	VSON	DRC	10	250	338.0	355.0	50.0
TPS61087DSCR	WSON	DSC	10	3000	367.0	367.0	35.0
TPS61087DSCT	WSON	DSC	10	250	210.0	185.0	35.0

GENERIC PACKAGE VIEW

DRC 10

VSON - 1 mm max height

PLASTIC SMALL OUTLINE - NO LEAD

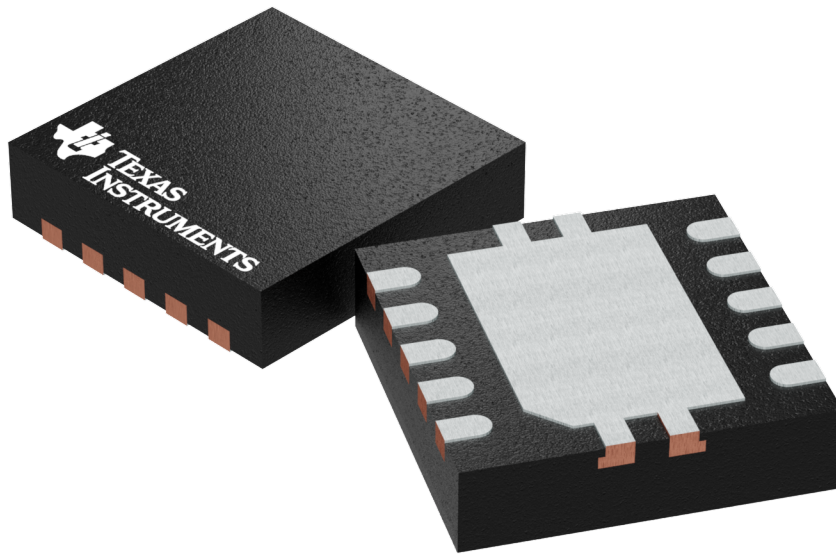

Images above are just a representation of the package family, actual package may vary.
Refer to the product data sheet for package details.

4204102-3/M

EXAMPLE BOARD LAYOUT

DRC0010J

VSON - 1 mm max height

PLASTIC SMALL OUTLINE - NO LEAD

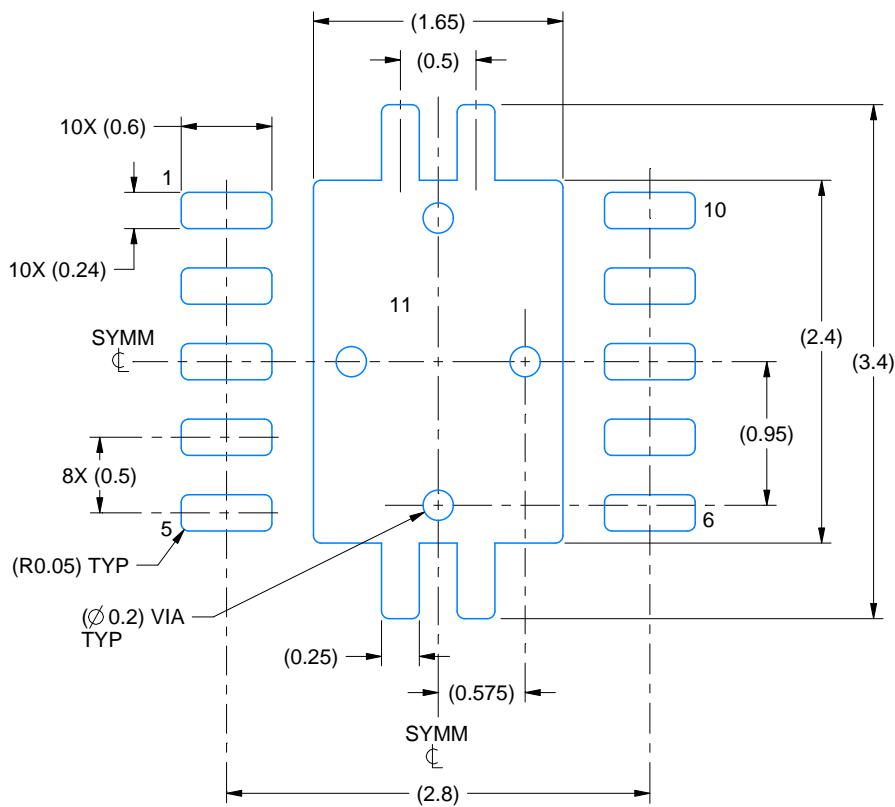

LAND PATTERN EXAMPLE
EXPOSED METAL SHOWN
SCALE:20X

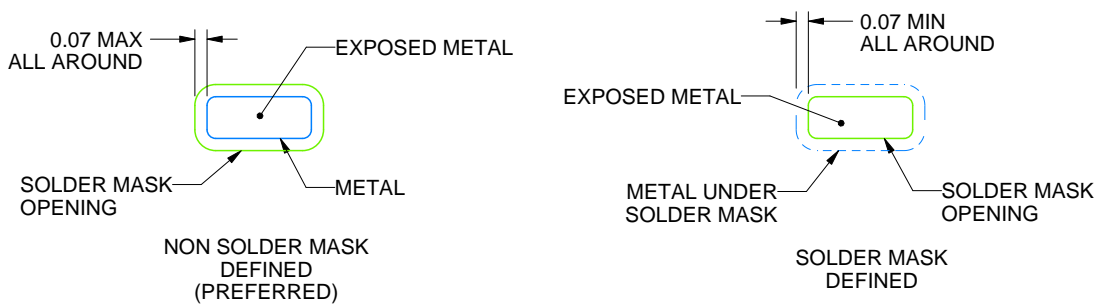

SOLDER MASK DETAILS

4218878/B 07/2018

NOTES: (continued)

4. This package is designed to be soldered to a thermal pad on the board. For more information, see Texas Instruments literature number SLUA271 (www.ti.com/lit/slua271).
5. Vias are optional depending on application, refer to device data sheet. If any vias are implemented, refer to their locations shown on this view. It is recommended that vias under paste be filled, plugged or tented.

GENERIC PACKAGE VIEW

DSC 10

WSON - 0.8 mm max height

PLASTIC SMALL OUTLINE - NO LEAD

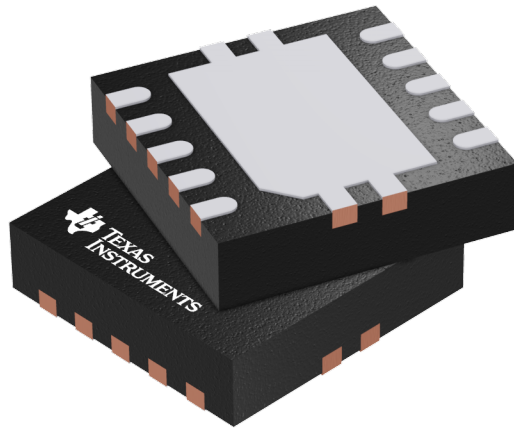

Images above are just a representation of the package family, actual package may vary.
Refer to the product data sheet for package details.

4207383/F

EXAMPLE STENCIL DESIGN

DSC0010J

WSON - 0.8 mm max height

PLASTIC SMALL OUTLINE - NO LEAD

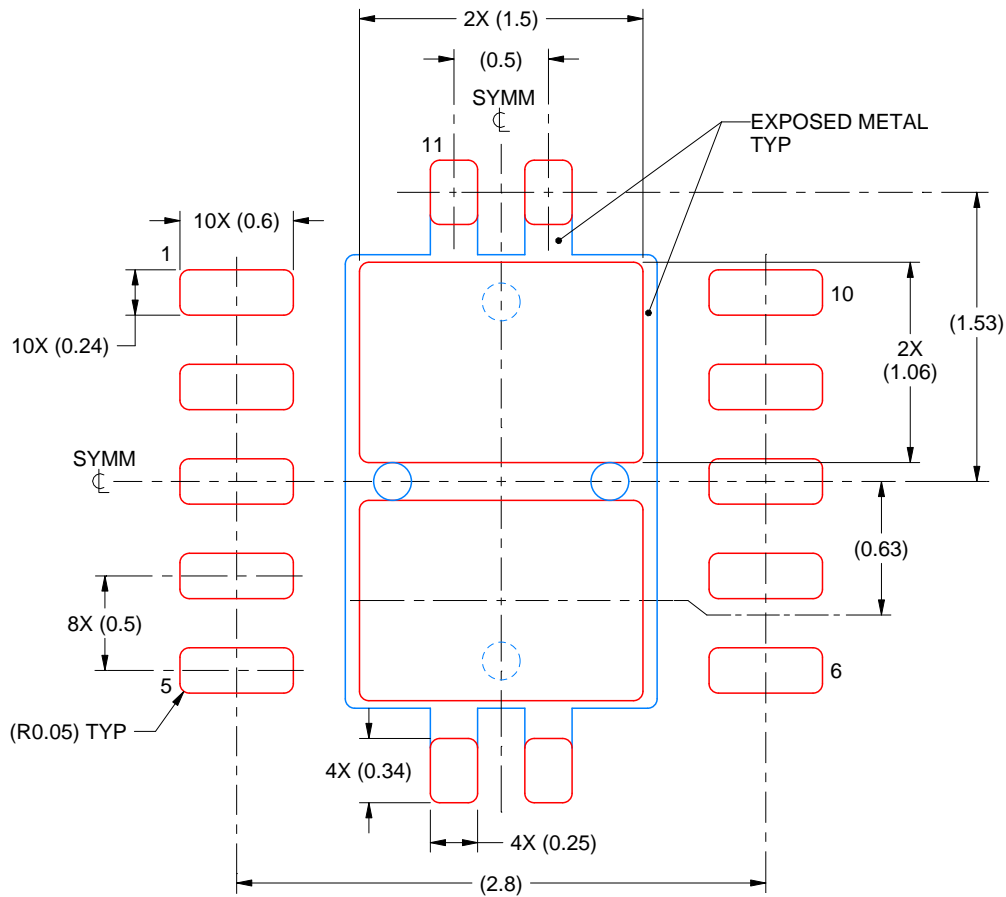

SOLDER PASTE EXAMPLE
BASED ON 0.125 mm THICK STENCIL

EXPOSED PAD 11:
80% PRINTED SOLDER COVERAGE BY AREA
SCALE:25X

4221826/D 08/2018

NOTES: (continued)

6. Laser cutting apertures with trapezoidal walls and rounded corners may offer better paste release. IPC-7525 may have alternate design recommendations.

IMPORTANT NOTICE AND DISCLAIMER

TI PROVIDES TECHNICAL AND RELIABILITY DATA (INCLUDING DATASHEETS), DESIGN RESOURCES (INCLUDING REFERENCE DESIGNS), APPLICATION OR OTHER DESIGN ADVICE, WEB TOOLS, SAFETY INFORMATION, AND OTHER RESOURCES "AS IS" AND WITH ALL FAULTS, AND DISCLAIMS ALL WARRANTIES, EXPRESS AND IMPLIED, INCLUDING WITHOUT LIMITATION ANY IMPLIED WARRANTIES OF MERCHANTABILITY, FITNESS FOR A PARTICULAR PURPOSE OR NON-INFRINGEMENT OF THIRD PARTY INTELLECTUAL PROPERTY RIGHTS.

These resources are intended for skilled developers designing with TI products. You are solely responsible for (1) selecting the appropriate TI products for your application, (2) designing, validating and testing your application, and (3) ensuring your application meets applicable standards, and any other safety, security, or other requirements. These resources are subject to change without notice. TI grants you permission to use these resources only for development of an application that uses the TI products described in the resource. Other reproduction and display of these resources is prohibited. No license is granted to any other TI intellectual property right or to any third party intellectual property right. TI disclaims responsibility for, and you will fully indemnify TI and its representatives against, any claims, damages, costs, losses, and liabilities arising out of your use of these resources.

TI's products are provided subject to TI's Terms of Sale (www.ti.com/legal/termsofsale.html) or other applicable terms available either on ti.com or provided in conjunction with such TI products. TI's provision of these resources does not expand or otherwise alter TI's applicable warranties or warranty disclaimers for TI products.

Mailing Address: Texas Instruments, Post Office Box 655303, Dallas, Texas 75265
Copyright © 2019, Texas Instruments Incorporated

Looking for pricing, stock, or lifecycle information?

Click below to explore more details on WIN SOURCE:

 [View TPS61087DRCR on WIN SOURCE](#)

 [Texas Instruments](#) Information

Optimize Your Supply Chain with WIN SOURCE Solutions

-  Global Sourcing Solution
-  Obsolete Management
-  Cost Control Management
-  Shortage Management
-  Alternative Solution
-  Excess Inventory Management