



**THE DATASHEET OF  
TPS61093DSK**



# TPS61093 Low-Input Boost Converter With Integrated Power Diode and Input/Output Isolation

## 1 Features

- Input range: 1.6 V to 6 V
- Integrated power diode and isolation FET
- 20-V Internal switch FET with 1.1-A current
- Fixed 1.2-MHz switching frequency
- Efficiency at 15-V output up to 88%
- Overload and overvoltage protection
- Programmable soft start-up
- Load discharge path after IC shutdown
- 2.5 mm × 2.5 mm × 0.8 mm WSON package
- Create a custom design using the TPS61093 with the [WEBENCH® Power Designer](#)

## 2 Applications

- Glucose meters
- OLED power supplies
- 3.3-V to 12-V, 5-V to 12-V Boost converters

## 3 Description

The TPS61093 is a 1.2-MHz, fixed-frequency boost converter designed for high integration and high reliability. The IC integrates a 20-V power switch, input/output isolation switch, and power diode. When the output current exceeds the overload limit, the isolation switch of the IC opens up to disconnect the output from the input, thus protecting the IC and the input supply. The isolation switch also disconnects the output from the input during shutdown to minimize leakage current. When the IC is shut down, the output capacitor is discharged to a low voltage level by internal diodes. Other protection features include 1.1-A peak overcurrent protection (OCP) at each cycle, output overvoltage protection (OVP), thermal shutdown, and undervoltage lockout (UVLO).

With its 1.6-V minimum input voltage, the IC can be powered by two alkaline batteries, a single Li-ion battery, or 3.3-V and 5-V regulated supply. The output can be boosted up to 17 V. The TPS61093 is available in 2.5 mm × 2.5 mm VSON package with thermal pad.

### Device Information<sup>(1)</sup>

PART NUMBER	PACKAGE	BODY SIZE (NOM)
TPS61093	WSON (10)	2.50 mm × 2.50 mm

(1) For all available packages, see the orderable addendum at the end of the data sheet.

### Simplified Schematic

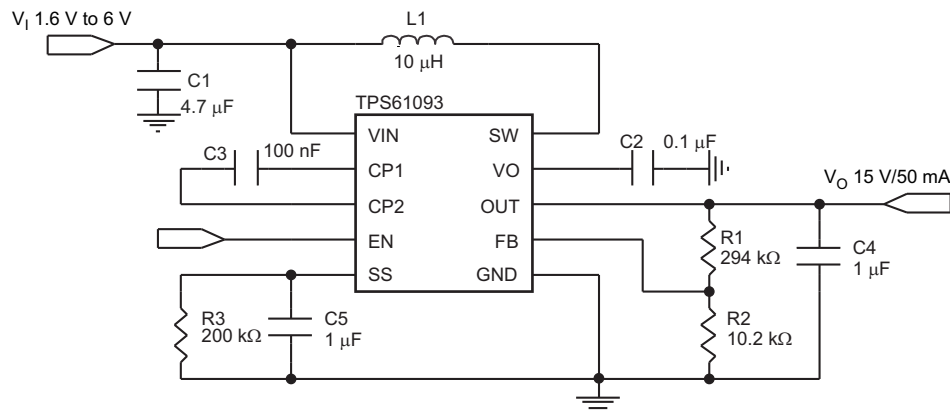

## Table of Contents

<b>1 Features</b> .....	<b>1</b>	7.4 Device Functional Modes.....	<b>8</b>
<b>2 Applications</b> .....	<b>1</b>	<b>8 Application and Implementation</b> .....	<b>9</b>
<b>3 Description</b> .....	<b>1</b>	8.1 Application Information.....	<b>9</b>
<b>4 Revision History</b> .....	<b>2</b>	8.2 Typical Applications .....	<b>9</b>
<b>5 Pin Configuration and Functions</b> .....	<b>3</b>	<b>9 Power Supply Recommendations</b> .....	<b>17</b>
<b>6 Specifications</b> .....	<b>3</b>	<b>10 Layout</b> .....	<b>17</b>
6.1 Absolute Maximum Ratings .....	<b>3</b>	10.1 Layout Guidelines .....	<b>17</b>
6.2 ESD Ratings.....	<b>4</b>	10.2 Layout Example .....	<b>17</b>
6.3 Recommended Operating Conditions.....	<b>4</b>	<b>11 Device and Documentation Support</b> .....	<b>18</b>
6.4 Thermal Information .....	<b>4</b>	11.1 Device Support.....	<b>18</b>
6.5 Electrical Characteristics.....	<b>5</b>	11.2 Receiving Notification of Documentation Updates	<b>18</b>
6.6 Typical Characteristics .....	<b>5</b>	11.3 Community Resources.....	<b>18</b>
<b>7 Detailed Description</b> .....	<b>7</b>	11.4 Trademarks .....	<b>18</b>
7.1 Overview .....	<b>7</b>	11.5 Electrostatic Discharge Caution.....	<b>18</b>
7.2 Functional Block Diagram .....	<b>7</b>	11.6 Glossary .....	<b>19</b>
7.3 Feature Description.....	<b>8</b>	<b>12 Mechanical, Packaging, and Orderable Information</b> .....	<b>19</b>

## 4 Revision History

### Changes from Revision C (June 2015) to Revision D Page

- Added links for Webench .....
- Changed *Shutdown and Load Discharge* output voltage value from "3.3 V" to "4.3 V" .....

### Changes from Revision B (December 2014) to Revision C Page

- Changed *Features* From: VSON package To: WSON Package .....
- Changed the pinout title From "QFN Package 10 Pins" To: "DSK Package 10 Pins (WSON)" .....
- Changed "VSON" to "WSON" in the *Thermal Information* table .....
- Deleted the *Dissipation Ratings* table.....

### Changes from Revision A (October 2009) to Revision B Page

- Added *ESD Ratings* table, *Feature Description* section, *Device Functional Modes*, *Application and Implementation* section, *Power Supply Recommendations* section, *Layout* section, *Device and Documentation Support* section, and *Mechanical, Packaging, and Orderable Information* section .....

### Changes from Original (September 2009) to Revision A Page

- Added information to OPERATION description.....
- Changed *Output Program* description .....
- Changed *Output Program* equations.....

## 5 Pin Configuration and Functions

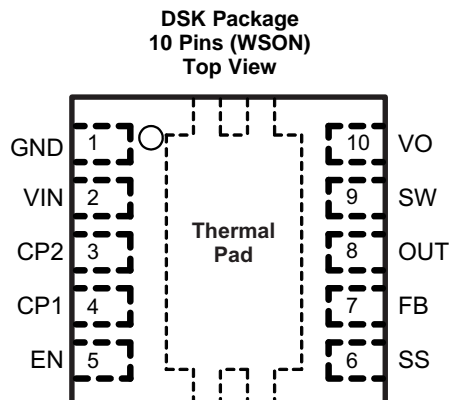

**Pin Functions**

PIN		I/O	DESCRIPTION
NAME	NO.		
CP1, CP2	3, 4		Connect to flying capacitor for internal charge pump.
EN	5	I	Enable pin (HIGH = enable). When the pin is pulled low for 1 ms, the IC turns off and consumes less than 1- $\mu$ A current.
FB	7	I	Voltage feedback pin for output regulation, 0.5-V regulated voltage. An external resistor divider connected to this pin programs the regulated output voltage.
GND	1	–	Ground of the IC.
OUT	8	O	Isolation switch is between this pin and VO pin. Connect load to this pin for input/output isolation during IC shutdown. See <i>Without Isolation FET</i> for the tradeoff between isolation and efficiency.
SS	6	I	Soft start pin. A RC network connecting to the SS pin programs soft start timing. See <i>Start-Up</i> .
SW	9	I	Switching node of the IC where the internal PWM switch operates.
Thermal Pad	–	–	It should be soldered to the ground plane. If possible, use thermal via to connect to ground plane for ideal power dissipation.
VIN	2	I	IC Supply voltage input.
VO	10	O	Output of the boost converter. When the output voltage exceeds the overvoltage protection (OVP) threshold, the power switch turns off until VO drops below the overvoltage protection hysteresis.

## 6 Specifications

### 6.1 Absolute Maximum Ratings

over operating free-air temperature (unless otherwise noted) <sup>(1)</sup>

		MIN	MAX	UNIT
Supply voltage on pin VIN <sup>(2)</sup>		–0.3	7	V
Voltage on pins CP2, EN, and SS <sup>(2)</sup>		–0.3	7	V
Voltage on pin CP1 and FB <sup>(2)</sup>		–0.3	3	V
Voltage on pin SW, VO, and OUT <sup>(2)</sup>		–0.3	20	V
T <sub>A</sub>	Operating temperature	–40	85	°C
T <sub>J</sub>	Maximum operating junction temperature		150	°C
T <sub>stg</sub>	Storage temperature	–55	150	°C

- (1) Stresses beyond those listed under *Absolute Maximum Ratings* may cause permanent damage to the device. These are stress ratings only and functional operation of the device at these or any other conditions beyond those indicated under *Recommended Operating Conditions* is not implied. Exposure to absolute-maximum-rated conditions for extended periods may affect device reliability.
- (2) All voltage values are with respect to network ground terminal.

## 6.2 ESD Ratings

		VALUE	UNIT
V <sub>(ESD)</sub>	Electrostatic discharge	Human-body model (HBM), per ANSI/ESDA/JEDEC JS-001 <sup>(1)</sup>	V
		Charged-device model (CDM), per JEDEC specification JESD22-C101 <sup>(2)</sup>	
		±2000	
		±750	

(1) JEDEC document JEP155 states that 500-V HBM allows safe manufacturing with a standard ESD control process.

(2) JEDEC document JEP157 states that 250-V CDM allows safe manufacturing with a standard ESD control process.

## 6.3 Recommended Operating Conditions

over operating free-air temperature range (unless otherwise noted)

		MIN	NOM	MAX	UNIT
V <sub>i</sub>	Input voltage range	1.6		6	V
V <sub>o</sub>	Output voltage range at VO pin			17	V
L	Inductor <sup>(1)</sup>	2.2	4.7	10	μH
C <sub>in</sub>	Input capacitor	4.7			μF
C <sub>o</sub>	Output capacitor at OUT pin <sup>(1)</sup>	1		10	μF
C <sub>fly</sub>	Flying capacitor at CP1 and CP2 pins	10			nF
T <sub>J</sub>	Operating junction temperature	−40		125	°C
T <sub>A</sub>	Operating free-air temperature	−40		85	°C

(1) These values are recommended values that have been successfully tested in several applications. Other values may be acceptable in other applications but should be fully tested by the user.

## 6.4 Thermal Information

THERMAL METRIC <sup>(1)</sup>		TPS61093	UNIT
		WS0N	
		10 PINS	
R <sub>θJA</sub>	Junction-to-ambient thermal resistance	49.2	°C/W
R <sub>θJC(top)</sub>	Junction-to-case (top) thermal resistance	63.3	
R <sub>θJB</sub>	Junction-to-board thermal resistance	23.4	
ψ <sub>JT</sub>	Junction-to-top characterization parameter	1.1	
ψ <sub>JB</sub>	Junction-to-board characterization parameter	23.0	
R <sub>θJC(bot)</sub>	Junction-to-case (bottom) thermal resistance	5.7	

(1) For more information about traditional and new thermal metrics, see the *IC Package Thermal Metrics* application report, [SPRA953](#).

## 6.5 Electrical Characteristics

V<sub>IN</sub> = 3.6 V, EN = V<sub>IN</sub>, T<sub>A</sub> = –40°C to 85°C, typical values are at T<sub>A</sub> = 25°C (unless otherwise noted)

PARAMETER		TEST CONDITIONS	MIN	TYP	MAX	UNIT
<b>SUPPLY CURRENT</b>						
V <sub>IN</sub>	Input voltage range, V <sub>IN</sub>		1.6		6	V
I <sub>Q</sub>	Operating quiescent current into V <sub>IN</sub>	Device PWM switching no load		0.9	1.5	mA
I <sub>SD</sub>	Shutdown current	EN = GND, V <sub>IN</sub> = 6 V			1	μA
UVLO	Undervoltage lockout threshold	V <sub>IN</sub> falling		1.5	1.55	V
V <sub>hys</sub>	Undervoltage lockout hysteresis			50		mV
<b>ENABLE AND PWM CONTROL</b>						
V <sub>ENH</sub>	EN logic high voltage	V <sub>IN</sub> = 1.6 V to 6 V	1.2			V
V <sub>ENL</sub>	EN logic low voltage	V <sub>IN</sub> = 1.6 V to 6 V			0.3	V
R <sub>EN</sub>	EN pull down resistor		400	800	1600	kΩ
T <sub>off</sub>	EN pulse width to shutdown	EN high to low			1	ms
<b>VOLTAGE CONTROL</b>						
V <sub>REF</sub>	Voltage feedback regulation voltage		0.49	0.5	0.51	V
I <sub>FB</sub>	Voltage feedback input bias current				100	nA
f <sub>S</sub>	Oscillator frequency		1.0	1.2	1.4	MHz
D <sub>max</sub>	Maximum duty cycle	V <sub>FB</sub> = 0.1 V, T <sub>A</sub> = 85°C	90%	93%		
T <sub>min_on</sub>	Minimum on pulse width			65		ns
<b>POWER SWITCH, ISOLATION FET</b>						
R <sub>DS(ON)N</sub>	N-channel MOSFET on-resistance	V <sub>IN</sub> = 3 V		0.25	0.4	Ω
R <sub>DS(ON)iso</sub>	Isolation FET on-resistance	VO = 5 V		2.5	4	Ω
		VO = 3.5 V		4.5		
I <sub>LN_N</sub>	N-channel leakage current	V <sub>DS</sub> = 20 V, T <sub>A</sub> = 25°C			1	μA
I <sub>LN_iso</sub>	Isolation FET leakage current	V <sub>DS</sub> = 20 V, T <sub>A</sub> = 25°C			1	μA
V <sub>F</sub>	Power diode forward voltage	Current = 500 mA		0.8		V
<b>OC, ILIM, OVP SC AND SS</b>						
I <sub>LIM</sub>	N-Channel MOSFET current limit		0.9	1.1	1.5	A
V <sub>ovp</sub>	Overvoltage protection threshold	Measured on the VO pin	18	19		V
V <sub>ovp_hys</sub>	Overvoltage protection hysteresis			0.6		V
I <sub>OL</sub>	Overload protection		200	300		mA
<b>THERMAL SHUTDOWN</b>						
T <sub>shutdown</sub>	Thermal shutdown threshold			150		°C
T <sub>hysteresis</sub>	Thermal shutdown hysteresis			15		°C

## 6.6 Typical Characteristics

Table 1. Table Of Graphs

Figure 1, L = TOKO #A915_Y-100M, unless otherwise noted			FIGURE
η	Efficiency	vs Load current at OUT = 15 V	Figure 1
η	Efficiency	vs Load current at OUT = 10 V	Figure 2
V <sub>FB</sub>	FB voltage	vs Free-air temperature	Figure 3
V <sub>FB</sub>	FB voltage	vs Input voltage	Figure 4
I <sub>LIM</sub>	Switch current limit	vs Free-air temperature	Figure 5

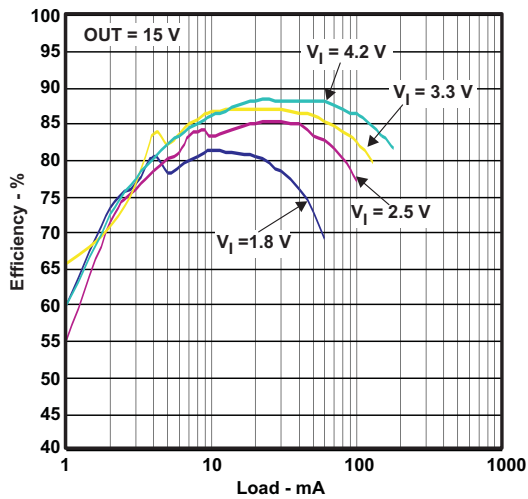

Figure 1. Efficiency vs Load

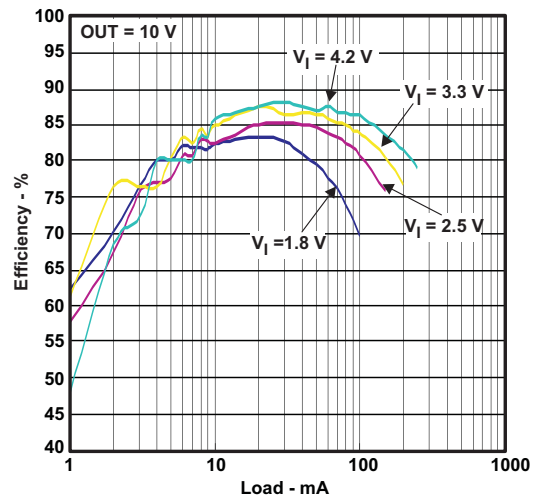

Figure 2. Efficiency vs Load

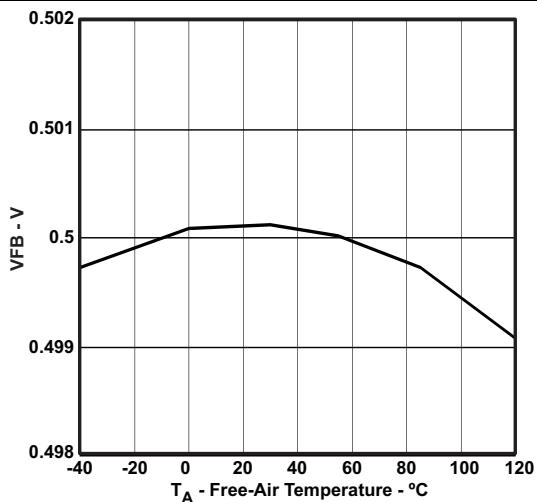

Figure 3. FB Voltage vs Free-Air Temperature

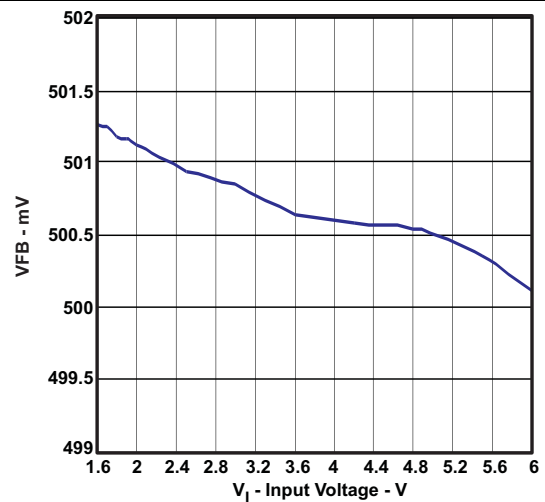

Figure 4. FB Voltage vs Input Voltage

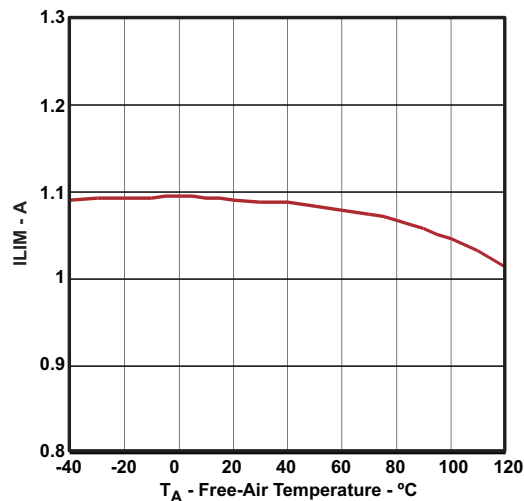

Figure 5. Switch Current Limit vs Free-Air Temperature

## 7 Detailed Description

### 7.1 Overview

The TPS61093 is a highly integrated boost regulator for up to 17-V output. In addition to the on-chip 1-A PWM switch and power diode, this IC also integrates an output-side isolation switch as shown in the functional block diagram. One common issue with conventional boost regulators is the conduction path from input to output even when the PWM switch is turned off. It creates three problems, which are inrush current during start-up, output leakage current during shutdown, and excessive overload current. In the TPS61093, the isolation switch turns off under shutdown-mode and overload conditions, thereby opening the current path. However, shorting the VO and OUT pins bypasses the isolation switch and enhances efficiency. Because the isolation switch is on the output side, the IC's VIN pin and power stage input power (up to 10 V) can be separated.

The TPS61093 adopts current-mode control with constant pulse-width-modulation (PWM) frequency. The switching frequency is fixed at 1.2 MHz typical. PWM operation turns on the PWM switch at the beginning of each switching cycle. The input voltage is applied across the inductor and the inductor current ramps up. In this mode, the output capacitor is discharged by the load current. When the inductor current hits the threshold set by the error amplifier output, the PWM switch is turned off, and the power diode is forward-biased. The inductor transfers its stored energy to replenish the output capacitor. This operation repeats in the next switching cycle. The error amplifier compares the FB-pin voltage with an internal reference, and its output determines the duty cycle of the PWM switching. This closed-loop system requires frequency compensation for stable operation. The device has a built-in compensation circuit that can accommodate a wide range of input and output voltages. To avoid the sub-harmonic oscillation intrinsic to current-mode control, the IC also integrates slope compensation, which adds an artificial slope to the current ramp.

### 7.2 Functional Block Diagram

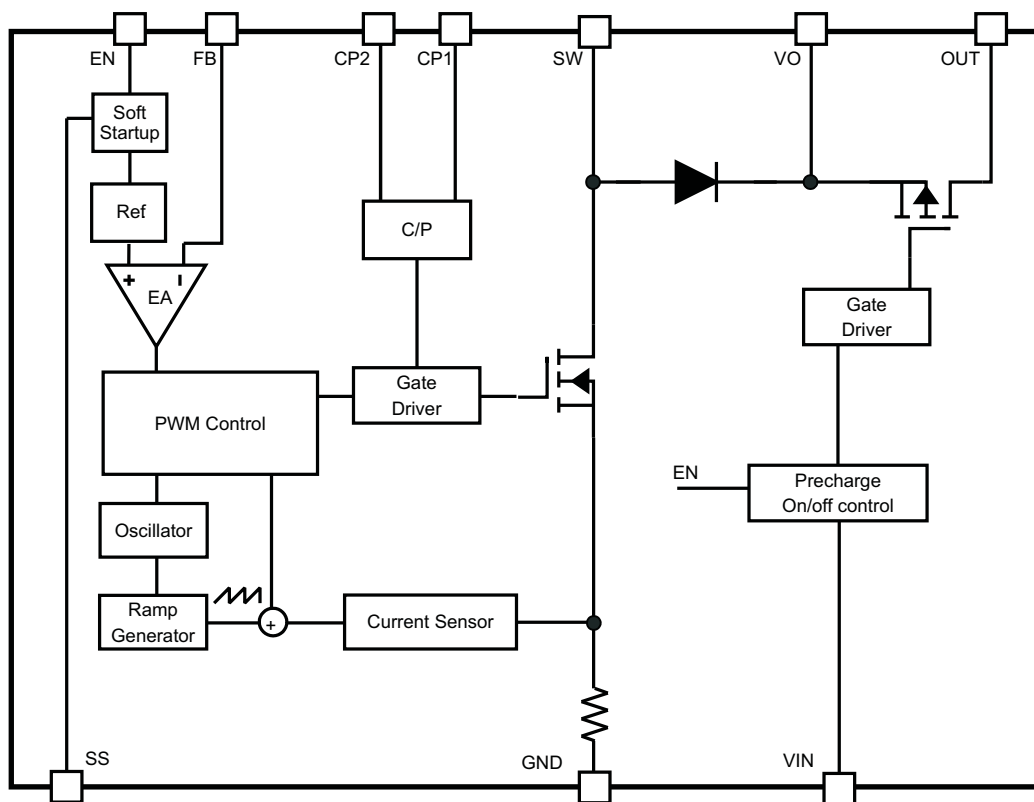

## 7.3 Feature Description

### 7.3.1 Shutdown and Load Discharge

When the EN pin is pulled low for 1 ms, the IC stops the PWM switch and turns off the isolation switch, providing isolation between input and output. The internal current path consisting of the isolation switch's body diode and several parasitic diodes quickly discharges the output voltage to less than 4.3 V. Afterwards, the voltage is slowly discharged to zero by the leakage current. This protects the IC and the external components from high voltage in shutdown mode.

In shutdown mode, less than 1  $\mu\text{A}$  of input current is consumed by the IC.

### 7.3.2 Overload and Overvoltage Protection

If the overload current passing through the isolation switch is above the overload limit ( $I_{OL}$ ) for 3- $\mu\text{s}$  (typical), the TPS61093 is switched off until the fault is cleared and the EN pin toggles. The function only is triggered 52 ms after the IC is enabled.

To prevent the PWM switch and the output capacitor from exceeding maximum voltage ratings, an overvoltage protection circuit turns off the boost switch as soon as the output voltage at the VO pin exceeds the OVP threshold. Simultaneously, the IC opens the isolation switch. The regulator resumes PWM switching after the VO pin voltage falls 0.6 V below the threshold.

### 7.3.3 UVLO

An undervoltage lockout prevents improper operation of the device for input voltages below 1.55 V. When the input voltage is below the undervoltage threshold, the entire device, including the PWM and isolation switches, remains off.

### 7.3.4 Thermal Shutdown

An internal thermal shutdown turns off the isolation and PWM switches when the typical junction temperature of 150°C is exceeded. The thermal shutdown has a hysteresis of 15°C, typical.

## 7.4 Device Functional Modes

The converter operates in continuous conduction mode (CCM) as soon as the input current increases above half the ripple current in the inductor, for lower load currents it switches into discontinuous conduction mode (DCM). If the load is further reduced, the part starts to skip pulses to maintain the output voltage.

## 8 Application and Implementation

### NOTE

Information in the following applications sections is not part of the TI component specification, and TI does not warrant its accuracy or completeness. TI's customers are responsible for determining suitability of components for their purposes. Customers should validate and test their design implementation to confirm system functionality.

### 8.1 Application Information

The device is a step up DC-DC converter with a PWM switch, a power diode and an input/output isolation switch integrated. TPS61093 supports up to 17-V output with the input range from 1.6 V to 6 V. The TPS61093 adopts the current-mode control with constant pulse-width-modulation (PWM) frequency. The switching frequency is fixed at 1.2 MHz typical. The isolation switch disconnects the output from the input during shutdown to minimize leakage current. However, shorting the VO and OUT pins bypasses the isolation switch and enhances efficiency. The following design procedure can be used to select component values for the TPS61093.

### 8.2 Typical Applications

#### 8.2.1 15 V Output Boost Converter

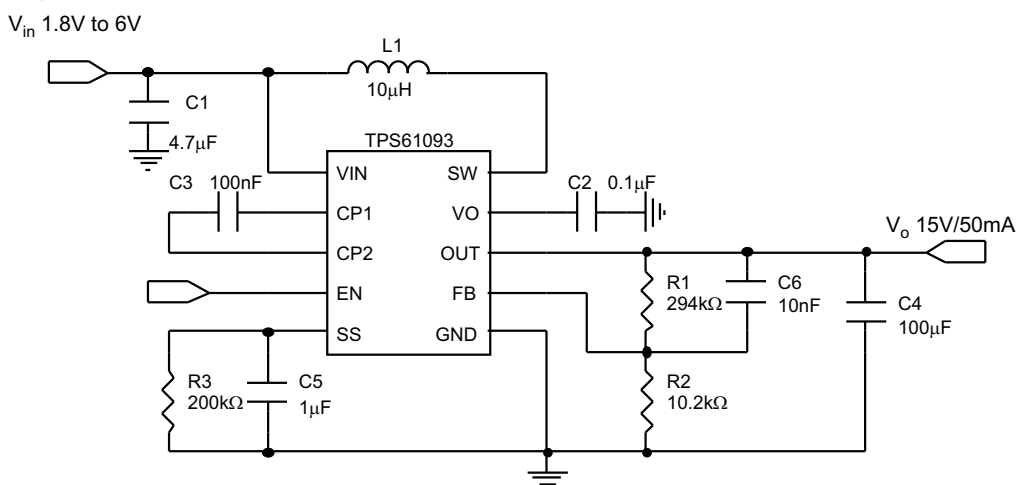

Figure 6. 15 V Boost Converter with 100  $\mu$ F Output Capacitor

#### 8.2.1.1 Design Requirements

Table 2. Design Parameters

PARAMETERS	VALUES
Input voltage	4.2 V
Output voltage	15 V
Operating frequency	1.2 MHz

### 8.2.1.2 Detailed Design Procedure

#### 8.2.1.2.1 Custom Design With WEBENCH® Tools

Click [here](#) to create a custom design using the TPS61093 device with the WEBENCH® Power Designer.

1. Start by entering the input voltage ( $V_{IN}$ ), output voltage ( $V_{OUT}$ ), and output current ( $I_{OUT}$ ) requirements.
2. Optimize the design for key parameters such as efficiency, footprint, and cost using the optimizer dial.
3. Compare the generated design with other possible solutions from Texas Instruments.

The WEBENCH Power Designer provides a customized schematic along with a list of materials with real-time pricing and component availability.

In most cases, these actions are available:

- Run electrical simulations to see important waveforms and circuit performance
- Run thermal simulations to understand board thermal performance
- Export customized schematic and layout into popular CAD formats
- Print PDF reports for the design, and share the design with colleagues

Get more information about WEBENCH tools at [www.ti.com/WEBENCH](http://www.ti.com/WEBENCH).

#### 8.2.1.2.2 Output Program

To program the output voltage, select the values of R1 and R2 (see [Figure 7](#)) according to [Equation 1](#).

$$V_{out} = 0.5 \text{ V} \times \left( \frac{R1}{R2} + 1 \right)$$

$$R1 = R2 \times \left( \frac{V_{out}}{0.5 \text{ V}} - 1 \right) \tag{1}$$

A recommended value for R2 is approximately 10 kΩ which sets the current in the resistor divider chain to 0.5 V/10 kΩ = 50 μA. The output voltage tolerance depends on the VFB accuracy and the resistor divider.

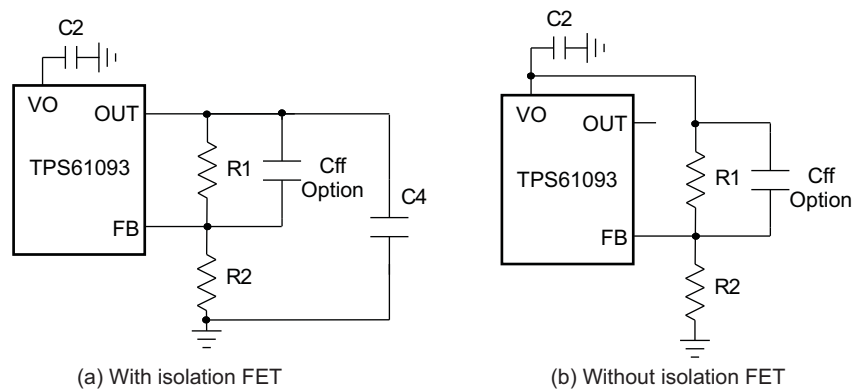

Figure 7. Resistor Divider to Program Output Voltage

#### 8.2.1.2.3 Without Isolation FET

The efficiency of the TPS61093 can be improved by connecting the load to the VO pin instead of the OUT pin. The power loss in the isolation FET is then negligible, as shown in [Figure 8](#). The tradeoffs when bypassing the isolation FET are:

- Leakage path between input and output causes the output to be a diode drop below the input voltage when the IC is in shutdown
- No overload circuit protection

When the load is connected to the VO pin, the output capacitor on the VO pin must be above 1 μF.

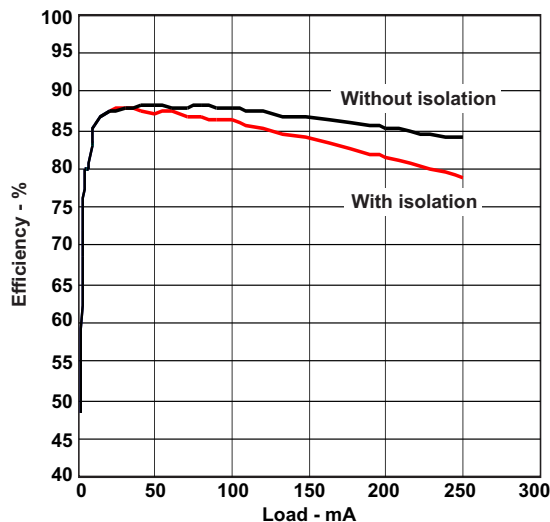

Figure 8. Efficiency vs Load

#### 8.2.1.2.4 Start-Up

The TPS61093 turns on the isolation FET and PWM switch when the EN pin is pulled high. During the soft-start period, the R and C network on the SS pin is charged by an internal bias current of 5  $\mu\text{A}$  (typical). The RC network sets the reference voltage ramp up slope. Because the output voltage follows the reference voltage via the FB pin, the output voltage rise time follows the SS pin voltage until the SS pin voltage reaches 0.5 V. The soft-start time is given by Equation 2.

$$t_{\text{SS}} = \frac{0.5 \text{ V} \times C5}{5 \mu\text{A}}$$

where

- C5 is the capacitor connected to the SS pin (2)

When the EN pin is pulled low to switch the IC off, the SS pin voltage is discharged to zero by the resistor R3. The discharge period depends on the RC time constant. Note that if the SS pin voltage is not discharged to zero before the IC is enabled again, the soft start circuit may not slow the output voltage startup and may not reduce the startup inrush current.

#### 8.2.1.2.5 Switch Duty Cycle

The maximum switch duty cycle (D) of the TPS61093 is 90% (minimum). The duty cycle of a boost converter under continuous conduction mode (CCM) is given by:

$$D = \frac{V_{\text{out}} + 0.8 \text{ V} - V_{\text{in}}}{V_{\text{out}} + 0.8 \text{ V}} \quad (3)$$

The duty cycle must be lower than the specification in the application; otherwise the output voltage cannot be regulated.

The TPS61093 has a minimum ON pulse width once the PWM switch is turned on. As the output current drops, the device enters discontinuous conduction mode (DCM). If the output current drops extremely low, causing the ON time to be reduced to the minimum ON time, the TPS61093 enters pulse-skipping mode. In this mode, the device keeps the power switch off for several switching cycles to keep the output voltage in regulation. See [Figure 14](#). The output current when the IC enters skipping mode is calculated with [Equation 4](#).

$$I_{\text{out\_skip}} = \frac{V_{\text{in}}^2 \times T_{\text{min\_on}}^2 \times f_{\text{SW}}}{2 \times (V_{\text{out}} + 0.8\text{V} - V_{\text{in}}) \times L}$$

where

- $T_{\text{min\_on}}$  = Minimum ON pulse width specification (typically 65-ns);
  - $L$  = Selected inductor value;
  - $f_{\text{SW}}$  = Converter switching frequency (typically 1.2-MHz)
- (4)

### 8.2.1.2.6 Inductor Selection

Because the selection of the inductor affects steady state operation, transient behavior, and loop stability, the inductor is the most important component in power regulator design. There are three important inductor specifications, inductor value, saturation current, and dc resistance. Considering inductor value alone is not enough.

The saturation current of the inductor should be higher than the peak switch current as calculated in [Equation 5](#).

$$I_{L\_peak} = I_{L\_DC} + \frac{\Delta I_L}{2}$$

$$I_{L\_DC} = \frac{V_{\text{out}} \times I_{\text{out}}}{V_{\text{in}} \times \eta}$$

$$\Delta I_L = \frac{1}{L \times f_{\text{SW}} \times \left( \frac{1}{V_{\text{out}} + 0.8\text{V} - V_{\text{IN}}} + \frac{1}{V_{\text{IN}}} \right)}$$

where

- $I_{L\_peak}$  = Peak switch current
  - $I_{L\_DC}$  = Inductor average current
  - $\Delta I_L$  = Inductor peak to peak current
  - $\eta$  = Estimated converter efficiency
- (5)

Normally, it is advisable to work with an inductor peak-to-peak current of less than 30% of the average inductor current. A smaller ripple from a larger valued inductor reduces the magnetic hysteresis losses in the inductor and EMI. But in the same way, load transient response time is increased. Also, the inductor value should not be outside the 2.2  $\mu\text{H}$  to 10  $\mu\text{H}$  range in the recommended operating conditions table. Otherwise, the internal slope compensation and loop compensation components are unable to maintain small signal control loop stability over the entire load range. [Table 3](#) lists the recommended inductor for the TPS61093.

**Table 3. Recommended Inductors for the TPS61093**

PART NUMBER	L ( $\mu\text{H}$ )	DCR MAX (m $\Omega$ )	SATURATION CURRENT (A)	SIZE (LxWxH mm)	VENDOR
#A915_Y-4R7M	4.7	45	1.5	5.2x5.2x3.0	Toko
#A915_Y-100M	10	90	1.09	5.2x5.2x3.0	Toko
VLS4012-4R7M	4.7	132	1.1	4.0x4.0x1.2	TDK
VLS4012-100M	10	240	0.82	4.0x4.0x1.2	TDK
CDRH3D23/HP	10	198	1.02	4.0x4.0x2.5	Sumida
LPS5030-103ML	10	127	1.4	5.0x5.0x3.0	Coilcraft

### 8.2.1.2.7 Input and Output Capacitor Selection

The output capacitor is mainly selected to meet the requirements for output ripple and loop stability. This ripple voltage is related to the capacitor's capacitance and its equivalent series resistance (ESR). Assuming a ceramic capacitor with zero ESR, the minimum capacitance needed for a given ripple can be calculated by:

$$C_{\text{out}} = \frac{D \times I_{\text{out}}}{F_s \times V_{\text{ripple}}}$$

where

- $V_{\text{ripple}}$  = peak to peak output ripple (6)

The ESR impact on the output ripple must be considered if tantalum or electrolytic capacitors are used.

Care must be taken when evaluating a ceramic capacitor's derating under dc bias, aging, and ac signal. For example, larger form factor capacitors (in 1206 size) have their self resonant frequencies in the range of the switching frequency. So the effective capacitance is significantly lower. The dc bias can also significantly reduce capacitance. A ceramic capacitor can lose as much as 50% of its capacitance at its rated voltage. Therefore, always leave margin on the voltage rating to ensure adequate capacitance at the required output voltage.

A 4.7- $\mu\text{F}$  (minimum) input capacitor is recommended. The output requires a capacitor in the range of 1  $\mu\text{F}$  to 10  $\mu\text{F}$ . The output capacitor affects the small signal control loop stability of the boost regulator. If the output capacitor is below the range, the boost regulator can potentially become unstable.

The popular vendors for high value ceramic capacitors are:

- TDK (<http://www.component.tdk.com/components.php>)
- Murata (<http://www.murata.com/cap/index.html>)

### 8.2.1.2.8 Small Signal Stability

The TPS61093 integrates slope compensation and the RC compensation network for the internal error amplifier. Most applications are control loop stable if the recommended inductor and input/output capacitors are used. For those few applications that require components outside the recommended values, the internal error amplifier's gain and phase are presented in [Figure 9](#).

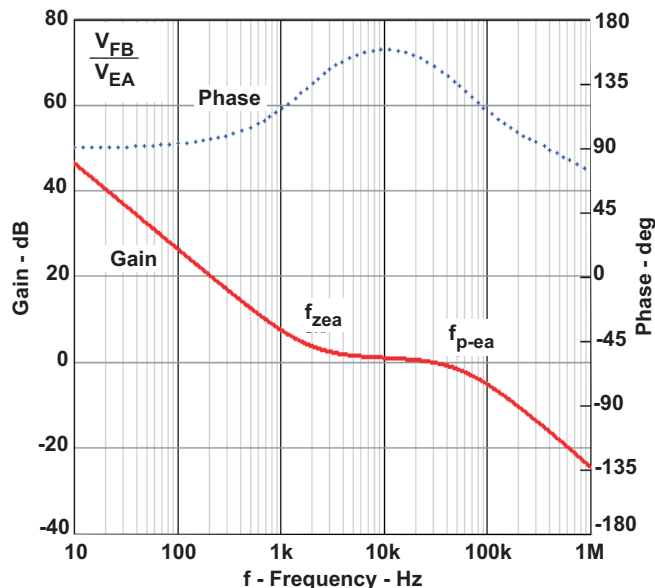

**Figure 9. Bode Plot of Error Amplifier Gain and Phase**

The RC compensation network generates a pole  $f_{p-ea}$  of 57 kHz and a zero  $f_{z-ea}$  of 1.9 kHz, shown in [Figure 9](#). Use [Equation 7](#) to calculate the output pole,  $f_p$ , of the boost converter. If  $f_p \ll f_{z-ea}$ , due to a large capacitor beyond 10  $\mu\text{F}$ , for example, a feed forward capacitor on the resistor divider, as shown in [Figure 9](#), is necessary to generate an additional zero  $f_{z-f}$  to improve the loop phase margin and improve the load transient response. The low frequency pole  $f_{p-f}$  and zero  $f_{z-f}$  generated by the feed forward capacitor are given by [Equation 8](#) and [Equation 9](#):

$$f_p = \frac{1}{\pi \times R_o \times C_o} \quad (\text{a}) \quad (7)$$

$$f_{p-f} = \frac{1}{2\pi \times R2 \times C_{ff}} \quad (\text{b}) \quad (8)$$

$$f_{z-f} = \frac{1}{2\pi \times R1 \times C_{ff}} \quad (\text{c})$$

where

- $C_{ff}$  = the feed-forward capacitor (9)

For example, in the typical application circuitry (see [Figure 7](#)), the output pole  $f_p$  is approximately 1 kHz. When the output capacitor is increased to 100  $\mu\text{F}$ , then the  $f_p$  is reduced to 10 Hz. Therefore, a feed-forward capacitor of 10 nF compensates for the low frequency pole.

A feed-forward capacitor that sets  $f_{z-f}$  near 10 kHz improves the load transient response in most applications, as shown in [Figure 11](#).

8.2.1.3 Application Curves

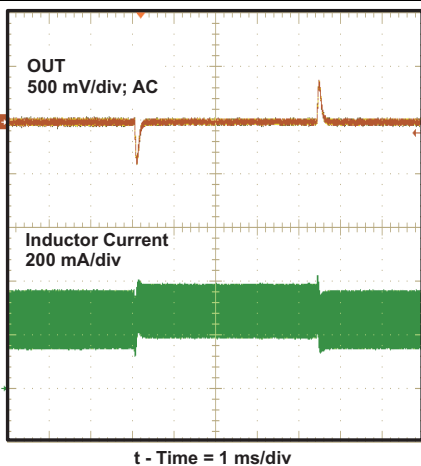

Figure 10. 3.3 V to 3.6 V Line Transient Response

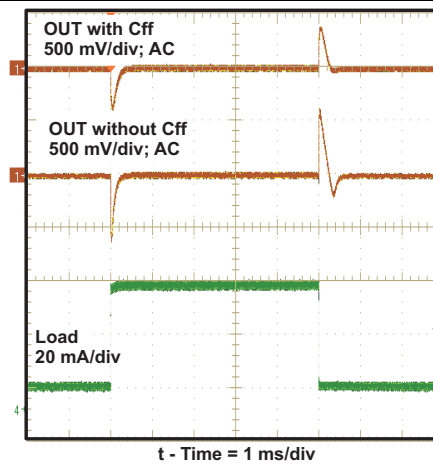

Figure 11. 10 mA to 50 mA Load Transient Response

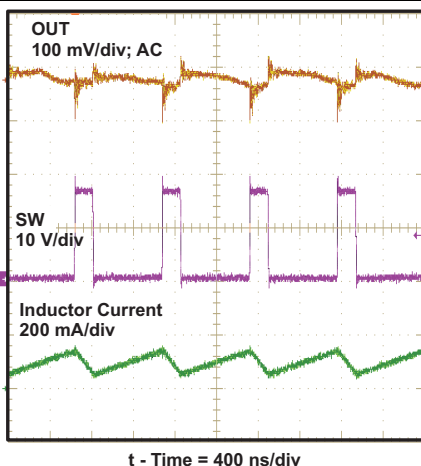

Figure 12. PWM Control in CCM

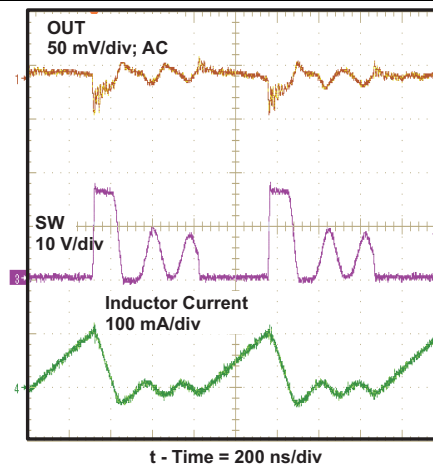

Figure 13. PWM Control in DCM

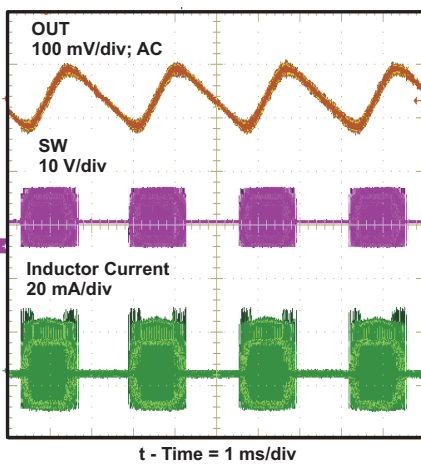

Figure 14. Pulse Skip Mode at Light Load

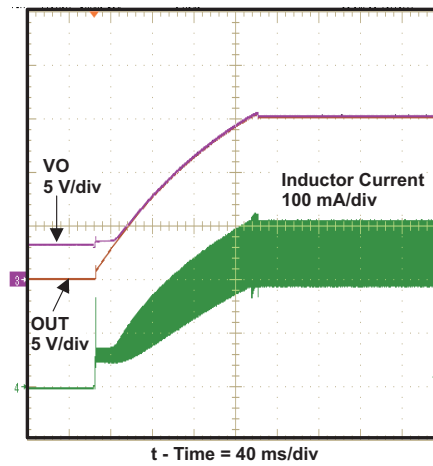

Figure 15. Soft Start-Up

### 8.2.2 10 V, -10 V Dual Output Boost Converter

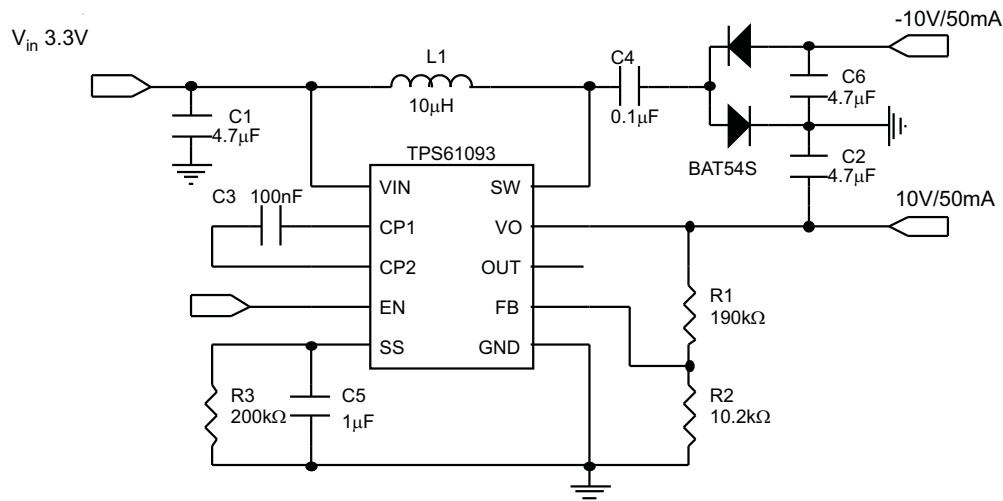

Figure 16. 10 V, -10 V Dual Output Boost Converter Schematic

#### 8.2.2.1 Design Requirements

Table 4. Design Parameters

PARAMETERS	VALUES
Input voltage	3.3 V
Output voltage	10 V/-10 V
Operating frequency	1.2 MHz

#### 8.2.2.2 Detailed Design Procedure

Refer to [Detailed Design Procedure](#) for the 15-V output boost converter.

#### 8.2.2.3 Application Curve

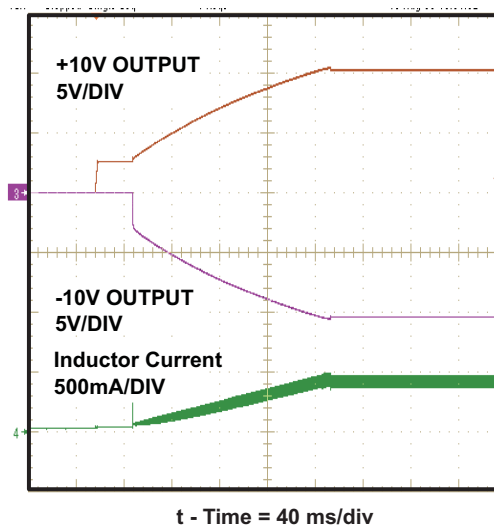

Figure 17. Soft Start-up Waveform, 10 V, -10 V Dual Output Boost Converter

## 9 Power Supply Recommendations

The device is designed to operate from an input voltage supply range between 1.6 V to 6 V. The input power supply's output current needs to be rated according to the supply voltage, output voltage and output current of the TPS61093.

## 10 Layout

### 10.1 Layout Guidelines

As for all switching power supplies, especially those running at high switching frequency and high currents, layout is an important design step. If layout is not carefully done, the regulator could suffer from instability as well as noise problems. To maximize efficiency, switch rise and fall times are very fast. To prevent radiation of high frequency noise (for example, EMI), proper layout of the high frequency switching path is essential. Minimize the length and area of all traces connected to the SW pin and always use a ground plane under the switching regulator to minimize interplane coupling. The high current path including the switch and output capacitor contains nanosecond rise and fall times and should be kept as short as possible. The input capacitor needs not only to be close to the VIN pin, but also to the GND pin in order to reduce input supply ripple.

### 10.2 Layout Example

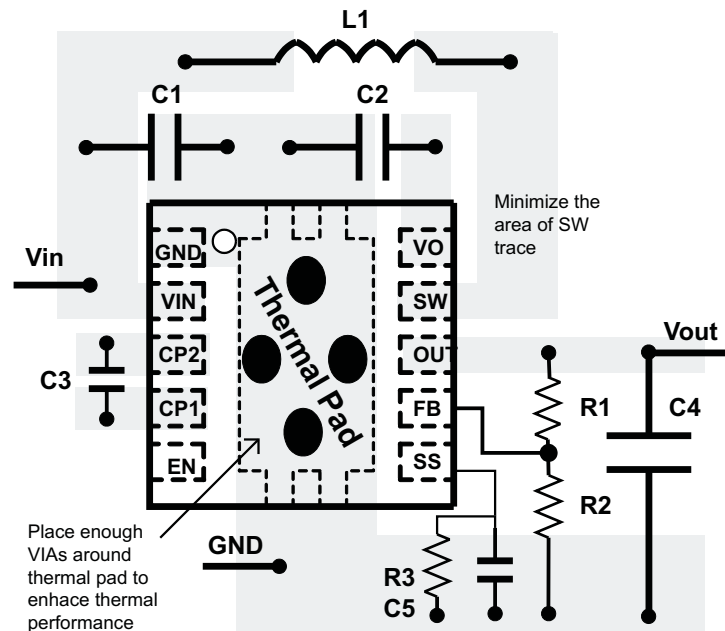

Figure 18. TPS61093QFN Board Layout

## 11 Device and Documentation Support

### 11.1 Device Support

#### 11.1.1 Third-Party Products Disclaimer

TI'S PUBLICATION OF INFORMATION REGARDING THIRD-PARTY PRODUCTS OR SERVICES DOES NOT CONSTITUTE AN ENDORSEMENT REGARDING THE SUITABILITY OF SUCH PRODUCTS OR SERVICES OR A WARRANTY, REPRESENTATION OR ENDORSEMENT OF SUCH PRODUCTS OR SERVICES, EITHER ALONE OR IN COMBINATION WITH ANY TI PRODUCT OR SERVICE.

#### 11.1.2 Development Support

##### 11.1.2.1 Custom Design With WEBENCH® Tools

[Click here](#) to create a custom design using the TPS61093 device with the WEBENCH® Power Designer.

1. Start by entering the input voltage ( $V_{IN}$ ), output voltage ( $V_{OUT}$ ), and output current ( $I_{OUT}$ ) requirements.
2. Optimize the design for key parameters such as efficiency, footprint, and cost using the optimizer dial.
3. Compare the generated design with other possible solutions from Texas Instruments.

The WEBENCH Power Designer provides a customized schematic along with a list of materials with real-time pricing and component availability.

In most cases, these actions are available:

- Run electrical simulations to see important waveforms and circuit performance
- Run thermal simulations to understand board thermal performance
- Export customized schematic and layout into popular CAD formats
- Print PDF reports for the design, and share the design with colleagues

Get more information about WEBENCH tools at [www.ti.com/WEBENCH](http://www.ti.com/WEBENCH).

### 11.2 Receiving Notification of Documentation Updates

To receive notification of documentation updates, navigate to the device product folder on ti.com. In the upper right corner, click on *Alert me* to register and receive a weekly digest of any product information that has changed. For change details, review the revision history included in any revised document.

### 11.3 Community Resources

The following links connect to TI community resources. Linked contents are provided "AS IS" by the respective contributors. They do not constitute TI specifications and do not necessarily reflect TI's views; see TI's [Terms of Use](#).

**TI E2E™ Online Community** *TI's Engineer-to-Engineer (E2E) Community*. Created to foster collaboration among engineers. At [e2e.ti.com](http://e2e.ti.com), you can ask questions, share knowledge, explore ideas and help solve problems with fellow engineers.

**Design Support** *TI's Design Support* Quickly find helpful E2E forums along with design support tools and contact information for technical support.

### 11.4 Trademarks

E2E is a trademark of Texas Instruments.  
 WEBENCH is a registered trademark of Texas Instruments.  
 All other trademarks are the property of their respective owners.

### 11.5 Electrostatic Discharge Caution



These devices have limited built-in ESD protection. The leads should be shorted together or the device placed in conductive foam during storage or handling to prevent electrostatic damage to the MOS gates.

## 11.6 Glossary

[SLYZ022](#) — *TI Glossary*.

This glossary lists and explains terms, acronyms, and definitions.

## 12 Mechanical, Packaging, and Orderable Information

The following pages include mechanical, packaging, and orderable information. This information is the most current data available for the designated devices. This data is subject to change without notice and revision of this document. For browser-based versions of this data sheet, refer to the left-hand navigation.

**PACKAGING INFORMATION**

Orderable Device	Status (1)	Package Type	Package Drawing	Pins	Package Qty	Eco Plan (2)	Lead/Ball Finish (6)	MSL Peak Temp (3)	Op Temp (°C)	Device Marking (4/5)	Samples
TPS61093DSKR	ACTIVE	SON	DSK	10	3000	Green (RoHS & no Sb/Br)	CU NIPDAU	Level-1-260C-UNLIM	-40 to 85	OAP	<a href="#">Samples</a>
TPS61093DSKT	ACTIVE	SON	DSK	10	250	Green (RoHS & no Sb/Br)	CU NIPDAU	Level-1-260C-UNLIM	-40 to 85	OAP	<a href="#">Samples</a>

(1) The marketing status values are defined as follows:

**ACTIVE:** Product device recommended for new designs.

**LIFEBUY:** TI has announced that the device will be discontinued, and a lifetime-buy period is in effect.

**NRND:** Not recommended for new designs. Device is in production to support existing customers, but TI does not recommend using this part in a new design.

**PREVIEW:** Device has been announced but is not in production. Samples may or may not be available.

**OBSOLETE:** TI has discontinued the production of the device.

(2) **RoHS:** TI defines "RoHS" to mean semiconductor products that are compliant with the current EU RoHS requirements for all 10 RoHS substances, including the requirement that RoHS substance do not exceed 0.1% by weight in homogeneous materials. Where designed to be soldered at high temperatures, "RoHS" products are suitable for use in specified lead-free processes. TI may reference these types of products as "Pb-Free".

**RoHS Exempt:** TI defines "RoHS Exempt" to mean products that contain lead but are compliant with EU RoHS pursuant to a specific EU RoHS exemption.

**Green:** TI defines "Green" to mean the content of Chlorine (Cl) and Bromine (Br) based flame retardants meet JS709B low halogen requirements of <=1000ppm threshold. Antimony trioxide based flame retardants must also meet the <=1000ppm threshold requirement.

(3) MSL, Peak Temp. - The Moisture Sensitivity Level rating according to the JEDEC industry standard classifications, and peak solder temperature.

(4) There may be additional marking, which relates to the logo, the lot trace code information, or the environmental category on the device.

(5) Multiple Device Markings will be inside parentheses. Only one Device Marking contained in parentheses and separated by a "~" will appear on a device. If a line is indented then it is a continuation of the previous line and the two combined represent the entire Device Marking for that device.

(6) Lead/Ball Finish - Orderable Devices may have multiple material finish options. Finish options are separated by a vertical ruled line. Lead/Ball Finish values may wrap to two lines if the finish value exceeds the maximum column width.

**Important Information and Disclaimer:**The information provided on this page represents TI's knowledge and belief as of the date that it is provided. TI bases its knowledge and belief on information provided by third parties, and makes no representation or warranty as to the accuracy of such information. Efforts are underway to better integrate information from third parties. TI has taken and continues to take reasonable steps to provide representative and accurate information but may not have conducted destructive testing or chemical analysis on incoming materials and chemicals. TI and TI suppliers consider certain information to be proprietary, and thus CAS numbers and other limited information may not be available for release.

In no event shall TI's liability arising out of such information exceed the total purchase price of the TI part(s) at issue in this document sold by TI to Customer on an annual basis.

**OTHER QUALIFIED VERSIONS OF TPS61093 :**

- Automotive: [TPS61093-Q1](#)

## NOTE: Qualified Version Definitions:

- Automotive - Q100 devices qualified for high-reliability automotive applications targeting zero defects

**TAPE AND REEL INFORMATION**

**QUADRANT ASSIGNMENTS FOR PIN 1 ORIENTATION IN TAPE**

\*All dimensions are nominal

Device	Package Type	Package Drawing	Pins	SPQ	Reel Diameter (mm)	Reel Width W1 (mm)	A0 (mm)	B0 (mm)	K0 (mm)	P1 (mm)	W (mm)	Pin1 Quadrant
TPS61093DSKR	SON	DSK	10	3000	178.0	8.4	2.8	2.8	1.1	4.0	8.0	Q2
TPS61093DSKR	SON	DSK	10	3000	180.0	8.4	2.8	2.8	1.0	4.0	8.0	Q2
TPS61093DSKT	SON	DSK	10	250	180.0	8.4	2.8	2.8	1.0	4.0	8.0	Q2
TPS61093DSKT	SON	DSK	10	250	178.0	8.4	2.75	2.75	0.95	4.0	8.0	Q2

**TAPE AND REEL BOX DIMENSIONS**

\*All dimensions are nominal

Device	Package Type	Package Drawing	Pins	SPQ	Length (mm)	Width (mm)	Height (mm)
TPS61093DSKR	SON	DSK	10	3000	205.0	200.0	33.0
TPS61093DSKR	SON	DSK	10	3000	182.0	182.0	20.0
TPS61093DSKT	SON	DSK	10	250	182.0	182.0	20.0
TPS61093DSKT	SON	DSK	10	250	205.0	200.0	33.0

DSK (S-PDSO-N10)

PLASTIC QUAD FLATPACK

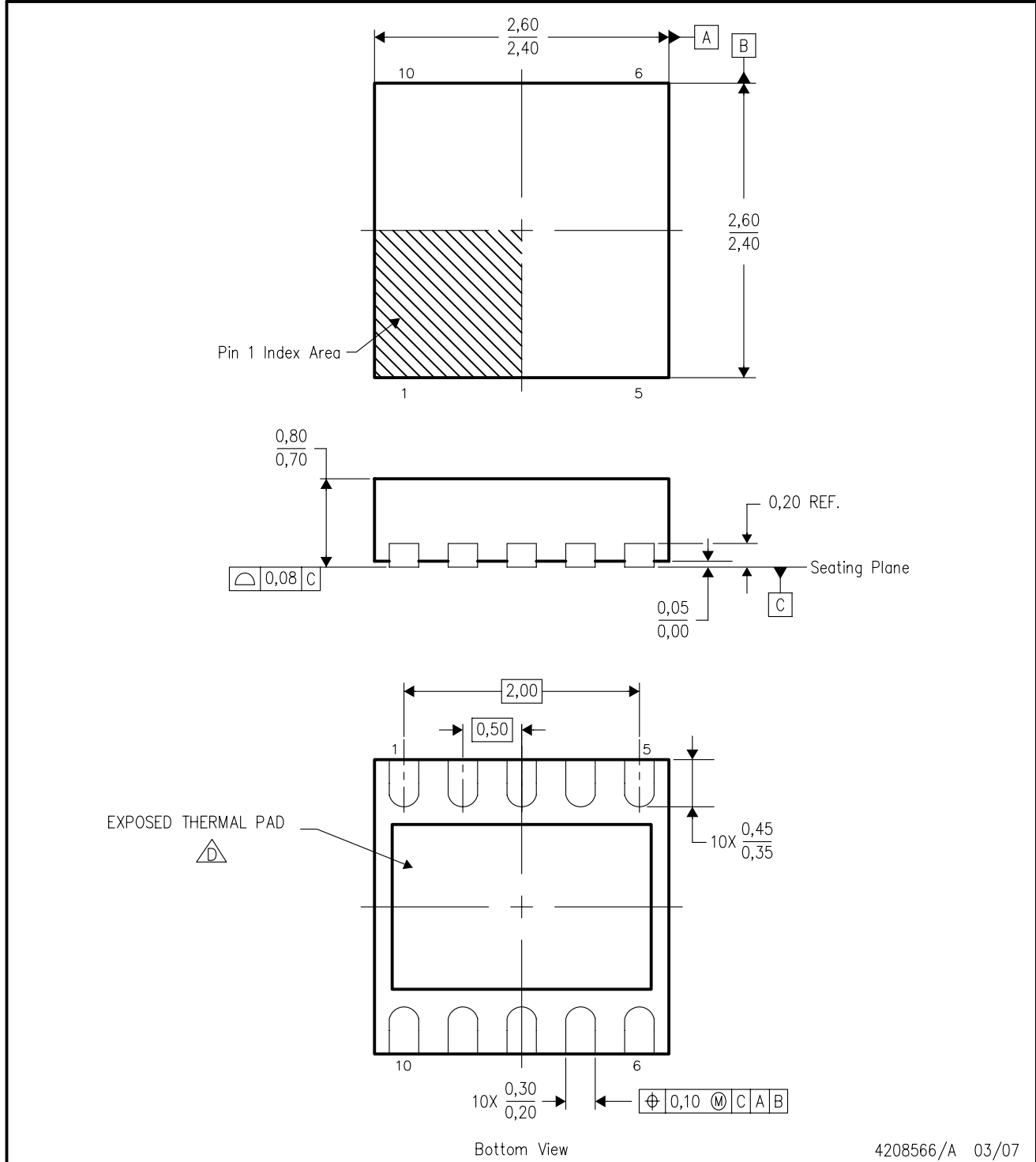

4208566/A 03/07

- NOTES:
- A. All linear dimensions are in millimeters. Dimensioning and tolerancing per ASME Y14.5M-1994.
  - B. This drawing is subject to change without notice.
  - C. Small Outline No-Lead (SON) package configuration.
  -  The package thermal pad must be soldered to the board for thermal and mechanical performance. See the Product Data Sheet for details regarding the exposed thermal pad dimensions.

## THERMAL PAD MECHANICAL DATA

DSK (R-PWSON-N10)

PLASTIC SMALL OUTLINE NO-LEAD

### THERMAL INFORMATION

This package incorporates an exposed thermal pad that is designed to be attached directly to an external heatsink. The thermal pad must be soldered directly to the printed circuit board (PCB). After soldering, the PCB can be used as a heatsink. In addition, through the use of thermal vias, the thermal pad can be attached directly to the appropriate copper plane shown in the electrical schematic for the device, or alternatively, can be attached to a special heatsink structure designed into the PCB. This design optimizes the heat transfer from the integrated circuit (IC).

For information on the Quad Flatpack No-Lead (QFN) package and its advantages, refer to Application Report, QFN/SON PCB Attachment, Texas Instruments Literature No. SLUA271. This document is available at [www.ti.com](http://www.ti.com).

The exposed thermal pad dimensions for this package are shown in the following illustration.

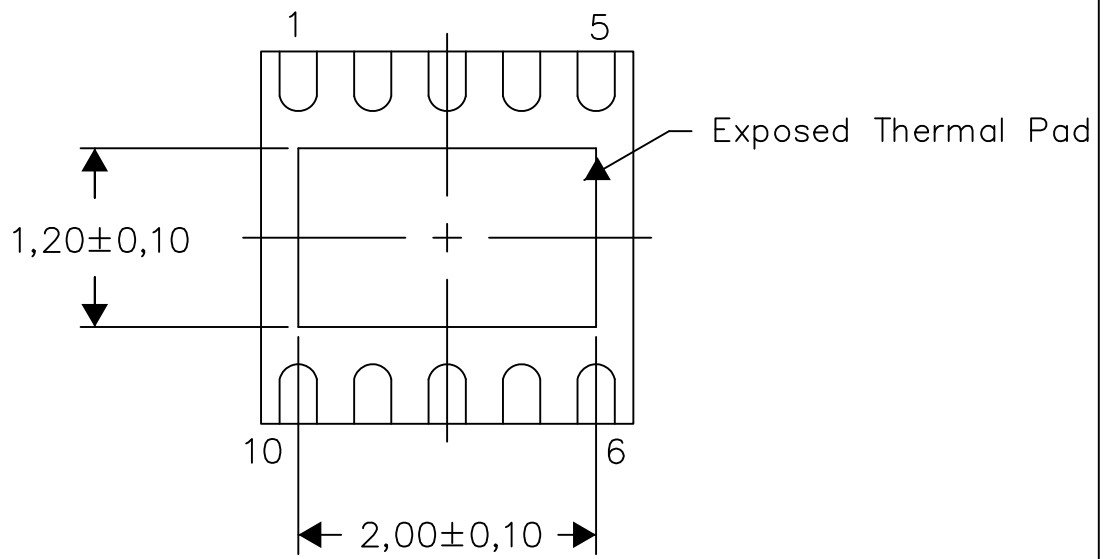

Bottom View

Exposed Thermal Pad Dimensions

4208579-2/E 12/12

NOTE: All linear dimensions are in millimeters

DSK (R-PWSON-N10)

PLASTIC SMALL OUTLINE NO-LEAD

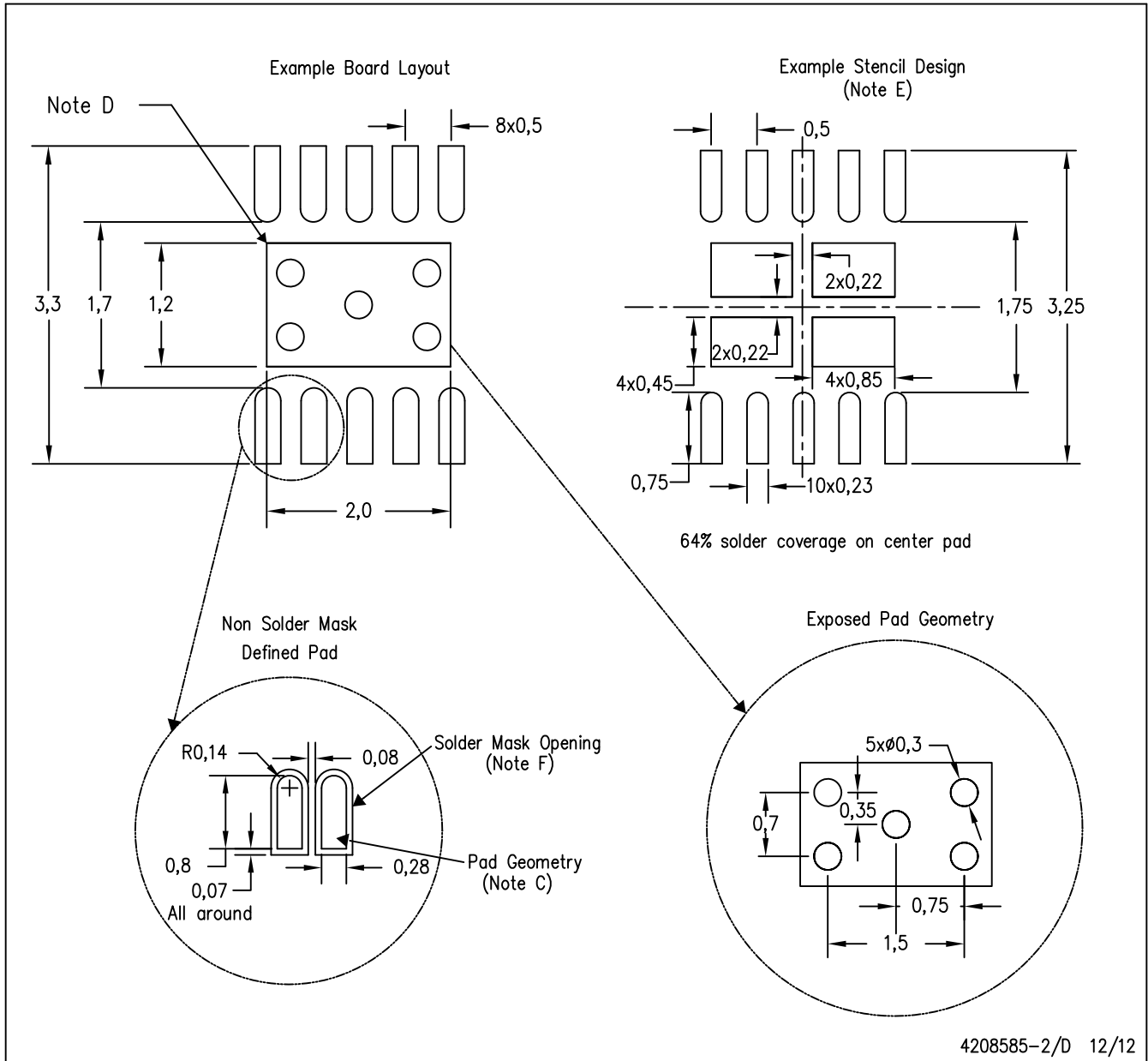

- NOTES:
- All linear dimensions are in millimeters.
  - This drawing is subject to change without notice.
  - Publication IPC-SM-782 is recommended for alternate designs.
  - This package is designed to be soldered to a thermal pad on the board. Refer to Application Note, Quad Flat-Pack Packages, Texas Instruments Literature No. SLUA271, and also the Product Data Sheets for specific thermal information, via requirements, and recommended board layout. These documents are available at [www.ti.com](http://www.ti.com) <<http://www.ti.com>>.
  - Laser cutting apertures with trapezoidal walls and also rounding corners will offer better paste release. Customers should contact their board assembly site for stencil design recommendations. Refer to IPC 7525 for stencil design considerations.
  - Customers should contact their board fabrication site for minimum solder mask web tolerances between signal pads.

## IMPORTANT NOTICE AND DISCLAIMER

TI PROVIDES TECHNICAL AND RELIABILITY DATA (INCLUDING DATASHEETS), DESIGN RESOURCES (INCLUDING REFERENCE DESIGNS), APPLICATION OR OTHER DESIGN ADVICE, WEB TOOLS, SAFETY INFORMATION, AND OTHER RESOURCES "AS IS" AND WITH ALL FAULTS, AND DISCLAIMS ALL WARRANTIES, EXPRESS AND IMPLIED, INCLUDING WITHOUT LIMITATION ANY IMPLIED WARRANTIES OF MERCHANTABILITY, FITNESS FOR A PARTICULAR PURPOSE OR NON-INFRINGEMENT OF THIRD PARTY INTELLECTUAL PROPERTY RIGHTS.

These resources are intended for skilled developers designing with TI products. You are solely responsible for (1) selecting the appropriate TI products for your application, (2) designing, validating and testing your application, and (3) ensuring your application meets applicable standards, and any other safety, security, or other requirements. These resources are subject to change without notice. TI grants you permission to use these resources only for development of an application that uses the TI products described in the resource. Other reproduction and display of these resources is prohibited. No license is granted to any other TI intellectual property right or to any third party intellectual property right. TI disclaims responsibility for, and you will fully indemnify TI and its representatives against, any claims, damages, costs, losses, and liabilities arising out of your use of these resources.

TI's products are provided subject to TI's Terms of Sale ([www.ti.com/legal/termsofsale.html](http://www.ti.com/legal/termsofsale.html)) or other applicable terms available either on [ti.com](http://ti.com) or provided in conjunction with such TI products. TI's provision of these resources does not expand or otherwise alter TI's applicable warranties or warranty disclaimers for TI products.

Mailing Address: Texas Instruments, Post Office Box 655303, Dallas, Texas 75265  
Copyright © 2019, Texas Instruments Incorporated

## Looking for pricing, stock, or lifecycle information?

Click below to explore more details on WIN SOURCE:

 [View TPS61093DSK on WIN SOURCE](#)

 [Texas Instruments](#) Information

## Optimize Your Supply Chain with WIN SOURCE Solutions

-  Global Sourcing Solution
-  Obsolete Management
-  Cost Control Management
-  Shortage Management
-  Alternative Solution
-  Excess Inventory Management