



**THE DATASHEET OF
TPS63061DSCR**



TPS6306x High Input Voltage, Buck-Boost Converter With 2-A Switch Current

1 Features

- Input voltage range: 2.5 V to 12 V
- Efficiency: Up to 93%
- Output current at 5 V ($V_{IN} < 10$ V):
2 A in buck mode
- Output current at 5 V ($V_{IN} > 4$ V):
1.3 A in boost mode
- Automatic transition between step down and boost mode
- Typical device quiescent current: $< 30 \mu\text{A}$
- Fixed and adjustable output voltage options from 2.5 V to 8 V
- Power save mode for improved efficiency at low output power
- Forced fixed-frequency operation at 2.4 MHz and synchronization possible
- Power good output
- Buck-Boost Overlap Control™
- Load disconnect during shutdown
- Overtemperature protection
- Overvoltage protection

2 Applications

- Dual Li-ion application
- Digital still cameras (DSC) and camcorders
- Notebook computer
- Industrial metering equipment
- Ultra mobile PCs and mobile internet devices
- Personal medical products
- High-power LEDs

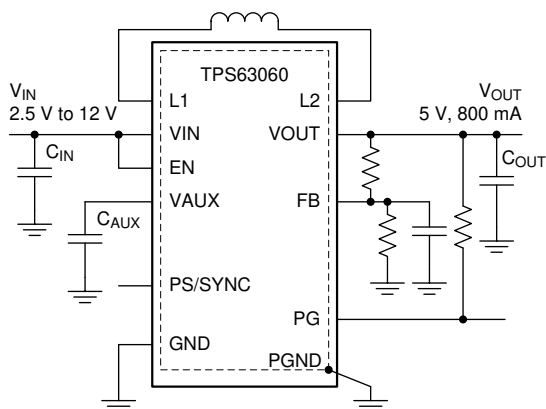

Simplified Application

3 Description

The TPS6306x devices provide a power supply solution for products powered by either three-cell up to six-cell alkaline, NiCd or NiMH battery, or a one-cell or dual-cell Li-Ion or Li-polymer battery. Output currents can go as high as 2 A while using a dual-cell Li-Ion or Li-polymer battery, and discharge to 5 V or lower. The buck-boost converter is based on a fixed frequency, pulse width modulation (PWM) controller using synchronous rectification to obtain maximum efficiency. At low load currents, the converter enters power save mode to maintain high efficiency over a wide load current range. The power save mode can be disabled, forcing the converter to operate at a fixed switching frequency. The maximum average current in the switches is limited to a typical value of 2.25 A. The output voltage is programmable using an external resistor divider, or is fixed internally on the chip. The converter can be disabled to minimize battery drain. During shutdown, the load disconnects from the battery.

The devices are available in a 3 mm × 3 mm, 10-pin, WSON (DSC) package.

Device Information (1)

PART NUMBER	PACKAGE	BODY SIZE (NOM)
TPS63060	WSON (10)	3.00 mm × 3.00 mm
TPS63061		

- (1) For all available packages, see the orderable addendum at the end of the data sheet.

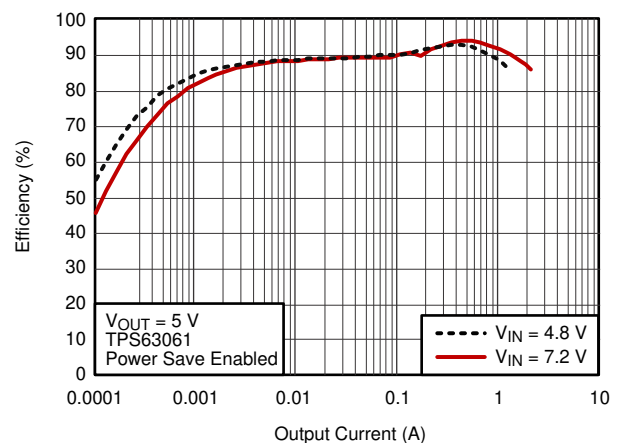

Efficiency vs Output Current



Table of Contents

1 Features	1	8.3 Feature Description.....	9
2 Applications	1	8.4 Device Functional Modes.....	10
3 Description	1	9 Application and Implementation	13
4 Revision History	2	9.1 Application Information.....	13
5 Device Comparison	3	9.2 Typical Application.....	13
6 Pin Configuration and Functions	4	10 Power Supply Recommendations	20
Pin Functions.....	4	11 Layout	21
7 Specifications	5	11.1 Layout Guidelines.....	21
7.1 Absolute Maximum Ratings.....	5	11.2 Layout Example.....	21
7.2 ESD Ratings.....	5	12 Device and Documentation Support	22
7.3 Recommended Operating Conditions.....	5	12.1 Device Support.....	22
7.4 Thermal Information.....	5	12.2 Documentation Support.....	22
7.5 Electrical Characteristics.....	6	12.3 Receiving Notification of Documentation Updates.....	22
7.6 Typical Characteristics.....	7	12.4 Community Resources.....	22
8 Detailed Description	8	12.5 Trademarks.....	22
8.1 Overview.....	8	13 Mechanical, Packaging, and Orderable Information	22
8.2 Functional Block Diagrams.....	8		

4 Revision History

Changes from Revision B (December 2014) to Revision C (September 2020)

Page

• Updated the numbering format for tables, figures, and cross-references throughout the document.....	1
• Changed <i>Application From: DSCs and Camcorders To: Digital Still Cameras (DSC) and Camcorders</i>	1
• Deleted PowerPAD™ package from the <i>Description</i>	1
• Changed the <i>Typical Application Schematic</i>	1
• Removed PACKAGE MARKING from the <i>Device Comparison Table</i>	3
• Changed From: PowerPAD™ To: Exposed Thermal Pad in the <i>Pin Functions</i> table.....	4
• Changed L1 and L2 values in the <i>Absolute Maximum Ratings</i> table.....	5
• Deleted Machine model (MM) from the <i>ESD Ratings</i> table.....	5
• Added "Thermal shutdown" and "Thermal Shutdown hysteresis" to the <i>Electrical Characteristics</i> table.....	6
• Deleted "Overtemperature protection" and "Overtemperature hysteresis" from the <i>Electrical Characteristics</i> table.....	6
• Added "Maximum reverse current" to the <i>Electrical Characteristics</i> table.....	6
• Added condition footnote to <i>Electrical Characteristics</i> table.....	6
• Changed the <i>Overview</i> section.....	8
• Changed Figure 8-1 Title From: TPS63061 Fixed Output To: TPS63060 Adjustable.....	8
• Changed Figure 8-2 Title From: TPS63060 Adjustable To: TPS63061 Fixed Output.....	8
• Split the <i>Soft-Start Function</i> and <i>Short-Circuit Protection</i> into two separate sections.....	9
• Moved <i>Synchronization</i> from the <i>Power-Save Mode</i> section into a separate section.....	11
• Changed C2 (2 x 10 μF) To: C1 (2 x 10 μF) in Figure 9-1	13
• Deleted two graphs "Output Current vs Input Voltage" and "Output Current vs Input Voltage" from the <i>Application Curves</i>	16

Changes from Revision A (February 2012) to Revision B (December 2014)

Page

• Added <i>ESD Ratings</i> table, <i>Feature Description</i> section, <i>Device Functional Modes</i> section, <i>Application and Implementation</i> section, <i>Power Supply Recommendations</i> section, <i>Layout</i> section, <i>Device and Documentation Support</i> section, and <i>Mechanical, Packaging, and Orderable Information</i> section.....	1
--	---

5 Device Comparison

Part Number ⁽²⁾ ⁽¹⁾	Output Voltage DC/DC
TPS63060DSC	Adjustable
TPS63061DSC	5 V

- (1) Contact the factory to confirm availability of other fixed-output voltage versions.
- (2) For detailed ordering information please check the *Package Option Addendum* section at the end of this data sheet.

6 Pin Configuration and Functions

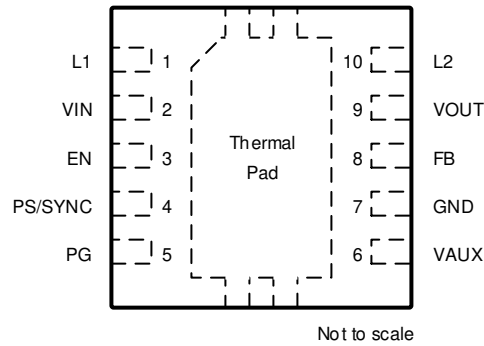

Figure 6-1. DSC Package 10 Pins (Top View)

Pin Functions

Pin		I/O	Description
Name	No.		
EN	3	I	Enable input (1 enabled, 0 disabled)
FB	8	I	Voltage feedback of adjustable versions, must be connected to VOUT on fixed output voltage versions
GND	7		Control and logic ground
L1	1	I	Connection for inductor
L2	10	I	Connection for inductor
PG	5	O	Output power good (1 good, 0 failure, open drain)
PS/SYNC	4	I	Enable / disable power save mode (1 disabled, 0 enabled, clock signal for synchronization)
VAUX	6		Connection for capacitor
VIN	2	I	Supply voltage for power stage
VOUT	9	O	Buck-boost converter output
Exposed Thermal Pad			Must be soldered to achieve the appropriate power dissipation. Must be connected to PGND.

7 Specifications

7.1 Absolute Maximum Ratings

over operating free-air temperature range (unless otherwise noted)⁽¹⁾

		MIN	MAX	UNIT
Voltage range	EN, FB, PS/SYNC, VIN, VOUT, PG, L1, L2	-0.3	17	V
	L1, L2 (AC, less than 10ns)	-5	18	V
	VAUX, FB	-0.3	7.5	V
Operating virtual junction temperature range, T _J		-40	125	°C
Storage temperature, T _{stg}		-65	150	°C

- (1) Stresses beyond those listed under *absolute maximum ratings* may cause permanent damage to the device. These are stress ratings only, and functional operation of the device at these or any other conditions beyond those indicated under *recommended operating conditions* is not implied. Exposure to absolute-maximum-rated conditions for extended periods may affect device reliability.

7.2 ESD Ratings

		VALUE	UNIT
V _(ESD)	Electrostatic discharge	Human-body model (HBM), per ANSI/ESDA/JEDEC JS-001 ⁽¹⁾	±3000
		Charged-device model (CDM), per JEDEC specification JESD22-C101 or ANSI/ESDA/JEDEC JS-002 ⁽²⁾	±1500

- (1) JEDEC document JEP155 states that 500-V HBM allows safe manufacturing with a standard ESD control process.
 (2) JEDEC document JEP157 states that 250-V CDM allows safe manufacturing with a standard ESD control process.

7.3 Recommended Operating Conditions

		MIN	MAX	UNIT
Supply voltage at VIN		2.5	12	V
Output current I _{OUT} ⁽¹⁾			1	A
Operating free air temperature range, T _A		-40	85	°C
Operating virtual junction temperature range, T _J		-40	125	°C

- (1) $10 \leq V_{IN} \leq 12$ V

7.4 Thermal Information

THERMAL METRIC ⁽¹⁾		TPS63060 TPS63061	UNIT
		DSC	
		10 PINS	
R _{θJA}	Junction-to-ambient thermal resistance	48.7	°C/W
R _{θJC(top)}	Junction-to-case (top) thermal resistance	54.8	
R _{θJB}	Junction-to-board thermal resistance	19.8	
ψ _{JT}	Junction-to-top characterization parameter	1.1	
ψ _{JB}	Junction-to-board characterization parameter	19.6	
R _{θJC(bot)}	Junction-to-case (bottom) thermal resistance	4.2	

- (1) For more information about traditional and new thermal metrics, see the [Semiconductor and IC Package Thermal Metrics](#) application report.

7.5 Electrical Characteristics

 Over operating free-air temperature range (unless otherwise noted) $T_A = 25^\circ\text{C}$

PARAMETER		TEST CONDITIONS	MIN	TYP	MAX	UNIT	
DC/DC STAGE							
V_{IN}	Input voltage range		2.5		12	V	
V_{IIN}	Minimum input voltage for startup				2.5	V	
V_{OUT}	Output voltage		TPS63060	2.5	8	V	
		$V_{PS/SYNC} = \text{GND}$ referenced to 5 V	TPS63061	0.6%	5%		
D_{MIN}	Minimum duty-cycle in step down conversion			10%	20%		
I_{OUT}	Output current at 5V in buck mode	$V_{IN} < 10\text{ V}$		2		A	
	Output current at 5V in boost mode	$V_{IN} > 4\text{ V}$		1.3		A	
V_{FB}	Feedback voltage	$V_{PS/SYNC} = V_{IN}$	TPS63060	495	500	505	mV
		$V_{PS/SYNC} = \text{GND}$ referenced to 500 mV		0.6%		5%	
f_{OSC}	Oscillator frequency		2200	2400	2600	kHz	
	Frequency range for synchronization		2200	2400	2600	kHz	
I_{SW}	Average inductance current limit	$V_{IN} = 5\text{ V}$	2000	2250	2500	mA	
$R_{DS(on)H}$	High-side MOSFET on-resistance	$V_{IN} = 5\text{ V}$		90		m Ω	
$R_{DS(on)L}$	Low-side switch MOSFET on-resistance	$V_{IN} = 5\text{ V}$		95		m Ω	
	Line regulation	Power save mode disabled		0.5%			
	Load regulation	Power save mode disabled		0.5%			
I_Q	Input voltage quiescent current	$I_{OUT} = 0\text{ mA}$, $V_{EN} = V_{IN} = 5\text{ V}$, $V_{OUT} = 5\text{ V}$		30	60	μA	
I_Q	Output voltage quiescent current			7	15	μA	
R_{FB}	FB input impedance	$V_{EN} = \text{HIGH}$	TPS63061	1.5		M Ω	
I_S	Shutdown current	$V_{EN} = 0\text{ V}$, $V_{IN} = 5\text{ V}$		0.3	2	μA	
CONTROL STAGE							
V_{AUX}	Maximum bias voltage	$V_{IN} > V_{OUT}$		V_{IN}	7	V	
		$V_{IN} < V_{OUT}$		V_{OUT}	7	V	
I_{AUX}	Load current at V_{AUX}				1	mA	
UVLO	Under voltage lockout threshold	V_{IN} falling	1.8	1.9	2.2	V	
	Under voltage lockout hysteresis			300		mV	
	Thermal shutdown	Temperature rising		140		$^\circ\text{C}$	
	Thermal Shutdown hysteresis			20		$^\circ\text{C}$	
V_{IL}	EN, PS/SYNC input low voltage				0.4	V	
V_{IH}	EN, PS/SYNC input high voltage		1.2			V	
	EN, PS/SYNC input current	Clamped on GND or V_{IN}		0.01	0.1	μA	
	PG output low voltage	$V_{OUT} = 5\text{ V}$, $I_{PGL} = 10\text{ }\mu\text{A}$		0.04	0.4	V	
	PG output leakage current			0.01	0.1	μA	
	Output overvoltage protection		12		16	V	
I_{lim_neg}	Maximum reverse current	$V_{IN} = 5\text{ V}$			900	mA	
t_{trans}	Time from PS/SYNC pin going low to start operating in PFM ⁽¹⁾			4.8	10	μs	

(1) Specified by design. Not production tested.

7.6 Typical Characteristics

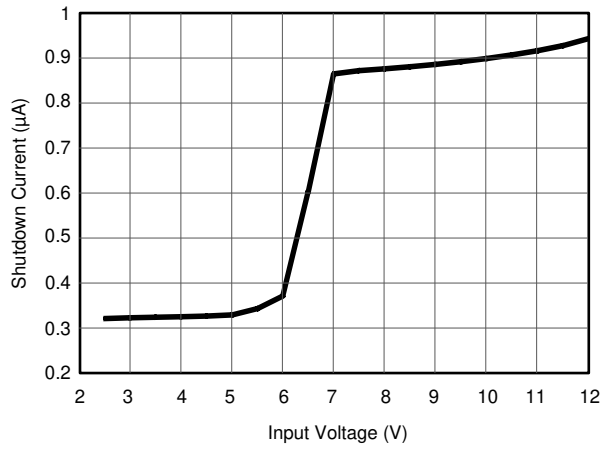

Figure 7-1. Shutdown Current vs Input Voltage

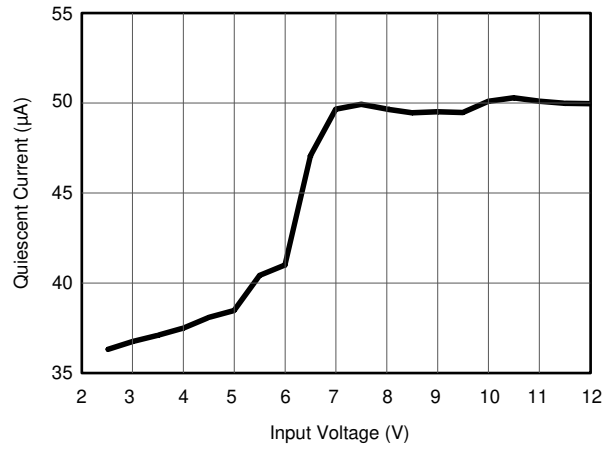

Figure 7-2. Quiescent Current vs Input Voltage

8 Detailed Description

8.1 Overview

The TPS6306x use 4 internal N-channel MOSFETs to maintain synchronous power conversion at all possible operating conditions. This enables the device to keep high efficiency over the complete input voltage and output power range. To regulate the output voltage at all possible input voltage conditions, the device automatically switches from buck operation to boost operation and back as required by the configuration. It always uses one active switch, one rectifying switch, one switch is held on, and one switch held off. Therefore, it operates as a buck converter when the input voltage is higher than the output voltage, and as a boost converter when the input voltage is lower than the output voltage. There is no mode of operation in which all 4 switches are switching at the same time. Keeping one switch on and one switch off eliminates their switching losses. The RMS current through the switches and the inductor is kept at a minimum, to minimize switching and conduction losses. Controlling the switches this way allows the converter to always keep higher efficiency.

The device provides a seamless transition from buck to boost or from boost to buck operation.

8.2 Functional Block Diagrams

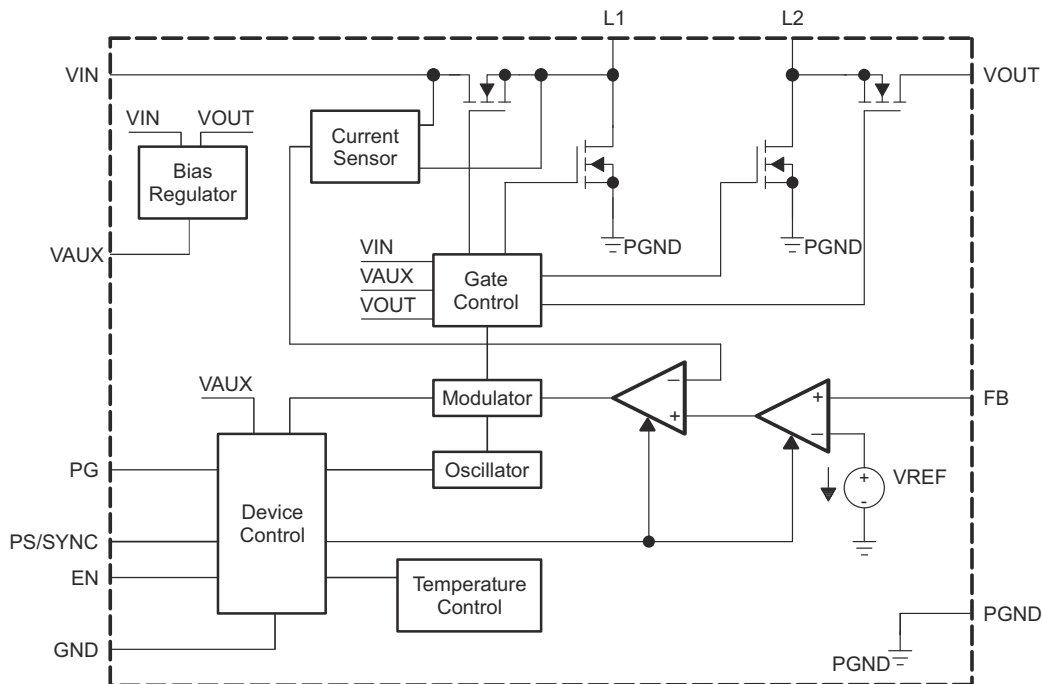

Figure 8-1. TPS63060 Adjustable

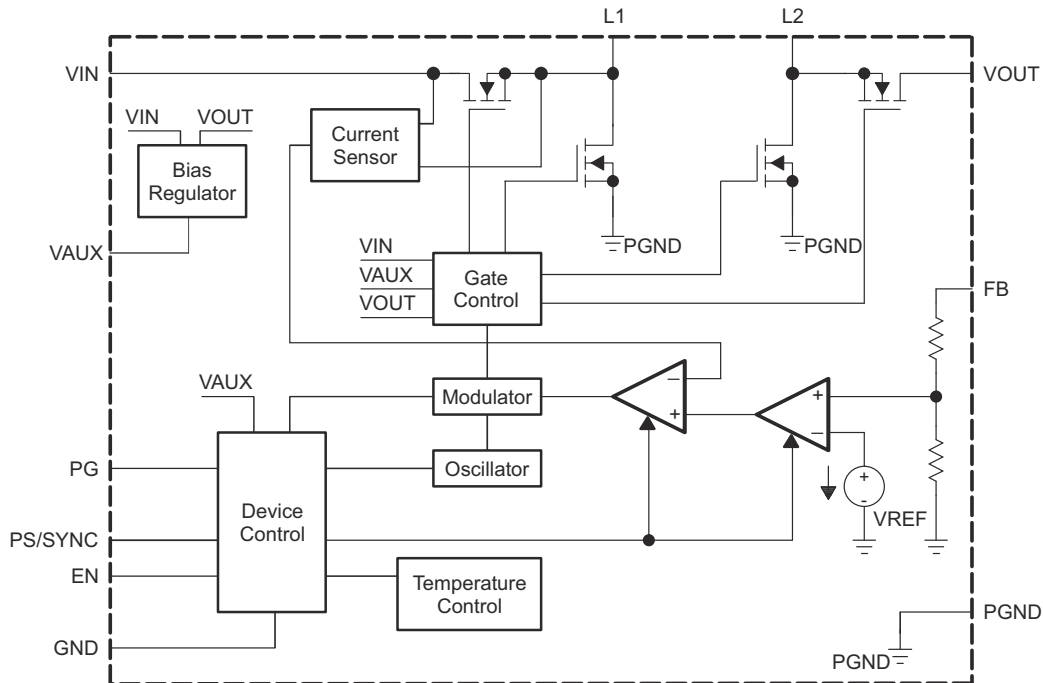

Figure 8-2. TPS63061 Fixed Output

8.3 Feature Description

8.3.1 Power Good

The device has a built in power good function to indicate whether the output voltage is regulated properly. As soon as the average inductor current gets limited to a value below the current the voltage regulator demands for maintaining the output voltage the power good output gets low impedance. The output is open drain, so its logic function can be adjusted to any voltage level the connected logic is using, by connecting a pull up resistor to the supply voltage of the logic. By monitoring the status of the current control loop, the power good output provides the earliest indication possible for an output voltage break down and leaves the connected application a maximum time to safely react.

8.3.2 Soft-Start Function

After being enabled, the device starts operating. The average current limit ramps up from an initial 400 mA following the output voltage increasing. At an output voltage of about 1.2 V, the current limit is at its nominal value. If the output voltage does not increase, the current limit does not increase. The device implements no timer. Thus, the output voltage overshoot at startup, as well as the inrush current, remains at a minimum. The device ramps up the output voltage in a controlled manner even if a large capacitor is connected at the output.

8.3.3 Short-Circuit Protection

When the output voltage does not increase above 1.2 V, the device assumes a short circuit at the output, and keeps the current limit low to protect itself and the application. During a short-circuit situation on the output, the device maintains the current limit below 2 A typically (minimum average inductance current).

8.3.4 Overvoltage Protection

If, for any reason, the output voltage is not fed back properly to the input of the voltage amplifier, control of the output voltage no longer works. Therefore, overvoltage protection is implemented to avoid the output voltage exceeding critical values for the device and possibly for the system it supplies. The implemented overvoltage protection circuit monitors the output voltage internally as well. If it reaches the overvoltage threshold, the voltage amplifier regulates the output voltage to this value.

8.3.5 Undervoltage Lockout

An undervoltage lockout function prevents device start-up if the supply voltage on VIN is lower than approximately its threshold (see the [Section 7.5](#) table). When in operation, the device automatically enters the shutdown mode if the voltage on VIN drops below the undervoltage lockout threshold. The device automatically restarts if the input voltage recovers to the minimum operating input voltage.

8.3.6 Overtemperature Protection

The device has a built-in temperature sensor which monitors the internal device temperature. If the temperature exceeds the programmed threshold (see the [Section 7.5](#) table) the device stops operating. As soon as the device temperature has decreased below the programmed threshold, it starts operating again. There is a built-in hysteresis to avoid unstable operation at device temperatures at the overtemperature threshold.

8.4 Device Functional Modes

8.4.1 Buck-Boost Operation

To regulate the output voltage at all possible input voltage conditions, the device automatically switches from buck operation to boost operation and back as required. It always uses one active switch, one rectifying switch, one switch permanently on, and one switch permanently off. Therefore, it operates as a step down converter (buck) when the input voltage is higher than the output voltage, and as a boost converter when the input voltage is lower than the output voltage. There is no mode of operation in which all 4 switches are permanently switching. Controlling the switches this way allows the converter to maintain high efficiency at the most important point of operation, when the input voltage is close to the output voltage. The RMS current through the switches and the inductor is kept at a minimum, to minimize switching and conduction losses.

8.4.2 Control Loop

The controller circuit of the device is based on an average current mode topology. The average inductor current is regulated by a fast current regulator loop which is controlled by a voltage control loop. [Figure 8-3](#) shows the control loop.

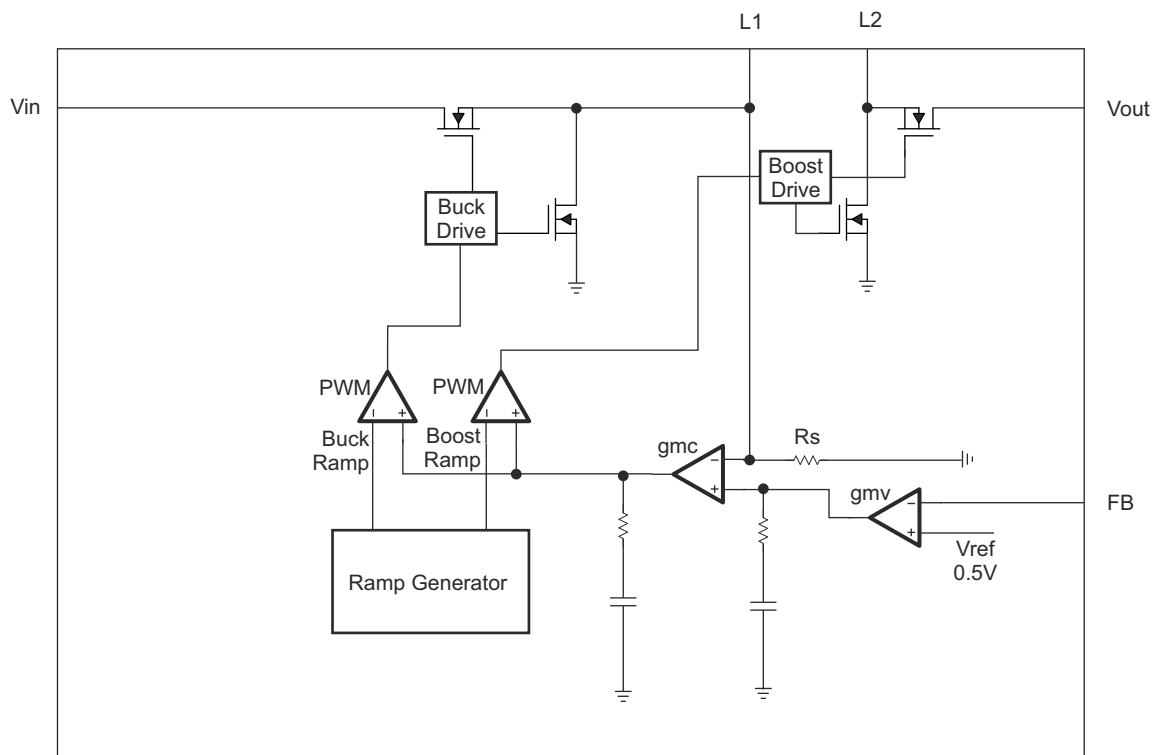

Figure 8-3. Average Current Mode Control

The non inverting input of the transconductance amplifier, g_{MV} , is assumed to be constant. The output of g_{MV} defines the average inductor current. The inductor current is reconstructed by measuring the current through the high side buck MOSFET. This current corresponds exactly to the inductor current in boost mode. In buck mode the current is measured during the on time of the same MOSFET. During the off time, the current is reconstructed internally starting from the peak value at the end of the on-time cycle. The average current is compared to the desired value and the difference, or current error, is amplified and compared to the buck or the boost sawtooth ramp. Depending on which of the two ramps the g_{MC} amplified output crosses, the device activates either the buck MOSFETs or the boost MOSFETs. When the input voltage is close to the output voltage, one boost cycle always follows a buck cycle. In this condition, no more than three cycles in a row of the same mode are allowed. This control method in the buck-boost region ensures a robust control and the highest efficiency.

8.4.3 Power-Save Mode

The PS/SYNC pin can be used to select different operation modes. Power save mode improves efficiency at light load. To enable power save mode, PS/SYNC must be set low. The device enters power save mode when the average inductor current falls to a level lower than approximately 100 mA. In that situation, the converter operates with reduced switching frequency and with a minimum quiescent current to maintain high efficiency.

During the power save mode operation, the output voltage is monitored with a comparator by the threshold comparator low and comparator high. When the device enters power save mode, the converter stops operating and the output voltage drops. The slope of the output voltage depends on the load and the value of output capacitance. As the output voltage falls below the comparator low threshold set to 2.5% typical above the output voltage, the device ramps up the output voltage again, by starting operation using a programmed average inductor current higher than required by the current load condition. Operation can last for one or several pulses. The converter continues these pulses until the comparator high threshold, set to typically 3.5% above the nominal output voltage, is reached and the average inductor current gets lower than about 100 mA. When the load increases above the minimum forced inductor current of about 100 mA, the device automatically switches to PWM mode.

The power save mode can be disabled by programming the PS/SYNC high.

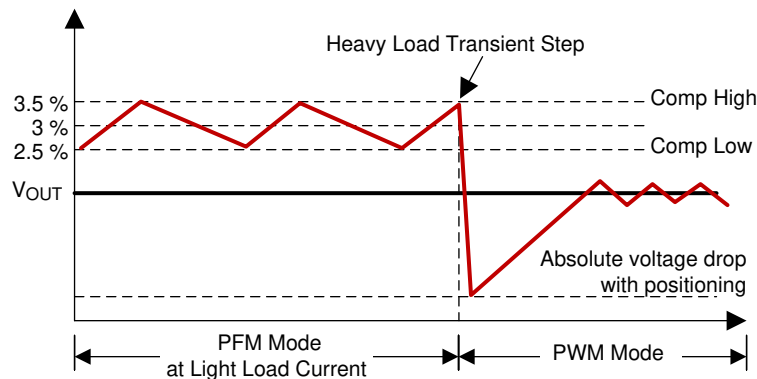

Figure 8-4. Power-Save Mode Thresholds and Dynamic Voltage Positioning

8.4.4 Synchronization

Connecting a clock signal at PS/SYNC forces the device to synchronize to the connected clock frequency.

Synchronization is done by a PLL to lower and higher frequencies compared to the internal clock. The PLL can also tolerate missing clock pulses without the converter malfunctioning. The PS/SYNC input supports standard logic thresholds.

8.4.5 Dynamic Voltage Positioning

The output voltage is typically 3% above the nominal output voltage at light-load currents, as the device is operating in power save mode. This operation mode allows additional headroom for the voltage drop during a load transient from light load to full load. This additional headroom allows the converter to operate with a small

output capacitor and maintain a low absolute voltage drop during heavy load transient changes. See [Figure 8-4](#) for detailed operation of the power save mode operation.

8.4.6 Dynamic Current Limit

The dynamic current limit function maintains the output voltage regulation when the power source becomes weaker. The maximum current allowed through the switch depends on the voltage applied at the input terminal of the TPS6306x devices. [Figure 8-5](#) shows this dependency, and the I_{SW} vs V_{IN} . The dynamic current limit has its lowest value when reaching the minimum recommended supply voltage at V_{IN} .

Given the I_{SW} value from [Figure 8-5](#), is then possible to calculate the output current reached in boost mode using [Equation 1](#) and [Equation 2](#) and in buck mode using [Equation 3](#) and [Equation 4](#).

$$\text{Duty Cycle Boost} \quad D = \frac{V_{OUT} - V_{IN}}{V_{OUT}} \quad (1)$$

$$\text{Maximum Output Current Boost} \quad I_{OUT} = \eta \times I_{SW} \times (1 - D) \quad (2)$$

$$\text{Duty Cycle Buck} \quad D = \frac{V_{OUT}}{V_{IN}} \quad (3)$$

$$\text{Maximum Output Current Buck} \quad I_{OUT} = I_{SW} \quad (4)$$

where

- η is the estimated converter efficiency (use the number from the efficiency curves or 0.80 as an assumption)
- f is the converter switching frequency (typical 2.4 MHz)
- L is the selected inductor value

If the die temperature increases above the recommended maximum temperature, the dynamic current limit becomes active. The current limit is reduced with temperature increasing.

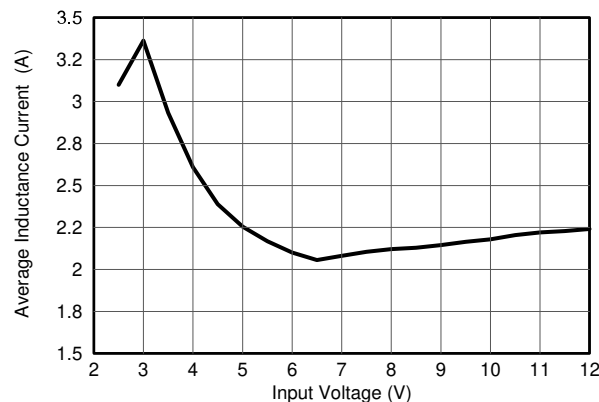

Figure 8-5. Average Inductance Current vs Input Voltage

8.4.7 Device Enable

The device operates when EN is set high. The device enters a shutdown sequence when EN is set to GND. During the shutdown sequence, the regulator stops switching, all internal control circuitry is switched off, and the load is disconnected from the input. It is possible for the output voltage to drop below the input voltage during shutdown. During the start-up sequence, the device limits the duty cycle and the peak current in order to avoid high peak currents flowing from the input.

9 Application and Implementation

Note

Information in the following applications sections is not part of the TI component specification, and TI does not warrant its accuracy or completeness. TI's customers are responsible for determining suitability of components for their purposes. Customers should validate and test their design implementation to confirm system functionality.

9.1 Application Information

The TPS6306x devices provide a power supply solution for products powered by either three-cell up to six-cell alkaline, NiCd or NiMH battery, or a one-cell or dual-cell Li-Ion or Li-polymer battery. Output currents can go as high as 2-A while using a dual-cell Li-Ion or Li-polymer battery, and discharge it down to 5 V or lower.

9.2 Typical Application

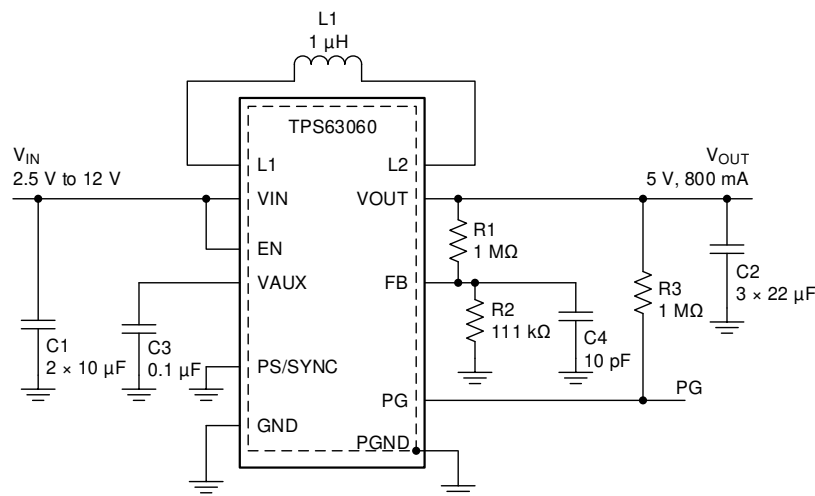

Figure 9-1. 5-V Adjustable Buck-Boost Converter Application

9.2.1 Design Requirements

The design guideline provides a component selection to operate the device within the recommended operating conditions. [Table 9-1](#) lists the components used in this application.

Table 9-1. Components for Application Characteristic Curves

Reference	Description	Manufacturer ⁽¹⁾
	TPS63060 and TPS63061	Texas Instruments
L1	1 μH, 3 mm x 3 mm x 1.5 mm	Coilcraft , XFL4020-102
C1	2 × 10 μF 16V, 0805, X5R ceramic	Taiyo Yuden, EMK212BJ
C2	3 × 22 μF 16V, 0805, X5R ceramic	Taiyo Yuden, LMK212BJ
C3	0.1 μF, X5R ceramic	
C4	10 pF, ceramic	
R1, R2	Depending on the output voltage at TPS63060 and TPS63061: R1=0, C4 and R2 n.a.	

(1) See [Section 12.1](#)

9.2.2 Detailed Design Procedure

The first step is the selection of the output filter components. To simplify this process, use [Table 9-2](#) to compare inductor and capacitor value combinations.

9.2.2.1 Step One: Output Filter Design

Table 9-2. Output Capacitor and Inductor Combinations

Inductor Value [μH] ⁽¹⁾	Output Capacitor Value [μF] ⁽²⁾		
	44	66	100
1.0	√	√ ⁽³⁾	√
1.5	√	√	√

- (1) Inductor tolerance and current de-rating is anticipated. The effective inductance can vary by 20% and –30%.
- (2) Capacitance tolerance and bias voltage de-rating is anticipated. The effective capacitance can vary by 20% and –50%.
- (3) Typical application. Other check mark indicates recommended filter combinations

9.2.2.2 Step Two: Inductor Selection

The inductor selection is affected by several parameters including inductor ripple current, output voltage ripple, transition point into power-save mode, and efficiency. See [Table 9-3](#) for typical inductors.

Table 9-3. List of Recommended Inductors

Inductor Value (μH)	Component Supplier ⁽¹⁾	Size (L×W×H) (mm)	Current Saturation (I_{SAT}) (A)	DCR (m Ω)
1	Coilcraft XFL4020-102	4 × 4 × 2.1	5.1	10.8
1	TOKO DEM2815 1226AS-H-1R0N	3 × 3.2 × 1.5	2.7	27
1.5	Coilcraft XFL4020-152	4 × 4 × 2.1	4.4	14.4

- (1) See [Section 12.1](#)

For high efficiencies, the inductor should have a low dc resistance to minimize conduction losses. Especially at high-switching frequencies the core material has a higher impact on efficiency. When using small chip inductors, the efficiency is reduced mainly due to higher inductor core losses. This needs to be considered when selecting the appropriate inductor. The inductor value determines the inductor ripple current. The larger the inductor value, the smaller the inductor ripple current and the lower the conduction losses of the converter. Conversely, larger inductor values cause a slower load transient response. To avoid saturation of the inductor, with the chosen inductance value, the peak current for the inductor in steady state operation can be calculated. [Equation 1](#) and [Equation 5](#) show how to calculate the peak current I_{PEAK} . Only the equation which defines the switch current in boost mode is reported because this is providing the highest value of current and represents the critical current value for selecting the right inductor.

$$I_{\text{PEAK}} = \frac{I_{\text{OUT}}}{\eta \times (1-D)} + \frac{V_{\text{IN}} \times D}{2 \times f_{\text{SW}} \times L} \quad (5)$$

where

- D is the duty cycle during boost mode operation
- f_{SW} is the converter switching frequency (typical 2.4 MHz)
- L is the selected inductor value
- η is the estimated converter efficiency (use the number from the efficiency curves or 0.80 as an assumption)
- The calculation must be done for the minimum input voltage which is possible to have in boost mode

Calculating the maximum inductor current using the actual operating conditions gives the minimum saturation current of the inductor needed. It's recommended to choose an inductor with a saturation current 20% higher than the value calculated using [Equation 5](#). Possible inductors are listed in [Table 9-3](#).

9.2.2.3 Step Three: Capacitor Selection

9.2.2.3.1 Input Capacitors

To improve transient behavior of the regulator and EMI behavior of the total power supply circuit, this design suggests a minimum input capacitance of 20 μF . Place a ceramic capacitor placed as close as possible to the VIN and PGND pins of the device.

9.2.2.3.2 Output Capacitor

For the output capacitor, use of a small ceramic capacitor placed as close as possible to the VOUT and PGND pins of the device is recommended. If, for any reason, the application requires the use of large capacitors which can not be placed close to the device, use a smaller ceramic capacitor in parallel to the large capacitor. The small capacitor should be placed as close as possible to the VOUT and PGND pins of the device. The recommended typical output capacitor value is 66 μF with a variance as outlined in [Table 9-1](#).

There is also no upper limit for the output capacitance value. Larger capacitors cause lower output voltage ripple as well as lower output voltage drop during load transients.

When choosing input and output capacitors, it needs to be kept in mind, that the value of capacitance experiences significant losses from their rated value depending on the operating temperature and the operating DC voltage. It is not uncommon for a small surface mount ceramic capacitor to lose 50% and more of its rated capacitance. For this reason, it is important to use a larger value of capacitance or a capacitor with higher voltage rating in order to ensure the required capacitance at the full operating voltage.

9.2.2.3.3 Bypass Capacitor

To make sure that the internal control circuits are supplied with a stable low noise supply voltage, a capacitor is connected between VAUX and GND. Using a ceramic capacitor with a value of 0.1 μF is recommended. The capacitor needs to be placed close to the VAUX pin. The value of this capacitor should not be higher than 0.22 μF .

9.2.2.4 Step Four: Setting the Output Voltage

When the adjustable output voltage version TPS63060 is used, the output voltage is set by the external resistor divider. The resistor divider must be connected between VOUT, FB and GND. When the output voltage is regulated properly, the typical value of the voltage at the FB pin is 500mV. The maximum recommended value for the output voltage is 8V. The current through the resistive divider should be about 100 times greater than the current into the FB pin. The typical current into the FB pin is 0.01 μA , and the voltage across the resistor between FB and GND, R_2 , is typically 500 mV. Based on these two values, the recommended value for R_2 should be lower than 500 $\text{k}\Omega$, in order to set the divider current at 3 μA or higher. It is recommended to keep the value for this resistor in the range of 200 $\text{k}\Omega$. From that, the value of the resistor connected between the VOUT pin and the FB pin, (R_1) depending on the needed output voltage can be calculated using [Equation 6](#).

$$R_1 = R_2 \times \left(\frac{V_{\text{OUT}}}{V_{\text{FB}}} - 1 \right) \tag{6}$$

Place a small capacitor (C_4 , 10 pF) in parallel with R_2 when using the power save mode and the adjustable version, to provide filtering and improve the efficiency at light load.

9.2.3 Application Curves

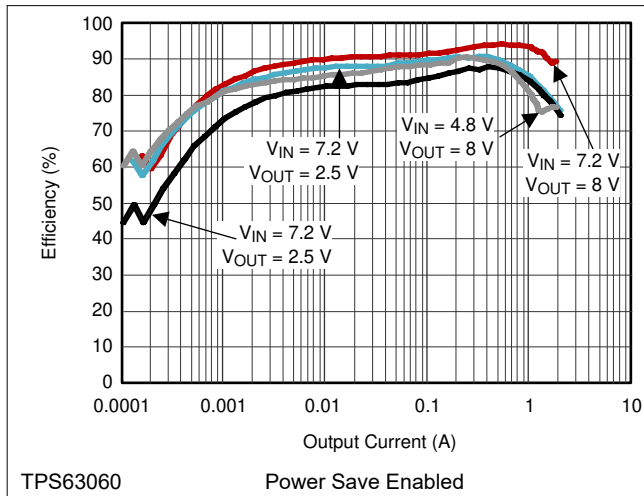

Figure 9-2. Efficiency vs. Output Current

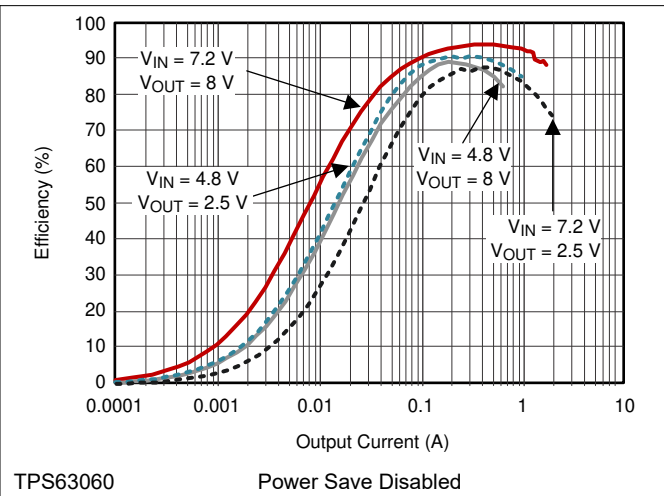

Figure 9-3. Efficiency vs. Output Current

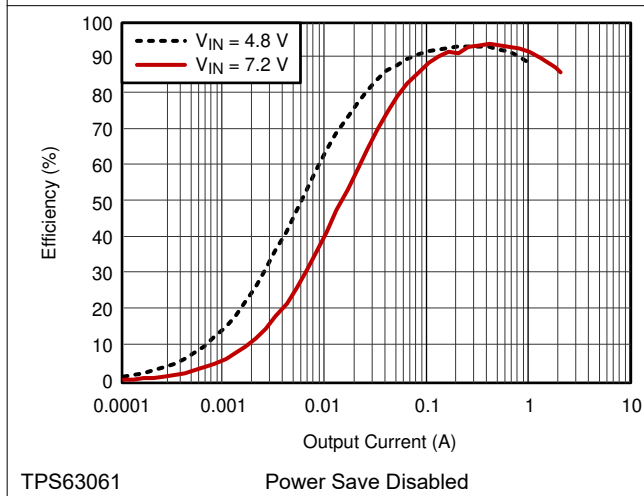

Figure 9-4. Efficiency vs. Output Current

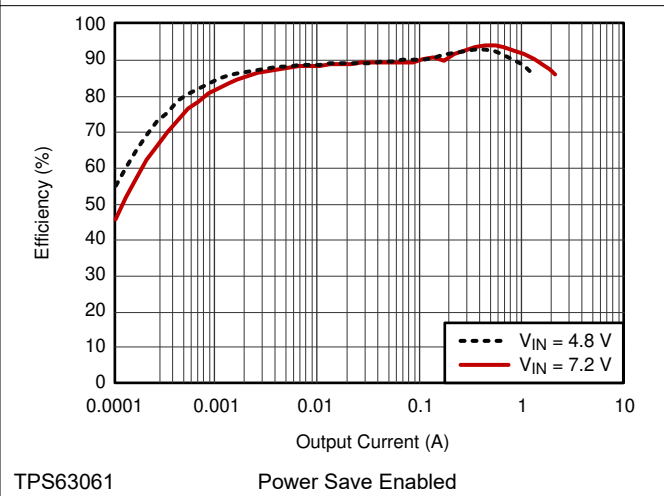
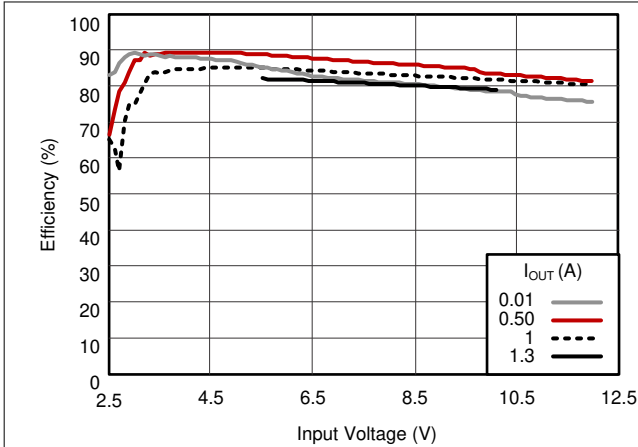
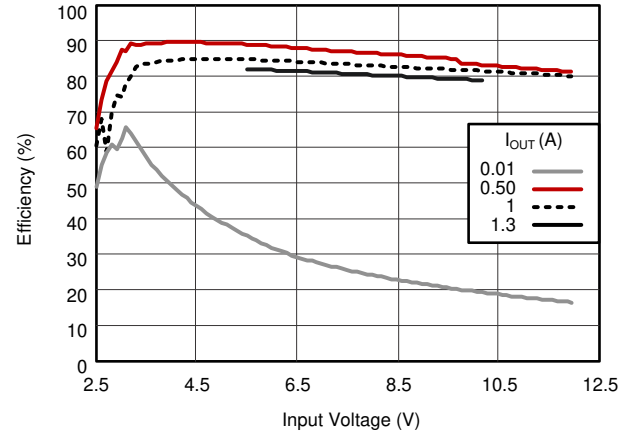

Figure 9-5. Efficiency vs. Output Current



TPS63060 Power Save Enabled
 $V_{OUT} = 2.5\text{ V}$

Figure 9-6. Efficiency vs. Input Voltage



TPS63060 Power Save Disabled
 $V_{OUT} = 2.5\text{ V}$

Figure 9-7. Efficiency vs. Input Voltage

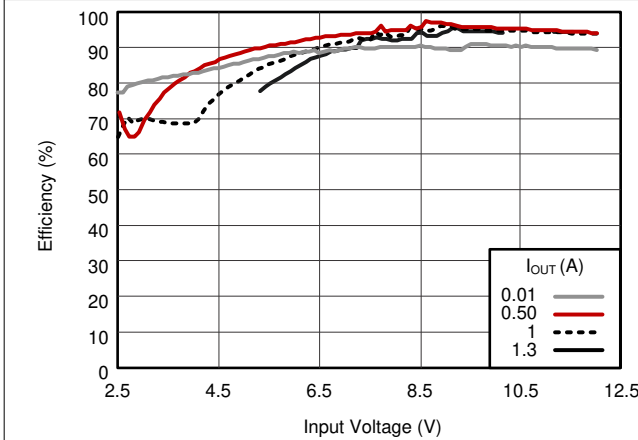

TPS63060 Power Save Enabled
 $V_{OUT} = 8\text{ V}$

Figure 9-8. Efficiency vs. Input Voltage

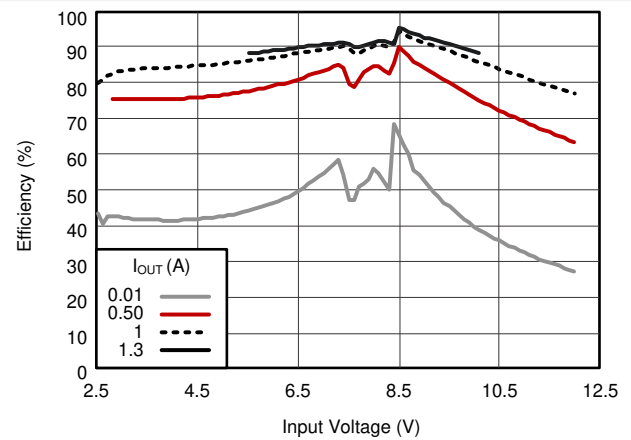

TPS63060 Power Save Disabled
 $V_{OUT} = 8\text{ V}$

Figure 9-9. Efficiency vs. Input Voltage

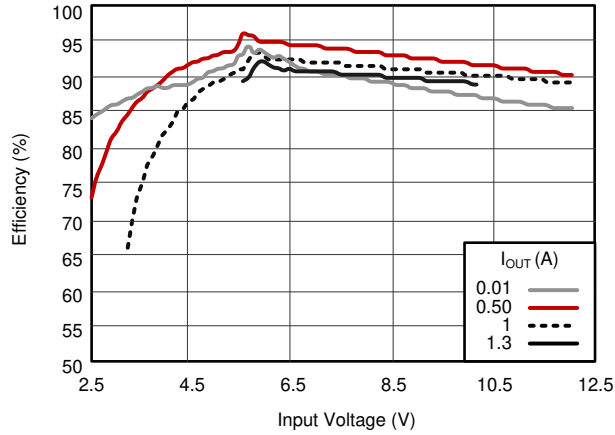

TPS63061 Power Save Enabled
 $V_{OUT} = 5\text{ V}$

Figure 9-10. Efficiency vs. Input Voltage

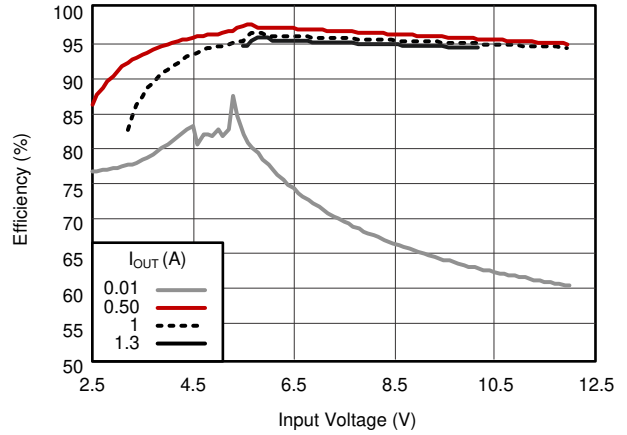

TPS63061 Power Save Disabled
 $V_{OUT} = 5\text{ V}$

Figure 9-11. Efficiency vs. Input Voltage

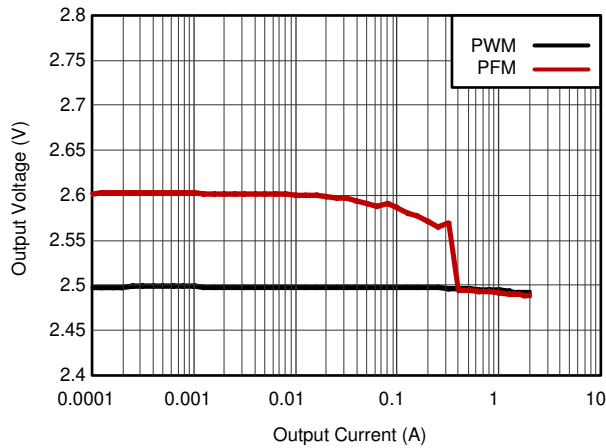

TPS63060 Power Save Disabled
 $V_{OUT} = 2.5\text{ V}$ $V_{IN} = 7.2\text{ V}$

Figure 9-12. Output Voltage vs Output Current

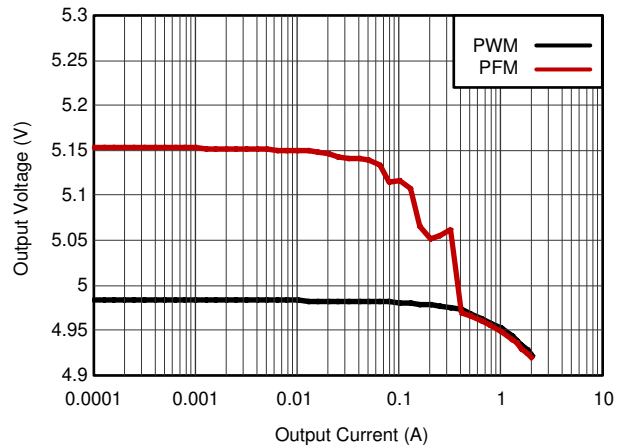

TPS63061
 $V_{IN} = 7.2\text{ V}$

Figure 9-13. Output Voltage vs Output Current

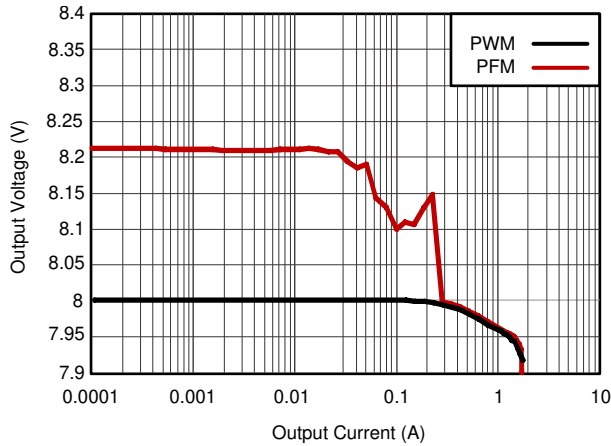

TPS63060
 $V_{OUT} = 8\text{ V}$ $V_{IN} = 7.2\text{ V}$

Figure 9-14. Output Voltage vs Output Current

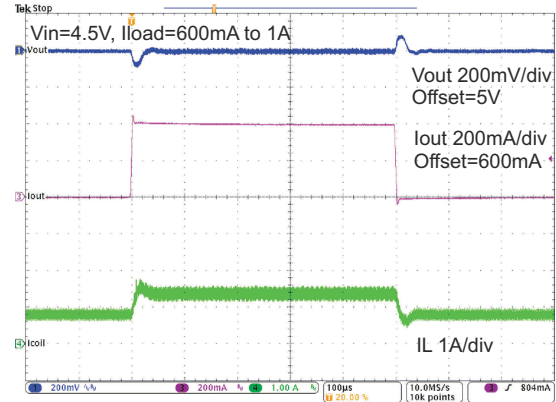

TPS63061, $V_o=5\text{V}$ 100us/div

Figure 9-15. Load Transient Response

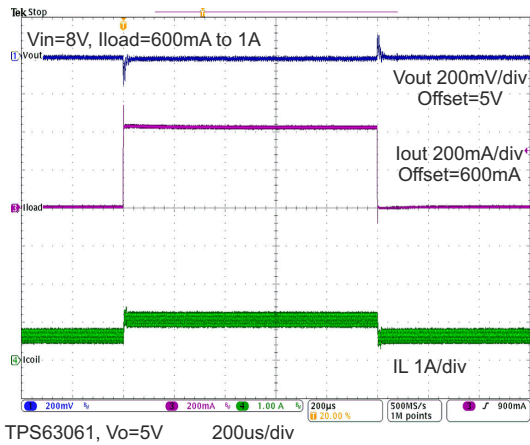

TPS63061, $V_o=5\text{V}$ 200us/div

Figure 9-16. Load Transient Response

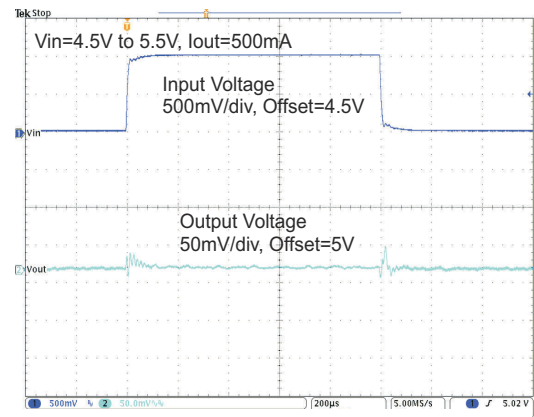

TPS63061, $V_o=5\text{V}$ 200us/div

Figure 9-17. Line Transient Response

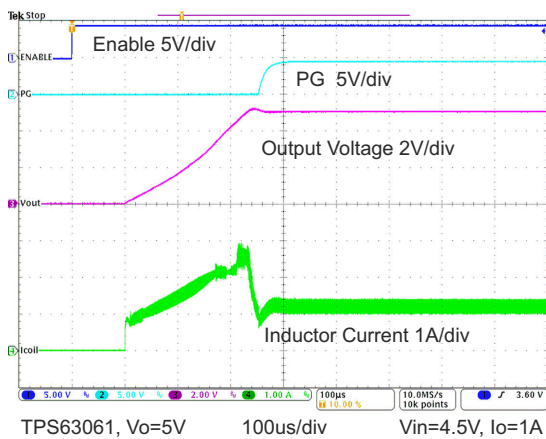

TPS63061, $V_o=5\text{V}$ 100us/div $V_{in}=4.5\text{V}$, $I_o=1\text{A}$

Figure 9-18. Startup After Enable

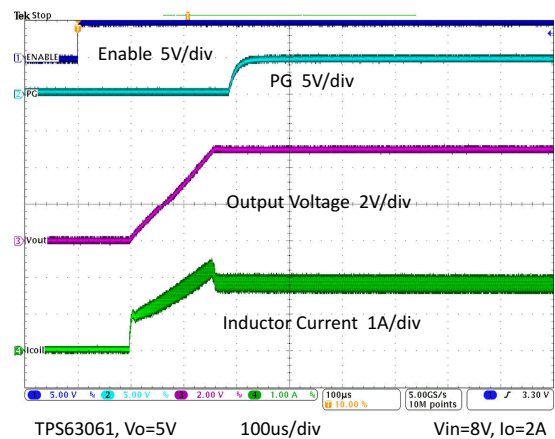

TPS63061, $V_o=5\text{V}$ 100us/div $V_{in}=8\text{V}$, $I_o=2\text{A}$

Figure 9-19. Startup After Enable

TPS63060, TPS63061

SLVSA92C – NOVEMBER 2011 – REVISED SEPTEMBER 2020

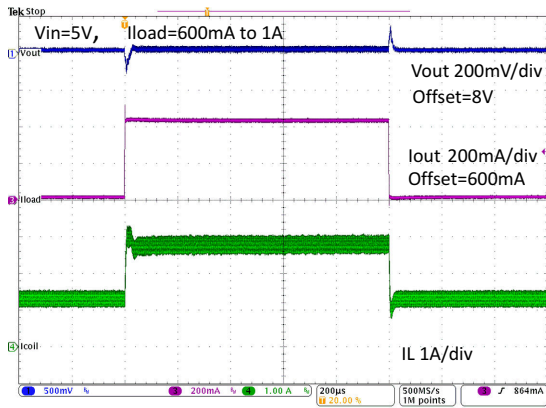

Figure 9-20. Load Transient

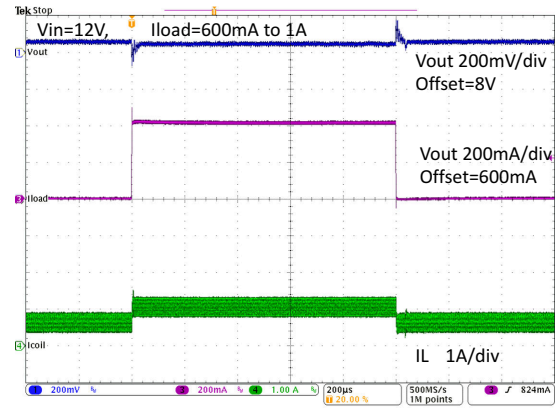

Figure 9-21. Load Transient

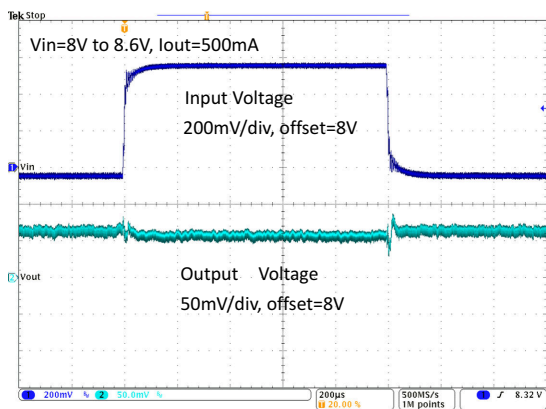

Figure 9-22. Line Transient

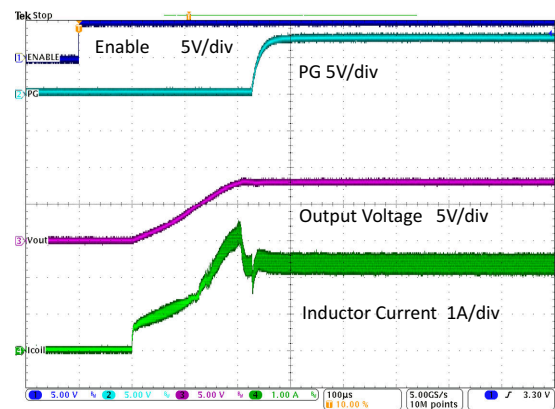

Figure 9-23. Startup After Enable

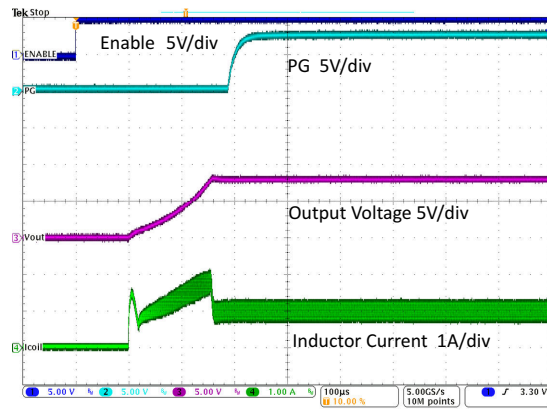

Figure 9-24. Startup After Enable

10 Power Supply Recommendations

The TPS6306x device family has no special requirements for its input power supply. The input supply output current must be rated according to the supply voltage, output voltage and output current of the TPS6306x.

11 Layout

11.1 Layout Guidelines

For all switching power supplies, the layout is an important step in the design, especially at high peak currents and high switching frequencies. If the layout is not carefully done, the regulator could show stability problems as well as EMI problems. Therefore, use wide and short traces for the main current path and for the power ground tracks. The input capacitor, output capacitor, and the inductor should be placed as close as possible to the device. Use a common ground node for power ground and a different one for control ground to minimize the effects of ground noise. Connect these ground nodes at any place close to one of the ground pins of the device.

The feedback divider should be placed as close as possible to the control ground pin of the device. To lay out the control ground, short traces are recommended as well, separation from the power ground traces. This avoids ground shift problems, which can occur due to superimposition of power ground current and control ground current.

11.2 Layout Example

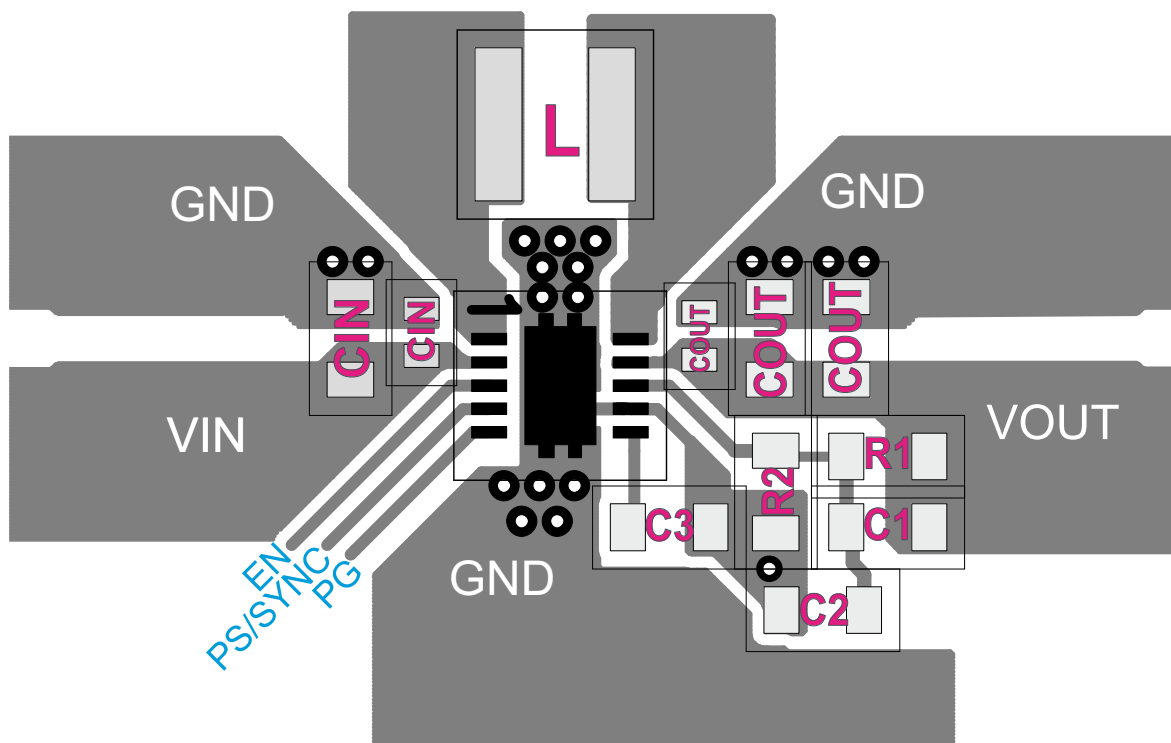

Figure 11-1. TPS6306x Layout

12 Device and Documentation Support

12.1 Device Support

12.1.1 Development Support

- TPS63060EVM-619 2.25-A, Buck-Boost Converter Evaluation Module (click [here](#))
- TPS63060EVM-619 Gerber Files ([SLVC409](#))
- TPS63060 PSpice Transient Model ([SLVM477](#))

12.2 Documentation Support

12.2.1 Related Documentation

For related documentation see the following:

- Design Calculations for Buck-Boost Converters ([SLVA535](#))
- Extending the Soft-Start Time in the TPS63010 Buck-Boost Converter ([SLVA553](#))
- Different Methods to Drive LEDs Using TPS63xxx Buck-Boost Converters ([SLVA419](#))

12.3 Receiving Notification of Documentation Updates

To receive notification of documentation updates, navigate to the device product folder on ti.com. In the upper right corner, click on *Alert me* to register and receive a weekly digest of any product information that has changed. For change details, review the revision history included in any revised document.

12.4 Community Resources

12.5 Trademarks

Buck-Boost Overlap Control™ is a trademark of Texas Instruments.
All other trademarks are the property of their respective owners.

13 Mechanical, Packaging, and Orderable Information

The following pages include mechanical, packaging, and orderable information. This information is the most current data available for the designated devices. This data is subject to change without notice and revision of this document. For browser-based versions of this data sheet, refer to the left-hand navigation.

PACKAGING INFORMATION

Orderable Device	Status (1)	Package Type	Package Drawing	Pins	Package Qty	Eco Plan (2)	Lead finish/ Ball material (6)	MSL Peak Temp (3)	Op Temp (°C)	Device Marking (4/5)	Samples
TPS63060DSCR	ACTIVE	WSON	DSC	10	3000	RoHS & Green	NIPDAU NIPDAUAG	Level-2-260C-1 YEAR	-40 to 125	QUJ	Samples
TPS63060DSCT	ACTIVE	WSON	DSC	10	250	RoHS & Green	NIPDAU NIPDAUAG	Level-2-260C-1 YEAR	-40 to 125	QUJ	Samples
TPS63061DSCR	ACTIVE	WSON	DSC	10	3000	RoHS & Green	NIPDAU NIPDAUAG	Level-2-260C-1 YEAR	-40 to 125	QUK	Samples
TPS63061DSCT	ACTIVE	WSON	DSC	10	250	RoHS & Green	NIPDAU NIPDAUAG	Level-2-260C-1 YEAR	-40 to 125	QUK	Samples

(1) The marketing status values are defined as follows:

ACTIVE: Product device recommended for new designs.

LIFEBUY: TI has announced that the device will be discontinued, and a lifetime-buy period is in effect.

NRND: Not recommended for new designs. Device is in production to support existing customers, but TI does not recommend using this part in a new design.

PREVIEW: Device has been announced but is not in production. Samples may or may not be available.

OBSELETE: TI has discontinued the production of the device.

(2) **RoHS:** TI defines "RoHS" to mean semiconductor products that are compliant with the current EU RoHS requirements for all 10 RoHS substances, including the requirement that RoHS substance do not exceed 0.1% by weight in homogeneous materials. Where designed to be soldered at high temperatures, "RoHS" products are suitable for use in specified lead-free processes. TI may reference these types of products as "Pb-Free".

RoHS Exempt: TI defines "RoHS Exempt" to mean products that contain lead but are compliant with EU RoHS pursuant to a specific EU RoHS exemption.

Green: TI defines "Green" to mean the content of Chlorine (Cl) and Bromine (Br) based flame retardants meet JS709B low halogen requirements of <=1000ppm threshold. Antimony trioxide based flame retardants must also meet the <=1000ppm threshold requirement.

(3) MSL, Peak Temp. - The Moisture Sensitivity Level rating according to the JEDEC industry standard classifications, and peak solder temperature.

(4) There may be additional marking, which relates to the logo, the lot trace code information, or the environmental category on the device.

(5) Multiple Device Markings will be inside parentheses. Only one Device Marking contained in parentheses and separated by a "-" will appear on a device. If a line is indented then it is a continuation of the previous line and the two combined represent the entire Device Marking for that device.

(6) Lead finish/Ball material - Orderable Devices may have multiple material finish options. Finish options are separated by a vertical ruled line. Lead finish/Ball material values may wrap to two lines if the finish value exceeds the maximum column width.

Important Information and Disclaimer:The information provided on this page represents TI's knowledge and belief as of the date that it is provided. TI bases its knowledge and belief on information provided by third parties, and makes no representation or warranty as to the accuracy of such information. Efforts are underway to better integrate information from third parties. TI has taken and

continues to take reasonable steps to provide representative and accurate information but may not have conducted destructive testing or chemical analysis on incoming materials and chemicals. TI and TI suppliers consider certain information to be proprietary, and thus CAS numbers and other limited information may not be available for release.

In no event shall TI's liability arising out of such information exceed the total purchase price of the TI part(s) at issue in this document sold by TI to Customer on an annual basis.

OTHER QUALIFIED VERSIONS OF TPS63060 :

- Enhanced Product : [TPS63060-EP](#)

NOTE: Qualified Version Definitions:

- Enhanced Product - Supports Defense, Aerospace and Medical Applications

TAPE AND REEL INFORMATION

QUADRANT ASSIGNMENTS FOR PIN 1 ORIENTATION IN TAPE

*All dimensions are nominal

Device	Package Type	Package Drawing	Pins	SPQ	Reel Diameter (mm)	Reel Width W1 (mm)	A0 (mm)	B0 (mm)	K0 (mm)	P1 (mm)	W (mm)	Pin1 Quadrant
TPS63060DSCR	WSON	DSC	10	3000	330.0	12.4	3.3	3.3	1.1	8.0	12.0	Q2
TPS63060DSCT	WSON	DSC	10	250	180.0	12.5	3.3	3.3	1.1	8.0	12.0	Q2
TPS63061DSCR	WSON	DSC	10	3000	330.0	12.4	3.3	3.3	1.1	8.0	12.0	Q2
TPS63061DSCT	WSON	DSC	10	250	180.0	12.5	3.3	3.3	1.1	8.0	12.0	Q2

TAPE AND REEL BOX DIMENSIONS

*All dimensions are nominal

Device	Package Type	Package Drawing	Pins	SPQ	Length (mm)	Width (mm)	Height (mm)
TPS63060DSCR	WSON	DSC	10	3000	356.0	356.0	35.0
TPS63060DSCT	WSON	DSC	10	250	205.0	200.0	33.0
TPS63061DSCR	WSON	DSC	10	3000	356.0	356.0	35.0
TPS63061DSCT	WSON	DSC	10	250	205.0	200.0	33.0

GENERIC PACKAGE VIEW

DSC 10

WSON - 0.8 mm max height

PLASTIC SMALL OUTLINE - NO LEAD

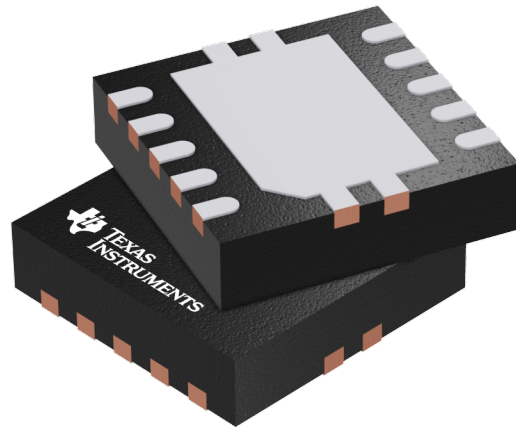

Images above are just a representation of the package family, actual package may vary.
Refer to the product data sheet for package details.

4207383/F

DSC (S-PWSON-N10)

PLASTIC SMALL OUTLINE NO-LEAD

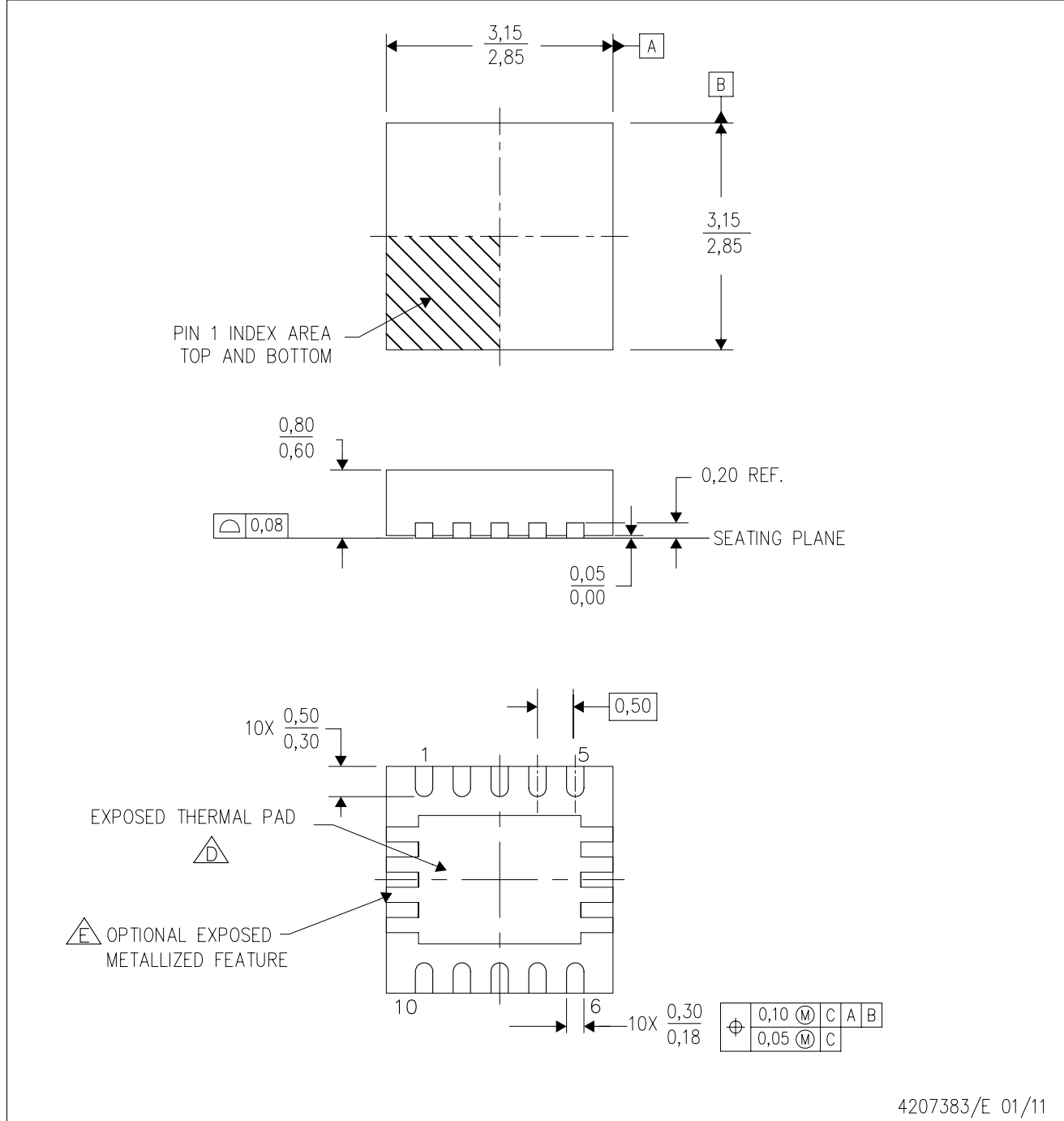

- NOTES:
- A. All linear dimensions are in millimeters. Dimensioning and tolerancing per ASME Y14.5M-1994.
 - B. This drawing is subject to change without notice.
 - C. Small Outline No-Lead (SON) package configuration.
 - The package thermal pad must be soldered to the board for thermal and mechanical performance.
 - See the Product Data Sheet for details regarding the exposed thermal pad features and dimensions.

THERMAL PAD MECHANICAL DATA

DSC (S-PWSON-N10)

PLASTIC SMALL OUTLINE NO-LEAD

THERMAL INFORMATION

This package incorporates an exposed thermal pad that is designed to be attached directly to an external heatsink. The thermal pad must be soldered directly to the printed circuit board (PCB). After soldering, the PCB can be used as a heatsink. In addition, through the use of thermal vias, the thermal pad can be attached directly to the appropriate copper plane shown in the electrical schematic for the device, or alternatively, can be attached to a special heatsink structure designed into the PCB. This design optimizes the heat transfer from the integrated circuit (IC).

For information on the Quad Flatpack No-Lead (QFN) package and its advantages, refer to Application Report, QFN/SON PCB Attachment, Texas Instruments Literature No. SLUA271. This document is available at www.ti.com.

The exposed thermal pad dimensions for this package are shown in the following illustration.

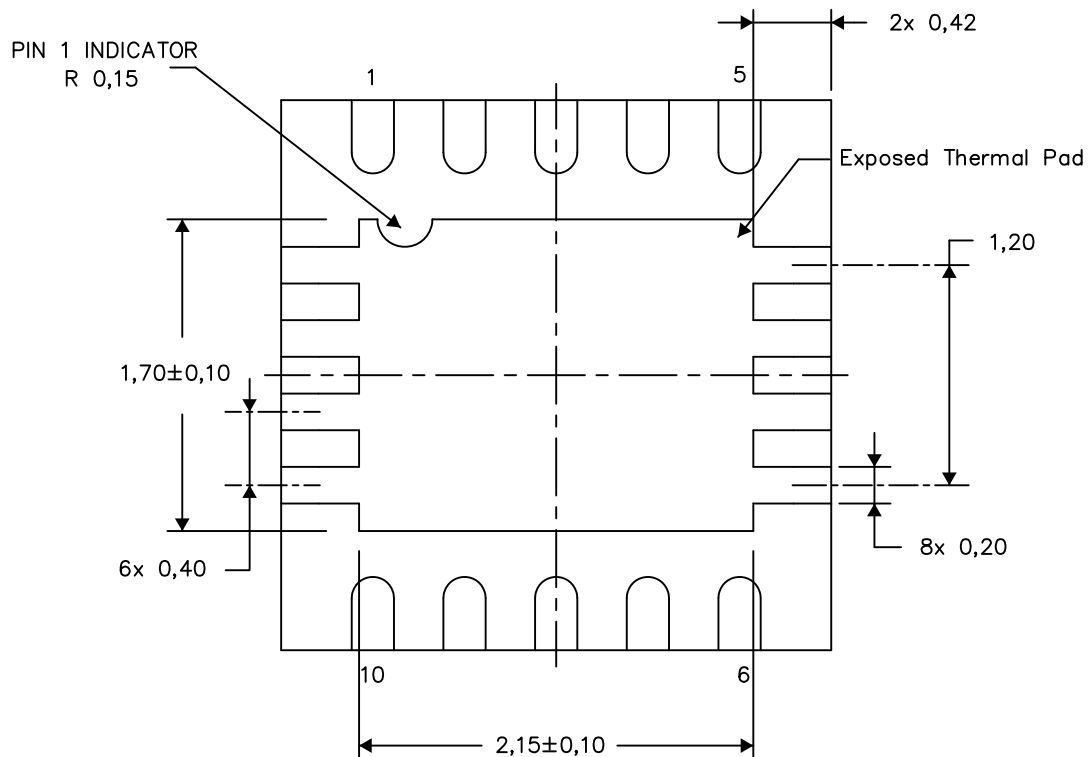

Bottom View

Exposed Thermal Pad Dimensions

4210391-5/Q 08/15

NOTE: A. All linear dimensions are in millimeters

DSC (S-PWSON-N10)

PLASTIC SMALL OUTLINE NO-LEAD

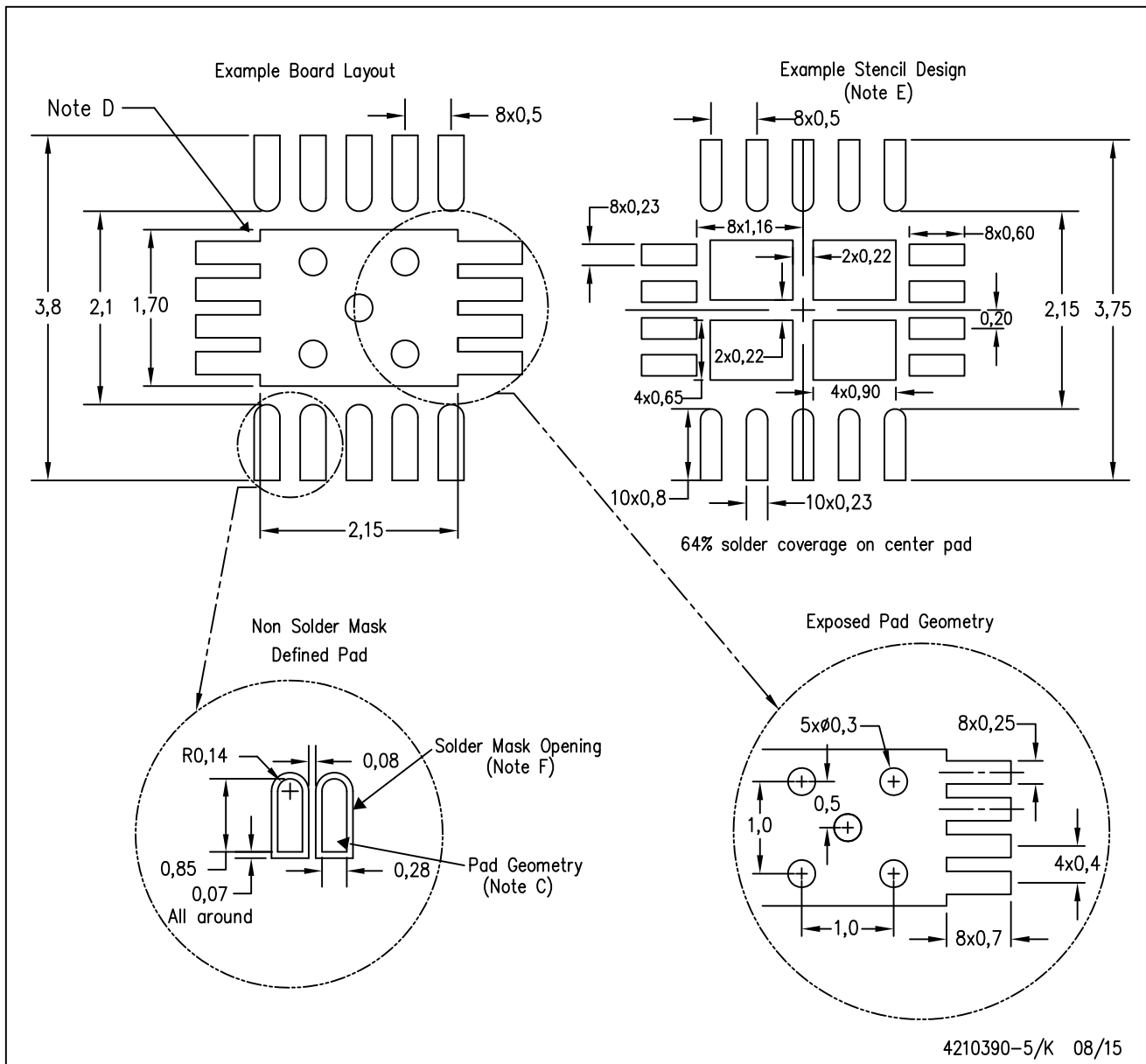

- NOTES:
- All linear dimensions are in millimeters.
 - This drawing is subject to change without notice.
 - Publication IPC-7351 is recommended for alternate designs.
 - This package is designed to be soldered to a thermal pad on the board. Refer to Application Note, Quad Flat-Pack Packages, Texas Instruments Literature No. SLUA271, and also the Product Data Sheets for specific thermal information, via requirements, and recommended board layout. These documents are available at www.ti.com <<http://www.ti.com>>.
 - Laser cutting apertures with trapezoidal walls and also rounding corners will offer better paste release. Customers should contact their board assembly site for stencil design recommendations. Refer to IPC 7525 for stencil design considerations.
 - Customers should contact their board fabrication site for minimum solder mask web tolerances between signal pads.

IMPORTANT NOTICE AND DISCLAIMER

TI PROVIDES TECHNICAL AND RELIABILITY DATA (INCLUDING DATA SHEETS), DESIGN RESOURCES (INCLUDING REFERENCE DESIGNS), APPLICATION OR OTHER DESIGN ADVICE, WEB TOOLS, SAFETY INFORMATION, AND OTHER RESOURCES "AS IS" AND WITH ALL FAULTS, AND DISCLAIMS ALL WARRANTIES, EXPRESS AND IMPLIED, INCLUDING WITHOUT LIMITATION ANY IMPLIED WARRANTIES OF MERCHANTABILITY, FITNESS FOR A PARTICULAR PURPOSE OR NON-INFRINGEMENT OF THIRD PARTY INTELLECTUAL PROPERTY RIGHTS.

These resources are intended for skilled developers designing with TI products. You are solely responsible for (1) selecting the appropriate TI products for your application, (2) designing, validating and testing your application, and (3) ensuring your application meets applicable standards, and any other safety, security, regulatory or other requirements.

These resources are subject to change without notice. TI grants you permission to use these resources only for development of an application that uses the TI products described in the resource. Other reproduction and display of these resources is prohibited. No license is granted to any other TI intellectual property right or to any third party intellectual property right. TI disclaims responsibility for, and you will fully indemnify TI and its representatives against, any claims, damages, costs, losses, and liabilities arising out of your use of these resources.

TI's products are provided subject to [TI's Terms of Sale](#) or other applicable terms available either on [ti.com](https://www.ti.com) or provided in conjunction with such TI products. TI's provision of these resources does not expand or otherwise alter TI's applicable warranties or warranty disclaimers for TI products.

TI objects to and rejects any additional or different terms you may have proposed.

Mailing Address: Texas Instruments, Post Office Box 655303, Dallas, Texas 75265
Copyright © 2024, Texas Instruments Incorporated

Looking for pricing, stock, or lifecycle information?

Click below to explore more details on WIN SOURCE:

 [View TPS63061DSCR](#) on WIN SOURCE

 [Texas Instruments](#) Information

Optimize Your Supply Chain with WIN SOURCE Solutions

-  Global Sourcing Solution
-  Obsolete Management
-  Cost Control Management
-  Shortage Management
-  Alternative Solution
-  Excess Inventory Management