



**THE DATASHEET OF
TPS64203DBVT**





SOT23 STEP-DOWN CONTROLLER

FEATURES

- Step-Down Controller for Applications With up to 95% Efficiency
- 1.8-V to 6.5-V Operating Input Voltage Range
- Adjustable Output Voltage Range From 1.2 V to V_I
- High Efficiency Over a Wide Load Current Range
- 100% Maximum Duty Cycle for Lowest Dropout
- Internal Softstart
- 20- μ A Quiescent Current (Typical)
- Overcurrent Protected
- Available in a SOT23 Package

APPLICATIONS

- USB Powered Peripherals
- Organizers, PDAs, and Handheld PCs

- Low Power DSP Supply
- Digital Cameras
- Hard Disk Drives
- Portable Audio Players

DESCRIPTION

The TPS6420x are nonsynchronous step-down controllers that are ideally suited for systems powered from a 5-V or 3.3-V bus or for applications powered from a 1-cell Li-Ion battery or from a 2- to 4-cell NiCd, NiMH, or alkaline battery. These step-down controllers drive an external P-channel MOSFET allowing design flexibility. To achieve highest efficiency over a wide load current range, this controller uses a minimum on time, minimum off time control scheme and consumes only 20- μ A quiescent current. The minimum on time of typically 600 ns (TPS64203) allows the use of small inductors and capacitors. When disabled, the current consumption is reduced to less than 1 μ A. The TPS6420x is available in the 6-pin SOT23 (DBV) package and operates over a free air temperature range of -40°C to 85°C .

TYPICAL APPLICATION CIRCUIT

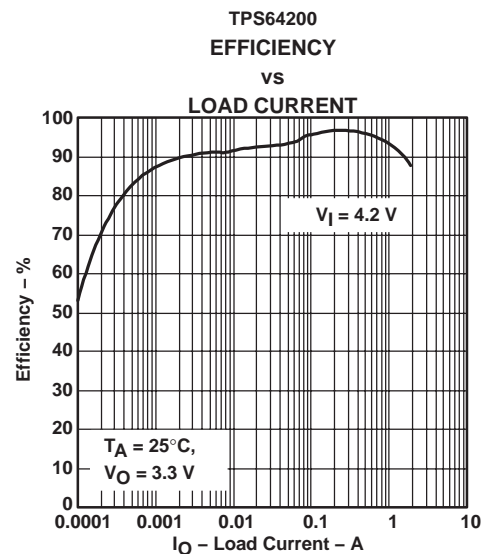
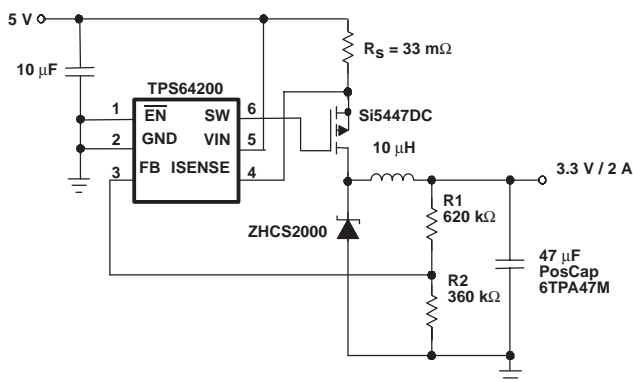

Please be aware that an important notice concerning availability, standard warranty, and use in critical applications of Texas Instruments semiconductor products and disclaimers thereto appears at the end of this data sheet.



These devices have limited built-in ESD protection. The leads should be shorted together or the device placed in conductive foam during storage or handling to prevent electrostatic damage to the MOS gates.

ORDERING INFORMATION

| PLASTIC SOT23-6 ⁽¹⁾ (2) (DBV) | OUTPUT VOLTAGE | MINIMUM ON-TIME | MINIMUM OFF-TIME | MARKING |
|---|------------------------------|--------------------------|-------------------|---------|
| TPS64200DBVR | Adjustable 1.2 V to V_I | ON time = 1.6 μ s | OFF time = 600 ns | PJAI |
| TPS64201DBVR | Adjustable 1.2 V to V_I | Variable minimum on time | OFF time = 600 ns | PJBI |
| TPS64202DBVR | Adjustable 1.2 V to V_I | Variable minimum on time | OFF time = 300 ns | PJCI |
| TPS64203DBVR | Adjustable 1.2 V to V_I | ON time = 600 ns | OFF time = 600 ns | PJDI |

(1) The R suffix indicates shipment in tape and reel with 3000 units per reel.

(2) The T suffix indicates a mini reel with 250 units per reel.

ABSOLUTE MAXIMUM RATINGS

over operating free-air temperature range unless otherwise noted⁽¹⁾

| | |
|--|--------------------|
| Supply voltage, V_{IN} | -0.3 V to 7 V |
| Voltage at \overline{EN} , SW, ISENSE | -0.3 V to V_{IN} |
| Voltage at FB | -0.3 V to 3.3 V |
| Maximum junction temperature, T_J | 150°C |
| Operating free-air temperature, T_A | -40°C to 85°C |
| Storage temperature, T_{Sgt} | -65°C to 150°C |
| Lead temperature 1,6 mm (1/16 inch) from case for 10 seconds | 300°C |

(1) Stresses beyond those listed under "absolute maximum ratings" may cause permanent damage to the device. These are stress ratings only, and functional operation of the device at these or any other conditions beyond those indicated under "recommended operating conditions" is not implied. Exposure to absolute-maximum-rated conditions for extended periods may affect device reliability.

PACKAGE DISSIPATION RATINGS

| PACKAGE | $T_A \leq 25^\circ\text{C}$ POWER RATING | DERATING FACTOR ABOVE $T_A = 25^\circ\text{C}$ | $T_A = 70^\circ\text{C}$ POWER RATING | $T_A = 85^\circ\text{C}$ POWER RATING |
|---------|---|---|--|--|
| SOT23-6 | 400 mW | 4 mW/°C | 220 mW | 180 mW |

NOTE: The thermal resistance junction to ambient of the 6-pin SOT23 package is 250°C/W.

RECOMMENDED OPERATING CONDITIONS

| | MIN | NOM | MAX | UNIT |
|--------------------------------|-----|-----|-----|------|
| Supply voltage at V_{IN} | 1.8 | | 6.5 | V |
| Operating junction temperature | -40 | | 125 | °C |

ELECTRICAL CHARACTERISTICS

$V_{IN} = 3.8\text{ V}$, $V_O = 3.3\text{ V}$, $EN = V_{IN}$, $T_A = -40^\circ\text{C}$ to 85°C (unless otherwise noted)

| SUPPLY CURRENT | | | | | | |
|----------------------|--|---|----------|-------|-------|---------------|
| PARAMETER | | TEST CONDITIONS | MIN | TYP | MAX | UNIT |
| V_I | Input voltage range | | 1.8 | | 6.5 | V |
| $I_{(Q)}$ | Operating quiescent current | $I_O = 0\text{ mA}$ | | 20 | 35 | μA |
| $I_{(SD)}$ | Shutdown current | $\overline{EN} = V_I$ | | 0.1 | 1 | μA |
| OUTPUT/CURRENT LIMIT | | | | | | |
| V_O | Adjustable output voltage range | | V_{FB} | | V_I | V |
| V_{FB} | Feedback voltage | | | 1.213 | | V |
| | Feedback leakage current | | | 0.01 | 0.2 | μA |
| | Feedback voltage tolerance | | -2 | | +2 | % |
| $V_{(ISENSE)}$ | Reference voltage for current limit | | 90 | 105 | 120 | mV |
| | ISENSE leakage current | | | 0.01 | 0.2 | μA |
| | Line regulation | Measured with circuit according to Figure 1 | | 0.6 | | %/V |
| | Load regulation | Measured with circuit according to Figure 1 $V_I = 3.8\text{ V}$ | | 0.6 | | %/A |
| η | Efficiency | Measured with circuit according to Figure 1 $V_I = 3.8\text{ V}$, $V_O = 3.3\text{ V}$, $I_O = 1000\text{ mA}$ | | 94% | | |
| | | Measured with circuit according to Figure 1 $V_I = 3.8\text{ V}$, $V_O = 1.2\text{ V}$, $I_O = 800\text{ mA}$ | | 80% | | |
| | Start-up time | $I_O = 0\text{ mA}$, Time from active EN to V_O , $C_O = 47\text{ }\mu\text{F}$ | | 0.25 | | ms |
| GATE DRIVER (SW-PIN) | | | | | | |
| $r_{DS(ON)}$ | P-channel MOSFET on-resistance | $V_I \geq 2.5\text{ V}$ | | 4 | | Ω |
| | | $V_I = 1.8\text{ V}$ | | 6 | | |
| $r_{DS(ON)}$ | N-channel MOSFET on-resistance | $V_I \geq 2.5\text{ V}$ | | 4 | | Ω |
| | | $V_I = 1.8\text{ V}$ | | 6 | | |
| I_O | Maximum gate drive output current, SW | | | | 150 | mA |
| ENABLE | | | | | | |
| V_{IH} | \overline{EN} high level input voltage | Device is off | 1.3 | | | V |
| V_{IL} | \overline{EN} low level input voltage | Device is operating | | | 0.3 | V |
| | \overline{EN} trip point hysteresis | | | 115 | | mV |
| I_{lkg} | \overline{EN} input leakage current | $\overline{EN} = \text{GND or } V_{IN}$ | | 0.01 | 0.2 | μA |
| $V_{(UVLO)}$ | Undervoltage lockout threshold | | | 1.7 | | V |
| ON TIME and OFF TIME | | | | | | |
| t_{on} | Minimum on time | TPS64200, TPS64201, TPS64202 | 1.36 | 1.6 | 1.84 | μs |
| | | TPS64203 only | 0.56 | 0.65 | 0.74 | |
| | Reduced on time 1 | TPS64201, TPS64202 | | 0.80 | | μs |
| | Reduced on time 2 | TPS64201, TPS64202 | | 0.40 | | μs |
| | Reduced on time 3 | TPS64201, TPS64202 | | 0.20 | | μs |
| t_{off} | Minimum off time | TPS64200, TPS64201, TPS64203 | 0.44 | 0.55 | 0.66 | μs |
| | | TPS64202 only | 0.24 | 0.3 | 0.36 | |

PIN ASSIGNMENTS

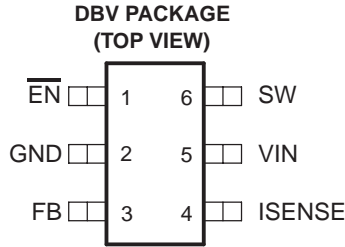

Terminal Functions

| TERMINAL NAME | NO. | I/O | DESCRIPTION |
|------------------------|-----|-----|---|
| $\overline{\text{EN}}$ | 1 | I | Enable. A logic low enables the converter, logic high forces the device into shutdown mode reducing the supply current to less than 1 μA . |
| FB | 3 | I | Feedback pin. Connect an external voltage divider to this pin to set the output voltage. |
| GND | 2 | I | Ground |
| SW | 6 | O | This pin connects to the gate of an external P-channel MOSFET. |
| ISENSE | 4 | I | Current sense input. Connect the current sense resistor between VIN and ISENSE. (optional) |
| VIN | 5 | I | Supply voltage input |

FUNCTIONAL BLOCK DIAGRAM

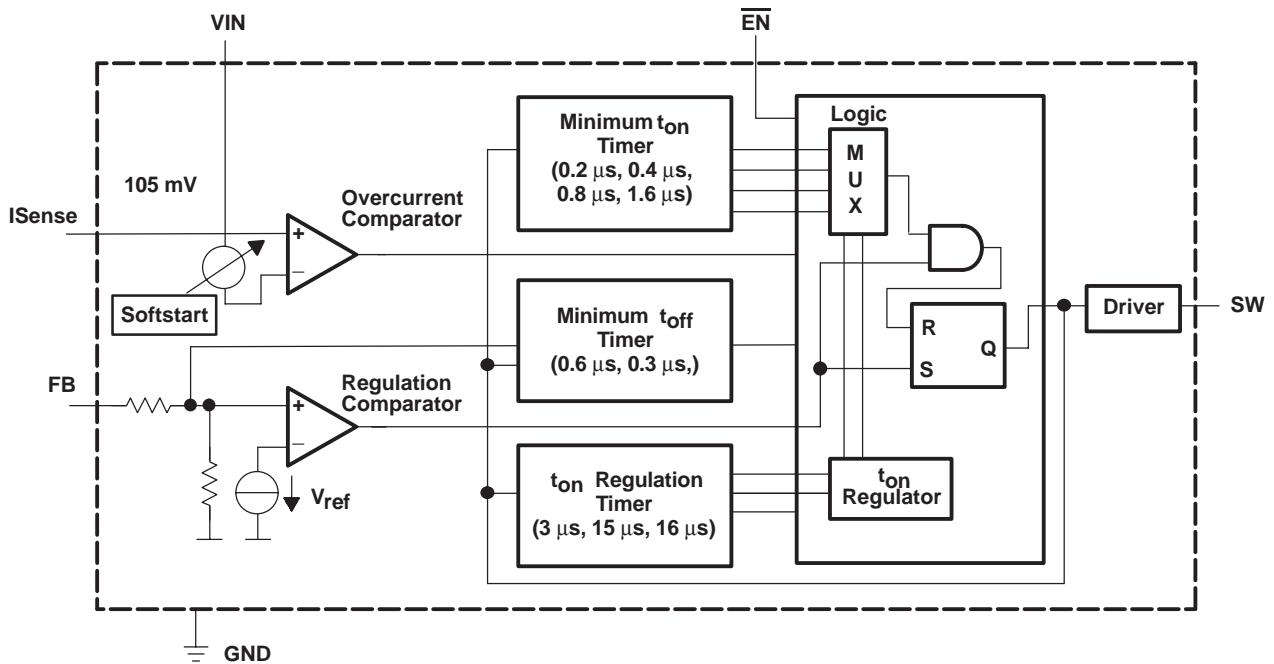

TYPICAL CHARACTERISTICS

All graphs were generated using the circuit as shown unless otherwise noted. For output voltages other than 3.3 V, the output voltage divider was changed accordingly. Graphs for the TPS64203 were taken using the application circuit shown in Figure 25.

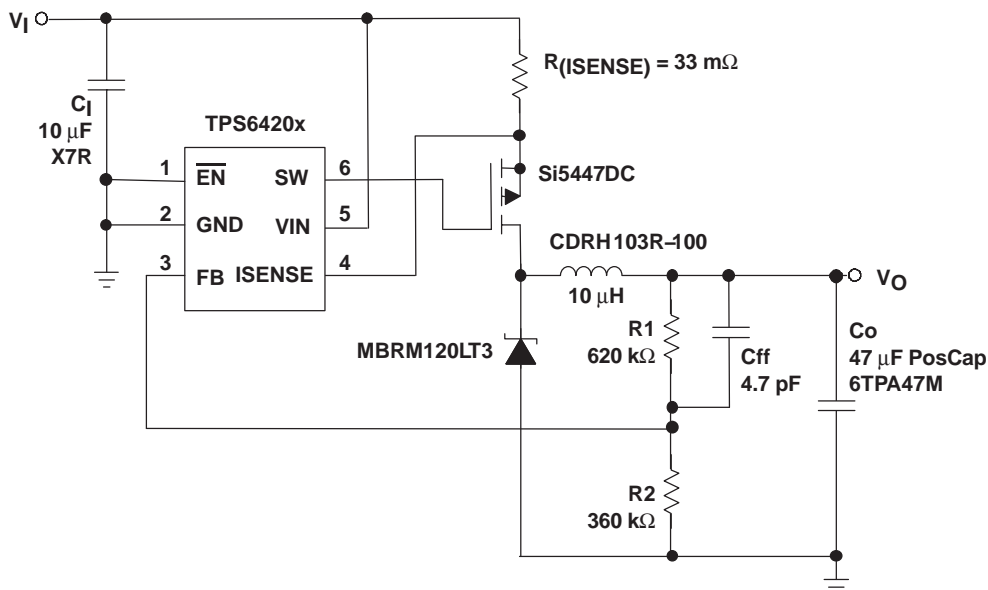
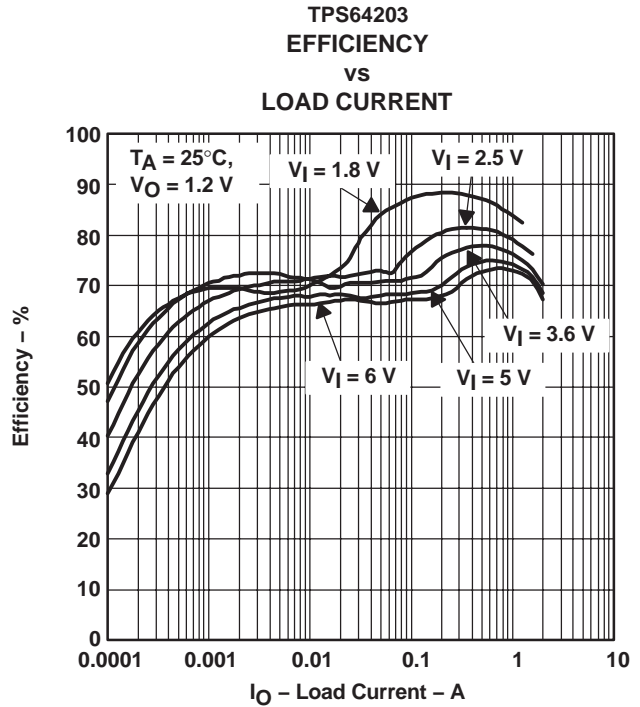
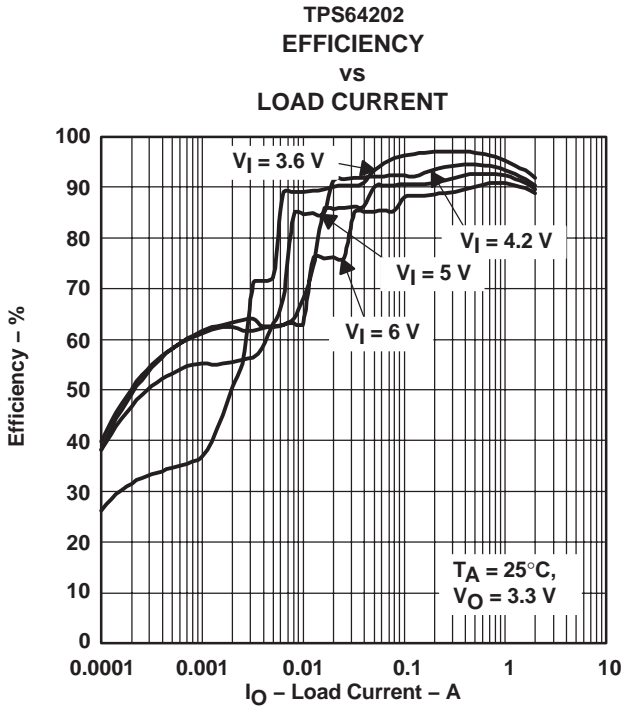
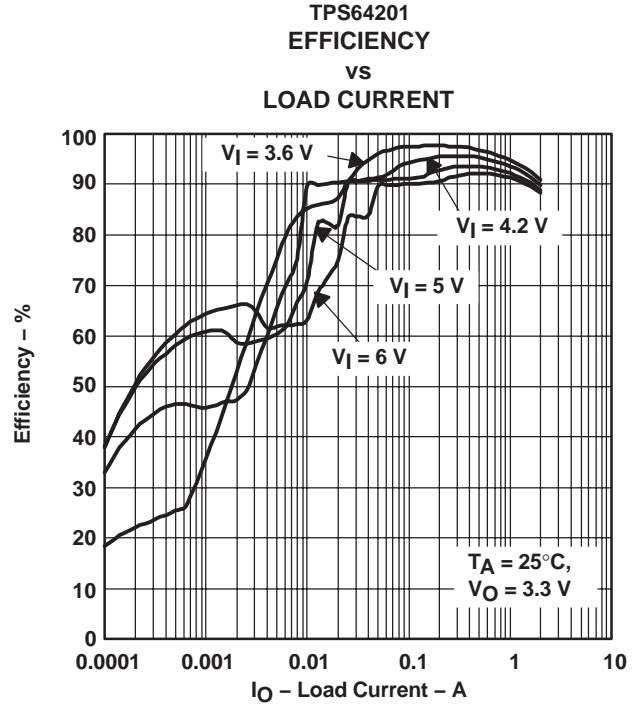
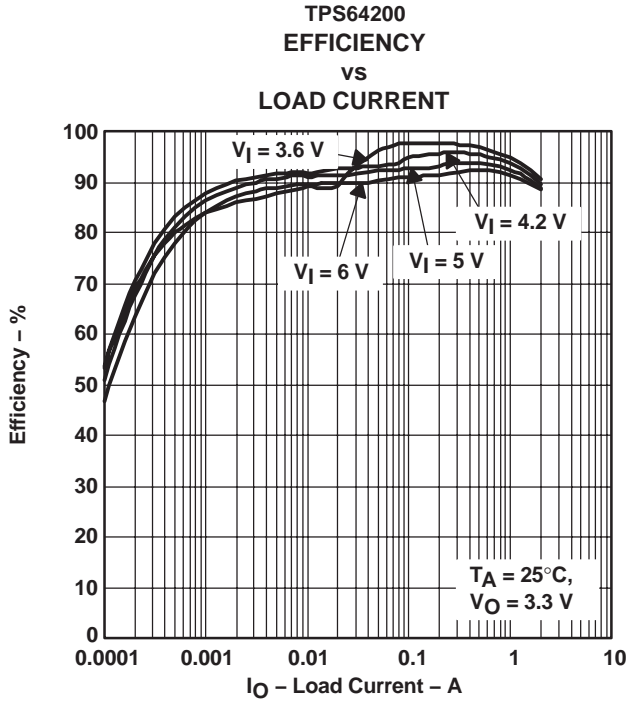
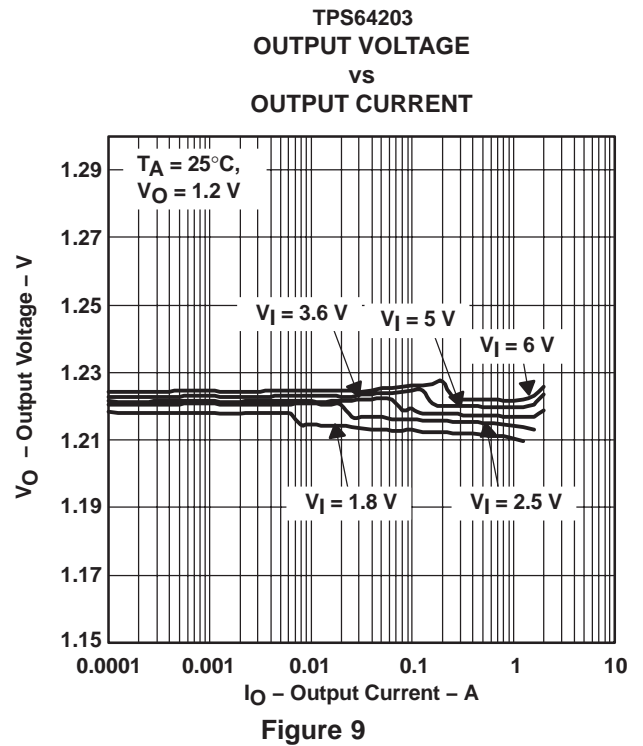
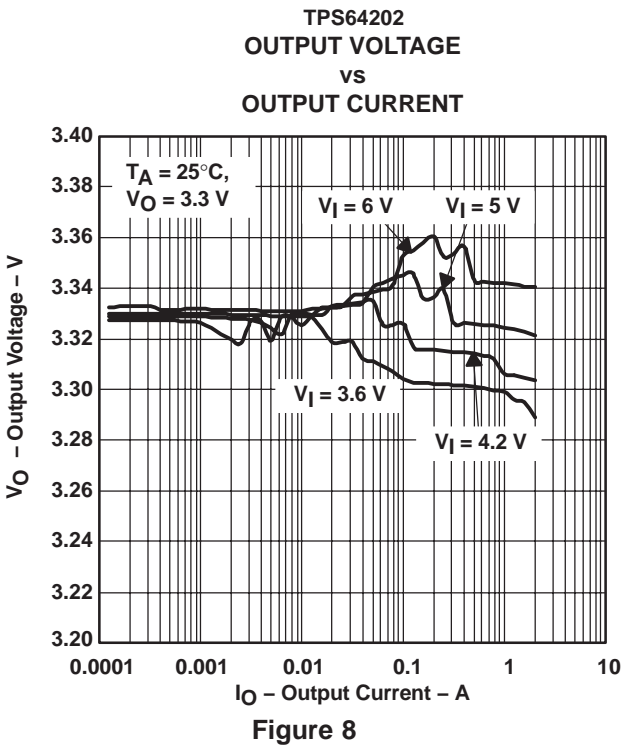
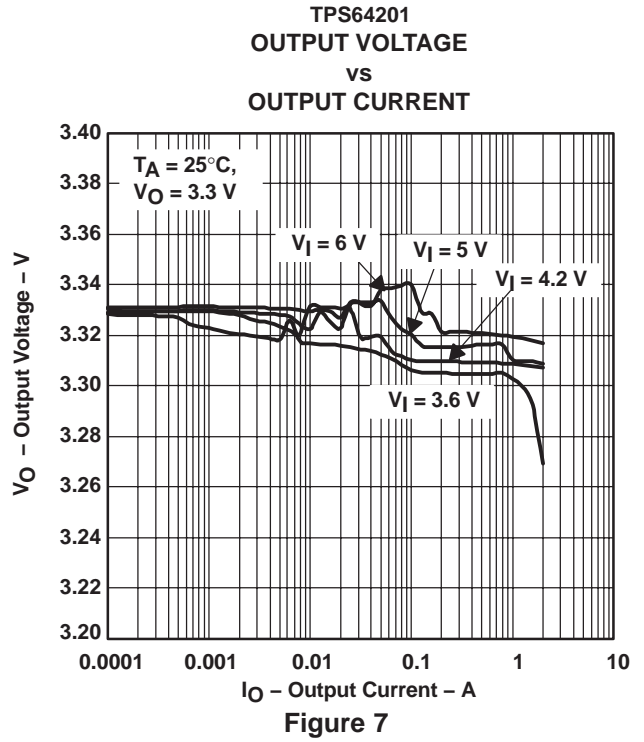
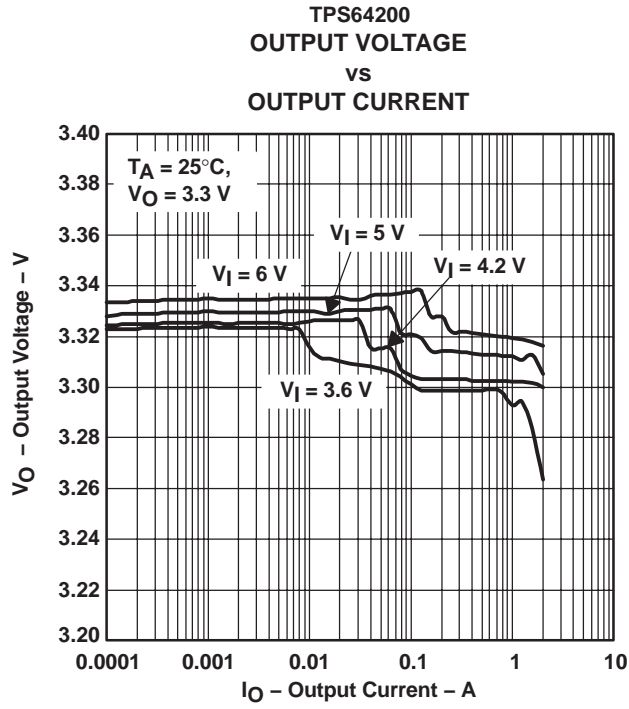

Figure 1. Basic Application Circuit For a 2-A Step-Down Converter

TABLE OF GRAPHS

| | | | FIGURE |
|--------|-----------------------------|-------------------------------------|---------|
| η | Efficiency | vs Load current | 2 – 5 |
| | Output voltage | vs Output current | 6 – 9 |
| | Switching frequency | vs Output current | 10 – 13 |
| | Operating quiescent current | vs Input voltage | 14 |
| | Output voltage ripple | | 15 |
| | Line transient response | Using circuit according to Figure 1 | 16 |
| | Load transient response | Using circuit according to Figure 1 | 17 |
| | Start-up timing | Using circuit according to Figure 1 | 18 |





TPS64200
 SWITCHING FREQUENCY
 vs
 OUTPUT CURRENT

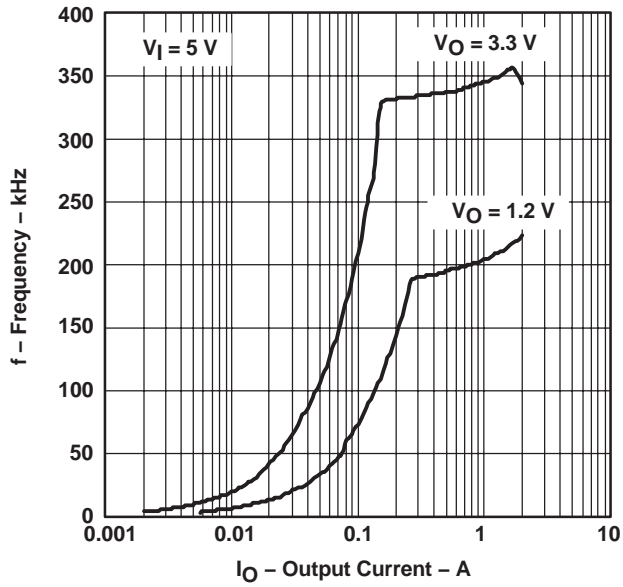

Figure 10

TPS64201
 SWITCHING FREQUENCY
 vs
 OUTPUT CURRENT

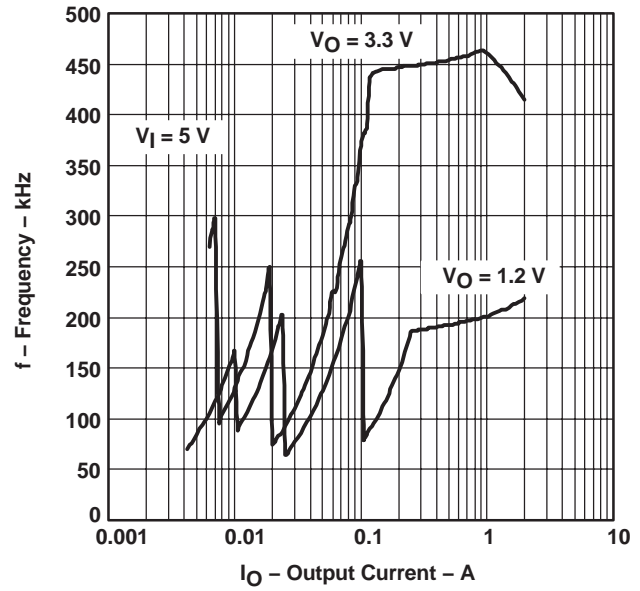

Figure 11

TPS64202
 SWITCHING FREQUENCY
 vs
 OUTPUT CURRENT

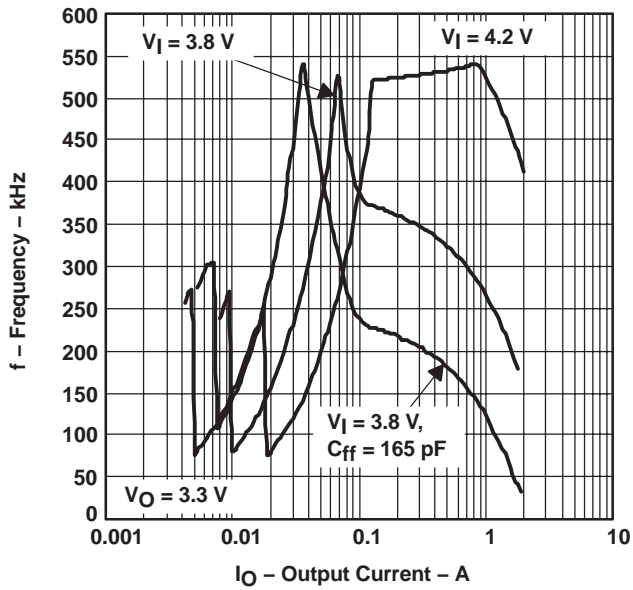

Figure 12

TPS64203
 SWITCHING FREQUENCY
 vs
 OUTPUT CURRENT

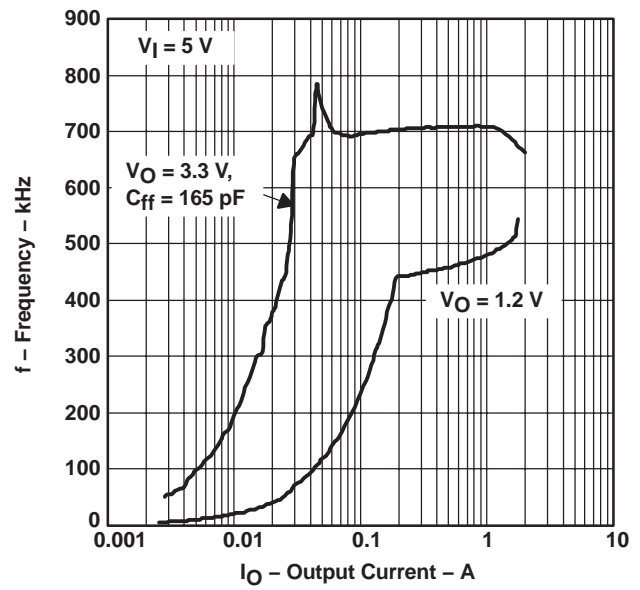

Figure 13

TPS642000
OPERATING QUIESCENT CURRENT
VS
INPUT VOLTAGE

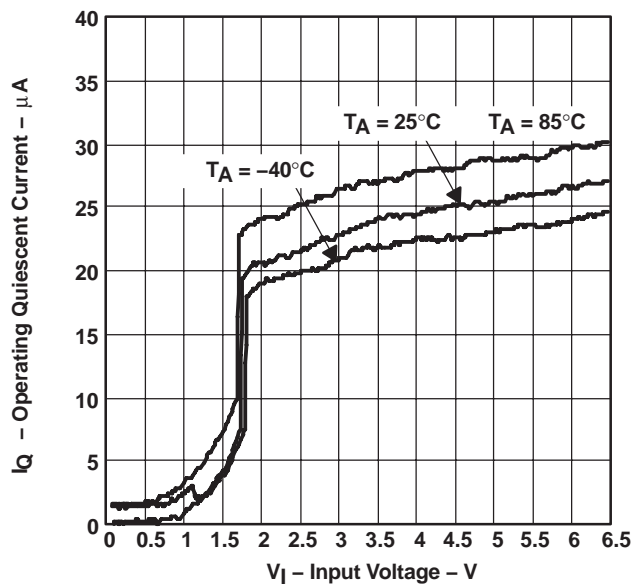

Figure 14

TPS64200
OUTPUT VOLTAGE RIPPLE

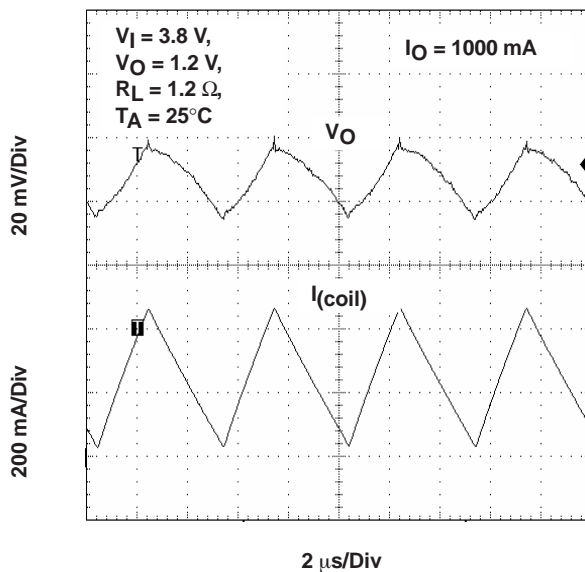

Figure 15

TPS64200
LINE TRANSIENT RESPONSE

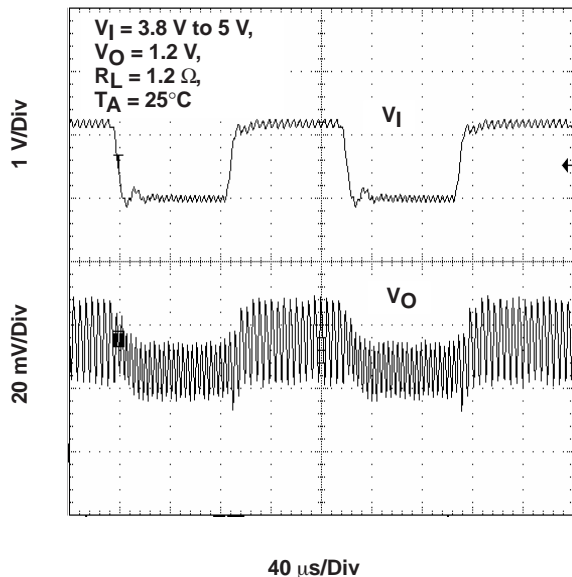

Figure 16

TPS64203
LOAD TRANSIENT RESPONSE

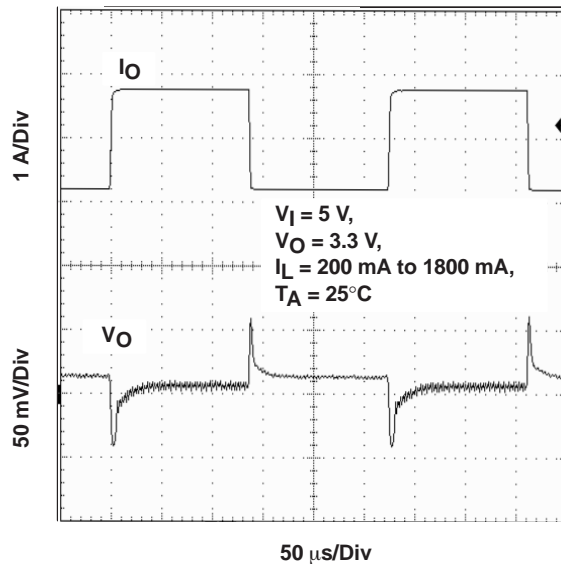

Figure 17

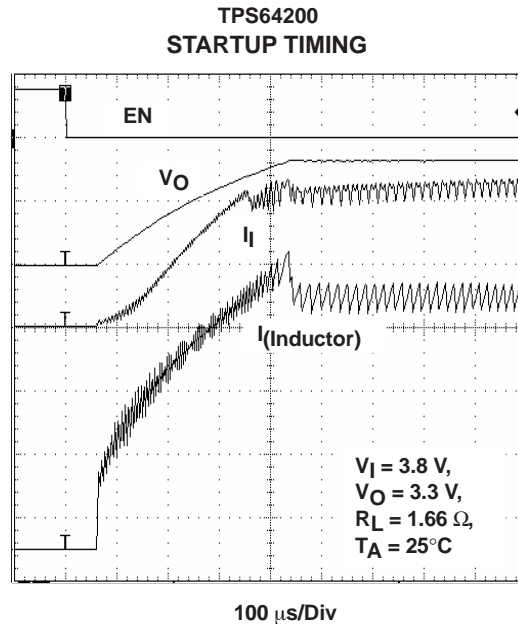

Figure 18

DETAILED DESCRIPTION

Operation

The TPS6420x is a nonsynchronous step-down controller which is operating with a minimum on-time/minimum off-time control. An external PMOS is turned on until the output voltage reaches its nominal value or the current limit is exceeded. If the current limit is exceeded, the PMOS is switched off and stays off for the minimum off-time. After that the PMOS is switched on again. When the nominal output voltage is reached, the PMOS is switched off and stays off until the output voltage dropped below its nominal value.

Operating Modes

When delivering low or medium output current, the TPS6420x operate in discontinuous mode. With every switching cycle, the current in the inductor starts at zero, rises to a maximum value and ramps down to zero again. As soon as the current in the inductor drops to zero, ringing occurs at the resonant frequency of the inductor and stray capacitance, due to residual energy in the inductor when the diode turns off. Ringing in discontinuous mode is normal and does not have any influence on efficiency. The ringing does not contain much energy and can easily be damped by an RC snubber. See the application section for further details.

With high output current, the TPS6420x operate in continuous current mode. In this mode, the inductor current does not drop to zero within one switching cycle. The output voltage in continuous mode is directly dependant on the duty cycle of the switch.

Variable Minimum On-Time (TPS64201 to TPS64202 Only)

The minimum on-time of the device is 1.6 μ s. At light loads, this would cause a low switching frequency in the audible range because the energy transferred to the output during the on-time would cause a higher rise in the output voltage than needed and therefore lead to a long off-time until the output voltage dropped again. To avoid a switching frequency in the audible range the TPS64201 and TPS64202 can internally reduce the minimum on time in three steps from 1.6 μ s to 800 ns, 400 ns and 200 ns. The on-time is reduced by one step if the switching frequency dropped to a lower value than 50 kHz. This keeps the frequency above the audio frequency over a wide load range and also keeps the output voltage ripple low.

Soft Start

The TPS6420x has an internal soft start circuit that limits the inrush current during start up. This prevents possible voltage drops of the input voltage in case a battery or a high impedance power source is connected to the input of the TPS6420x. During soft start the current limit is increased from 25% of its maximum to the maximum within about 250 μ s.

100% Duty Cycle Low Dropout Operation

The TPS6420x offers the lowest possible input to output voltage difference while still maintaining regulation with the use of the 100% duty cycle mode. In this mode the P-channel switch is constantly turned on. This is particularly useful in battery powered applications to achieve longest operation time by taking full advantage of the whole battery voltage range.

Enable

A voltage higher than the EN trip point of 1.3 V up to the input voltage forces the TPS64200 into shutdown. In shutdown, the power switch, drivers, voltage reference, oscillator, and all other functions are turned off. The supply current is reduced to less than 1 μ A in shutdown. Pulling enable low starts up the TPS64200 with the softstart as described under the chapter softstart.

Undervoltage Lockout

The undervoltage lockout circuit prevents the device from misoperation at low input voltages. Basically, it prevents the converter from turning on the external PMOS under undefined conditions.

Current Limit

The ISENSE input is used to set the current limit for the external PMOS. The sense resistor must be connected between V_I and source of the external PMOS. The ISENSE pin is connected to the source of the external PMOS. The maximum current is calculated by:

$$I_{(\text{cur lim})} = \frac{V_{(\text{ISENSE})}}{R_S} \quad (1)$$

For low cost solutions the $r_{DS(\text{on})}$ of the external PMOS can also be used to set the current limit. In this case the ISENSE pin is connected to the drain of the PMOS. The current in the PMOS is automatically sampled by the TPS6420x some 10 ns after the PMOS is turned on. The ISENSE pin should always be connected to either the source of the PMOS or the drain if an additional sense resistor is used. Otherwise there is no working overcurrent protection and no soft start in the system. The maximum drain current if the $r_{DS(\text{on})}$ is used as a sense resistor is calculated by:

$$I_{(\text{cur lim})} = \frac{V_{(\text{ISENSE})}}{r_{DS(\text{on})}} \quad (2)$$

Short-Circuit Protection

With a controller only limited short circuit protection is possible because the temperature of the external components is not supervised. In an overload condition, the current in the external diode may exceed the maximum rating. To protect the diode against overcurrent, the off-time of the TPS6420x is increased when the voltage at the feedback pin is lower than its nominal value. The off-time when the output is shorted (feedback voltage is zero) is about 4 μ s. This allows the current in the external diode to drop until the PMOS is turned on again and the overcurrent protection switches off the PMOS again. The off-time is directly proportional to the voltage at feedback.

THEORY OF OPERATION

The basic application circuit for the TPS64200 is shown in Figure 1. External component selection is driven by the load requirement. It begins with the selection of the current sense resistor $R_{(ISENSE)}$ followed by the output diode, the inductor L , and the output and input capacitors. The inductor is chosen based on the desired amount of ripple current and switching frequency. The output capacitor is chosen large enough to meet the required output ripple and transient requirements. The ESR of the output capacitor is needed for stability of the converter. Therefore, an output capacitor with a certain amount of ESR is needed for the standard application circuit. See the application information for more details. The input capacitor must be capable of handling the required RMS input current.

Setting the Inductor Current Limit

The ISENSE pin is connected to an internal current comparator with a threshold of $120 \text{ mV}/R_{(ISENSE)}$. The current comparator sets the peak inductor current. As the current limit is intended to protect the external PMOS the limit must not be reached in normal operation. Set the current limit to about 1.3 times the maximum output current or higher if desired. This takes into account a certain amount of inductor current ripple. The current limit may also influence the start-up time when the current limit is exceeded during start up.

$$R_{(ISENSE)} \leq \frac{V_{(ISENSE) \text{ min}}}{1.3 \times I_O} \quad I_O \text{ — maximum output current in continuous conduction mode} \quad V_{(ISENSE) \text{ min}} = 90 \text{ mV} \quad (3)$$

The current sense resistor's power rating should be:

$$P_{(ISENSE)} \geq \frac{\left(V_{(ISENSE) \text{ max}}\right)^2}{R_{(ISENSE)}} \quad V_{(ISENSE) \text{ max}} = 120 \text{ mV} \quad (4)$$

Setting the Output Voltage

The output voltage of the TPS64200 to TPS64202 can be set using an external resistor divider. The sum of R_1 and R_2 should not exceed $1 \text{ M}\Omega$ to keep the influence of leakage current into the feedback pin low.

$$V_O = V_{FB} \times \frac{R_1 + R_2}{R_2} \quad R_1 = R_2 \times \left(\frac{V_O}{V_{FB}}\right) - R_2 \quad \text{with } V_{FB} = 1.2 \text{ V} \quad (5)$$

In some applications, depending on the layout, the capacitance may be too high from FB to GND. In this case, the internal comparator may not switch fast enough to operate with the minimum on-time or the minimum off-time given in this data sheet. For such applications a feedforward capacitor (C_{ff}) in the range of 4.7 pF to 47 pF (typical) is added in parallel with R_1 to speed up the comparator. Choose a capacitor value that is high enough that the device turns on the PMOS for its minimum on-time with no load at the output.

Selecting the Input Capacitor

The input capacitor is used to reduce peak currents drawn from the power source and reduces noise and voltage ripple on the input of the converter, caused by its switching action. Use low ESR tantalum capacitors or preferably X5R or X7R ceramic capacitors with a voltage rating higher than the maximum supply voltage in the application. In continuous conduction mode, the input capacitor must handle an rms-current which is given by:

$$I_{Cin(rms)} \approx I_O \sqrt{\frac{V_O}{V_{I, \text{min}}}} \quad (6)$$

Select the input capacitor according to the calculated rms-input current requirements and according to the maximum voltage ripple. Use a minimum value of $10 \text{ }\mu\text{F}$:

$$C_{I, \text{min}} = \frac{\frac{1}{2} L \times (\Delta I_L)^2}{V_{(ripple)} \times V_I} \approx \frac{\frac{1}{2} L \times (0.3 \times I_O)^2}{V_{(ripple)} \times V_I} \quad \text{with: } V_{(ripple)} \text{ — voltage ripple at } C_I \quad \Delta I_L \text{ — inductor current ripple} \quad (7)$$

For a first approximation use:

$$L = 10 \mu\text{H}$$

$$V_{(\text{ripple})} = 150 \text{ mV (verify in the application)}$$

Selecting the Inductor Value

The main parameters when choosing the inductor are current rating and inductance. The inductance mainly determines the inductor current ripple. The TPS6420x operates with a wide range of inductor values. Values between 4.7 μH and 47 μH work in most applications. Select an inductor with a current rating exceeding the limit set by $R_{(\text{ISENSE})}$ or $r_{\text{DS(on)}}$. The first step in inductor design is to determine the operating mode of the TPS64200. The device can either work with minimum-on-time or minimum-off-time, depending on input voltage and output voltage.

The device works with minimum-on-time if:

$$V_I - V_O - I_O \times r_{\text{DS(on)}} - R_{\text{RL}} \times I_O \geq \frac{t_{\text{off, min}} \times (V_O + V_{\text{SCHOTTKY}} + R_{\text{RL}} \times I_O)}{t_{\text{on, min}}} \quad (8)$$

with R_{RL} – inductor resistance

$$\text{with } L = \frac{V \times \Delta t}{\Delta I}$$

For minimum-on-time:

$$L = \frac{(V_I - V_O - I_O \times r_{\text{DS(on)}} - R_{\text{RL}} \times I_O) \times t_{\text{on, min}}}{\Delta I} \quad \text{with: } \Delta I \leq 0.3 \times I_O \quad (9)$$

For minimum-off-time:

$$L = \frac{(V_O + V_{\text{SCHOTTKY}} + R_{\text{RL}} \times I_O) \times t_{\text{off, min}}}{\Delta I} \quad (10)$$

Table 1. List of Inductors Tested With the TPS6420x

| MANUFACTURER | TYPE | INDUCTANCE | DC RESISTANCE | SATURATION CURRENT |
|--------------|------------------|---------------------------|------------------------------|--------------------|
| TDK | SLF7032T-100M1R4 | 10 $\mu\text{H} \pm 20\%$ | 53 $\text{m}\Omega \pm 20\%$ | 1.4 A |
| TDK | SLF6025-150MR88 | 15 $\mu\text{H} \pm 20\%$ | 85 $\text{m}\Omega \pm 20\%$ | 0.88 A |
| Sumida | CDRH6D28-5R0 | 5 μH | 23 $\text{m}\Omega$ | 2.4 A |
| Sumida | CDRH103R-100 | 10 μH | 45 $\text{m}\Omega$ | 2.4 A |
| Sumida | CDRH4D28-100 | 10 μH | 95 $\text{m}\Omega$ | 1.0 A |
| Sumida | CDRH5D18-6R2 | 6.2 μH | 71 $\text{m}\Omega$ | 1.4 A |
| Coilcraft | DO3316P-472 | 4.7 μH | 18 $\text{m}\Omega$ | 5.4 A |
| Coilcraft | DT3316P-153 | 15 μH | 60 $\text{m}\Omega$ | 1.8 A |
| Coilcraft | DT3316P-223 | 22 μH | 84 $\text{m}\Omega$ | 1.5 A |
| Würth | 744 052 006 | 6.2 μH | 80 $\text{m}\Omega$ | 1.45 A |
| Würth | 74451115 | 15 μH | 90 $\text{m}\Omega$ | 0.8 A |

Selecting the External PMOS

An external PMOS must be used for a step-down converter with the TPS64200. The selection criteria for the PMOS are threshold voltage, $r_{DS(on)}$, gate charge and current and voltage rating. Since the TPS64200 can operate down to 1.8 V, the external PMOS must have a $V_{GS(th)}$ much lower than that if it is operated with such a low voltage. As the gate of the PMOS finds the full supply voltage applied to the TPS64200, the PMOS must be able to handle that voltage at the gate. The drain to source breakdown voltage rating should be at least a few volts higher than the supply voltage in the application. The rms-current in the PMOS assuming low inductor current ripple and continuous conduction mode, is:

$$I_{PMOS(rms)} \approx I_O \sqrt{D} = I_O \sqrt{\frac{V_O}{V_I}} \quad (11)$$

The power dissipated in the PMOS is comprised of conduction losses and switching losses. The conduction losses are a function of the rms-current in the PMOS and the $r_{DS(on)}$ at a given temperature. They are calculated using:

$$P_{(cond)} = (I_O \sqrt{D})^2 \times r_{DS(on)} \times \left(1 + TC \times [T_J - 25^\circ C]\right) \approx (I_O \sqrt{D})^2 \times r_{DS(on)} \quad (12)$$

with $TC = 0.005/^\circ C$

Table 2. PMOS Transistors Used in the Application Section

| TYPE | MANUFACTURER | $r_{DS(on)}$ | VDS | ID | PACKAGE |
|-----------|------------------|--------------------------------|-------|----------------|---------|
| Si5447DC | Vishay Siliconix | 0.11 Ω at VGS = -2.5 V | -20 V | -3.5 A at 25°C | 1206 |
| Si5475DC | Vishay Siliconix | 0.041 Ω at VGS = -2.5 V | -12 V | -6.6 A at 25°C | 1206 |
| Si2301ADS | Vishay Siliconix | 0.19 Ω at VGS = -2.5 V | -20 V | -1.4 A at 25°C | SOT23 |
| Si2323DS | Vishay Siliconix | 0.41 Ω at VGS = -2.5 V | -20 V | -4.1 A at 25°C | SOT23 |
| FDG326P | Fairchild | 0.17 Ω at VGS = -2.5 V | -20 V | -1.5 A | SC70 |

Selecting the Output Diode

The output diode conducts in the *off* phase of the PMOS and carries the full output current. The high switching frequency demands a high-speed rectifier. Schottky diodes are recommended for best performance. Make sure that the peak current rating of the diode exceeds the peak current limit set by the sense resistor $R_{(ISENSE)}$ or $r_{DS(on)}$. Select a Schottky diode with a low reverse leakage current to avoid an increased supply current. The average current in the diode in continuous conduction mode, assuming low inductor current ripple, is:

$$I_{(diode)(Avg)} \approx I_O(1-D) = I_O \left(1 - \frac{V_O}{V_I}\right) \quad (13)$$

Table 3. Tested Diodes

| TYPE | MANUFACTURER | VR | IF | PACKAGE |
|------------|------------------|------|-------|---------|
| MBRM120LT3 | On Semiconductor | 20 V | 1 A | DO216AA |
| MBR0530T1 | On Semiconductor | 30 V | 0.5 A | SOD123 |
| ZHCS2000TA | Zetex | 40 V | 2 A | SOT23-6 |
| B320 | Diodes Inc. | 20 V | 3 A | SMA |

Selecting the Output Capacitor

The value of the output capacitor depends on the output voltage ripple requirements as well as the maximum voltage deviation during a load transient. The TPS6420x require a certain ESR value for proper operation. Low ESR tantalum capacitors or PosCap work best in the application. A ceramic capacitor with up to 1 μF may be used in parallel for filtering short spikes. The output voltage ripple is a function of both the output capacitance and the ESR value of the capacitor. For a switching frequency which is used with the TPS6420x, the voltage ripple is typically between 90% and 95% due to the ESR value.

$$\Delta V_{pp} = \Delta I \times \left[\text{ESR} + \left(\frac{1}{8 \times C_O \times f} \right) \right] \approx 1.1 \Delta I \times \text{ESR} \quad (14)$$

$$\text{ESR, max} \approx \frac{\Delta V_{pp}}{1.1 \times \Delta I} \quad (15)$$

The output capacitance typically increases with load transient requirements. For a load step from zero output current to its maximum, the following equation can be used to calculate the output capacitance:

$$C_O = \frac{L \times \Delta I_O^2}{(V_I - V_O) \times \Delta V} \quad (16)$$

Table 4. Capacitors Used in the Application

| TYPE | MANUFACTURER | CAPACITANCE | ESR | VOLTAGE RATING |
|------------------|--------------|-------------------|----------------|----------------|
| 6TPB47M (PosCap) | Sanyo | 47 μF | 0.1 Ω | 6.3 V |
| T491D476M010AS | Kemet | 47 μF | 0.8 Ω | 10 V |
| B45197A | Epcos | 47 μF | 0.175 Ω | 16 V |
| B45294-R1107-M40 | Epcos | 100 μF | 0.045 Ω | 6.3 V |
| 594D476X0016C2 | Vishay | 47 μF | 0.11 Ω | 16 V |

Output Voltage Ripple

Output voltage ripple causes the output voltage to be higher or lower than set by the resistor divider at the feedback pin. If the application runs with minimum on-time, the ripple (half of the peak-to-peak value) adds to the output voltage. In an application which runs with minimum off-time, the output voltage is lower by the amount of ripple (half of the peak-to-peak value) at the output.

Snubber Design

For low output current, the TPS6420x work in discontinuous current mode. When the current in the inductor drops to zero, the inductor and parasitic capacitance form a resonant circuit, which causes oscillations when both, diode and PMOS do not conduct at the end of each switching cycle. The oscillation can easily be damped by a RC-snubber. The first step in the snubber design is to measure the oscillation frequency of the sine wave. Then, a capacitor has to be connected in parallel to the Schottky diode which causes the frequency to drop to half of its original value. The resistor is selected for optimum transient response (aperiodic).

$$R = 2\pi fL \quad \begin{array}{l} f - \text{measured resonant frequency} \\ L - \text{inductance used} \end{array} \quad (17)$$

Selecting the Right Device for the Application

The TPS6420x step-down controllers either operate with a fixed on-time or a fixed off-time control. It mainly depends on the input voltage to output voltage ratio if the switching frequency is determined by the minimum-on-time or the minimum-off-time. To select the right device for an application see the table below:

| INPUT TO OUTPUT VOLTAGE RATIO | SWITCHING FREQUENCY DETERMINED BY | PROPOSED DEVICE FOR HIGH SWITCHING FREQUENCY | PROPOSED DEVICE FOR LOW SWITCHING FREQUENCY |
|---|-----------------------------------|--|---|
| $V_I \gg V_O$ (e.g. $V_I = 5\text{ V}$ $V_O = 1.5\text{ V}$) | Minimum on-time | TPS64203 | TPS64200, TPS64201 |
| $V_I \approx V_O$ (e.g. $V_I = 3.8\text{ V}$ $V_O = 3.3\text{ V}$) | Minimum off-time | TPS64202 | TPS64200, TPS64201 |

APPLICATION INFORMATION

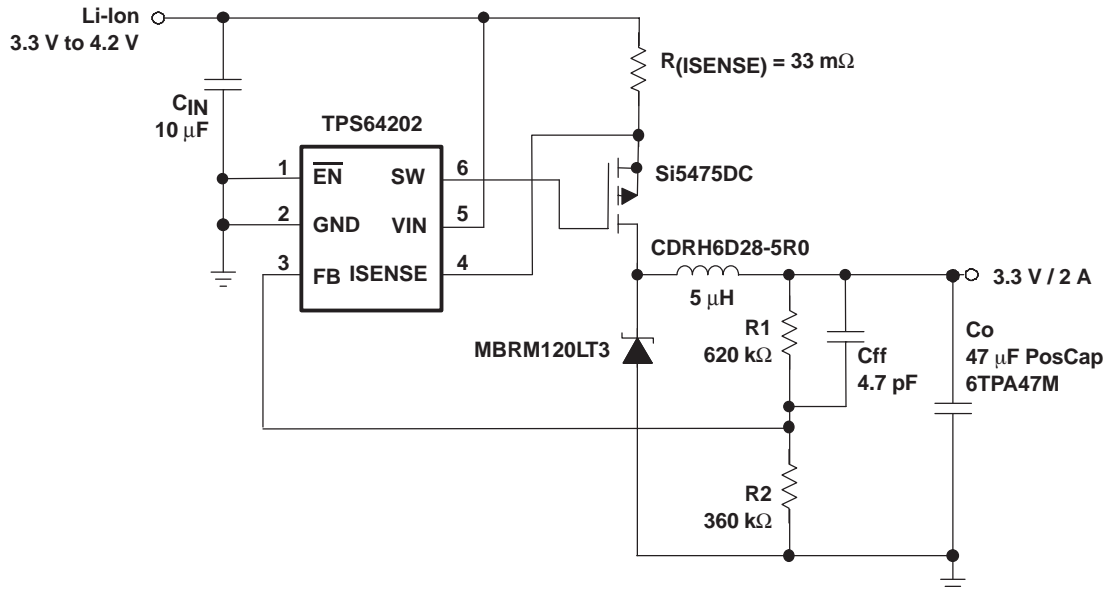

Figure 19. Application For a Li-Ion to 3.3-V / 2-A Conversion

The TPS64202 was used for this application because for a low input to output voltage difference, the switching frequency is determined by the minimum off-time. The TPS64202 with its minimum off-time of 300 ns provides a higher switching frequency compared to the other members of the TPS6420x family.

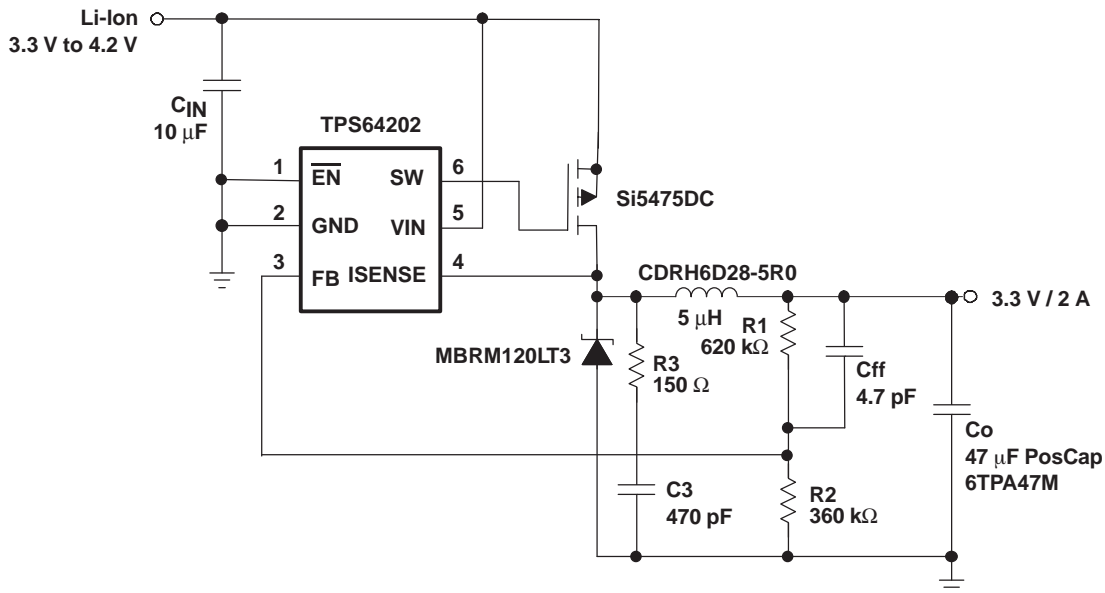

Figure 20. Application For a Li-Ion to 3.3-V / 2-A Conversion Using $r_{DS(on)}$ Sense and RC Snubber Network For the Schottky Diode

DESIGN EXAMPLE FOR AN APPLICATION USING A LI-ION CELL (3.3 V TO 4.2 V) TO GENERATE 3.3 V/500 mA

1. Calculate the sense resistor for the current limit:

$$R_{(ISENSE)} \leq \frac{V_{(ISENSE)}^{\min}}{1.3 \times I_O} = \frac{90 \text{ mV}}{1.3 \times 0.5 \text{ A}} = 138 \text{ m}\Omega \quad (18)$$

Choose the next lower standard value : $R_{(ISENSE)} = 120 \text{ m}\Omega$. Verify the inductor current ripple after the inductor has been determined in step 5.

If the $r_{DS(on)}$ of the PMOS is used to sense the inductor current, a PMOS with less than $138 \text{ m}\Omega$ must be used for the application.

2. Calculate the resistors for the output voltage divider using $V_O = 3.3 \text{ V}$ and $V_{FB} = 1.21 \text{ V}$

$$R1 = R2 \times \left(\frac{V_O}{V_{FB}} \right) - R2 = 1.72 \times R2 \quad (19)$$

Choose $R2 = 360 \text{ k}\Omega$, and then get $R1 = 619 \text{ k}\Omega$. Select the next standard value: $R1 = 620 \text{ k}\Omega$

3. Select the external PMOS

For a Li-Ion to 3.3-V conversion, the minimum input voltage is 3.3 V. Therefore, the converter runs in 100% mode (duty cycle=1) and the maximum PMOS current is equal to the output current.

$$I_{(PMOS)} = I_O = 0.5 \text{ A} \quad (20)$$

The Si2301ADS is selected for this application because it meets the requirements when an external sense resistor is used. Otherwise a PMOS with less $r_{DS(on)}$ must be selected.

Verify the maximum power dissipation of the PMOS using:

$$P_{(cond)} = (I_O)^2 \times r_{DS(on)} = (0.5 \text{ A})^2 \times 0.19 \text{ }\Omega = 48 \text{ mW} \quad (21)$$

4. Select the external diode

For the Schottky diode, the worst case current is at high input voltage (4.2 V for a Li-Ion cell).

$$I_{(diode)(Avg)} \approx I_O \left(1 - \frac{V_O}{V_I} \right) = I_O \left(1 - \frac{3.3 \text{ V}}{4.2 \text{ V}} \right) = 0.11 \text{ A} \quad (22)$$

The MBR0530T1 is selected because it meets the voltage and current requirements. The forward voltage is about 0.3 V. Do not use a Schottky diode which is much larger than required as it also typically has more leakage current and capacitance which reduces efficiency.

5. Calculate the inductor value.

If the output voltage is close to the input voltage, the switching frequency is determined by the minimum off-time. Therefore, the TPS64202 is used for the maximum switching frequency possible. Allow an inductor ripple current of $0.3 \times I_O$ for the application. For the inductor, a series resistance of $100 \text{ m}\Omega$ is assumed.

For minimum-off-time, the inductor value is:

$$L = \frac{(V_O + V_{(SCHOTTKY)} + R_{RL} \times I_O) \times t_{off, \min}}{\Delta I} = \frac{(3.3 \text{ V} + 0.3 \text{ V} + 0.05 \text{ V}) \times 0.3 \text{ }\mu\text{s}}{0.3 \times 0.5 \text{ A}} = 7.3 \text{ }\mu\text{H} \quad (23)$$

For a low inductor current ripple, select the next available larger inductor with $L = 10 \text{ }\mu\text{H}$. This provides an inductor ripple current of 110 mA (peak-to-peak).

$$\Delta I = \frac{(V_O + V_{(SCHOTTKY)} + R_{RL} \times I_O) \times t_{off, \min}}{L} = 110 \text{ mA} \quad (24)$$

The current rating for the inductor must be:

$$I_{\text{inductor}} > I_O + \frac{\Delta I}{2} = 555 \text{ mA} \quad (25)$$

6. Select the input and output capacitor

The output capacitor is selected for an output voltage ripple of less than 20 mVpp.

With

$$ESR, \max \approx \frac{\Delta V_{pp}}{1.1 \times \Delta I} = \frac{0.02 \text{ V}}{1.1 \times 0.11 \text{ A}} = 165 \text{ m}\Omega \quad (26)$$

A 47- μF PosCap with an ESR of 100 m Ω was selected to meet the ripple requirements.

The input capacitor was selected to its minimum value of 10 μF .

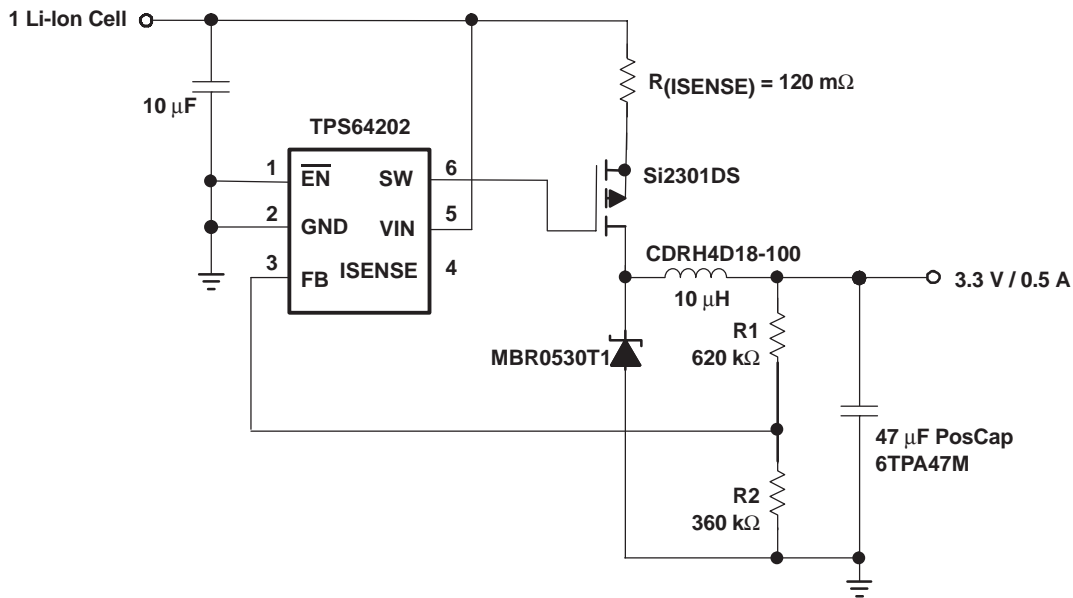

Figure 21. Application Circuit

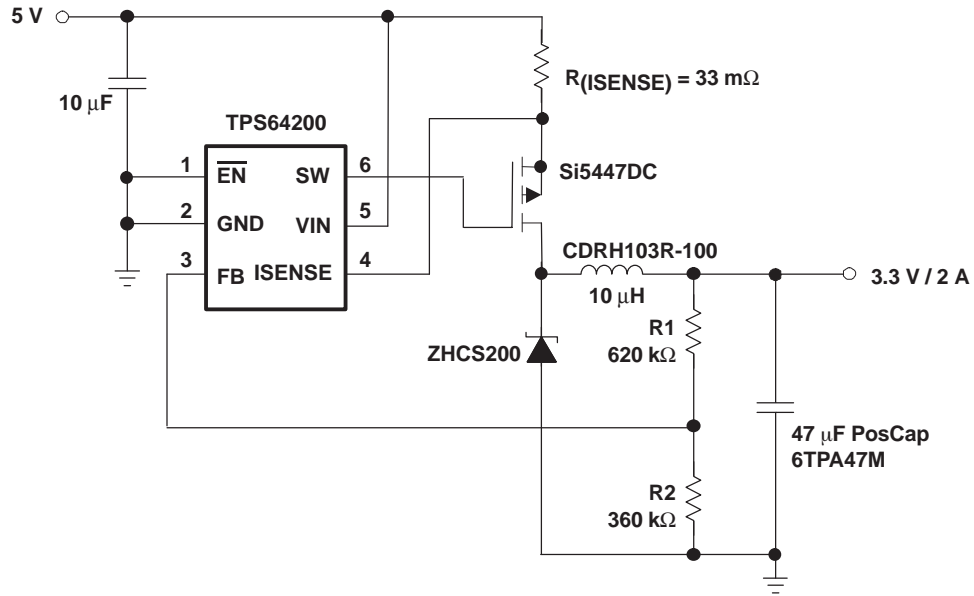

Figure 22. Application For a 5-V to 3.3-V / 2-A Conversion

Inverter Using TPS64200

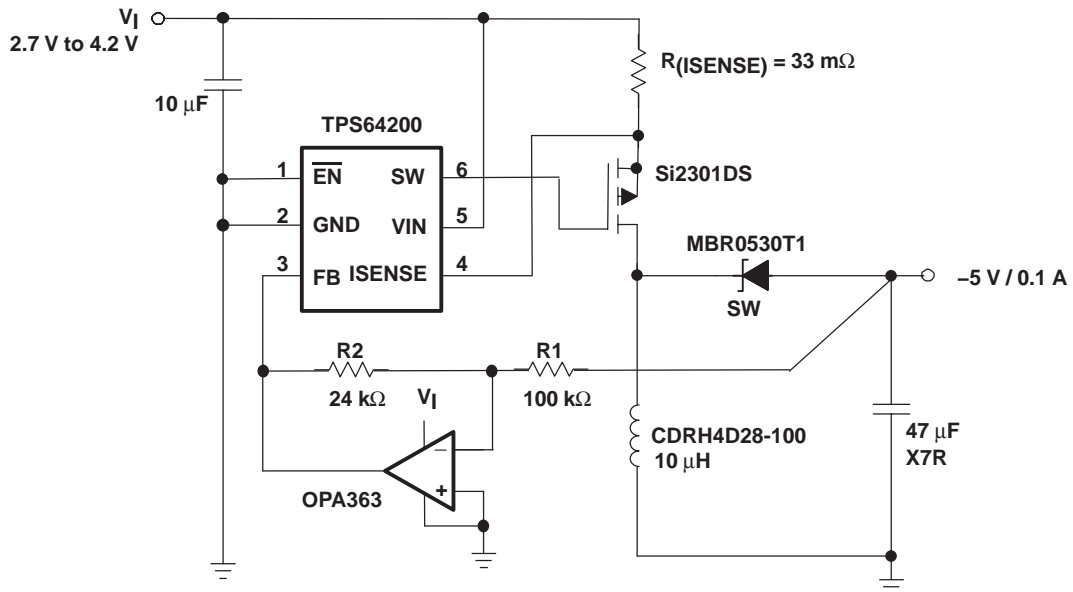

Figure 23. Application For an Inverter Using TPS64200

The TPS6420x can be used for an inverter. Only one additional operational amplifier is required for this application. When the PMOS is switched on, the current in the inductor ramps up to its maximum, set by R_s . Then the PMOS is switched off, the energy stored in the inductor is transferred to the output. The output voltage and the maximum output current can be calculated using:

$$V_O = \frac{R_1}{R_2} \times V_{FB} \quad I_{O \max} \approx 0.8 \times \frac{V_I}{-V_O} \times \frac{V_{(ISENSE)}}{2R_{(ISENSE)}} \quad (27)$$

OLED Power Supply

The TPS6420x can be combined with a TPS61045 boost converter for a OLED power supply.

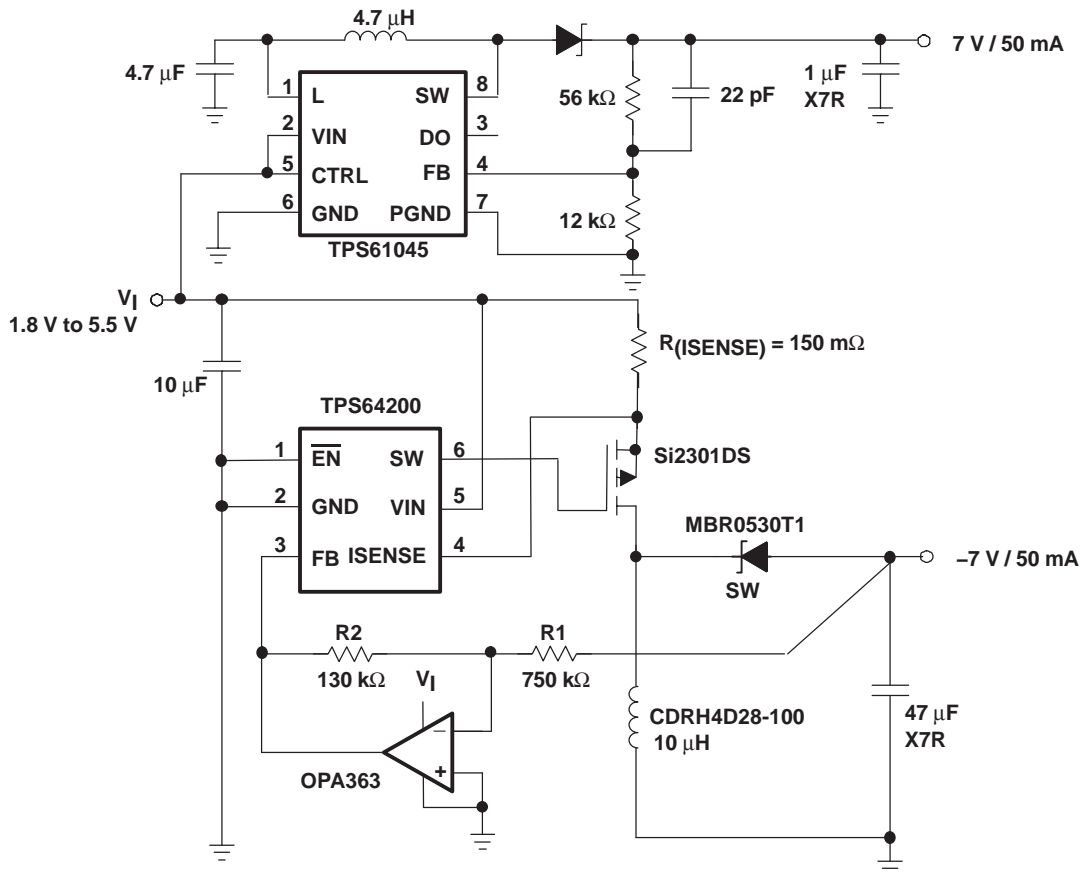

Figure 24. Application For a OLED Power Supply

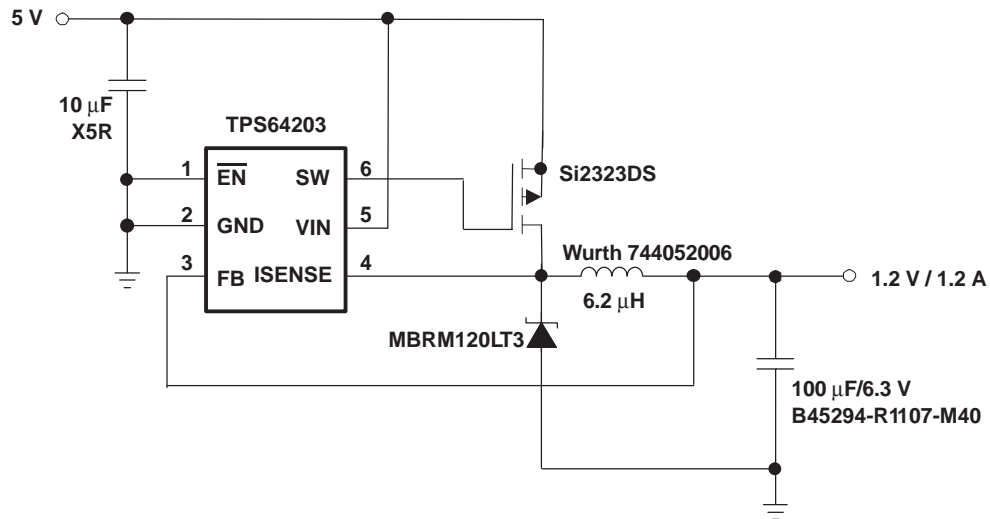

Figure 25. Application For a 5-V to 1.2-V / 1.2-A Conversion

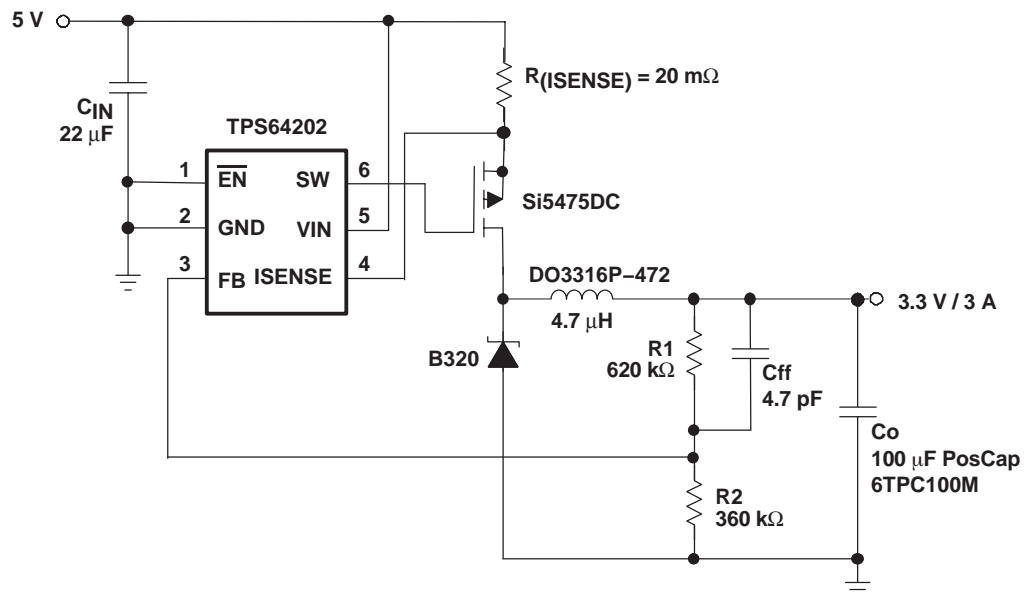

Figure 26. Application For a 5-V to 3.3-V / 3-A Conversion

Ceramic Output Capacitor

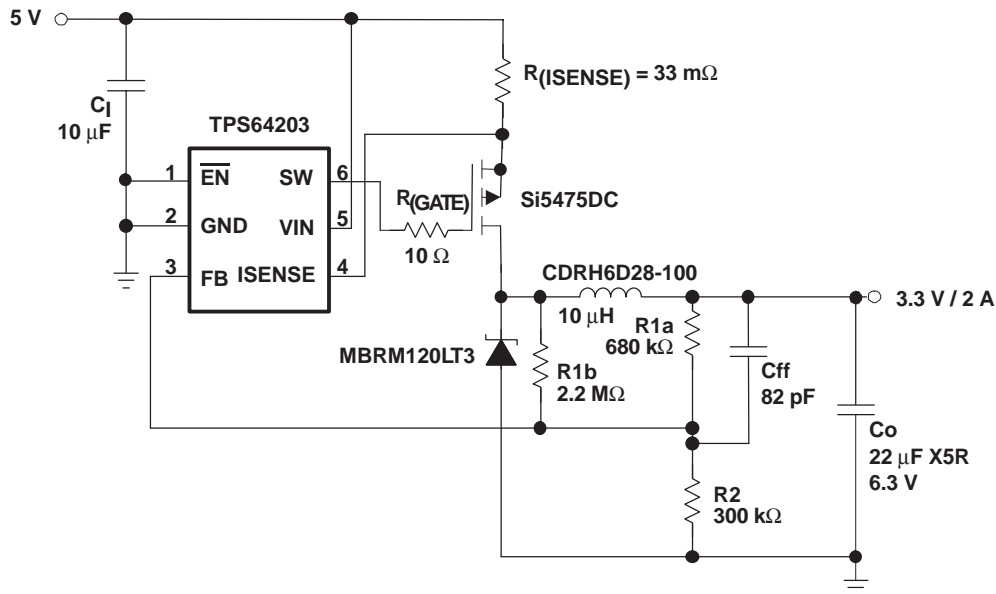

Figure 27. Application Using a Ceramic Output Capacitor

The control scheme of the TPS6420x usually requires an output capacitor with some tens of milliohms of ESR for stability, which is usually the case for tantalum capacitors. This application circuit above also works with ceramic capacitors. Resistor R1b is used to add an additional control signal to the feedback loop, which is coupled into the FB pin. The circuit works best with $R1b = 2 \dots 4 \times R1a$. If the resistance of R1b is too low compared to R1a, the more load regulation the output voltage shows, but stability is best. The advantage of this circuit is a very low output voltage ripple and small size. The gate resistor shown can be used in every application. It minimizes switching noise of the converter and, therefore, increases stability and provides lower output voltage ripple. However, it decreases efficiency slightly because the rise and fall time, and the associated losses are larger.

$$R1 = \frac{1}{\frac{1}{R1a} + \frac{1}{R1b}} \quad R1b = \frac{1}{\frac{1}{R1} - \frac{1}{R1a}} \quad (28)$$

Use the following equation to calculate R1a if $R1b = 4R1a$

$$R1a = \frac{5}{4} R1 \quad (29)$$

PACKAGING INFORMATION

| Orderable Device | Status (1) | Package Type | Package Drawing | Pins | Package Qty | Eco Plan (2) | Lead finish/ Ball material (6) | MSL Peak Temp (3) | Op Temp (°C) | Device Marking (4/5) | Samples |
|------------------|---------------|--------------|-----------------|------|-------------|-----------------|--------------------------------------|----------------------|--------------|-------------------------|-------------------------|
| TPS64200DBVR | ACTIVE | SOT-23 | DBV | 6 | 3000 | RoHS & Green | NIPDAU | Level-1-260C-UNLIM | -40 to 85 | PJAI | Samples |
| TPS64200DBVT | ACTIVE | SOT-23 | DBV | 6 | 250 | RoHS & Green | NIPDAU | Level-1-260C-UNLIM | -40 to 85 | PJAI | Samples |
| TPS64200DBVTG4 | ACTIVE | SOT-23 | DBV | 6 | 250 | RoHS & Green | NIPDAU | Level-1-260C-UNLIM | -40 to 85 | PJAI | Samples |
| TPS64201DBVR | ACTIVE | SOT-23 | DBV | 6 | 3000 | RoHS & Green | NIPDAU | Level-1-260C-UNLIM | -40 to 85 | PJBI | Samples |
| TPS64201DBVT | ACTIVE | SOT-23 | DBV | 6 | 250 | RoHS & Green | NIPDAU | Level-1-260C-UNLIM | -40 to 85 | PJBI | Samples |
| TPS64202DBVR | ACTIVE | SOT-23 | DBV | 6 | 3000 | RoHS & Green | NIPDAU | Level-1-260C-UNLIM | -40 to 85 | PJCI | Samples |
| TPS64202DBVT | ACTIVE | SOT-23 | DBV | 6 | 250 | RoHS & Green | NIPDAU | Level-1-260C-UNLIM | -40 to 85 | PJCI | Samples |
| TPS64203DBVR | ACTIVE | SOT-23 | DBV | 6 | 3000 | RoHS & Green | NIPDAU | Level-1-260C-UNLIM | -40 to 85 | PJDI | Samples |
| TPS64203DBVT | ACTIVE | SOT-23 | DBV | 6 | 250 | RoHS & Green | NIPDAU | Level-1-260C-UNLIM | -40 to 85 | PJDI | Samples |
| TPS64203DBVTG4 | ACTIVE | SOT-23 | DBV | 6 | 250 | RoHS & Green | NIPDAU | Level-1-260C-UNLIM | -40 to 85 | PJDI | Samples |

(1) The marketing status values are defined as follows:

ACTIVE: Product device recommended for new designs.

LIFEBUY: TI has announced that the device will be discontinued, and a lifetime-buy period is in effect.

NRND: Not recommended for new designs. Device is in production to support existing customers, but TI does not recommend using this part in a new design.

PREVIEW: Device has been announced but is not in production. Samples may or may not be available.

OBSOLETE: TI has discontinued the production of the device.

(2) **RoHS:** TI defines "RoHS" to mean semiconductor products that are compliant with the current EU RoHS requirements for all 10 RoHS substances, including the requirement that RoHS substance do not exceed 0.1% by weight in homogeneous materials. Where designed to be soldered at high temperatures, "RoHS" products are suitable for use in specified lead-free processes. TI may reference these types of products as "Pb-Free".

RoHS Exempt: TI defines "RoHS Exempt" to mean products that contain lead but are compliant with EU RoHS pursuant to a specific EU RoHS exemption.

Green: TI defines "Green" to mean the content of Chlorine (Cl) and Bromine (Br) based flame retardants meet JS709B low halogen requirements of <=1000ppm threshold. Antimony trioxide based flame retardants must also meet the <=1000ppm threshold requirement.

(3) MSL, Peak Temp. - The Moisture Sensitivity Level rating according to the JEDEC industry standard classifications, and peak solder temperature.

(4) There may be additional marking, which relates to the logo, the lot trace code information, or the environmental category on the device.

⁽⁵⁾ Multiple Device Markings will be inside parentheses. Only one Device Marking contained in parentheses and separated by a "~" will appear on a device. If a line is indented then it is a continuation of the previous line and the two combined represent the entire Device Marking for that device.

⁽⁶⁾ Lead finish/Ball material - Orderable Devices may have multiple material finish options. Finish options are separated by a vertical ruled line. Lead finish/Ball material values may wrap to two lines if the finish value exceeds the maximum column width.

Important Information and Disclaimer:The information provided on this page represents TI's knowledge and belief as of the date that it is provided. TI bases its knowledge and belief on information provided by third parties, and makes no representation or warranty as to the accuracy of such information. Efforts are underway to better integrate information from third parties. TI has taken and continues to take reasonable steps to provide representative and accurate information but may not have conducted destructive testing or chemical analysis on incoming materials and chemicals. TI and TI suppliers consider certain information to be proprietary, and thus CAS numbers and other limited information may not be available for release.

In no event shall TI's liability arising out of such information exceed the total purchase price of the TI part(s) at issue in this document sold by TI to Customer on an annual basis.

TAPE AND REEL INFORMATION



QUADRANT ASSIGNMENTS FOR PIN 1 ORIENTATION IN TAPE



*All dimensions are nominal

| Device | Package Type | Package Drawing | Pins | SPQ | Reel Diameter (mm) | Reel Width W1 (mm) | A0 (mm) | B0 (mm) | K0 (mm) | P1 (mm) | W (mm) | Pin1 Quadrant |
|--------------|--------------|-----------------|------|------|--------------------|--------------------|---------|---------|---------|---------|--------|---------------|
| TPS64200DBVR | SOT-23 | DBV | 6 | 3000 | 178.0 | 9.0 | 3.23 | 3.17 | 1.37 | 4.0 | 8.0 | Q3 |
| TPS64200DBVT | SOT-23 | DBV | 6 | 250 | 178.0 | 9.0 | 3.23 | 3.17 | 1.37 | 4.0 | 8.0 | Q3 |
| TPS64201DBVR | SOT-23 | DBV | 6 | 3000 | 179.0 | 8.4 | 3.2 | 3.2 | 1.4 | 4.0 | 8.0 | Q3 |
| TPS64201DBVT | SOT-23 | DBV | 6 | 250 | 178.0 | 9.0 | 3.23 | 3.17 | 1.37 | 4.0 | 8.0 | Q3 |
| TPS64201DBVR | SOT-23 | DBV | 6 | 3000 | 178.0 | 9.0 | 3.23 | 3.17 | 1.37 | 4.0 | 8.0 | Q3 |
| TPS64201DBVT | SOT-23 | DBV | 6 | 250 | 179.0 | 8.4 | 3.2 | 3.2 | 1.4 | 4.0 | 8.0 | Q3 |
| TPS64202DBVR | SOT-23 | DBV | 6 | 3000 | 178.0 | 9.0 | 3.23 | 3.17 | 1.37 | 4.0 | 8.0 | Q3 |
| TPS64202DBVT | SOT-23 | DBV | 6 | 250 | 178.0 | 9.0 | 3.23 | 3.17 | 1.37 | 4.0 | 8.0 | Q3 |
| TPS64203DBVR | SOT-23 | DBV | 6 | 3000 | 178.0 | 9.0 | 3.23 | 3.17 | 1.37 | 4.0 | 8.0 | Q3 |
| TPS64203DBVT | SOT-23 | DBV | 6 | 250 | 178.0 | 9.0 | 3.23 | 3.17 | 1.37 | 4.0 | 8.0 | Q3 |

TAPE AND REEL BOX DIMENSIONS

*All dimensions are nominal

| Device | Package Type | Package Drawing | Pins | SPQ | Length (mm) | Width (mm) | Height (mm) |
|--------------|--------------|-----------------|------|------|-------------|------------|-------------|
| TPS64200DBVR | SOT-23 | DBV | 6 | 3000 | 180.0 | 180.0 | 18.0 |
| TPS64200DBVT | SOT-23 | DBV | 6 | 250 | 180.0 | 180.0 | 18.0 |
| TPS64201DBVR | SOT-23 | DBV | 6 | 3000 | 200.0 | 183.0 | 25.0 |
| TPS64201DBVR | SOT-23 | DBV | 6 | 3000 | 180.0 | 180.0 | 18.0 |
| TPS64201DBVT | SOT-23 | DBV | 6 | 250 | 180.0 | 180.0 | 18.0 |
| TPS64201DBVT | SOT-23 | DBV | 6 | 250 | 200.0 | 183.0 | 25.0 |
| TPS64202DBVR | SOT-23 | DBV | 6 | 3000 | 180.0 | 180.0 | 18.0 |
| TPS64202DBVT | SOT-23 | DBV | 6 | 250 | 180.0 | 180.0 | 18.0 |
| TPS64203DBVR | SOT-23 | DBV | 6 | 3000 | 180.0 | 180.0 | 18.0 |
| TPS64203DBVT | SOT-23 | DBV | 6 | 250 | 180.0 | 180.0 | 18.0 |

EXAMPLE BOARD LAYOUT

DBV0006A

SOT-23 - 1.45 mm max height

SMALL OUTLINE TRANSISTOR

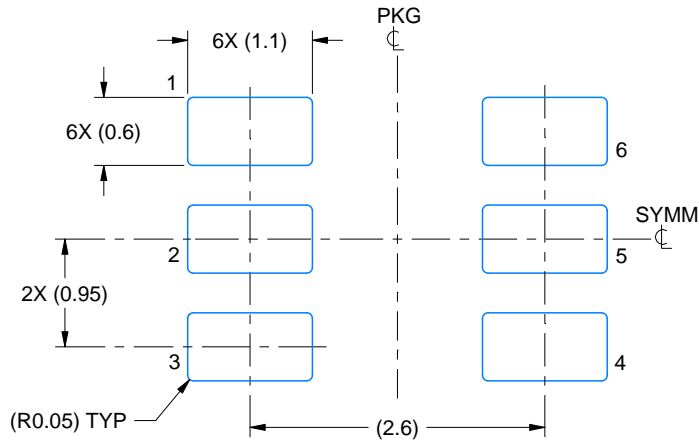

LAND PATTERN EXAMPLE
EXPOSED METAL SHOWN
SCALE:15X

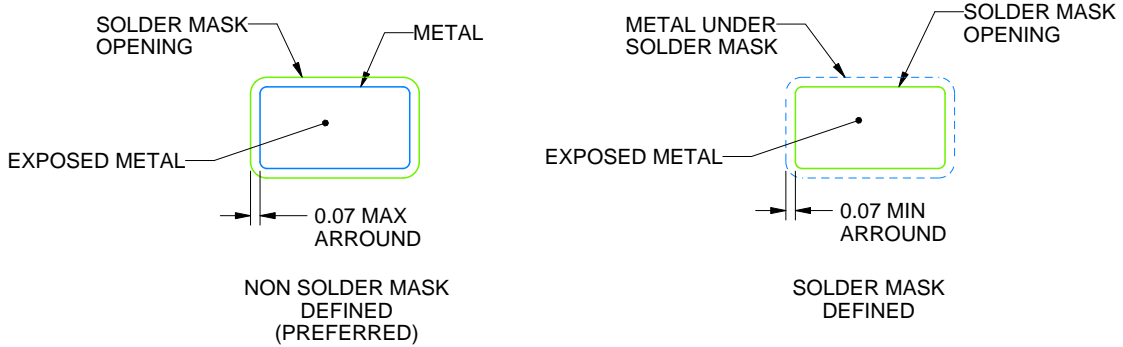

SOLDER MASK DETAILS

4214840/E 02/2024

NOTES: (continued)

- 6. Publication IPC-7351 may have alternate designs.
- 7. Solder mask tolerances between and around signal pads can vary based on board fabrication site.

EXAMPLE STENCIL DESIGN

DBV0006A

SOT-23 - 1.45 mm max height

SMALL OUTLINE TRANSISTOR

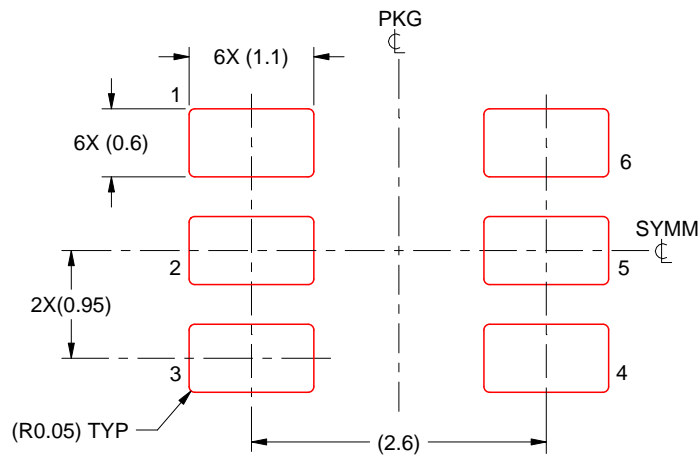

SOLDER PASTE EXAMPLE
BASED ON 0.125 mm THICK STENCIL
SCALE:15X

4214840/E 02/2024

NOTES: (continued)

8. Laser cutting apertures with trapezoidal walls and rounded corners may offer better paste release. IPC-7525 may have alternate design recommendations.
9. Board assembly site may have different recommendations for stencil design.

IMPORTANT NOTICE AND DISCLAIMER

TI PROVIDES TECHNICAL AND RELIABILITY DATA (INCLUDING DATA SHEETS), DESIGN RESOURCES (INCLUDING REFERENCE DESIGNS), APPLICATION OR OTHER DESIGN ADVICE, WEB TOOLS, SAFETY INFORMATION, AND OTHER RESOURCES "AS IS" AND WITH ALL FAULTS, AND DISCLAIMS ALL WARRANTIES, EXPRESS AND IMPLIED, INCLUDING WITHOUT LIMITATION ANY IMPLIED WARRANTIES OF MERCHANTABILITY, FITNESS FOR A PARTICULAR PURPOSE OR NON-INFRINGEMENT OF THIRD PARTY INTELLECTUAL PROPERTY RIGHTS.

These resources are intended for skilled developers designing with TI products. You are solely responsible for (1) selecting the appropriate TI products for your application, (2) designing, validating and testing your application, and (3) ensuring your application meets applicable standards, and any other safety, security, regulatory or other requirements.

These resources are subject to change without notice. TI grants you permission to use these resources only for development of an application that uses the TI products described in the resource. Other reproduction and display of these resources is prohibited. No license is granted to any other TI intellectual property right or to any third party intellectual property right. TI disclaims responsibility for, and you will fully indemnify TI and its representatives against, any claims, damages, costs, losses, and liabilities arising out of your use of these resources.

TI's products are provided subject to [TI's Terms of Sale](#) or other applicable terms available either on [ti.com](https://www.ti.com) or provided in conjunction with such TI products. TI's provision of these resources does not expand or otherwise alter TI's applicable warranties or warranty disclaimers for TI products.

TI objects to and rejects any additional or different terms you may have proposed.

Mailing Address: Texas Instruments, Post Office Box 655303, Dallas, Texas 75265
Copyright © 2024, Texas Instruments Incorporated

Looking for pricing, stock, or lifecycle information?

Click below to explore more details on WIN SOURCE:

 [View TPS64203DBVT on WIN SOURCE](#)

 [Texas Instruments](#) Information

Optimize Your Supply Chain with WIN SOURCE Solutions

-  Global Sourcing Solution
-  Obsolete Management
-  Cost Control Management
-  Shortage Management
-  Alternative Solution
-  Excess Inventory Management