



**THE DATASHEET OF  
TPS65100QPWPRQ1**



## TPS65100-Q1 Triple-Output LCD Supply With Linear Regulator and VCOM Buffer

### 1 Features

- Qualified for Automotive Applications
- AEC-Q100 Qualified With the Following Results:
  - Device Temperature Grade 1: –40°C to 125°C Ambient Operating Temperature Range
  - Device HBM ESD Classification Level 2
  - Device CDM ESD Classification Level C5
- Input Voltage Range: 2.7-V to 5.8-V
- $V_{O1}$  Boost Converter
  - Up to 15 V Output Voltage
  - Virtual Synchronous Converter Topology
  - < 1% Output Voltage Accuracy
  - 1.6-MHz Fixed Switching Frequency
  - 2.3-A Switch Current Limit
- $V_{O2}$  Negative Regulated Charge Pump
  - Down to -12 V / 20 mA
- $V_{O3}$  Positive Regulated Charge Pump
  - Up to 30 V / 20 mA
- Three Independently Adjustable Outputs
- Integrated VCOM Buffer
- Auxiliary 3.3-V Linear Regulator Controller
- Internal Soft Start
- Internal Power-On Sequencing
- Protection Features
  - Short-Circuit Detection of all Outputs
  - Overvoltage Protection of all Outputs
  - Thermal Shutdown
- Available in TSSOP-24 PowerPAD™ Package

### 2 Applications

- Infotainment Systems
- Automotive Displays
- Instrument Clusters
- Center Consoles
- Rear Seat Entertainment

### 3 Description

The TPS65100-Q1 device offers a compact and small power supply solution that provides all three voltages required by thin-film transistor (TFT) LCD displays. The auxiliary linear regulator controller can be used to generate a 3.3-V logic power rail for systems powered by a 5-V supply rail only.

The main output,  $V_{O1}$ , is a 1.6-MHz fixed-frequency PWM boost converter that provides the source-drive voltage for the LCD display. The TPS65100-Q1 has a typical switch current limit of 2.3 A. A fully integrated adjustable charge pump doubler-tripler provides the positive LCD gate-drive voltage. An externally adjustable negative charge pump provides the negative gate-drive voltage.

The TPS65100-Q1 has an integrated VCOM buffer to power the LCD backplane. For LCD panels powered by 5 V only, the TPS65100-Q1 device has a linear regulator controller using an external transistor to provide a regulated 3.3-V output for the digital circuits. For maximum safety, the TPS65100-Q1 device goes into shutdown as soon as one of the outputs is out of regulation. The device can be enabled again by toggling the input or the enable (EN) pin to GND.

#### Device Information<sup>(1)</sup>

PART NUMBER	PACKAGE	BODY SIZE (NOM)
TPS65100-Q1	TSSOP (24) with PowerPAD	4.40 mm × 7.80 mm

(1) For all available packages, see the orderable addendum at the end of the data sheet.

#### TPS65100-Q1 Overview

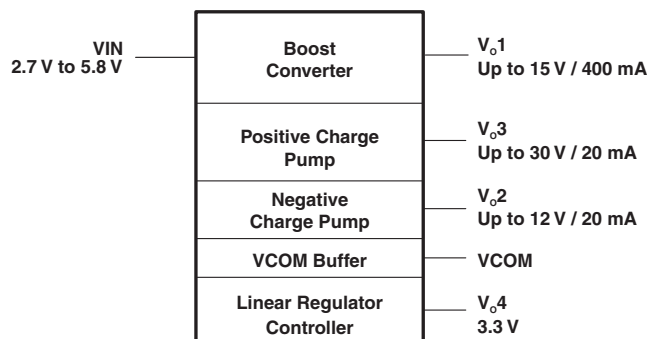

## Table of Contents

<b>1 Features</b> .....	<b>1</b>	7.4 Device Functional Modes.....	<b>12</b>
<b>2 Applications</b> .....	<b>1</b>	<b>8 Application and Implementation</b> .....	<b>13</b>
<b>3 Description</b> .....	<b>1</b>	8.1 Application Information.....	<b>13</b>
<b>4 Revision History</b> .....	<b>2</b>	8.2 Typical Applications .....	<b>14</b>
<b>5 Pin Configuration and Functions</b> .....	<b>4</b>	<b>9 Power Supply Recommendations</b> .....	<b>22</b>
<b>6 Specifications</b> .....	<b>5</b>	<b>10 Layout</b> .....	<b>23</b>
6.1 Absolute Maximum Ratings .....	<b>5</b>	10.1 Layout Guidelines .....	<b>23</b>
6.2 ESD Ratings.....	<b>5</b>	10.2 Layout Example .....	<b>23</b>
6.3 Recommended Operating Conditions.....	<b>5</b>	10.3 Thermal Considerations .....	<b>23</b>
6.4 Thermal Information .....	<b>6</b>	<b>11 Device and Documentation Support</b> .....	<b>24</b>
6.5 Electrical Characteristics.....	<b>6</b>	11.1 Documentation Support .....	<b>24</b>
6.6 Typical Characteristics .....	<b>8</b>	11.2 Community Resources.....	<b>24</b>
<b>7 Detailed Description</b> .....	<b>9</b>	11.3 Trademarks .....	<b>24</b>
7.1 Overview .....	<b>9</b>	11.4 Electrostatic Discharge Caution.....	<b>24</b>
7.2 Functional Block Diagram .....	<b>10</b>	11.5 Glossary .....	<b>24</b>
7.3 Feature Description.....	<b>10</b>	<b>12 Mechanical, Packaging, and Orderable Information</b> .....	<b>24</b>

## 4 Revision History

NOTE: Page numbers for previous revisions may differ from page numbers in the current version.

### Changes from Revision B (March 2016) to Revision C

Page

• Changed Features List .....	<b>1</b>
• Changed from $T_A$ to $T_J$ in the Conditions statement of and changed temperature from 85°C to 125°C.....	<b>6</b>
• Changed the MAIN BOOST CONVERTER $V_{REF}$ spec from 1.205 MIN to 1.198, and MAX from 1.203 to 1.230 .....	<b>6</b>
• Changed $V_{FB}$ spec from 1.113 MIN to 1.126, and MAX from 1.154 to 1.161 .....	<b>6</b>
• Changed $r_{DS(ON)}$ for $V_{O1} = 10$ V, $I_{sw} = 500$ mA condition, from 290 to 325 MAX; and, for the $V_{O1} = 5$ V, $I_{sw} = 500$ mA condition, changed from 420 to 455 MAX.....	<b>6</b>
• Changed $f_{SW}$ Condition from $T_A$ to $T_J$ and changed $f_{SW}$ spec for $0^\circ\text{C} \leq T_J \leq 125^\circ\text{C}$ condition from 1.295 MIN to 1.195 MIN; and, changed the MIN from 1.191 to 1.091, for the $-40^\circ\text{C} \leq T_J \leq 125^\circ\text{C}$ condition; .....	<b>6</b>
• Changed from $T_A$ to $T_J$ in the Conditions statement of and changed temperature from 85°C to 125°C.....	<b>7</b>
• Changed NEGATIVE CHARGE PUMP $V_{O2} V_{REF}$ spec from 1.205 MIN to 1.198, and MAX from 1.219 to 1.226 .....	<b>7</b>
• Changed POSITIVE CHARGE PUMP $V_{O3} V_{REF}$ spec from 1.205 MIN to 1.198, and MAX from 1.219 to 1.226.....	<b>7</b>
• Changed $V_{FB}$ spec from 1.187 MIN to 1.180, and MAX from 1.238 to 1.245 .....	<b>7</b>
• Changed POSITIVE CHARGE PUMP $V_{O3}, V_D$ spec from 720 MAX to 800 .....	<b>7</b>
• Changed from $T_A$ to $T_J$ in the Conditions statement of and changed temperature from 85°C to 125°C.....	<b>8</b>

### Changes from Revision A (April 2012) to Revision B

Page

• Added <i>Device Information</i> table, <i>Pin Configuration and Functions</i> section, <i>Specifications</i> section, <i>Feature Description</i> section, <i>Device Functional Modes</i> section, <i>Application and Implementation</i> section, <i>Power Supply Recommendations</i> section, <i>Layout</i> section, <i>Device and Documentation Support</i> section, and <i>Mechanical, Packaging, and Orderable Information</i> section .....	<b>1</b>
• Deleted <i>Ordering Information</i> table. See <a href="#">Mechanical, Packaging, and Orderable Information</a> for more information. ....	<b>4</b>
• Changed R1 and R2 values .....	<b>17</b>
• Added clarification on linear regulator use for $V_I = 5$ V, but not $V_I = 3.3$ V .....	<b>19</b>

**Changes from Original (July 2008) to Revision A****Page**

- 
- Added thermal table for PWP Package ..... [6](#)
-

## 5 Pin Configuration and Functions

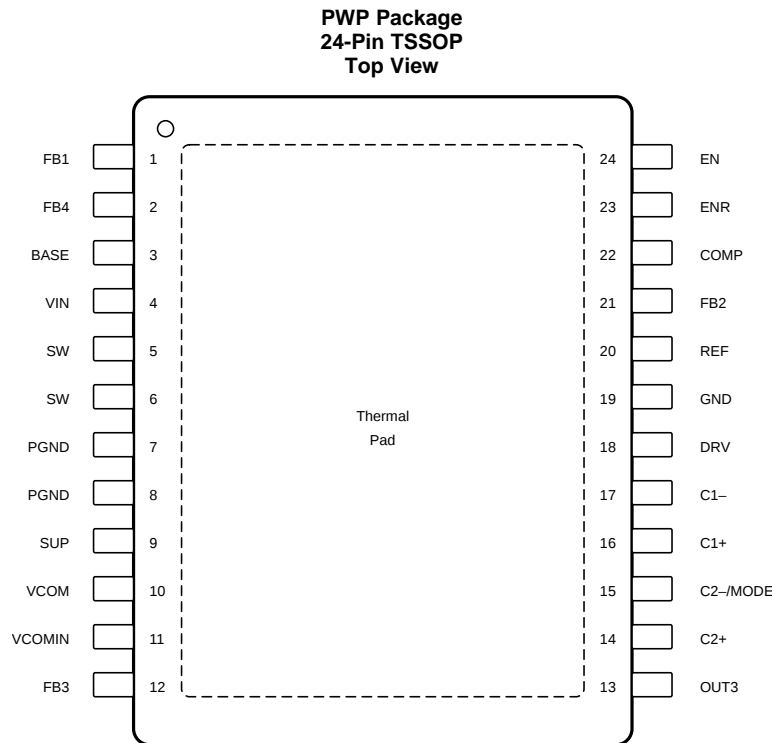

### Pin Functions

PIN		I/O	DESCRIPTION
NAME	NO.		
BASE	3	O	Base drive output for the external transistor
C1+	16	—	Positive terminal of the charge pump flying capacitor
C1-	17	—	Negative terminal of the charge pump flying capacitor
C2+	14	—	Positive terminal for the charge pump flying capacitor. If the device runs in voltage doubler mode, this pin should be left open.
C2-/MODE	15	—	Negative terminal of the charge pump flying capacitor and charge pump MODE pin. If the flying capacitor is connected to this pin, the converter operates in a voltage tripler mode. If the charge pump needs to operate in a voltage doubler mode, the flying capacitor is removed and the C2-/MODE pin should be connected to GND.
COMP	22	—	Compensation pin for the main boost converter. A small capacitor is connected to this pin.
DRV	18	O	External charge pump driver
EN	24	I	Enable pin of the device. This pin should be terminated and not be left floating. A logic high enables the device and a logic low shuts down the device.
ENR	23	I	Enable pin of the linear regulator controller. This pin should be terminated and not be left floating. Logic high enables the regulator and a logic low puts the regulator in shutdown.
FB1	1	I	Feedback pin of the boost converter
FB2	21	I	Feedback pin of negative charge pump
FB3	12	I	Feedback pin of positive charge pump
FB4	2	I	Feedback pin of the linear regulator controller. The linear regulator controller is set to a fixed output voltage of 3.3 V or 3 V depending on the version.
OUT3	13	PWR	Positive charge pump output
REF	20	O	Internal reference output typically 1.23 V
SUP	9	I	Supply of the positive and negative charge pump, boost converter gate-drive circuit, and VCOM buffer. Should be connected to the output of the main boost converter and cannot be connected to any other voltage source. For performance reasons, do not connect a bypass capacitor directly to this pin.

### Pin Functions (continued)

PIN		I/O	DESCRIPTION
NAME	NO.		
SW	5, 6	PWR	Switch pin of the boost converter
VCOM	10	PWR	VCOM buffer output
VCOMIN	11	I	Positive input terminal of the VCOM buffer. When the VCOM buffer is not used, this terminal can be connected to GND to reduce the overall quiescent current of the IC.
VIN	4	PWR	Input voltage pin of the device
GND	19	GND	Connect this pin to common ground plane under the thermal power pad.
PGND	7, 8	GND	Power ground
Thermal pad	—	GND	The exposed PowerPAD should be connected to the power ground (PGND).

## 6 Specifications

### 6.1 Absolute Maximum Ratings

over operating free-air temperature range (unless otherwise noted)<sup>(1)</sup>

		MIN	MAX	UNIT
Voltage range <sup>(2)</sup>	VIN	−0.3	6	V
	SUP	−0.3	15.5	
	EN, MODE, ENR	−0.3	V <sub>I</sub> + 0.3	
Voltage	VCOMIN		14	V
Voltage <sup>(2)</sup>	SW		20	V
Continuous power dissipation		See <a href="#">Thermal Information</a>		
Operating junction temperature range		−40	150	°C
Lead temperature (soldering, 10 seconds)			260	°C
Storage temperature, T <sub>stg</sub>		−65	150	°C

(1) Stresses beyond those listed under *Absolute Maximum Ratings* may cause permanent damage to the device. These are stress ratings only, which do not imply functional operation of the device at these or any other conditions beyond those indicated under [Recommended Operating Conditions](#). Exposure to absolute-maximum-rated conditions for extended periods may affect device reliability.

(2) Voltage values are with respect to network ground terminal.

### 6.2 ESD Ratings

		VALUE	UNIT
V <sub>(ESD)</sub>	Electrostatic discharge	Human-body model (HBM), per AEC Q100-002 <sup>(1)</sup>	±2000
		Charged-device model (CDM), per AEC Q100-011	±1000
		Machine model (MM)	±100

(1) AEC Q100-002 indicates that HBM stressing shall be in accordance with the ANSI/ESDA/JEDEC JS-001 specification.

### 6.3 Recommended Operating Conditions

		MIN	NOM	MAX	UNIT
V <sub>I</sub>	Input voltage	2.7		5.8	V
L	Inductor <sup>(1)</sup>		4.7		μH
T <sub>A</sub>	Operating free-air temperature	−40		125	°C

(1) See [Inductor Selection](#) for further information.

## 6.4 Thermal Information

THERMAL METRIC <sup>(1)</sup>		TPS65100-Q1	UNIT
		PWP (TSSOP)	
		24 PINS	
R <sub>θJA</sub>	Junction-to-ambient thermal resistance	37.2	°C/W
R <sub>θJC(top)</sub>	Junction-to-case (top) thermal resistance	19.5	°C/W
R <sub>θJB</sub>	Junction-to-board thermal resistance	16.7	°C/W
ψ <sub>JT</sub>	Junction-to-top characterization parameter	0.4	°C/W
ψ <sub>JB</sub>	Junction-to-board characterization parameter	16.6	°C/W
R <sub>θJC(bot)</sub>	Junction-to-case (bottom) thermal resistance	2.1	°C/W

(1) For more information about traditional and new thermal metrics, see the *Semiconductor and IC Package Thermal Metrics* application report, [SPRA953](#).

## 6.5 Electrical Characteristics

V<sub>I</sub> = 3.3 V, EN = VIN, V<sub>O1</sub> = 10 V, T<sub>J</sub> = –40°C to 125°C, typical values are at T<sub>A</sub> = 25°C (unless otherwise noted)

PARAMETER	TEST CONDITIONS	MIN	TYP	MAX	UNIT	
<b>SUPPLY CURRENT</b>						
I <sub>Q</sub>	Quiescent current into VIN	ENR = VCOMIN = GND, V <sub>O3</sub> = 2 × V <sub>O1</sub> , Boost converter not switching	0.7	0.9	mA	
I <sub>QCharge</sub>	Charge pump quiescent current into SUP	V <sub>O1</sub> = SUP = 10 V, V <sub>O3</sub> = 2 × V <sub>O1</sub>	1.7	2.7	mA	
		V <sub>O1</sub> = SUP = 10 V, V <sub>O3</sub> = 3 × V <sub>O1</sub>	3.9	6		
I <sub>QVCOM</sub>	VCOM quiescent current into SUP	ENR = GND, V <sub>O1</sub> = SUP = 10 V	750	1300	μA	
I <sub>QEN</sub>	LDO controller quiescent current into VIN	ENR = VIN, EN = GND	300	800	μA	
I <sub>SD</sub>	Shutdown current into VIN	EN = ENR = GND	1	10	μA	
V <sub>UVLO</sub>	Undervoltage lockout threshold	VIN falling	2.2	2.4	V	
	Thermal shutdown	Temperature rising	160		°C	
<b>LOGIC SIGNALS EN, ENR</b>						
V <sub>IH</sub>	High-level input voltage	1.5			V	
V <sub>IL</sub>	Low-level input voltage			0.4	V	
I <sub>Leak</sub>	Input leakage current	EN = GND or VIN	0.01	0.1	μA	
<b>MAIN BOOST CONVERTER</b>						
V <sub>O1</sub>	Output voltage range	5		15	V	
V <sub>O1</sub> - V <sub>I</sub>	Minimum input to output voltage difference	1			V	
V <sub>REF</sub>	Reference voltage	1.198	1.213	1.230	V	
V <sub>FB</sub>	Feedback regulation voltage	1.126	1.146	1.161	V	
I <sub>FB</sub>	Feedback input bias current		10	100	nA	
r <sub>DS(ON)</sub>	N-MOSFET on-resistance (Q1)	V <sub>O1</sub> = 10 V, I <sub>SW</sub> = 500 mA	195	325	mΩ	
		V <sub>O1</sub> = 5 V, I <sub>SW</sub> = 500 mA	285	455		
I <sub>LIM</sub>	N-MOSFET switch current limit (Q1)	1.6	2.3	2.7	A	
r <sub>DS(ON)</sub>	P-MOSFET on-resistance (Q2)	V <sub>O1</sub> = 10 V, I <sub>SW</sub> = 100 mA	9	15	Ω	
		V <sub>O1</sub> = 5 V, I <sub>SW</sub> = 100 mA	14	22		
I <sub>MAX</sub>	Maximum P-MOSFET peak switch current			1	A	
I <sub>Leak</sub>	Switch leakage current	V <sub>SW</sub> = 15 V	1	10	μA	
f <sub>SW</sub>	Oscillator frequency	0°C ≤ T <sub>J</sub> ≤ 125°C	1.195	1.6	2.1	MHz
		–40°C ≤ T <sub>J</sub> ≤ 125°C	1.091	1.6	2.1	

**Electrical Characteristics (continued)**
 $V_I = 3.3\text{ V}$ ,  $EN = VIN$ ,  $V_{O1} = 10\text{ V}$ ,  $T_J = -40^\circ\text{C}$  to  $125^\circ\text{C}$ , typical values are at  $T_A = 25^\circ\text{C}$  (unless otherwise noted)

PARAMETER		TEST CONDITIONS	MIN	TYP	MAX	UNIT
Line regulation		$2.7\text{ V} \leq V_I \leq 5.7\text{ V}$ , $I_{load} = 100\text{ mA}$		0.012		%/V
Load regulation		$0\text{ mA} \leq I_O \leq 300\text{ mA}$		0.2		%/A
<b>NEGATIVE CHARGE PUMP V<sub>O2</sub></b>						
V <sub>O2</sub>	Output voltage range		-2			V
V <sub>REF</sub>	Reference voltage		1.198	1.213	1.226	V
V <sub>FB</sub>	Feedback regulation voltage		-36	0	36	mV
I <sub>FB</sub>	Feedback input bias current			10	100	nA
r <sub>DS(ON)</sub>	Q8 P-channel switch r <sub>DS(ON)</sub>	I <sub>O</sub> = 20 mA		4.3	8	Ω
	Q9 N-channel switch r <sub>DS(ON)</sub>			2.9	4.4	
I <sub>O</sub>	Maximum output current		20			mA
Line regulation		$7\text{ V} \leq V_{O1} \leq 15\text{ V}$ , $I_{load} = 10\text{ mA}$ , $V_{O2} = -5\text{ V}$		0.09		%/V
Load regulation		$1\text{ mA} \leq I_O \leq 20\text{ mA}$ , $V_{O2} = -5\text{ V}$		0.126		%/mA
<b>POSITIVE CHARGE PUMP V<sub>O3</sub></b>						
V <sub>O3</sub>	Output voltage range				30	V
V <sub>REF</sub>	Reference voltage		1.198	1.213	1.226	V
V <sub>FB</sub>	Feedback regulation voltage		1.180	1.214	1.245	V
I <sub>FB</sub>	Feedback input bias current			10	100	nA
r <sub>DS(ON)</sub>	Q3 P-channel switch r <sub>DS(ON)</sub>	I <sub>O</sub> = 20 mA		9.9	15.5	Ω
	Q4 N-channel switch r <sub>DS(ON)</sub>			1.1	1.8	
	Q5 P-channel switch r <sub>DS(ON)</sub>			4.6	8.5	
	Q6 N-channel switch r <sub>DS(ON)</sub>			1.2	2.2	
V <sub>D</sub>	D1–D4 Schottky diode forward voltage	I <sub>D1–D4</sub> = 40 mA		610	800	mV
I <sub>O</sub>	Maximum output current		20			mA
Line regulation		$10\text{ V} \leq V_{O1} \leq 15\text{ V}$ , $I_{load} = 10\text{ mA}$ , $V_{O3} = 27\text{ V}$		0.56		%/V
Load regulation		$1\text{ mA} \leq I_O \leq 20\text{ mA}$ , $V_{O3} = 27\text{ V}$		0.05		%/mA
<b>LINEAR REGULATOR CONTROLLER V<sub>O4</sub></b>						
V <sub>O4</sub>	Output voltage	$4.5\text{ V} \leq V_I \leq 5.5\text{ V}$ , $10\text{ mA} \leq I_O \leq 500\text{ mA}$	3.2	3.3	3.4	V
I <sub>BASE</sub>	Maximum base drive current	$V_I - V_{O4} - V_{BE} \geq 0.5\text{ V}^{(1)}$	13.5	19		mA
		$V_I - V_{O4} - V_{BE} \geq 0.75\text{ V}^{(1)}$	20	27		
Line regulation		$4.75\text{ V} \leq V_I \leq 5.5\text{ V}$ , $I_{load} = 500\text{ mA}$		0.186		%/V
Load regulation		$1\text{ mA} \leq I_O \leq 500\text{ mA}$ , $V_I = 5\text{ V}$		0.064		%/A
Start up current		$V_{O4} \leq 0.8\text{ V}$	11	20	25	mA
<b>VCOM BUFFER</b>						
V <sub>CM</sub>	Common mode input range		2.25		(V <sub>O1</sub> ) - 2	V
V <sub>OS</sub>	Input offset voltage	I <sub>O</sub> = 0 mA	-25		25	mV
	DC Load regulation	I <sub>O</sub> = ±25 mA	-30		37	mV
		I <sub>O</sub> = ±50 mA	-45		55	
		I <sub>O</sub> = ±100 mA	-72		85	
		I <sub>O</sub> = ±150 mA	-97		110	
I <sub>B</sub>	VCOMIN Input bias current		-300	-30	300	nA
I <sub>Peak</sub>	Peak output current	V <sub>O1</sub> = 15 V	1.2			A
		V <sub>O1</sub> = 10 V	0.65			A
		V <sub>O1</sub> = 5 V	0.15			A

(1) With  $V_I$  = supply voltage of the TPS65100-Q1,  $V_{O4}$  = output voltage of the regulator,  $V_{BE}$  = basis emitter voltage of external transistor

### Electrical Characteristics (continued)

$V_I = 3.3\text{ V}$ ,  $EN = VIN$ ,  $V_{O1} = 10\text{ V}$ ,  $T_J = -40^\circ\text{C}$  to  $125^\circ\text{C}$ , typical values are at  $T_A = 25^\circ\text{C}$  (unless otherwise noted)

PARAMETER		TEST CONDITIONS	MIN	TYP	MAX	UNIT
<b>FAULT PROTECTION THRESHOLDS</b>						
$V_{(th, Vo1)}$	Shutdown threshold	$V_{O1}$ Rising	-12	-8.75% $V_{O1}$	-6	V
$V_{(th, Vo2)}$		$V_{O2}$ Rising	-13	-9% $V_{O2}$	-5	V
$V_{(th, Vo3)}$		$V_{O3}$ Rising	-11	-8% $V_{O3}$	-5	V

### 6.6 Typical Characteristics

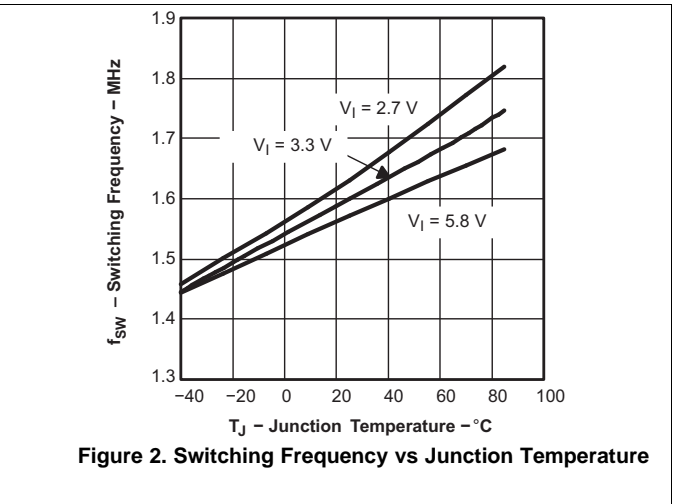
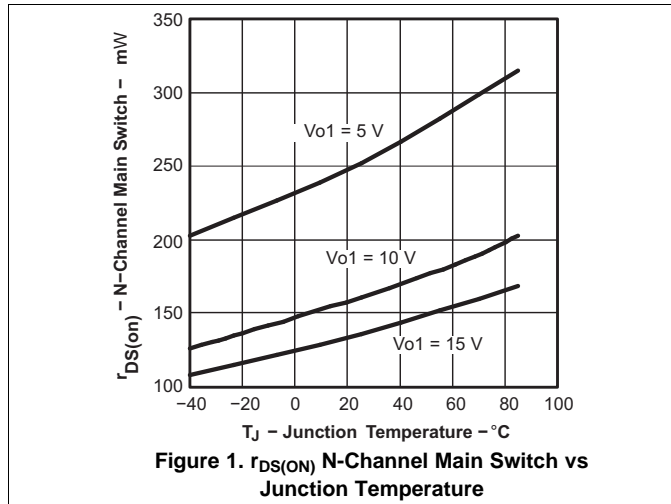

## 7 Detailed Description

### 7.1 Overview

The TPS65100-Q1 is a complete bias supply for LCD displays. It contains a main boost converter to supply the source driver. It operates with a fixed switching frequency of 1.6 MHz to allow for small external components. The boost converter output voltage  $V_{O1}$  is also the input voltage, connected via the pin SUP, for the positive and negative charge pumps and the bias supply for the VCOM buffer.

The linear regulator controller is independent from this system with its own enable pin. This design allows the linear regulator controller to continue to operate while the other supply rails are disabled or in shutdown due to a fault condition on one of their outputs.

## 7.2 Functional Block Diagram

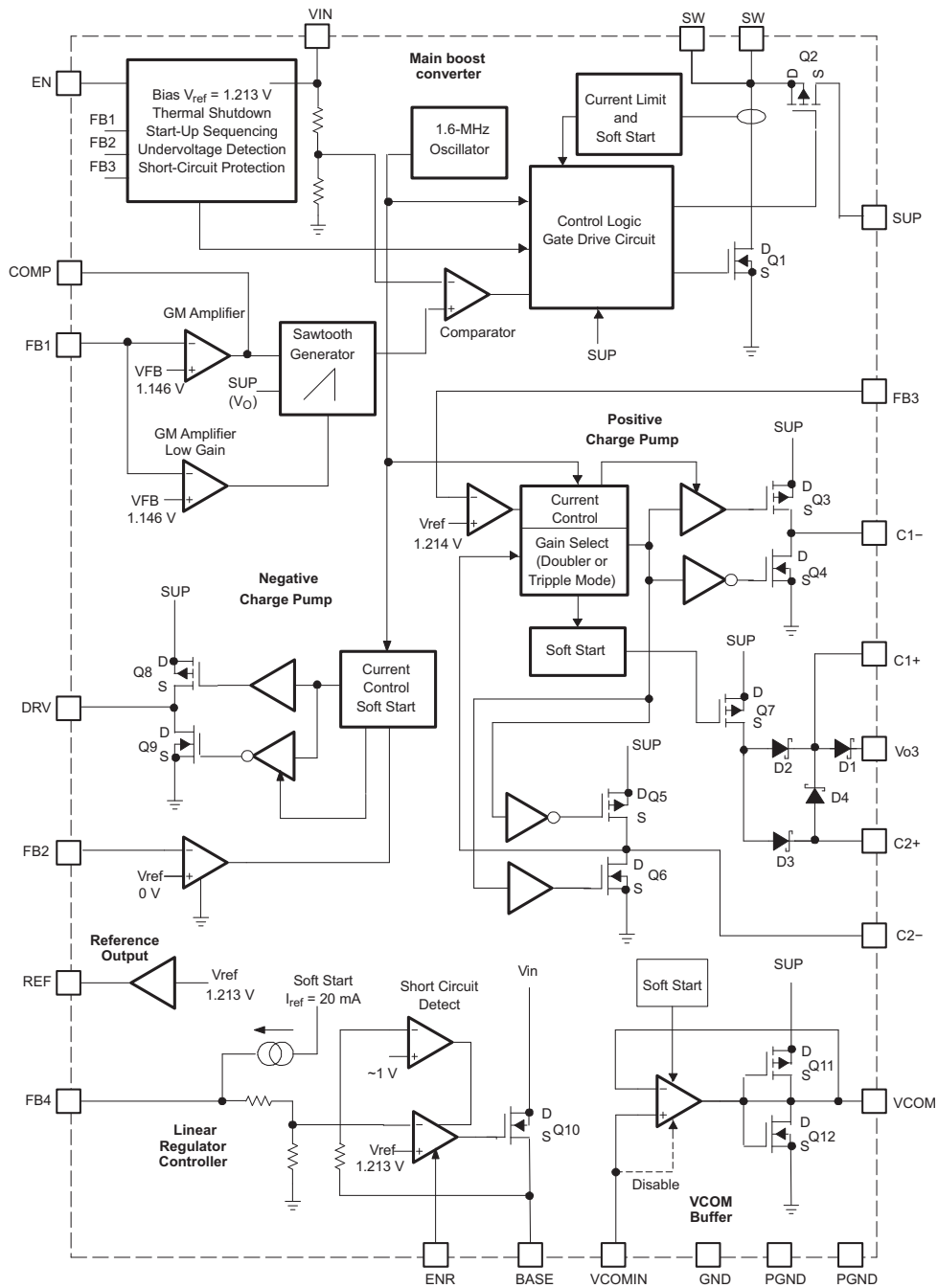

## 7.3 Feature Description

### 7.3.1 Main Boost Converter

The main boost converter operates with PWM and a fixed switching frequency of 1.6 MHz. The converter uses a unique fast-response voltage-mode controller scheme with input voltage feedforward. This achieves excellent line and load regulation (0.2%/A load regulation typical) and allows the use of small external components. For higher flexibility to the selection of external component values the device uses external loop compensation. The TPS65100-Q1 device maintains continuous conduction even at light load currents because of an internal PMOS

## Feature Description (continued)

in parallel connected between SW and SUP pin. When the inductor current is positive, the external schottky diode with the lower forward voltage conducts the current. This causes the converter to operate with a fixed frequency in continuous conduction mode over the entire load current range. This avoids the ringing on the switch pin as seen with a standard nonsynchronous boost converter and allows a simpler compensation for the boost converter.

### 7.3.2 VCOM Buffer

VCOMIN is the input of the VCOM buffer. If VCOM is not required connect VCOMIN pin to Ground and thereby reduce the overall quiescent current.

The VCOM buffer features soft start to avoid a large voltage drop at  $V_{O1}$ . During operation the VCOMIN pin cannot be pulled dynamically to ground.

### 7.3.3 Positive Charge Pump

The TPS65100-Q1 device has a fully regulated integrated positive charge pump generating  $V_{O3}$ . The input voltage for the charge pump is applied to the SUP pin that is equal to the output of the main boost converter  $V_{O1}$ . The charge pump is capable of supplying a minimum load current of 20 mA. Depending on the voltage difference between  $V_{O1}$  and  $V_{O3}$  higher load currents are possible (see [Figure 17](#) and [Figure 18](#)).

### 7.3.4 Negative Charge Pump

The TPS65100-Q1 device has a regulated negative charge pump using two external Schottky diodes. The input voltage for the charge pump is applied to the SUP pin that is connected to the output of the main boost converter  $V_{O1}$ . The charge pump inverts the main boost converter output voltage and is capable of supplying a minimum load current of 20 mA. Depending on the voltage difference between  $V_{O1}$  and  $V_{O2}$ , higher load currents are possible (see [Figure 16](#)).

### 7.3.5 Linear Regulator Controller

The TPS65100-Q1 device includes a linear regulator controller to generate a 3.3-V rail which is useful when the system is powered from a 5-V supply. The regulator is independent from the other voltage rails of the device and has its own enable (ENR). Since most of the systems require this voltage rail to come up first it is recommended to use a R-C delay on EN. This delays the start-up of the main boost converter which will reduce the inrush current as well.

## 7.4 Device Functional Modes

### 7.4.1 Enable and Power-ON Sequencing (EN, ENR)

The device has two enable pins. These pins should be terminated and should not be left floating to prevent unpredictable operation. Pulling the enable pin (EN) high enables the device and starts the power-on sequencing with the main boost converter  $V_{O1}$  coming up first, then the negative and positive charge pump and the VCOM buffer. If the VCOMIN pin is held low, the VCOM buffer remains disabled. The linear regulator has an independent enable pin (ENR). Pulling this pin low disables the regulator, and pulling this pin high enables this regulator.

If the enable pin EN is pulled high, the device starts its power-ON sequencing. The main boost converter starts up first with its soft start. If the output voltage has reached 91.25% of its output voltage, the negative charge pump comes up next. The negative charge pump starts with a soft start and when the output voltage has reached 91% of the nominal value, the positive charge pump comes up with a soft start. The VCOM buffer is enabled as soon as the positive charge pump has reached its nominal value and VCOMIN is greater than typically 1 V. Pulling the enable pin low shuts down the device. Depending on load current and output capacitance, each of the outputs goes down.

### 7.4.2 Soft Start

The main boost converter as well as the charge pumps, linear regulator, and VCOM buffer have an internal soft start. This avoids heavy voltage drops at the input voltage rail or at the output of the main boost converter  $V_{O1}$  during start-up caused by high inrush currents (see [Figure 14](#) and [Figure 15](#)). During soft start of the main boost converter  $V_{O1}$ , the internal current limit threshold is increased in three steps. The device starts with the first step, where the current limit is set to 2/5 of the typical current limit (2/5 of 2.3 A) for 1024 clock cycles, then increased to 3/5 of the current limit for 1024 clock cycles, and finally raised to the full current limit.

### 7.4.3 Fault Protection

All the outputs of the TPS65100-Q1 device have short-circuit detection that can force the device into shutdown. The main boost converter has overvoltage and undervoltage protection. If the output voltage  $V_{O1}$  rises above the overvoltage protection threshold of 105% of  $V_{O1}$  (typical), the device stops switching but remains operational. When the output voltage falls below this threshold again, the converter continues operation. When the output voltage falls below power good threshold of 91.25% of  $V_{O1}$  (typical), in case of a short-circuit condition, then the TPS65100-Q1 device goes into shutdown. Because there is a direct pass from the input to the output through the diode, the short-circuit condition remains. If this condition needs to be avoided, a fuse at the input or an output disconnect using a single transistor and resistor is required. The negative and positive charge pumps have an undervoltage lockout to protect the LCD panel from possible latchup conditions in the event of a short-circuit condition or faulty operation. When the negative output voltage is less than 90.5% (typical) of its output voltage (closer to ground), the device enters shutdown. When the positive charge pump output voltage  $V_{O3}$  is below 92% (typical) of its output voltage, the device goes into shutdown as well. See the electrical characteristics table under fault protection thresholds. The device can be enabled again by toggling the enable pin (EN) below 0.4 V or by cycling the input voltage below the UVLO of 1.7 V. The linear regulator reduces the output current to typical 20 mA under a short-circuit condition when the output voltage is < 1 V (typical). See the functional block diagram. The linear regulator does not go into shutdown under a short-circuit condition.

### 7.4.4 Thermal Shutdown

A thermal shutdown is implemented to prevent damage due to excessive heat and power dissipation. Typically, the thermal shutdown threshold is 160°C. If this temperature is reached, the device goes into shutdown. The device can be enabled by toggling the enable pin to low and back to high or by cycling the input voltage to GND and back to  $V_I$  again.

## 8 Application and Implementation

### NOTE

Information in the following applications sections is not part of the TI component specification, and TI does not warrant its accuracy or completeness. TI's customers are responsible for determining suitability of components for their purposes. Customers should validate and test their design implementation to confirm system functionality.

### 8.1 Application Information

Figure 3 shows a general overview of the device and connections used in an application. Ranges are shown for several parameters to demonstrate the flexibility available to the application designer.

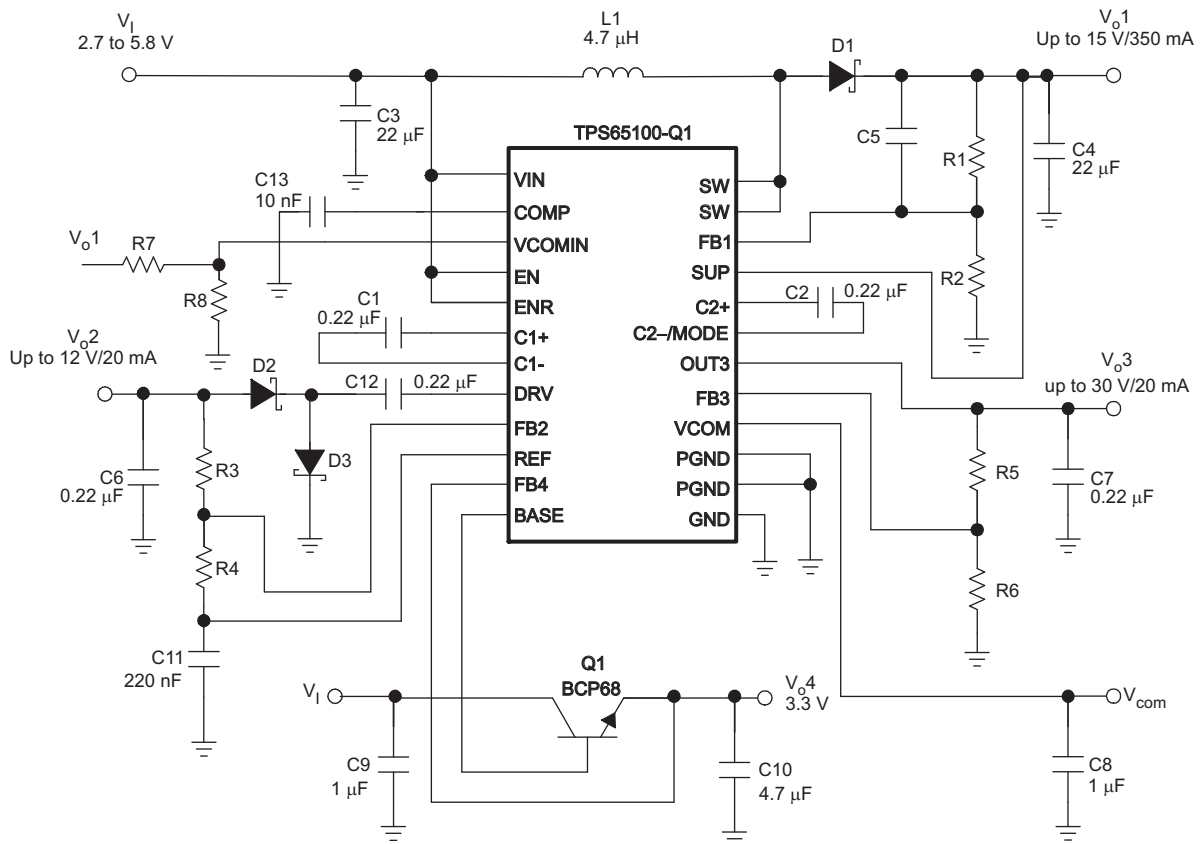

Figure 3. Simplified Schematic

## 8.2 Typical Applications

### 8.2.1 Supply for a Typical Approximately 7-inch Display

A typical application requirement is to boost a 3.3-V or 5-V input to a 10-V, 13.5-V, or 15-V output. The [Detailed Design Procedure](#) section explains the step-by-step development.

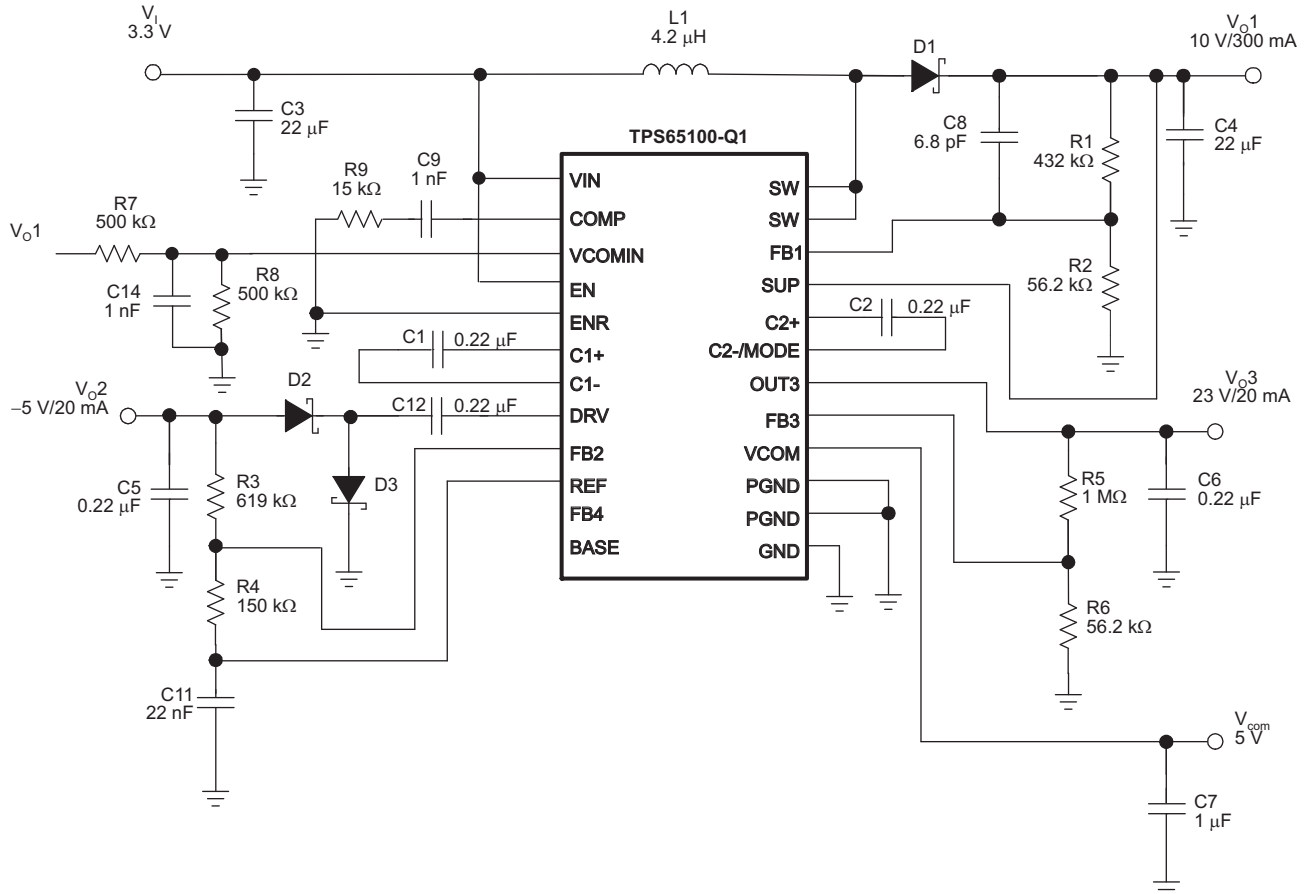

Figure 4. Supply for a 7-inch Display Diagram

#### 8.2.1.1 Design Requirements

For this design example, use the parameters listed in [Table 1](#) as the input parameters.

Table 1. Design Parameters

DESIGN PARAMETER	EXAMPLE VALUE
$V_I$	3.3 V
$V_{O1}$	10 V
$V_{O2}$	-5 V
$V_{O3}$	23 V
Switch voltage drop, $V_{SW}$	0.5 V
Schottky diode forward voltage, $V_D$	0.8 V
$V_{COM}$	5 V

### 8.2.1.2 Detailed Design Procedure

#### 8.2.1.2.1 Boost Converter Design Procedure

The first step in the design procedure is to calculate the maximum possible output current of the main boost converter under certain input and output voltage conditions. This example is for a 3.3-V to 10-V conversion:

1. Duty cycle

$$D = \frac{V_O + V_D - V_I}{V_O + V_D - V_{SW}} = \frac{10 \text{ V} + 0.8 \text{ V} - 3.3 \text{ V}}{10 \text{ V} + 0.8 \text{ V} - 0.5 \text{ V}} = 0.73 \quad (1)$$

2. Average inductor current

$$I_L = \frac{I_O}{1-D} = \frac{300 \text{ mA}}{1-0.73} = 1.11 \text{ A} \quad (2)$$

3. Inductor peak-to-peak ripple current

$$\Delta I_L = \frac{(V_I - V_{SW}) \times D}{f_S \times L} = \frac{(3.3 \text{ V} - 0.5 \text{ V}) \times 0.73}{1.6 \text{ MHz} \times 4.2 \text{ } \mu\text{H}} = 304 \text{ mA} \quad (3)$$

4. Peak switch current

$$I_{swpeak} = I_L + \frac{\Delta I_L}{2} = 1.11 \text{ A} + \frac{304 \text{ mA}}{2} = 1.26 \text{ A} \quad (4)$$

The integrated switch, the inductor, and the external Schottky diode must be able to handle the peak switch current. The calculated peak switch current must be equal to or lower than the minimum N-MOSFET switch current limit specified in [Electrical Characteristics](#). If the peak switch current is higher, the converter cannot support the required load current. This calculation must be done for the minimum input voltage, where the peak switch current is highest. The calculation includes conduction losses like switch  $r_{DS(ON)}$  (0.5 V) and diode forward drop voltage losses (0.8 V). Additional switching losses and inductor core and winding losses require a slightly higher peak switch current in the actual application. This calculation still allows for good design and component selection.

##### 8.2.1.2.1.1 Inductor Selection

Several inductors work with the TPS65100-Q1 device and, particularly with the external compensation, performance can be adjusted to application requirements. The main parameter for inductor selection is the saturation current of the inductor, which should be higher than the peak switch current as previously calculated, with additional margin to allow for heavy load transients and extreme start-up conditions. Another method is to choose an inductor with a saturation current at least as high as the minimum switch current limit of 1.6 A. The different switch-current limits allow selection of a physically smaller inductor when less output current is required. Another important parameter is inductor DC resistance. Usually, the lower the DC resistance, the higher the efficiency. However, inductor DC resistance is not the only parameter determining the efficiency. Especially for a boost converter where the inductor is the energy storage element, the type and material of the inductor influences the efficiency as well. At the high switching frequency of 1.6 MHz, inductor core losses, proximity effects, and skin effects are more important. Usually, an inductor with a larger form factor yields higher efficiency. The efficiency difference between different inductors can vary between 2% to 10%. TI recommends inductor values between 3.3  $\mu\text{H}$  and 6.8  $\mu\text{H}$ .

### 8.2.1.2.1.2 Output Capacitor Selection

For the best output voltage filtering, TI recommends a low ESR output capacitor. Ceramic capacitors have a low ESR value, but depending on the application, tantalum capacitors can be used as well. A 22- $\mu$ F ceramic output capacitor works for most of the applications. Higher capacitor values can be used to improve the load transient regulation. The output voltage ripple can be calculated as:

$$\Delta V_O = \frac{I_O}{C_O} \times \left( \frac{1}{f_S} - \frac{I_P \times L}{V_O + V_D - V_I} \right) + I_P \times \text{ESR}$$

where

- $I_P$  = Peak switch current as calculated in the previous section with  $I_{\text{SW(peak)}}$
- $L$  = Selected inductor value
- $I_O$  = Normal load current
- $f_S$  = Switching frequency
- $V_D$  = Rectifier diode forward voltage (typical 0.3 V)
- $C_O$  = Selected output capacitor
- ESR = Output capacitor ESR value

(5)

### 8.2.1.2.1.3 Input Capacitor Selection

For good input voltage filtering, TI recommends low ESR ceramic capacitors. A 22- $\mu$ F ceramic input capacitor is sufficient for most of the applications. For better input voltage filtering, this value can be increased.

### 8.2.1.2.1.4 Rectifier Diode Selection

To achieve high efficiency, a Schottky diode should be used. The voltage rating must be higher than the maximum output voltage of the converter. The average forward current must be equal to the average inductor current of the converter. The main parameter influencing the efficiency of the converter is the forward voltage and the reverse leakage current of the diode; both must be as low as possible.

### 8.2.1.2.1.5 Converter Loop Design and Stability

The TPS65100-Q1 device converter loop can be externally compensated and allows access to the internal transconductance error amplifier output at the COMP pin. A small feedforward capacitor across the upper feedback resistor divider speeds up the circuit as well. To test the converter stability and load transient performance of the converter, a load step from 50 mA to 250 mA is applied, and the output voltage of the converter is monitored. Applying load steps to the converter output is a good tool to judge the stability of such a boost converter.

### 8.2.1.2.1.6 Design Procedure Quick Steps

1. Select the feedback resistor divider to set the output voltage.
2. Select the feedforward capacitor to place a zero at 50 kHz.
3. Select the compensation capacitor on pin COMP. The smaller the value, the higher the low frequency gain.
4. Use a 50-k $\Omega$  potentiometer in series to  $C_C$  and monitor  $V_{O1}$  during load transients. Fine tune the load transient by adjusting the potentiometer. Select a resistor value that comes closest to the potentiometer resistor value. This needs to be done at the highest  $V_I$  and highest load current since the stability is most critical at these conditions.

**8.2.1.2.1.7 Setting the Output Voltage and Selecting the Feedforward Capacitor**

The output voltage is set by the external resistor divider and is calculated as:

$$V_O = 1.146 \text{ V} \times \left(1 + \frac{R1}{R2}\right) \tag{6}$$

Across the upper resistor a bypass capacitor is required to speed up the circuit during load transients as shown in Figure 5.

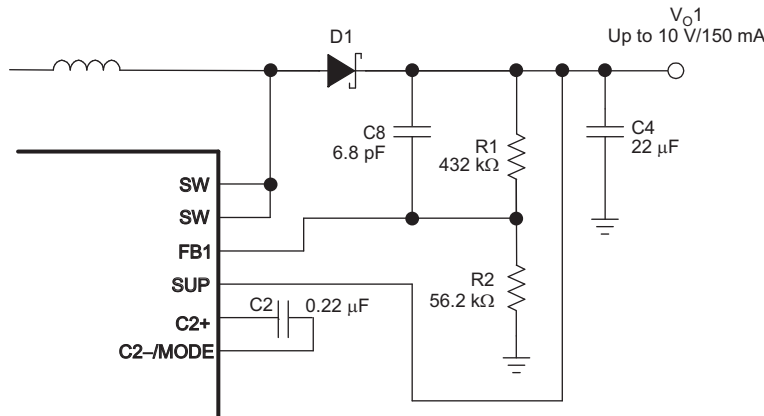
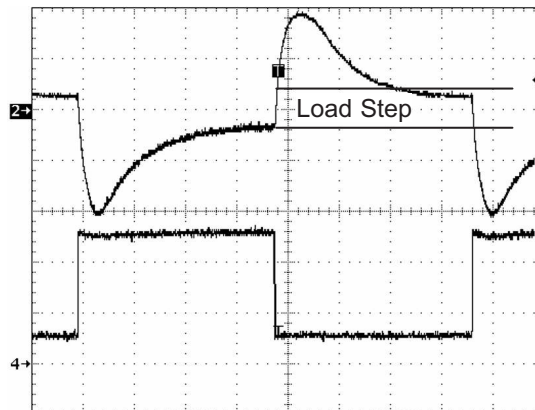

**Figure 5. Feed-forward Capacitor**

Together with R1 the bypass capacitor C8 sets a zero in the control loop at approximately 50 kHz:

$$f_z = \frac{1}{2 \times \pi \times C8 \times R1} \tag{7}$$

A value closest to the calculated value should be used. Larger feedforward capacitor values reduce the load regulation of the converter and cause load steps as shown in Figure 6.



**Figure 6. Load Step Caused By A Too Large Feed-forward Capacitor Value**

For more information on how to calculate a Boost Converter's Output Stage refer to *Basic Calculation of a Boost Converter's Power Stage*.

**8.2.1.2.2 Negative Charge Pump**

The negative charge pump provides a regulated output voltage by inverting the main output voltage V\_O1. The negative charge pump output voltage within its output voltage range is set with external feedback resistors.

The maximum load current of the negative charge pump depends on the voltage drop across the external Schottky diodes and the internal on resistance of the charge pump MOSFETS. When the voltage drop across these components is larger than the voltage difference from  $V_{O1}$  to  $V_{O2}$ , the charge pump is in dropout, providing the maximum possible output current. Therefore, the higher the voltage difference between  $V_{O1}$  and  $V_{O2}$ , the higher the possible load current. See [Figure 16](#) for the possible output current versus boost converter voltage  $V_{O1}$ .

Estimating the maximum output voltage range of a single negative charge-pump stage:

$$V_{O(\min)} = -(V_{O1} - 2 \times V_D - I_O \times (2 \times r_{DS(ON)Q8} + 2 \times r_{DS(ON)Q9})) \quad (8)$$

Setting the output voltage:

$$V_O = -V_{REF} \times \frac{R3}{R4} = -1.213 \text{ V} \times \frac{R3}{R4} \quad (9)$$

$$R3 = R4 \times \frac{|V_O|}{V_{REF}} = R4 \times \frac{|V_O|}{1.213 \text{ V}} \quad (10)$$

The lower feedback resistor value  $R4$  should be in a range between 40 k $\Omega$  to 120 k $\Omega$  or the overall feedback resistance should be within 500 k $\Omega$  to 1 M $\Omega$ . Smaller values load the reference too heavily and larger values may cause stability problems. For this design, 619 k $\Omega$  and 150 k $\Omega$  were chosen, delivering  $-5 \text{ V}$ . The negative charge pump requires two external-Schottky diodes. The peak current rating of the Schottky diode has to be twice the load current of the output. For a 20-mA output current, the dual Schottky diode BAT54 or similar is a good choice.

### 8.2.1.2.3 Positive Charge Pump

The positive charge pump can be operated in a voltage doubler mode or a voltage tripler mode.

The output voltage needs to be within the voltage ranges of the configuration, see [Voltage Doubler Mode](#) and [Voltage Tripler Mode](#). The output voltage within its limitation is set by the external resistor divider and is calculated as:

$$V_{OUT} = 1.214 \times \left(1 + \frac{R5}{R6}\right) \quad (11)$$

$$R5 = R6 \times \left(\frac{V_{OUT}}{V_{FB}} - 1\right) = R6 \times \left(\frac{V_{OUT}}{1.214} - 1\right) \quad (12)$$

The maximum load current of the positive charge pump depends on the voltage drop across the internal Schottky diodes, the internal ON-resistance of the charge pump MOSFETS, and the impedance of the flying capacitor. When the voltage drop across these components is larger than the voltage difference  $V_{O1} \times 2$  to  $V_{O3}$  (doubler mode) or  $V_{O1} \times 3$  to  $V_{O3}$  (tripler mode), then the charge pump is in dropout, providing the maximum possible output current. Therefore, the higher the voltage difference between  $V_{O1} \times 2$  (doubler) or  $V_{O1} \times 3$  (tripler) to  $V_{O3}$ , the higher the possible load current. See [Figure 17](#) and [Figure 18](#) for output current versus boost converter voltage,  $V_{O1}$ , and the following calculations.

#### 8.2.1.2.3.1 Voltage Doubler Mode

- Leave C2+ pin open
- Connect C2-/Mode to GND

The following shows first order formulas to calculate the minimum and maximum output voltages of the positive charge pump in doubler mode

- Minimum:  $V_{O3\min} = V_{O1}$
- Maximum:  $V_{O3\max} = 2 \times V_{O1} - (2 \times V_F + 2 \times I_O \times (2 \times r_{DS(ON)Q5} + r_{DS(ON)Q3} + r_{DS(ON)Q4}))$

For detailed information how to estimate the output voltage ranges refer to [How to Estimate the Output Voltage Range of the Charge Pumps in the TPS6510x and TPS6514x](#). [SLVA918](#)

#### 8.2.1.2.3.2 Voltage Tripler Mode

- Connect flying capacitor to C2+ and C2-/MODE

The following shows first order formulas to calculate the minimum and maximum output voltages of the positive charge pump in doubler mode

- Minimum:  $V_{O3min} = 2 \times V_{O1} - (2 \times V_F + 2 \times I_O \times (2 \times r_{DS(on)Q5} + r_{DS(on)Q3} + r_{DS(on)Q4}))$
- Maximum:  $V_{O3max} = 3 \times V_{O1} - (4 \times V_F + 2 \times I_O \times (3 \times r_{DS(on)Q5} + r_{DS(on)Q3} + r_{DS(on)Q4}))$

For detailed information how to estimate the output voltage ranges refer to *How to Estimate the Output Voltage Range of the Charge Pumps in the TPS6510x and TPS6514x* [SLVA918](#).

#### 8.2.1.2.4 VCOM Buffer

The VCOM buffer is typically used to drive the backplane of a TFT panel. The VCOM output voltage is typically set to half of the main output voltage  $V_{O1}$  plus a small shift to implement the specific compensation voltage. The TFT video signal gets coupled through the TFT storage capacitor plus the LCD cell capacitance to the output of the VCOM buffer. Because of these, short current pulses in the positive and negative direction appear at the output of the VCOM buffer. To minimize the output voltage ripple caused by the current pulses, a transconductance amplifier having a current source output and an output capacitor is used. The output capacitor supports the high frequency part of the current pulses drawn from the LCD panel. The VCOM buffer only needs to handle the low frequency portion of the current pulses. A 1- $\mu$ F ceramic output capacitor is sufficient for most of the applications. When using other output capacitor values it is important to keep in mind that the output capacitor is part of the VCOM buffer loop stabilization.

The VCOM buffer has an integrated soft start to avoid voltage drops on  $V_{O1}$  during start-up. The soft start is implemented as such that the VCOMIN is held low until the VCOM buffer is fully biased and the common mode range is reached. Then the positive input is released and the VCOM buffer output slowly comes up. Usually a 1-nF capacitor on VCOMIN to GND is used to filter high frequency noise coupled in from  $V_{O1}$ . The size of this capacitor together with the upper feedback resistor value determines the start-up time. The larger the capacitor from VCOMIN to GND, the slower the soft start.

#### 8.2.1.2.5 Linear Regulator Controller

The TPS65100-Q1 device includes a linear regulator controller to generate a 3.3-V rail when the system is powered from a 5-V supply. Because an external NPN transistor is required, the input voltage of the TPS65100-Q1 device applied to  $V_{IN}$  needs to be higher than the output voltage of the regulator. To provide a minimum base drive current of 13.5 mA, a minimum internal voltage drop of 500 mV from  $V_I$  to  $V_{base}$  is required. This can be translated into a minimum input voltage on  $V_I$  for a certain output voltage as [Equation 13](#) shows:

$$V_{I(min)} = V_{O4} + V_{BE} + 0.5 \text{ V} \quad (13)$$

The current design operating from  $V_I = 3.3 \text{ V}$  cannot support this and the linear regulator is not used. The second example operating from  $V_I = 5 \text{ V}$  has the 3.3-V regulator implemented.

The base drive current together with the  $h_{FE}$  of the external transistor determines the possible output current. External transistors are selected depending on the output current, power dissipation, and PCB space requirements of the application. The device is stable with a 4.7- $\mu$ F ceramic output capacitor. Larger output capacitor values can be used to improve the load transient response when higher load currents are required.

### 8.2.1.3 Application Curves

**Table 2. Table Of Graphs**

		FIGURE
<b>Main Boost Converter</b>		
Efficiency $V_{O1}$	vs Load current	<a href="#">Figure 7</a>
Efficiency $V_{O1}$	vs Load current	<a href="#">Figure 8</a>
Efficiency $V_{O1}$	vs Input voltage	<a href="#">Figure 9</a>
PWM operation, continuous mode		<a href="#">Figure 10</a>
PWM operation at light load		<a href="#">Figure 11</a>
Load transient response, $C_O = 22 \mu\text{F}$		<a href="#">Figure 12</a>
Load transient response, $C_O = 2 \times 22 \mu\text{F}$		<a href="#">Figure 13</a>
Power-up sequencing		<a href="#">Figure 14</a>
Soft start $V_{O1}$		<a href="#">Figure 15</a>

Table 2. Table Of Graphs (continued)

		FIGURE
<b>Negative Charge Pump</b>		
$V_{O2}$ Maximum load current	vs Output voltage $V_{O1}$	Figure 16
<b>Positive Charge Pump</b>		
$V_{O3}$ Maximum load current	vs Output voltage $V_{O1}$ (doubler mode)	Figure 17
$V_{O3}$ Maximum load current	vs Output voltage $V_{O1}$ (tripler mode)	Figure 18

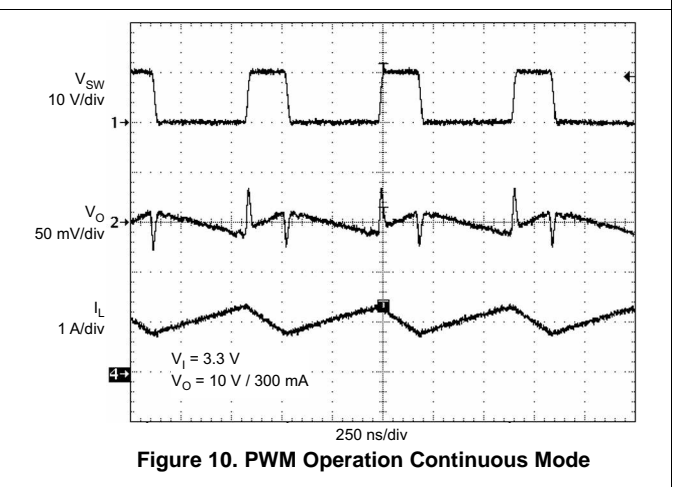
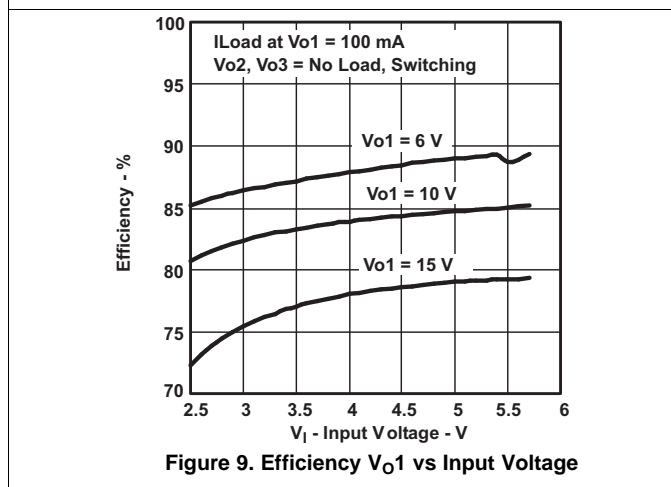
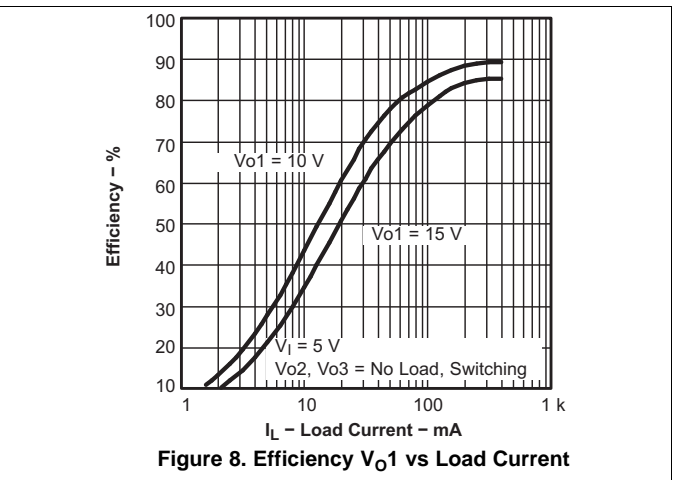
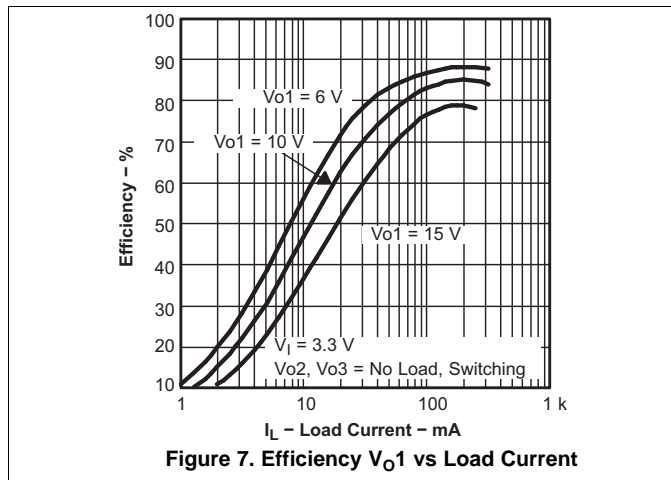

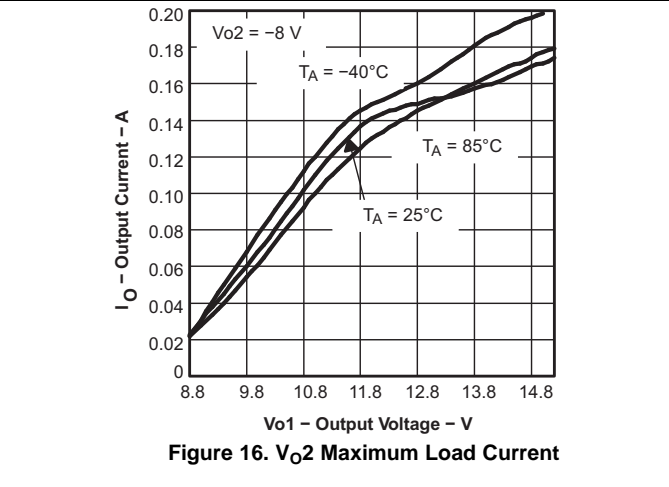
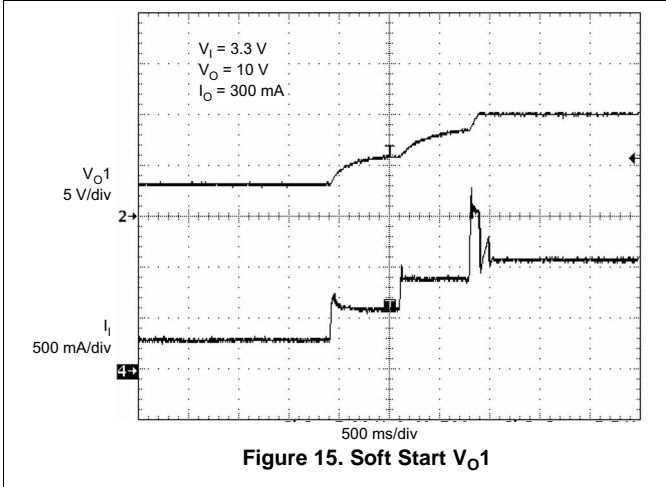
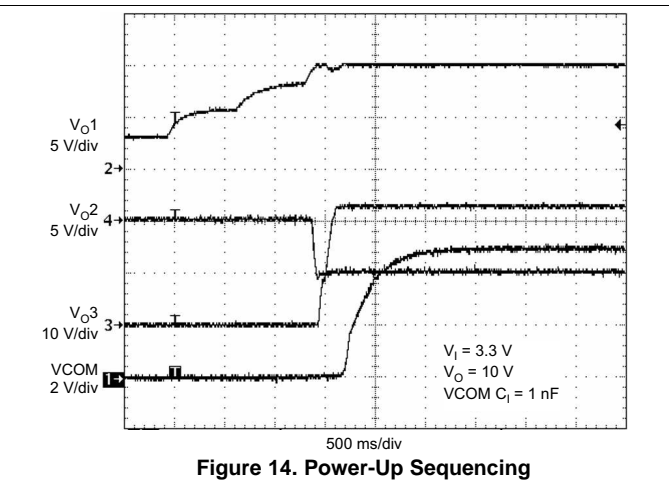
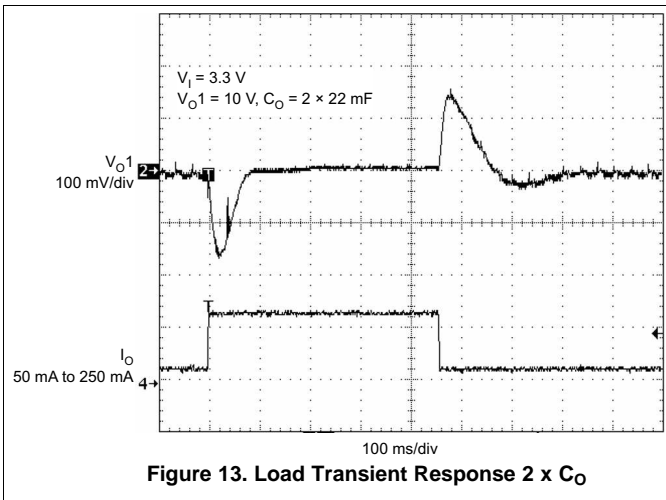
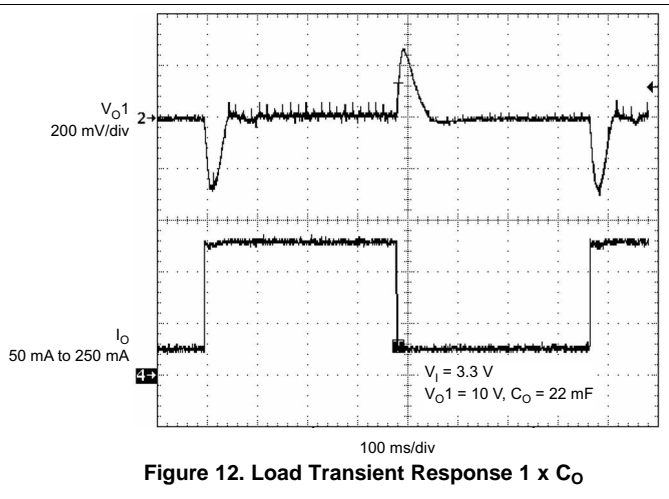
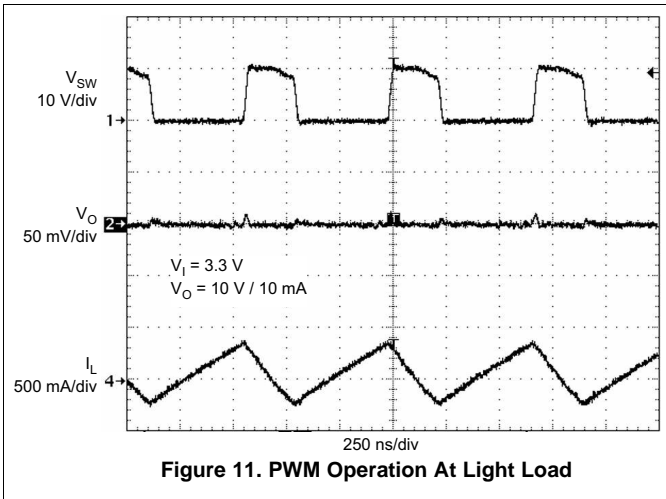

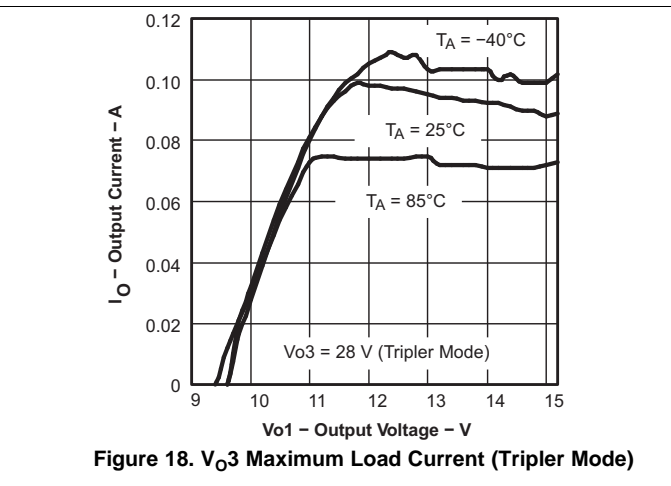
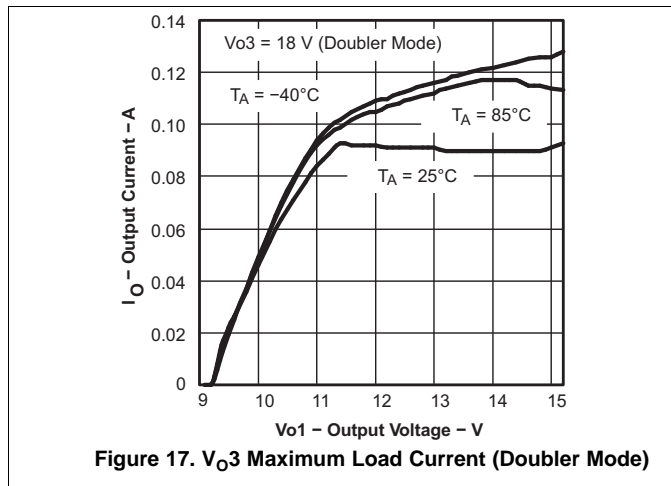

### 8.2.2 Supply for a Typical Approximately 8-inch Display

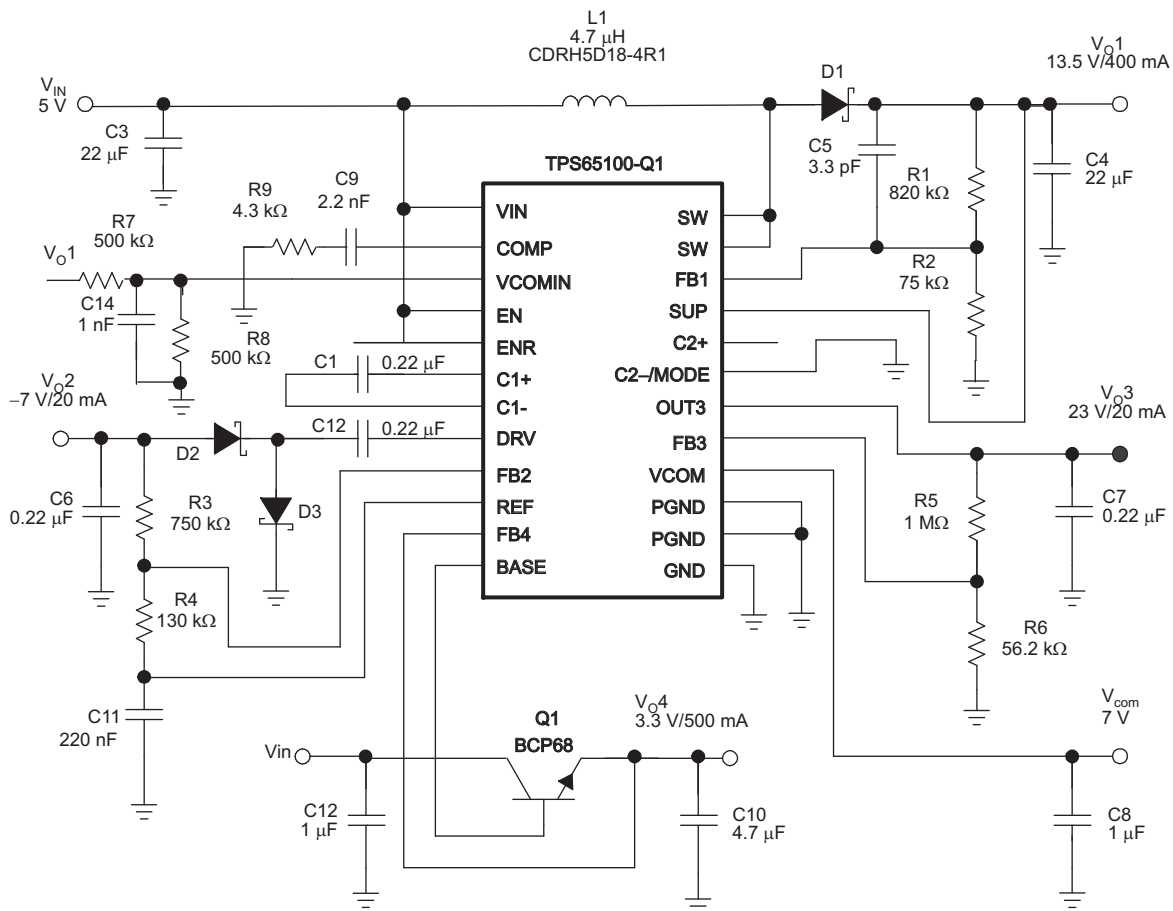

Figure 19. Simplified Schematic for a Typical Approximately 8-inch Display

## 9 Power Supply Recommendations

Apply a supply voltage of 2.7 V to 5.8 V to the VIN pin. In case the 3.3-V linear regulator is supposed to be used, a higher minimum voltage needs to be applied, allowing for some drop-out. As in most cases, the 3.3-V rail needs to come up before the main boost-converter does, an RC-element on the EN pin can delay the ramp of the boost converter.

## 10 Layout

### 10.1 Layout Guidelines

For all switching power supplies, the layout is an important step in the design, especially at high-peak currents and switching frequencies. If the layout is not carefully designed, the regulator might show stability and EMI problems. TI recommends the following PCB layout guidelines for the TPS65100-Q1 device:

- Connect PGND and AGND together on the same ground plane.
- Connect all capacitor grounds and PGND together on a common ground plane.
- Place the input filter capacitor as close as possible to the input pin of the IC.
- Route first the traces carrying high-switching currents with wide and short traces.
- Isolate analog signal paths from power paths.
- If vias are necessary, try to use more than one in parallel to decrease parasitics, especially for power traces.
- Solder the thermal pad to the PCB for good thermal performance

### 10.2 Layout Example

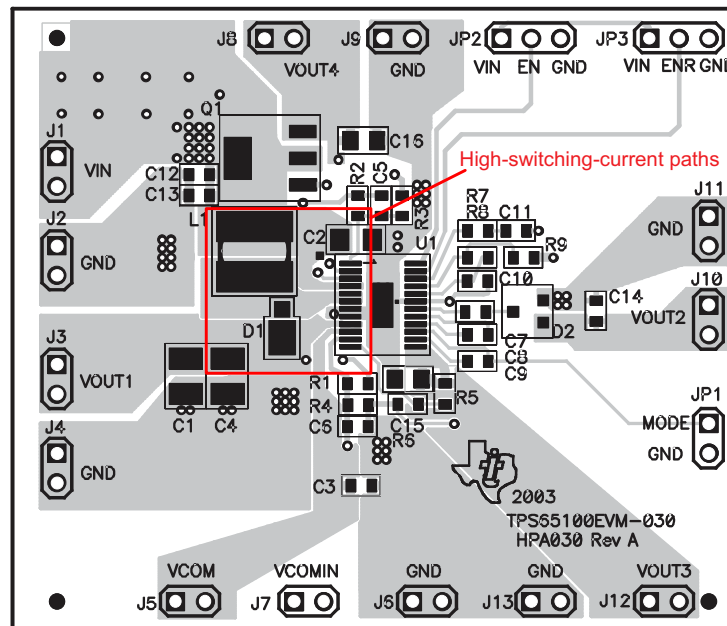

Figure 20. Layout Example

### 10.3 Thermal Considerations

An influential component of thermal performance of a package is board design. To take full advantage of the heat dissipation abilities of the PowerPAD package with exposed thermal die, a board that acts similar to a heat sink and allows the use of an exposed (and solderable) deep downset pad should be used. For further information, see *PowerPAD Thermally Enhanced Package*, [SLMA002](#), and *PowerPAD Made Easy*, [SLMA004](#).

## 11 Device and Documentation Support

### 11.1 Documentation Support

#### 11.1.1 Related Documentation

For related documentation see the following:

- *PowerPAD Thermally Enhanced Package*, [SLMA002](#)
- *PowerPAD Made Easy*, [SLMA004](#)
- *How to Compensate with the TPS6510x and TPS6514x*, [SLVA813](#).
- *Basic Calculation of a Boost Converter's Power Stage*, [SLVA372](#)
- *Customizing Your TPS6510x/TPS6514x*, [SLVA192](#)
- *Power Management Guide 2016* at [www.ti.com](http://www.ti.com)

### 11.2 Community Resources

The following links connect to TI community resources. Linked contents are provided "AS IS" by the respective contributors. They do not constitute TI specifications and do not necessarily reflect TI's views; see TI's [Terms of Use](#).

**TI E2E™ Online Community** *TI's Engineer-to-Engineer (E2E) Community*. Created to foster collaboration among engineers. At [e2e.ti.com](http://e2e.ti.com), you can ask questions, share knowledge, explore ideas and help solve problems with fellow engineers.

**Design Support** *TI's Design Support* Quickly find helpful E2E forums along with design support tools and contact information for technical support.

### 11.3 Trademarks

PowerPAD, E2E are trademarks of Texas Instruments.  
All other trademarks are the property of their respective owners.

### 11.4 Electrostatic Discharge Caution



These devices have limited built-in ESD protection. The leads should be shorted together or the device placed in conductive foam during storage or handling to prevent electrostatic damage to the MOS gates.

### 11.5 Glossary

[SLYZ022](#) — *TI Glossary*.

This glossary lists and explains terms, acronyms, and definitions.

## 12 Mechanical, Packaging, and Orderable Information

The following pages include mechanical, packaging, and orderable information. This information is the most current data available for the designated devices. This data is subject to change without notice and revision of this document. For browser-based versions of this data sheet, refer to the left-hand navigation.

**PACKAGING INFORMATION**

Orderable Device	Status (1)	Package Type	Package Drawing	Pins	Package Qty	Eco Plan (2)	Lead/Ball Finish (6)	MSL Peak Temp (3)	Op Temp (°C)	Device Marking (4/5)	Samples
TPS65100QPWRQ1	ACTIVE	HTSSOP	PWP	24	2000	Green (RoHS & no Sb/Br)	CU NIPDAU	Level-3-260C-168 HR	-40 to 125	65100Q	<a href="#">Samples</a>

(1) The marketing status values are defined as follows:

**ACTIVE:** Product device recommended for new designs.

**LIFEBUY:** TI has announced that the device will be discontinued, and a lifetime-buy period is in effect.

**NRND:** Not recommended for new designs. Device is in production to support existing customers, but TI does not recommend using this part in a new design.

**PREVIEW:** Device has been announced but is not in production. Samples may or may not be available.

**OBSOLETE:** TI has discontinued the production of the device.

(2) **RoHS:** TI defines "RoHS" to mean semiconductor products that are compliant with the current EU RoHS requirements for all 10 RoHS substances, including the requirement that RoHS substance do not exceed 0.1% by weight in homogeneous materials. Where designed to be soldered at high temperatures, "RoHS" products are suitable for use in specified lead-free processes. TI may reference these types of products as "Pb-Free".

**RoHS Exempt:** TI defines "RoHS Exempt" to mean products that contain lead but are compliant with EU RoHS pursuant to a specific EU RoHS exemption.

**Green:** TI defines "Green" to mean the content of Chlorine (Cl) and Bromine (Br) based flame retardants meet JS709B low halogen requirements of <=1000ppm threshold. Antimony trioxide based flame retardants must also meet the <=1000ppm threshold requirement.

(3) MSL, Peak Temp. - The Moisture Sensitivity Level rating according to the JEDEC industry standard classifications, and peak solder temperature.

(4) There may be additional marking, which relates to the logo, the lot trace code information, or the environmental category on the device.

(5) Multiple Device Markings will be inside parentheses. Only one Device Marking contained in parentheses and separated by a "~" will appear on a device. If a line is indented then it is a continuation of the previous line and the two combined represent the entire Device Marking for that device.

(6) Lead/Ball Finish - Orderable Devices may have multiple material finish options. Finish options are separated by a vertical ruled line. Lead/Ball Finish values may wrap to two lines if the finish value exceeds the maximum column width.

**Important Information and Disclaimer:**The information provided on this page represents TI's knowledge and belief as of the date that it is provided. TI bases its knowledge and belief on information provided by third parties, and makes no representation or warranty as to the accuracy of such information. Efforts are underway to better integrate information from third parties. TI has taken and continues to take reasonable steps to provide representative and accurate information but may not have conducted destructive testing or chemical analysis on incoming materials and chemicals. TI and TI suppliers consider certain information to be proprietary, and thus CAS numbers and other limited information may not be available for release.

In no event shall TI's liability arising out of such information exceed the total purchase price of the TI part(s) at issue in this document sold by TI to Customer on an annual basis.

**OTHER QUALIFIED VERSIONS OF TPS65100-Q1 :**

- Catalog: [TPS65100](#)

NOTE: Qualified Version Definitions:

- Catalog - TI's standard catalog product

## TAPE AND REEL INFORMATION

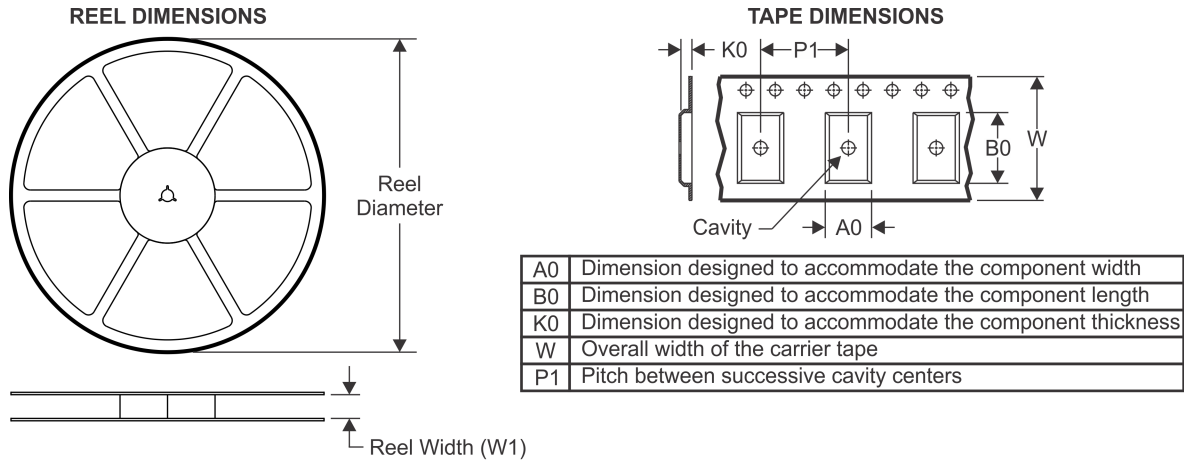

### QUADRANT ASSIGNMENTS FOR PIN 1 ORIENTATION IN TAPE



\*All dimensions are nominal

Device	Package Type	Package Drawing	Pins	SPQ	Reel Diameter (mm)	Reel Width W1 (mm)	A0 (mm)	B0 (mm)	K0 (mm)	P1 (mm)	W (mm)	Pin1 Quadrant
TPS65100QPWPRQ1	HTSSOP	PWP	24	2000	330.0	16.4	6.95	8.3	1.6	8.0	16.0	Q1

**TAPE AND REEL BOX DIMENSIONS**



\*All dimensions are nominal

Device	Package Type	Package Drawing	Pins	SPQ	Length (mm)	Width (mm)	Height (mm)
TPS65100QPWPRQ1	HTSSOP	PWP	24	2000	350.0	350.0	43.0

## GENERIC PACKAGE VIEW

**PWP 24**

**PowerPAD™ TSSOP - 1.2 mm max height**

4.4 x 7.6, 0.65 mm pitch

PLASTIC SMALL OUTLINE

This image is a representation of the package family, actual package may vary.  
Refer to the product data sheet for package details.

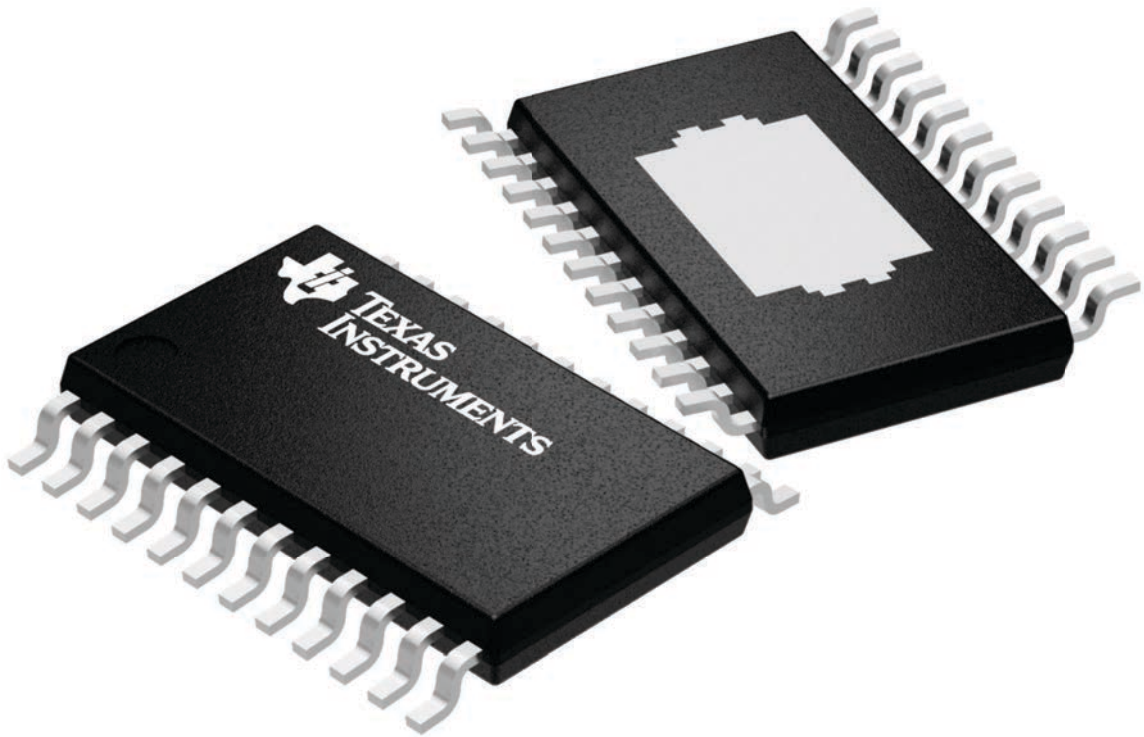

4224742/B

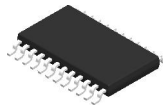

# PACKAGE OUTLINE

## PWP0024B

## PowerPAD™ TSSOP - 1.2 mm max height

PLASTIC SMALL OUTLINE

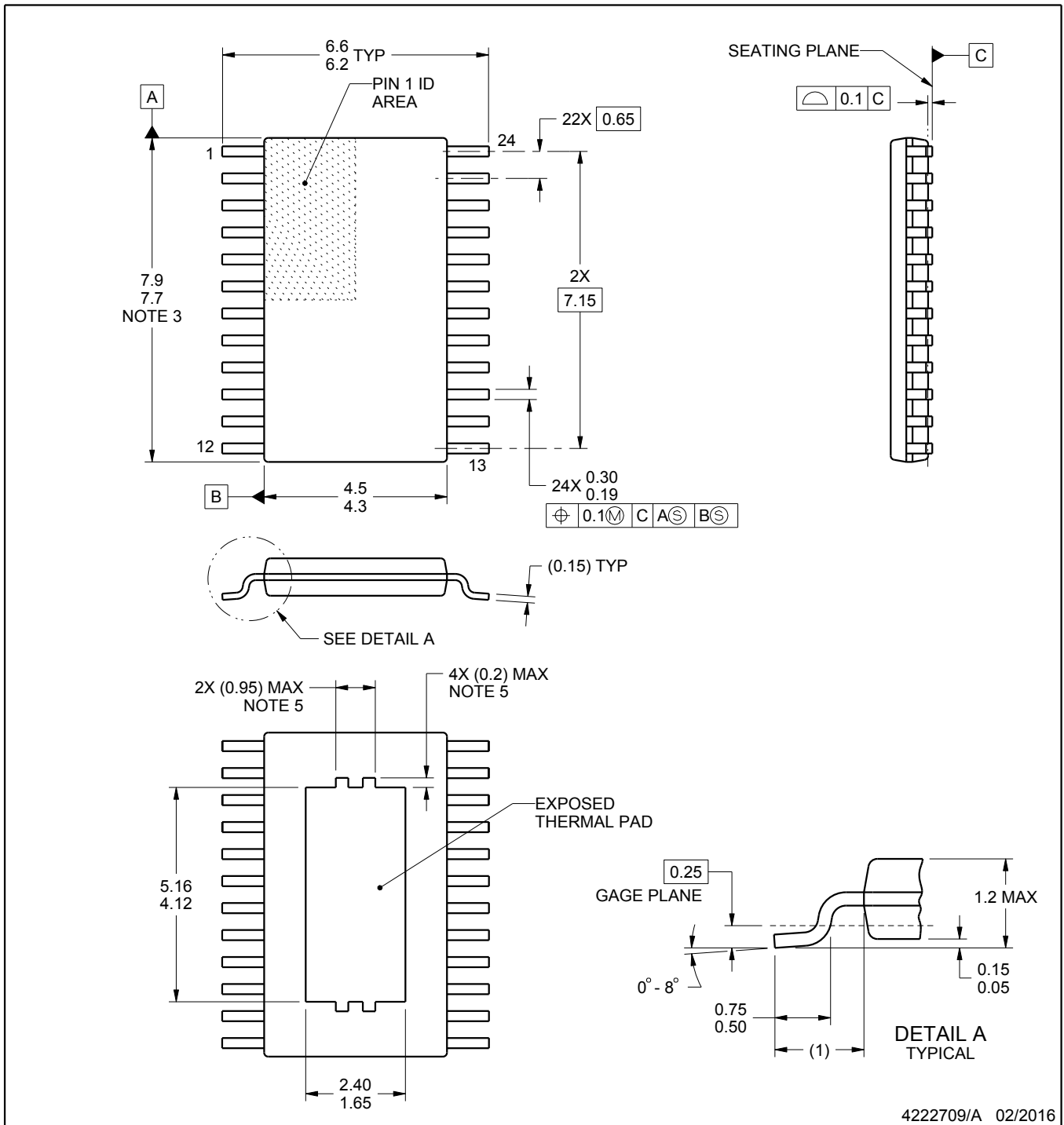

4222709/A 02/2016

### NOTES:

PowerPAD is a trademark of Texas Instruments.

1. All linear dimensions are in millimeters. Any dimensions in parenthesis are for reference only. Dimensioning and tolerancing per ASME Y14.5M.
2. This drawing is subject to change without notice.
3. This dimension does not include mold flash, protrusions, or gate burrs. Mold flash, protrusions, or gate burrs shall not exceed 0.15 mm per side.
4. Reference JEDEC registration MO-153.
5. Features may not be present and may vary.

# EXAMPLE BOARD LAYOUT

PWP0024B

PowerPAD™ TSSOP - 1.2 mm max height

PLASTIC SMALL OUTLINE

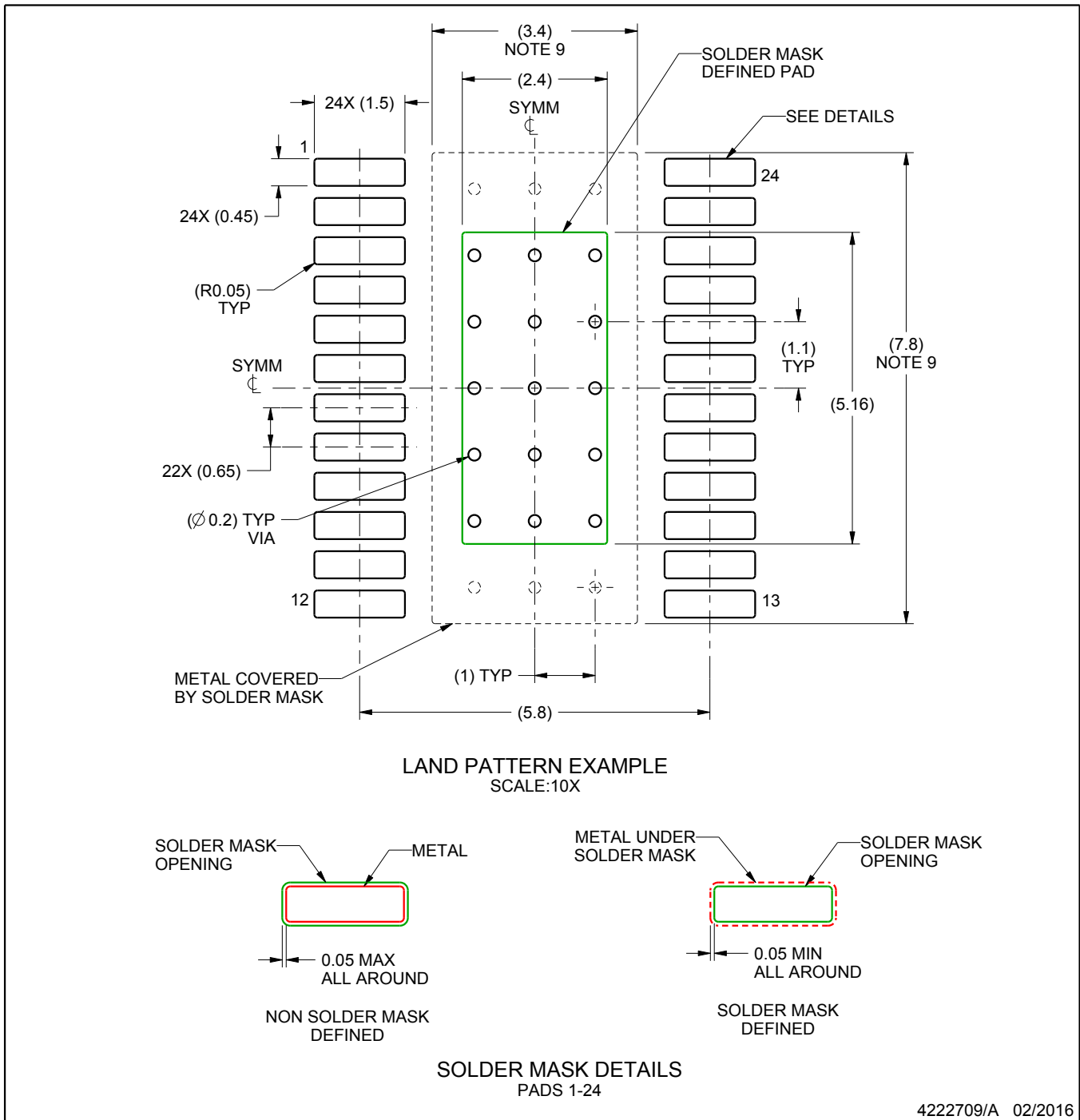

NOTES: (continued)

6. Publication IPC-7351 may have alternate designs.
7. Solder mask tolerances between and around signal pads can vary based on board fabrication site.
8. This package is designed to be soldered to a thermal pad on the board. For more information, see Texas Instruments literature numbers SLMA002 ([www.ti.com/lit/slma002](http://www.ti.com/lit/slma002)) and SLMA004 ([www.ti.com/lit/slma004](http://www.ti.com/lit/slma004)).
9. Size of metal pad may vary due to creepage requirement.

# EXAMPLE STENCIL DESIGN

PWP0024B

PowerPAD™ TSSOP - 1.2 mm max height

PLASTIC SMALL OUTLINE

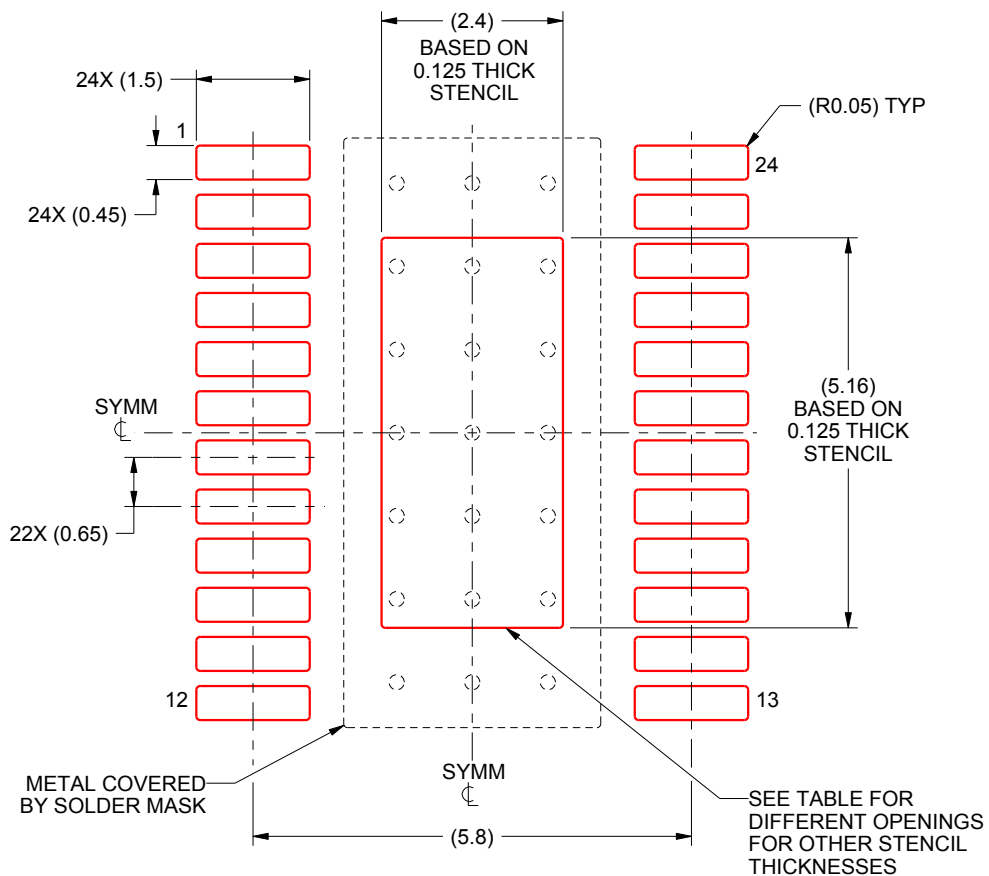

**SOLDER PASTE EXAMPLE**  
 EXPOSED PAD  
 100% PRINTED SOLDER COVERAGE BY AREA  
 SCALE:10X

STENCIL THICKNESS	SOLDER STENCIL OPENING
0.1	2.68 X 5.77
0.125	2.4 X 5.16 (SHOWN)
0.15	2.19 X 4.71
0.175	2.03 X 4.36

4222709/A 02/2016

NOTES: (continued)

- 10. Laser cutting apertures with trapezoidal walls and rounded corners may offer better paste release. IPC-7525 may have alternate design recommendations.
- 11. Board assembly site may have different recommendations for stencil design.

## IMPORTANT NOTICE AND DISCLAIMER

TI PROVIDES TECHNICAL AND RELIABILITY DATA (INCLUDING DATASHEETS), DESIGN RESOURCES (INCLUDING REFERENCE DESIGNS), APPLICATION OR OTHER DESIGN ADVICE, WEB TOOLS, SAFETY INFORMATION, AND OTHER RESOURCES "AS IS" AND WITH ALL FAULTS, AND DISCLAIMS ALL WARRANTIES, EXPRESS AND IMPLIED, INCLUDING WITHOUT LIMITATION ANY IMPLIED WARRANTIES OF MERCHANTABILITY, FITNESS FOR A PARTICULAR PURPOSE OR NON-INFRINGEMENT OF THIRD PARTY INTELLECTUAL PROPERTY RIGHTS.

These resources are intended for skilled developers designing with TI products. You are solely responsible for (1) selecting the appropriate TI products for your application, (2) designing, validating and testing your application, and (3) ensuring your application meets applicable standards, and any other safety, security, or other requirements. These resources are subject to change without notice. TI grants you permission to use these resources only for development of an application that uses the TI products described in the resource. Other reproduction and display of these resources is prohibited. No license is granted to any other TI intellectual property right or to any third party intellectual property right. TI disclaims responsibility for, and you will fully indemnify TI and its representatives against, any claims, damages, costs, losses, and liabilities arising out of your use of these resources.

TI's products are provided subject to TI's Terms of Sale ([www.ti.com/legal/termsofsale.html](http://www.ti.com/legal/termsofsale.html)) or other applicable terms available either on [ti.com](http://ti.com) or provided in conjunction with such TI products. TI's provision of these resources does not expand or otherwise alter TI's applicable warranties or warranty disclaimers for TI products.

Mailing Address: Texas Instruments, Post Office Box 655303, Dallas, Texas 75265  
Copyright © 2019, Texas Instruments Incorporated

## Looking for pricing, stock, or lifecycle information?

Click below to explore more details on WIN SOURCE:

 [View TPS65100QPWPRQ1](#) on WIN SOURCE

 [Texas Instruments](#) Information

## Optimize Your Supply Chain with WIN SOURCE Solutions

-  Global Sourcing Solution
-  Obsolete Management
-  Cost Control Management
-  Shortage Management
-  Alternative Solution
-  Excess Inventory Management