



# THE DATASHEET OF TPS65100RGER



## TPS6510x Triple Output LCD Supply With Linear Regulator and VCOM Buffer

### 1 Features

- 2.7-V to 5.8-V Input Voltage Range
- 1.6-MHz Fixed Switching Frequency
- 3 Independent Adjustable Outputs
- Boost Converter Output Voltage  $V_{O1}$  of up to 15 V With < 1% Output Voltage Accuracy
- Negative Regulated Charge Pump  $V_{O2}$
- Positive Charge Pump  $V_{O3}$
- Integrated VCOM Buffer
- Virtual Synchronous Converter Technology in Boost Converter
- Auxiliary 3.3-V Linear Regulator Controller
- Internal Soft Start
- Internal Power-On Sequencing
- Fault Detection of all Outputs (TPS65100/05)
- No Fault Detection (TPS65101)
- Thermal Shutdown
- Available in TSSOP-24 and VQFN-24 PowerPAD™ Packages

### 2 Applications

- TFT LCD Displays for Notebooks
- TFT LCD Displays for Monitors
- Portable DVD Players
- Tablet PCs
- Car Navigation Systems
- Industrial Displays

### 3 Description

The TPS6510x series offers a compact and small power supply solution that provides all three voltages required by thin film transistor (TFT) LCD displays. The auxiliary linear regulator controller can be used to generate a 3.3-V logic power rail for systems powered by a 5-V supply rail only.

The main output  $V_{O1}$ , is a 1.6-MHz, fixed-frequency PWM boost converter providing the source drive voltage for the LCD display. The device is available in two versions with different internal switch current limits to allow the use of a smaller external inductor when lower output power is required. The TPS65100/01 has a typical switch current limit of 2.3 A, and the TPS65105 has a typical switch current limit of 1.37 A. A fully integrated adjustable charge pump doubler/tripler provides the positive LCD gate drive voltage. An externally adjustable negative charge pump provides the negative gate drive voltage. Due to the high 1.6-MHz switching frequency of the charge pumps, inexpensive and small 220-nF capacitors can be used.

The TPS6510x series has an integrated VCOM buffer to power the LCD backplane. For LCD panels powered by 5 V only, the TPS6510x series has a linear regulator controller using an external transistor to provide a regulated 3.3-V output for the digital circuits. For maximum safety, the TPS65100/05 goes into shutdown as soon as one of the outputs is out of regulation. The device can be enabled again by toggling the input or the enable (EN) pin to GND. The TPS65101 does not enter shutdown when one of the outputs is below its power good threshold.

#### Block Diagram

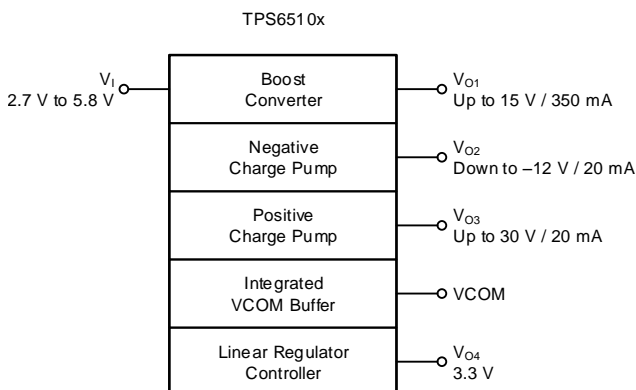

#### Device Information<sup>(1)</sup>

PART NUMBER	PACKAGE	BODY SIZE (NOM)
TPS6510x	HTSSOP (24)	7.80 mm × 4.40 mm
	VQFN (24)	4.00 mm × 4.00 mm

(1) For all available packages, see the orderable addendum at the end of the data sheet.



## Table of Contents

<b>1 Features</b> ..... 1 <b>2 Applications</b> ..... 1 <b>3 Description</b> ..... 1 <b>4 Revision History</b> ..... 2 <b>5 Device Options</b> ..... 3 <b>6 Pin Configuration and Functions</b> ..... 3 <b>7 Specifications</b> ..... 5 7.1 Absolute Maximum Ratings ..... 5 7.2 ESD Ratings..... 5 7.3 Recommended Operating Conditions ..... 5 7.4 Thermal Information ..... 6 7.5 Electrical Characteristics..... 6 7.6 Dissipation Ratings ..... 8 7.7 Typical Characteristics ..... 9 <b>8 Detailed Description</b> ..... 12 8.1 Overview ..... 12 8.2 Functional Block Diagram ..... 13 8.3 Feature Description..... 14 8.4 Device Functional Modes..... 16	<b>9 Application and Implementation</b> ..... 17 9.1 Application Information..... 17 9.2 Typical Applications ..... 17 9.3 System Examples ..... 24 <b>10 Power Supply Recommendations</b> ..... 26 <b>11 Layout</b> ..... 26 11.1 Layout Guidelines ..... 26 11.2 Layout Example ..... 26 11.3 Thermal Performance ..... 27 <b>12 Device and Documentation Support</b> ..... 28 12.1 Device Support..... 28 12.2 Documentation Support ..... 28 12.3 Related Links ..... 28 12.4 Receiving Notification of Documentation Updates 28 12.5 Community Resource..... 28 12.6 Trademarks ..... 28 12.7 Electrostatic Discharge Caution..... 29 12.8 Glossary ..... 29 <b>13 Mechanical, Packaging, and Orderable Information</b> ..... 29
---	---

## 4 Revision History

NOTE: Page numbers for previous revisions may differ from page numbers in the current version.

Changes from Revision C (April 2006) to Revision D	Page
<ul style="list-style-type: none"> <li>• Added <i>ESD Ratings</i> table, <i>Thermal Information</i> table, <i>Feature Description</i> section, <i>Device Functional Modes</i>, <i>Application and Implementation</i> section, <i>Power Supply Recommendations</i> section, <i>Layout</i> section, <i>Device and Documentation Support</i> section, and <i>Mechanical, Packaging, and Orderable Information</i> section ..... 1</li> <li>• Deleted <i>Ordering Information</i> table, see POA at the end of the datasheet. .... 1</li> </ul>	

## 5 Device Options

LINEAR REGULATOR OUTPUT VOLTAGE	MINIMUM SWITCH CURRENT LIMIT	PACKAGE MARKING
3.3 V	1.6 A	TPS65100
3.3 V	1.6 A	TPS65101
3.3 V	0.96 A	TPS65105

## 6 Pin Configuration and Functions

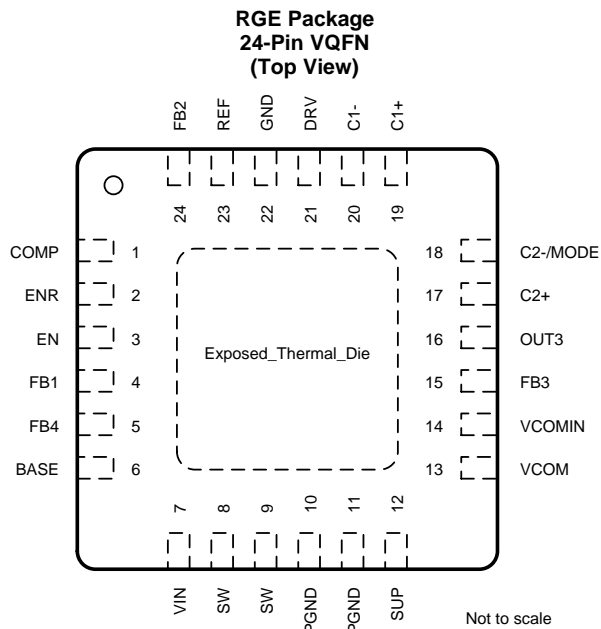
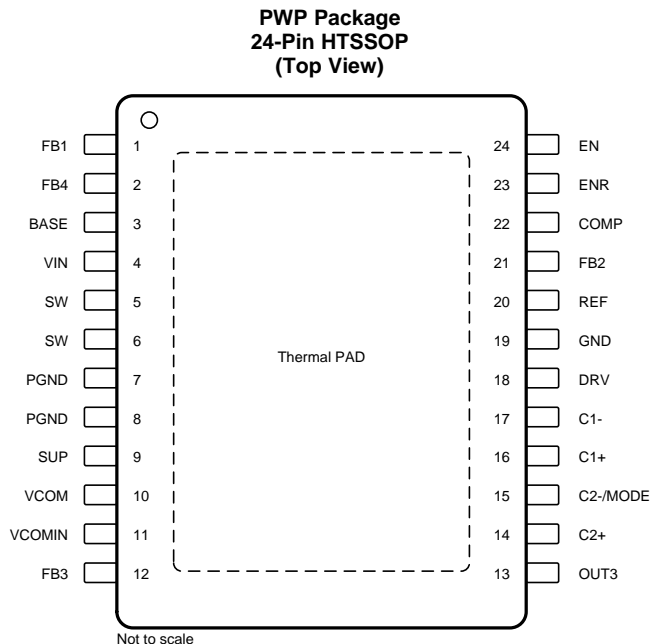

### Pin Functions

NAME	PIN		I/O	DESCRIPTION
	HTSSOP	VQFN		
BASE	3	6	O	Base drive output for the external transistor. If Linear Regulator is not needed pull this pin against VIN.
C1+	16	19	—	Positive terminal of the charge pump flying capacitor
C1-	17	20	—	Negative terminal of the charge pump flying capacitor
C2+	14	17	—	Positive terminal for the charge pump flying capacitor. If the device runs in voltage doubler mode, this pin should be left open.
C2-/MODE	15	18	—	Negative terminal of the charge pump flying capacitor and charge pump MODE pin. If the flying capacitor is connected to this pin, the converter operates in a voltage tripler mode. If the charge pump needs to operate in a voltage doubler mode, the flying capacitor is removed and the C2-/MODE pin should be connected to GND.
COMP	22	1	—	Compensation pin for the main boost converter. A small capacitor is connected to this pin.
DRV	18	21	O	External charge pump driver
EN	24	3	I	Enable pin of the device. This pin should be terminated and not be left floating. A logic high enables the device and a logic low shuts down the device.
ENR	23	2	I	Enable pin of the linear regulator controller. This pin should be terminated and not be left floating. Logic high enables the regulator and a logic low puts the regulator in shutdown.
FB1	1	4	I	Feedback pin of the boost converter
FB2	21	24	I	Feedback pin of negative charge pump
FB3	12	15	I	Feedback pin of positive charge pump
FB4	2	5	I	Feedback pin of the linear regulator controller. The linear regulator controller is set to a fixed output voltage of 3.3 V or 3 V depending on the version.
GND	19	22	—	Ground
OUT3	13	16	O	Positive charge pump output
PGND	7, 8	10, 11	—	Power ground
REF	20	23	O	Internal reference output typically 1.23 V
SUP	9	12	I	Supply pin of the positive, negative charge pump, boost converter gate drive circuit, and VCOM buffer. This pin should be connected to the output of the main boost converter and cannot be connected to any other voltage source. For performance reasons, it is not recommended for a bypass capacitor to be connected directly to this pin.
SW	5, 6	8, 9	—	Switch pin of the boost converter
VCOM	10	13	O	VCOM buffer output
VCOMIN	11	14	I	Positive input terminal of the VCOM buffer. When the VCOM buffer is not used, this terminal can be connected to GND to reduce the overall quiescent current of the IC.
VIN	4	7	I	Input voltage pin of the device
PowerPAD™/ Thermal Die	—	—	—	The PowerPAD or exposed thermal die needs to be connected to the power ground pins (PGND)

## 7 Specifications

### 7.1 Absolute Maximum Ratings

Over operating free-air temperature range (unless otherwise noted)<sup>(1)</sup>

	MIN	MAX	UNIT
Voltages on pin VIN <sup>(2)</sup>	-0.3	6	V
Voltages on pin SUP, PG <sup>(2)</sup>	-0.3	15.5	V
Voltage on pin FB1, FB2, FB3, FB4	-0.3	5.5	V
Voltages on pin EN, MODE, ENR <sup>(2)</sup>	-0.3	V <sub>I</sub> + 0.3	V
Voltage on VCOMIN	-0.3	14	V
Voltage on pin SW <sup>(2)</sup>	-0.3	20	V
Voltage on pin DRV	-0.3	15	V
Voltage on pin REF	-0.3	4	V
Voltage on pin BASE	-0.3	5.5	V
Voltage on pin VOUT3	-0.3	30	V
Voltage on pin VCOM	-0.3	15	V
Voltage on pin C1+, C2+	-0.3	30	V
Voltage on pin C1-, C2-	-0.3	15	V
Continuous power dissipation	See <a href="#">Dissipation Ratings</a>		
Operating junction temperature, T <sub>J</sub>	-40	150	°C
Storage temperature, T <sub>stg</sub>	-65	150	°C

(1) Stresses beyond those listed under *Absolute Maximum Ratings* may cause permanent damage to the device. These are stress ratings only, and functional operation of the device at these or any other conditions beyond those indicated under *Recommended Operating Conditions* is not implied. Exposure to absolute-maximum-rated conditions for extended periods may affect device reliability.

(2) All voltage values are with respect to network ground terminal.

### 7.2 ESD Ratings

		VALUE	UNIT
V <sub>(ESD)</sub>	Electrostatic discharge	Human-body model (HBM), per ANSI/ESDA/JEDEC JS-001 <sup>(1)</sup>	V
		Charged-device model (CDM), per JEDEC specification JESD22-C101 <sup>(2)</sup>	

(1) JEDEC document JEP155 states that 500-V HBM allows safe manufacturing with a standard ESD control process.

(2) JEDEC document JEP157 states that 250-V CDM allows safe manufacturing with a standard ESD control process.

### 7.3 Recommended Operating Conditions

	MIN	NOM	MAX	UNIT
V <sub>I</sub> Input voltage	2.7		5.8	V
L Inductor <sup>(1)</sup>		4.7		μH
T <sub>A</sub> Operating free-air temperature	-40		85	°C
T <sub>J</sub> Operating junction temperature	-40		125	°C

(1) See the [Detailed Design Procedure](#) for further information.

## 7.4 Thermal Information

THERMAL METRIC <sup>(1)</sup>		TPS6510x		UNIT
		PWP (HTSSOP)	RGE (VQFN)	
		24 PINS	24 PINS	
R <sub>θJA</sub>	Junction-to-ambient thermal resistance	37.2	33	°C/W
R <sub>θJC(top)</sub>	Junction-to-case (top) thermal resistance	18.9	35.3	°C/W
R <sub>θJB</sub>	Junction-to-board thermal resistance	16.4	10.7	°C/W
ψ <sub>JT</sub>	Junction-to-top characterization parameter	0.4	0.4	°C/W
ψ <sub>JB</sub>	Junction-to-board characterization parameter	16.2	10.8	°C/W
R <sub>θJC(bot)</sub>	Junction-to-case (bottom) thermal resistance	2.1	1.8	°C/W

(1) For more information about traditional and new thermal metrics, see the [Semiconductor and IC Package Thermal Metrics](#) application report.

## 7.5 Electrical Characteristics

V<sub>I</sub> = 3.3 V, EN = V<sub>I</sub>, V<sub>O1</sub> = 10 V, T<sub>A</sub> = -40°C to 85°C, typical values are at T<sub>A</sub> = 25°C (unless otherwise noted)

PARAMETER	TEST CONDITIONS	MIN	TYP	MAX	UNIT		
<b>SUPPLY CURRENT</b>							
V <sub>I</sub>	Input voltage range	2.7		5.8	V		
I <sub>I(VIN)</sub>	Quiescent current (VIN)	ENR = VCOMIN = GND, V <sub>O3</sub> = 2 × V <sub>O1</sub> Boost converter not switching		0.7	0.9	mA	
I <sub>I(QCharge)</sub>	Charge pump quiescent current (SUP)	V <sub>O1</sub> = SUP = 10 V, V <sub>O3</sub> = 2 × V <sub>O1</sub>		1.7	2.7	mA	
		V <sub>O1</sub> = SUP = 10 V, V <sub>O3</sub> = 3 × V <sub>O1</sub>		3.9	6		
I <sub>I(QVCOM)</sub>	VCOM quiescent current (SUP)	ENR = GND, V <sub>O1</sub> = SUP = 10 V		750	1300	μA	
I <sub>I(QEN)</sub>	LDO controller quiescent current (VIN)	ENR = V <sub>I</sub> , EN = GND		300	800	μA	
I <sub>I(sd)</sub>	Shutdown current (VIN)	EN = ENR = GND		1	10	μA	
V <sub>IT-</sub>	Undervoltage lockout threshold	V <sub>I</sub> falling		2.2	2.4	V	
	Thermal shutdown temperature threshold	T <sub>J</sub> rising		160		°C	
<b>LOGIC SIGNALS</b>							
V <sub>IH</sub>	High-level input voltage (EN, ENR)	1.5			V		
V <sub>IL</sub>	Low-level input voltage (EN, ENR)			0.4	V		
I <sub>IH</sub> , I <sub>IL</sub>	Input leakage current	EN = ENR = GND or V <sub>I</sub>		0.01	0.1	μA	
<b>MAIN BOOST CONVERTER V<sub>O1</sub></b>							
V <sub>O1</sub>	Output voltage range	5		15	V		
V <sub>O1</sub> - V <sub>I</sub>	Minimum input to output voltage difference	1			V		
V <sub>(REF)</sub>	Reference output voltage (REF)	1.205	1.213	1.219	V		
V <sub>ref</sub>	Feedback regulation voltage (FB1)	1.136	1.146	1.154	V		
I <sub>IB</sub>	Feedback input bias current			10	100	nA	
r <sub>DS(on)</sub>	N-MOSFET on-resistance (Q1)	V <sub>O1</sub> = 10 V, I <sub>(sw)</sub> = 500 mA		195	290	mΩ	
		V <sub>O1</sub> = 5 V, I <sub>(sw)</sub> = 500 mA		285	420		
I <sub>LIM</sub>	N-MOSFET switch current limit (Q1)	TPS65100, TPS65101		1.6	2.3	2.6	A
		TPS65105		0.96	1.37	1.56	A
r <sub>DS(on)</sub>	P-MOSFET on-resistance (Q2)	V <sub>O1</sub> = 10 V, I <sub>(sw)</sub> = 100 mA		9	15	Ω	
		V <sub>O1</sub> = 5 V, I <sub>(sw)</sub> = 100 mA		14	22		

**Electrical Characteristics (continued)**
 $V_I = 3.3\text{ V}$ ,  $EN = V_I$ ,  $V_{O1} = 10\text{ V}$ ,  $T_A = -40^\circ\text{C}$  to  $85^\circ\text{C}$ , typical values are at  $T_A = 25^\circ\text{C}$  (unless otherwise noted)

PARAMETER		TEST CONDITIONS	MIN	TYP	MAX	UNIT
	Maximum P-MOSFET peak switch current				1	A
$I_{(SW)(off)}$	Off-state current (SW)	$V_{(sw)} = 15\text{ V}$		1	10	$\mu\text{A}$
$f_{OSC}$	Oscillator frequency	$0^\circ\text{C} \leq T_A \leq 85^\circ\text{C}$	1.295	1.6	2.1	MHz
		$-40^\circ\text{C} \leq T_A \leq 85^\circ\text{C}$	1.191	1.6	2.1	
$\Delta V_{O(\Delta V)}$	Line regulation	$2.7\text{ V} \leq V_I \leq 5.7\text{ V}$ , $I_{load} = 100\text{ mA}$		0.012		%/V
$\Delta V_{O(\Delta I)}$	Load regulation	$0\text{ mA} \leq I_O \leq 300\text{ mA}$		0.2		%/A
<b>NEGATIVE CHARGE PUMP <math>V_{O2}</math></b>						
$V_{O2}$	Output voltage range		-2			V
$V_{(REF)}$	Reference output voltage (REF)		1.205	1.213	1.219	V
$V_{ref}$	Feedback regulation voltage (FB2)		-36	0	36	mV
$I_{IB}$	Feedback input bias current			10	100	nA
$r_{DS(on)}$	Q8 P-Channel switch $r_{DS(on)}$	$I_O = 20\text{ mA}$		4.3	8	$\Omega$
	Q9 N-Channel switch $r_{DS(on)}$			2.9	4.4	
$I_{OM}$	Maximum output current		20			mA
$\Delta V_{O(\Delta V)}$	Line regulation	$7\text{ V} \leq V_{O1} \leq 15\text{ V}$ , $I_O = 10\text{ mA}$ , $V_{O2} = -5\text{ V}$		0.09		%/V
$\Delta V_{O(\Delta I)}$	Load regulation	$1\text{ mA} \leq I_O \leq 20\text{ mA}$ , $V_{O2} = -5\text{ V}$		0.126		%/mA
<b>POSITIVE CHARGE PUMP <math>V_{O3}</math></b>						
$V_{O3}$	Output voltage range				30	V
$V_{(REF)}$	Reference output voltage		1.205	1.213	1.219	V
$V_{ref}$	Feedback regulation voltage (FB3)		1.187	1.214	1.238	V
$I_{IB}$	Feedback input bias current			10	100	nA
$r_{DS(on)}$	Q3 P-Channel switch $r_{DS(on)}$	$I_O = 20\text{ mA}$		9.9	15.5	$\Omega$
	Q4 N-Channel switch $r_{DS(on)}$			1.1	1.8	
	Q5 P-Channel switch $r_{DS(on)}$			4.6	8.5	
	Q6 N-Channel switch $r_{DS(on)}$			1.2	2.2	
$V_d$	D1 – D4 Schottky diode forward voltage	$I_{(D1-D4)} = 40\text{ mA}$		610	720	mV
$I_{OM}$	Maximum output current		20			mA
$\Delta V_{O(\Delta V)}$	Line regulation	$10\text{ V} \leq V_{O1} \leq 15\text{ V}$ , $I_O = 10\text{ mA}$ , $V_{O3} = 27\text{ V}$		0.56		%/V
$\Delta V_{O(\Delta I)}$	Load regulation	$1\text{ mA} \leq I_O \leq 20\text{ mA}$ , $V_{O3} = 27\text{ V}$		0.05		%/mA
<b>LINEAR REGULATOR CONTROLLER <math>V_{O4}</math></b>						
$V_{O4}$	Output voltage range (FB4)	$4.5\text{ V} \leq V_I \leq 5.5\text{ V}$ , $10\text{ mA} \leq I_O \leq 500\text{ mA}$	3.2	3.3	3.4	V
$I_{(BASE)}$	Maximum base drive current	$V_I - V_{O4} - V_{BE} \geq 0.5\text{ V}^{(1)}$	13.5	19		mA
		$V_I - V_{O4} - V_{BE} \geq 0.75\text{ V}^{(1)}$	20	27		
$\Delta V_{O(\Delta V)}$	Line regulation	$4.75\text{ V} \leq V_I \leq 5.5\text{ V}$ , $I_O = 500\text{ mA}$		0.186		%/V
$\Delta V_{O(\Delta I)}$	Load regulation	$1\text{ mA} \leq I_O \leq 500\text{ mA}$ , $V_I = 5\text{ V}$		0.064		%/A
	Start-up current	$V_{O4} \leq 0.8\text{ V}$	11	20	25	mA
<b>VCOM BUFFER</b>						
$V_{cm}$	Common mode input range		2.25		$V_{O1-2}$	V
$V_{lo}$	Input offset voltage (IN)	$I_O = 0\text{ mA}$	-25		25	mV

(1) With  $V_I$  = supply voltage of the TPS6510x,  $V_{O4}$  = output voltage of the regulator,  $V_{BE}$  = basis emitter voltage of external transistor

## Electrical Characteristics (continued)

 $V_I = 3.3\text{ V}$ ,  $EN = V_I$ ,  $V_{O1} = 10\text{ V}$ ,  $T_A = -40^\circ\text{C}$  to  $85^\circ\text{C}$ , typical values are at  $T_A = 25^\circ\text{C}$  (unless otherwise noted)

PARAMETER		TEST CONDITIONS	MIN	TYP	MAX	UNIT
$\Delta V_{O(\Delta I_O)}$	DC Load regulation	$I_O = \pm 25\text{ mA}$	-30		37	mV
		$I_O = \pm 50\text{ mA}$	-45		55	
		$I_O = \pm 100\text{ mA}$	-72		85	
		$I_O = \pm 150\text{ mA}$	-97		110	
$I_{IB}$	Input bias current (IN)		-300	-30	300	nA
$I_{OM}$	Peak output current	$V_{O1} = 15\text{ V}$		1.2		A
		$V_{O1} = 10\text{ V}$		0.65		A
		$V_{O1} = 5\text{ V}$		0.15		A
<b>FAULT PROTECTION THRESHOLDS</b>						
$V_{(th, VO1)}$	Shutdown threshold	$V_{O1}$ Rising	-12% $V_{O1}$	-8.75% $V_{O1}$	-6 $V_{O1}$	V
$V_{(th, VO2)}$		$V_{O2}$ Rising	-13 $V_{O2}$	-9% $V_{O2}$	-5 $V_{O2}$	V
$V_{(th, VO3)}$		$V_{O3}$ Rising	-11 $V_{O3}$	-8% $V_{O3}$	-5 $V_{O3}$	V

## 7.6 Dissipation Ratings

PACKAGE	$R_{\theta JA}$	$T_A \leq 25^\circ\text{C}$ POWER RATING	$T_A = 70^\circ\text{C}$ POWER RATING	$T_A = 85^\circ\text{C}$ POWER RATING
24-Pin TSSOP	30.13 $^\circ\text{C}/\text{W}$ (PWP soldered)	3.3 W	1.83 W	1.32 W
24-Pin VQFN	30 $^\circ\text{C}/\text{W}$	3.3 W	1.8 W	1.3 W

### 7.7 Typical Characteristics

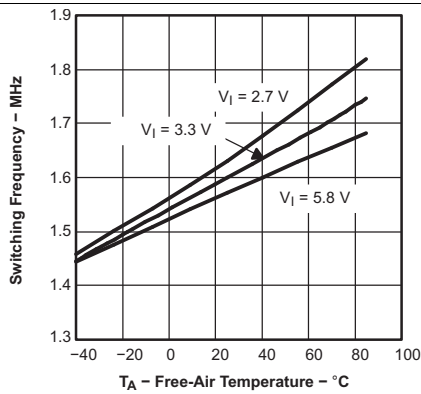

Figure 1. Switching Frequency vs Free-Air Temperature

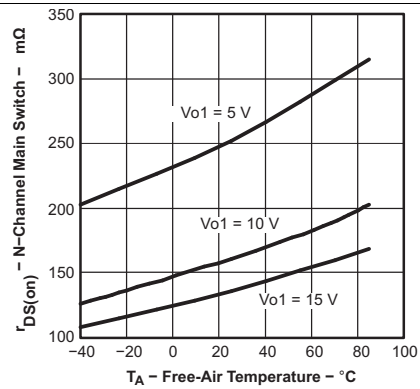

Figure 2.  $r_{DS(on)}$  N-Channel Main Switch vs Free-Air Temperature

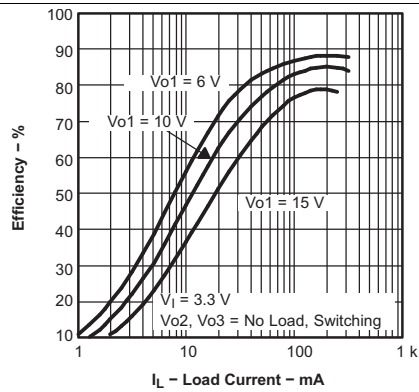

Figure 3. Efficiency vs Load Current

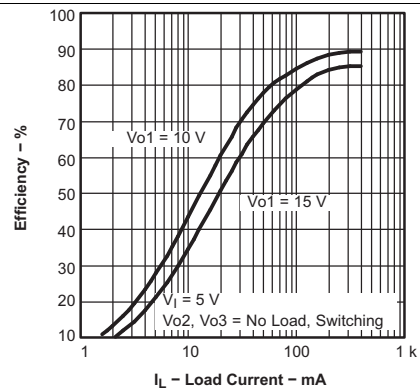

Figure 4. Efficiency vs Load Current

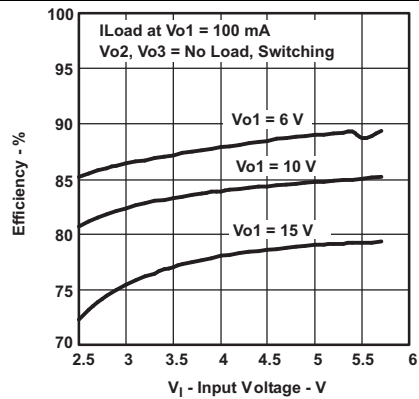

Figure 5. Efficiency vs Input Voltage

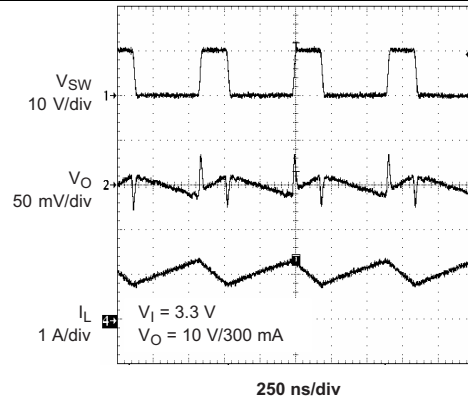
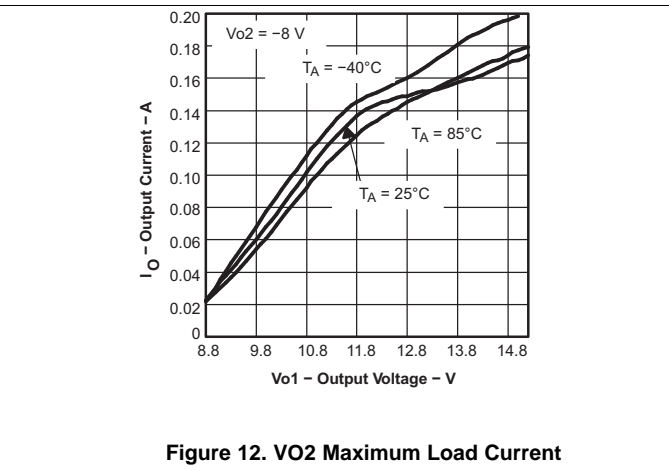
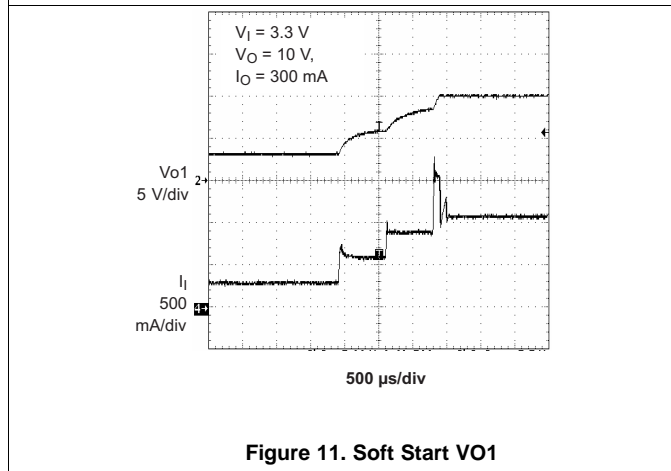
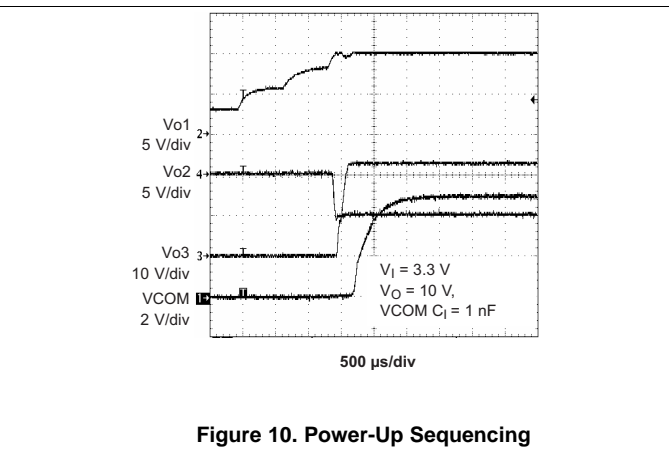
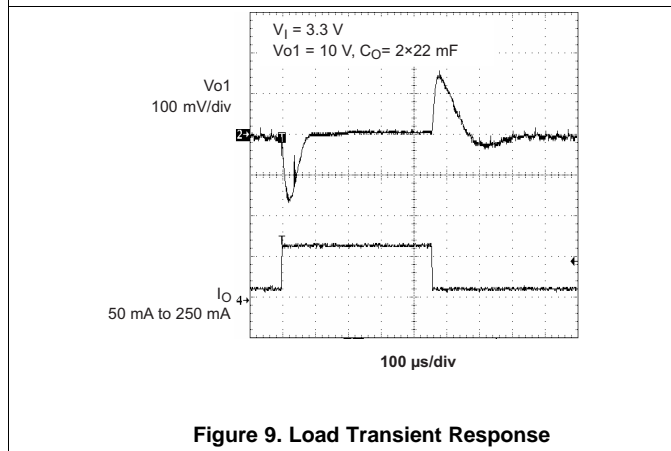
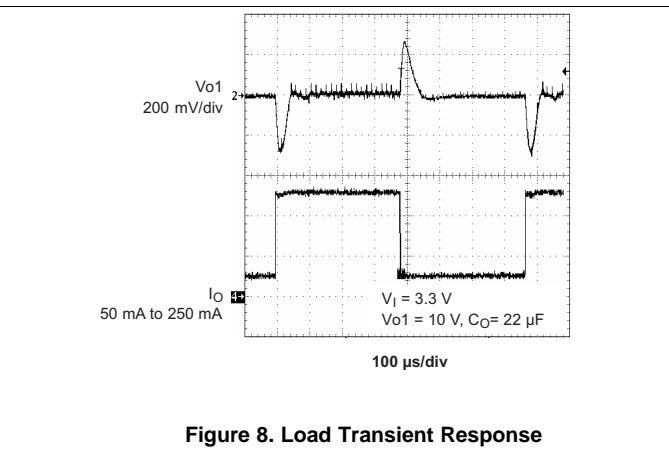
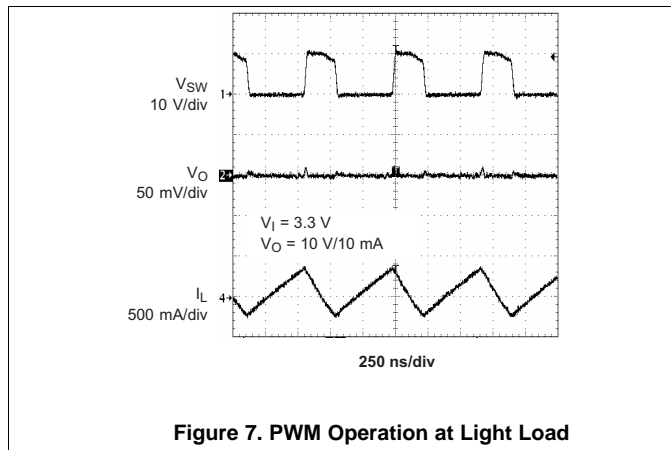
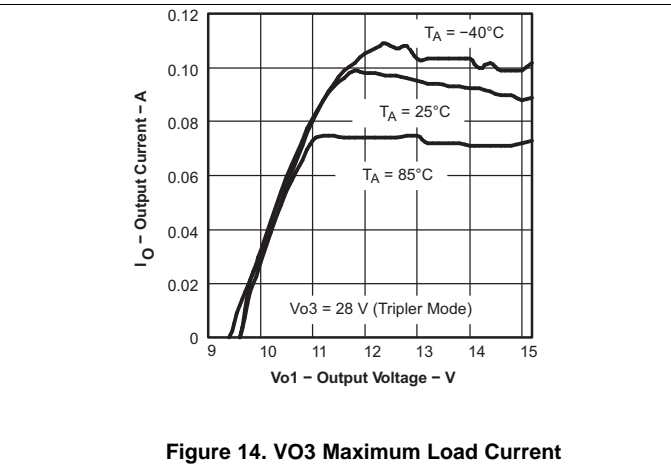
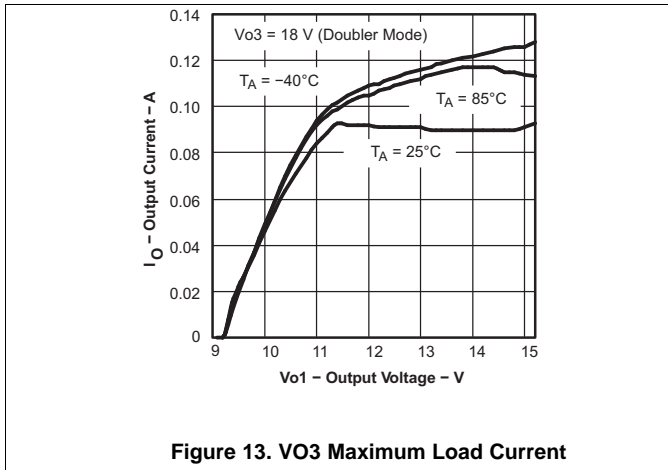

Figure 6. PWM Operation Continuous Mode

Typical Characteristics (continued)



**Typical Characteristics (continued)**



## 8 Detailed Description

### 8.1 Overview

The TPS6510x series consists of a main boost converter operating with a fixed switching frequency of 1.6 MHz to allow for small external components. The boost converter output voltage  $V_{O1}$  is also the input voltage, connected through the pin SUP, for the positive and negative charge pumps and the bias supply for the VCOM buffer. The linear regulator controller is independent from this system with its own enable pin. This allows the linear regulator controller to continue to operate while the other supply rails are disabled or in shutdown due to a fault condition on one of their outputs. See [Functional Block Diagram](#) for more information.

## 8.2 Functional Block Diagram

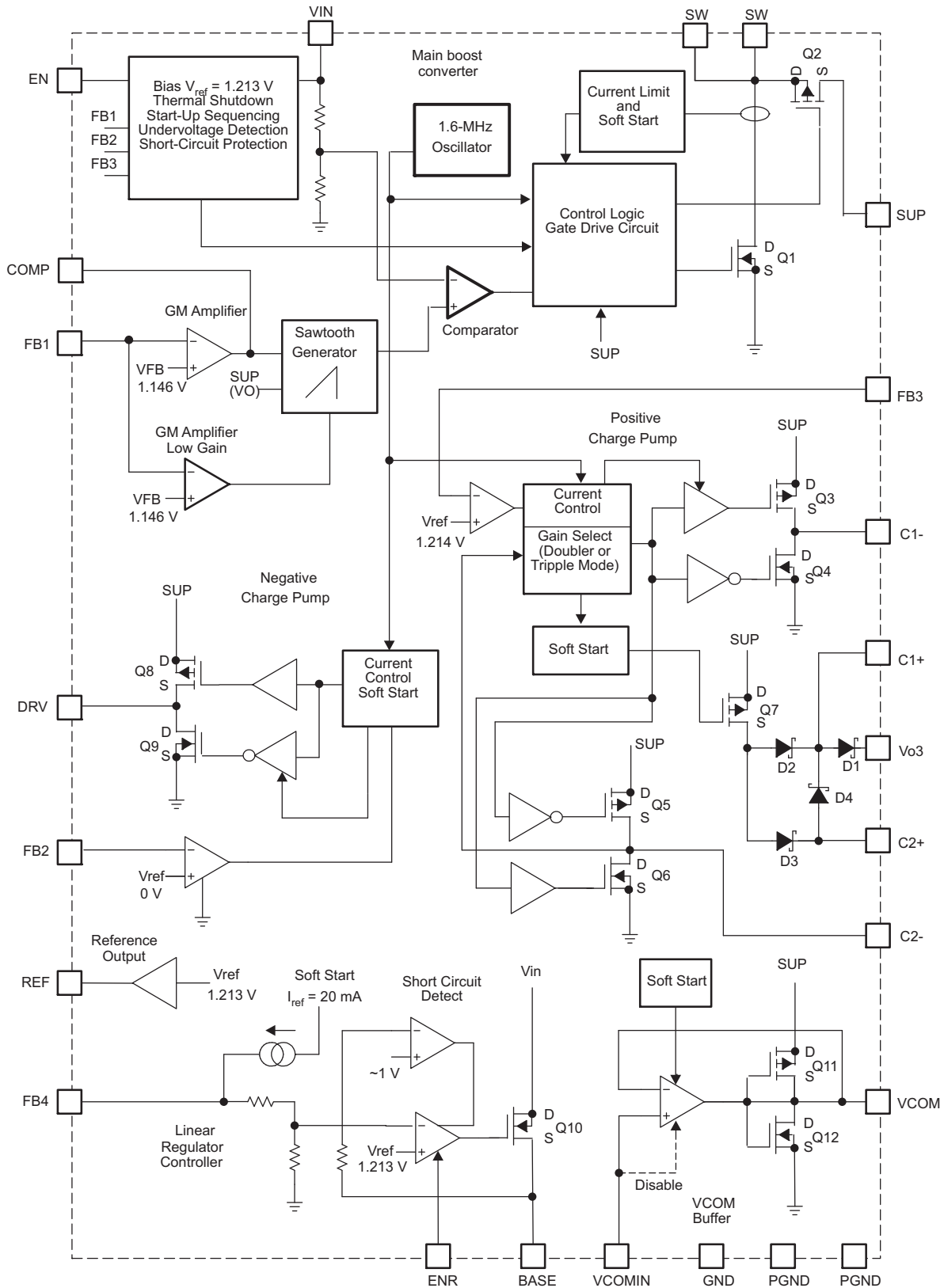

Copyright © 2016, Texas Instruments Incorporated

## 8.3 Feature Description

### 8.3.1 Main Boost Converter

The main boost converter operates with PWM and a fixed switching frequency of 1.6 MHz. The converter uses a unique fast response, voltage mode controller scheme with input voltage feedforward. This achieves excellent line and load regulation (typical is 0.2% A) and allows the use of small external components. To add higher flexibility to the selection of external component values the device uses external loop compensation. Although the boost converter looks like a nonsynchronous boost converter topology operating in discontinuous mode at light load, the TPS6510x series maintains continuous conduction even at light load currents. This is accomplished using the Virtual Synchronous Converter Technology for improved load transient response. This architecture uses an external Schottky diode and an integrated MOSFET in parallel connected between SW and SUP (see the functional block diagram). The integrated MOSFET Q2 allows the inductor current to become negative at light load conditions. For this purpose, a small integrated P-channel MOSFET with typical  $r_{DS(on)}$  of around  $10\ \Omega$  is sufficient. When the inductor current is positive, the external Schottky diode with the lower forward voltage conducts the current. This causes the converter to operate with a fixed frequency in continuous conduction mode over the entire load current range. This avoids the ringing on the switch pin as seen with a standard nonsynchronous boost converter and allows a simpler compensation for the boost converter.

### 8.3.2 VCOM Buffer

VCOMIN is the input of the VCOM buffer. If the VCOM buffer is not required for certain applications, it is possible to shut down the VCOM buffer by statically connecting VCOMIN to ground, reducing the overall quiescent current. The VCOM pin can be left open in this case. The VCOM buffer features soft start avoiding a large voltage drop at  $V_{O1}$  during start-up. During operation the VCOMIN cannot be pulled dynamically to ground.

### 8.3.3 Enable and Power-On Sequencing

The device has two enable pins. These pins should be terminated and not left floating to prevent unpredictable operation. Pulling the enable pin (EN) high enables the device and starts the power on sequencing with the main boost converter  $V_{O1}$  coming up first then the negative and positive charge pump and the VCOM buffer. If the VCOMIN pin is low, the VCOM buffer remains disabled. The linear regulator has an independent enable pin (ENR). Pulling this pin low disables the regulator, and pulling this pin high enables this regulator.

If the enable pin EN is pulled high, the device starts its power on sequencing. The main boost converter starts up first with its soft start. If the output voltage has reached 91.25% of its output voltage, the negative charge pump comes up next. The negative charge pump starts with a soft start and when the output voltage has reached 91% of the nominal value, the positive charge pump comes up with a soft start. The VCOM buffer is enabled as soon as the positive charge pump has reached its nominal value and VCOMIN is greater than typically 1.0 V. Pulling the enable pin low shuts down the device. Depending on load current and output capacitance, each of the outputs goes down.

### 8.3.4 Positive Charge Pump

The TPS6510x series has a fully regulated integrated positive charge pump generating  $V_{O3}$ . The input voltage for the charge pump is applied to the SUP pin that is equal to the output of the main boost converter  $V_{O1}$ . The charge pump is capable of supplying a minimum load current of 20 mA. Depending on the voltage difference between  $V_{O1}$  and  $V_{O3}$  higher load currents are possible.

### 8.3.5 Negative Charge Pump

The TPS6510x series has a regulated negative charge pump using two external Schottky diodes. The input voltage for the charge pump is applied to the SUP pin that is connected to the output of the main boost converter  $V_{O1}$ . The charge pump inverts the main boost converter output voltage and is capable of supplying a minimum load current of 20 mA. Depending on the voltage difference between  $V_{O1}$  and  $V_{O1}$ , higher load currents are possible. See [Figure 12](#).

## Feature Description (continued)

### 8.3.6 Linear Regulator Controller

The TPS6510x series includes a linear regulator controller to generate a 3.3-V rail which is useful when the system is powered from a 5-V supply. The regulator is independent from the other voltage rails of the device and has its own enable (ENR). Since most of the systems require this voltage rail to come up first it is recommended to use a R-C delay on EN. This delays the start-up of the main boost converter which will reduce the inrush current as well. If the linear regulator is not used then it is recommended to pull ENR pin to GND and to pull BASE and FB4 pin to VIN.

### 8.3.7 Soft Start

The main boost converter as well as the charge pumps, linear regulator, and VCOM buffer have an internal soft start. This avoids heavy voltage drops at the input voltage rail or at the output of the main boost converter  $V_{O1}$  during start-up caused by high inrush currents. See [Figure 10](#) and [Figure 11](#). During soft start of the main boost converter  $V_{O1}$  the internal current limit threshold is increased in three steps. The device starts with the first step where the current limit is set to 2/5 of the typical current limit (2/5 of 2.3A) for 1024 clock cycles then increased to 3/5 of the current limit for 1024 clock cycles and the 3rd step is the full current limit. The TPS65101 has an extended soft-start time where each step is 2048 clock cycles.

### 8.3.8 Fault Protection

All the outputs of the TPS65100 and TPS65105 have short-circuit detection where the device enters shutdown. The TPS65101, as an exception, does not enter shutdown in case one of the outputs falls below its power good threshold. The main boost converter has overvoltage and undervoltage protection. If the output voltage  $V_{O1}$  rises above the overvoltage protection threshold of typically 5% of  $V_{O1}$ , then the device stops switching but remains operational. When the output voltage falls below this threshold again, then the converter continues operation. When the output voltage falls below power good threshold of typically 8.75% of  $V_{O1}$ , in case of a short-circuit condition, then the TPS65100 and TPS65105 goes into shutdown. Because there is a direct pass from the input to the output through the diode, the short-circuit condition remains. If this condition needs to be avoided, a fuse at the input or an output disconnect using a single transistor and resistor is required. The negative and positive charge pumps have an undervoltage lockout to protect the LCD panel of possible latch-up conditions in case of a short-circuit condition or faulty operation. When the negative output voltage is typically above 9.5% of its output voltage (closer to ground), then the device enters shutdown. When the positive charge pump output voltage  $V_{O3}$  is below 8% typical of its output voltage, then the device goes into shutdown as well.

See the fault protection thresholds section in the [Electrical Characteristics](#) table. The device can be enabled again by toggling the enable pin EN below 0.4 V or by cycling the input voltage below the undervoltage threshold of 2.2 V. The linear regulator reduces the output current to typical 20 mA under a short-circuit condition when the output voltage is typically < 1 V. See the [Functional Block Diagram](#). The linear regulator does not go into shutdown under a short-circuit condition.

### 8.3.9 Thermal Shutdown

A thermal shutdown is implemented to prevent damage due to excessive heat and power dissipation. Typically, the thermal shutdown threshold is 160°C. If this temperature is reached, the device goes into shutdown. The device can be enabled by toggling the enable pin to low and back to high or by cycling the input voltage to GND and back to  $V_I$  again.

### 8.3.10 Linear Regulator Controller

The TPS6510x series includes a linear regulator controller to generate a 3.3-V rail when the system is powered from a 5-V supply. Because an external NPN transistor is required, the input voltage of the TPS6510x series applied to  $V_I$  needs to be higher than the output voltage of the regulator. To provide a minimum base drive current of 13.5 mA, a minimum internal voltage drop of 500 mV from  $V_I$  to  $V_{(BASE)}$  is required.

This can be translated into a minimum input voltage on  $V_I$  for a certain output voltage as [Equation 1](#) shows:

$$V_{I(\min)} = V_{O4} + V_{BE} + 0.5 \text{ V} \quad (1)$$

## Feature Description (continued)

The base drive current together with the  $h_{FE}$  of the external transistor determines the possible output current. Using a standard NPN transistor like the BCP68 allows an output current of 1 A and using the BCP54 allows a load current of 337 mA for an input voltage of 5 V. Other transistors can be used as well depending on the required output current, power dissipation, and PCB space. The device is stable with a 4.7- $\mu$ F ceramic output capacitor. Larger output capacitor values can be used to improve the load transient response when higher load currents are required.

### 8.4 Device Functional Modes

#### 8.4.1 Enable and Disable

$V_I \geq V_{IT+}$ : When the input voltage is above the undervoltage lockout threshold, the device is turned on and the power-on sequencing starts.

$V_I \leq V_{IT-}$ : When the input voltage is below the undervoltage lockout threshold, the device turns off and all functions are disabled.

#### 8.4.2 Fault Mode

##### 8.4.2.1 Overvoltage Protection

$V_{O1} > 105\%$  of  $V_{O1}$  (typical): device stops switching but remains operational. When the output falls below this threshold, the converter continues operation.

##### 8.4.2.2 Short-Circuit Protection

$V_{O1} < 91.25\%$  of  $V_{O1}$  (typical): device goes into shutdown. Because there is a direct pass from input to output through the diode, the short-circuit condition remains. A fuse at the input or an output disconnect can avoid this condition.

$V_{O2} < 91\%$  of  $V_{O2}$  (typical): device goes into shutdown. The device can be enabled by toggling the enable pin (EN) below 0.4 V or by cycling the input voltage below  $V_{IT-}$ .

$V_{O3} < 92\%$  of  $V_{O3}$  (typical): device goes into shutdown. The device can be enabled by toggling the enable pin (EN) below 0.4 V or by cycling the input voltage below  $V_{IT-}$ .

$V_{O4} < 1$  V (typical): linear regulator reduces output current to typical 20 mA. It does not go into shutdown.

## 9 Application and Implementation

### NOTE

Information in the following applications sections is not part of the TI component specification, and TI does not warrant its accuracy or completeness. TI's customers are responsible for determining suitability of components for their purposes. Customers should validate and test their design implementation to confirm system functionality.

### 9.1 Application Information

The TPS6510x series provides all three voltages that are required for (TFT) LCD displays. The auxiliary linear regulator controller can be used to generate a 3.3-V logic power rail for systems powered by a 5-V supply rail only. Additionally it has an integrated VCOM buffer to power the LCD backplane.

### 9.2 Typical Applications

Figure 15 shows a typical application circuit for a display panel power by a 5-V supply rail. It generates up to 350 mA at 15 V to drive the source driver and 20 mA at 30 V and -12 V to drive the gate drivers.

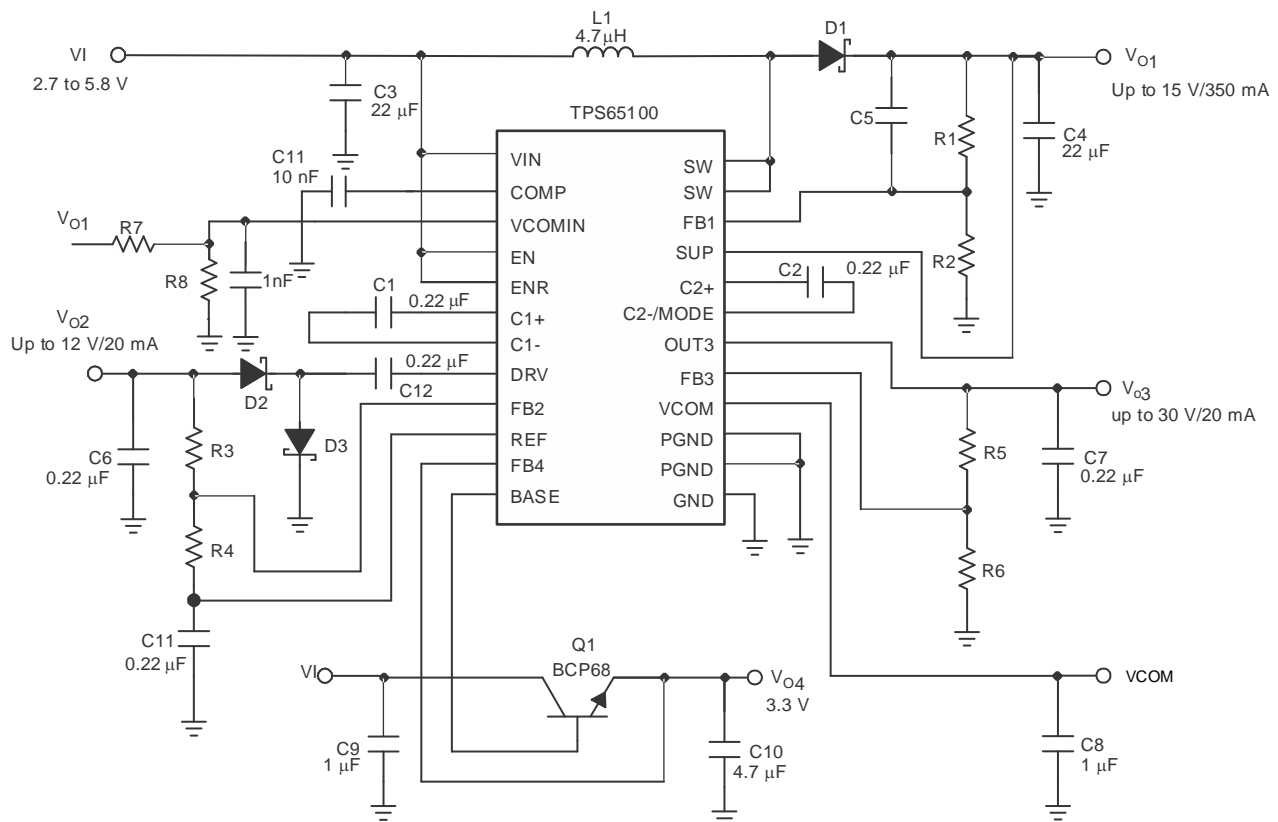

Copyright © 2016, Texas Instruments Incorporated

Figure 15. Typical Application Circuit

## Typical Applications (continued)

### 9.2.1 Design Requirements

Table 1 shows the design parameters for this example.

**Table 1. Design Parameters**

PARAMETER	VALUE
$V_I$ Input supply voltage	3.3 V
$V_{O1}$ Boost converter output voltage and current	10 V at 300 mA
$V_{O1(PP)}$ Boost converter peak-to-peak output voltage ripple	1% = 10 mV
$V_{(SW)}$ Switch voltage drop	0.5 V
$V_F$ Schottky diode forward voltage drop	0.8 V
$V_{O2}$ Positive charge pump output voltage and current	23 V at 20 mA
$V_{O2(PP)}$ Positive charge pump peak-to-peak output voltage ripple	100 mV
$V_{O3}$ Negative charge pump output voltage and current	-5 V at 20 mA
$V_{O3(PP)}$ Negative charge pump peak-to-peak output voltage ripple	100 mV

### 9.2.2 Detailed Design Procedure

#### 9.2.2.1 Boost Converter Design Procedure

The first step in the design procedure is to calculate the maximum possible output current of the main boost converter = 10 V.

1. Duty cycle:

$$D = \frac{V_{O1} + V_F - V_I}{V_{O1} + V_F - V_{SW}} = \frac{10 \text{ V} + 0.8 \text{ V} - 3.3 \text{ V}}{10 \text{ V} + 0.8 \text{ V} - 0.5 \text{ V}} = 0.73 \quad (2)$$

2. Average inductor current:

$$I_L = \frac{I_{O1}}{1 - D} = \frac{300 \text{ mA}}{1 - 0.73} = 1.1 \text{ A} \quad (3)$$

3. Inductor peak-to-peak ripple current:

$$\Delta i_L = \frac{(V_I - V_{SW}) \times D}{f_{osc} \times L} = \frac{(3.3 \text{ V} - 0.5 \text{ V}) \times 0.73}{1.6 \text{ MHz} \times 4.7 \text{ } \mu\text{H}} = 271 \text{ mA} \quad (4)$$

4. Peak switch current:

$$I_{(SW)M} = I_L + \frac{\Delta i_L}{2} = 1.1 \text{ A} + \frac{271 \text{ mA}}{2} = 1.24 \text{ A} \quad (5)$$

The integrated switch, the inductor and the external Schottky diode must be able to handle the peak switch current. The calculated peak switch current has to be equal or lower than the minimum N-MOSFET switch current limit (Q1) as specified in the electrical characteristics table (1.6 A for the TPS65100/01 and 0.96 A for the TPS65105).

If the peak switch current is higher, then the converter cannot support the required load current. This calculation must be done for the minimum input voltage where the peak switch current is highest. The calculation includes conduction losses like switch  $r_{DS(on)}$  and diode forward drop voltage losses. Additional switching losses, inductor core and winding losses, etc., require a slightly higher peak switch current in the actual application. The above calculation still allows an estimate for a good design and component selection.

### 9.2.2.1.1 Inductor Selection

Several inductors work with the TPS6510x series. Especially with the external compensation, the performance can be adjusted to the specific application requirements. The main parameter for inductor selection is the saturation current of the inductor which should be higher than the peak switch current as calculated above with additional margin to cover for heavy load transients and extreme start-up conditions. Another method is to choose the inductor with a saturation current at least as high as the minimum switch current limit of 1.6 A for the TPS65100/01 and 0.96 A for the TPS65105. The different switch current limits allow selection of a physically smaller inductor when less output current is required. The second important parameter is inductor DC resistance.

Usually, the lower the DC resistance, the higher the efficiency. However, inductor DC resistance, is not the only parameter determining the efficiency. Especially for a boost converter where the inductor is the energy storage element the type and material of the inductor influences the efficiency as well. Especially at the high switching frequency of 1.6 MHz, inductor core losses, proximity effects, and skin effects become more important. Usually, an inductor with a larger form factor yields higher efficiency. The efficiency difference between different inductors can vary between 2% to 10%.

For the TPS6510x series, inductor values between 3.3  $\mu\text{H}$  and 6.8  $\mu\text{H}$  are a good choice but other values can be used as well. Possible inductors are shown in [Table 2](#).

**Table 2. Inductor Selection**

DEVICE	INDUCTOR VALUE	COMPONENT SUPPLIER	DIMENSIONS / mm	I <sub>SAT</sub> / DCR
TPS65100	4.7 $\mu\text{H}$	Coilcraft DO1813P-472HC	8,89 x 6,1 x 5	2.6 A/54 m $\Omega$
	4.2 $\mu\text{H}$	Sumida CDRH5D28 4R2	5,7 x 5,7 x 3	2.2 A/23 m $\Omega$
	4.7 $\mu\text{H}$	Sumida CDC5D23 4R7	6 x 6 x 2,5	1.6 A/48 m $\Omega$
	3.3 $\mu\text{H}$	Wuerth Elektronik 744042003	4,8 x 4,8 x 2	1.8 A/65 m $\Omega$
	4.2 $\mu\text{H}$	Sumida CDRH6D12 4R2	6,5 x 6,5 x 1,5	1.8 A/60 m $\Omega$
	3.3 $\mu\text{H}$	Sumida CDRH6D12 3R3	6,5 x 6,5 x 1,5	1.9 A/50 m $\Omega$
TPS65105	3.3 $\mu\text{H}$	Sumida CDPH4D19 3R3	5,1 x 5,1 x 2	1.5 A/26 m $\Omega$
	3.3 $\mu\text{H}$	Coilcraft DO1606T-332	6,5 x 5,2 x 2	1.4 A/120 m $\Omega$
	3.3 $\mu\text{H}$	Sumida CDRH2D18/HP 3R3	3,2 x 3,2 x 2	1.45 A/69 m $\Omega$
	4.7 $\mu\text{H}$	Wuerth Elektronik 744010004	5,5 x 3,5 x 1	1.0 A/260 m $\Omega$
	3.3 $\mu\text{H}$	Coilcraft LPO6610-332M	6,6 x 5,5 x 1	1.3 A/160 m $\Omega$

### 9.2.2.1.2 Output Capacitor Selection

For the best output voltage filtering, a low ESR output capacitor is recommended. Ceramic capacitors have a low ESR value, but depending on the application, tantalum capacitors can be used as well. A 22- $\mu\text{F}$  ceramic output capacitor works for most of the applications. Higher capacitor values can be used to improve the load transient regulation. See [Table 3](#) for selection of the output capacitor. The output voltage ripple can be calculated as:

$$\Delta V_{O1} = \frac{I_{O1}}{C_O} \times \left( \frac{1}{f_{OSC}} - \frac{I_{(SW)M} \times L}{V_{O1} + V_F - V_I} \right) + I_{(SW)M} \times ESR$$

where

- $I_{(SW)M}$  = Peak switch current as calculated in the previous section with  $I_{(SW)M}$
- L = Selected inductor value
- $I_O$  = Normal load current
- $f_{osc}$  = Switching frequency
- $V_F$  = Rectifier diode forward voltage (typical 0.3 V)
- $C_O$  = Selected output capacitor
- ESR = Output capacitor ESR value

(6)

### 9.2.2.1.3 Input Capacitor Selection

For good input voltage filtering, low ESR ceramic capacitors are recommended. A 22- $\mu\text{F}$  ceramic input capacitor is sufficient for most of the applications. For better input voltage filtering, this value can be increased. See [Table 3](#) for input capacitor recommendations.

**Table 3. Input and Output Capacitors Selection**

CAPACITOR	VOLTAGE RATING	COMPONENT SUPPLIER	COMMENTS
22 $\mu$ F/1210	16 V	Taiyo Yuden EMK325BY226MM	output capacitor C <sub>O</sub>
22 $\mu$ F/1206	6.3 V	Taiyo Yuden JMK316BJ226	input capacitor C <sub>I</sub>

#### 9.2.2.1.4 Rectifier Diode Selection

A Schottky diode is recommended to achieve good efficiency as the forward voltage drop is lower than of silicon diodes. The following table shows criteria which should be considered when choosing the rectifier diode:

**Table 4. Rectifier Diode Selection Requirements**

PARAMETER	VALUE	Comment
Voltage Rating	$\geq V_{O1(M)}$	Higher than maximum output voltage of boost converter
Average Forward Current	$\geq I_O$	Higher than the output current
Peak Current	$> I_{L(PP)}$	Higher than the inductor peak current
Forward voltage drop, reverse leakage current	Low as possible	For good efficiency

Possible diodes are: On Semiconductor MBRM120L, Microsemi UPS120E, and Fairchild Semiconductor MBRS130L.

#### 9.2.2.1.5 Converter Loop Design and Stability

The TPS6510x series converter loop can be externally compensated and allows access to the internal transconductance error amplifier output at the COMP pin. A small feedforward capacitor across the upper feedback resistor divider speeds up the circuit as well. To test the converter stability and load transient performance of the converter, a load step from 50 mA to 250 mA is applied, and the output voltage of the converter is monitored. Applying load steps to the converter output is a good tool to judge the stability of such a boost converter. Please refer to SLVA381 to understand the relationship between the phase margin in an AC loop response and the ringing in a load-step

#### 9.2.2.1.6 Design Procedure Quick Steps

1. Select the feedback resistor divider to set the output voltage.
2. Select the feedforward capacitor to place a zero at 50 kHz.
3. Select the compensation capacitor on pin COMP. The smaller the value, the higher the low frequency gain.
4. Use a 50-k $\Omega$  potentiometer in series to C<sub>c</sub> and monitor V<sub>O1</sub> during load transients. Fine tune the load transient by adjusting the potentiometer. Select a resistor value that comes closest to the potentiometer resistor value. This needs to be done at the highest V<sub>I</sub> and highest load current since the stability is most critical at these conditions.

#### 9.2.2.1.7 Setting the Output Voltage and Selecting the Feedforward Capacitor

The output voltage is set by the external resistor divider and is calculated as:

$$V_{O1} = V_{ref} \times \left( 1 + \frac{R_1}{R_2} \right) \quad (7)$$

Across the upper resistor a bypass capacitor is required to speed up the circuit during load transients as shown in [Figure 16](#).

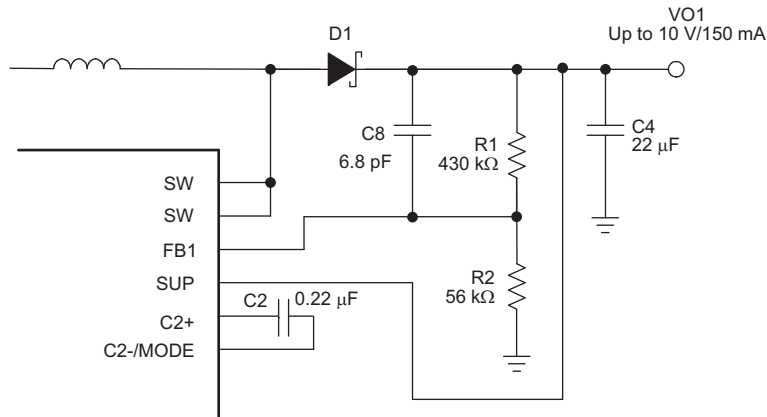

Copyright © 2016, Texas Instruments Incorporated

**Figure 16. Feedforward Capacitor**

Together with R1 the bypass capacitor C8 sets a zero in the control loop at approximately 50 kHz:

$$f_z = \frac{1}{20 \times \pi \times C8 \times R1} \quad (8)$$

A value closest to the calculated value should be used. Larger feedforward capacitor values reduce the load regulation of the converter and cause DC voltage changes as shown in [Figure 17](#).

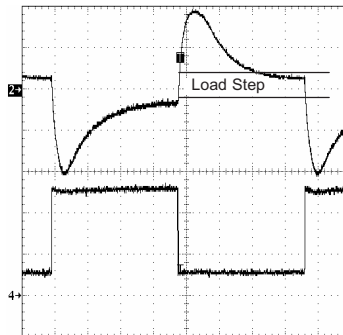

**Figure 17. Load Regulation Caused by a Too Large Feedforward Capacitor Value**

### 9.2.2.2 Negative Charge Pump

The negative charge pump provides a regulated output voltage by inverting the main output voltage  $V_{O1}$ . The negative charge pump output voltage is set with external feedback resistors.

The maximum load current of the negative charge pump depends on the voltage drop across the external Schottky diodes, the internal on resistance of the charge pump MOSFETS Q8 and Q9, and the impedance of the flying capacitor C12. When the voltage drop across these components is larger than the voltage difference from  $V_{O1}$  to  $V_{O2}$ , the charge pump is in dropout, providing the maximum possible output current.

Therefore, the higher the voltage difference between  $V_{O1}$  and  $V_{O2}$ , the higher the possible load current. See [Figure 12](#) for the possible output current versus boost converter voltage  $V_{O1}$ .

$$V_{O2(max)} = -(V_{O1} - 2V_F - I_O(2 \times r_{DS(on)Q8} + 2 \times r_{DS(on)Q9})) \quad (9)$$

Setting the output voltage:

$$V_{O2} = -1.213 \text{ V} \times \left( \frac{R_3}{R_4} \right)$$

$$R3 = R4 \times \left( \frac{|V_{O2}|}{1.213 \text{ V}} \right)$$

The lower feedback resistor value R4 should be in a range between 40 kΩ to 120 kΩ or the overall feedback resistance should be within 500 kΩ to 1 MΩ. Smaller values load the reference too heavily and larger values may cause stability problems. The negative charge pump requires two external Schottky diodes. The peak current rating of the Schottky diode has to be twice the load current of the output. For a 20-mA output current, the dual Schottky diode BAT54 or similar is a good choice.

### 9.2.2.3 Positive Charge Pump

The positive charge pump can be operated in a voltage doubler mode or a voltage tripler mode depending on the configuration of the C2+ and C2-/MODE pins. To operate in a voltage doubler leave the C2+ pin open and connect C2-/MODE to GND. To operate the charge pump in the voltage tripler mode, a flying capacitor needs to be connected between C2+ and C2-/MODE.

The maximum load current of the positive charge pump depends on the voltage drop across the internal Schottky diodes, the internal on resistance of the charge pump MOSFETS, and the impedance of the flying capacitor. When the voltage drop across these components is larger than the voltage difference  $V_{O1} \times 2$  to  $V_{O3}$  (doubler mode) or  $V_{O1} \times 3$  to  $V_{O3}$  (tripler mode), then the charge pump is in dropout, providing the maximum possible output current. Therefore, the higher the voltage difference between  $2 \times V_{O1}$  or  $3 \times V_{O1}$  to  $V_{O3}$ , the higher the possible load current. See [Figure 13](#) and [Figure 14](#) for the output current versus boost converter voltage  $V_{O1}$  and the following calculations. The following graph shows voltage ranges of a doubler and tripler depending of the boost converter voltage  $V_{O1}$ .

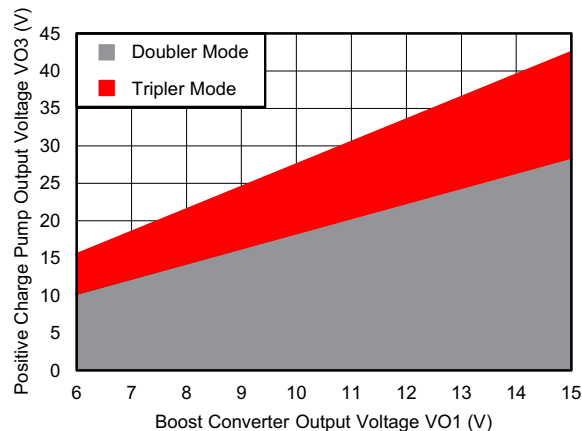

**Figure 18. Positive Charge Pump – Output Ranges for  $I_O = 20 \text{ mA}$**

[Table 5](#) gives first order formulas to calculate the minimum and maximum output voltages of the positive charge pump.

**Table 5. Voltage Limitation Positive Charge Pump**

MODE		EQUATION
Doubler	Minimum output voltage	$V_{O3(\text{min}_d)} = V_{O1}$
	Maximum output voltage	$V_{O3(\text{max}_d)} = 2 \times V_{O1} - (2 \times V_F + 2 \times I_O \cdot (2 \times r_{DS(\text{on})Q5} + r_{DS(\text{on})Q3} + r_{DS(\text{on})Q4} ))$
Tripler	Minimum output voltage	$V_{O3(\text{min}_t)} = V_{O3(\text{max}_d)}$
	Maximum output voltage	$V_{O3(\text{max}_t)} = 3 \times V_{O1} - (4 \times V_F + 2 \times I_O \cdot (3 \times r_{DS(\text{on})Q5} + r_{DS(\text{on})Q3} + r_{DS(\text{on})Q4} ))$

The output voltage is set by the external resistor divider and is calculated as:

$$V_{O3} = 1.214 \text{ V} \times \left( 1 + \frac{R5}{R6} \right) \quad (10)$$

$$R5 = R6 \times \left( \frac{|V_{O3}|}{1.214 \text{ V}} - 1 \right) \quad (11)$$

#### 9.2.2.4 VCOM Buffer

The VCOM buffer is typically used to drive the backplane of a TFT panel. The VCOM output voltage is typically set to half of the main output voltage  $V_{O1}$  plus a small shift to implement the specific compensation voltage. The TFT video signal gets coupled through the TFT storage capacitor plus the LCD cell capacitance to the output of the VCOM buffer. Because of these, short current pulses in the positive and negative direction appear at the output of the VCOM buffer. To minimize the output voltage ripple caused by the current pulses, a transconductance amplifier having a current source output and an output capacitor is used. The output capacitor supports the high frequency part of the current pulses drawn from the LCD panel. The VCOM buffer only needs to handle the low frequency portion of the current pulses. A 1- $\mu$ F ceramic output capacitor is sufficient for most of the applications.

The VCOM buffer has an integrated soft start to avoid voltage drops on  $V_{O1}$  during start-up. The soft start is implemented as such that the VCOMIN is held low until the VCOM buffer is fully biased and the common mode range is reached. Then the positive input is released and the VCOM buffer output slowly comes up. Usually a 1-nF capacitor on VCOMIN to GND is used to filter high frequency noise coupled in from  $V_{O1}$ . The size of this capacitor together with the upper feedback resistor value determines the start-up time. The larger the capacitor from VCOMIN to GND, the slower the start-up time.

#### 9.2.3 Application Curves

Table 6 lists the application curves.

**Table 6. Table of Graphs**

			FIGURE
<b>MAIN BOOST CONVERTER (<math>V_{OUT1}</math>)</b>			
	PWM operation at light load		<a href="#">Figure 7</a>
	Load transient response, $C_O = 22 \mu\text{F}$		<a href="#">Figure 8</a>
	Load transient response, $C_O = 2 \times 22 \mu\text{F}$		<a href="#">Figure 9</a>
	Power-up sequencing		<a href="#">Figure 10</a>
	Soft start $V_{O1}$		<a href="#">Figure 11</a>
<b>NEGATIVE CHARGE PUMP</b>			
$I_{OM}$	$V_{O2}$ Maximum load current	vs Output voltage $V_{O1}$	<a href="#">Figure 12</a>
<b>POSITIVE CHARGE PUMP</b>			
$I_{OM}$	$V_{O3}$ Maximum load current	vs Output voltage $V_{O1}$ (doubler mode)	<a href="#">Figure 13</a>
$I_{OM}$	$V_{O3}$ Maximum load current	vs Output voltage $V_{O1}$ (trippler mode)	<a href="#">Figure 14</a>

## 9.3 System Examples

### 9.3.1 Notebook Supply

Figure 19 shows a typical application circuit suitable to supply (TFT) LCD displays in notebook applications. The circuit is designed to operate from a single-cell Li-Ion battery and generates output voltages for the source driver VO1 of 10 V, for the gate driver VO2 of -5 V and VO3 of 23 V and a VCOM voltage of VO1/2.

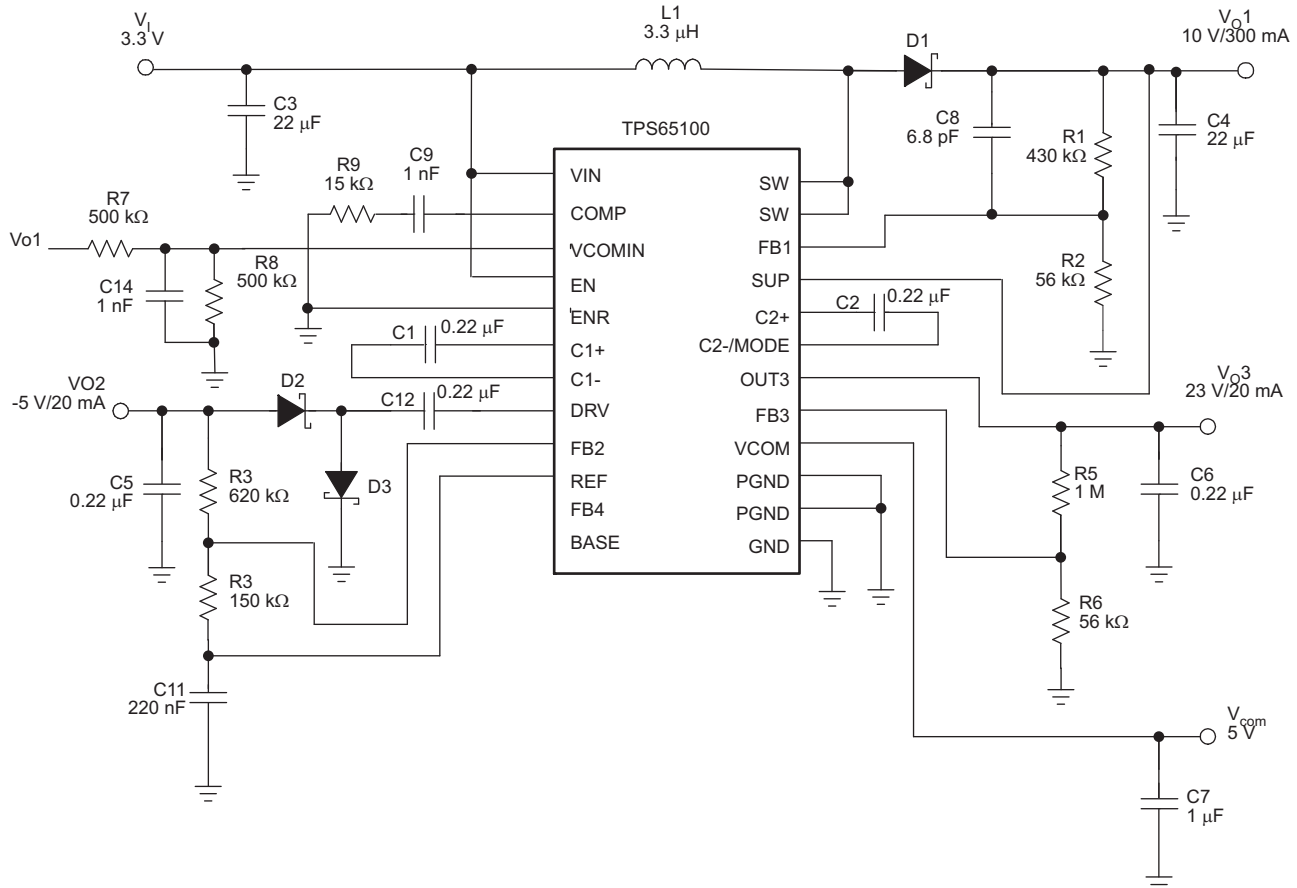

Copyright © 2016, Texas Instruments Incorporated

**Figure 19. Typical Application, Notebook Supply Diagram**

## System Examples (continued)

### 9.3.2 Monitor Supply

Figure 20 shows a typical application circuit suitable to supply (TFT) LCD displays in monitor applications. The circuit is designed to operate by a 5-V power rail and generates output voltages for the source driver VO1 of 13.5 V, for the gate driver VO2 of -7 V and VO3 of 23 V and a VCOM voltage of VO1/2. Additionally monitor applications also require a supply voltage for the digital part that is provided from VO4 of 3.3 V.

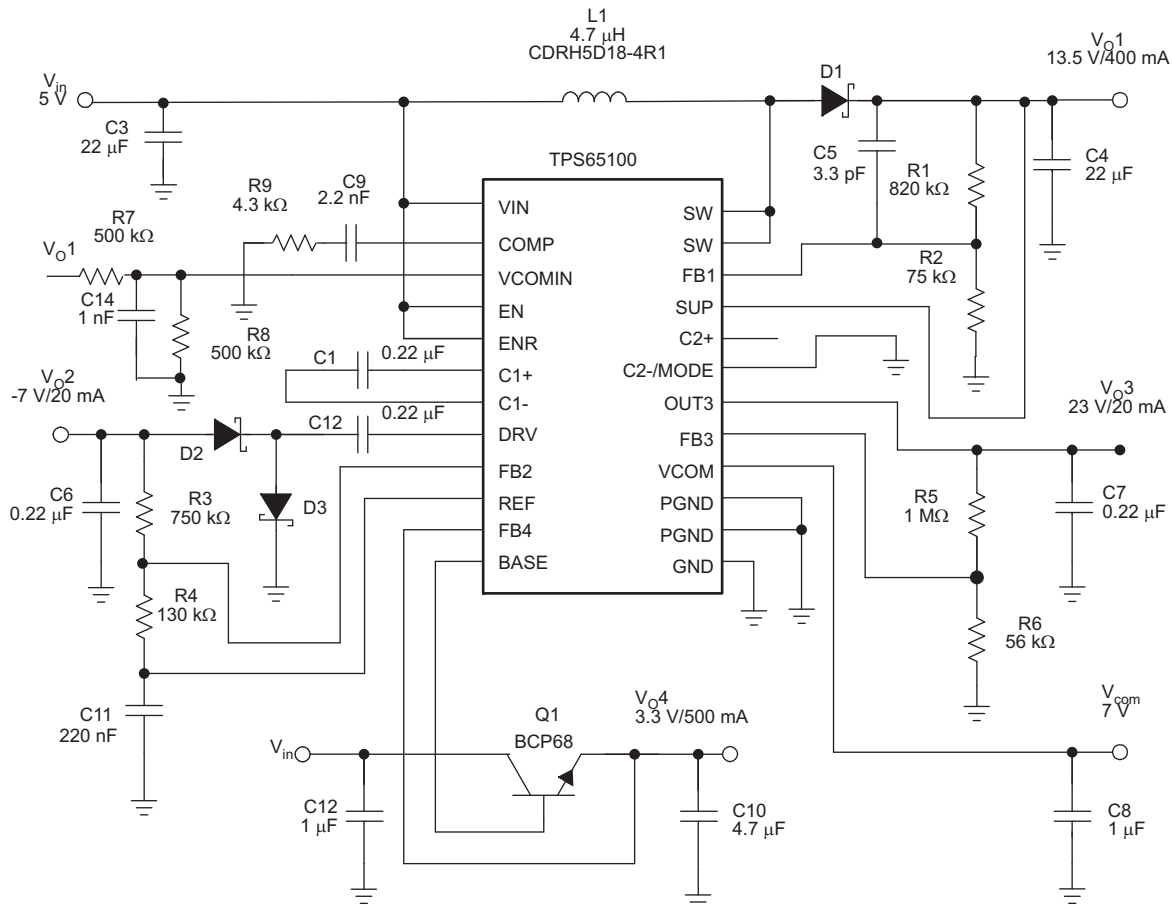

Copyright © 2016, Texas Instruments Incorporated

Figure 20. Typical Application, Monitor Supply Diagram

## 10 Power Supply Recommendations

The TPS6510x devices are designed to operate from an input voltage supply range from 2.7 V to 5.8 V. This input supply must be well regulated.

## 11 Layout

### 11.1 Layout Guidelines

For all switching power supplies, the layout is an important step in the design, especially at high-peak currents and switching frequencies. If the layout is not carefully designed, the regulator might show stability and EMI problems. Therefore, the traces carrying high-switching currents should be routed first using wide and short traces. The input filter capacitor should be placed as close as possible to the input pin VIN of the IC. TI recommends the following PCB layout guidelines for the TPS6510x devices:

1. Connect PGND and AGND together on the same ground plane
2. Connect all capacitor grounds and PGND together on a common ground plane.
3. Place the input capacitor as close as possible to the input pin of the IC.
4. Place the rectifier diode as close as possible to the IC
5. Route first the traces carrying high-switching current with wide and short traces
6. Isolate analog signal paths from power paths.
7. If vias are necessary, try to use more than one in parallel to decrease parasitics, especially for power traces.
8. Solder the thermal pad to the PCB for good thermal performance.

### 11.2 Layout Example

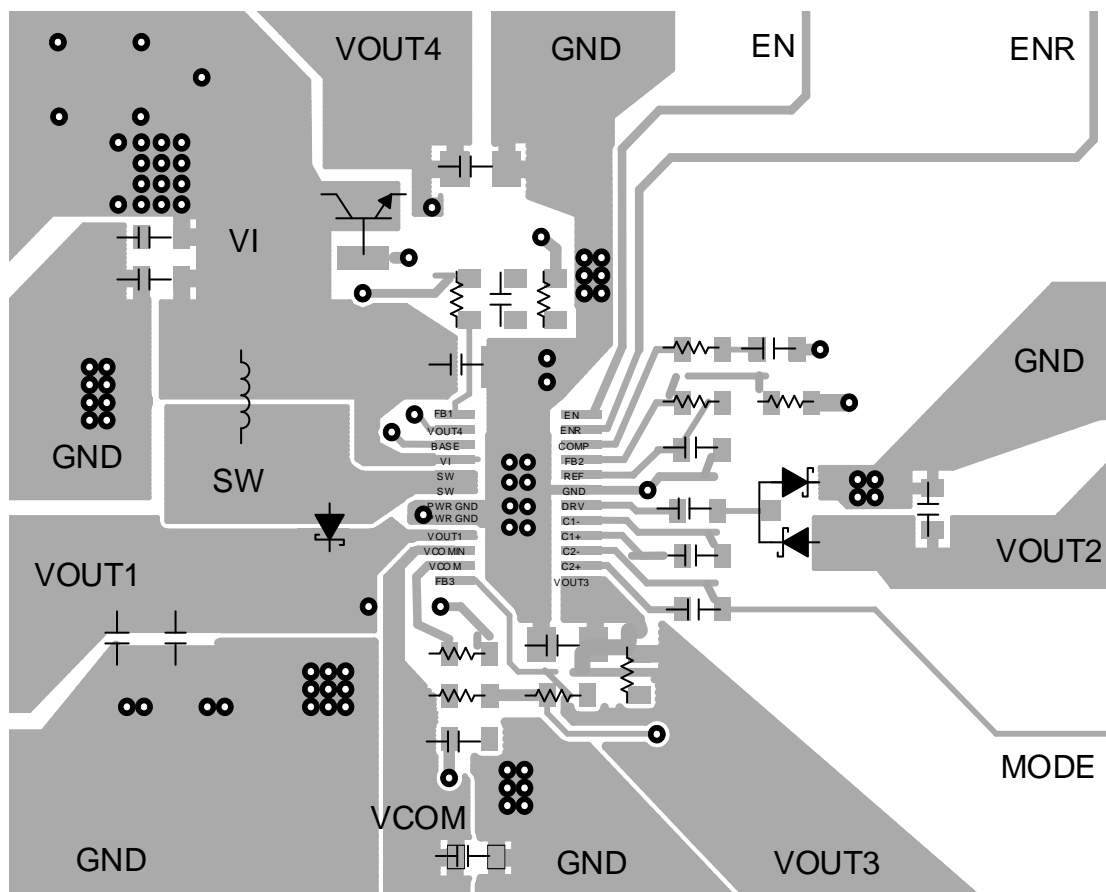

**Figure 21. TPS6510x Layout Example**

### 11.3 Thermal Performance

An influential component of thermal performance of a package is board design. To take full advantage of the heat dissipation abilities of the PowerPAD or VQFN package with exposed thermal die, a board that acts similar to a heat sink and allows the use of an exposed (and solderable) deep downset pad should be used. For further information, see the Texas Instruments application notes [PowerPAD Thermally Enhanced Package](#) and [PowerPAD Made Easy](#). For the VQFN package, see the [QFN/SON PCB Attachment](#) application report. Especially for the VQFN package it is required to solder down the Thermal Pad to achieve the required thermal resistance.

## 12 Device and Documentation Support

### 12.1 Device Support

#### 12.1.1 Third-Party Products Disclaimer

TI'S PUBLICATION OF INFORMATION REGARDING THIRD-PARTY PRODUCTS OR SERVICES DOES NOT CONSTITUTE AN ENDORSEMENT REGARDING THE SUITABILITY OF SUCH PRODUCTS OR SERVICES OR A WARRANTY, REPRESENTATION OR ENDORSEMENT OF SUCH PRODUCTS OR SERVICES, EITHER ALONE OR IN COMBINATION WITH ANY TI PRODUCT OR SERVICE.

### 12.2 Documentation Support

#### 12.2.1 Related Documentation

For related documentation see the following:

- [PowerPAD Thermally Enhanced Package](#) (SLMA002)
- [QFN/SON PCB Attachment](#) (SLUA271)
- [PowerPAD Made Easy](#) (SLMA004)
- [How to Compensate the TPS6510x](#) (SLVA813)
- [Simplifying Stability Checks](#) (SLVA381)

### 12.3 Related Links

The table below lists quick access links. Categories include technical documents, support and community resources, tools and software, and quick access to sample or buy.

**Table 7. Related Links**

PARTS	PRODUCT FOLDER	SAMPLE & BUY	TECHNICAL DOCUMENTS	TOOLS & SOFTWARE	SUPPORT & COMMUNITY
TPS65100	<a href="#">Click here</a>	<a href="#">Click here</a>	<a href="#">Click here</a>	<a href="#">Click here</a>	<a href="#">Click here</a>
TPS65101	<a href="#">Click here</a>	<a href="#">Click here</a>	<a href="#">Click here</a>	<a href="#">Click here</a>	<a href="#">Click here</a>
TPS65105	<a href="#">Click here</a>	<a href="#">Click here</a>	<a href="#">Click here</a>	<a href="#">Click here</a>	<a href="#">Click here</a>

### 12.4 Receiving Notification of Documentation Updates

To receive notification of documentation updates, navigate to the device product folder on ti.com. In the upper right corner, click on *Alert me* to register and receive a weekly digest of any product information that has changed. For change details, review the revision history included in any revised document.

### 12.5 Community Resource

The following links connect to TI community resources. Linked contents are provided "AS IS" by the respective contributors. They do not constitute TI specifications and do not necessarily reflect TI's views; see TI's [Terms of Use](#).

**TI E2E™ Online Community** *TI's Engineer-to-Engineer (E2E) Community*. Created to foster collaboration among engineers. At [e2e.ti.com](http://e2e.ti.com), you can ask questions, share knowledge, explore ideas and help solve problems with fellow engineers.

**Design Support** *TI's Design Support* Quickly find helpful E2E forums along with design support tools and contact information for technical support.

### 12.6 Trademarks

PowerPAD, E2E are trademarks of Texas Instruments.  
All other trademarks are the property of their respective owners.

## 12.7 Electrostatic Discharge Caution



These devices have limited built-in ESD protection. The leads should be shorted together or the device placed in conductive foam during storage or handling to prevent electrostatic damage to the MOS gates.

## 12.8 Glossary

[SLYZ022](#) — *TI Glossary*.

This glossary lists and explains terms, acronyms, and definitions.

## 13 Mechanical, Packaging, and Orderable Information

The following pages include mechanical, packaging, and orderable information. This information is the most current data available for the designated devices. This data is subject to change without notice and revision of this document. For browser-based versions of this data sheet, refer to the left-hand navigation.

**PACKAGING INFORMATION**

Orderable Device	Status (1)	Package Type	Package Drawing	Pins	Package Qty	Eco Plan (2)	Lead finish/ Ball material (6)	MSL Peak Temp (3)	Op Temp (°C)	Device Marking (4/5)	Samples
TPS65100PWP	ACTIVE	HTSSOP	PWP	24	60	RoHS & Green	NIPDAU	Level-2-260C-1 YEAR	-40 to 85	TPS65100	<a href="#">Samples</a>
TPS65100PWPR	ACTIVE	HTSSOP	PWP	24	2000	RoHS & Green	NIPDAU	Level-2-260C-1 YEAR	-40 to 85	TPS65100	<a href="#">Samples</a>
TPS65100RGER	ACTIVE	VQFN	RGE	24	3000	RoHS & Green	NIPDAU	Level-2-260C-1 YEAR	-40 to 85	TPS 65100	<a href="#">Samples</a>
TPS65101PWP	ACTIVE	HTSSOP	PWP	24	60	RoHS & Green	NIPDAU	Level-2-260C-1 YEAR	-40 to 85	TPS65101	<a href="#">Samples</a>
TPS65101PWPR	ACTIVE	HTSSOP	PWP	24	2000	RoHS & Green	NIPDAU	Level-2-260C-1 YEAR	-40 to 85	TPS65101	<a href="#">Samples</a>
TPS65101RGER	ACTIVE	VQFN	RGE	24	3000	RoHS & Green	NIPDAU	Level-2-260C-1 YEAR	-40 to 85	TPS 65101	<a href="#">Samples</a>
TPS65105PWP	ACTIVE	HTSSOP	PWP	24	60	RoHS & Green	NIPDAU	Level-2-260C-1 YEAR	-40 to 85	TPS65105	<a href="#">Samples</a>
TPS65105PWPR	ACTIVE	HTSSOP	PWP	24	2000	RoHS & Green	NIPDAU	Level-2-260C-1 YEAR	-40 to 85	TPS65105	<a href="#">Samples</a>
TPS65105RGER	ACTIVE	VQFN	RGE	24	3000	RoHS & Green	NIPDAU	Level-2-260C-1 YEAR	-40 to 85	TPS 65105	<a href="#">Samples</a>
TPS65105RGERG4	ACTIVE	VQFN	RGE	24	3000	RoHS & Green	NIPDAU	Level-2-260C-1 YEAR	-40 to 85	TPS 65105	<a href="#">Samples</a>

(1) The marketing status values are defined as follows:

**ACTIVE:** Product device recommended for new designs.

**LIFEBUY:** TI has announced that the device will be discontinued, and a lifetime-buy period is in effect.

**NRND:** Not recommended for new designs. Device is in production to support existing customers, but TI does not recommend using this part in a new design.

**PREVIEW:** Device has been announced but is not in production. Samples may or may not be available.

**OBSELETE:** TI has discontinued the production of the device.

(2) **RoHS:** TI defines "RoHS" to mean semiconductor products that are compliant with the current EU RoHS requirements for all 10 RoHS substances, including the requirement that RoHS substance do not exceed 0.1% by weight in homogeneous materials. Where designed to be soldered at high temperatures, "RoHS" products are suitable for use in specified lead-free processes. TI may reference these types of products as "Pb-Free".

**RoHS Exempt:** TI defines "RoHS Exempt" to mean products that contain lead but are compliant with EU RoHS pursuant to a specific EU RoHS exemption.

**Green:** TI defines "Green" to mean the content of Chlorine (Cl) and Bromine (Br) based flame retardants meet JS709B low halogen requirements of <=1000ppm threshold. Antimony trioxide based flame retardants must also meet the <=1000ppm threshold requirement.

(3) MSL, Peak Temp. - The Moisture Sensitivity Level rating according to the JEDEC industry standard classifications, and peak solder temperature.

- (4) There may be additional marking, which relates to the logo, the lot trace code information, or the environmental category on the device.
- (5) Multiple Device Markings will be inside parentheses. Only one Device Marking contained in parentheses and separated by a "~" will appear on a device. If a line is indented then it is a continuation of the previous line and the two combined represent the entire Device Marking for that device.
- (6) Lead finish/Ball material - Orderable Devices may have multiple material finish options. Finish options are separated by a vertical ruled line. Lead finish/Ball material values may wrap to two lines if the finish value exceeds the maximum column width.

**Important Information and Disclaimer:**The information provided on this page represents TI's knowledge and belief as of the date that it is provided. TI bases its knowledge and belief on information provided by third parties, and makes no representation or warranty as to the accuracy of such information. Efforts are underway to better integrate information from third parties. TI has taken and continues to take reasonable steps to provide representative and accurate information but may not have conducted destructive testing or chemical analysis on incoming materials and chemicals. TI and TI suppliers consider certain information to be proprietary, and thus CAS numbers and other limited information may not be available for release.

In no event shall TI's liability arising out of such information exceed the total purchase price of the TI part(s) at issue in this document sold by TI to Customer on an annual basis.

**OTHER QUALIFIED VERSIONS OF TPS65100 :**

- Automotive : [TPS65100-Q1](#)

NOTE: Qualified Version Definitions:

- Automotive - Q100 devices qualified for high-reliability automotive applications targeting zero defects

**TAPE AND REEL INFORMATION**

**QUADRANT ASSIGNMENTS FOR PIN 1 ORIENTATION IN TAPE**



\*All dimensions are nominal

Device	Package Type	Package Drawing	Pins	SPQ	Reel Diameter (mm)	Reel Width W1 (mm)	A0 (mm)	B0 (mm)	K0 (mm)	P1 (mm)	W (mm)	Pin1 Quadrant
TPS65100PWPR	HTSSOP	PWP	24	2000	330.0	16.4	6.95	8.3	1.6	8.0	16.0	Q1
TPS65100RGER	VQFN	RGE	24	3000	330.0	12.4	4.25	4.25	1.15	8.0	12.0	Q2
TPS65101PWPR	HTSSOP	PWP	24	2000	330.0	16.4	6.95	8.3	1.6	8.0	16.0	Q1
TPS65101RGER	VQFN	RGE	24	3000	330.0	12.4	4.25	4.25	1.15	8.0	12.0	Q2
TPS65105PWPR	HTSSOP	PWP	24	2000	330.0	16.4	6.95	8.3	1.6	8.0	16.0	Q1
TPS65105RGER	VQFN	RGE	24	3000	330.0	12.4	4.25	4.25	1.15	8.0	12.0	Q2

**TAPE AND REEL BOX DIMENSIONS**

\*All dimensions are nominal

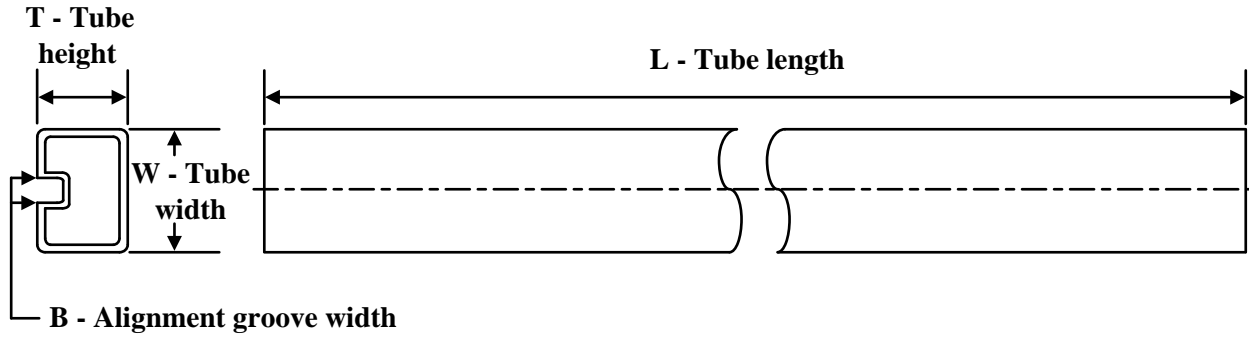
Device	Package Type	Package Drawing	Pins	SPQ	Length (mm)	Width (mm)	Height (mm)
TPS65100PWPR	HTSSOP	PWP	24	2000	350.0	350.0	43.0
TPS65100RGER	VQFN	RGE	24	3000	356.0	356.0	35.0
TPS65101PWPR	HTSSOP	PWP	24	2000	350.0	350.0	43.0
TPS65101RGER	VQFN	RGE	24	3000	356.0	356.0	35.0
TPS65105PWPR	HTSSOP	PWP	24	2000	350.0	350.0	43.0
TPS65105RGER	VQFN	RGE	24	3000	356.0	356.0	35.0

**TUBE**

\*All dimensions are nominal

Device	Package Name	Package Type	Pins	SPQ	L (mm)	W (mm)	T (μm)	B (mm)
TPS65100PWP	PWP	HTSSOP	24	60	530	10.2	3600	3.5
TPS65101PWP	PWP	HTSSOP	24	60	530	10.2	3600	3.5
TPS65105PWP	PWP	HTSSOP	24	60	530	10.2	3600	3.5

## GENERIC PACKAGE VIEW

**PWP 24**

**PowerPAD™ TSSOP - 1.2 mm max height**

4.4 x 7.6, 0.65 mm pitch

PLASTIC SMALL OUTLINE

This image is a representation of the package family, actual package may vary.  
Refer to the product data sheet for package details.

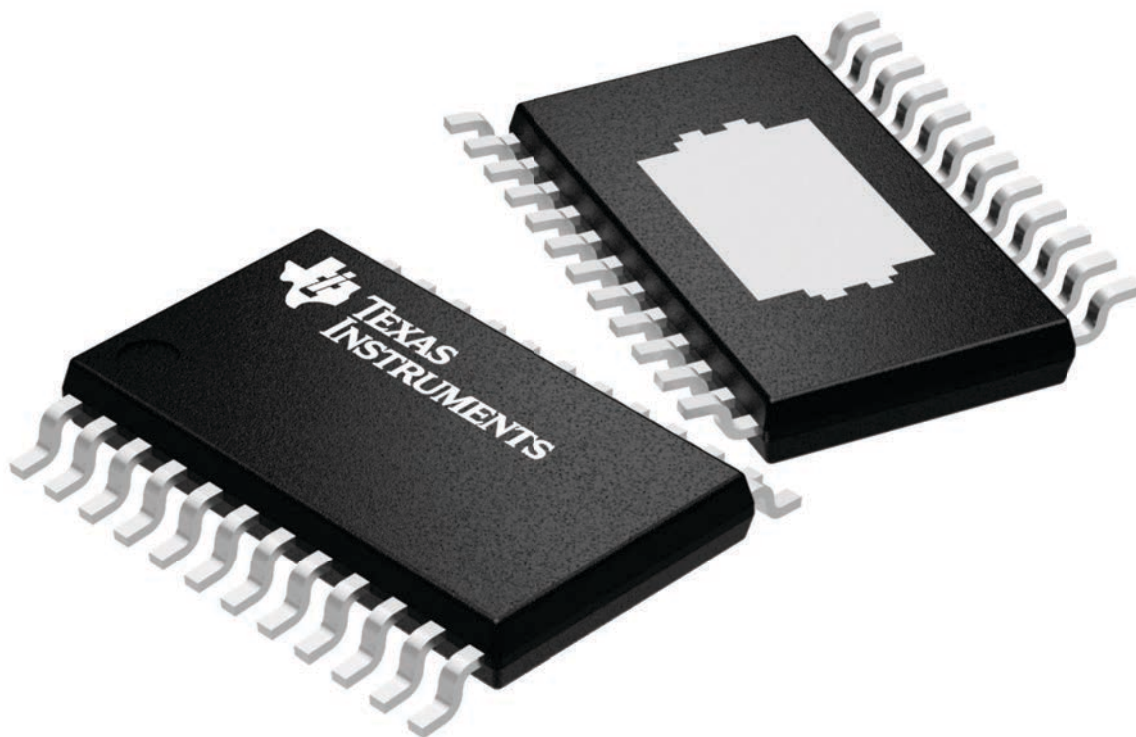

4224742/B

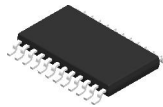

# PACKAGE OUTLINE

## PWP0024B

## PowerPAD™ TSSOP - 1.2 mm max height

PLASTIC SMALL OUTLINE

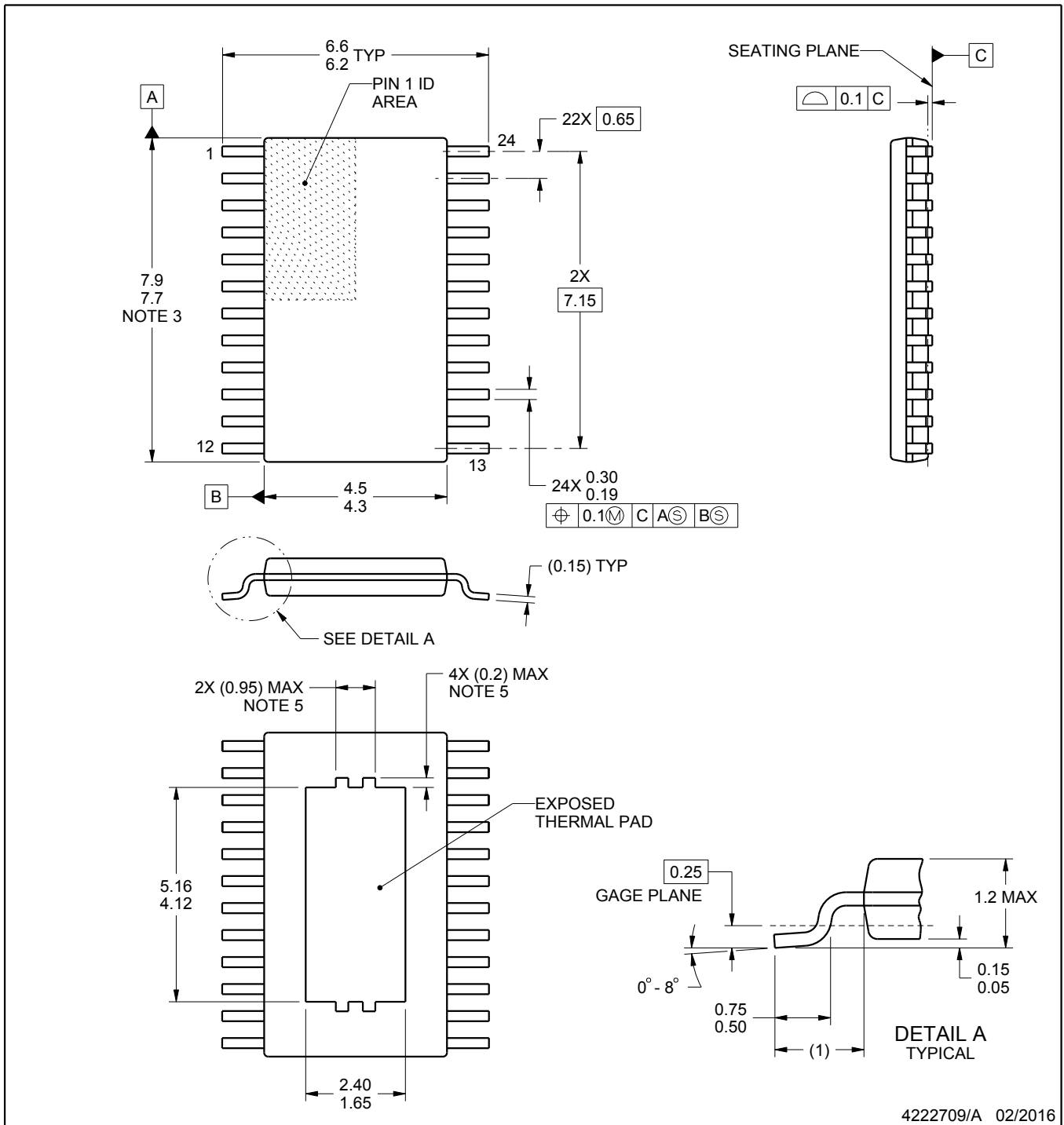

4222709/A 02/2016

### NOTES:

PowerPAD is a trademark of Texas Instruments.

1. All linear dimensions are in millimeters. Any dimensions in parenthesis are for reference only. Dimensioning and tolerancing per ASME Y14.5M.
2. This drawing is subject to change without notice.
3. This dimension does not include mold flash, protrusions, or gate burrs. Mold flash, protrusions, or gate burrs shall not exceed 0.15 mm per side.
4. Reference JEDEC registration MO-153.
5. Features may not be present and may vary.

# EXAMPLE BOARD LAYOUT

PWP0024B

PowerPAD™ TSSOP - 1.2 mm max height

PLASTIC SMALL OUTLINE

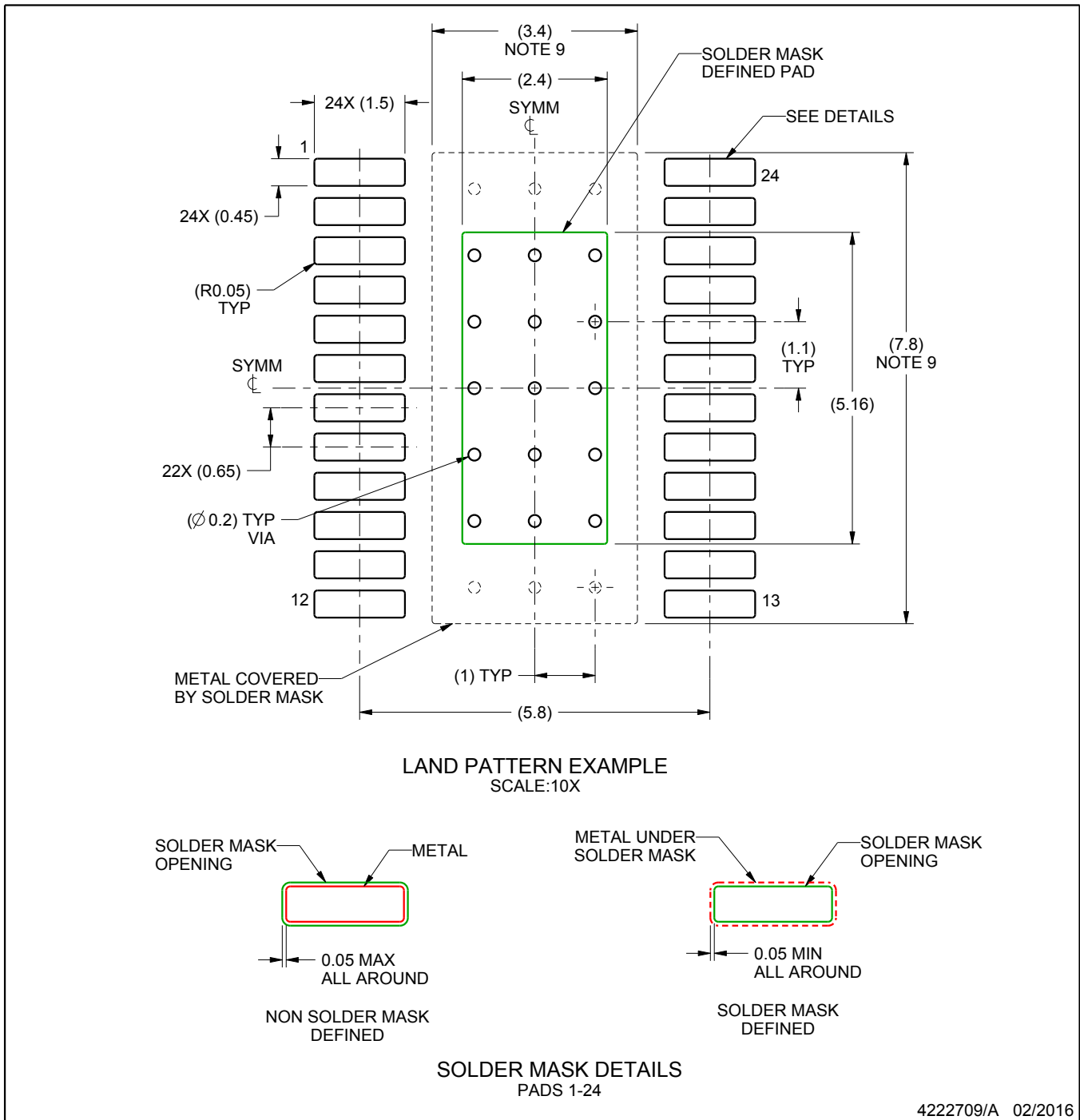

NOTES: (continued)

6. Publication IPC-7351 may have alternate designs.
7. Solder mask tolerances between and around signal pads can vary based on board fabrication site.
8. This package is designed to be soldered to a thermal pad on the board. For more information, see Texas Instruments literature numbers SLMA002 ([www.ti.com/lit/slma002](http://www.ti.com/lit/slma002)) and SLMA004 ([www.ti.com/lit/slma004](http://www.ti.com/lit/slma004)).
9. Size of metal pad may vary due to creepage requirement.

# EXAMPLE STENCIL DESIGN

PWP0024B

PowerPAD™ TSSOP - 1.2 mm max height

PLASTIC SMALL OUTLINE

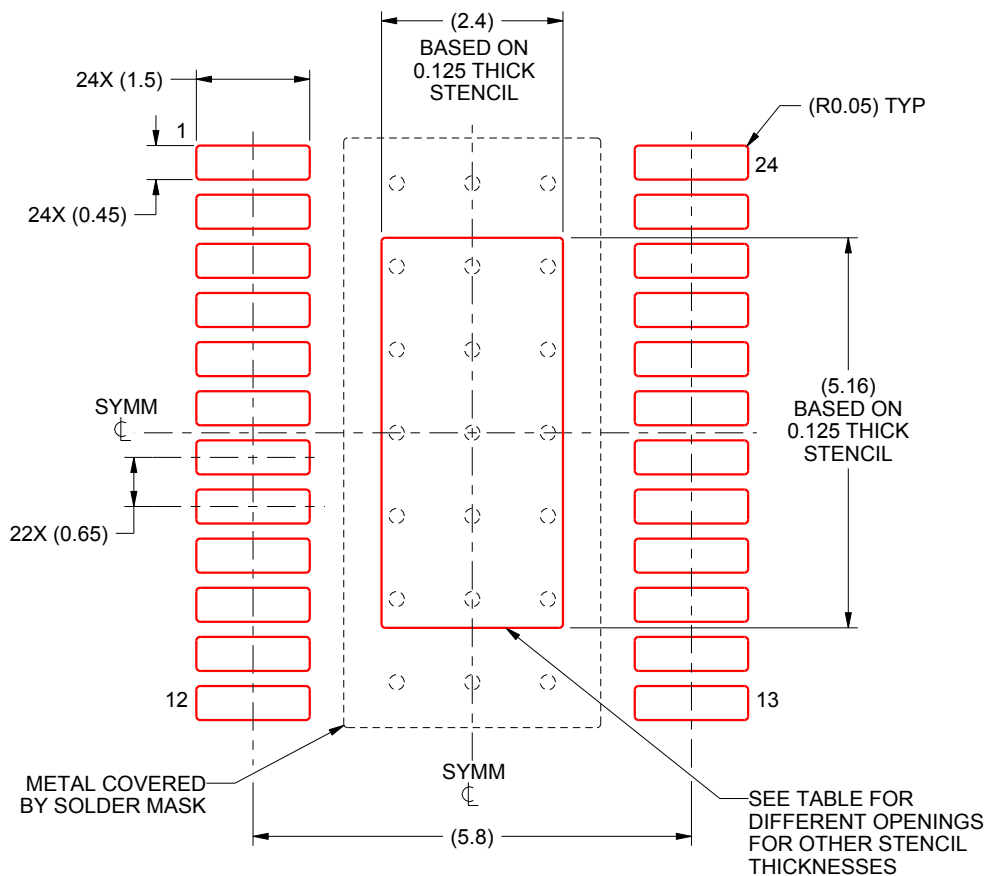

**SOLDER PASTE EXAMPLE**  
 EXPOSED PAD  
 100% PRINTED SOLDER COVERAGE BY AREA  
 SCALE:10X

STENCIL THICKNESS	SOLDER STENCIL OPENING
0.1	2.68 X 5.77
0.125	2.4 X 5.16 (SHOWN)
0.15	2.19 X 4.71
0.175	2.03 X 4.36

4222709/A 02/2016

NOTES: (continued)

10. Laser cutting apertures with trapezoidal walls and rounded corners may offer better paste release. IPC-7525 may have alternate design recommendations.
11. Board assembly site may have different recommendations for stencil design.

**RGE 24**

**GENERIC PACKAGE VIEW**

**VQFN - 1 mm max height**

PLASTIC QUAD FLATPACK - NO LEAD

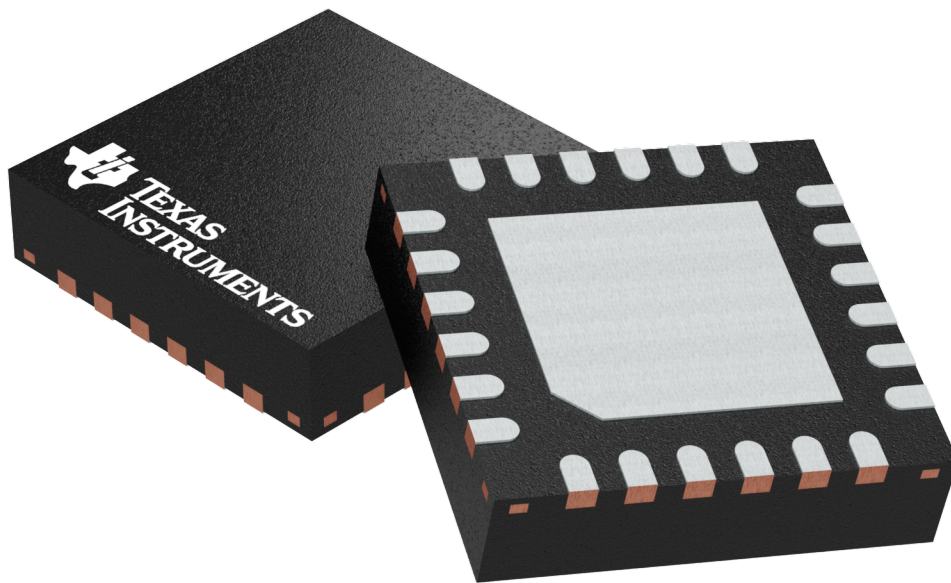

Images above are just a representation of the package family, actual package may vary.  
Refer to the product data sheet for package details.

4204104/H

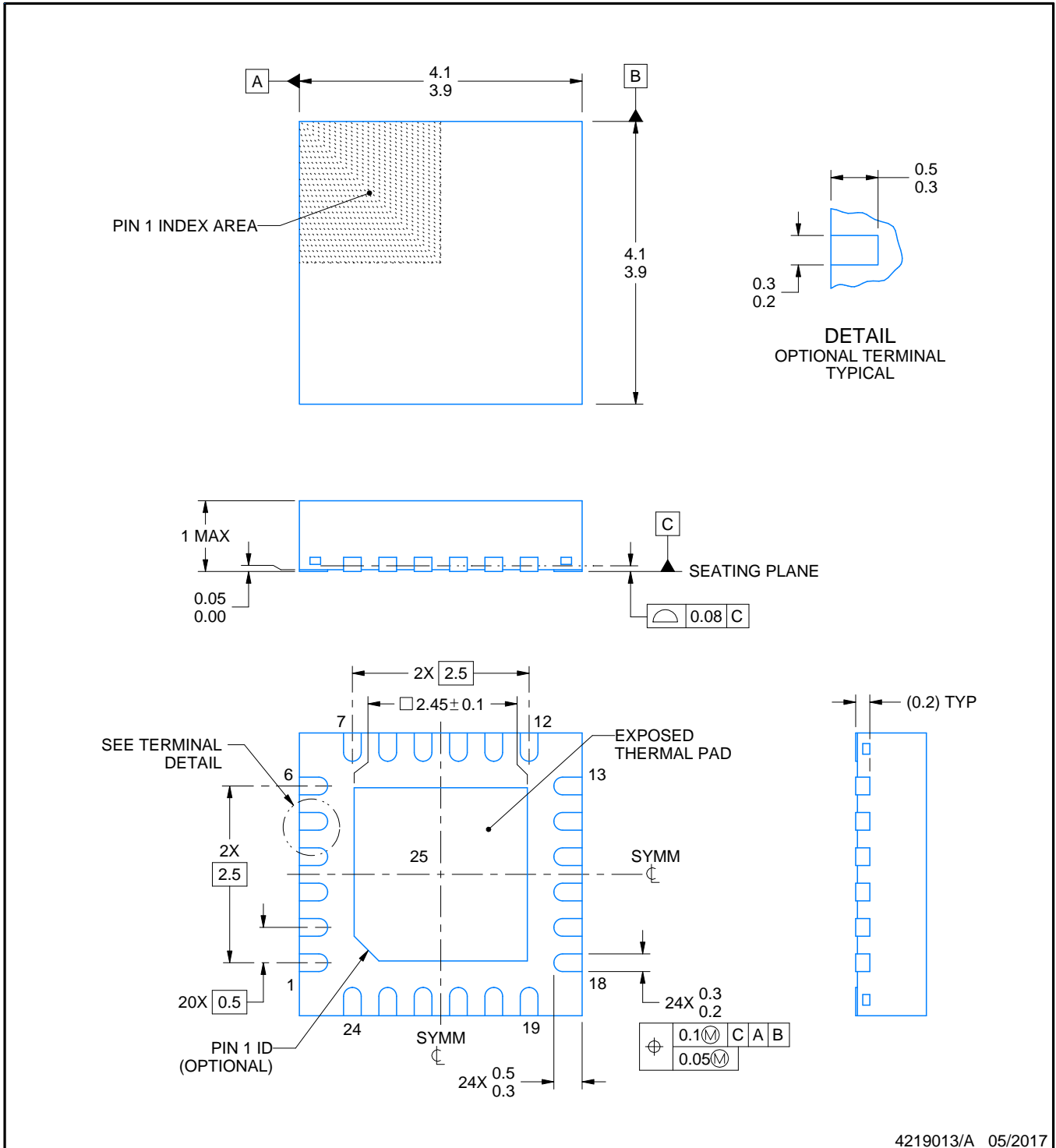
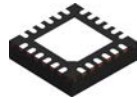

4219013/A 05/2017

NOTES:

1. All linear dimensions are in millimeters. Any dimensions in parenthesis are for reference only. Dimensioning and tolerancing per ASME Y14.5M.
2. This drawing is subject to change without notice.
3. The package thermal pad must be soldered to the printed circuit board for thermal and mechanical performance.

# EXAMPLE BOARD LAYOUT

RGE0024B

VQFN - 1 mm max height

PLASTIC QUAD FLATPACK - NO LEAD

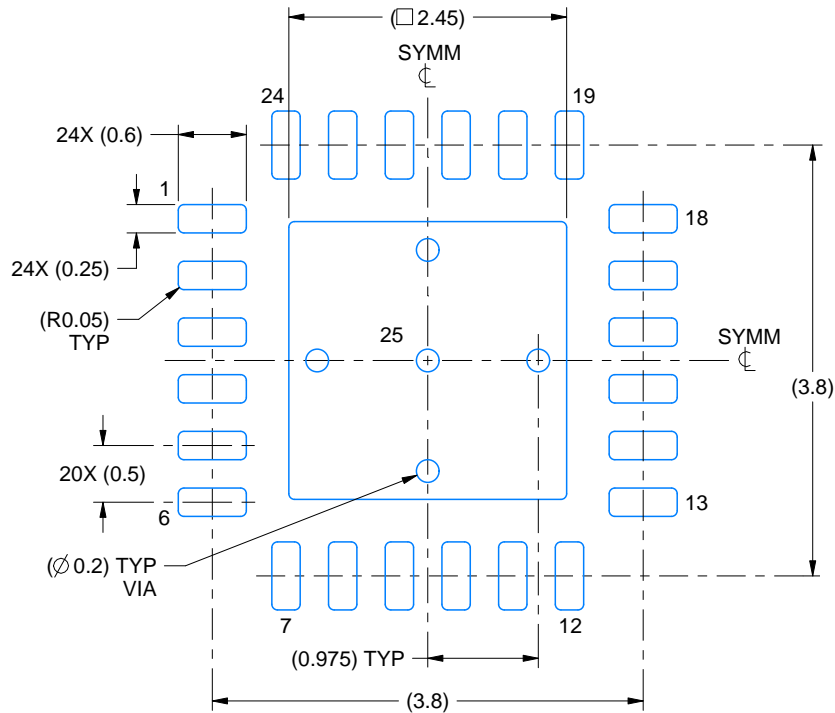

LAND PATTERN EXAMPLE  
EXPOSED METAL SHOWN  
SCALE:15X

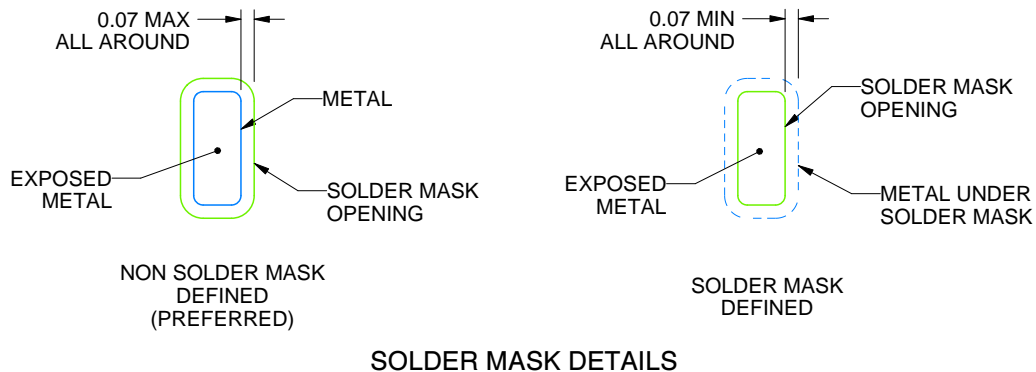

SOLDER MASK DETAILS

4219013/A 05/2017

NOTES: (continued)

- This package is designed to be soldered to a thermal pad on the board. For more information, see Texas Instruments literature number SLUA271 ([www.ti.com/lit/slua271](http://www.ti.com/lit/slua271)).
- Vias are optional depending on application, refer to device data sheet. If any vias are implemented, refer to their locations shown on this view. It is recommended that vias under paste be filled, plugged or tented.

# EXAMPLE STENCIL DESIGN

RGE0024B

VQFN - 1 mm max height

PLASTIC QUAD FLATPACK - NO LEAD

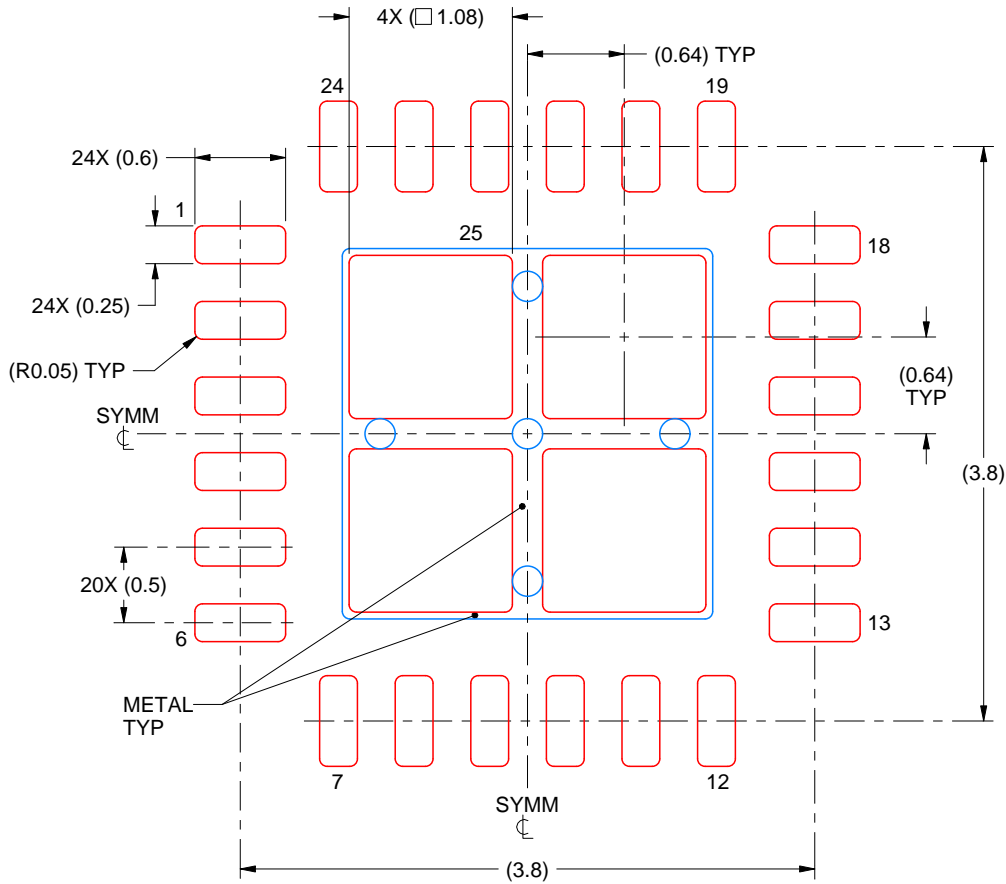

**SOLDER PASTE EXAMPLE**  
 BASED ON 0.125 mm THICK STENCIL

EXPOSED PAD 25  
 78% PRINTED SOLDER COVERAGE BY AREA UNDER PACKAGE  
 SCALE:20X

4219013/A 05/2017

NOTES: (continued)

6. Laser cutting apertures with trapezoidal walls and rounded corners may offer better paste release. IPC-7525 may have alternate design recommendations.

## IMPORTANT NOTICE AND DISCLAIMER

TI PROVIDES TECHNICAL AND RELIABILITY DATA (INCLUDING DATA SHEETS), DESIGN RESOURCES (INCLUDING REFERENCE DESIGNS), APPLICATION OR OTHER DESIGN ADVICE, WEB TOOLS, SAFETY INFORMATION, AND OTHER RESOURCES "AS IS" AND WITH ALL FAULTS, AND DISCLAIMS ALL WARRANTIES, EXPRESS AND IMPLIED, INCLUDING WITHOUT LIMITATION ANY IMPLIED WARRANTIES OF MERCHANTABILITY, FITNESS FOR A PARTICULAR PURPOSE OR NON-INFRINGEMENT OF THIRD PARTY INTELLECTUAL PROPERTY RIGHTS.

These resources are intended for skilled developers designing with TI products. You are solely responsible for (1) selecting the appropriate TI products for your application, (2) designing, validating and testing your application, and (3) ensuring your application meets applicable standards, and any other safety, security, regulatory or other requirements.

These resources are subject to change without notice. TI grants you permission to use these resources only for development of an application that uses the TI products described in the resource. Other reproduction and display of these resources is prohibited. No license is granted to any other TI intellectual property right or to any third party intellectual property right. TI disclaims responsibility for, and you will fully indemnify TI and its representatives against, any claims, damages, costs, losses, and liabilities arising out of your use of these resources.

TI's products are provided subject to [TI's Terms of Sale](#) or other applicable terms available either on [ti.com](https://www.ti.com) or provided in conjunction with such TI products. TI's provision of these resources does not expand or otherwise alter TI's applicable warranties or warranty disclaimers for TI products.

TI objects to and rejects any additional or different terms you may have proposed.

Mailing Address: Texas Instruments, Post Office Box 655303, Dallas, Texas 75265  
Copyright © 2023, Texas Instruments Incorporated

## Looking for pricing, stock, or lifecycle information?

Click below to explore more details on WIN SOURCE:

 [View TPS65100RGER](#) on WIN SOURCE

 [Texas Instruments](#) Information

## Optimize Your Supply Chain with WIN SOURCE Solutions

-  Global Sourcing Solution
-  Obsolete Management
-  Cost Control Management
-  Shortage Management
-  Alternative Solution
-  Excess Inventory Management