

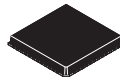

THE DATASHEET OF TPS65162RGZRG4





Compact LCD Bias IC With High Speed Amplifiers for TV-LCD Panels

 Check for Samples: [TPS65162](#)

FEATURES

- 8-V to 14.7-V Input Voltage Range
- 500 kHz / 750 kHz Fixed Switching Frequency
- Boost Output Voltage up to 19 V
 - 1%-Accurate Boost With 2.8-A Switch Current Overvoltage Protection
- Input-to-Output Isolation Switch for Vs Short-Circuit protection for Boost
- 2.5-A Step-Down Converter
- Regulated Positive Charge-Pump Driver VGH
- Regulated Negative Charge-Pump Driver VGL
- Gate Voltage Shaping for VGH
- Soft Start for all Converters
- Two Integrated High-Speed Opamps
 - 50-MHz, 3-dB Bandwidth
 - Slew Rate 55 V / μ s
 - 215-mA Short-Circuit Current
- 48 Pin 7x7 mm QFN Package

APPLICATIONS

- LCD TV
- LCD Monitor

DESCRIPTION

The TPS65162 is a compact LCD bias IC with two high-speed operational amplifiers for the V_{com} supply. The high current capability of the device is ideal for large LCD-monitor and LCD-TV applications.

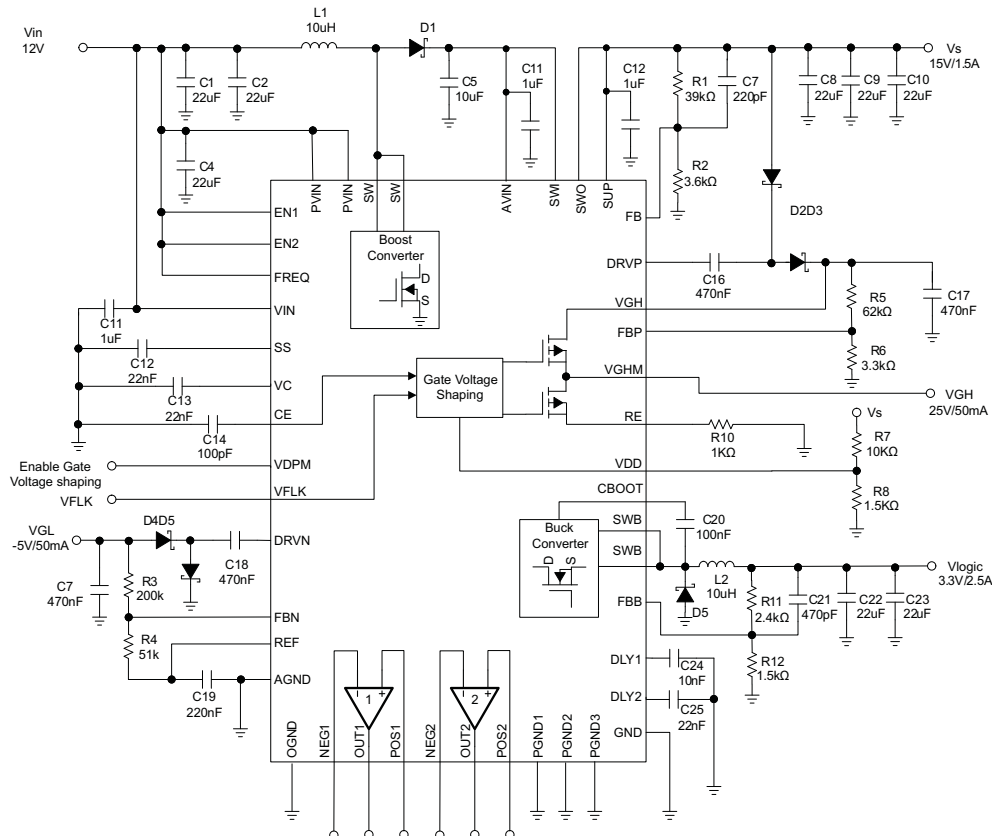

Please be aware that an important notice concerning availability, standard warranty, and use in critical applications of Texas Instruments semiconductor products and disclaimers thereto appears at the end of this data sheet.

PowerPAD is a trademark of Texas Instruments.

PRODUCTION DATA information is current as of publication date. Products conform to specifications per the terms of the Texas Instruments standard warranty. Production processing does not necessarily include testing of all parameters.



These devices have limited built-in ESD protection. The leads should be shorted together or the device placed in conductive foam during storage or handling to prevent electrostatic damage to the MOS gates.

DESCRIPTION (CONTINUED)

The TPS65162 generates all four voltage rails for a TFT LCD (V_s , V_{logic} , V_{GH} and V_{GL}) and includes two op-amps to generate the V_{COM} supply rail. An input-to-output isolation switch is integrated into the device, providing short-circuit protection for the boost converter. A current-limit function is implemented in the input-to-output isolation switch to allow soft turn-on during start-up. The device also features gate voltage shaping for improved TFT-LCD picture quality. The device consists of a boost converter to provide the source voltage V_s , and a step-down converter to provide the logic voltage for the system. A positive and a negative charge-pump driver provide adjustable regulated output voltages V_{GH} and V_{GL} to bias the TFT. Both boost and buck converter, as well as the charge-pump drivers, operate with a fixed switching frequency of 500 kHz or 750 kHz, selectable by the $FREQ$ pin. The device includes adjustable power-on sequencing. The safety features of the device are overvoltage protection for boost converter, short-circuit protection for V_s , V_{logic} and V_{GH} , and thermal shutdown.

ORDERING INFORMATION⁽¹⁾

T_A	ORDERING	QFN PACKAGE	PACKAGE MARKING
-40°C to 85°C	TPS65162RGZR	48 pin QFN	TPS65162

(1) The RGZ package is available taped and reeled and shipped in quantities of 2500 devices per reel.

ABSOLUTE MAXIMUM RATINGS

over operating free-air temperature range (unless otherwise noted)⁽¹⁾

		VALUE	UNIT
Input voltage range V_{IN} , PV_{IN} ⁽²⁾		-0.3 to 16.8	V
Voltage range at $EN1$, $EN2$, $FREQ$, $VDPM$, $VFLK$		-0.3 to 16.8	V
V_I	Voltage on pin		
	AVIN, SUP	25	V
	VGH, VGHM, RE	35	V
	SW, SWI, SWO	25	V
	SWB	20	V
Continuous total power dissipation		See Dissipation Rating Table	
T_J	Operating junction temperature range	-40 to 150	°C
T_A	Operating ambient temperature range	-65 to 85	°C
T_{stg}	Storage temperature range	-65 to 150	°C

(1) Stresses beyond those listed under *absolute maximum ratings* may cause permanent damage to the device. These are stress ratings only, and functional operation of the device at these or any other conditions beyond those indicated under *recommended operating conditions* is not implied. Exposure to absolute-maximum-rated conditions for extended periods may affect device reliability.

(2) All voltage values are with respect to network ground terminal.

DISSIPATION RATINGS⁽¹⁾

PACKAGE	$R_{\theta JA}$	$T_A \leq 25^\circ\text{C}$ POWER RATING	$T_A = 70^\circ\text{C}$ POWER RATING	$T_A = 85^\circ\text{C}$ POWER RATING
48 pin QFN	30°C/W	3.33 W	1.83 W	1.33 W

(1) Exposed thermal die is soldered to the PCB using thermal vias. Refer to Texas Instruments Application report (SLUA271) QFN/SON PCB Attachment.

RECOMMENDED OPERATING CONDITIONS

		MIN	TYP	MAX	UNIT
V_{IN} , PV_{IN}	Input voltage range	8	14.7		V
T_A	Operating ambient temperature	-40		85	°C
T_J	Operating junction temperature	-40		125	°C

ELECTRICAL CHARACTERISTICS

$V_{IN} = 12\text{ V}$, $EN1 = EN2 = \text{FREQ} = \text{high}$, $V_S = 15\text{ V}$, $V_{logic} = 3.3\text{ V}$, $T_A = -40^\circ\text{C}$ to 85°C , typical values are at $T_A = 25^\circ\text{C}$ (unless otherwise noted)

PARAMETER		TEST CONDITIONS	MIN	TYP	MAX	UNIT
SUPPLY CURRENT						
V_I	Input voltage range		8		14.7	V
I_{SD}	Shutdown current into VIN	$EN1 = EN2 = \text{GND}$		0.03	1	μA
	Shutdown current into PVIN	$EN1 = EN2 = \text{GND}$		0.01	1	
I_{QIN}	Quiescent current into VIN			1.7	4	mA
I_{SUP}	Shutdown current into SUP	$EN1 = EN2 = \text{GND}$		0.01	1	μA
I_{AVIN}	Shutdown current into AVIN	$EN1 = EN2 = \text{GND}$		50	220	μA
	Quiescent current into AVIN			8	10	
V_{UVLO}	Undervoltage lockout threshold	V_{IN} falling		7.6	7.95	V
V_{REF}	Reference voltage		1.253	1.265	1.277	V
	Thermal shutdown	Temperature rising		160		$^\circ\text{C}$
	Thermal shutdown hysteresis			10		$^\circ\text{C}$
LOGIC SIGNALS EN1, EN2, FREQ, VFLK, VDPM						
V_{IH}	High level input voltage EN1, EN2, VDPM, FREQ		2.0			V
V_{IL}	Low level input voltage EN1, EN2, VDPM, FREQ				0.8	V
V_{IH}	High level input voltage VFLK		1.7			V
V_{IL}	Low level input voltage VFLK				0.4	V
I_I	Input leakage current	$EN1 = EN2 = \text{FREQ} = \text{VFLK} = \text{VDPM} = \text{GND}$ or V_{IN}		0.01	0.1	μA
CONTROL AND SOFT START DLY1, DLY2, SS						
I_{chrg}	DLY1, DLY2 charge current	$V_{\text{threshold}} = 1.280\text{ V}$	3.5	5	6	μA
I_{SS}	SS charge current		6	9.2	12	
V_{thr}	Delay threshold			1.280		V
INTERNAL OSCILLATOR						
f_S	Oscillator frequency	FREQ = high	600	750	900	kHz
		FREQ = low	400	500	600	
BOOST CONVERTER (V_S)						
V_S	Output voltage range				19	V
V_{FB}	Feedback regulation voltage		1.255	1.268	1.280	V
I_{FB}	Feedback input bias current			10	100	nA
$r_{DS(on)}$	N-MOSFET on-resistance (Q1)	$V_S = 15\text{ V}$, $I_{(SW)} = 500\text{ mA}$		130	200	m Ω
	P-MOSFET on-resistance (Q2)	$V_S = 15\text{ V}$, $I_{(SW)} = 200\text{ mA}$		9	15	
I_{MAX}	Maximum P-MOSFET peak switch current				1	A
I_{LIM}	N-MOSFET switch current limit (Q1)		2.8	3.6	4.2	A
I_{lkg}	Switch leakage current	$V_{(SW)} = 15\text{ V}$		1	10	μA
$V_{(SW_ovp)}$	Switch overvoltage protection	V_{OUT} rising	19.5	20	21	V
	Line Regulation	$8\text{ V} \leq V_{IN} \leq 14\text{ V}$, $I_{OUT} = 2\text{ mA}$		0.007		%/V
	Load Regulation	$2\text{ mA} \leq I_{OUT} \leq 1.5\text{ A}$		0.03		%/A
ISOLATION SWITCH						
$r_{DS(on)}$	Isolation switch $r_{DS(on)}$	$I_{(SW)} = 1\text{ A}$, $V_S = 15\text{ V}$		200		m Ω
I	Switch current				2	A
I_{SC}	Short circuit current limit	$SWI = 12\text{ V}$, $SWO = 0\text{ V}$		350		mA

ELECTRICAL CHARACTERISTICS (continued)

$V_{IN} = 12\text{ V}$, $EN1 = EN2 = \text{FREQ} = \text{high}$, $V_S = 15\text{ V}$, $V_{logic} = 3.3\text{ V}$, $T_A = -40^\circ\text{C}$ to 85°C , typical values are at $T_A = 25^\circ\text{C}$ (unless otherwise noted)

PARAMETER		TEST CONDITIONS	MIN	TYP	MAX	UNIT
GATE VOLTAGE SHAPING VGHM						
V_{HVIN}	Input voltage				35	V
$r_{DS(on)}$	VGH to VGHM $r_{DS(on)}$ (Q1)	VFLK = high, I = 20 mA		10	15	Ω
	VGHM to RE $r_{DS(on)}$	VFLK = LOW, I = 20 mA		60	100	
I_{CE}	CE capacitor charge current	$V_{CE} = 1.265\text{ V}$	44	57	65	μA
V_{CE}	CE threshold voltage			1.284		V
G_{VDD}	VDD voltage gain	$V_{VDD} = 1\text{ V}$		5		V/V
STEP-DOWN CONVERTER (Vlogic)						
Vlogic	Output voltage range		1.5		5	V
V_{FB}	Feedback regulation voltage		1.240	1.265	1.290	V
I_{FB}	Feedback input bias current			10	100	nA
$r_{DS(on)}$	N-MOSFET on-resistance (Q1)	$PV_{IN} = 12\text{ V}$, $I_{(SW)} = 500\text{ mA}$		180	320	$\text{m}\Omega$
I_{LIM}	N-MOSFET switch current limit (Q1)		2.8	3.6	4.2	A
I_{ikg}	Switch leakage current	$V_{(SW)} = 0\text{ V}$		1	10	μA
	Line regulation	$8\text{ V} \leq V_{IN} \leq 14\text{ V}$, $I_{OUT} = 2\text{ mA}$		0.006		%/V
	Load regulation	$2\text{ mA} \leq I_{OUT} \leq 2.5\text{ A}$		0.06		%/A
NEGATIVE CHARGE PUMP VGL						
VGL	Output voltage range				-2	V
V_{FB}	Feedback regulation voltage		-48	0	48	mV
I_{FB}	Feedback input bias current			10	100	nA
$r_{DS(on)}$	Q4 P-Channel switch $r_{DS(on)}$	$I_O = 20\text{ mA}$		4	8	Ω
V_{DropN}	Current source voltage drop ⁽¹⁾	$I_{(DRVN)} = 50\text{ mA}$, $V_{(FBN)} = V_{(FBN_nominal)} - 5\%$		115	200	mV
		$I_{(DRVN)} = 100\text{ mA}$, $V_{(FBN)} = V_{(FBN_nominal)} - 5\%$		230	400	
	Load regulation	$1\text{ mA} \leq I_{OUT} \leq 100\text{ mA}$, $V_{GL} = -5\text{ V}$		0.01		%/mA
POSITIVE CHARGE PUMP OUTPUT VGH						
VGH	Output voltage range				34	V
V_{FB}	Feedback regulation voltage		1.228	1.265	1.302	V
I_{FB}	Feedback input bias current			10	100	nA
$r_{DS(on)}$	Q3 N-Channel switch $r_{DS(on)}$	$I_{OUT} = 20\text{ mA}$		1.0	1.8	Ω
V_{DropP}	Current source voltage drop ($V_{sup} - V_{DRP}$) ⁽¹⁾	$I_{DRP} = 50\text{ mA}$, $V_{FBP} = V_{FBP_nominal} - 5\%$		430	680	mV
		$I_{DRP} = 100\text{ mA}$, $V_{FBP} = V_{FBP_nominal} - 5\%$		950	1600	
	Load regulation	$1\text{ mA} \leq I_{OUT} \leq 50\text{ mA}$, $V_{GH} = 27\text{ V}$		0.073		%/mA
OPERATIONAL AMPLIFIERS 1, 2						
V_{os}	Input offset voltage	$V_{CM} = V_S/2$	-15		18	mV
I_B	Input bias current	$V_{CM} = V_S/2$		0.05	3	μA
V_{CM}	Common Mode Input Voltage Range		0		V_S	V
CMRR	Common Mode Rejection Ratio	$V_{CM} = 7.5\text{ V}$	70			dB
A_{VOL}	Open Loop Gain	$0.5\text{ V} \leq V_{OUT} \leq 14.5\text{ V}$, No load	50			dB
V_{OL}	Output Voltage Swing Low	$I_{OUT} = 10\text{ mA}$		60	200	mV
V_{OH}	Output Voltage Swing High	$I_{OUT} = 10\text{ mA}$	$V_S - 200$	$V_S - 100$		mV
I_{sc}	Short Circuit Current		120	215		mA
I_o	Output Current	$V_{OUT} = 7.5\text{ V}$, Input offset voltage 10 mV	90	170		mA
PSRR	Power Supply Rejection Ratio			80		dB
SR	Slew Rate	$A_V = 1$, $V_{IN} = 2\text{ Vpp}$		55		V/ μs
BW	-3db Bandwidth	$A_V = 1$, $V_{OUT} = 60\text{ mVpp}$		50		MHz
GBWP	Gain Bandwidth Product			36		MHz

(1) The maximum charge pump output current is typically one-half the drive current of the internal current source.

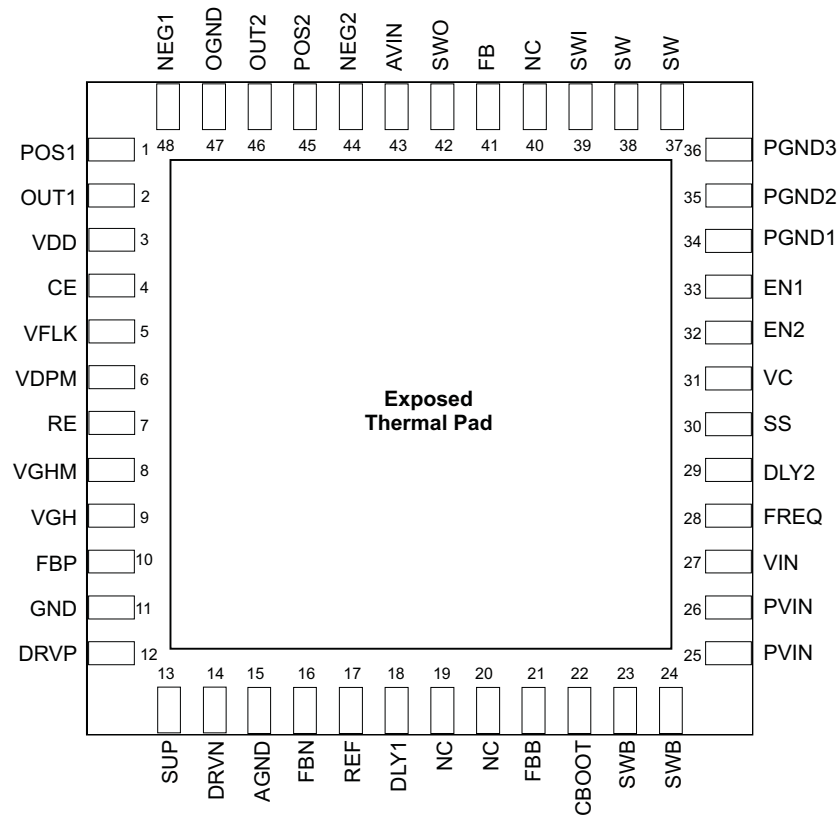
**PIN ASSIGNMENT
Top View**

NOTE: The thermally-enhanced PowerPAD is connected to PGND1 (Device power Ground). NC pin is internally not connected.

TERMINAL FUNCTIONS

TERMINAL		I/O	DESCRIPTION
NAME	NO.		
POS1	1	I	Non inverting input of Operational Amplifier 1
OUT1	2	O	Output of Operational Amplifier 1.
VDD	3	I	Threshold voltage of gate voltage shaping. The five times of voltage applied to this pin set the threshold discharge voltage for the gate voltage shaping function
CE	4	I	Delay of gate voltage shaping. Sets the delay between the falling edge of VFLK to the falling edge of VGHM
VFLK	5	I	Control of gate voltage shaping.
VDPM	6	I	Enable of gate voltage shaping block.
RE	7	O	Slope adjustment of gate voltage shaping. Connecting a resistor to this pin allows to adjust the slop of gate voltage shaping.
VGHM	8	O	Output of the gate voltage shaping block.
VGH	9	I	High voltage for gate voltage shaping block. Connect the output of the positive charge pump to this pin.
FBP	10	I	Feedback of the positive charge pump.
GND	11		Ground for positive and negative charge pump.
DRVP	12	O	Drive pin of the positive charge pump.
SUP	13	I	Supply pin of the positive charge pump
DRVN	14	O	Drive pin of the negative charge pump
AGND	15		Analog ground
FBN	16	I	Feedback of the negative charge pump.

TERMINAL FUNCTIONS (continued)

TERMINAL		I/O	DESCRIPTION
NAME	NO.		
REF	17	O	Internal reference output. Connect 220-nF capacitor directly from this pin to AGND to minimize possible noise coupling into the reference of the IC.
DLY1	18	O	Connecting a capacitor from this pin to GND allows setting the delay time between the step down converter and negative charge pump VGL.
NC	19, 20, 40		Not connected.
FBB	21	I	Feedback of the buck converter.
CBOOT	22	I	N-channel MOSFET gate drive voltage for the buck converter. Connect a capacitor from this pin to SWB.
SWB	23, 24	O	Switch pin of the buck converter
PVIN	25, 26	I	Power input for the buck converter.
VIN	27	I	Analog input voltage of the device. This pin should be bypassed with a 1- μ F capacitor for good filtering.
FREQ	28	I	Frequency selection pin. With FREQ=high, the device operates with 750 kHz. With FREQ=low, the device operates with 500kHz.
DLY2	29	O	Connecting a capacitor from this pin to GND allows setting the delay time between the step down converter and positive charge pump VGH.
SS	30	O	soft-start of the boost converter. Connect a capacitor from this pin to GND.
VC	31	O	Compensation pin of the boost converter.
EN2	32	I	Enable pin of the boost converter block.
EN1	33	I	Enable pin of the buck converter and negative charge pump. When this pin is pulled high, the buck converter starts up, and after a delay time set by DLY1, the negative charge pump starts up. A logic high enables the device and a logic low shut down the device.
PGND1	34		Power ground.
PGND2	35		Ground for boost converter.
PGND3	36		
SW	37, 38	I	Switch pin of the boost converter
SWI	39	I	Input of the isolation switch. The SWI pin is connected to internal overvoltage protection comparator.
FB	41	I	Feedback of the boost converter generating Vs
SWO	42	O	Output of the isolation switch
AVIN	43	I	Power input voltage pin for Operational Amplifier. Connect AVIN to the input of the isolation switch, SWI. Bypass this pin with a 1- μ F bypass capacitor.
NEG2	44	I	Inverting input of Operational Amplifier 2
POS2	45	I	Non inverting input of Operational Amplifier 2
OUT2	46	O	Output of Operational Amplifier 2
OGND	47		Ground for Operational Amplifier.
NEG1	48	I	Inverting input of Operational Amplifier 1

FUNCTIONAL BLOCK DIAGRAM

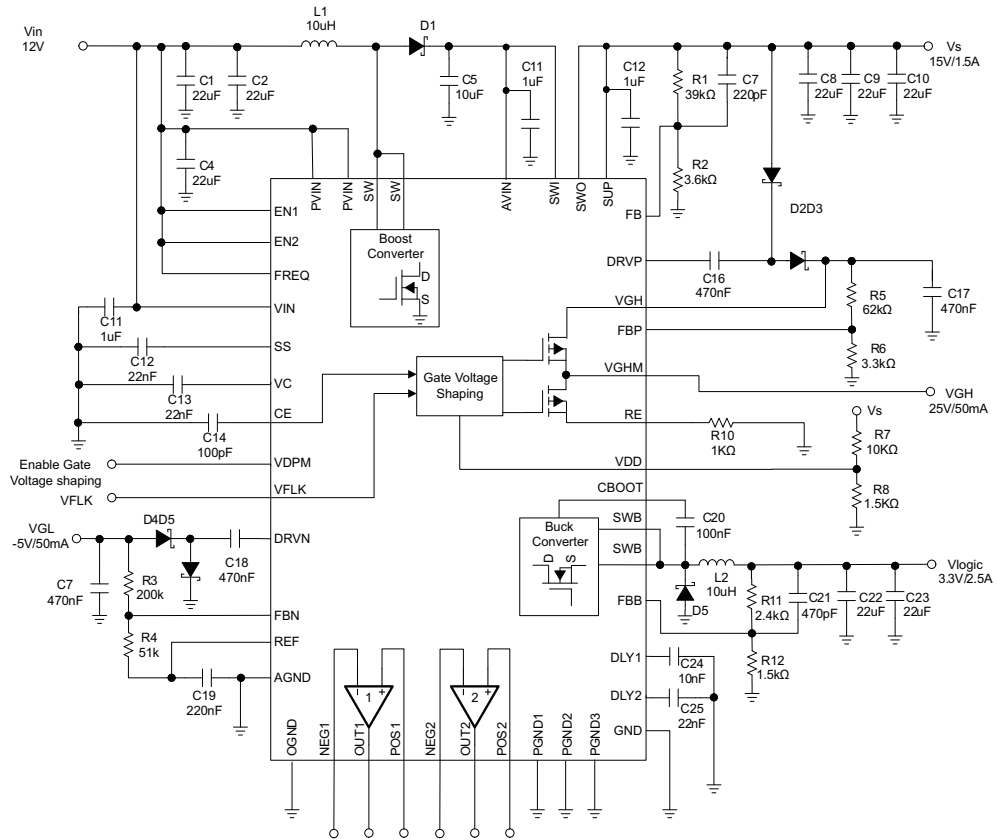

TYPICAL CHARACTERISTICS

Table of Graphs

			FIGURE
Main Boost Converter (Vs)			
η	Efficiency	vs Load current	Figure 1
	Soft start		Figure 2
	PWM operation	at nominal load current	Figure 3
	PWM operation	at light load current	Figure 4
	Load transient response		Figure 5
	Short-circuit protection		Figure 6
	Overvoltage protection		Figure 7
Step-Down Converter (Vlogic)			
η	Efficiency	vs Load current	Figure 8
	PWM operation	at nominal load current	Figure 9
	PWM operation	at light load current	Figure 10
	Soft start		Figure 11
	Load transient response		Figure 12
System Performance			
	Powerup sequencing	EN2 connected to VIN	Figure 13
	Powerup sequencing	EN2 enabled separately	Figure 14
	Gate voltage shaping		Figure 15
Negative Charge Pump Driver			
	VGL	vs VGL Load current	Figure 16
VCOM BUFFERS			
	-3 dB bandwidth, opamp		Figure 17
	Slew rate, opamp		Figure 18

BOOST CONVERTER (V_S)

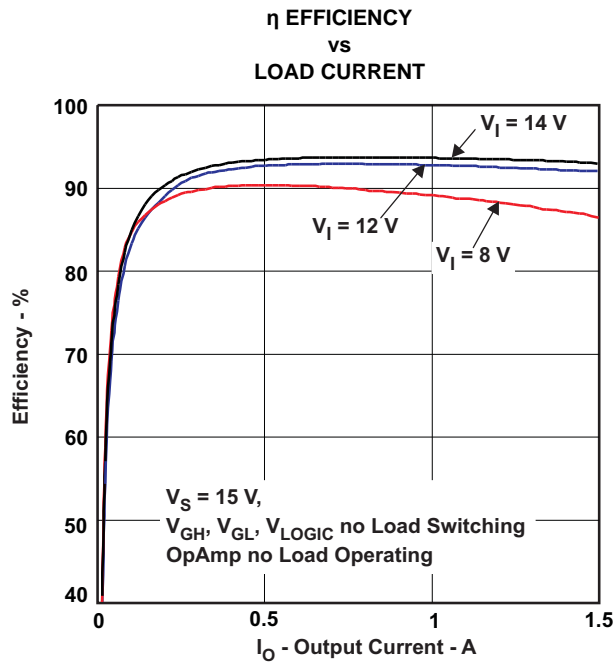

Figure 1.

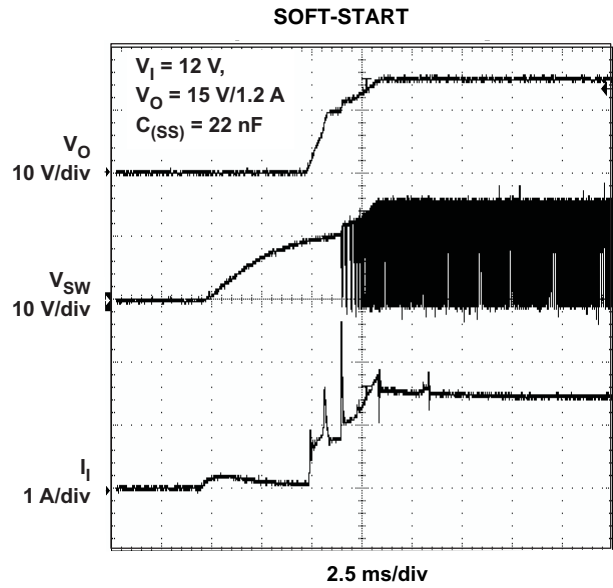

Figure 2.

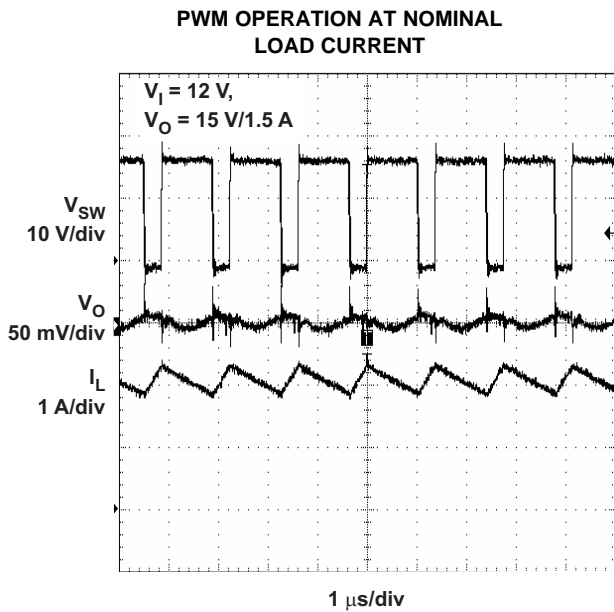

Figure 3.

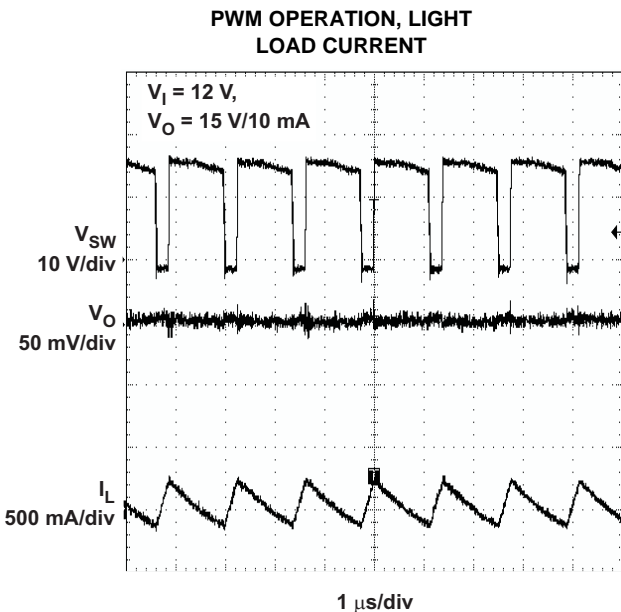

Figure 4.

LOAD TRANSIENT RESPONSE

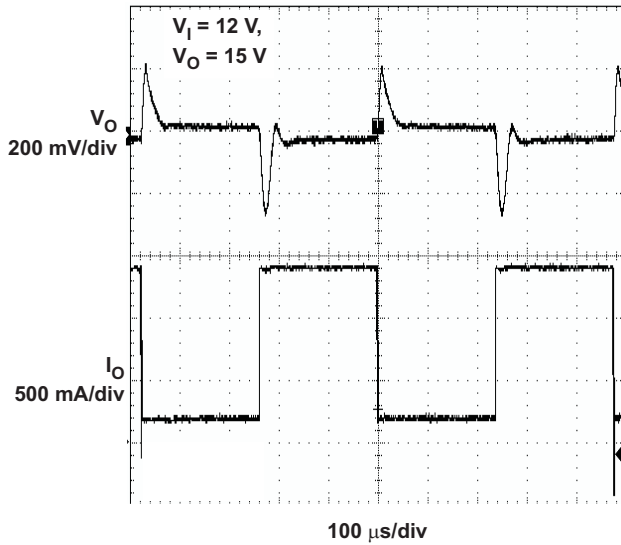

Figure 5.

SHORT CIRCUIT PROTECTION

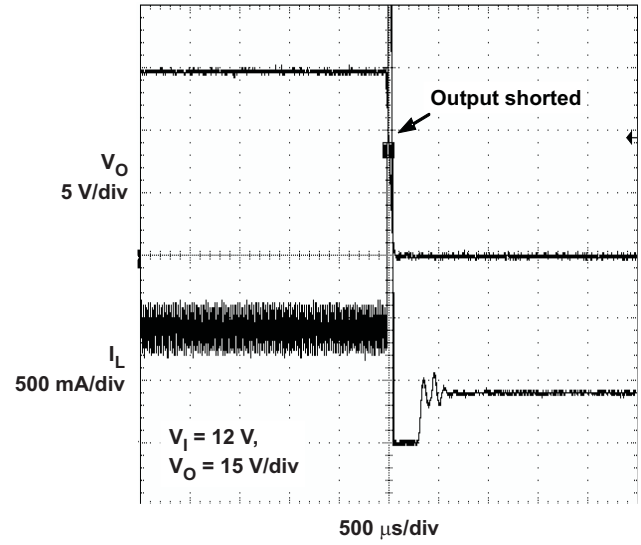

Figure 6.

OVERVOLTAGE PROTECTION

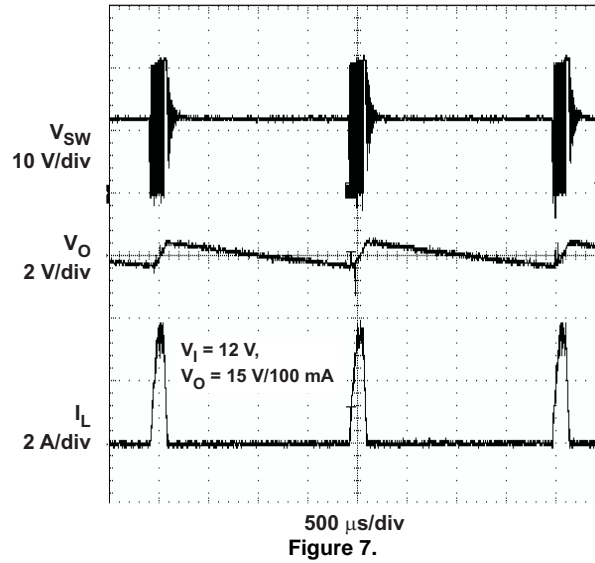
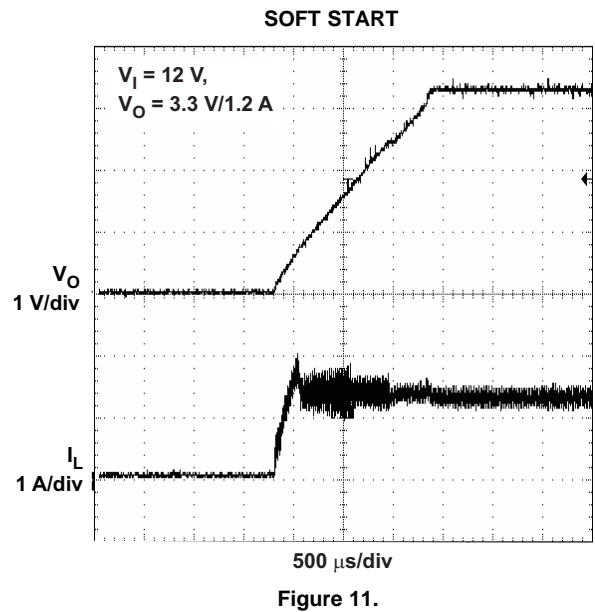
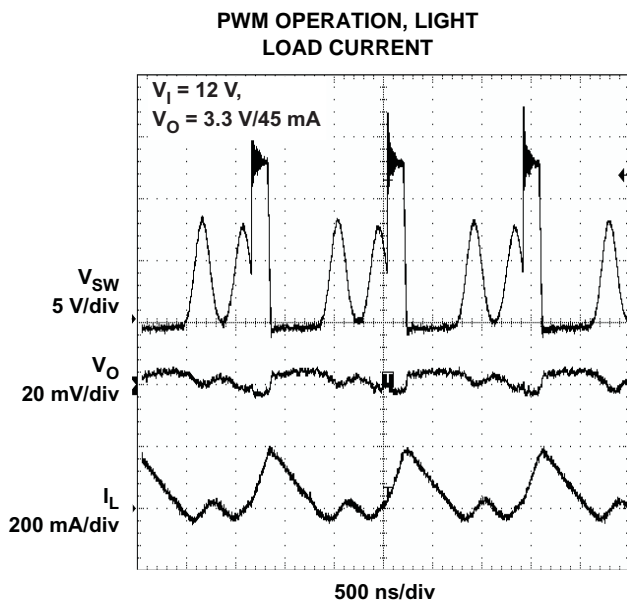
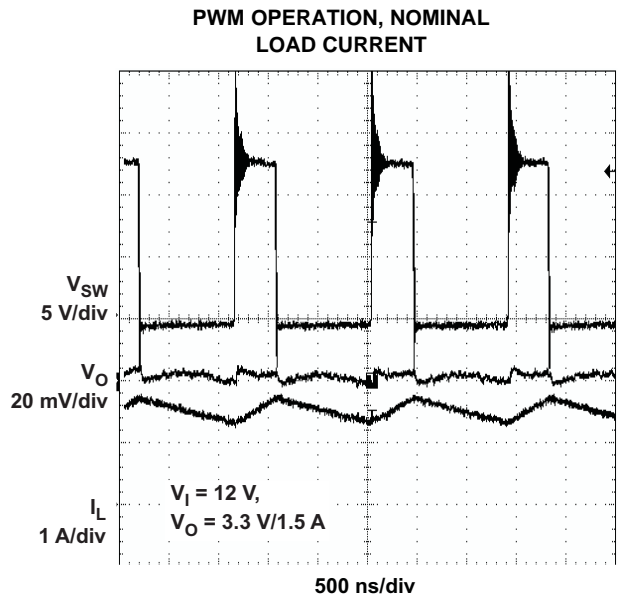
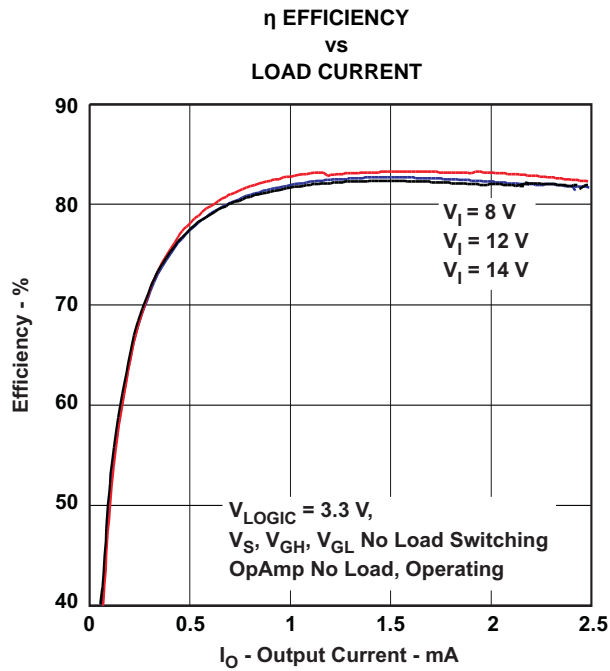

Figure 7.

STEP-DOWN CONVERTER (V_{logic})



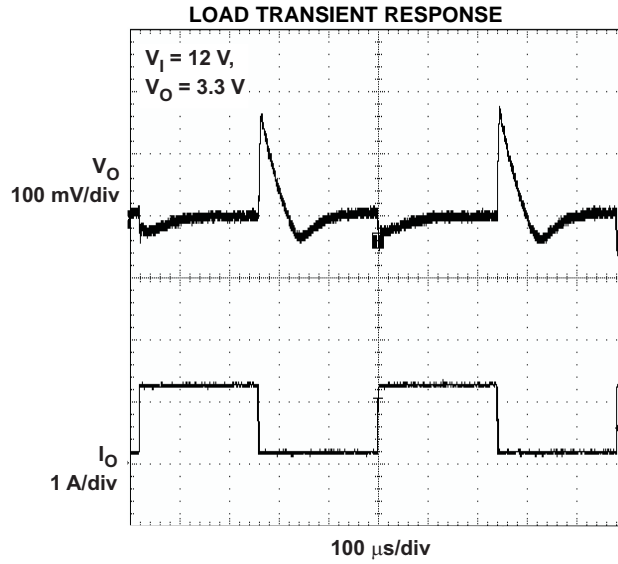

Figure 12.

SYSTEM PERFORMANCE

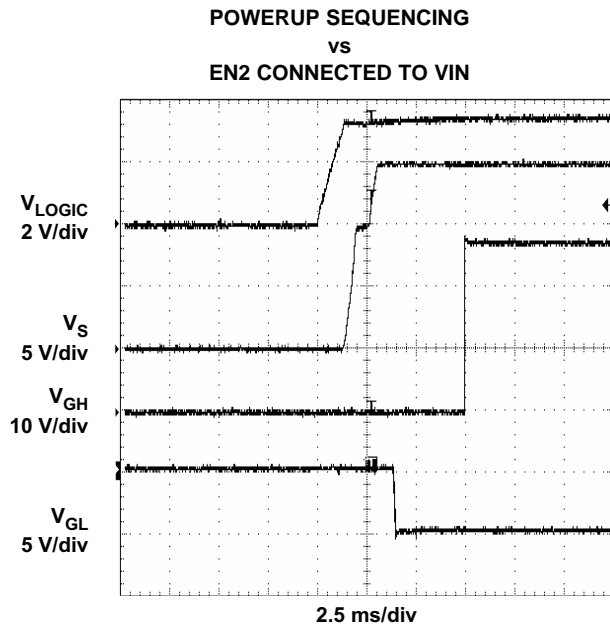

Figure 13.

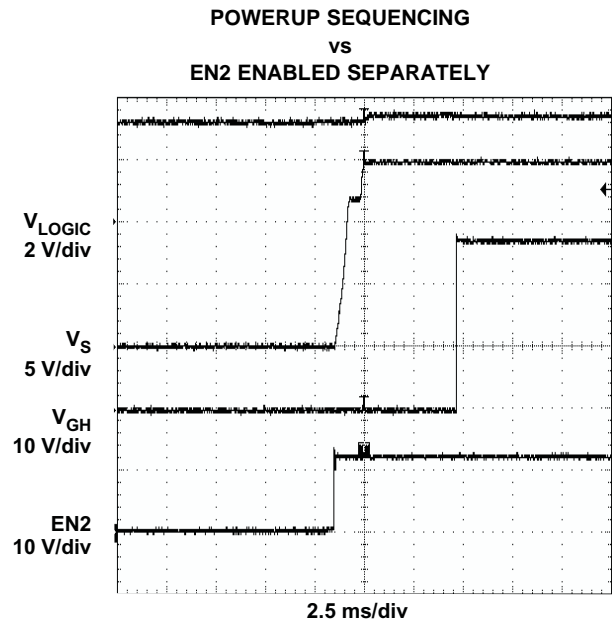

Figure 14.

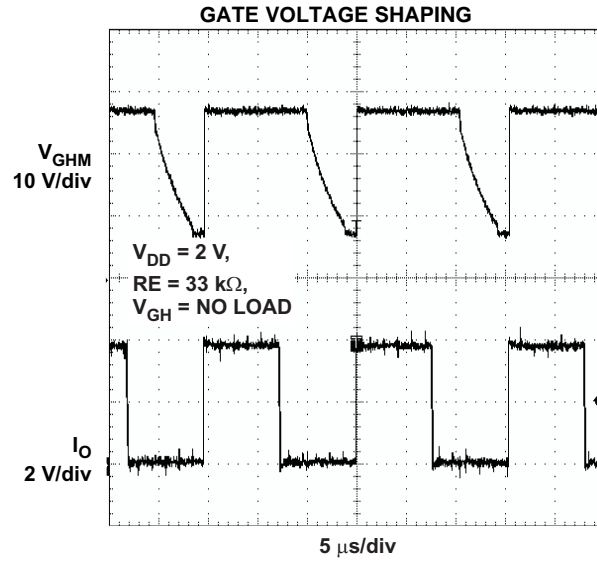

Figure 15.

NEGATIVE CHARGE PUMP DRIVER

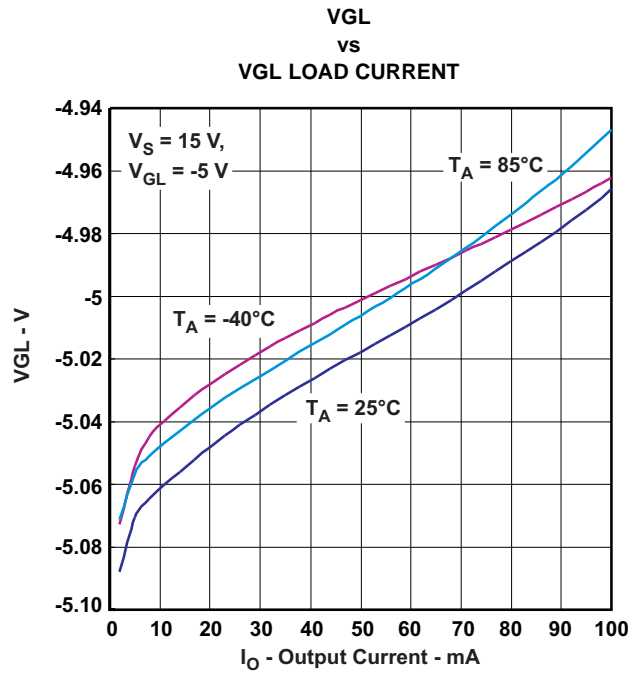

Figure 16.

VCOM BUFFERS

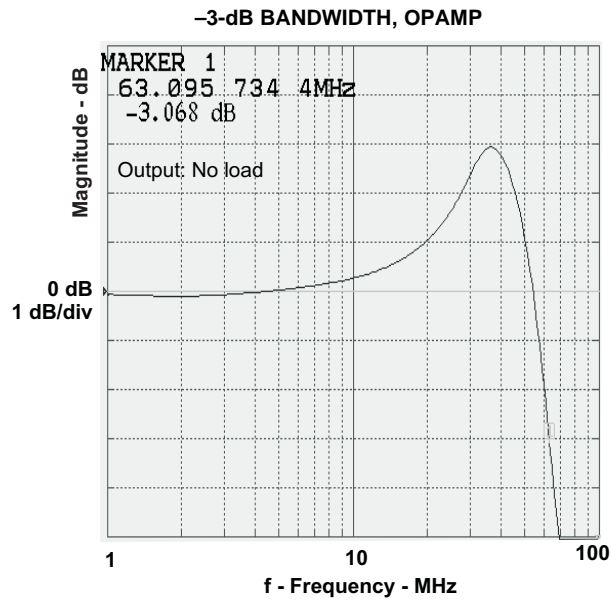

Figure 17.

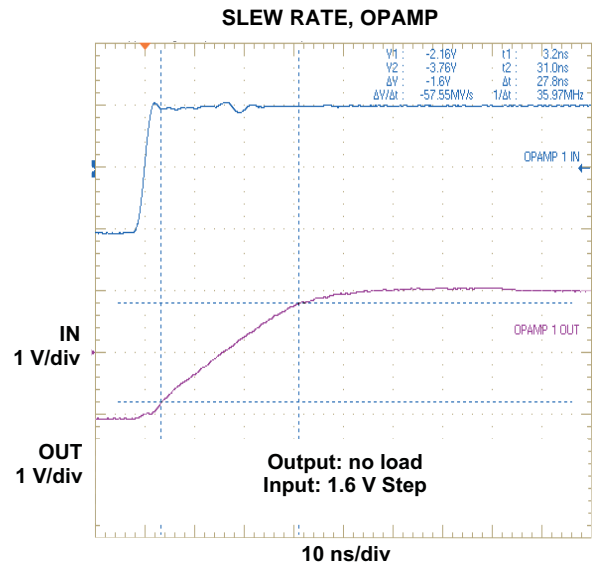

Figure 18.

APPLICATION INFORMATION

THERMAL SHUTDOWN

The thermal-shutdown feature prevents damage from excessive heat and power dissipation. Typically, the thermal-shutdown threshold is 160°C. When the temperature drops below the thermal shutdown threshold, the device restarts again automatically.

UNDERVOLTAGE LOCKOUT

To avoid device malfunction at low input voltages, an undervoltage lockout is included, which shuts down the device at voltages lower than 7.6 V.

REFERENCE OUTPUT, REF

The device provides a reference output that is used to regulate the negative charge pump. In order to have a stable reference voltage, a 220-nF bypass capacitor is required, connected directly from REF to AGND. The reference output has a current capability of 30 μ A which should not be exceeded. Because of this, the feedback resistor from FBN to REF should not be smaller than 40 k Ω .

START-UP SEQUENCING

The start-up sequencing can be set by adjusting the capacitors connected to DLY1 and DLY2, and is controlled by the signals EN1 and EN2. Pulling EN1 high enables the step-down converter. After the step down converter has reached its power-good threshold, the other sequence timings are started. DLY1 sets the delay time between the step-down converter and the negative charge-pump driver. This delay starts when the power-good threshold of the step-down converter is reached. A high level on EN2 enables the boost converter. The boost converter starts when the power-good threshold of the step down converter is reached and EN2 is pulled high. DLY2 sets the delay time for the positive charge pump. This delay time starts when the power good threshold of the step down converter is reached. After the delay time has expired, the positive charge pump and op-amps start up. As the positive charge pump power-good threshold is reached, then the GPM block is enabled if VDPM is high as well. See [Figure 19](#).

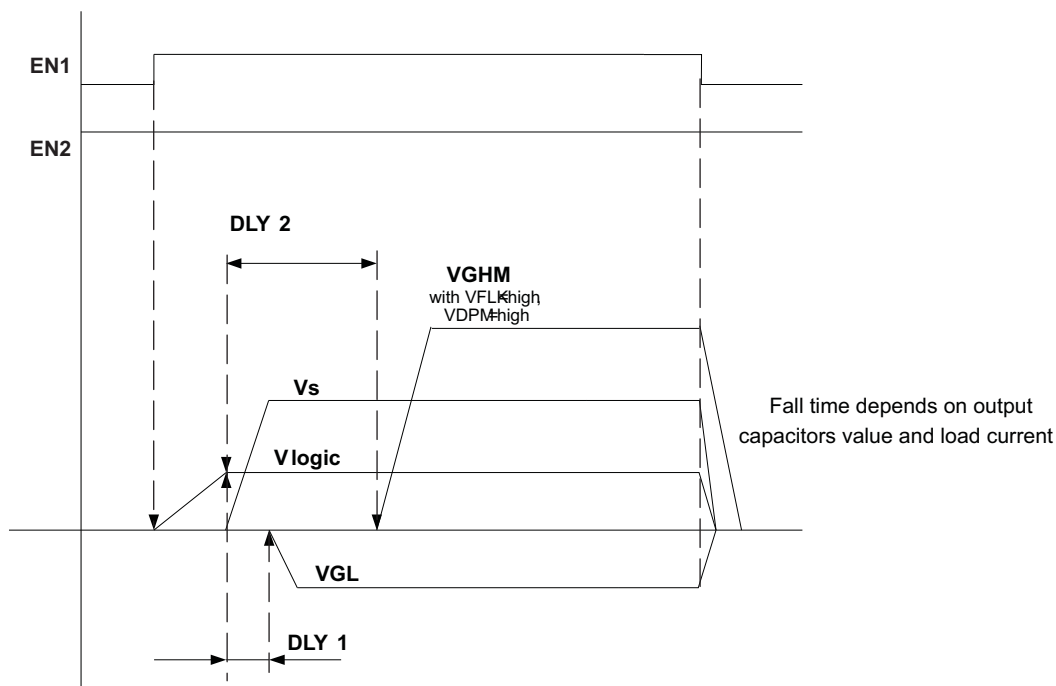

Figure 19. Power-On Sequencing With EN2 Always High (EN2=VIN)

If EN2 goes high after the step down converter is already enabled, then the delay DLY2 starts when EN2 goes high. See [Figure 20](#).

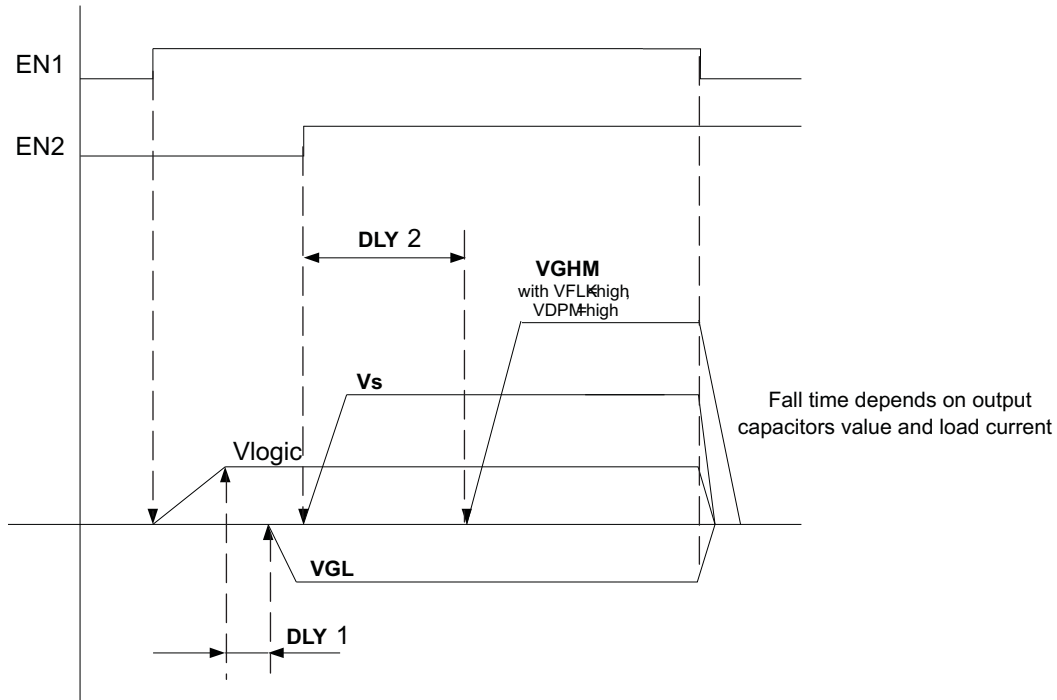

Figure 20. Power-on Sequencing Using EN1 and EN2

SETTING THE DELAY TIMES DLY1, DLY2

Connecting an external capacitor to the DLY1 and DLY2 pin sets the delay time. If no delay time is required these pins can be left open. To set the delay time the external capacitor connected to DLY1 and DLY2 is charged with a constant current source of typically 5 μA . The delay time is terminated when the capacitor voltage has reached the internal reference voltage of $V_{\text{REF}} = 1.280 \text{ V}$. The external delay capacitor is calculated using [Equation 1](#):

$$C_{\text{dly}} = \frac{5 \mu\text{A} \times t_d}{V_{\text{REF}}} = \frac{5 \mu\text{A} \times t_d}{1.280 \text{ V}}$$

where t_d = Desired delay time (1)

Example for setting a delay time of 5.3 ms:

$$C_{\text{dly}} = \frac{5 \mu\text{A} \times 5.3 \text{ ms}}{1.280 \text{ V}} = 20.7 \text{ nF} \approx 22 \text{ nF} \quad (2)$$

BOOST CONVERTER

The TPS65162 boost converter block is shown in Figure 21. The boost converter operates with PWM (Pulse Width Modulation) at a fixed switching frequency of 500 kHz or 750 kHz, selected by the FREQ pin. The converter uses a unique fast-response, voltage-mode controller scheme with input-voltage feedforward. This achieves excellent line and load regulation (0.03%/A load regulation typical), and allows the use of small external components. To add more flexibility to the selection of external component values, the device uses external loop compensation. Although the boost converter looks like a non-synchronous boost converter topology operating in discontinuous-conduction mode under a light load, the TPS65162 remains in continuous-conduction mode even under light load currents. (Figure 4) This is achieved with a novel architecture using an external Schottky diode with an integrated MOSFET in parallel connected between the SW pin and the SUP pin. This MOSFET allows the current to go below ground, which is the case under light load conditions. For this use, a small integrated P-Channel MOSFET (Q2) with typically $9\ \Omega\ r_{DS(on)}$ is sufficient. When the inductor current is positive, the external Schottky diode, with the lower forward voltage, carries the current. This causes the converter to operate with a fixed frequency in continuous-conduction mode over the entire load-current range. This avoids ringing on the switch pin as seen with a standard non-synchronous boost converter, and allows a simpler compensation circuit for the boost converter.

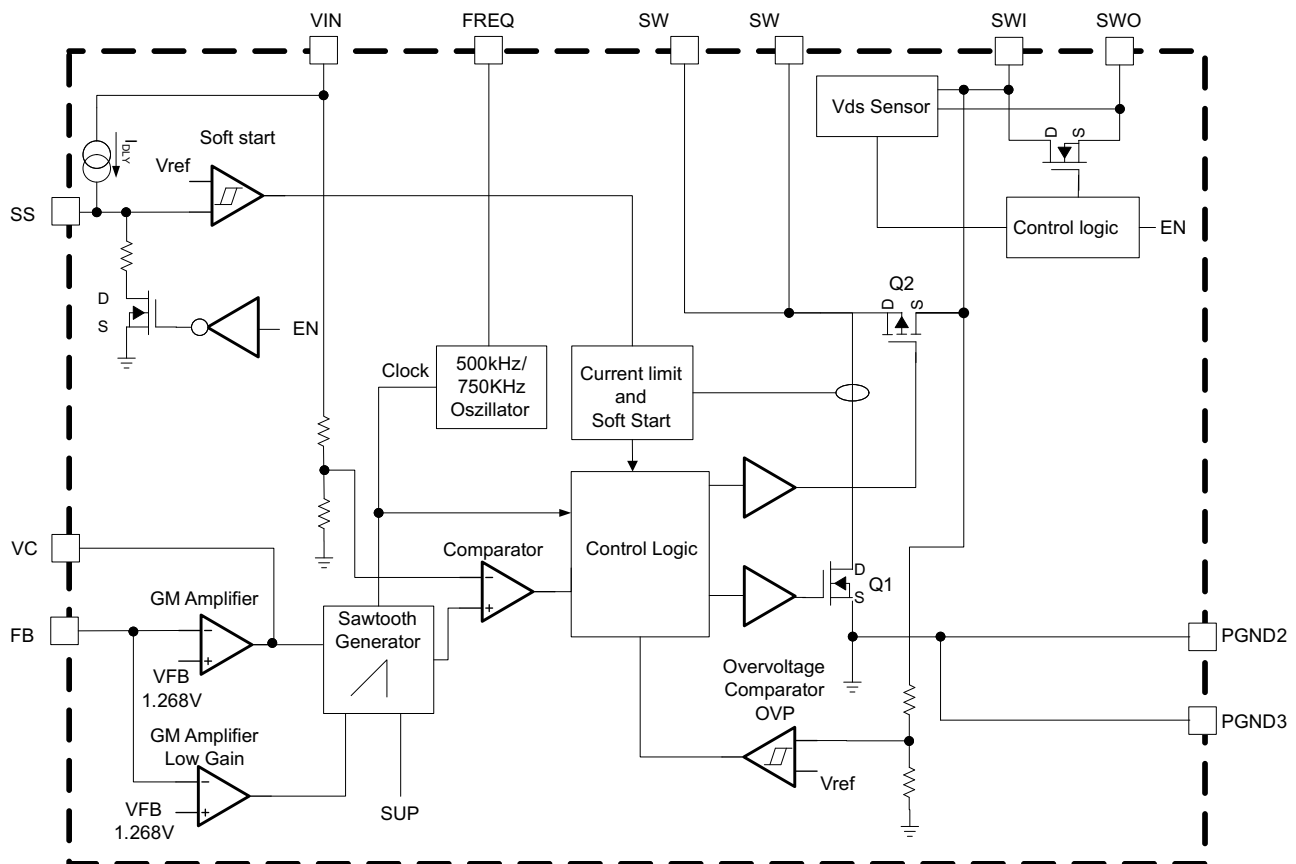

Figure 21. Boost Converter Block TPS65162

Soft Start

To minimize inrush current during startup, the boost converter has an adjustable soft-start, and the input-to-output isolation switch has current-limit control. The current limit of the input-to-output isolation switch is slowly ramped up for a soft turn-on. The VDS sensor of the input-to-output isolation switch monitors the voltage difference between SWI and SWO, and controls the current through the isolation switch. With VDS = 12 V, the current-limit threshold through the isolation switch is typically 330 mA. This current-limit threshold will linearly increase by factor of two till VDS reaches 3 V; current limiting is disabled when VDS is below 3 V. The boost converter is enabled when VDS is below 0.5 V. An external capacitor connected to the soft-start pin, SS, is used to slowly ramp up the internal switch current limit of the boost converter. The capacitor connected to the SS pin is charged with a constant current that increases the voltage on the SS pin. The internal current limit is proportional to the voltage on the SS pin. When the threshold voltage of the internal-switch soft-start comparator is reached, the full current limit is released. The larger the soft-start capacitor value, the longer the soft-start time. A 22-nF capacitor is usually sufficient for typical applications.

Overvoltage Protection

The boost converter has an overvoltage-protection circuit to prevent the switch voltage from exceeding the absolute-maximum switch voltage rating in the event of a system fault. The device protects itself if the feedback pin is connected to ground or floated, and clamps the voltage of the output of the boost converter to 20 V. To implement the overvoltage protection, the overvoltage comparator shown in [Figure 21](#) monitors the output voltage via the SWI pin. As soon as the output voltage exceeds the overvoltage threshold (typically 20 V), the device stops switching until the output voltage drops below the comparator threshold again. The typical waveform when the device is in overvoltage protection is shown in [Figure 7](#).

Short Circuit Protection

The boost converter has a short-circuit protection circuit to prevent the inductor or rectifier diode from overheating when the output is shorted. The VDS sensor in the input-to-output isolation switch monitors the voltage difference between SWI and SWO. If the boost output is shorted, and the voltage difference between SWI and SWO exceeds the threshold (typically 1.4 V in full operation), then the boost converter shuts down, and the input-to-output isolation switch limits VS current.

Input Capacitor Selection (VIN, SUP)

Low ESR ceramic capacitors are recommended for good input-voltage filtering. The TPS65162 has an analog input (VIN) as well as a power supply input (SUP) powering all the internal rails. A 1- μ F bypass capacitor is required as close as possible from VIN to GND, and from SUP to GND. Depending on the overall load current, two or three 22- μ F input capacitors are required. For better input-voltage filtering, the input capacitor values can be increased. Refer to [Table 1](#) and the [Typical Applications](#) schematic for input capacitor recommendations.

Table 1. Input Capacitor Selection

CAPACITOR	COMPONENT SUPPLIER	COMMENTS
22 μ F / 16 V	Taiyo Yuden EMK316BJ226ML	Pin VIN, PVIN
2 \times 10 μ F / 25 V	Taiyo Yuden TMK316BJ106KL	Pin VIN, PVIN (Alternative)
1 μ F / 35 V	Taiyo Yuden GMK107BJ105KA	Pin SUP, AVIN, VIN
1 μ F / 25 V	Taiyo Yuden TMK107BJ105KA	Pin SUP, AVIN, VIN

Frequency Select Pin, FREQ

The frequency-select pin FREQ selects the switching frequency of the entire device to 500 kHz (FREQ=low) or 750 kHz (FREQ=high). A lower switching frequency gives a higher efficiency with a slightly reduced load-transient regulation.

Boost Converter Design Procedure

The first step in the design procedure is to verify whether the maximum possible output current of the boost converter supports the specific application requirements. To simplify the calculation, the fastest approach is to estimate the converter efficiency, by taking the efficiency numbers from the provided efficiency curves, or to use a worst-case assumption for the expected efficiency, e.g., 80%. With the efficiency number it is possible to calculate the steady-state values of the application.

1. Converter Duty Cycle:
$$D = 1 - \frac{V_{in} \times \eta}{V_{out}}$$
2. Maximum output current:
$$I_{out} = \left(I_{sw} - \frac{V_{in} \times D}{2 \times f_s \times L} \right) \times (1 - D)$$
3. Peak switch current:
$$I_{swpeak} = \frac{V_{in} \times D}{2 \times f_s \times L} + \frac{I_{out}}{1 - D}$$

With I_{sw} = converter switch current (minimum switch current limit = 2.8 A)

f_s = converter switching frequency (typical 500kHz or 750 kHz)

L = Selected inductor value

η = Estimated converter efficiency (use the number from the efficiency curves or 0.8 as an estimation)

The peak switch current is the steady-state peak switch current that the integrated switch, inductor and external Schottky diode must be able to handle. The calculation must be done for the minimum input voltage where the peak switch current is highest.

Inductor Selection

The TPS65162 typically operates with a 10- μ H inductor. The main parameter for inductor selection is the inductor saturation current, which should be higher than the peak switch current, as calculated above, with additional margin to handle heavy load transients. An alternative more conservative approach is to choose an inductor with a saturation current at least as high as the typical switch current limit of 3.6 A. The second important parameter is the inductor DC resistance. Usually, the lower the DC resistance, the higher the efficiency of the converter. The choice of inductor can affect converter efficiency by as much as 10%. Example inductors are shown in [Table 2](#).

Table 2. Inductor Selection (Boost Converter)

INDUCTOR VALUE	COMPONENT SUPPLIER	DIMENSIONS in mm	I_{sat}/DCR
10 μ H	Coilcraft DO3316P-103	12.95 × 9.4 × 5.51	3.9 A / 38 m Ω
10 μ H	Sumida CDRH8D43-100	8.3 × 8.3 × 4.5	4.0 A / 29 m Ω
10 μ H	Wuerth Elektronik 744066100	10 × 10 × 3.8	4.0 A / 25 m Ω

Output Capacitor

For best output-voltage filtering, a low-ESR output capacitor is recommended. Ceramic capacitors have a low ESR value and work best with the TPS65162. One 10- μ F ceramic output capacitor before the input-to-output isolation switch, SWI, and six 10- μ F or three 22- μ F ceramic output capacitors in parallel after the input-to-output isolation switch, SWO, are sufficient for most applications. To improve the load transient regulation, add more capacitors after the input-to-output isolation switch. Refer to [Table 3](#) for the selection of the output capacitor.

Table 3. Output Capacitor Selection

CAPACITOR	COMPONENT SUPPLIER	COMMENTS
10 μ F/25 V	Taiyo Yuden TMK316BJ106KL	
22 μ F/25 V	TDK C4532X7R1E226M	Alternative solution

Rectifier Diode Selection

To achieve high efficiency, a Schottky diode should be used. The reverse voltage rating should be higher than the maximum output voltage of the converter. The current rating for the Schottky diode is calculated as the off time of the converter times the typical switch current of the TPS65162:

$$I_{\text{avg}} = (1-D) \cdot I_{\text{SW}} = \frac{V_{\text{in}}}{V_{\text{out}}} \times 3.6 \text{ A}$$

where I_{SW} = typical switch current of the TPS65162 (3.6 A) (3)

A Schottky diode with 2-A maximum average rectified forward current rating is sufficient for most applications. The Schottky rectifier must have adequate power dissipation. The dissipated power is the average rectified forward current times the diode forward voltage.

$$P_{\text{D}} = I_{\text{avg}} \cdot V_{\text{F}} = I_{\text{SW}} \cdot (1-D) \cdot V_{\text{F}}$$

where I_{SW} = typical switch current of the TPS65162 (3.6 A) (4)

Table 4. Rectifier Diode Selection (Boost Converter)

I_{avg}	Vr	V_{forward}	$R_{\theta\text{JA}}$	SIZE	COMPONENT SUPPLIER
3 A	20 V	0.36 at 3 A	46°C/W	SMC	MBRS320, International Rectifier
2 A	20 V	0.44 V at 2 A	75°C/W	SMB	SL22, Vishay Semiconductor
2 A	20 V	0.5 at 2 A	75°C/W	SMB	SS22, Fairchild Semiconductor

Setting the Output Voltage and Selecting the Feedforward Capacitor

The output voltage is set by the external resistor divider and is calculated as:

$$V_{\text{out}} = 1.268 \text{ V} \times \left(1 + \frac{R1}{R2} \right)$$
 (5)

Across the upper resistor a bypass capacitor is required to speed up the circuit during load transients. The capacitor is calculated as:

$$C_{\text{ff}} = \frac{1}{2 \cdot \pi \cdot f_z \cdot R1}$$
 (6)

Depending on the inductor value, the zero frequency needs to be set. f_z is 19 kHz for a 10 μH inductor, and 9 kHz for a 22 μH inductor. A value coming closest to the calculated value should be used.

Compensation (VC)

The regulator loop can be compensated by adjusting the external components connected to the VC pin. The VC pin is the output of the internal transconductance error amplifier. A single capacitor connected to this pin sets the low frequency gain. A 22-nF capacitor is usually sufficient for most applications.

POSITIVE CHARGE PUMP

The positive charge pump provides a regulated output voltage set by the external resistor divider. The TPS65162 positive charge pump block is shown in Figure 22.

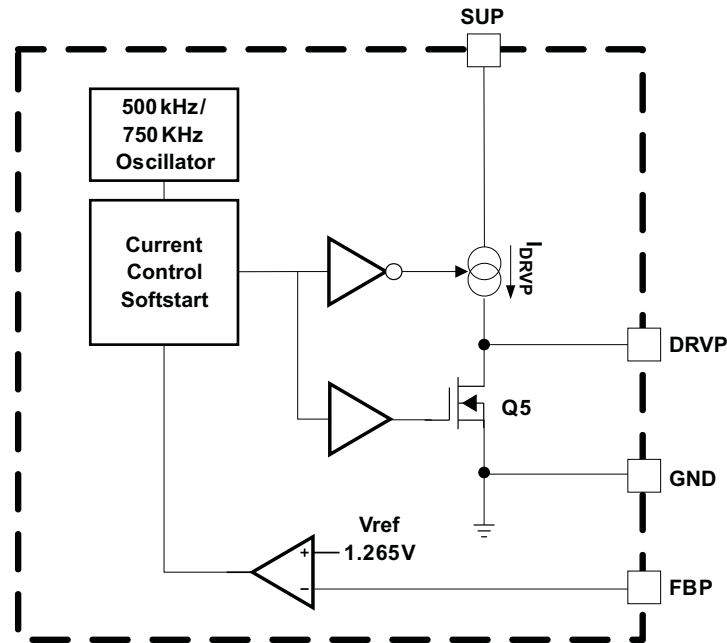

Figure 22. Positive Charge Pump Block TPS65162

Since the flying capacitor-voltage sits on top of the drive-pin voltage, the maximum output voltage is $V_{SUP} + V_S - V_{drop}$. V_{drop} is the voltage drop across the external diodes and internal charge pump MOSFETs. If higher output voltages are required, another charge pump stage can be added to the output.

Setting the output voltage:

$$V_{out} = V_{REF} \times \left(1 + \frac{R5}{R6}\right) = 1.265 \text{ V} \times \left(1 + \frac{R5}{R6}\right) \quad (7)$$

To minimize noise and leakage current sensitivity, we recommend a value of approximately 20 k Ω for the lower feedback divider resistor R6.

NEGATIVE CHARGE PUMP

The negative charge pump provides a regulated output voltage set by the external resistor divider. The TPS65162 negative charge pump block is shown in Figure 23. The negative charge pump operates very similar to the positive charge pump, with the difference that it runs from the input voltage VIN. The maximum negative output voltage is $V_{GL} = (-V_{IN}) + V_{drop}$. V_{drop} is the voltage drop across the external diodes and internal charge-pump MOSFETs.

The output voltage is calculated by:

$$V_{out} = -V_{REF} \times \frac{R3}{R4} = -1.265 \text{ V} \times \frac{R3}{R4} \quad (8)$$

Since the reference-output driver current should not exceed 30 μA (typical), the lower feedback resistor value R4 should be in a range of 40 k Ω to 120 k Ω . Overall feedback resistance should be in the range from 500 k Ω to 1 M Ω . The negative charge pump requires two external Schottky diodes. The peak current rating of the Schottky diode must be twice the load current of the output. For a 20-mA output current, the dual Schottky diode BAV99 is a good choice.

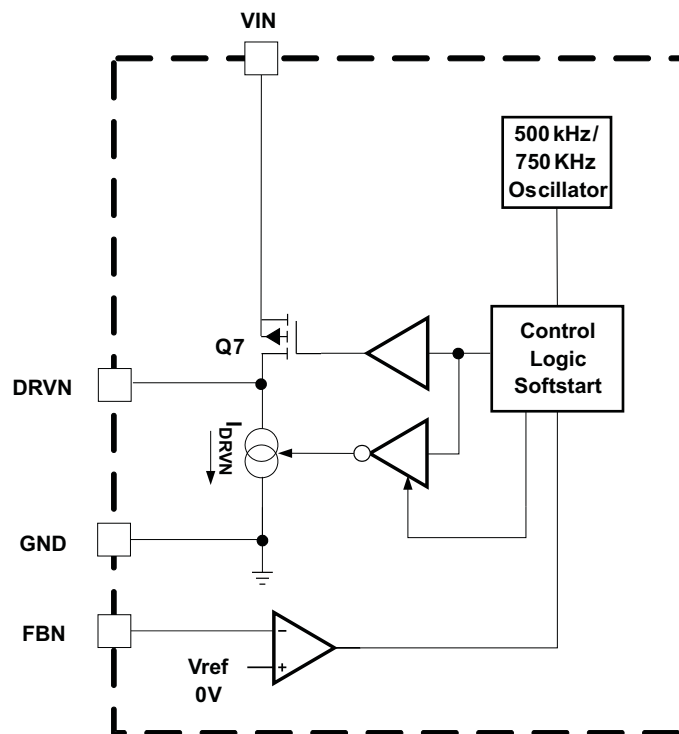

Figure 23. Negative Charge Pump Block TPS65162

GATE VOLTAGE SHAPING

The gate voltage shaping reduces the flickering effect of an LCD panel, and isolates VGHM from the source voltage VGH. For correct operation of this block, it is not recommended to connect an output capacitor to VGHM. To reduce the voltage ripple on VGHM, add more capacitors on VGH. The TPS65162 gate voltage shaping block is shown in Figure 24. The corresponding timing diagram is shown in Figure 26. The gate voltage shaping block responds to VFLK under the following conditions:

- The device is enabled with VDPM = high
- The input voltage is above the undervoltage lockout
- The positive charge pump is in regulation

When VGH is pulled below its power-good level, Q1 and Q2 are turned off and VGHM is discharged via the 1-kΩ resistor over Q3. With VFLK = high, Q1 and Q4 are turned on and Q2 is turned off. VGH is present at VGHM when Q1 is on, and at the same time, the capacitor connected to the CE pin is discharged by Q4 to GND. When VFLK is taken low, Q4 is turned off, and the capacitor connected to the CE pin is charged by a constant current source, typically 60 μA. When the capacitor voltage reaches the internal reference voltage of 1.284 V and VFLK is low, Q1 is turned off and Q2 is turned on. With Q2 on, VGHM is discharged by the resistor connected to the RE pin. Once VGHM is discharged to five times VDD, Q2 is turned off and VGHM is high impedance. In the application of not using this function, connect VDPM, VFLK with high.

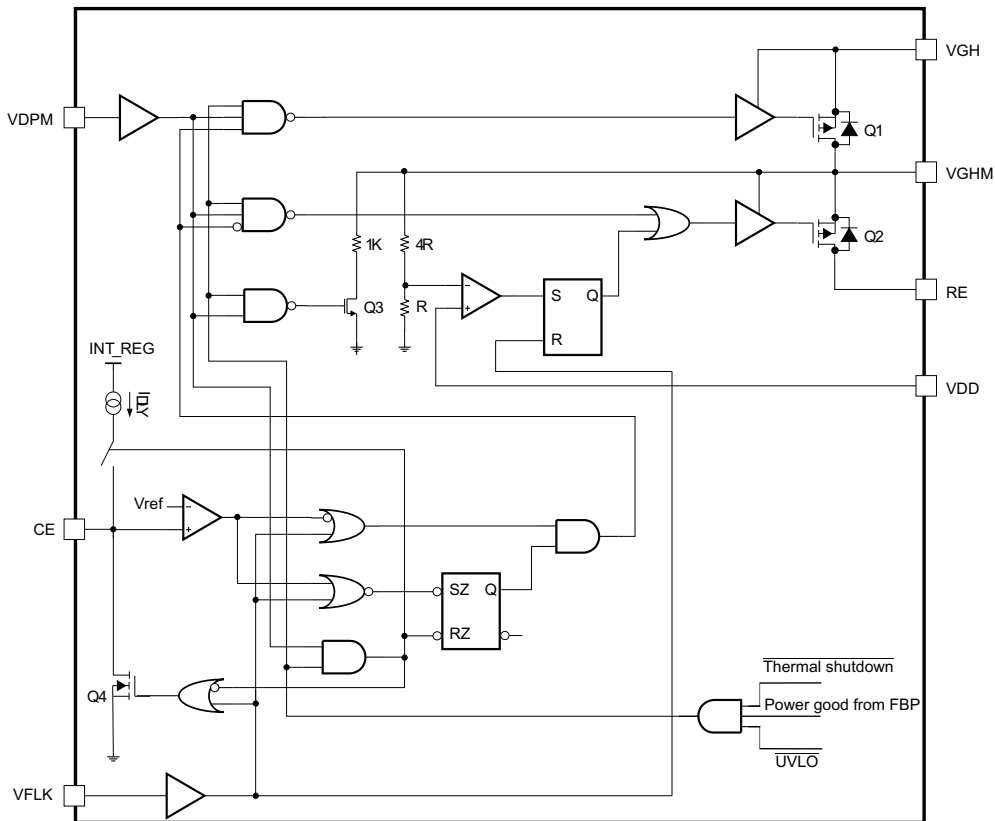

Figure 24. Gate Voltage Shaping Block TPS65162

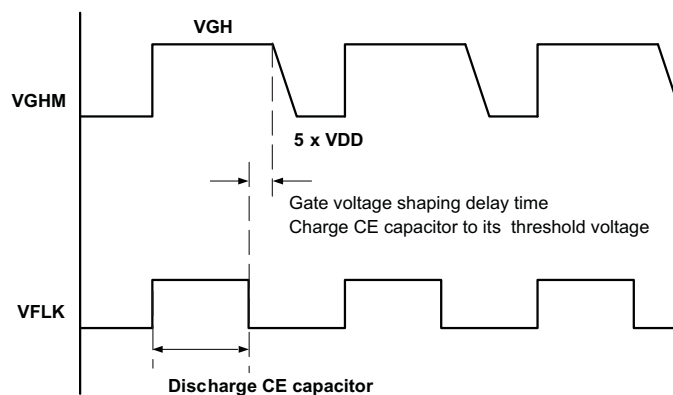

Figure 25. Gate Voltage Shaping Block TPS65162

STEP-DOWN CONVERTER

The TPS65162 step down converter block is shown in [Figure 26](#). The non-synchronous step down converter operates at a fixed switching frequency using a fast response voltage mode topology with input voltage feedforward. This topology allows simple internal compensation and it is designed to operate with ceramic output capacitors. The converter drives an internal 2.8 A N-Channel MOSFET switch. The MOSFET driver is referenced to the switch pin SWB. The N-Channel MOSFET requires a gate drive voltage higher than the switch pin to turn the N-Channel MOSFET on. This is accomplished by a boost strap gate drive circuit running of the step down converter switch pin. When the switch pin SWB is at ground the boot strap capacitor is charged to 8 V. This way the N-Channel Gate drive voltage is typically around 8 V.

Soft Start

To avoid high inrush current during startup, an internal soft-start is implemented. When the step down converter is enabled over EN1, its reference voltage slowly rises from zero to its power good threshold of typically 90% of Vref. When the reference voltage reaches this power good threshold, the Error amplifier is released to its normal operation with its normal duty cycle. To further limit the inrush current during soft-start the converter frequency is set to 1/4 of the switching frequency f_S and 1/2 of f_S by the comparator that monitors the feedback voltage. refer to the internal block diagram. The typical soft-start is typically completed within 1ms.

Short Circuit Protection

To limit the short circuit current, the device has a cycle-by-cycle current limit. To prevent the short-circuit current from rising above the internal current limit when the output is shorted to GND, the switching frequency is reduced as well. This is implemented by two comparators monitoring the feedback voltage. The step-down converter switching frequency is reduced to 1/2 of f_S when the feedback is below 0.9 V, and 1/4 of the switching frequency when the feedback voltage is below 0.6 V.

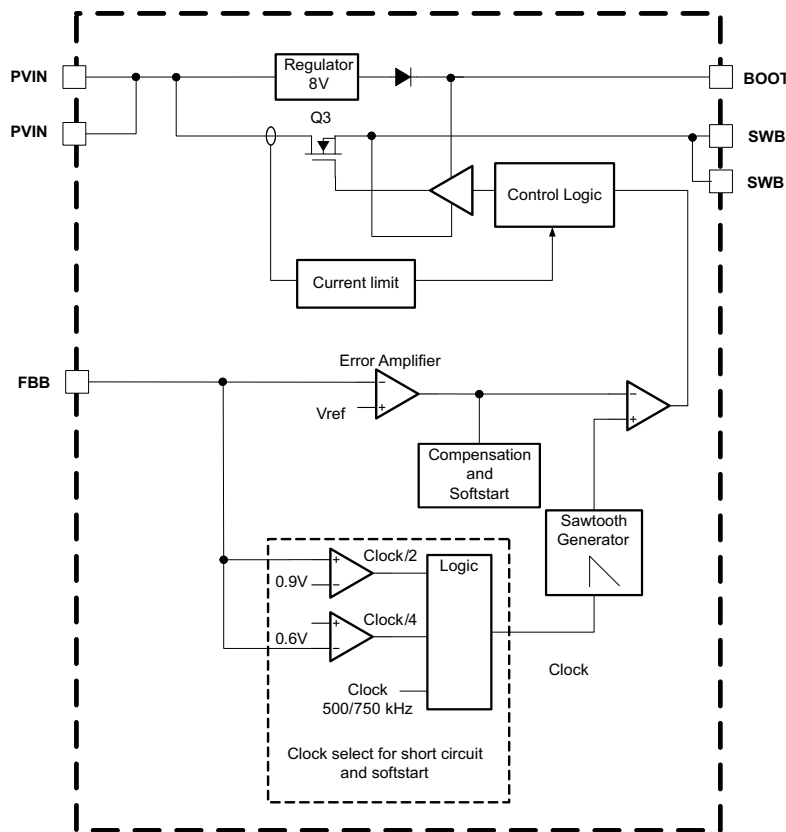

Figure 26. Step Down Converter Block TPS65162

Setting the Output Voltage

The step-down converter uses an external voltage divider to set the output voltage. The output voltage is calculated as:

$$V_{out} = 1.265 \text{ V} \times \left(1 + \frac{R5}{R6} \right) \quad (9)$$

At load currents <1 mA, the device operates in discontinuous conduction mode. When the load current is reduced to zero the output voltage rises slightly above the nominal output voltage. At zero load current, the device skips clock cycles, but does not completely stop switching, thus the output voltage sits slightly above the nominal output voltage. Therefore, the lower feedback resistor is selected to be around 1.2 kΩ to maintain around 1 mA minimum load current.

Selecting the Feedforward Capacitor

The feedforward capacitor across the upper feedback resistor divider forms a zero around 135 kHz, and is calculated as:

$$C_z = \frac{1}{2 \times \pi \times 135\text{kHz} \times R5} = \frac{1}{2 \times \pi \times 135\text{kHz} \times 2.5\text{k}\Omega} = 471.6 \text{ pF} \approx 470 \text{ pF} \quad (10)$$

Usually the standard capacitor value closest to the calculated value is selected.

Inductor Selection

The TPS65162 step-down converter typically operates with a 10-μH inductor. For high efficiency, the inductor should have a low DC resistance to minimize conduction loss. This must be considered when selecting the appropriate inductor. In order to avoid inductor saturation, the inductor should be rated at least for the maximum output current of the converter plus the inductor ripple current that will be calculated by:

$$\Delta I_L = V_{out} \times \frac{1 - \frac{V_{out}}{V_{in}}}{L \times f} \quad I_{Lmax} = I_{outmax} + \frac{\Delta I_L}{2} \quad (11)$$

where

- f = Switching Frequency (750 kHz, 500 kHz minimal)
- L = Inductor Value (typically 10 μH)
- ΔI_L = Peak to Peak inductor ripple current
- I_{Lmax} = Maximum Inductor current

The highest inductor current occurs at maximum V_{in} . A more conservative approach is to select the inductor current rating just for the typical switch-current limit of 3.5 A.

Table 5. Inductor Selection

INDUCTOR VALUE	COMPONENT SUPPLIER	DIMENSIONS in mm	I _{sat} /DCR
10 μH	Coilcraft DO3316P-103	12.95 × 9.4 × 5.51	3.9 A/38 mΩ
10 μH	Sumida CDRH8D43-100	8.3 × 8.3 × 4.5	4.0 A/29 mΩ
10 μH	Wuerth Elektronik 744066100	10 × 10 × 3.8	4.0 A/25 mΩ

Rectifier Diode Selection

To achieve high efficiency, a Schottky diode should be used. The reverse voltage rating should be higher than the maximum output voltage of the step-down converter. The averaged rectified forward current for which the Schottky diode should be rated is calculated as the off time of the step-down converter times the minimum switch current of the TPS65162:

$$D = \frac{V_{OUT}}{V_{IN}} \quad (12)$$

$$I_{avg} = (1-D) \cdot I_{SW} = \left(1 - \frac{V_{OUT}}{V_{IN}}\right) \cdot 2.8 \text{ A}$$

$$\text{where } I_{sw} = \text{minimum switch current of the TPS65162 (2.8 A)} \quad (13)$$

Usually a Schottky diode with 2 A maximum average rectified forward current rating is sufficient for most of the applications. Secondly the Schottky rectifier has to be able to dissipate the power. The dissipated power is the average rectified forward current times the diode forward voltage.

$$P_D = I_{avg} \times V_F = I_{sw} \times (1 - D) \times V_F \text{ with } I_{SW} = \text{minimum switch current of the TPS65162 (2.8 A)}$$

Table 6. Rectifier Diode Selection (Step-Down Converter)

CURRENT RATING I_{avg}	Vr	V _{forward}	R _{θJA}	SIZE	COMPONENT SUPPLIER
3 A	20 V	0.36 V at 3 A	46°C/W	SMC	MBRS320, International Rectifier
2 A	20 V	0.44 V at 2 A	75°C/W	SMB	SL22, Vishay Semiconductor
2 A	20 V	0.5 V at 2 A	75°C/W	SMB	SS22, Fairchild Semiconductor

Output Capacitor Selection

The device is designed to work with ceramic output capacitors. Two 22-μF output capacitors are sufficient for most of the applications. Larger output capacitance improves the load transient response.

Table 7. Output Capacitor Selection Step-Down Converter

CAPACITOR	COMPONENT SUPPLIER	COMMENT
22 μF/6.3 V	Taiyo Yuden JMK212BJ226MG	

OPERATIONAL AMPLIFIER 1 AND 2

The TPS65162 has two integrated operational amplifiers. The operational amplifiers can be used as a gamma-correction buffer or as a VCOM buffer.

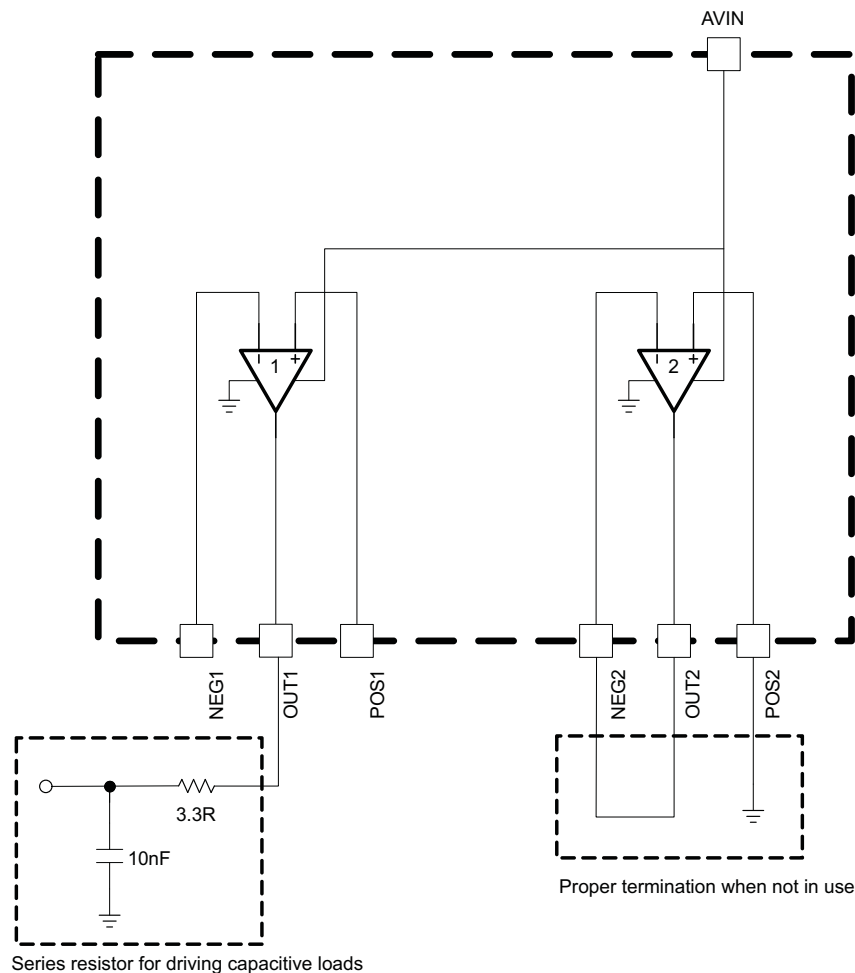

Figure 27. Operational Amplifier Block TPS65162

The power supply pin for the opamps is the AVIN pin connected to the input of the isolation switch of the boost converter. To achieve good performance and minimize the output noise, a 1- μ F bypass capacitor is required directly from the AVIN pin to ground. The opamps are not designed to drive capacitive loads; therefore, it is not recommended to connect a capacitor directly to the output of the opamps. If capacitive loads are driven, use a series resistor at the output to provide stable operation. With a 3.3- Ω series resistor, a capacitive load of 10 nF can be driven, which is usually sufficient for typical LCD applications.

Operational Amplifier Termination

For some applications, not all of the amplifiers are used. To minimize device quiescent current the terminals should be terminated. The negative terminal is connected to the output of the operational amplifier and positive terminal is connected to GND and the output is left open. This termination minimizes device quiescent current and maintains correct functionality of the device.

PCB LAYOUT DESIGN GUIDELINES

1. Place the power components outlined in bold first on the PCB.
2. Rout the traces outlined in bold with wide PCB traces.
3. Place a 1- μ F bypass capacitor directly from the SUP pin to GND and from AVIN to GND.

4. Use a short and wide trace to connect the SUP pin to the output of the boost converter Vs.
5. Place the 220-nF reference capacitor directly from REF to GND close to the IC pins.
6. The feedback resistor for the negative charge pump between FBN and REF should be $>40\text{ k}\Omega$.
7. Use short traces for the charge-pump drive pin (DRVN) of VGL because the traces carry switching waveforms.
8. Solder the PowerPAD™ of the QFN package to GND, and use thermal vias to lower the thermal resistance.
9. For more layout recommendations, refer to the TPS65162 evaluation module (EVM)

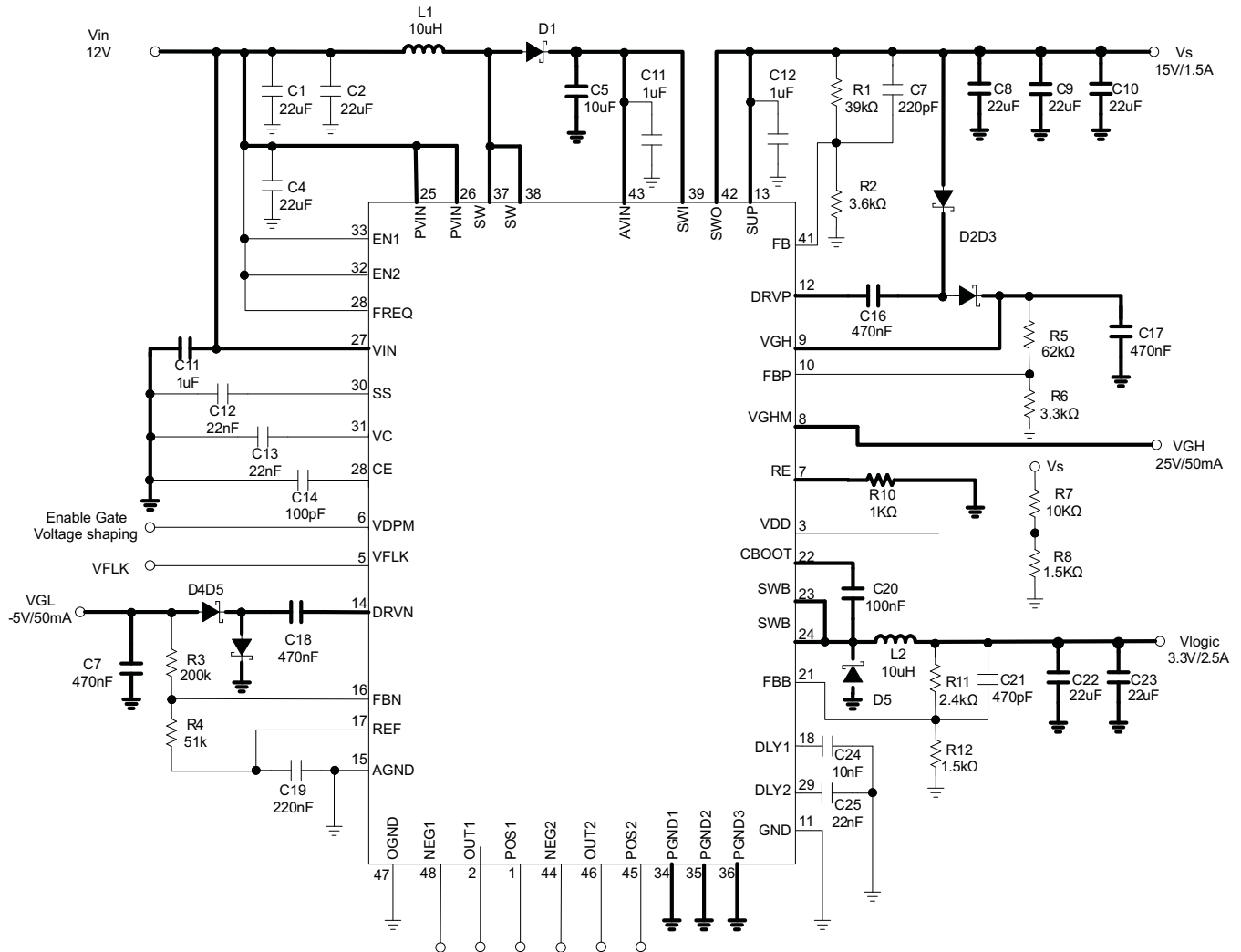
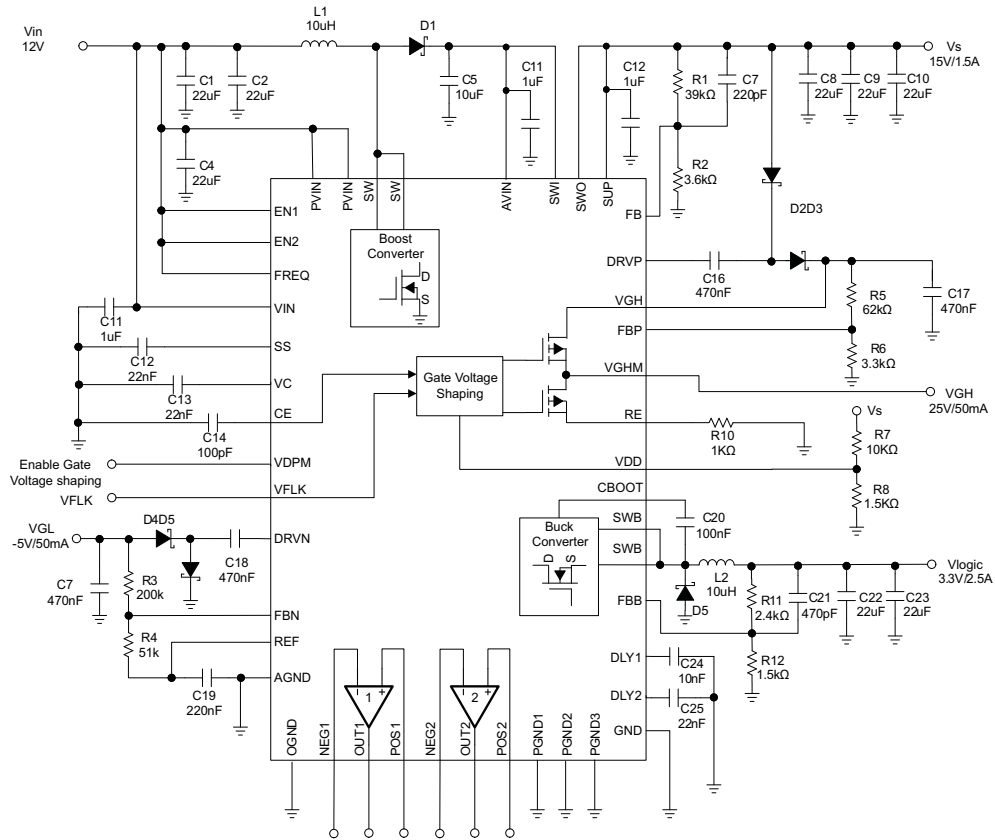

Figure 28. PCB Layout Recommendation TPS65162

TYPICAL APPLICATION



REVISION HISTORY

Changes from Revision A (March 2008) to Revision B	Page
• Changed list item from "8-V to 14.4-V Input Voltage Range" to "8-V to 14.7-V Input Voltage Range"	1
• Changed Input voltage range max from 14.4 to 14.7 V.	2
• Changed Input voltage range max from 14.4 to 14.7 V.	3
• Updated layout guidelines drawing.	28
• Updated typical application schematic.	29
<hr/>	
Changes from Revision B (June 2008) to Revision C	Page
• Changed Figure 21 , Q2 connection From: SUP To: SW1	17

TAPE AND REEL INFORMATION

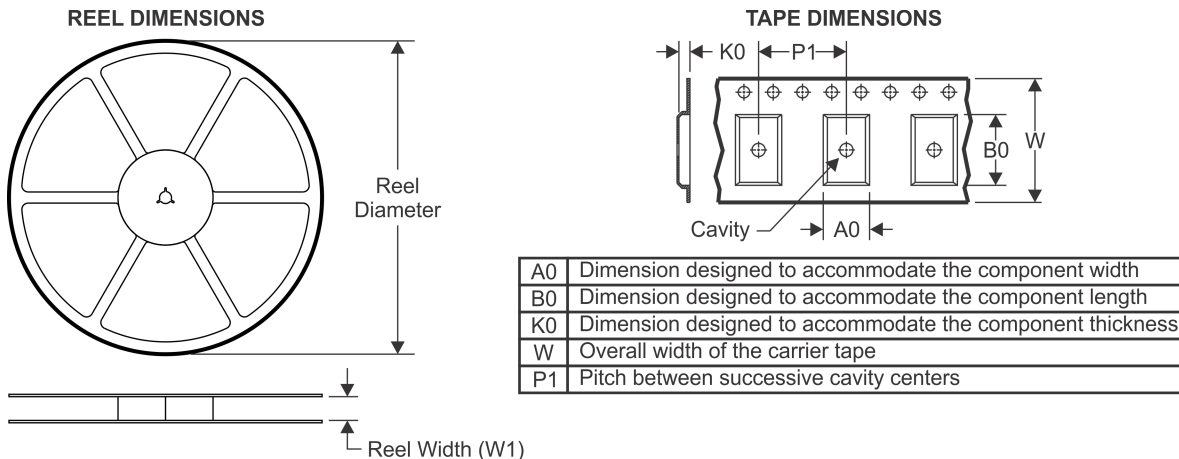

QUADRANT ASSIGNMENTS FOR PIN 1 ORIENTATION IN TAPE



*All dimensions are nominal

Device	Package Type	Package Drawing	Pins	SPQ	Reel Diameter (mm)	Reel Width W1 (mm)	A0 (mm)	B0 (mm)	K0 (mm)	P1 (mm)	W (mm)	Pin1 Quadrant
TPS65162RGZR	VQFN	RGZ	48	2500	330.0	16.4	7.3	7.3	1.1	12.0	16.0	Q2

TAPE AND REEL BOX DIMENSIONS

*All dimensions are nominal

Device	Package Type	Package Drawing	Pins	SPQ	Length (mm)	Width (mm)	Height (mm)
TPS65162RGZR	VQFN	RGZ	48	2500	367.0	367.0	38.0

GENERIC PACKAGE VIEW

RGZ 48

VQFN - 1 mm max height

7 x 7, 0.5 mm pitch

PLASTIC QUADFLAT PACK- NO LEAD

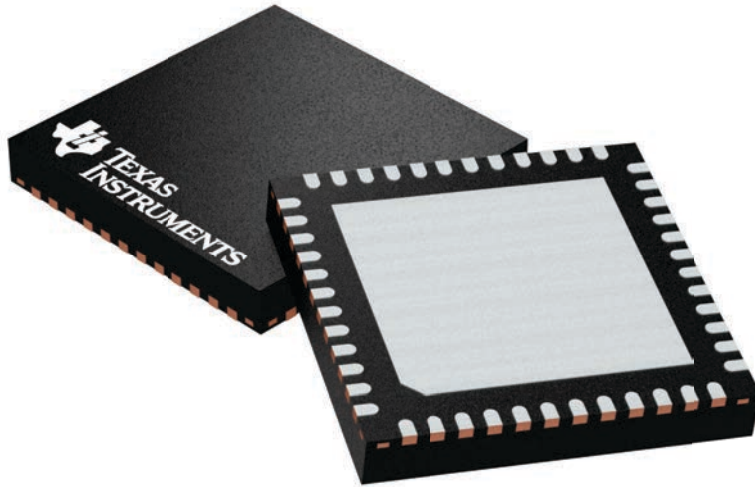

Images above are just a representation of the package family, actual package may vary.
Refer to the product data sheet for package details.

4224671/A

RGZ0048B

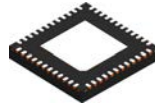

PACKAGE OUTLINE

VQFN - 1 mm max height

PLASTIC QUAD FLATPACK - NO LEAD

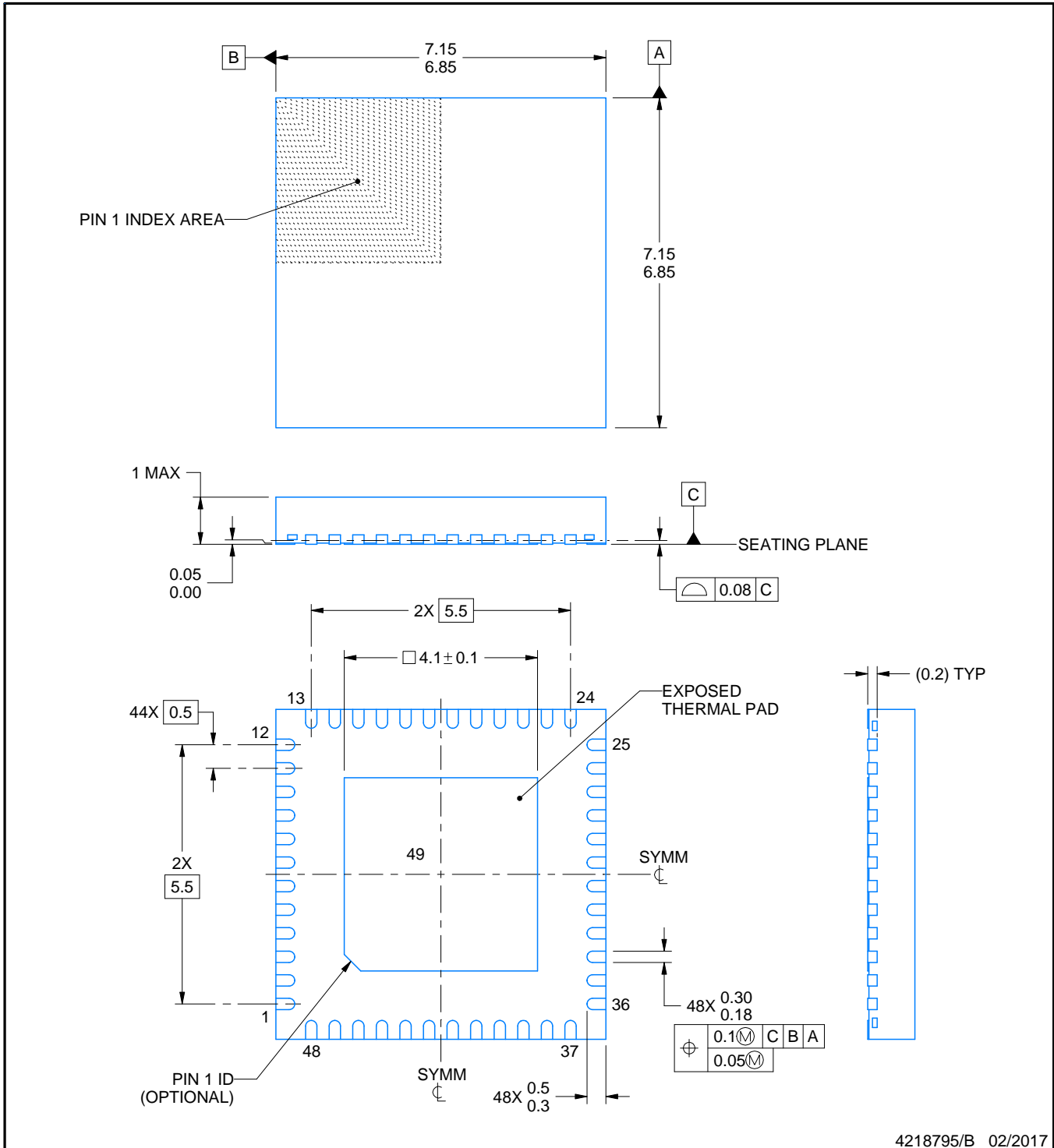

4218795/B 02/2017

NOTES:

1. All linear dimensions are in millimeters. Any dimensions in parenthesis are for reference only. Dimensioning and tolerancing per ASME Y14.5M.
2. This drawing is subject to change without notice.
3. The package thermal pad must be soldered to the printed circuit board for thermal and mechanical performance.

EXAMPLE BOARD LAYOUT

RGZ0048B

VQFN - 1 mm max height

PLASTIC QUAD FLATPACK - NO LEAD

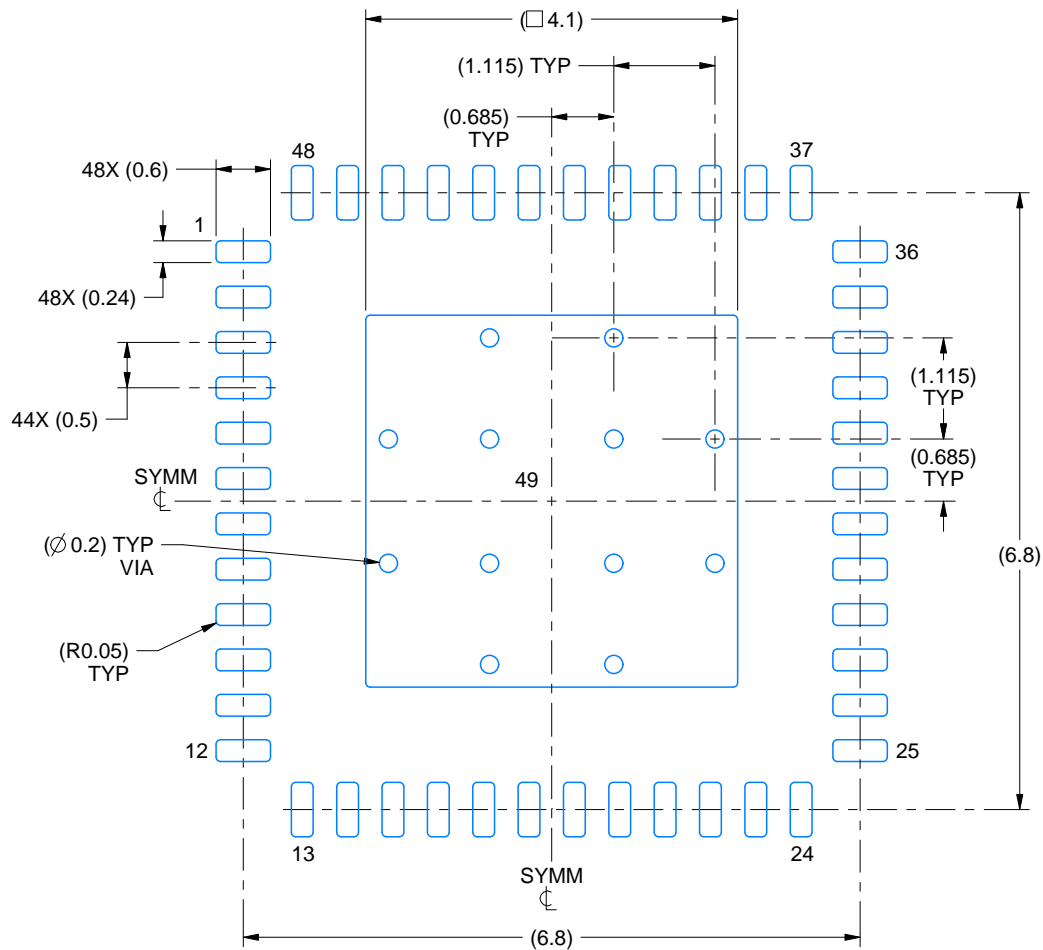

LAND PATTERN EXAMPLE
EXPOSED METAL SHOWN
SCALE:12X

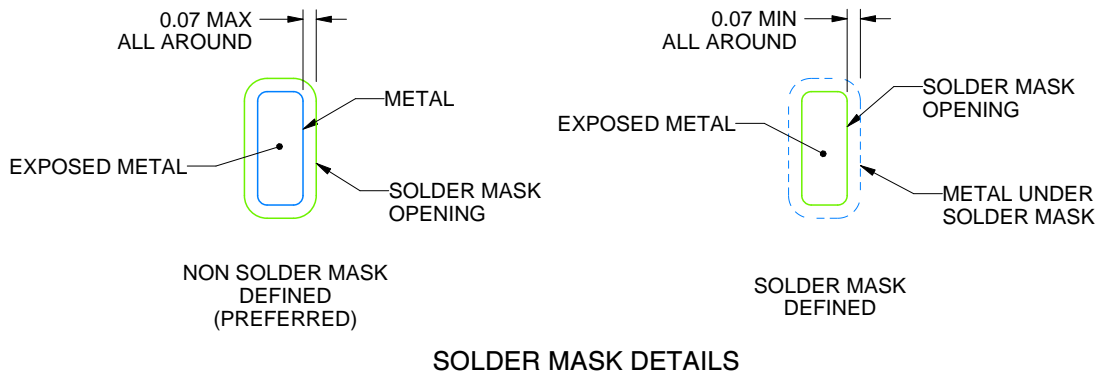

SOLDER MASK DETAILS

4218795/B 02/2017

NOTES: (continued)

4. This package is designed to be soldered to a thermal pad on the board. For more information, see Texas Instruments literature number SLUA271 (www.ti.com/lit/slua271).
5. Vias are optional depending on application, refer to device data sheet. If any vias are implemented, refer to their locations shown on this view. It is recommended that vias under paste be filled, plugged or tented.

EXAMPLE STENCIL DESIGN

RGZ0048B

VQFN - 1 mm max height

PLASTIC QUAD FLATPACK - NO LEAD

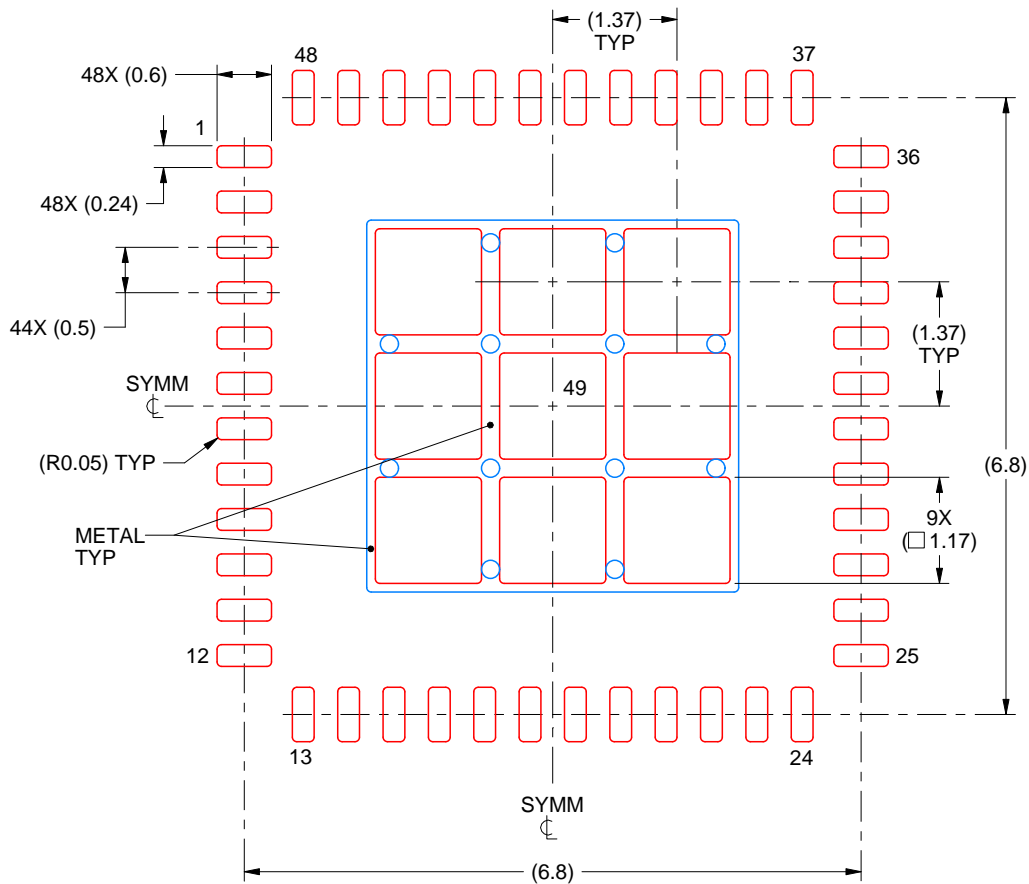

SOLDER PASTE EXAMPLE BASED ON 0.125 mm THICK STENCIL

EXPOSED PAD 49
73% PRINTED SOLDER COVERAGE BY AREA UNDER PACKAGE
SCALE:12X

4218795/B 02/2017

NOTES: (continued)

6. Laser cutting apertures with trapezoidal walls and rounded corners may offer better paste release. IPC-7525 may have alternate design recommendations.

IMPORTANT NOTICE AND DISCLAIMER

TI PROVIDES TECHNICAL AND RELIABILITY DATA (INCLUDING DATASHEETS), DESIGN RESOURCES (INCLUDING REFERENCE DESIGNS), APPLICATION OR OTHER DESIGN ADVICE, WEB TOOLS, SAFETY INFORMATION, AND OTHER RESOURCES "AS IS" AND WITH ALL FAULTS, AND DISCLAIMS ALL WARRANTIES, EXPRESS AND IMPLIED, INCLUDING WITHOUT LIMITATION ANY IMPLIED WARRANTIES OF MERCHANTABILITY, FITNESS FOR A PARTICULAR PURPOSE OR NON-INFRINGEMENT OF THIRD PARTY INTELLECTUAL PROPERTY RIGHTS.

These resources are intended for skilled developers designing with TI products. You are solely responsible for (1) selecting the appropriate TI products for your application, (2) designing, validating and testing your application, and (3) ensuring your application meets applicable standards, and any other safety, security, or other requirements. These resources are subject to change without notice. TI grants you permission to use these resources only for development of an application that uses the TI products described in the resource. Other reproduction and display of these resources is prohibited. No license is granted to any other TI intellectual property right or to any third party intellectual property right. TI disclaims responsibility for, and you will fully indemnify TI and its representatives against, any claims, damages, costs, losses, and liabilities arising out of your use of these resources.

TI's products are provided subject to TI's Terms of Sale (www.ti.com/legal/termsofsale.html) or other applicable terms available either on ti.com or provided in conjunction with such TI products. TI's provision of these resources does not expand or otherwise alter TI's applicable warranties or warranty disclaimers for TI products.

Mailing Address: Texas Instruments, Post Office Box 655303, Dallas, Texas 75265
Copyright © 2018, Texas Instruments Incorporated

Looking for pricing, stock, or lifecycle information?

Click below to explore more details on WIN SOURCE:

 [View TPS65162RGZRG4 on WIN SOURCE](#)

 [Texas Instruments](#) Information

Optimize Your Supply Chain with WIN SOURCE Solutions

-  Global Sourcing Solution
-  Obsolete Management
-  Cost Control Management
-  Shortage Management
-  Alternative Solution
-  Excess Inventory Management