



**THE DATASHEET OF
TPS65181RGZR**



TPS6518xx PMIC for E Ink® Vizplex™-Enabled Electronic Paper Display

1 Features

- Single-Chip Power Management Solution for E Ink® Vizplex™ Electronic Paper Displays
- Generates Positive and Negative Gate and Source Driver Voltages and Back-Plane Bias from a Single, Low-Voltage Input Supply
- 3-V to 6-V Input Voltage Range
- Boost Converter for Positive Rail Base
- Inverting Buck-Boost Converter for Negative Rail Base
- Two Adjustable LDOs for Source Driver Supply
 - LDO1: 15 V, 120 mA (VPOS)
 - LDO2: –15 V, 120 mA (VNEG)
- Accurate Output Voltage Tracking
 - VPOS - VNEG = ±50 mV
- Two Charge Pumps for Gate Driver Supply
 - CP1: 22 V, 10 mA (VDDH)
 - CP2: –20 V, 12 mA, (VEE)
- Adjustable VCOM Driver for Accurate Panel-Backplane Biasing
 - –0.3 V to –2.5 V
 - ±1.5% Accuracy (±18 mV)
 - 8-Bit Control (11-mV Nominal Step Size)
 - 15-mA Maximum Integrated Switch
- Integrated 3.3-V Power Switch for Disabling System Power Rail
- Thermistor Monitoring
 - –10°C to +85°C Temperature Range
 - ±1°C Accuracy from 0°C to 50°C
- I²C Serial Interface
 - Slave Address 0x48h (1001000)
- Flexible Power-Up Sequencing
- Interrupt and Sleep Mode Support
- Thermally-Enhanced Package for Efficient Heat Management (48-Pin 7 mm x 7 mm x 0.9 mm VQFN)

2 Applications

- Power Supply for Active Matrix E Ink Vizplex Panels
- EPD Power Supply
- E-Book Readers
- EPSON® S1D13522 (ISIS) Timing Controller
- EPSON S1D13521 (Broadsheet) Timing Controller
- Application Processors With Integrated or Software Timing Controller (OMAP™)

3 Description

The TPS6518x and TPS65181xB family of devices are single-chip power supplies designed to for E Ink Vizplex displays used in portable e-reader applications and support panel sizes up to 9.7 inches. Two high-efficiency DC–DC boost converters generate ±17-V rails which are boosted to 22 V and –20 V by two charge pumps to provide the gate driver supply for the Vizplex panel. Two tracking LDOs create the ±15-V source driver supplies which support up to 120-mA of output current. All rails are adjustable through the I²C interface to accommodate specific panel requirements.

Device Information⁽¹⁾

PART NUMBER	PACKAGE	BODY SIZE (NOM)
TPS65180 ⁽²⁾	VQFN (48)	7.00 mm x 7.00 mm
TPS65180B		
TPS65181 ⁽²⁾		
TPS65181B		

(1) For all available packages, see the orderable addendum at the end of the data sheet.

(2) Not recommended for new design (NRND).

Typical Application Schematic

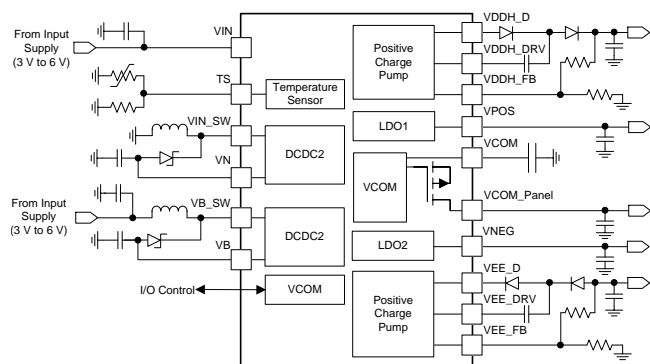

Table of Contents

1 Features	1	9.4 Device Functional Modes	17
2 Applications	1	9.5 Register Maps	18
3 Description	1	10 Application and Implementation	33
4 Revision History	2	10.1 Application Information	33
5 Description (continued)	3	10.2 Typical Application	41
6 Device Comparison Table	3	11 Power Supply Recommendations	42
7 Pin Configuration and Functions	4	12 Layout	43
8 Specifications	6	12.1 Layout Guidelines	43
8.1 Absolute Maximum Ratings	6	12.2 Layout Example	43
8.2 ESD Ratings	6	13 Device and Documentation Support	45
8.3 Recommended Operating Conditions	6	13.1 Device Support	45
8.4 Thermal Information	7	13.2 Documentation Support	45
8.5 Electrical Characteristics	8	13.3 Related Links	45
8.6 Data Transmission Timing	11	13.4 Community Resources	45
8.7 Typical Characteristics	11	13.5 Trademarks	45
9 Detailed Description	12	13.6 Electrostatic Discharge Caution	45
9.1 Overview	12	13.7 Glossary	46
9.2 Functional Block Diagram	13	14 Mechanical, Packaging, and Orderable Information	46
9.3 Feature Description	14		

4 Revision History

NOTE: Page numbers for previous revisions may differ from page numbers in the current version.

Changes from Revision F (February 2011) to Revision G	Page
<ul style="list-style-type: none"> Added <i>ESD Ratings</i> table, <i>Feature Description</i> section, <i>Device Functional Modes</i>, <i>Application and Implementation</i> section, <i>Power Supply Recommendations</i> section, <i>Layout</i> section, <i>Device and Documentation Support</i> section, and <i>Mechanical, Packaging, and Orderable Information</i> section. 	1

5 Description (continued)

Accurate back-plane biasing is provided by a linear amplifier and can be adjusted either by an external resistor or the I²C interface. The VCOM driver can source or sink current depending on panel condition. For automatic VCOM adjustment in production line, VCOM can be set from –0.3 V to –2.5 V with 8-bit control through the serial interface. The power switch is integrated to isolate VCOM driver from E Ink[®] panel.

The TPS6518x and TPS65181xB devices provide precise temperature measurement function to monitor the panel temperature during operation. The TPS65180 and TPS65180B requires the host processor to trigger the temperature acquisition through an I²C write whereas the TPS65181 and TPS65181B automatically updates the temperature every 60 s.

6 Device Comparison Table

FUNCTION	TPS65180 TPS65180B	TPS65181 TPS65181B
Compatibility	EPSON ISIS (S1D113522)	EPSON ISIS (S1D113522)
		EPSON Broadsheet (S1D13521)
	OMAP	OMAP
	ST	ST
Temperature sensor	Triggered by host	Automatically triggers every 60 s
I ² C interface	Standard	Supports standard and Broadsheet protocol
Fault recovery	INT register must be read before rails can be re-enabled after a fault	Interrupts are automatically reset when faults clear. No need to read INT register.
VCOM adjust default	I ² C control	External potentiometer

7 Pin Configuration and Functions

RGZ Package
48-Pin VQFN With Exposed Thermal Pad
Top View

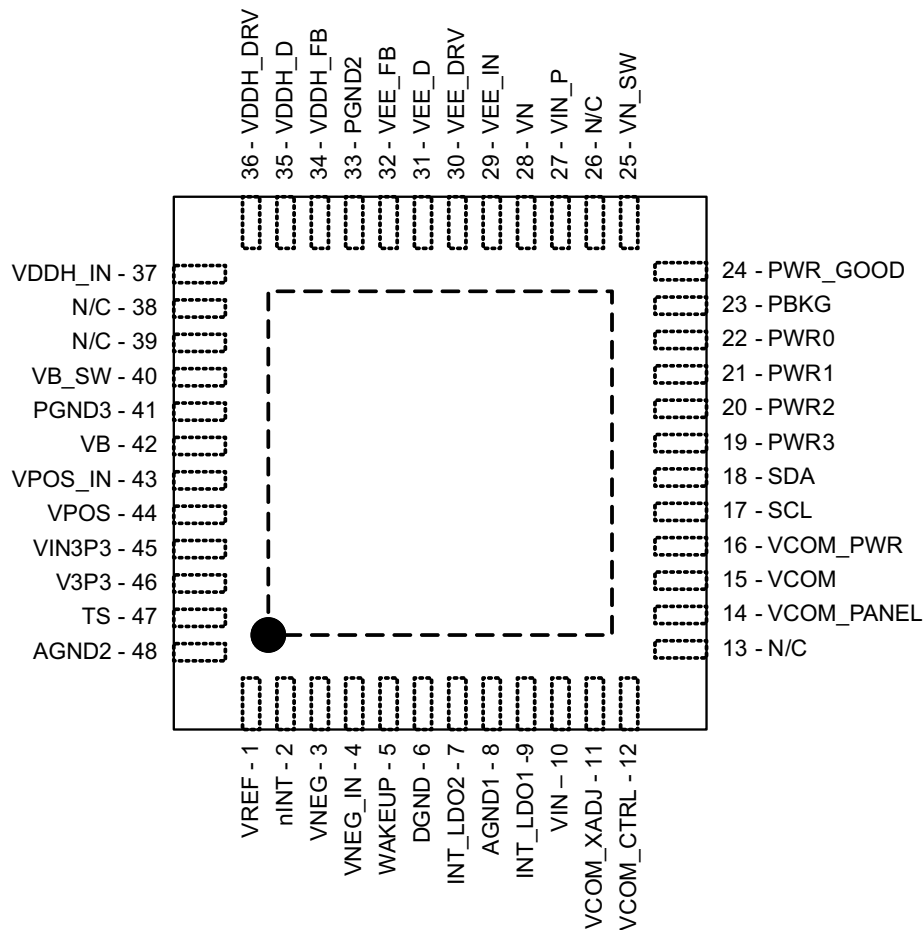

Pin Functions

PIN		I/O	DESCRIPTION
NO.	NAME		
1	VREF	O	Filter pin for 2.25-V internal reference to ADC
2	nINT	O	Open-drain interrupt pin (active low)
3	VNEG	O	Negative supply output pin for panel source drivers
4	VNEG_IN	I	Input pin for LDO2 (VNEG)
5	WAKEUP	I	Wake-up pin (active high). Pull this pin high to wake up from sleep mode.
6	DGND	—	Digital ground
7	INT_LDO2	O	Internal supply (digital circuitry) filter pin
8	AGND1	—	Analog ground for general analog circuitry
9	INT_LDO1	O	Internal supply (analog circuitry) filter pin
10	VIN	I	Input power supply to general circuitry
11	VCOM_XADJ	I	Analog input for conventional VCOM setup method. Tie this pin to ground if VCOM is set through I ² C interface.
12	VCOM_CTRL	I	VCOM_PANEL gate driver enable (active high)

Pin Functions (continued)

PIN		I/O	DESCRIPTION
NO.	NAME		
13	N/C	—	Not connected
14	VCOM_PANEL	O	Panel common-voltage output pin
15	VCOM	O	Filter pin for panel common-voltage driver
16	VCOM_PWR	I	Internal supply input pin to VCOM buffer. Connect to the output of DCDC2.
17	SCL	I	Serial interface (I ² C) clock input
18	SDA	I/O	Serial interface (I ² C) data input and output
19	PWR3	I	Enable pin for CP1 (VDDH) (active-high)
20	PWR2	I	Enable pin for LDO1 (VPOS) (active-high)
21	PWR1	I	Enable pin for CP2 (VEE) (active-high)
22	PWR0	I	Enable pin for LDO2 (VNEG) and VCOM (active-high)
23	PowerPAD (PBKG)	—	Die substrate/thermal pad. Connect to VN with short, wide trace. Wide copper trace improves heat dissipation. PowerPad must not be connected to ground.
24	PWR_GOOD	O	Open-drain power-good output pin (active-low)
25	VN_SW	O	Inverting buck-boost converter switch out (DCDC2)
26	N/C	—	Not connected
27	VIN_P	I	Input power supply to inverting buck-boost converter (DCDC2)
28	VN	I	Feedback pin for inverting buck-boost converter (DCDC2)
29	VEE_IN	I	Input supply pin for CP1 (VEE)
30	VEE_DRV	O	Driver output pin for negative charge pump (CP2)
31	VEE_D	O	Base voltage output pin for negative charge pump (CP2)
32	VEE_FB	I	Feedback pin for negative charge pump (CP2)
33	PGND2	—	Power ground for CP1 (VDDH) and CP2 (VEE) charge pumps
34	VDDH_FB	I	Feedback pin for positive charge pump (CP1)
35	VDDH_D	O	Base voltage output pin for positive charge pump (CP1)
36	VDDH_DRV	O	Driver output pin for positive charge pump (CP1)
37	VDDH_IN	I	Input supply pin for positive charge pump (CP1)
38	N/C	—	Not connected
39	N/C	—	Not connected
40	VB_SW	O	Boost converter switch out (DCDC1)
41	PGND3	—	Power ground for DCDC1
42	VB	I	Feedback pin for boost converter (DCDC1)
43	VPOS_IN	I	Input pin for LDO1 (VPOS)
44	VPOS	O	Positive supply output pin for panel source drivers
45	VIN3P3	I	Input pin to 3.3-V power switch
46	V3P3	O	Output pin of 3.3-V power switch
47	TS	I	Thermistor input pin. Connect a 10k NTC thermistor and a 43k linearization resistor between this pin and AGND2.
48	AGND2	—	Reference point to external thermistor and linearization resistor

8 Specifications

8.1 Absolute Maximum Ratings

 over operating free-air temperature range (unless otherwise noted) ⁽¹⁾⁽²⁾

	MIN	MAX	UNIT
Input voltage at VIN, VINP, VIN3P3	-0.3	7	V
Ground pins to system ground	-0.3	0.3	V
Voltage range at SDA, SCL, WAKEUP, PWR3, PWR2, PWR1, PWR0, VCOM_CTRL, VDDH_FB, VEE_FB, PWR_GOOD, nINT	-0.3	3.6	V
VCOM_XADJ	-3.6	0.3	V
Voltage on VB, VB_SW, VPOS_IN, VDDH_IN	-0.3	20	V
Voltage on VN, VNEG_IN, VEE_IN, VCOM_PWR	-20	0.3	V
Voltage from VINP to VN_SW	-0.3	30	V
Peak output current	Internally limited		mA
Continuous total power dissipation	2		W
T _J Operating junction temperature	-10	125	°C
T _A Operating ambient temperature ⁽³⁾	-10	85	°C
T _{stg} Storage temperature	-65	150	°C

- (1) Stresses beyond those listed under Absolute Maximum Ratings may cause permanent damage to the device. These are stress ratings only, and functional operation of the device at these or any other conditions beyond those indicated under Recommended Operating Conditions is not implied. Exposure to absolute maximum rated conditions for extended periods may affect device reliability.
- (2) All voltage values are with respect to network ground terminal.
- (3) TI recommends that copper plane in proper size on board be in contact with die thermal pad to dissipate heat efficiently. Thermal pad is electrically connected to PBKG, which is supposed to be tied to the output of buck-boost converter. Thus wide copper trace in the buck-boost output helps heat dissipated efficiently.

8.2 ESD Ratings

	VALUE	UNIT
V _(ESD) Electrostatic discharge	Human-body model (HBM), per ANSI/ESDA/JEDEC JS-001 ⁽¹⁾	±2000
	Charged-device model (CDM), per JEDEC specification JESD22-C101 ⁽²⁾	±500

- (1) JEDEC document JEP155 states that 500-V HBM allows safe manufacturing with a standard ESD control process.
- (2) JEDEC document JEP157 states that 250-V CDM allows safe manufacturing with a standard ESD control process.

8.3 Recommended Operating Conditions

over operating free-air temperature range (unless otherwise noted)

	MIN	NOM	MAX	UNIT
Input voltage at VIN, VINP, VIN3P3	3	3.7	6	V
Voltage at SDA, SCL, WAKEUP, PWR3, PWR2, PWR1, PWR0, VCOM_CTRL, VDDH_FB, VEE_FB, VCOM_XADJ, PWR_GOOD, nINT	0		3.6	V
T _A Operating ambient temperature	-10		85	°C
T _J Operating junction temperature	-10		125	°C

8.4 Thermal Information

THERMAL METRIC ⁽¹⁾		TPS6518x TPS6518xB	UNIT
		RGZ (VQFN)	
		48 PINS	
$R_{\theta JA}$	Junction-to-ambient thermal resistance ⁽²⁾	30.5	°C/W
$R_{\theta JC(top)}$	Junction-to-case (top) thermal resistance	16.2	°C/W
$R_{\theta JB}$	Junction-to-board thermal resistance	7.1	°C/W
Ψ_{JT}	Junction-to-top characterization parameter	0.2	°C/W
Ψ_{JB}	Junction-to-board characterization parameter	7.1	°C/W
$R_{\theta JC(bot)}$	Junction-to-case (bottom) thermal resistance	N/A	°C/W

- (1) For more information about traditional and new thermal metrics, see the *Semiconductor and IC Package Thermal Metrics* application report, [SPRA953](#).
- (2) Estimated when mounted on high K JEDEC board per JESD 51-7 with thickness of 1.6 mm, 4 layers, size of 76.2 mm x 114.3 mm, and 2-oz. copper for top and bottom plane. Actual thermal impedance depends on PCB used in the application.

8.5 Electrical Characteristics

 $V_{IN} = 3.7\text{ V}$, $T_A = -10^\circ\text{C}$ to 85°C , Typical values are at $T_A = 25^\circ\text{C}$ (unless otherwise noted)

PARAMETER		TEST CONDITIONS	MIN	TYP	MAX	UNIT
INPUT VOLTAGE						
V_{IN}	Input voltage range		3	3.7	6	V
V_{UVLO}	Undervoltage lockout threshold	V_{IN} falling		2.9		V
V_{HYS}	Undervoltage lockout hysteresis	V_{IN} rising		400		mV
INPUT CURRENT						
I_Q	Operating quiescent current into V_{IN}	Device switching, no load		5.5		mA
I_{STD}	Operating quiescent current into V_{IN}	Device in standby mode		130		μA
I_{SLEEP}	Shutdown current	Device in sleep mode		2.8	10	μA
INTERNAL SUPPLIES						
V_{INT_LDO1}	Internal supply			2.7		V
V_{INT_LDO2}	Internal supply			2.7		V
V_{REF}	Internal supply			2.25		V
DCDC1 (POSITIVE BOOST REGULATOR)						
V_{IN}	Input voltage range		3	3.7	6	V
V_{OUT}	Output voltage range			17		V
	DC set tolerance		-5%		5%	
I_{OUT}	Output current				160	mA
$R_{DS(ON)}$	MOSFET on resistance	$V_{IN} = 3.7\text{ V}$		350		$\text{m}\Omega$
I_{LIMIT}	Switch current limit			1.5		A
	Switch current accuracy		-30%		30%	
f_{SW}	Switching frequency			1		MHz
L	Inductor			2.2		μH
C	Capacitor			2 x 4.7		μF
ESR	Capacitor ESR			20		$\text{m}\Omega$
DCDC2 (INVERTING BUCK-BOOST REGULATOR)						
V_{IN}	Input voltage range		3	3.7	6	V
V_{OUT}	Output voltage range			-17		V
	DC set tolerance		-5%		5%	
I_{OUT}	Output current				160	mA
$R_{DS(ON)}$	MOSFET on resistance	$V_{IN} = 3.7\text{ V}$		350		$\text{m}\Omega$
I_{LIMIT}	Switch current limit			1.5		A
	Switch current accuracy		-30%		30%	
L	Inductor			4.7		μH
C	Capacitor			2 x 4.7		μF
ESR	Capacitor ESR			20		$\text{m}\Omega$
LDO1 (VPOS)						
V_{POS_IN}	Input voltage range		16.15	17	17.85	V
V_{SET}	Output voltage set value	$V_{IN} = 17\text{ V}$, $V_{POS_SET[2:0]} = 0x0h$ to $0x7h$	14.25	15	15.75	V
$V_{INTERVAL}$	Output voltage set resolution	$V_{IN} = 17\text{ V}$		250		mV
V_{POS_OUT}	Output voltage range	$V_{SET} = 15\text{ V}$, $I_{LOAD} = 20\text{ mA}$	14.85	15	15.15	V
V_{OUTTOL}	Output tolerance	$V_{SET} = 15\text{ V}$, $I_{LOAD} = 20\text{ mA}$	-1%		1%	
$V_{DROPOUT}$	Dropout voltage	$I_{LOAD} = 120\text{ mA}$			250	mV
$V_{LOADREG}$	Load regulation – DC	$I_{LOAD} = 10\%$ to 90%			1%	
I_{LOAD}	Load current range			120		mA

Electrical Characteristics (continued)
 $V_{IN} = 3.7\text{ V}$, $T_A = -10^\circ\text{C}$ to 85°C , Typical values are at $T_A = 25^\circ\text{C}$ (unless otherwise noted)

PARAMETER		TEST CONDITIONS	MIN	TYP	MAX	UNIT
I_{LIMIT}	Output current limit		200			mA
T_{SS}	Soft-start time			1		ms
C	Recommended output capacitor			4.7		μF
LDO2 (VNEG)						
V_{NEG_IN}	Input voltage range		-17.85	-17	-16.15	V
V_{SET}	Output voltage set value	$V_{IN} = -17\text{ V}$, $V_{NEG_SET[2:0]} = 0x0h$ to $0x7h$	-15.75	-15	-14.25	V
$V_{INTERVAL}$	Output voltage set resolution	$V_{IN} = -17\text{ V}$		250		mV
V_{NEG_OUT}	Output voltage range	$V_{SET} = -15\text{ V}$, $I_{LOAD} = -20\text{ mA}$	-15.15	-15	-14.85	V
V_{OUTTOL}	Output tolerance	$V_{SET} = -15\text{ V}$, $I_{LOAD} = -20\text{ mA}$	-1%		1%	
$V_{DROPOUT}$	Dropout voltage	$I_{LOAD} = 120\text{ mA}$			250	mV
$V_{LOADREG}$	Load regulation – DC	$I_{LOAD} = 10\%$ to 90%			1%	
I_{LOAD}	Load current range			120		mA
I_{LIMIT}	Output current limit		200			mA
T_{SS}	Soft-start time			1		ms
C	Recommended output capacitor			4.7		μF
LD01 (POS) AND LDO2 (VNEG) TRACKING						
V_{DIFF}	Difference between VPOS and VNEG	$V_{SET} = \pm 15\text{ V}$, $I_{LOAD} = \pm 20\text{ mA}$, 0°C to 60°C	-50		50	mV
VCOM DRIVER						
V_{COM}	Accuracy	$V_{COM_SET[7:0]} = 0x74h$ (-1.25 V) $V_{IN} = 3.4\text{ V}$ to 4.2 V , no load	-0.8%		0.8%	
		$V_{COM_SET[7:0]} = 0x74h$ (-1.25 V) $V_{IN} = 3.0\text{ V}$ to 6.0 V , no load	-1.5%		1.5%	
	Output voltage range		-2.5		-0.3	V
	Resolution	$V_{COM_ADJ} = 1\text{ V}$, 1 LSB		11		17
G	V_{COM} gain (V_{COM_XADJ}/V_{COM})	$V_{COM_ADJ} = 0\text{ V}$		1		V/V
VCOM SWITCH						
T_{ON}	Switch ON-time	$V_{COM} = -1.25\text{ V}$, $V_{COM_PANEL} = 0\text{ V}$ $C_{VCOM} = 4.7\text{ }\mu\text{F}$, $C_{VCOM_PANEL} = 4.7\text{ }\mu\text{F}$			1	ms
$R_{DS(ON)}$	MOSFET ON-resistance	$V_{COM} = -1.245\text{ V}$, $I_{COM} = 30\text{ mA}$		20	35	Ω
I_{LIMIT}	MOSFET current limit	Not tested in production		200		mA
I_{SWLEAK}	Switch leakage current	$V_{COM} = 0\text{ V}$, $V_{COM_PANEL} = -2.5\text{ V}$			8.3	nA
VIN3P3 TO V3P3 SWITCH						
$R_{DS(ON)}$	MOSFET ON-resistance	$V_{IN3P3} = 3.3\text{ V}$, $I_D = 2\text{ mA}$		50		Ω
CP1 (VDDH) CHARGE PUMP						
V_{DDH_IN}	Input voltage range		16.15	17	17.85	V
V_{FB}	Feedback voltage			1		V
	Accuracy		-3%		3%	
V_{DDH_OUT}	Output voltage range	$V_{SET} = 22\text{ V}$, $I_{LOAD} = 2\text{ mA}$	21	22	23	V
I_{LOAD}	Load current range				10	mA
f_{SW}	Switching frequency			560		KHz
C_D	Recommended driver capacitor			10		nF
C_O	Recommended output capacitor			4.7		μF
CP2 (VEE) NEGATIVE CHARGE PUMP						
V_{EE_IN}	Input voltage range		-17.75	-17	-16.15	V

Electrical Characteristics (continued)
 $V_{IN} = 3.7\text{ V}$, $T_A = -10^\circ\text{C}$ to 85°C , Typical values are at $T_A = 25^\circ\text{C}$ (unless otherwise noted)

PARAMETER		TEST CONDITIONS	MIN	TYP	MAX	UNIT
V_{FB}	Feedback voltage			-1		V
	Accuracy		-3%		3%	
V_{EE_OUT}	Output voltage range	$V_{SET} = -20\text{ V}$, $I_{LOAD} = 3\text{ mA}$	-21	-20	-19	V
I_{LOAD}	Load current range				12	mA
f_{SW}	Switching frequency			560		KHz
C_D	Recommended driver capacitor			10		nF
C_O	Recommended output capacitor			4.7		μF
THERMISTOR MONITOR⁽¹⁾						
A_{TMS}	Temperature to voltage ratio	Not tested in production		-0.0158		$V/^\circ\text{C}$
Offset _{TMS}	Offset	Temperature = 0°C		1.575		V
V_{TMS_HOT}	Temp hot trip voltage (T = 50°C)	TEMP_HOT_SET = 0x8C		0.768		V
V_{TMS_COOL}	Temp hot escape voltage (T = 45°C)	TEMP_COOL_SET = 0x82		0.845		V
V_{TMS_MAX}	Maximum input level			2.25		V
R_{NTC_PU}	Internal pullup resistor			7.307		k Ω
R_{LINEAR}	External linearization resistor			43		k Ω
ADC _{RES}	ADC resolution	Not tested in production, 1 bit		8.75		mV
ADC _{DEL}	ADC conversion time	Not tested in production		19		μs
TMST _{TOL}	Accuracy	Not tested in production	-2		2	LSB
LOGIC LEVELS AND TIMING CHARACTERISTICS (SCL, SDA, nINT, PWR_GOOD, PWRx, WAKEUP)						
V_{OL}	Output low threshold level	$I_O = 3\text{ mA}$, sink current (SDA, nINT, PWR_GOOD)			0.4	V
V_{IL}	Input low threshold level				0.4	V
V_{IH}	Input high threshold level		1.2			V
$I_{(bias)}$	Input bias current	$V_{IO} = 1.8\text{ V}$			1	μA
$t_{low,WAKEUP}$	WAKEUP low time	minimum low time for WAKEUP pin	150			ms
f_{SCL}	SCL clock frequency				400	KHz
OSCILLATOR						
f_{OSC}	Oscillator frequency			9		MHz
	Frequency accuracy	$T_A = -40^\circ\text{C}$ to 85°C	-10%		10%	
THERMAL SHUTDOWN						
T_{SHTDWN}	Thermal trip point			150		$^\circ\text{C}$
	Thermal hysteresis			20		$^\circ\text{C}$

(1) 10-k Ω Murata NCP18XH103F03RB thermistor (1%) in parallel with a linearization resistor (43 k Ω , 1%) are used at TS pin for panel temperature measurement.

8.6 Data Transmission Timing

 $V_{BAT} = 3.6\text{ V} \pm 5\%$, $T_A = 25^\circ\text{C}$, $C_L = 100\text{ pF}$ (unless otherwise noted)

		MIN	NOM	MAX	UNIT
$f_{(SCL)}$	Serial clock frequency	100		400	KHz
$t_{HD;STA}$	Hold time (repeated) START condition. After this period, the first clock pulse is generated.	SCL = 100 KHz	4		μs
		SCL = 400 KHz	600		ns
t_{LOW}	LOW period of the SCL clock	SCL = 100 KHz	4.7		μs
		SCL = 400 KHz	1.3		
t_{HIGH}	HIGH period of the SCL clock	SCL = 100 KHz	4		μs
		SCL = 400 KHz	600		ns
$t_{SU;STA}$	Set-up time for a repeated START condition	SCL = 100 KHz	4.7		μs
		SCL = 400 KHz	600		ns
$t_{HD;DAT}$	Data hold time	SCL = 100 KHz	0	3.45	μs
		SCL = 400 KHz	0	900	ns
$t_{SU;DAT}$	Data set-up time	SCL = 100 KHz	250		ns
		SCL = 400 KHz	100		
t_r	Rise time of both SDA and SCL signals	SCL = 100 KHz		1000	ns
		SCL = 400 KHz		300	
t_f	Fall time of both SDA and SCL signals	SCL = 100 KHz		300	ns
		SCL = 400 KHz		300	
$t_{SU;STO}$	Set-up time for STOP condition	SCL = 100 KHz	4		μs
		SCL = 400 KHz	600		ns
t_{BUF}	Bus free time between stop and start condition	SCL = 100 KHz	4.7		μs
		SCL = 400 KHz	1.3		
t_{SP}	Pulse width of spikes which must be suppressed by the input filter	SCL = 100 KHz	n/a	n/a	ns
		SCL = 400 KHz	0	50	

8.7 Typical Characteristics

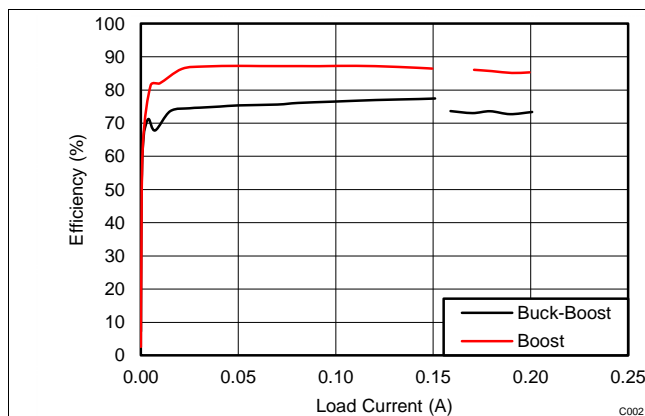

Figure 1. Efficiency vs Load Current

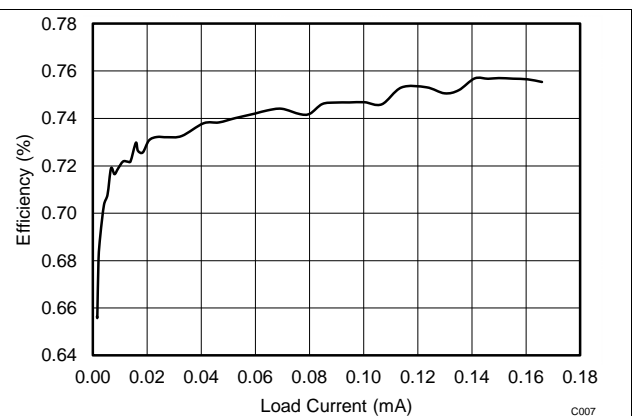

Figure 2. Load Current vs Efficiency

9 Detailed Description

9.1 Overview

The TPS6518x and TPS65181xB family of devices provides two adjustable LDOs, inverting buck-boost converter, boost converter, thermistor monitoring, and flexible power-up and power-down sequencing. The system can be supplied by a regulated input voltage ranging from 3 V to 6 V. The device is characterized across a -10°C to 85°C temperature range, best suited for personal electronic applications.

The I²C interface provides comprehensive features for using the TPS6518x and TPS65181xB family of devices. All rails can be enabled or disabled. Power-up and power-down sequences can also be programmed through the I²C interface, as well as thermistor and interrupt configurations. Voltage adjustment can also be controlled by the I²C interface. The adjustable LDOs can supply up to 120 mA of current. The default output voltages for each LDO can be adjusted through the I²C interface. LDO1 (VPOS) and LDO2 (VNEG) track each other in a way that they are of opposite sign but same magnitude. The sum of VLDO1 and VLDO2 is guaranteed to be less than 50 mV.

There are two charge pumps: VDDH and VEE 10 mA and 12 mA respectively. These charge pumps boost the DC-DC boost converters $\pm 16\text{-V}$ rails to provide a gate channel supply. The power-good functionality is open-drain output, if any of the four power rails (CP1, CP2, LDO1, LDO2) are not in regulation, encounters a fault, or is disabled the pin is pulled low. PWR_GOOD remains low if one of the rails is not enabled by the host and only after all rails are in regulation PWR_GOOD is released to Hi-Z state (pulled up by external resistor).

The TPS6518x and TPS65181xB family of devices provides circuitry to bias and measure an external NTC to monitor the display panel temperature in a range from -10°C to 85°C with an accuracy of $\pm 1^{\circ}\text{C}$ from 0°C to 50°C . Temperature measurements are triggered by the controlling host and the last temperature reading is always stored in the TMST_VALUE register.

Interrupts are issued when the temperature exceeds the programmable HOT, or drops below the programmable COLD threshold, or when the temperature has changed by more than a user-defined threshold from the baseline value.

9.2 Functional Block Diagram

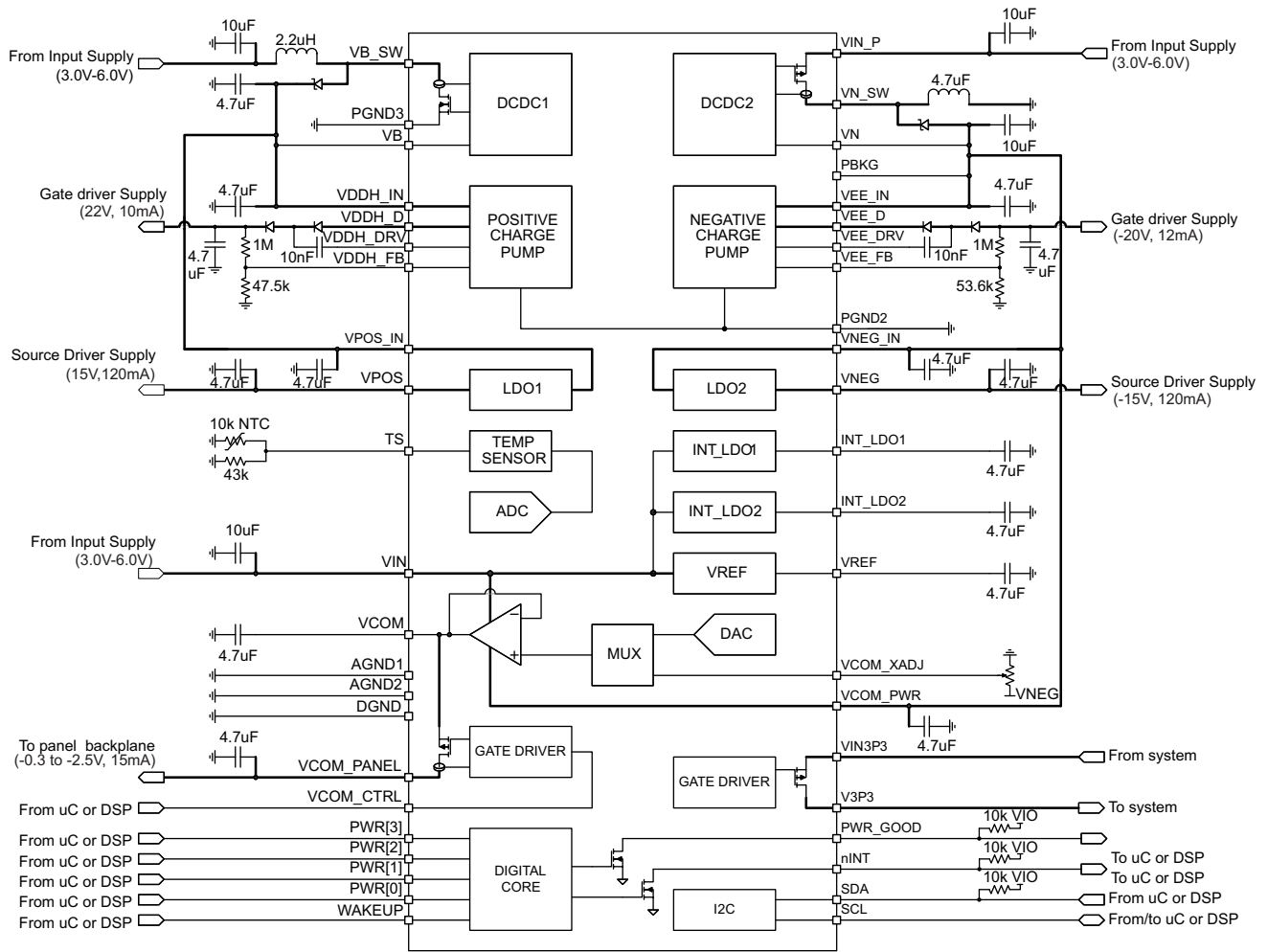

9.3 Feature Description

9.3.1 Modes of Operation

The TPS6518x and TPS65181xB have three modes of operation, SLEEP, STANDBY, and ACTIVE. SLEEP mode is the lowest-power mode in which all internal circuitry is turned off. In STANDBY, all power rails are shut down but the device is ready to accept commands through PWR[3:0] pins and/or I²C interface. In ACTIVE mode one or more power rails are enabled.

- SLEEP** This is the lowest power mode of operation. All internal circuitry is turned off, registers are reset to default values and the device does not respond to I²C communications. TPS6518x and TPS65181xB enter SLEEP mode whenever WAKEUP pin is pulled low.
- STANDBY** In STANDBY all internal support circuitry is powered up and the device is ready to accept commands either through GPIO or I²C control but none of the power rails are enabled. To enter STANDBY mode the WAKEUP pin must be pulled high and all PWRx pins must be pulled low or the STANDBY bit of the ENABLE register must be set high. The device also enters STANDBY mode if input undervoltage lockout (UVLO), positive boost undervoltage (VB_UV), or inverting buck-boost undervoltage (VN_UV) is detected, or thermal shutdown occurs.
- ACTIVE** The device is in ACTIVE mode when any of the output rails are enabled and no fault condition is present. This is the normal mode of operation while the device is powered up. In ACTIVE mode, a falling edge on any PWRx pin shuts down and a rising edge powers up the corresponding rail.

9.3.2 Mode Transitions

- SLEEP** → **ACTIVE** WAKEUP pin is pulled high (rising edge) with any PWRx pin high. Rails come up in the order defined by the PWR_SEQx registers.
- SLEEP** → **STANDBY** WAKEUP pin is pulled high (rising edge) with all PWRx pins low. Rails remain down until one or more PWRx pin is pulled high.
- ACTIVE** → **SLEEP** WAKEUP pin is pulled low (falling edge). Rails are shut down in the reverse power-up order defined by PWR_SEQ registers.
- ACTIVE** → **STANDBY** WAKEUP pin is high. All PWRx pins are pulled low (falling edge). Rails shut down in the order in which PWRx pins are pulled low. In the event of thermal shut down (TSD), undervoltage lockout (UVLO), positive boost or inverting buck-boost undervoltage (UV), or when STANDBY bit is set to 1, the device shuts down all rails in the reverse power-up order defined by the PWR_SEQx registers.
- STANDBY** → **ACTIVE** WAKEUP pin is high and any PWRx pin is pulled high (rising edge). Rails come up in the same order as PWRx pins are pulled high. Alternatively, if ACTIVE bit is set to 1, output rails power up in the order defined by the PWR_SEQx registers.
- STANDBY** → **SLEEP** WAKEUP pin is pulled low (falling edge) while none of the output rails are enabled.

Feature Description (continued)

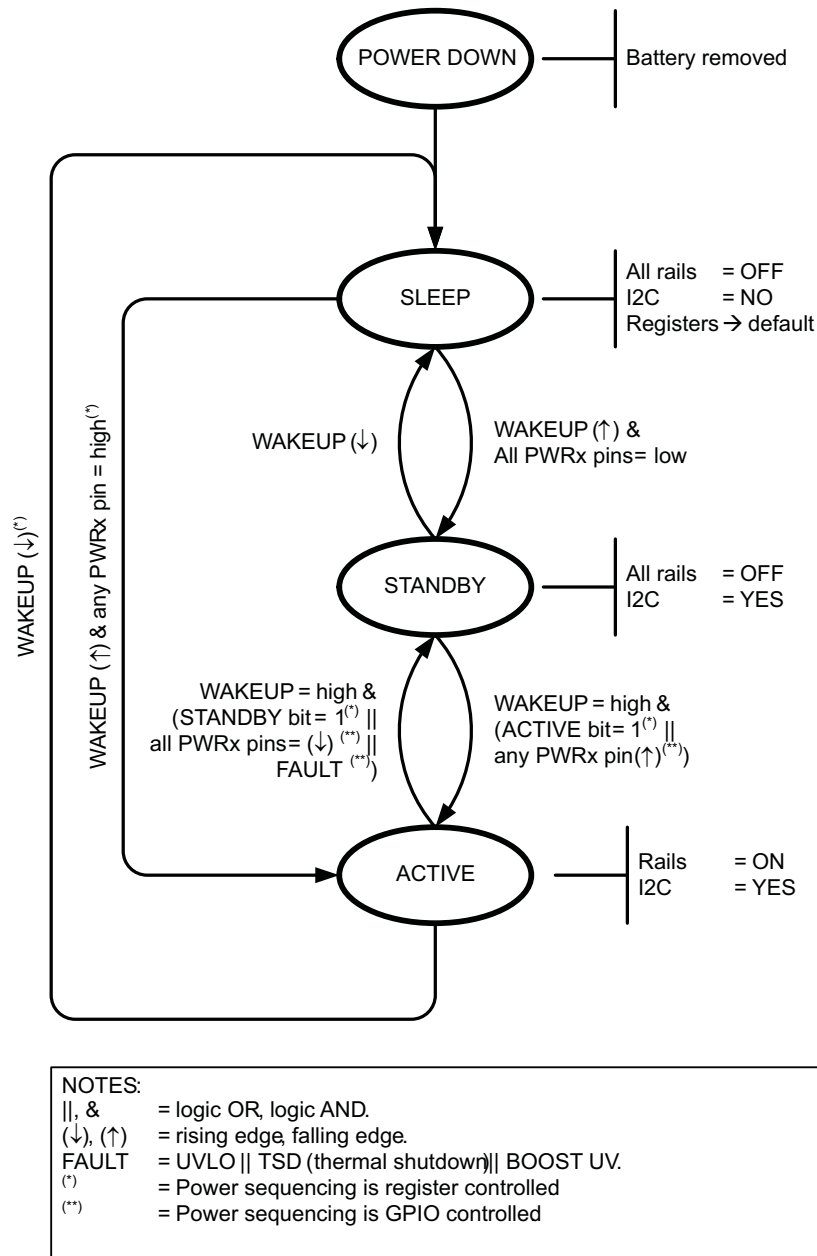

Figure 3. Global State Diagram

9.3.3 Wake-Up and Power Up Sequencing

The TPS6518x and TPS65181xB support flexible power-up sequencing through GPIO control using the PWR3, 2, 1, 0 pins or I²C control using the PWR_SEQ0, 1, 2 registers. Using GPIO control, the output rails are enabled/disabled in the order in which the PWRx pins are asserted or de-asserted, respectively, and the power-up timing is controlled by the host only.

In I²C control mode the power-up and power-down order and timing are defined by user register settings. The default settings support the E Ink Vizplex panel and typically do not need to be changed by the user.

Feature Description (continued)

9.3.4 GPIO Control

Under GPIO control the system host in E Ink Vizplex panel module enables the TPS6518x and TPS65181xB output rails by asserting the PWR0, PWR1, PWR2, PWR3 signals and the host has full control over the order and timing in which the output rails are powered up and down. Rails are in regulation 2 ms after their respective PWRx pin has been asserted with the exception of the first rail, which takes 6 ms to power up. The additional time is needed to power up the positive and inverting buck-boost regulator which need to be turned on before any other rail can be enabled. When all rails are enabled and in regulation the PWR_GOOD pin is released (pin status = Hi-Z and power-good line is pulled high by external pullup resistor). The PWRx pins are assigned to the rails as follows:

- PWR0: LDO2 (VNEG) and VCOM
- PWR1: CP2 (VEE)
- PWR2: LDO2 (VPOS)
- PWR3: CP1 (VDDH)

Rails are powered down whenever the host de-asserts the respective PWRx pin, and when all rails are disabled the device enters STANDBY mode. The next step is then to de-assert the WAKEUP pin to enter SLEEP mode which is the lowest-power mode of operation.

It is possible for the host to force the TPS6518x and TPS65181xB directly into SLEEP mode from ACTIVE mode by de-asserting the WAKEUP pin in which case the device follows the power-down sequence defined by the PWR_SEQx registers before entering SLEEP mode.

9.3.5 I²C Control

Under I²C control the power-up sequence is defined by the PWR_SEQx registers rather than through GPIO control. In SLEEP mode the TPS6518x and TPS65181xB are completely turned off, the I²C registers are reset, and the device does not accept any I²C transaction. Pull the WAKEUP pin high while all PWRx pins are held low and the device enters STANDBY mode which enables the I²C interface. Write to the PWR_SEQ0 register to define the order in which the output rails is enabled at power-up and to the PWR_SEQ1 and PWR_SEQ2 registers to define the power-up delays between rails. Finally, set the ACTIVE bit in the ENABLE register to 1 to execute the power-up sequence and bring up all power rails.

It is possible for the host to force the TPS6518x and TPS65181xB directly into ACTIVE mode from SLEEP mode by pulling the WAKEUP pin high while at least one of the PWRx pins is pulled high. In this case the default power-up sequence defined by the PWR_SEQx registers applies and the device starts powering up the rails 5.5 ms after the WAKEUP signal has been pulled high.

To power-down the device, set the STANDBY bit of the ENABLE register to 1 then the TPS6518x and TPS65181xB follows the reverse power-up sequence to bring down all power rails. While the sequencer is busy powering up the power rails, any activity on the PWRx pins is ignored. When all rails are up, any of the output rails can be disabled by applying a negative edge on the PWRx input pins, that is, if the host toggles the PWRx pin high-low or low-high-low, the respective rail is disabled regardless of how it has been enabled.

Feature Description (continued)

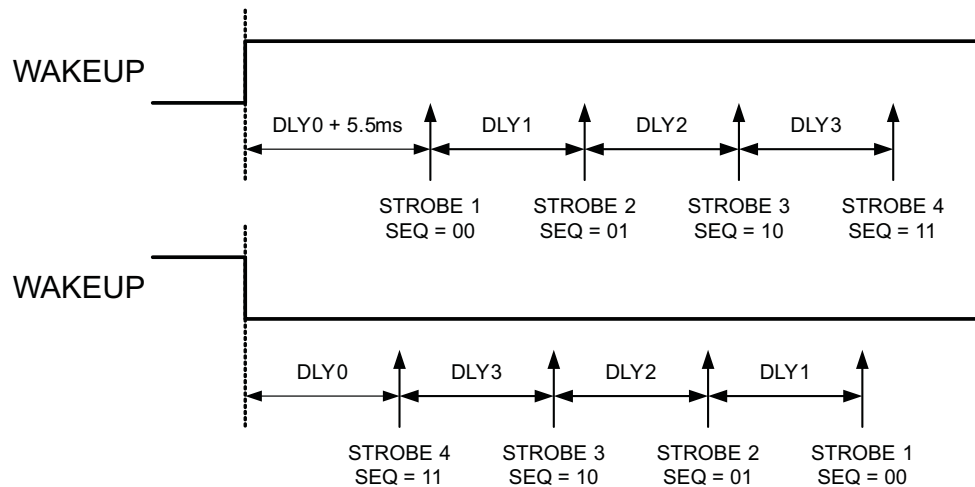

TOP: Power-up sequence is defined by assigning strobes to individual rails. STROBE1 is the first strobe to occur after WAKEUP has been pulled high and STROBE4 is the last event in the sequence. STROBES are assigned to rails in PWR_SEQ0 register and delays between states are defined in PWR_SEQ1 and PWR_SEQ2 registers.

BOTTOM: Power-down sequence follows reverse power-up sequence.

Figure 4. I²C Control

9.4 Device Functional Modes

9.4.1 The FIX_RD_PTR Bit

The TPS65181 and TPS65181B devices support a special I²C mode, making them compatible with the EPSON Broadsheet S1D13521 timing controller. Standard I²C protocol requires the following steps to read data from a register:

1. Send device slave address, R/nW bit set low (write command)
2. Send register address
3. Send device slave address, R/nW set high (read command)
4. The slave responds with data from the specified register address.

The EPSON Broadsheet S1D13521 controller does not support I²C writes nor I²C reads from addressed registers (step 1. and 2. above) but needs to access the temperature data from the TPS65181 or TPS65181B TMST_VALUE register. To support Broadsheet based systems, the TPS65181 and TPS65181B automatically trigger temperature acquisition every 60s and stores the result in TMST_VALUE register. With the FIX_RD_PTR bit in the FIX_RD_POINTER register set to 1 the device responds to any I²C read command with data from the TMST_VALUE register. No write command with the register address is required and address auto increment feature is disabled in this mode. Therefore reading the temperature data is reduced to two steps:

1. Send device address, R/nW set high (read command)
2. Read the data from the slave. The slave responds with data from TMST_VALUE register address.

Write functionality is not affected by the FIX_RD_PTR bit and the main controller in the system maintains full control of the PMIC. Interrupts and error flags are issued and need to be handled the same way as for the TPS65180 and TPS65180B with two exceptions:

1. The FIX_RD_PTR bit in the FIX_RD_POINTER register needs to be set to 0 before the main controller can read any register different from the TMST_VALUE register.
2. Thermal Shutdown (TSD), positive boost undervoltage (VB_UV), inverting buck-boost undervoltage (VN_UV), and input undervoltage lockout (UVLO) interrupt bits do not have to be cleared before output rails can be re-enabled.

Device Functional Modes (continued)

At system power-up the main processor sets up the PMIC by accessing the I²C registers and setting the control parameters as needed. When the system is setup correctly the main controller sets the FIX_READ_POINTER bit and the display controller can start accessing the temperature information. During normal operation the main controller can write to the PMIC at any time but before it can read access registers the FIX_READ_POINTER bit must be written 0.

9.5 Register Maps

Table 1. Register Address Map

REGISTER	ADDRESS (HEX)	NAME	DEFAULT VALUE	DESCRIPTION
0	0x00	TMST_VALUE	N/A	Thermistor value read by ADC
1	0x01	ENABLE	0001 1111	Enable/disable bits for regulators
2	0x02	VP_ADJUST	0010 0011	Voltage settings for VPOS, VDDH
3	0x03	VN_ADJUST	1010 0011	Voltage settings for VNEG, VEE
4	0x04	VCOM_ADJUST	0111 0100	Voltage settings for VCOM
5	0x05	INT_ENABLE1	0111 0100	Interrupt enable group1
6	0x06	INT_ENABLE2	1111 1011	Interrupt enable group2
7	0x07	INT_STATUS1	0xxx xx00	Interrupt status group1
8	0x08	INT_STATUS2	xxxx x0xx	Interrupt status group2
9	0x09	PWR_SEQ0	1110 0100	Power up sequence
10	0x0A	PWR_SEQ1	0010 0010	DLY0, DLY1 time set
11	0x0B	PWR_SEQ2	0010 0010	DLY2, DLY3 time set
12	0x0C	TMST_CONFIG	0010 0000	Thermistor configuration
13	0x0D	TMST_OS	0011 0010	Thermistor hot temp set
14	0x0E	TMST_HYST	0010 1101	Thermistor cool temp set
15	0x0F	PG_STATUS	0000 0000	Power-good status each rails
16	0x10	REVID	0100 0001	Device revision ID information
17	0x11	FIX_READ_POINTER	0000 0000	I ² C read pointer control

9.5.1 Thermistor Readout (TMST_VALUE) Register (Offset = 0x00h)

DATA BIT	D7	D6	D5	D4	D3	D2	D1	D0
FIELD NAME	TMST_VALUE[7:0]							
READ/WRITE	R	R	R	R	R	R	R	R
RESET VALUE	N/A	N/A	N/A	N/A	N/A	N/A	N/A	N/A

FIELD NAME	BIT DEFINITION
TMST_VALUE[7:0]	Temperature read-out 1111 0110 – < -10°C 1111 0110 – -10°C 1111 0111 – -9°C ... 1111 1110 – -2°C 1111 1111 – -1 °C 0000 0000 – 0 °C 0000 0001 – 1°C 0000 0010 – 2°C ... 0001 1001 – 25°C ... 0101 0101 – 85°C 0101 0101 – > 85°C

9.5.2 Enable (ENABLE) Register (Offset = 0x01h)

DATA BIT	D7	D6	D5	D4	D3	D2	D1	D0
FIELD NAME	ACTIVE	STANDBY	V3P3_SW_EN	VCOM_EN	VDDH_EN	VPOS_EN	VEE_EN	VNEG_EN
READ/WRITE	R/W	R/W	R/W	R/W	R/W	R/W	R/W	R/W
RESET VALUE	0	0	0	1	1	1	1	1

FIELD NAME	BIT DEFINITION ⁽¹⁾
ACTIVE	STANDBY to ACTIVE transition bit 1 – Transition from STANDBY to ACTIVE mode. Rails power up as defined by PWR_SEQx registers. 0 – No effect NOTE: After transition bit is cleared automatically.
STANDBY	ACTIVE to STANDBY transition bit 1 – Transition from ACTIVE to STANDBY mode. Rails power down as defined by PWR_SEQx registers. 0 – No effect NOTE: After transition bit is cleared automatically. STANDBY bit has priority over AVTIVE.
V3P3_SW_EN	VIN3P3 to V3P3 switch enable 1 – Switch is ON 0 – Switch id OFF
VCOM_EN	VCOM buffer enable 1 – Enabled 0 – Disabled
VDDH_EN	VDDH charge pump enable 1 – Enabled 0 – Disabled
VPOS_EN	VPOS LDO regulator enable 1 – Enabled 0 – Disabled NOTE: VPOS cannot be enabled before VNEG is enabled.
VEE_EN	VEE charge pump enable 1 – Enabled 0 – Disabled
VNEG_EN	VNEG LDO regulator enable 1 – Enabled 0 – Disabled NOTE: When VNEG is disabled VPOS is also disabled.

(1) Enable/disable bits for regulators are AND'd with PWRx signals.

9.5.3 Positive Voltage Rail Adjustment (VP_ADJUST) Register (Offset = 0x02h)

DATA BIT	D7	D6	D5	D4	D3	D2	D1	D0
FIELD NAME	Not used	VDDH_SET[2:0]			not used	VPOS_SET[2:0]		
READ/WRITE	R	R/W	R/W	R/W	R	R/W	R/W	R/W
RESET VALUE	0	0	1	0	0	0	1	1

FIELD NAME	BIT DEFINITION ⁽¹⁾
Not used	N/A
VDDH_SET[2:0]	VDDH voltage setting 000 – VDDH increase by 10% 001 – VDDH increase by 5% 010 – Nominal 011 – VDDH decrease by 5% 100 – VDDH decrease by 10% 101 – Reserved 110 – Reserved 111 – Reserved
Not used	N/A
VPOS_SET[2:0]	VPOS voltage setting 000 : VNEG - 0.75 V 001 : VNEG - 0.5 V 010 : VNEG - 0.25 V 011 : VNEG 100 : VNEG + 0.25 V 101 : VNEG + 0.5 V 110 : VNEG + 0.75 V 111 – Reserved NOTE: For proper tracking of the VPOS and VNEG supply these bits must remain set at their default value of 011b. VPOS tracks VNEG automatically when VNEG_SET[2:0] bits of VN_ADJUST register are changed.

(1) VDDH is decreased from set value defined by resistor divider. Decreased VDDH value must be within spec range.

9.5.4 Negative Voltage Rail Adjustment (VN_ADJUST) Register (Offset = 0x03h)

DATA BIT	D7	D6	D5	D4	D3	D2	D1	D0
FIELD NAME	VCOM_ADJ	VEE_SET[2:0]			Not used	VNEG_SET[2:0]		
READ/WRITE	R/W	R/W	R/W	R/W	R	R/W	R/W	R/W
RESET VALUE	1 ⁽¹⁾	0	1	0	0	0	1	1

(1) TPS65180/TPS65180B: Bit defaults to 1; TPS65181/TPS65181B: Bit defaults to 0

FIELD NAME	BIT DEFINITION
VCOM_ADJ	VCOM output adjustment method 0 – VCOM_XADJ pin 1 – I ² C interface
VEE_SET[2:0] ⁽¹⁾	VDDH voltage setting 000 – VEE decrease by 10% 001 – VEE decrease by 5% 010 – Nominal 011 – VEE increase by 5% 100 – VEE increase by 10% 101 – Reserved 110 – Reserved 111 – Reserved
not used	N/A
VNEG_SET[2:0]	VNEG voltage setting 000 – -15.75 V 001 – -15.50 V 010 – -15.25 V 011 – -15.00 V 100 – -14.75 V 101 – -14.50 V 110 – -14.25 V 111 – Reserved

(1) VEE is decreased from set value defined by resistor divider. Decreased VEE value must be within spec range.

9.5.5 VCOM Adjustment (VCOM_ADJUST) Register (Offset = 0x04h)

DATA BIT	D7	D6	D5	D4	D3	D2	D1	D0
FIELD NAME	VCOM_SET[7:0]							
READ/WRITE	R/W	R/W	R/W	R/W	R/W	R/W	R/W	R/W
RESET VALUE	0	1	1	1	0	1	0	0

FIELD NAME	BIT DEFINITION
VCOM_SET[7:0]	VCOM voltage adjustment 0000 0000 – 0 V 0000 0001 – 11 mV 0000 0010 – 22 mV ... 0111 0011 – 1239 mV 0111 0100 – 1250 mV 0111 0101 – 1261 mV ... 1111 1111 – 2750 mV NOTE: step size is rounded to 11 mV. Theoretical step size is 2750 mV / 255 mV = 10.78 mV. Parametric performance is guaranteed from -0.3 V to -2.5 V only.

9.5.6 Interrupt Enable 1 (INT_ENABLE1) Register (Offset = 0x05h)

DATA BIT	D7	D6	D5	D4	D3	D2	D1	D0
FIELD NAME	Not used	TSD_EN	HOT_EN	TMST_HOT_EN	TMST_COOL_EN	UVLO_EN	Not used	Not used
READ/WRITE	R	R/W	R/W	R/W	R/W	R/W	R	R
RESET VALUE	0	1	1	1	0	1	0	0

FIELD NAME	BIT DEFINITION
Not used	N/A
TSD_EN	Thermal shutdown interrupt enable 1 – Enabled 0 – Disabled
HOT_EN	Thermal shutdown early warning enable 1 – Enabled 0 – Disabled
TMST_HOT_EN	Thermistor hot warning enable 1 – Enabled 0 – Disabled
TMST_COOL_EN	Thermistor hot escape interrupt enable 1 – Enabled 0 – Disabled
UVLO_EN	VIN undervoltage detect interrupt enable 1 – Enabled 0 – Disabled
Not used	N/A
Not used	N/A

9.5.7 Interrupt Enable 2 (INT_ENABLE2) Register (Offset = 0x06h)

DATA BIT	D7	D6	D5	D4	D3	D2	D1	D0
FIELD NAME	VB_UV_EN	VDDH_UV_EN	VN_UV_EN	VPOS_UV_EN	VEE_UV_EN	not used	VNEG_UV_EN	EOC_EN
READ/WRITE	R/W	R/W	R/W	R/W	R/W	R	R/W	R/W
RESET VALUE	1	1	1	1	1	0	1	1

FIELD NAME	BIT DEFINITION
VB_UV_EN	Positive boost converter undervoltage detect interrupt enable 1 – Enabled 0 – Disabled
VDDH_UV_EN	VDDH undervoltage detect interrupt enable 1 – Enabled 0 – Disabled
VN_UV_EN	Inverting buck-boost converter undervoltage detect interrupt enable 1 – Enabled 0 – Disabled
VPOS_UV_EN	VPOS undervoltage detect interrupt enable 1 – Enabled 0 – Disabled
VEE_UV_EN	VEE undervoltage detect interrupt enable 1 – Enabled 0 – Disabled
not used	N/A
VNEG_UV_EN	VNEG undervoltage detect interrupt enable 1 – Enabled 0 – Disabled
EOC_EN	ADC end of conversion interrupt enable 1 – Enabled 0 – Disabled

9.5.8 Interrupt INT_STATUS1 (INT_STATUS1) Register (Offset = 0x07h)

DATA BIT	D7	D6	D5	D4	D3	D2	D1	D0
FIELD NAME	Not used	TSDN	HOT	TMST_HOT	TMST_COOL	UVLO	Not used	Not used
READ/WRITE	R	R	R	R	R	R	R	R
RESET VALUE	0	N/A	N/A	N/A	N/A	N/A	0	0

FIELD NAME	BIT DEFINITION
Not used	N/A
TSD	Thermal shutdown interrupt
HOT	Thermal shutdown early warning
TMST_HOT	Thermistor hot warning
TMST_COOL	Thermistor hot escape interrupt
UVLO	VIN undervoltage detect interrupt
Not used	N/A
Not used	N/A

9.5.9 Interrupt Status 2 (INT_STATUS2) Register (Offset = 0x08h)

DATA BIT	D7	D6	D5	D4	D3	D2	D1	D0
FIELD NAME	VB_UV	VDDH_UV	VN_UV	VPOS_UV	VEE_UV	Not used	VNEG_UV	EOC
READ/WRITE	R	R	R	R	R	R	R	R
RESET VALUE	N/A	N/A	N/A	N/A	N/A	0	N/A	N/A

FIELD NAME	BIT DEFINITION ⁽¹⁾
VB_UV	Positive boost converter undervoltage detect interrupt
VDDH_UV	VDDH undervoltage detect interrupt
VN_UV	Inverting buck-boost converter undervoltage detect interrupt
VPOS_UV	VPOS undervoltage detect interrupt
VEE_UV	VEE undervoltage detect interrupt
not used	N/A
VNEG_UV	VNEG undervoltage detect interrupt
EOC	ADC end of conversion interrupt

(1) Undervoltage detect bit is set if the corresponding rail does not come up 5 ms after it is enabled except for DCDC1 and 2 which are set 10 ms after they are enabled.

9.5.10 Power Sequence Register 0 (PWR_SEQ0) Register (Offset = 0x09h)

DATA BIT	D7	D6	D5	D4	D3	D2	D1	D0
FIELD NAME	VDDH_SEQ[1:0]		VPOS_SEQ[1:0]		VEE_SEQ[1:0]		VNEG_SEQ[1:0]	
READ/WRITE	R/W	R/W	R/W	R/W	R/W	R/W	R/W	R/W
RESET VALUE	1	1	1	0	0	1	0	0

FIELD NAME	BIT DEFINITION ⁽¹⁾
VDDH_SEQ[1:0]	VDDH power-up/down order 00 – Power-up/down on STROBE1 01 – Power-up/down on STROBE2 10 – Power-up/down on STROBE3 11 – Power-up/down on STROBE4
VPOS_SEQ[1:0]	VPOS power-up/down order 00 – Power-up/down on STROBE1 01 – Power-up/down on STROBE2 10 – Power-up/down on STROBE3 11 – Ppower-up/down on STROBE4
VEE_SEQ[1:0]	VEE power-up/down order 00 – Power-up/down on STROBE1 01 – Power-up/down on STROBE2 10 – Power-up/down on STROBE3 11 – Power-up/down on STROBE4
VNEG_SEQ[1:0]	VNEG power-up/down order 00 – Power-up/down on STROBE1 01 – Power-up/down on STROBE2 10 – Power-up/down on STROBE3 11 – Power-up/down on STROBE4

(1) Power-down sequence follows the reverse order of power-up.

9.5.11 Power Sequence Register 1 (PWR_SEQ1) Register (Offset = 0x0Ah)

DATA BIT	D7	D6	D5	D4	D3	D2	D1	D0
FIELD NAME	DLY1[3:0]				DLY0[3:0]			
READ/WRITE	R/W	R/W	R/W	R/W	R/W	R/W	R/W	R/W
RESET VALUE	0	0	1	0	0	0	1	0

FIELD NAME	BIT DEFINITION
DLY1[3:0]	DLY1 delay time set; defines the delay time from STROBE1 to STROBE2 during power-up and from STROBE2 to STROBE1 during power-down. 0000 – 0 ms 0001 – 1 ms 0010 – 2 ms 0011 – 3 ms ... 1110 – 14 ms 1111 – 15 ms
DLY0[3:0]	DLY0 delay time set; defines the delay time from WAKEUP high to STROBE1 during power-up and from WAKEUP low to STROBE4 during power-down. 0000 – 0 ms 0001 – 1 ms 0010 – 2 ms 0011 – 3 ms ... 1110 – 14 ms 1111 – 15 ms

9.5.12 Power Sequence Register 2 (PWR_SEQ2) Register (Offset = 0x0Bh)

DATA BIT	D7	D6	D5	D4	D3	D2	D1	D0
FIELD NAME	DLY3[3:0]				DLY2[3:0]			
READ/WRITE	R/W	R/W	R/W	R/W	R/W	R/W	R/W	R/W
RESET VALUE	0	0	1	0	0	0	1	0

FIELD NAME	BIT DEFINITION
DLY3[3:0]	DLY3 delay time set; defines the delay time from STROBE3 to STROBE4 during power-up and from STROBE4 to STROBE3 during power-down. 0000 – 0 ms 0001 – 1 ms 0010 – 2 ms 0011 – 3 ms ... 1110 – 14 ms 1111 – 15 ms
DLY2[3:0]	DLY2 delay time set; defines the delay time from STROBE2 to STROBE3 during power-up and from STROBE3 to STROBE2 during power-down. 0000 – 0 ms 0001 – 1 ms 0010 – 2 ms 0011 – 3 ms ... 1110 – 14 ms 1111 – 15 ms

9.5.13 Thermistor Configuration Register (TMST_CONFIG) (Offset = 0x0Ch)

DATA BIT	D7	D6	D5	D4	D3	D2	D1	D0
FIELD NAME	READ_THERM	Not used	CONV_END	FAULT_QUE [1:0]		FAULT_QUE_CLR	Not used	Not used
READ/WRITE	R/W	R	R	R/W	R/W	R/W	R	R
RESET VALUE	0	0	1	0	0	0	0	0

FIELD NAME	BIT DEFINITION
READ_THERM	Read thermistor value 1 – Initiates temperature acquisition 0 – No effect NOTE: bit is self-cleared after acquisition is completed
Not used	N/A
CONV_END	ADC conversion done flag 1 – Conversion is finished 0 – Conversion is not finished
FAULT_QUE [1:0]	Number of faults to detect before TMST_HOT interrupt is asserted 00 – 1 time 01 – 2 times 10 – 4 times 11 – 6 times
FAULT_QUE_CLR	Fault counter clear 1 – Clears fault counter 0 – Fault counter is cleared automatically if thermistor reading is less than TMST_HOT_SET[7:0]
Not used	N/A
Not used	N/A

9.5.14 Thermistor Hot Threshold (TMST_OS) Register (Offset = 0x0Dh)

DATA BIT	D7	D6	D5	D4	D3	D2	D1	D0
FIELD NAME	TMST_HOT_SET[7:0]							
READ/WRITE	R/W	R/W	R/W	R/W	R/W	R/W	R/W	R/W
RESET VALUE	0	0	1	1	0	0	1	0

FIELD NAME	BIT DEFINITION
TMST_HOT_SET[7:0]	Defined the thermistor HOT threshold
	1000 0000 – Reserved
	...
	1111 0101 – Reserved
	1111 0110 – -10°C
	1111 0111 – -9°C
	...
	1111 1110 – -2°C
	1111 1111 – -1°C
	0000 0000 – 0°C
	0000 0001 – 1°C
	0000 0010 – 2°C
	...
	0001 1001 – 25°C
	...
	0011 0010 – 50°C
	...
0101 0101 – 85°C	
0101 0110 – Reserved	
...	
0111 1111 – Reserved	

9.5.15 Thermistor Cool Threshold (TMST_HYST) Register (Offset = 0x0Eh)

DATA BIT	D7	D6	D5	D4	D3	D2	D1	D0
FIELD NAME	TMST_COOL_SET[7:0]							
READ/WRITE	R/W	R/W	R/W	R/W	R/W	R/W	R/W	R/W
RESET VALUE	0	0	1	0	1	1	0	1

FIELD NAME	BIT DEFINITION
TMST_HOT_SET[7:0]	Defined the thermistor HOT threshold
	1000 0000 – Reserved
	...
	1111 0101 – Reserved
	1111 0110 – -10°C
	1111 0111 – -9°C
	...
	1111 1110 – -2°C
	1111 1111 – -1°C
	0000 0000 – 0°C
	0000 0001 – 1°C
	0000 0010 – 2°C
	...
	0001 1001 – 25°C
	...
	0010 1101 – 45°C
	...
0101 0101 – 85°C	
0101 0110 – Reserved	
...	
0111 1111 – Reserved	

9.5.16 Power-Good Status (PG_STATUS) Register (Offset = 0x0Fh)

DATA BIT	D7	D6	D5	D4	D3	D2	D1	D0
FIELD NAME	VB_PG	VDDH_PG	VN_PG	VPOS_PG	VEE_PG	Not used	VNEG_PG	Not used
READ/WRITE	R	R	R	R	R	R	R	R
RESET VALUE	0	0	0	0	0	0	0	0

FIELD NAME	BIT DEFINITION
VB_PG	Positive boost converter power-good
VDDH_PG	VDDH power-good
VN_PG	Inverting buck-boost power-good
VPOS_PG	VPOS power-good
VEE_PG	VEE power-good
not used	N/A
VNEG_PG	VNEG power-good
not used	N/A

9.5.17 Revision and Version Control (REVID) Register (Offset = 0x10h)

DATA BIT	D7	D6	D5	D4	D3	D2	D1	D0
FIELD NAME	REVID[7:0]							
READ/WRITE	R	R	R	R	R	R	R	R
RESET VALUE	0	1	1	1	0	0	0	0

FIELD NAME	BIT DEFINITION
REVID [7:0]	0101 0000 - TPS65180 1p1 0110 0000 - TPS65180 1p2 0111 0000 - TPS65180B (TPS65180 1p3) 1000 0000 - TPS65180B (TPS65180 1p4) 0101 0001 - TPS65181 1p1 0110 0001 - TPS65181 1p2 0111 0001 - TPS65181B (TPS65181 1p3) 1000 0001 - TPS65181B (TPS65181 1p4)

9.5.18 I²C Read Pointer Control (FIX_READ_POINTER) Register (Offset = 0x11h) (TPS65181 and TPS65181B ONLY)

DATA BIT	D7	D6	D5	D4	D3	D2	D1	D0
FIELD NAME	Not used	Not used	Not used	Not used	Not used	Not used	Not used	FIX_RD_PTR
READ/WRITE	R	R	R	R	R	R	R	R/W
RESET VALUE	0	0	0	0	0	0	0	0

FIELD NAME	BIT DEFINITION
Not used	N/A
Not used	N/A
Not used	N/A
Not used	N/A
Not used	N/A
Not used	N/A
Not used	N/A
FIX_RD_PTR	I ² C read pointer control 1 – Read pointer is fixed to 0x00 0 – read pointer is controlled through I ² C

10 Application and Implementation

NOTE

Information in the following applications sections is not part of the TI component specification, and TI does not warrant its accuracy or completeness. TI's customers are responsible for determining suitability of components for their purposes. Customers should validate and test their design implementation to confirm system functionality.

10.1 Application Information

10.1.1 Dependencies Between Rails

Charge pumps, LDOs, and VCOM driver are dependent on the positive and inverting buck-boost converters and several dependencies exist that affect the power-up sequencing. These dependencies are listed as follows:

1. Inverting buck-boost (DCDC2) must be in regulation before positive boost (DCDC1) can be enabled. Internally, DCDC1 enable is gated by DCDC2 power-good.
2. Positive boost (DCDC1) must be in regulation before LDO2 (VNEG) can be enabled. Internally LDO2 enable is gated DCDC1 power-good.
3. Positive boost (DCDC1) must be in regulation before VCOM can be enabled; Internally VCOM enable is gated by DCDC1 power-good.
4. Positive boost (DCDC1) must be in regulation before negative charge pump (CP2) can be enabled. Internally CP2 enable is gated by DCDC1 power-good.
5. Positive boost (DCDC1) must be in regulation before positive charge pump (CP1) can be enabled. Internally CP1 enable is gated by DCDC1 power-good.
6. LDO2 must be in regulation before LDO1 can be enabled. Internally LDO1 enable is gated by LDO2 power-good.
7. The minimum delay time between any two PWRx pins must be $> 62.5 \mu\text{s}$ in order to follow the power up sequence defined by GPIO control. If any two PWRx pins are pulled up together ($< 62.5 \mu\text{s}$ apart) or the sequencer tries to bring up the rails at the same time by assigning the same STROBE to rails in PWR_SEQ0 register, rails is staggered in a manner that an enable of the subsequent rail is gated by PG of a preceding rail. In this case, the default order of power-up is LDO2 (VNEG), CP2 (VEE), LDO1 (VPOS), and CP1(VDDH). If any two PWRx pins are pulled low together or the sequencer tries to bring down the rails at the same time by assigning the same STROBE to rails in PWR_SEQ0 register, then all rails goes down at the same time.

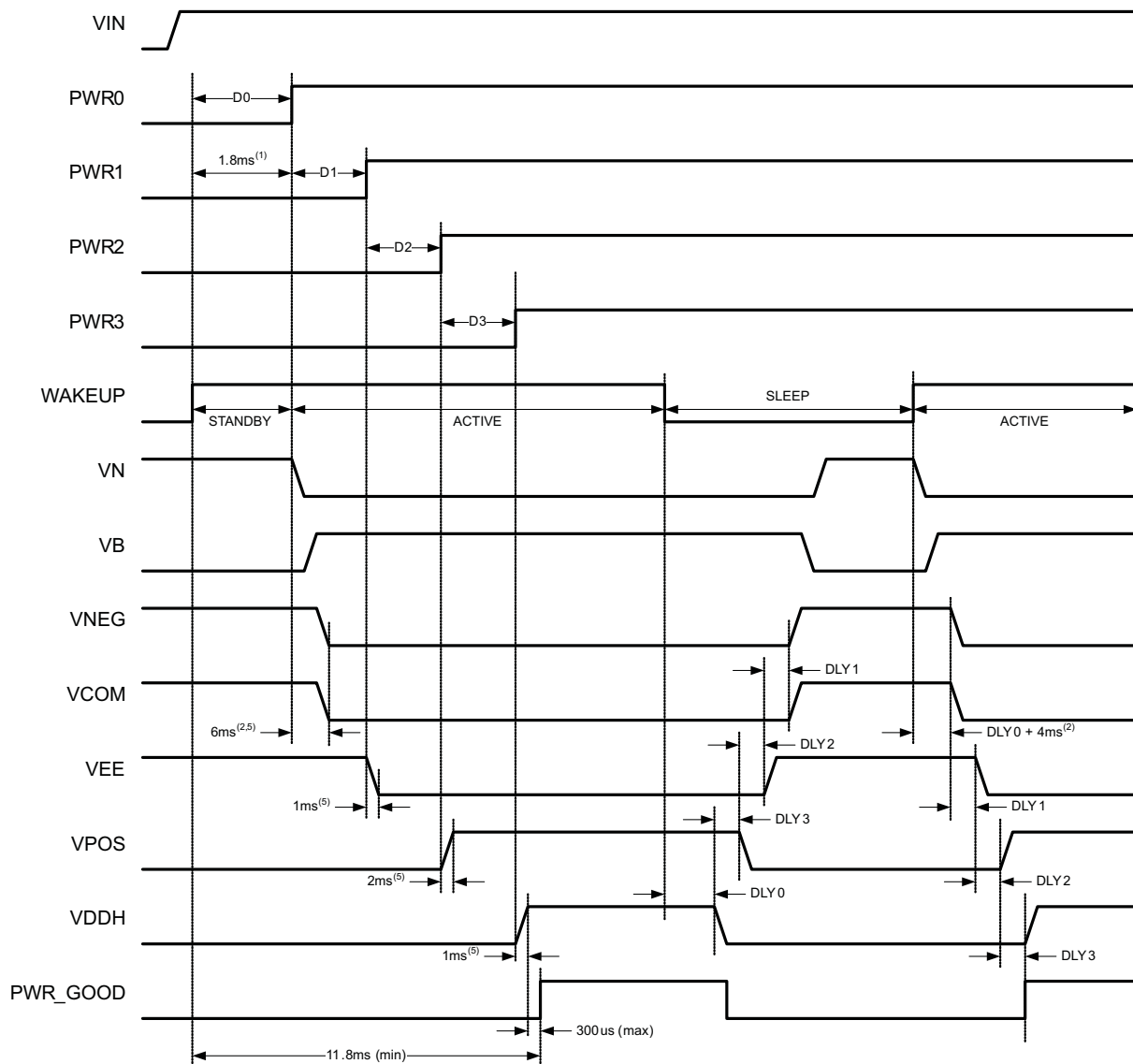
Application Information (continued)

- (1) Minimum delay time between WAKEUP rising edge and IC ready to accept I²C transaction.
 (2) It takes 2ms minimum for each internal boost regulator to start up before VNEG can be enabled.
 (5) It takes up to 2ms for LDOs (VPOS, VNEG) and 1ms for charge pumps (VDDH, VEE), to reach their steady state after being enabled.
 DLY0-DLY3 are power up/down delays defined in register PWR_SEQ1 and PWR_SEQ2.

In this example the first power-up sequence is determined by GPIO control (WAKEUP is pulled high while PWRx pins are low). Power-down and 2nd power-up sequence is controlled by register settings (WAKEUP pin is toggled with at least one PWR pin held high).

Figure 5. Power-Up and Power-Down Timing Diagram

10.1.2 Soft-Start

Soft-start for DCDC1, DCDC2, LDO1, and LDO2 is accomplished by lowering the current limits during start-up. If DCDC1 or DCDC2 are unable to reach power-good status within 10 ms, the corresponding UV flag is set in the interrupt registers, the interrupt pin is pulled low, and the device enters STANDBY mode. LDO1, LDO2, positive and negative charge pumps have a 5-ms power-good timeout limit. If either rail is unable to power up within 5 ms after it has been enabled, the corresponding UV flag is set and the interrupt pin is pulled low. However, the device remains in ACTIVE mode in this case.

Application Information (continued)

10.1.3 VCOM Adjustment

Through the I²C interface the user can select between two methods of VCOM voltage adjustment:

- Using the internal 8-bit DAC and register control.
- Using an external voltage source (resistor divider) connected to the VCOM_XADJ pin.

10.1.4 VCOM Adjustment Through Register Control

By default the TPS65180x is setup for internal VCOM control through the I²C interface. The default setting for the 8-bit DAC is 0x74h which results in 1.25 V \pm 0.8% for VCOM. VCOM can be adjusted up or down in steps of 11 mV (typical) by writing to the VCOM_ADJUST register. The output range for VCOM is limited to –0.3 V to –2.5 V.

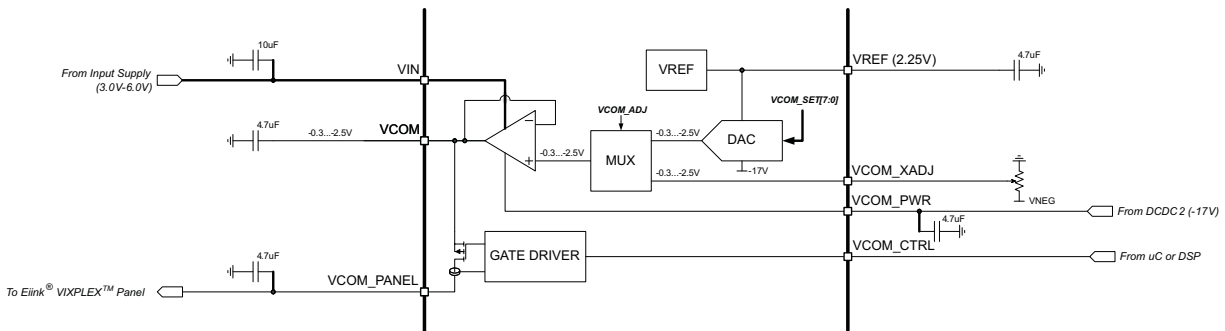

Figure 6. Block Diagram of VCOM Circuit

10.1.5 VCOM Adjustment Through External Potentiometer

VCOM can be adjusted by an external potentiometer by setting the VCOM_ADJ bit of the VN_ADJUST register to 0 and connecting a potentiometer to the VCOM_XADJ pin. The potentiometer must be connected between ground and a negative supply as shown in Figure 6. The gain from VCOM_XADJ to VCOM is 1 and therefore the voltage applied to VCOM_XADJ pin must range from –0.3 V to –2.5 V.

10.1.6 VPOS and VNEG Supply Tracking

LDO1 (VPOS) and LDO2 (VNEG) track each other in a way that they are of opposite sign but same magnitude. The sum of VLDO1 and VLDO2 is guaranteed to be < 50 mV. To ensure proper tracking of the supplies the VPOS_SET[2:0] bits of the VP_ADJUST register must remain at the default setting of 010b. To adjust the VPOS and VNEG output voltage, write to the VN_ADJUST register only and keep the VPOS_SET[2:0] bits of the VP_ADJUST register unchanged.

10.1.7 Fault Handling and Recovery

The TPS6518x and TPS65181xB monitor input and output voltages and die temperature and takes action if operating conditions are outside normal limits. Whenever the TPS6518x and TPS65181xB encounter:

- Thermal shutdown (TSD)
- Positive boost undervoltage (VB_UV)
- Inverting buck-boost undervoltage (VN_UV)
- Input undervoltage lockout (UVLO)

it shuts down all power rails and enter STANDBY mode. Shutdown follows the reverse power-up sequence defined by the PWR_SEQx registers. When a fault is detected, the PWR_GOOD and nINT pin are pulled low and the corresponding interrupt bit is set in the interrupt register.

Whenever the TPS6518x and TPS65181xB encounter undervoltage on VNEG (VNEG_UV), VPOS (VPOS_UV), VEE (VEE_UV) or VDDH (VDDH_UV) it shuts down the corresponding rail (plus any dependent rail) only and remain in ACTIVE mode, allowing the DCDC converters to remain up. Again, the PWR_GOOD and nINT pins is pulled low and the corresponding interrupt bit is set.

Application Information (continued)

10.1.8 TPS65180 and TPS65180B Fault Handling

When a fault is detected, the TPS65180 and TPS65180B set the appropriate interrupt flags in the INT_STATUS1 and INT_STATUS2 registers and pull the INT pin low to signal an interrupt to the host processor. None of the power rails can be re-enabled before the host has read the INT_STATUSx bits and the fault has been removed. As the PWRx inputs are edge-sensitive, the host must also toggle the PWRx pins to re-enable the rails through GPIO control, that is, it must bring the PWRx pins low before asserting them again.

10.1.9 TPS65181 and TPS65181B Fault Handling

The TPS65181 and TPS65181B do not require the host processor to access the INT_STATUS registers before re-enabling the output rails. Rails can be re-enabled as soon as the fault condition has been removed. Again, as the PWRx inputs are edge-sensitive, the host must also toggle the PWRx pins to re-enable the rails through GPIO control, that is, it must bring the PWRx pins low before asserting them again.

10.1.10 Power-Good Pin

The power-good pin (PWR_GOOD) is an open-drain output that is pulled high when all four power rails (CP1, CP2, LDO1, LDO2) are in regulation and is pulled low if any of the rails encounters a fault. PWR_GOOD remains low if one of the rails is not enabled by the host and only after all rails are in regulation PWR_GOOD is released to Hi-Z state (pulled up by external resistor).

10.1.11 Interrupt Pin

The interrupt pin (nINT) is an open-drain output that is pulled low whenever one or more of the INT_STATUS1 or INT_STATUS2 bits are set. The nINT pin is released (returns to Hi-Z state) and fault bits are cleared when the register with the set bit has been read by the host. If the fault persists, the INT_pin is pulled low again after a maximum of 32 μ s.

Interrupt events can be masked by re-setting the corresponding enable bit in the INT_ENABLE1 and INT_ENABLE2 register, that is, the user can determine which events cause the nINT pin to be pulled low. The status of the enable bits affects the nINT pin only and has no effect on any of the protection and monitoring circuits or the INT_STATUSx bits themselves.

Note that persisting fault conditions such as thermal shutdown can cause the nINT pin to be pulled low for an extended period of time which can keep the host in a loop trying to resolve the interrupt. If this behavior is not desired, set the corresponding mask bit after receiving the interrupt and keep polling the INT_STATUSx register to see when the fault condition has disappeared. After the fault is resolved, unmask the interrupt bit again.

10.1.12 Panel Temperature Monitoring

The TPS6518x and TPS65181xB provide circuitry to bias and measure an external negative temperature coefficient resistor (NTC) to monitor device temperature in a range from -10°C to 85°C with an accuracy of $\pm 1^{\circ}\text{C}$ from 0°C to 50°C . The TPS65180 and TPS65180B require the host to trigger the temperature acquisition through an I²C command whereas the TPS65181 and TPS65181B trigger the temperature acquisition automatically once every 60 s.

10.1.13 NTC Bias Circuit

[Figure 7](#) below shows the block diagram of the NTC bias and measurement circuit. The NTC is biased from an internally generated 2.25-V reference voltage through an integrated 7.307-k Ω bias resistor. A 43-k Ω resistor is connected parallel to the NTC to linearize the temperature response curve. The circuit is designed to work with a nominal 10-k Ω NTC and achieves accuracy of $\pm 1^{\circ}\text{C}$ from 0°C to 50°C . The voltage drop across the NTC is digitized by a 10-bit SAR ADC and translated into an 8-bit two's complement by digital per [Table 2](#).

Application Information (continued)

Table 2. ADC Output Value vs Temperature

TEMPERATURE	TMST_VALUE[7:0]
< -10°C	1111 0110
-10°C	1111 0110
-9°C	1111 0111
...	...
-2°C	1111 1110
-1°C	1111 1111
0°C	0000 0000
1°C	0000 0001
2°C	0000 0010
...	...
25°C	0001 1001
...	...
85°C	0101 0101
> 85°C	0101 0101

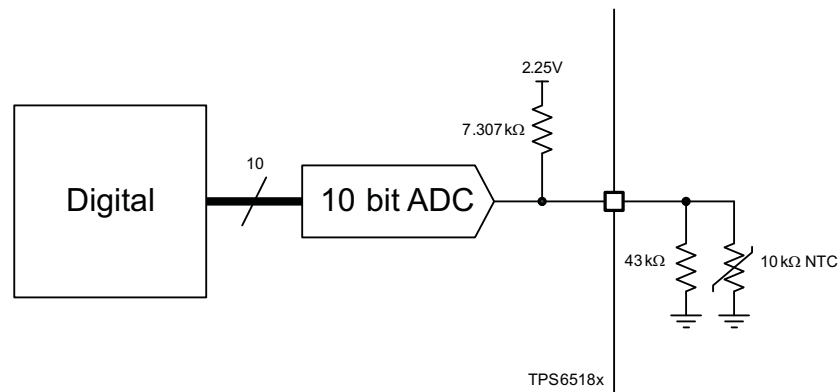

Figure 7. NTC Bias and Measurement Circuit

10.1.14 TPS65180 and TPS65180B Temperature Acquisition

The TPS65180 and TPS65180B require the host to trigger the temperature acquisition before reading the temperature value from register TMST_VALUE. A standard temperature measurement involves the following steps:

1. The host sets the READ_THERM bit of the TMST_CONFIG register to 1. This enabled the NTC bias circuit and internal ADC.
2. The analog to digital conversion is automatically started after a fixed 250-μs delay. While the conversion is in progress the CONV_END bit of the TMST_CONFIG register is held low and returns to 1 after the conversion result is available.
3. After the conversion is complete the READ_THERM bit is automatically reset, the EOC bit of the INT_STATUS2 register is set, and the interrupt pin (nINT) is pulled low.
4. The host services the interrupt by reading the INT_STATUS2 register. This clears the interrupt pin (nINT pin returns high). The host sees the EOC bit set and knows that the temperature data is available in the TMST_VALUE register.
5. The host reads the temperature data from the TMST_VALUE register.

10.1.15 TPS65181 and TPS65181B Temperature Acquisition

The TPS65181 and TPS65181B trigger temperature acquisition once every 60s to reduce the number of required I²C writes. The host or display timing controller can read the temperature at any time by accessing the TMST_VALUE register without having to set the READ_THERM bit first. However, the host can always trigger an additional temperature reading the same way as for the TPS65180 and TPS65180B.

NOTE

At the end of each temperature acquisition, the EOC interrupt is set and an interrupt is issued. Although the interrupt is automatically cleared, the nINT pin is pulled low for a short amount of time (6 μ s). To avoid seeing the EOS interrupt every 60s, TI recommends to mask the EOC interrupt by setting the EOC_EN bit of the INT_ENABLE2 register to 0.

10.1.16 Overtemperature Reporting

The user has the option of setting HOT and COOL (not HOT) temperature thresholds as well as controlling interrupt behavior as the NTC exceeds HOT and cools down below COOL (not-HOT) threshold.

By default, TPS6518x and TPS65181xB compare the temperature conversion result to the HOT threshold after each conversion. If the NTC temperature is above the HOT threshold, the TMST_HOT bit in the INT_STATUS1 register is set to 1 and the interrupt pin (nINT) is pulled low. HOT temperature threshold is set by the host by writing to the TMST_OS register and the HOT interrupt can be disabled by setting the HOT_EN bit of the INT_ENABLE1 register to 0.

When the device has detected that the NTC is above the HOT threshold it compares subsequent temperature acquisitions against the COOL threshold and pull the interrupt pin low when the NTC temperature drops below the COOL threshold. However, the interrupt is issued only if the host has unmasked the COOL interrupt by setting TMST_COOL_EN bit of INT_ENABLE1 register to 1. The COOL threshold is set by the host by writing to the TMST_HYST register.

To use the full functionality of the HOT/COOL interrupts the following actions are required:

1. The host sets the HOT and COOL (not HOT) thresholds by writing the TMST_OS and TMST_HYST registers.
2. (2) For TPS65180 and TPS65180B only: The host sets the READ_THERM bit of the TMST_CONFIG register to 1. This initiates the temperature acquisition.
3. TPS6518x and TPS65181xB compare the result against the TMST_OS threshold and pulls the nINT pin low if the NTC temperature exceeds the HOT threshold.
4. If the TPS6518x and TPS65181xB report a HOT condition, the host un masks the TMST_COOL_EN bit by setting it to 1 (INT_ENABLE1 register).
5. The host initiates a new temperature conversion by setting the READ_THERM bit of the TMST_CONFIG register to 1. If the new temperature is still above the HOT threshold, a new HOT interrupt is issued. If the temperature is below HOT but above COOL threshold, no interrupt is issued (except for EOC which is issued at the end of each conversion). If the temperature is below COOL threshold, a COOL interrupt is issued.
6. After the temperature drops below the COOL threshold the host must set the TMST_COOL_EN bit in the INT_ENABLE1 register to 0 to mask additional COOL interrupts after subsequent temperature acquisitions.

10.1.17 Overtemperature Fault Queuing

The user can specify the number of consecutive HOT temperature reads required to issue a HOT interrupt. The user can set the FAULT_QUE[1:0] bits of the TMST_CONFIG register to specify 1, 2, 4, or 6 consecutive reads that all must be above the HOT threshold before a HOT interrupt is issued. The fault queue is reset each time the acquired temperature drops below the HOT threshold and can also be reset by the host by setting the FAULT_QUE_CLR bit 1. Only if the specified number of readings have been detected which all need to be above the HOT threshold, a HOT interrupt is issued. This function is useful to reduce noise in the temperature measurements.

10.1.18 TPS65181 and TPS65181B Temperature Sensor

The TPS65181 and TPS65181B automates the temperature monitoring process and is specifically designed to operate in multi-host systems where one of the I²C hosts, for example, the display controller, has limited I²C capability. Standard I²C protocol requires the following steps to read data from a register:

1. Send device and register address, R/nW bit set low (write command).
2. Send device address, R/nW set high (read command).
3. The slave responds with data from the specified register address.

Some display controllers support I²C read commands only and need to access the temperature data from the TPS65181 and TPS65181B TMST_VALUE register. To support these systems the TPS65181 and TPS65181B automatically trigger temperature acquisition every 60s (for other acquisition intervals contact the factory) and stores the result in TMST_VALUE register. With the FIX_RD_PTR bit in the FIX_RD_POINTER register set to 1 the device responds to any I²C read command with data from the TMST_VALUE register. No write command with the register address is required and address auto increment feature is disabled in this mode. Therefore reading the temperature data is reduced to two steps:

1. Send device address, R/nW set high (read command).
2. Read the data from the slave. The slave responds with data from TMST_VALUE register address.

Write functionality is not affected by the FIX_RD_PTR bit and the main controller in the system maintains full control of the PMIC. Interrupts and error flags are issued and need to be handled the same way as for the TPS65180 and TPS65180B with two exceptions:

1. The FIX_RD_PTR bit in the FIX_RD_POINTER register needs to be set to 0 before the main controller can read any register different from the TMST_VALUE register.
2. Thermal shutdown (TSD), positive boost undervoltage (VB_UV), inverting buck-boost undervoltage (VN_UV), and input undervoltage lockout (UVLO) interrupt bits do not have to be cleared before output rails can be re-enabled.

At system power-up the main processor sets up the PMIC by accessing the I²C registers and setting the control parameters as needed. When the system is set up correctly, the main controller sets the FIX_READ_POINTER bit and the display controller can start accessing the temperature information. During normal operation the main controller can write to the PMIC at any time but before it can read access registers the FIX_READ_POINTER bit must be written 0.

The temperature range and representation of the temperature data is the same between the TPS65180 and TPS65180B or the TPS65181 and TPS65181B.

10.1.19 I²C Bus Operation

The TPS6518x and TPS65181xB host a slave I²C interface that supports data rates up to 400 kbps and auto-increment addressing and is compliant to I²C standard 3.0.

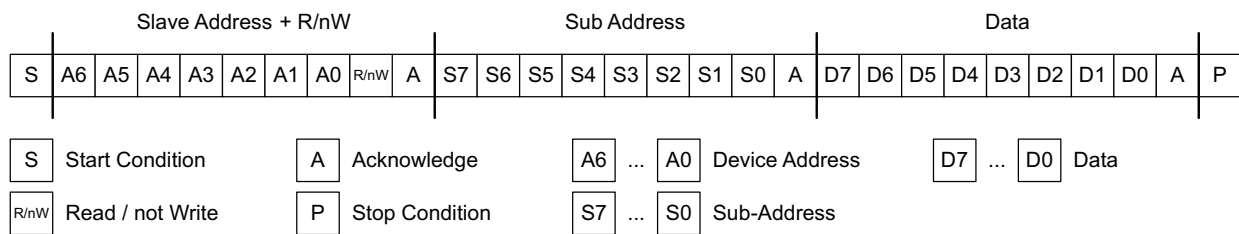

Figure 8. Subaddress in I²C Transmission

Start – Start condition

G(3:0) – Group ID: Address fixed at 1001.

A(2:0) – Device Address: Address fixed at 000.

R/nW – Read / not Write Select Bit

ACK – Acknowledge

S(7:0) – Subaddress: defined per register map.

D(7:0) – Data; Data to be loaded into the device.

Stop – Stop condition

The I²C Bus is a communications link between a controller and a series of slave terminals. The link is established using a two-wired bus consisting of a serial clock signal (SCL) and a serial data signal (SDA). The serial clock is sourced from the controller in all cases where the serial data line is bidirectional for data communication between the controller and the slave terminals. Each device has an open-drain output to transmit data on the serial data line. An external pullup resistor must be placed on the serial data line to pull the drain output high during data transmission.

Data transmission is initiated with a start bit from the controller as shown in Figure 10. The start condition is recognized when the SDA line transitions from high to low during the high portion of the SCL signal. Upon reception of a start bit, the device receives serial data on the SDA input and check for valid address and control information. If the appropriate group and address bits are set for the device, then the device issues an acknowledge pulse and prepare the receive subaddress data. Subaddress data is decoded and responded to as per the Register Maps section of this document. Data transmission is completed by either the reception of a stop condition or the reception of the data word sent to the device. A stop condition is recognized as a low to high transition of the SDA input during the high portion of the SCL signal. All other transitions of the SDA line must occur during the low portion of the SCL signal. An acknowledge is issued after the reception of valid address, sub-address and data words. The I²C interface auto-sequences through register addresses, so that multiple data words can be sent for a given I²C transmission. Reference Figure 10.

NOTE

Auto-increment is not supported when the FIX_RD_PTR bit is set (TPS65181/TPS65181B only).

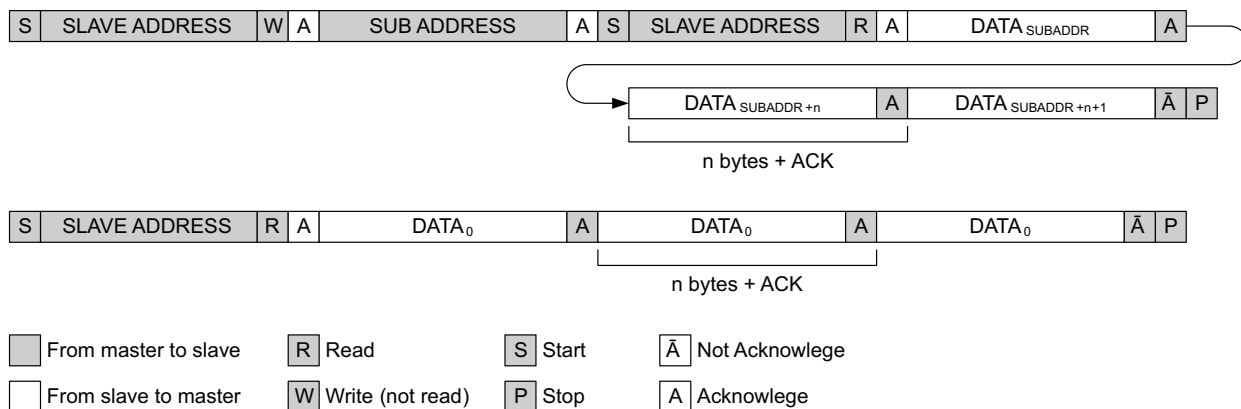

- A. Top: Standard I²C READ data transmission with address auto-increment.
- Bottom: I²C READ data transmission with FIX_RD_PTR bit set for EPSON Broadsheet support.
- Only address 0x00h can be read. FIX_RD_PTR bit has no impact on WRITE transaction.

Figure 9. Standard I²C READ Data Transmission With Address Auto-Increment or With FIX_RD_PTR Bit Set for Epson Broadsheet Support

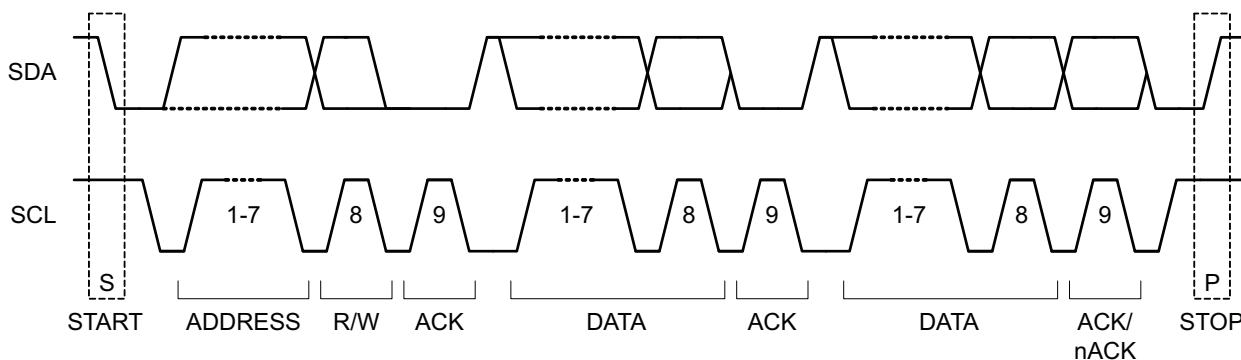

Figure 10. I²C Start, Stop, and Acknowledge Protocol

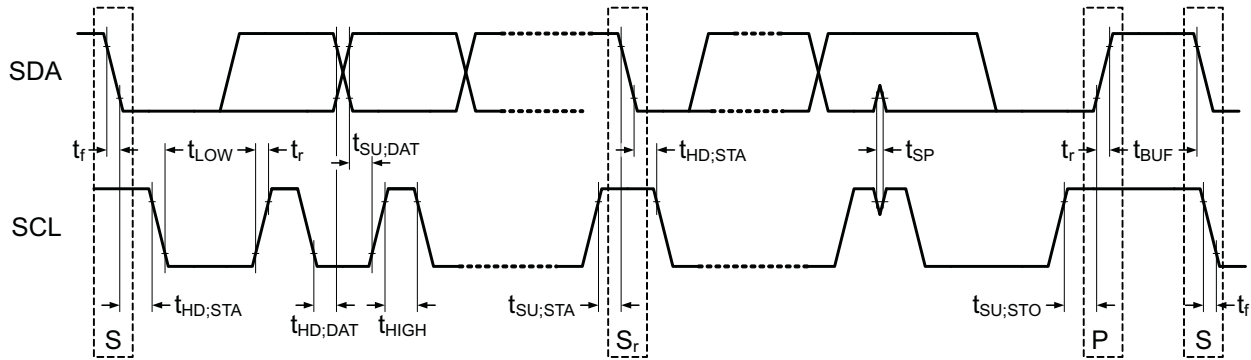

Figure 11. I²C Data Transmission Timing

10.2 Typical Application

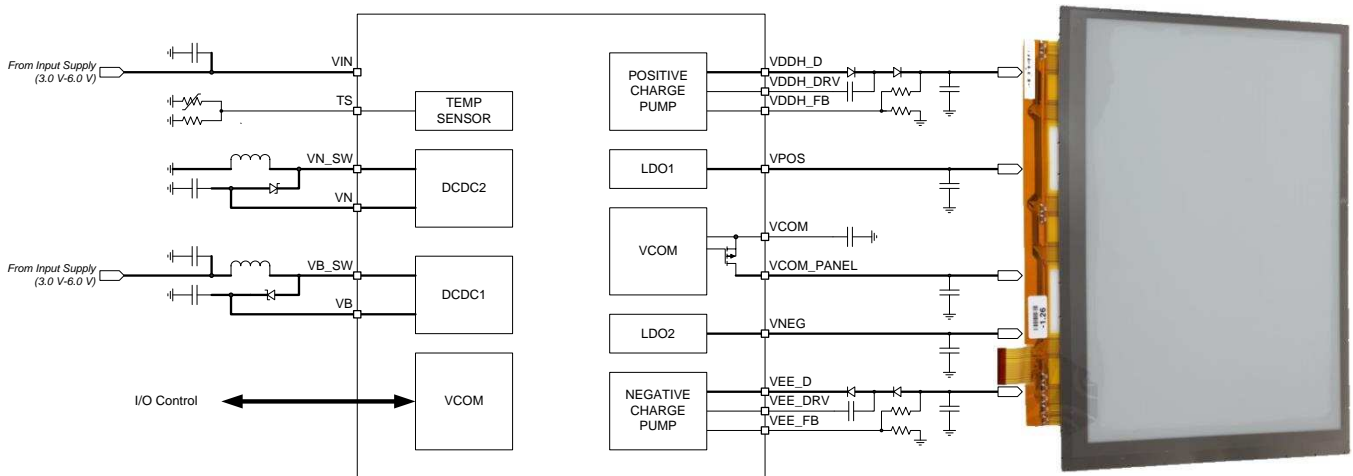

Figure 12. Typical Application

10.2.1 Design Requirements

For this design example, use the parameters listed in [Table 3](#).

Table 3. Design Parameters

	VOLTAGE	SEQUENCE (STROBE)
VNEG (LDO2)	-15 V	1
VEE (Charge pump 2)	-20 V	2
VPOS (LDO1)	15 V	3
VDDH (charge pump 1)	22 V	4

10.2.2 Detailed Design Procedure

For the positive boost regulator (DCDC1) a 10- μ F capacitor can be used as the input capacitor value; two 4.7- μ F capacitor are used as output capacitors to reduce ESR along with a 2.2- μ H inductor. For the inverting buck-boost regulator (DCDC2) an 10- μ F capacitor can be used at the input capacitor value; A 10- μ F and 4.7- μ F capacitor are used as output capacitors to reduce ESR, with a 4.7- μ H inductor. Capacitor ESR for all capacitors should be around 20 m Ω , and ceramic X5R material. These are the typical the values used, additional inductor and capacitor values can be used for improved functionality, but the parts should be rated the same as the recommended external components listed in [Table 4](#).

Table 4. Recommended External Components

PART NUMBER	VALUE	SIZE	MANUFACTURER
INDUCTORS			
LQH44PN4R7MP0	4.7 μ H	4.00 mm x 4.00 mm x 1.65 mm	Murata
VLS252012T-2R2M1R3	2.2 μ H	2.00 mm x 2.50 mm x 1.20 mm	TDK
CAPACITORS			
GRM21BC81E475KA12L	4.7- μ F, 25-V, X6S	805	Murata
GRM32ER71H475KA88L	4.7- μ F, 50-V, X7R	1210	Murata
All other caps	X5R or better		
DIODES			
BAS3010		SOD-323	Infineon
MBR130T1		SOD-123	ON-Semi
THERMISTOR			
NCP18XH103F03RB	10 k Ω	603	Murata

10.2.3 Application Curves

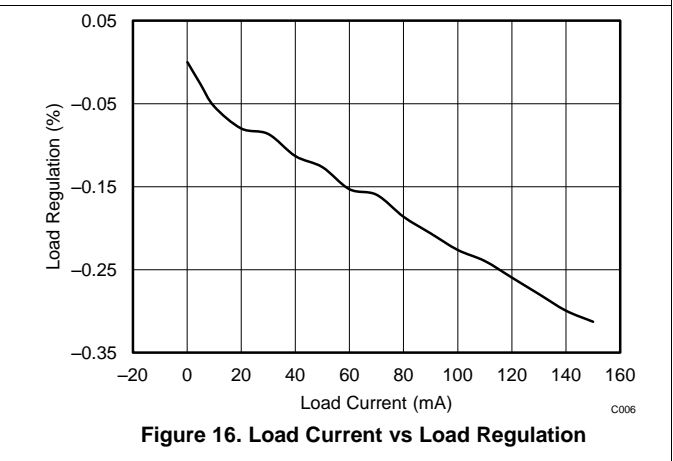
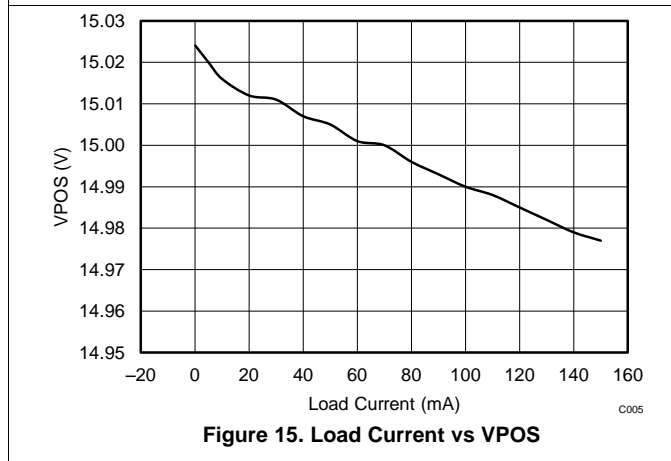
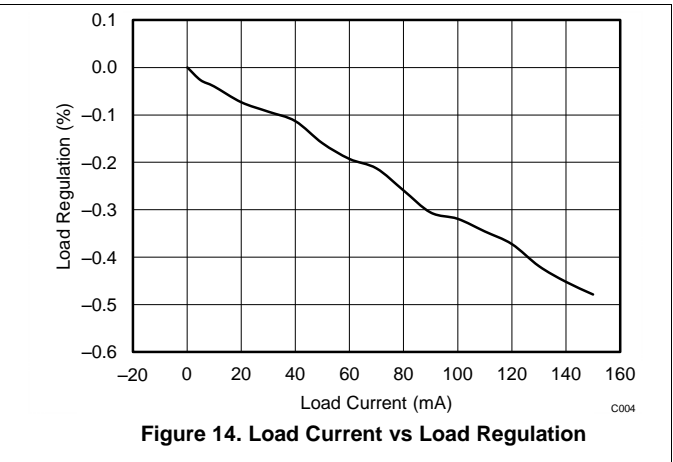
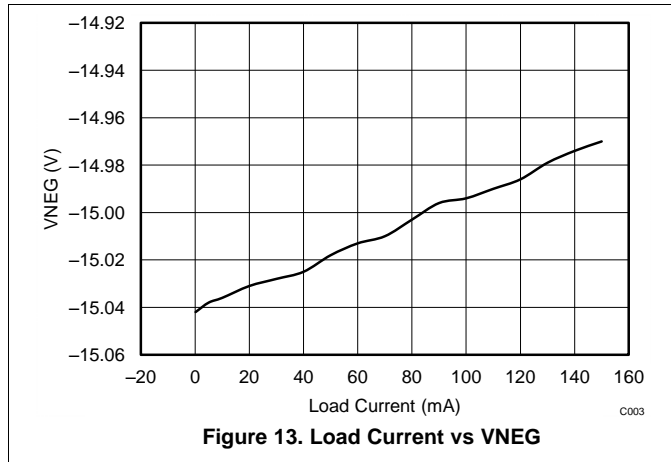

11 Power Supply Recommendations

The device is designed to operate with an input voltage supply range from 3 V to 6 V. This input supply can be from an externally regulated supply. If the input supply is located more than a few inches from the TPS6518x and TPS65181xB, additional bulk capacitance may be required in addition to the ceramic bypass capacitors. An electrolytic capacitor with a value of 10 μ F is a typical choice.

12 Layout

12.1 Layout Guidelines

The layout guidelines are listed as follows.

- PBKG die substrate must connect to VN (–16 V) with short, wide trace. Wide copper trace improves heat dissipation.
- The PowerPAD is internally connected to PBKG and must be connected to ground, but connected to VN with a short, wide copper trace.
- Inductor traces must be kept on the PCB top layer free of any vias.
- Feedback traces must be routed away from any potential noise source to avoid coupling.
- Output caps must be placed immediately at output pin.
- VIN pins must be bypassed to ground with low-ESR ceramic bypass capacitors.

12.2 Layout Example

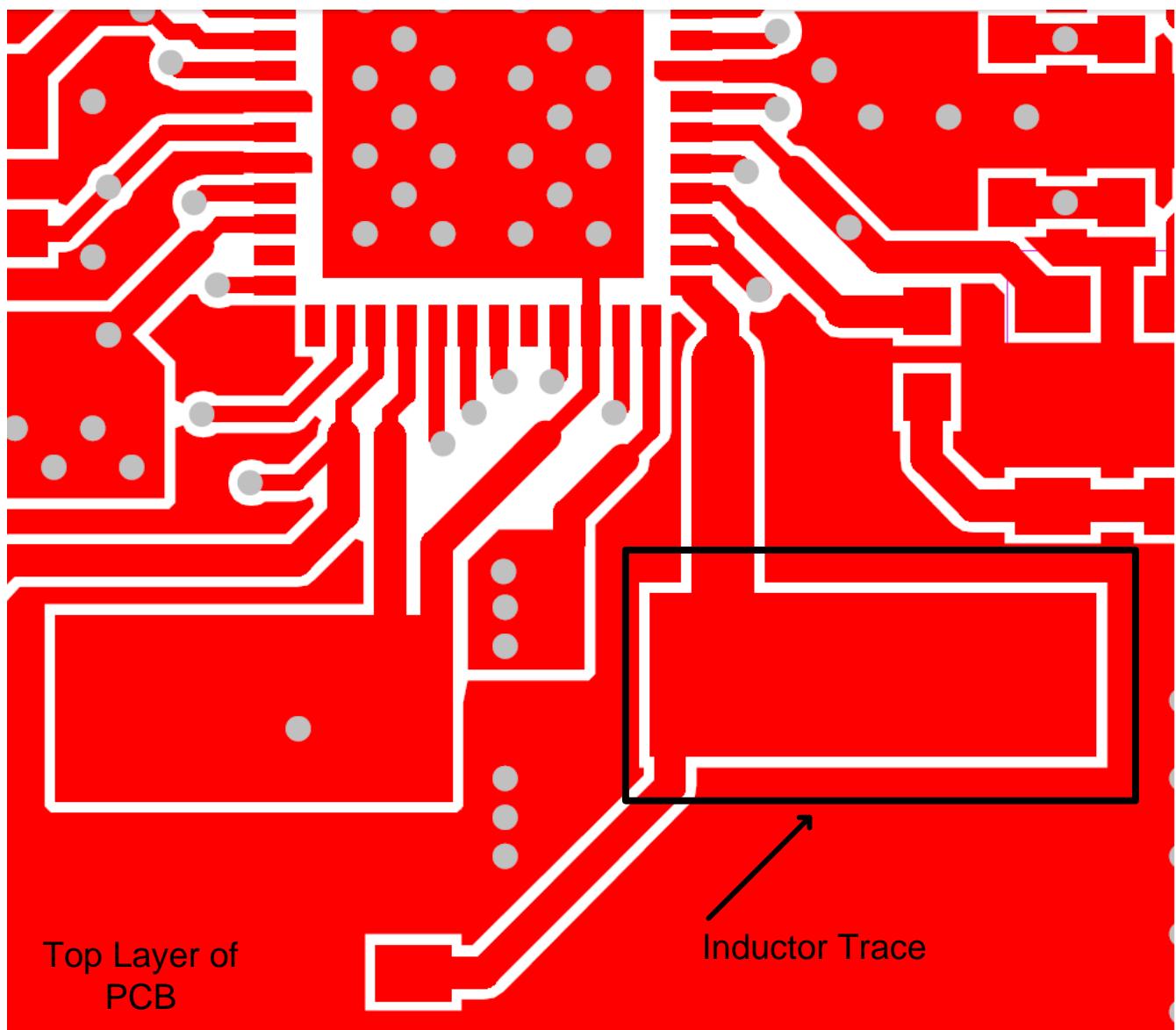

Figure 17. Layout Top Layer

Layout Example (continued)

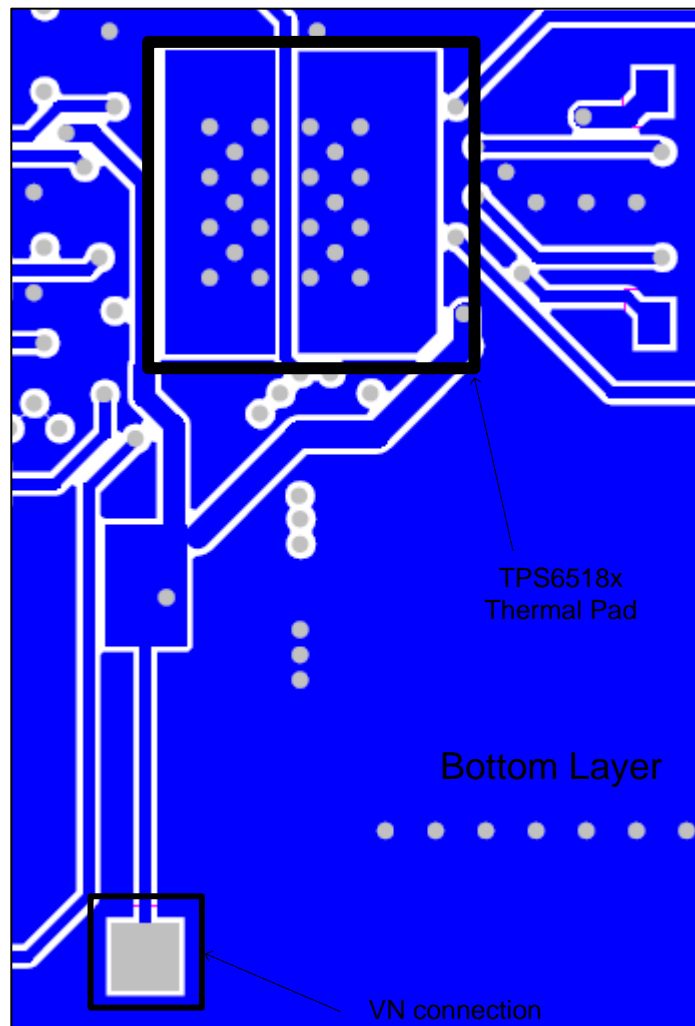

Figure 18. Layout Bottom Layer

13 Device and Documentation Support

13.1 Device Support

13.1.1 Third-Party Products Disclaimer

TI'S PUBLICATION OF INFORMATION REGARDING THIRD-PARTY PRODUCTS OR SERVICES DOES NOT CONSTITUTE AN ENDORSEMENT REGARDING THE SUITABILITY OF SUCH PRODUCTS OR SERVICES OR A WARRANTY, REPRESENTATION OR ENDORSEMENT OF SUCH PRODUCTS OR SERVICES, EITHER ALONE OR IN COMBINATION WITH ANY TI PRODUCT OR SERVICE.

13.2 Documentation Support

13.2.1 Related Documentation

For related documentation, see the following:

- *Basic Calculation of a Boost Converter's Power Stage*, [SLVA372](#)
- *Basic Calculation of a Buck Converter's Power Stage*, [SLVA477](#)

13.3 Related Links

The table below lists quick access links. Categories include technical documents, support and community resources, tools and software, and quick access to sample or buy.

Table 5. Related Links

PARTS	PRODUCT FOLDER	SAMPLE & BUY	TECHNICAL DOCUMENTS	TOOLS & SOFTWARE	SUPPORT & COMMUNITY
TPS65180	Click here	Click here	Click here	Click here	Click here
TPS65181	Click here	Click here	Click here	Click here	Click here
TPS65180B	Click here	Click here	Click here	Click here	Click here
TPS65181B	Click here	Click here	Click here	Click here	Click here

13.4 Community Resources

The following links connect to TI community resources. Linked contents are provided "AS IS" by the respective contributors. They do not constitute TI specifications and do not necessarily reflect TI's views; see TI's [Terms of Use](#).

TI E2E™ Online Community *TI's Engineer-to-Engineer (E2E) Community*. Created to foster collaboration among engineers. At e2e.ti.com, you can ask questions, share knowledge, explore ideas and help solve problems with fellow engineers.

Design Support *TI's Design Support* Quickly find helpful E2E forums along with design support tools and contact information for technical support.

13.5 Trademarks

OMAP, E2E are trademarks of Texas Instruments.
 Vizplex is a trademark of E Ink Corporation.
 E Ink is a registered trademark of E Ink Corporation.
 EPSON is a registered trademark of Seiko Epson Corporation.
 All other trademarks are the property of their respective owners.

13.6 Electrostatic Discharge Caution



These devices have limited built-in ESD protection. The leads should be shorted together or the device placed in conductive foam during storage or handling to prevent electrostatic damage to the MOS gates.

13.7 Glossary

[SLYZ022](#) — *TI Glossary*.

This glossary lists and explains terms, acronyms, and definitions.

14 Mechanical, Packaging, and Orderable Information

The following pages include mechanical, packaging, and orderable information. This information is the most current data available for the designated devices. This data is subject to change without notice and revision of this document. For browser-based versions of this data sheet, refer to the left-hand navigation.

PACKAGING INFORMATION

Orderable Device	Status (1)	Package Type	Package Drawing	Pins	Package Qty	Eco Plan (2)	Lead/Ball Finish (6)	MSL Peak Temp (3)	Op Temp (°C)	Device Marking (4/5)	Samples
TPS65180BRGZR	ACTIVE	VQFN	RGZ	48	2500	Green (RoHS & no Sb/Br)	CU NIPDAU	Level-3-260C-168 HR	-10 to 85	E INK TPS65180B	Samples
TPS65180BRGZT	ACTIVE	VQFN	RGZ	48	250	Green (RoHS & no Sb/Br)	CU NIPDAU	Level-3-260C-168 HR	-10 to 85	E INK TPS65180B	Samples
TPS65181BRGZR	ACTIVE	VQFN	RGZ	48	2500	Green (RoHS & no Sb/Br)	CU NIPDAU	Level-3-260C-168 HR	-10 to 85	E INK TPS65181B	Samples
TPS65181BRGZT	ACTIVE	VQFN	RGZ	48	250	Green (RoHS & no Sb/Br)	CU NIPDAU	Level-3-260C-168 HR	-10 to 85	E INK TPS65181B	Samples
TPS65181RGZR	NRND	VQFN	RGZ	48	2500	Green (RoHS & no Sb/Br)	CU NIPDAU	Level-3-260C-168 HR	-10 to 85	E INK TPS65181	
TPS65181RGZT	NRND	VQFN	RGZ	48		Green (RoHS & no Sb/Br)	CU NIPDAU	Level-3-260C-168 HR	-10 to 85	E INK TPS65181	

(1) The marketing status values are defined as follows:

ACTIVE: Product device recommended for new designs.

LIFEBUY: TI has announced that the device will be discontinued, and a lifetime-buy period is in effect.

NRND: Not recommended for new designs. Device is in production to support existing customers, but TI does not recommend using this part in a new design.

PREVIEW: Device has been announced but is not in production. Samples may or may not be available.

OBSELETE: TI has discontinued the production of the device.

(2) Eco Plan - The planned eco-friendly classification: Pb-Free (RoHS), Pb-Free (RoHS Exempt), or Green (RoHS & no Sb/Br) - please check <http://www.ti.com/productcontent> for the latest availability information and additional product content details.

TBD: The Pb-Free/Green conversion plan has not been defined.

Pb-Free (RoHS): TI's terms "Lead-Free" or "Pb-Free" mean semiconductor products that are compatible with the current RoHS requirements for all 6 substances, including the requirement that lead not exceed 0.1% by weight in homogeneous materials. Where designed to be soldered at high temperatures, TI Pb-Free products are suitable for use in specified lead-free processes.

Pb-Free (RoHS Exempt): This component has a RoHS exemption for either 1) lead-based flip-chip solder bumps used between the die and package, or 2) lead-based die adhesive used between the die and leadframe. The component is otherwise considered Pb-Free (RoHS compatible) as defined above.

Green (RoHS & no Sb/Br): TI defines "Green" to mean Pb-Free (RoHS compatible), and free of Bromine (Br) and Antimony (Sb) based flame retardants (Br or Sb do not exceed 0.1% by weight in homogeneous material)

(3) MSL, Peak Temp. - The Moisture Sensitivity Level rating according to the JEDEC industry standard classifications, and peak solder temperature.

(4) There may be additional marking, which relates to the logo, the lot trace code information, or the environmental category on the device.

(5) Multiple Device Markings will be inside parentheses. Only one Device Marking contained in parentheses and separated by a "~" will appear on a device. If a line is indented then it is a continuation of the previous line and the two combined represent the entire Device Marking for that device.

⁽⁶⁾ Lead/Ball Finish - Orderable Devices may have multiple material finish options. Finish options are separated by a vertical ruled line. Lead/Ball Finish values may wrap to two lines if the finish value exceeds the maximum column width.

Important Information and Disclaimer: The information provided on this page represents TI's knowledge and belief as of the date that it is provided. TI bases its knowledge and belief on information provided by third parties, and makes no representation or warranty as to the accuracy of such information. Efforts are underway to better integrate information from third parties. TI has taken and continues to take reasonable steps to provide representative and accurate information but may not have conducted destructive testing or chemical analysis on incoming materials and chemicals. TI and TI suppliers consider certain information to be proprietary, and thus CAS numbers and other limited information may not be available for release.

In no event shall TI's liability arising out of such information exceed the total purchase price of the TI part(s) at issue in this document sold by TI to Customer on an annual basis.

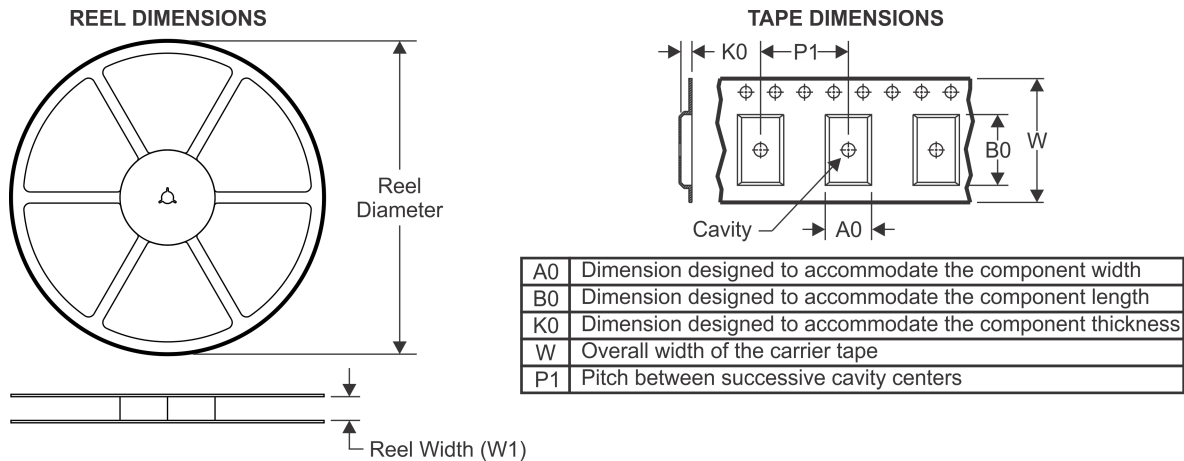
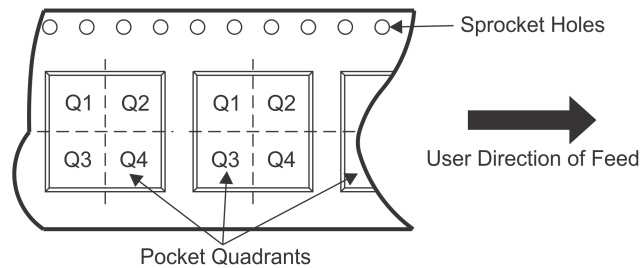
TAPE AND REEL INFORMATION

QUADRANT ASSIGNMENTS FOR PIN 1 ORIENTATION IN TAPE

*All dimensions are nominal

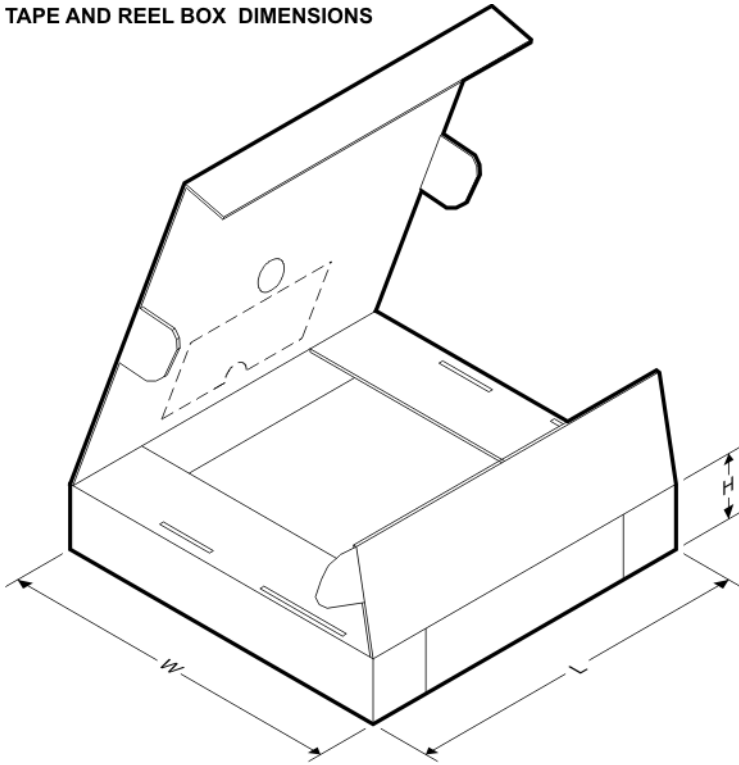
Device	Package Type	Package Drawing	Pins	SPQ	Reel Diameter (mm)	Reel Width W1 (mm)	A0 (mm)	B0 (mm)	K0 (mm)	P1 (mm)	W (mm)	Pin1 Quadrant
TPS65180BRGZR	VQFN	RGZ	48	2500	330.0	16.4	7.3	7.3	1.1	12.0	16.0	Q2
TPS65180BRGZT	VQFN	RGZ	48	250	180.0	16.4	7.3	7.3	1.1	12.0	16.0	Q2
TPS65181BRGZR	VQFN	RGZ	48	2500	330.0	16.4	7.3	7.3	1.1	12.0	16.0	Q2
TPS65181BRGZT	VQFN	RGZ	48	250	180.0	16.4	7.3	7.3	1.1	12.0	16.0	Q2
TPS65181RGZR	VQFN	RGZ	48	2500	330.0	16.4	7.3	7.3	1.1	12.0	16.0	Q2

TAPE AND REEL BOX DIMENSIONS

*All dimensions are nominal

Device	Package Type	Package Drawing	Pins	SPQ	Length (mm)	Width (mm)	Height (mm)
TPS65180BRGZR	VQFN	RGZ	48	2500	367.0	367.0	38.0
TPS65180BRGZT	VQFN	RGZ	48	250	210.0	185.0	35.0
TPS65181BRGZR	VQFN	RGZ	48	2500	367.0	367.0	38.0
TPS65181BRGZT	VQFN	RGZ	48	250	210.0	185.0	35.0
TPS65181RGZR	VQFN	RGZ	48	2500	367.0	367.0	38.0

GENERIC PACKAGE VIEW

RGZ 48

VQFN - 1 mm max height

7 x 7, 0.5 mm pitch

PLASTIC QUADFLAT PACK- NO LEAD

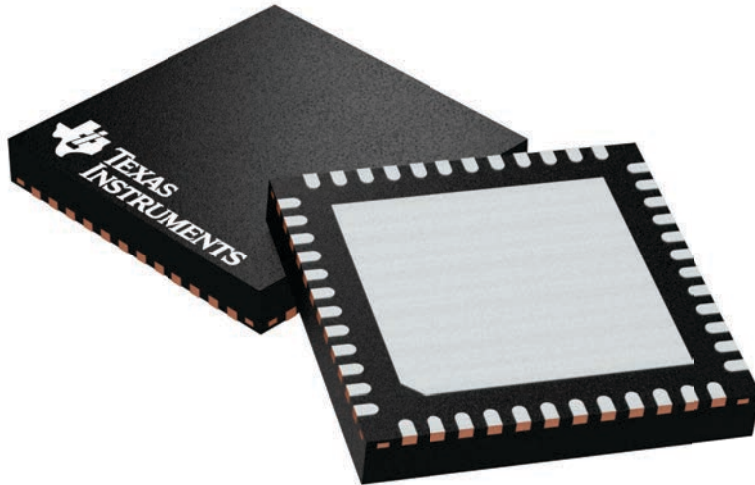

Images above are just a representation of the package family, actual package may vary.
Refer to the product data sheet for package details.

4224671/A

RGZ0048B

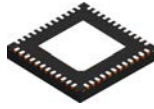

PACKAGE OUTLINE

VQFN - 1 mm max height

PLASTIC QUAD FLATPACK - NO LEAD

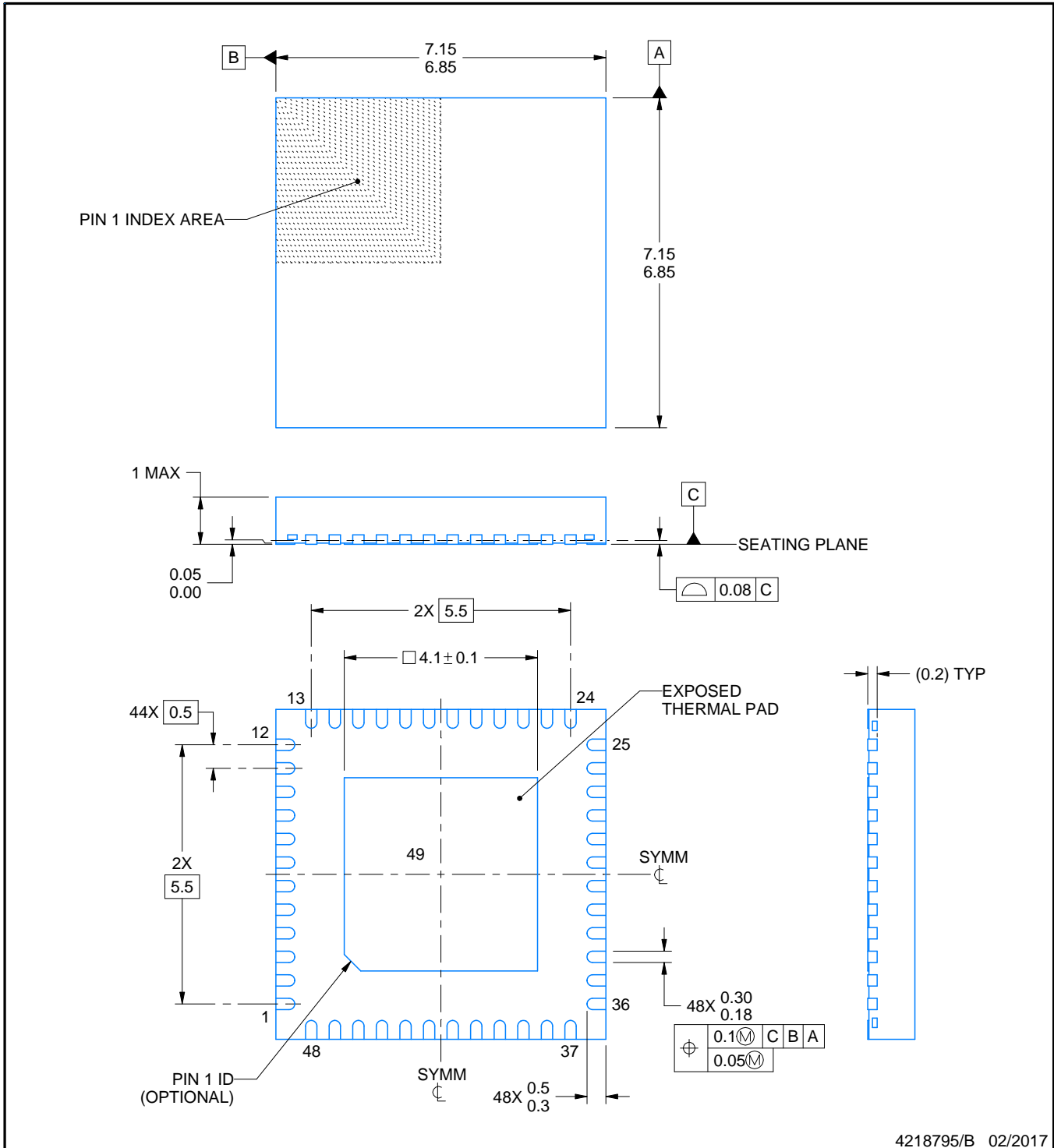

4218795/B 02/2017

NOTES:

1. All linear dimensions are in millimeters. Any dimensions in parenthesis are for reference only. Dimensioning and tolerancing per ASME Y14.5M.
2. This drawing is subject to change without notice.
3. The package thermal pad must be soldered to the printed circuit board for thermal and mechanical performance.

EXAMPLE BOARD LAYOUT

RGZ0048B

VQFN - 1 mm max height

PLASTIC QUAD FLATPACK - NO LEAD

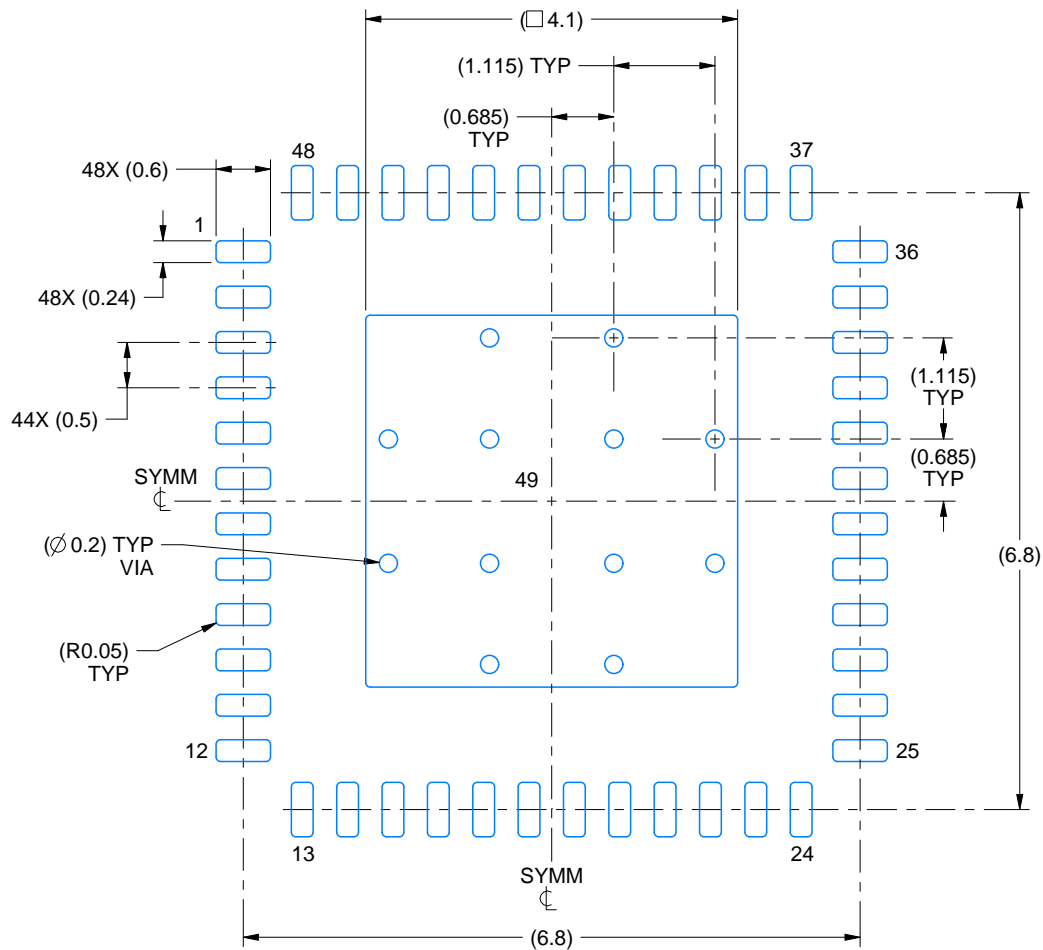

LAND PATTERN EXAMPLE
EXPOSED METAL SHOWN
SCALE:12X

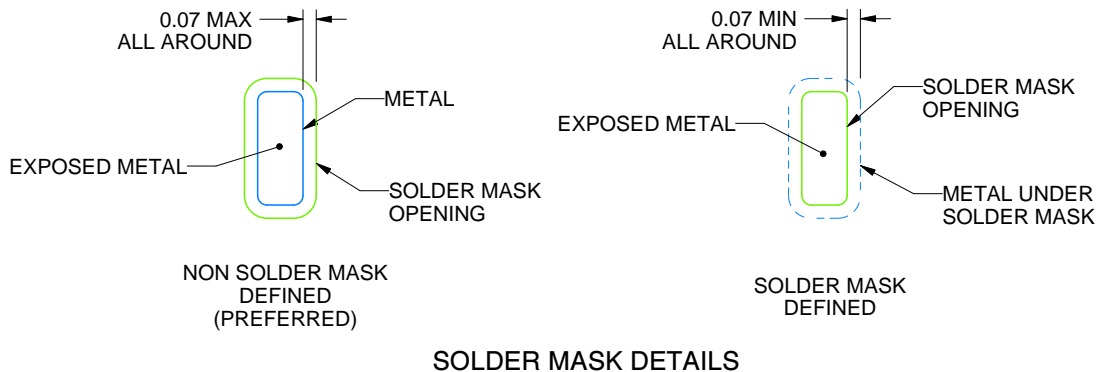

SOLDER MASK DETAILS

4218795/B 02/2017

NOTES: (continued)

4. This package is designed to be soldered to a thermal pad on the board. For more information, see Texas Instruments literature number SLUA271 (www.ti.com/lit/slua271).
5. Vias are optional depending on application, refer to device data sheet. If any vias are implemented, refer to their locations shown on this view. It is recommended that vias under paste be filled, plugged or tented.

EXAMPLE STENCIL DESIGN

RGZ0048B

VQFN - 1 mm max height

PLASTIC QUAD FLATPACK - NO LEAD

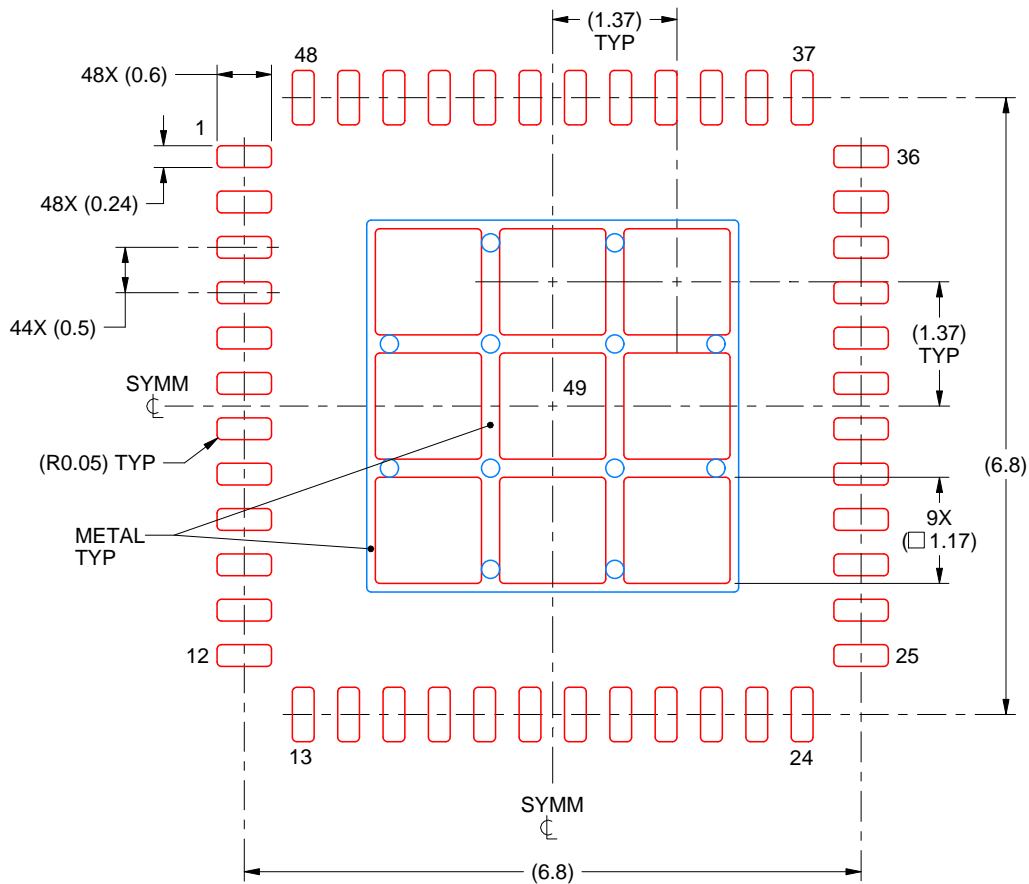

SOLDER PASTE EXAMPLE BASED ON 0.125 mm THICK STENCIL

EXPOSED PAD 49
73% PRINTED SOLDER COVERAGE BY AREA UNDER PACKAGE
SCALE:12X

4218795/B 02/2017

NOTES: (continued)

6. Laser cutting apertures with trapezoidal walls and rounded corners may offer better paste release. IPC-7525 may have alternate design recommendations.

IMPORTANT NOTICE AND DISCLAIMER

TI PROVIDES TECHNICAL AND RELIABILITY DATA (INCLUDING DATASHEETS), DESIGN RESOURCES (INCLUDING REFERENCE DESIGNS), APPLICATION OR OTHER DESIGN ADVICE, WEB TOOLS, SAFETY INFORMATION, AND OTHER RESOURCES "AS IS" AND WITH ALL FAULTS, AND DISCLAIMS ALL WARRANTIES, EXPRESS AND IMPLIED, INCLUDING WITHOUT LIMITATION ANY IMPLIED WARRANTIES OF MERCHANTABILITY, FITNESS FOR A PARTICULAR PURPOSE OR NON-INFRINGEMENT OF THIRD PARTY INTELLECTUAL PROPERTY RIGHTS.

These resources are intended for skilled developers designing with TI products. You are solely responsible for (1) selecting the appropriate TI products for your application, (2) designing, validating and testing your application, and (3) ensuring your application meets applicable standards, and any other safety, security, or other requirements. These resources are subject to change without notice. TI grants you permission to use these resources only for development of an application that uses the TI products described in the resource. Other reproduction and display of these resources is prohibited. No license is granted to any other TI intellectual property right or to any third party intellectual property right. TI disclaims responsibility for, and you will fully indemnify TI and its representatives against, any claims, damages, costs, losses, and liabilities arising out of your use of these resources.

TI's products are provided subject to TI's Terms of Sale (www.ti.com/legal/termsofsale.html) or other applicable terms available either on ti.com or provided in conjunction with such TI products. TI's provision of these resources does not expand or otherwise alter TI's applicable warranties or warranty disclaimers for TI products.

Mailing Address: Texas Instruments, Post Office Box 655303, Dallas, Texas 75265
Copyright © 2019, Texas Instruments Incorporated

Looking for pricing, stock, or lifecycle information?

Click below to explore more details on WIN SOURCE:

 [View TPS65181RGZR on WIN SOURCE](#)

 [Texas Instruments](#) Information

Optimize Your Supply Chain with WIN SOURCE Solutions

-  Global Sourcing Solution
-  Obsolete Management
-  Cost Control Management
-  Shortage Management
-  Alternative Solution
-  Excess Inventory Management