



**THE DATASHEET OF
TPS74301RGWT**





1.5A Ultra-LDO with Programmable Sequencing

 Check for Samples: [TPS743xx](#)

FEATURES

- Track Pin Allows for Flexible Power-Up Sequencing
- 1% Accuracy Over Line, Load, and Temperature
- Supports Input Voltages as Low as 0.9V with External Bias Supply
- Adjustable Output (0.8V to 3.6V)
- Fixed Output (0.9V to 3.6V)
- Ultra-Low Dropout: 55mV at 1.5A (typ)
- Stable with Any or No Output Capacitor
- Excellent Transient Response
- Available in 5mm × 5mm × 1mm QFN and DDPAK-7 Packages
- Open-Drain Power-Good (5 × 5 QFN)
- Active High Enable

APPLICATIONS

- FPGA Applications
- DSP Core and I/O Voltages
- Post-Regulation Applications
- Applications with Special Start-Up Time or Sequencing Requirements

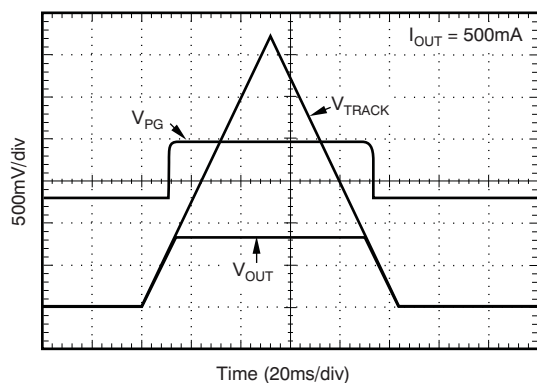
Figure 1. Tracking Response

DESCRIPTION

The TPS743xx low-dropout (LDO) linear regulators provide an easy-to-use robust power management solution for a wide variety of applications. The TRACK pin allows the output to track an external supply. This feature is useful in minimizing the stress on ESD structures that are present between the CORE and I/O power pins of many processors. The enable input and power-good output allow easy sequencing with external regulators. This complete flexibility allows the user to configure a solution that meets the sequencing requirements of FPGAs, DSPs, and other applications with special start-up requirements.

A precision reference and error amplifier deliver 1% accuracy over load, line, temperature, and process. Each LDO is stable with low-cost ceramic output capacitors and the family is fully specified from -40°C to $+125^{\circ}\text{C}$. The TPS743xx is offered in a small (5mm × 5mm) QFN package, yielding a highly compact total solution size. For applications that require additional power dissipation, the DDPAK (KTW) package is also available.

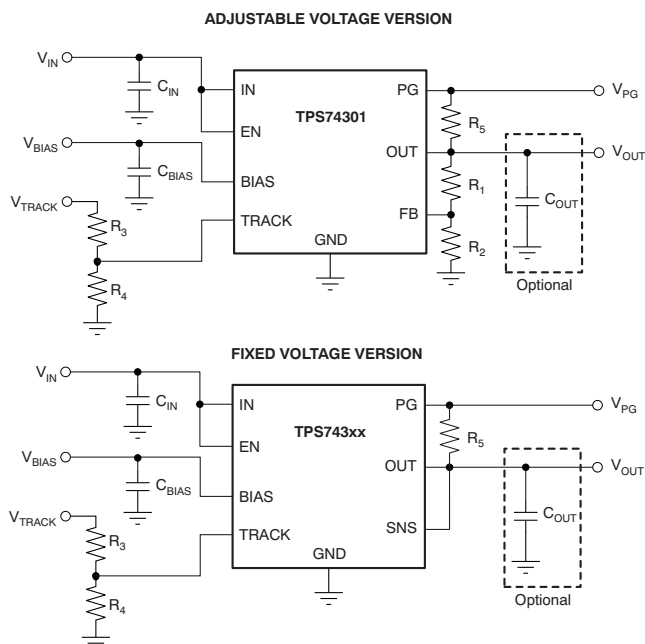
Figure 2. Typical Application Circuit

Please be aware that an important notice concerning availability, standard warranty, and use in critical applications of Texas Instruments semiconductor products and disclaimers thereto appears at the end of this data sheet.

All trademarks are the property of their respective owners.



This integrated circuit can be damaged by ESD. Texas Instruments recommends that all integrated circuits be handled with appropriate precautions. Failure to observe proper handling and installation procedures can cause damage.

ESD damage can range from subtle performance degradation to complete device failure. Precision integrated circuits may be more susceptible to damage because very small parametric changes could cause the device not to meet its published specifications.

ORDERING INFORMATION⁽¹⁾

PRODUCT	V _{OUT} ⁽²⁾
TPS743xx yyy z	XX is nominal output voltage (for example, 12 = 1.2V, 15 = 1.5V, 01 = Adjustable). ⁽³⁾ YYY is package designator. Z is package quantity.

- (1) For the most current package and ordering information see the Package Option Addendum at the end of this document, or see the TI website at www.ti.com.
- (2) Output voltages from 0.9V to 1.5V in 50mV increments and 1.5V to 3.3V in 100mV increments are available through the use of innovative factory EEPROM programming; minimum order quantities may apply. Contact factory for details and availability.
- (3) For fixed 0.8V operation, tie FB to OUT.

ABSOLUTE MAXIMUM RATINGS⁽¹⁾

At T_J = –40°C to +125°C, unless otherwise noted. All voltages are with respect to GND.

	TPS743xx	UNIT
V _{IN} , V _{BIAS} Input voltage range	–0.3 to +6	V
V _{EN} Enable voltage range	–0.3 to +6	V
V _{PG} Power-good voltage range	–0.3 to +6	V
I _{PG} PG sink current	0 to +1.5	mA
V _{TRACK} Track pin voltage range	–0.3 to +6	V
V _{FB} Feedback pin voltage range	–0.3 to +6	V
V _{OUT} Output voltage range	–0.3 to V _{IN} + 0.3	V
I _{OUT} Maximum output current	Internally limited	
Output short circuit duration	Indefinite	
P _{DISS} Continuous total power dissipation	See Thermal Information Table	
T _J Operating junction temperature range	–40 to +125	°C
T _{STG} Storage junction temperature range	–55 to +150	°C

- (1) Stresses beyond those listed under *Absolute Maximum Ratings* may cause permanent damage to the device. These are stress ratings only and functional operation of the device at these conditions is not implied. Exposure to absolute-maximum-rated conditions for extended periods may affect device reliability.

THERMAL INFORMATION

THERMAL METRIC ⁽¹⁾		TPS743xx ⁽²⁾		UNITS
		RGW (20 PINS)	KTW (7 PINS)	
θ_{JA}	Junction-to-ambient thermal resistance ⁽³⁾	30.5	20.1	°C/W
θ_{JcTop}	Junction-to-case (top) thermal resistance ⁽⁴⁾	27.6	2.1	
θ_{JB}	Junction-to-board thermal resistance ⁽⁵⁾	N/A	N/A	
ψ_{JT}	Junction-to-top characterization parameter ⁽⁶⁾	0.37	4.2	
ψ_{JB}	Junction-to-board characterization parameter ⁽⁷⁾	10.6	6.1	
θ_{JcBot}	Junction-to-case (bottom) thermal resistance ⁽⁸⁾	4.1	1.4	

- (1) For more information about traditional and new thermal metrics, see the *IC Package Thermal Metrics* application report, [SPRA953A](#).
- (2) Thermal data for the RGW and KTW packages are derived by thermal simulations based on JEDEC-standard methodology as specified in the JESD51 series. The following assumptions are used in the simulations:
 - (a) i. RGW: The exposed pad is connected to the PCB ground layer through a 4x4 thermal via array.
ii. KTW: The exposed pad is connected to the PCB ground layer through a 6x6 thermal via array.
 - (b) Each of top and bottom copper layers has a dedicated pattern for 20% copper coverage.
 - (c) These data were generated with only a single device at the center of a JEDEC high-K (2s2p) board with 3in x 3in copper area. To understand the effects of the copper area on thermal performance, refer to the [Power Dissipation](#) and [Estimating Junction Temperature](#) sections.
- (3) The junction-to-ambient thermal resistance under natural convection is obtained in a simulation on a JEDEC-standard, high-K board, as specified in JESD51-7, in an environment described in JESD51-2a.
- (4) The junction-to-case (top) thermal resistance is obtained by simulating a cold plate test on the top of the package. No specific JEDEC-standard test exists, but a close description can be found in the ANSI SEMI standard G30-88.
- (5) The junction-to-board thermal resistance is obtained by simulating in an environment with a ring cold plate fixture to control the PCB temperature, as described in JESD51-8.
- (6) The junction-to-top characterization parameter, ψ_{JT} , estimates the junction temperature of a device in a real system and is extracted from the simulation data to obtain θ_{JA} using a procedure described in JESD51-2a (sections 6 and 7).
- (7) The junction-to-board characterization parameter, ψ_{JB} , estimates the junction temperature of a device in a real system and is extracted from the simulation data to obtain θ_{JA} using a procedure described in JESD51-2a (sections 6 and 7).
- (8) The junction-to-case (bottom) thermal resistance is obtained by simulating a cold plate test on the exposed (power) pad. No specific JEDEC standard test exists, but a close description can be found in the ANSI SEMI standard G30-88.

ELECTRICAL CHARACTERISTICS

At $V_{EN} = 1.1V$, $V_{IN} = V_{OUT} + 0.3V$, $C_{IN} = C_{BIAS} = 0.1\mu F$, $C_{OUT} = 10\mu F$, $I_{OUT} = 50mA$, $V_{BIAS} = 5.0V$, and $T_J = -40^\circ C$ to $+125^\circ C$, unless otherwise noted. Typical values are at $T_J = +25^\circ C$.

PARAMETER		TEST CONDITIONS	TPS743xx			UNIT
			MIN	TYP	MAX	
V_{IN}	Input voltage range		$V_{OUT} + V_{DO}$		5.5	V
V_{BIAS}	Bias pin voltage range		2.375		5.25	V
V_{REF}	Internal reference (Adj.)	$T_J = +25^\circ C$	0.796	0.8	0.804	V
V_{OUT}	Output voltage range	$V_{IN} = 5V$, $I_{OUT} = 1.5A$, $V_{BIAS} = 5V$	V_{REF}		3.6	V
	Accuracy ⁽¹⁾	$2.375V \leq V_{BIAS} \leq 5.25V$, $V_{OUT} + 1.62V \leq V_{BIAS}$ $50mA \leq I_{OUT} \leq 1.5A$	-1	± 0.2	1	%
V_{OUT}/V_{IN}	Line regulation	$V_{OUT(NOM)} + 0.3 \leq V_{IN} \leq 5.5V$, QFN		0.0005	0.05	%V
		$V_{OUT(NOM)} + 0.3 \leq V_{IN} \leq 5.5V$, DDPAK		0.0005	0.06	
V_{OUT}/I_{OUT}	Load regulation	$0mA \leq I_{OUT} \leq 50mA$		0.013		%/mA
		$50mA \leq I_{OUT} \leq 1.5A$		0.04		%/A
V_{DO}	V_{IN} dropout voltage ⁽²⁾	$I_{OUT} = 1.5A$, $V_{BIAS} - V_{OUT(NOM)} \geq 1.62V$, QFN		55	100	mV
		$I_{OUT} = 1.5A$, $V_{BIAS} - V_{OUT(NOM)} \geq 1.62V$, DDPAK		60	120	
	V_{BIAS} dropout voltage ⁽²⁾	$I_{OUT} = 1.5A$, $V_{IN} = V_{BIAS}$			1.4	V
I_{CL}	Current limit	$V_{OUT} = 80\% \times V_{OUT(NOM)}$	1.8		4	A
I_{BIAS}	Bias pin current	$I_{OUT} = 0mA$ to $1.5A$		2	4	mA
I_{SHDN}	Shutdown supply current (V_{IN})	$V_{EN} \leq 0.4V$		1	100	μA
I_{FB} , I_{SNS}	Feedback, Sense pin current ⁽³⁾	$I_{OUT} = 50mA$ to $1.5A$	-250	68	250	nA
PSRR	Power-supply rejection (V_{IN} to V_{OUT})	1kHz, $I_{OUT} = 1.5A$, $V_{IN} = 1.8V$, $V_{OUT} = 1.5V$		73		dB
		800kHz, $I_{OUT} = 1.5A$, $V_{IN} = 1.8V$, $V_{OUT} = 1.5V$		42		
	Power-supply rejection (V_{BIAS} to V_{OUT})	1kHz, $I_{OUT} = 1.5A$, $V_{IN} = 1.8V$, $V_{OUT} = 1.5V$		67		dB
		800kHz, $I_{OUT} = 1.5A$, $V_{IN} = 1.8V$, $V_{OUT} = 1.5V$		50		
Noise	Output noise voltage	100Hz to 100kHz, $I_{OUT} = 1.5A$		$25 \times V_{OUT}$		μV_{RMS}
V_{TRAN}	% V_{OUT} droop during load transient	$I_{OUT} = 50mA$ to $1.5A$ at $1A/\mu s$, $C_{OUT} = \text{none}$		3.5		% V_{OUT}
t_{STR}	Minimum startup time	$V_{TRACK} > 0.8V$		40		μs
T_{ACC}	Track pin accuracy	$0.2V \leq V_{TRACK} \leq 0.7V$, $V_{OUT} = 0.8V$	-60		60	mV
I_{TR}	Track pin current	$V_{TRACK} = 0.4V$		0.1	1	μA
$V_{EN, HI}$	Enable input high level		1.1		5.5	V
$V_{EN, LO}$	Enable input low level		0		0.4	V
$V_{EN, HYS}$	Enable pin hysteresis			50		mV
$V_{EN, DG}$	Enable pin deglitch time			20		μs
I_{EN}	Enable pin current	$V_{EN} = 5V$		0.1	1	μA
V_{IT}	PG trip threshold	V_{OUT} decreasing	86.5	90	93.5	% V_{OUT}
V_{HYS}	PG trip hysteresis			3		% V_{OUT}
$V_{PG, LO}$	PG output low voltage	$I_{PG} = 1mA$ (sinking), $V_{OUT} < V_{IT}$			0.3	V
$I_{PG, LKG}$	PG leakage current	$V_{PG} = 5.25V$, $V_{OUT} > V_{IT}$		0.3	1	μA
T_J	Operating junction temperature		-40		+125	$^\circ C$
T_{SD}	Thermal shutdown temperature	Shutdown, temperature increasing		+155		$^\circ C$
		Reset, temperature decreasing		+140		

- (1) Adjustable devices tested at 0.8V; external resistor tolerance is not taken into account.
(2) Dropout is defined as the voltage from the input to V_{OUT} when V_{OUT} is 2% below nominal.
(3) I_{FB} , I_{SNS} current flow is out of the device.

BLOCK DIAGRAMS

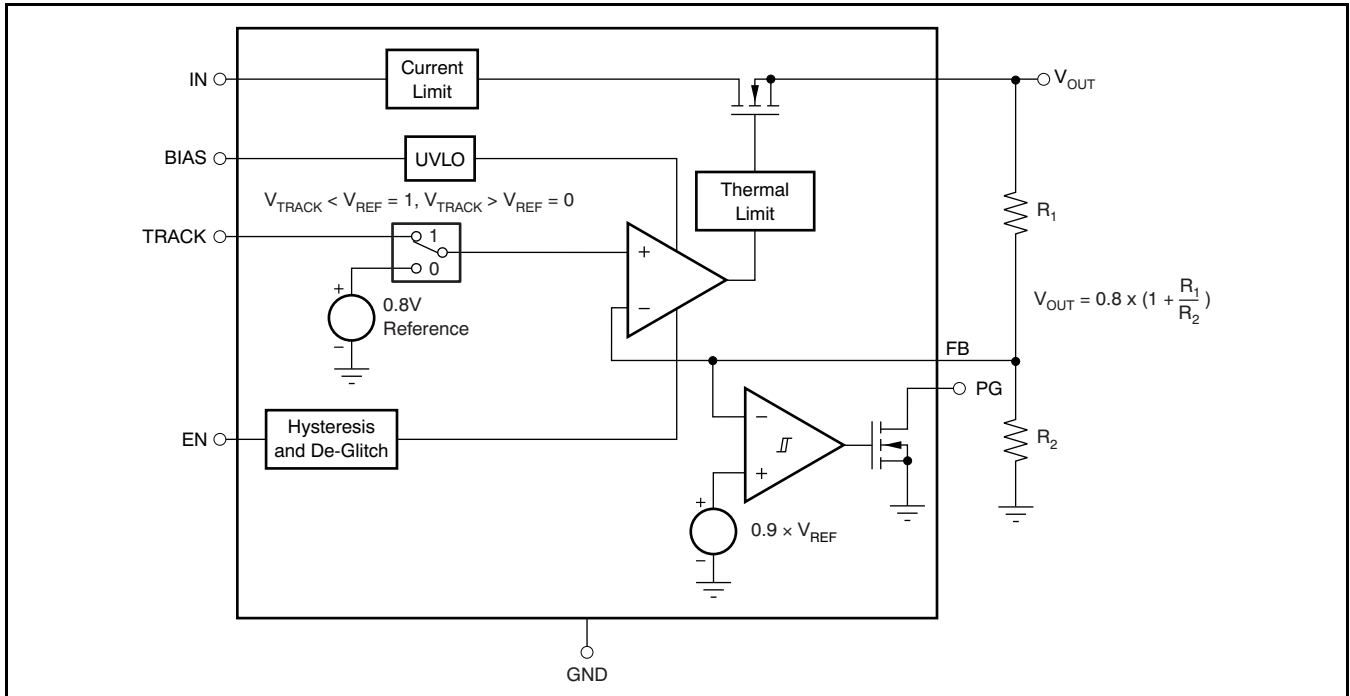

Figure 3. Adjustable Voltage Version

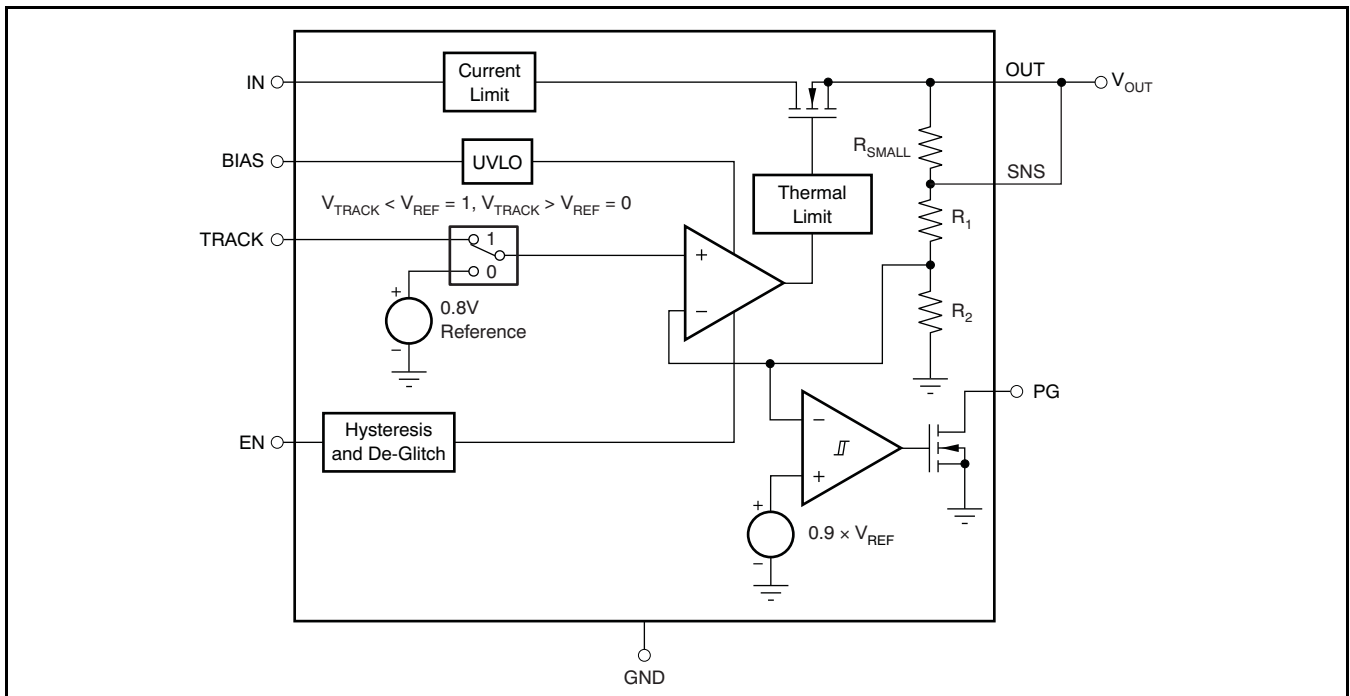

Figure 4. Fixed Voltage Versions

Table 1. Standard 1% Resistor Values for Programming the Output Voltage⁽¹⁾

R ₁ (kΩ)	R ₂ (kΩ)	V _{OUT} (V)
Short	Open	0.8
0.619	4.99	0.9
1.13	4.53	1.0
1.37	4.42	1.05
1.87	4.99	1.1
2.49	4.99	1.2
4.12	4.75	1.5
3.57	2.87	1.8
3.57	1.69	2.5
3.57	1.15	3.3

(1) $V_{OUT} = 0.8 \times (1 + R_1/R_2)$

PIN CONFIGURATIONS

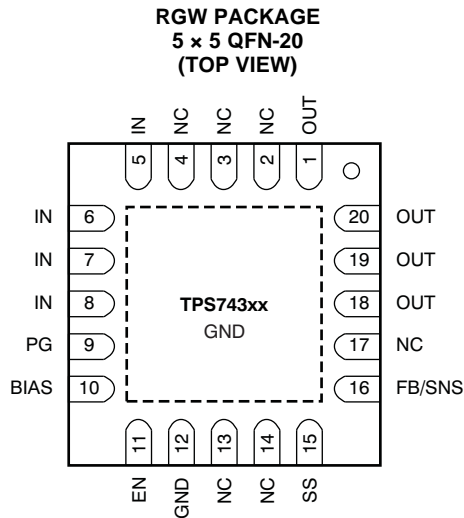

KTW PACKAGE
DDPAK-7
SURFACE-MOUNT

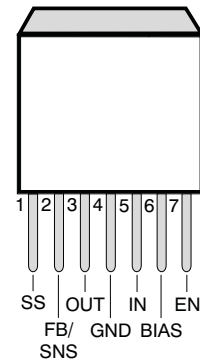

PIN DESCRIPTIONS

NAME	KTW (DDPAK)	RGW (QFN)	DESCRIPTION
IN	5	5–8	Unregulated input to the device.
EN	7	11	Enable pin. Driving this pin high enables the regulator. Driving this pin low puts the regulator into shutdown mode. This pin must not be left floating.
TRACK	1	15	Tracking pin. Connect this pin to the center tap of a resistor divider off of an external supply to program the device to track an external supply.
BIAS	6	10	Bias input voltage for error amplifier, reference, and internal control circuits.
PG	N/A	9	Power-Good (PG) is an open-drain, active-high output that indicates the status of V_{OUT} . When V_{OUT} exceeds the PG trip threshold, the PG pin goes into a high-impedance state. When V_{OUT} is below this threshold the pin is driven to a low-impedance state. A pull-up resistor from 10k Ω to 1M Ω should be connected from this pin to a supply up to 5.5V. The supply can be higher than the input voltage. Alternatively, the PG pin can be left floating if output monitoring is not necessary.
FB	2	16	This pin is the feedback connection to the center tap of an external resistor divider network that sets the output voltage. This pin must not be left floating. (Adjustable version only.)
SNS			This pin is the sense connection to the load device. This pin must be connected to V_{OUT} and must not be left floating. (Fixed versions only.)
OUT	3	1, 18–20	Regulated output voltage. No capacitor is required on this pin for stability.
NC	N/A	2–4, 13, 14, 17	No connection. This pin can be left floating or connected to GND to allow better thermal contact to the top-side plane.
GND	4	12	Ground
PAD/TAB			Should be soldered to the ground plane for increased thermal performance.

TYPICAL CHARACTERISTICS

At $T_J = +25^\circ\text{C}$, $V_{\text{OUT}} = 1.5\text{V}$, $V_{\text{IN}} = V_{\text{OUT(TYP)}} + 0.3\text{V}$, $V_{\text{BIAS}} = 3.3\text{V}$, $I_{\text{OUT}} = 50\text{mA}$, $\text{EN} = V_{\text{IN}}$, $C_{\text{IN}} = 1\mu\text{F}$, $C_{\text{BIAS}} = 4.7\mu\text{F}$, and $C_{\text{OUT}} = 10\mu\text{F}$, unless otherwise noted.

LOAD REGULATION

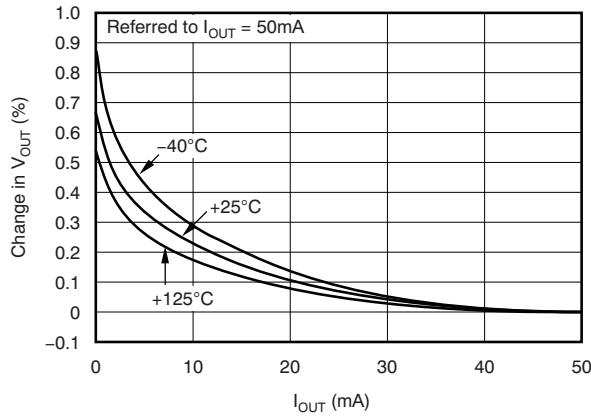

Figure 5.

LOAD REGULATION

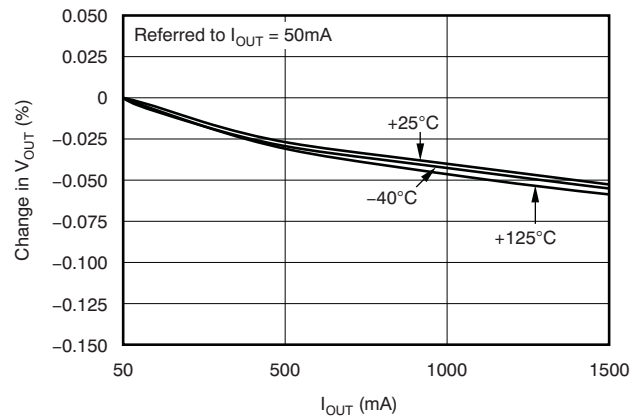

Figure 6.

LINE REGULATION

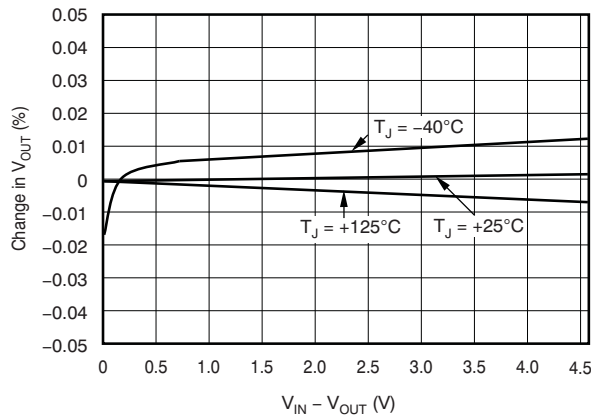

Figure 7.

VIN DROPOUT VOLTAGE vs IOUT AND TEMPERATURE (Tj)

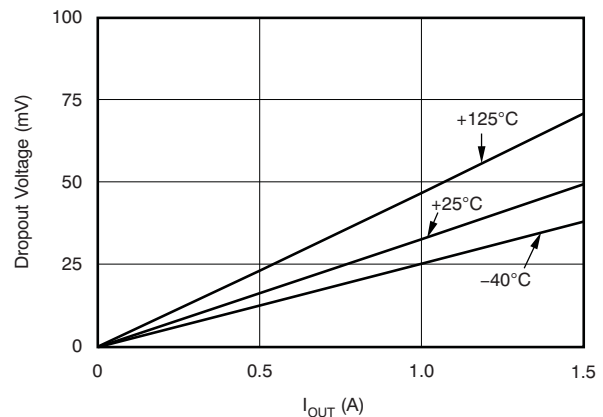

Figure 8.

VIN DROPOUT VOLTAGE vs VBIAS - VOUT AND TEMPERATURE (Tj)

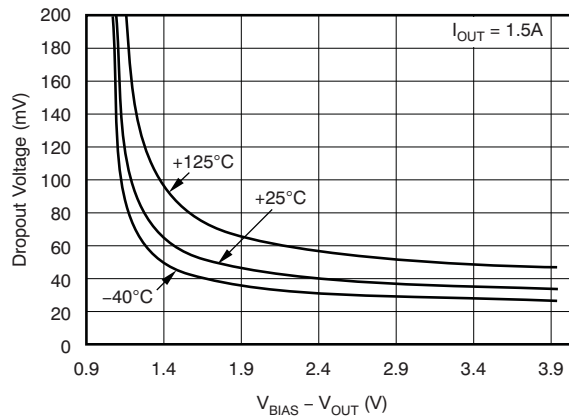

Figure 9.

VIN DROPOUT VOLTAGE vs VBIAS - VOUT AND TEMPERATURE (Tj)

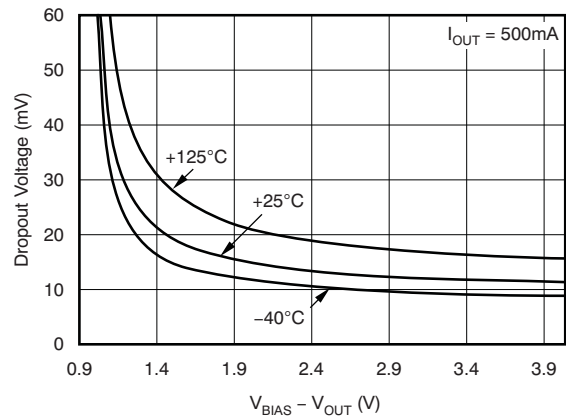

Figure 10.

TYPICAL CHARACTERISTICS (continued)

At $T_J = +25^\circ\text{C}$, $V_{OUT} = 1.5\text{V}$, $V_{IN} = V_{OUT(TYP)} + 0.3\text{V}$, $V_{BIAS} = 3.3\text{V}$, $I_{OUT} = 50\text{mA}$, $EN = V_{IN}$, $C_{IN} = 1\mu\text{F}$, $C_{BIAS} = 4.7\mu\text{F}$, and $C_{OUT} = 10\mu\text{F}$, unless otherwise noted.

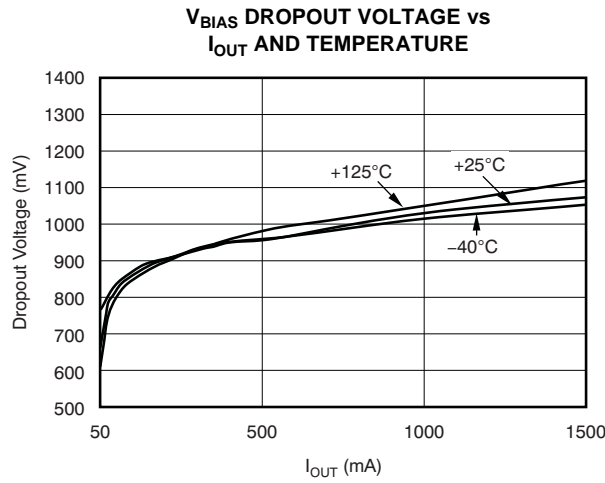

Figure 11.

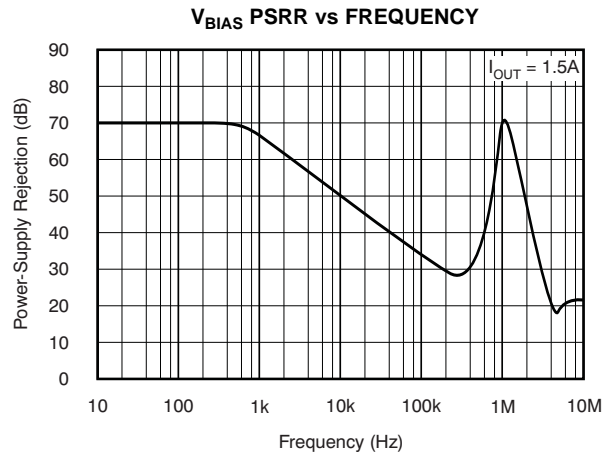

Figure 12.

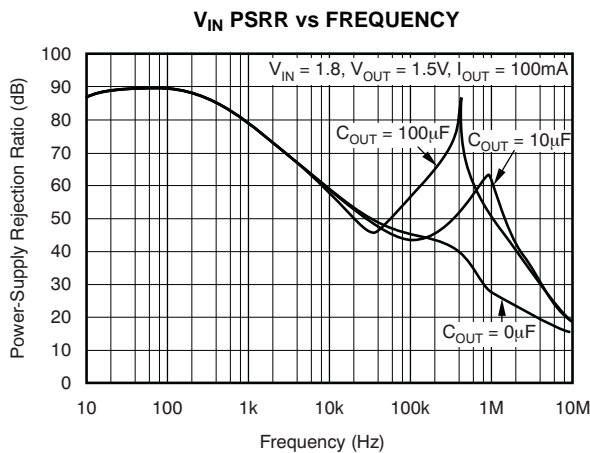

Figure 13.

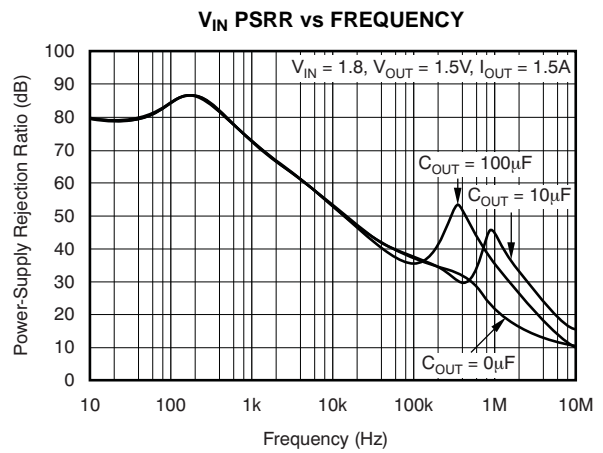

Figure 14.

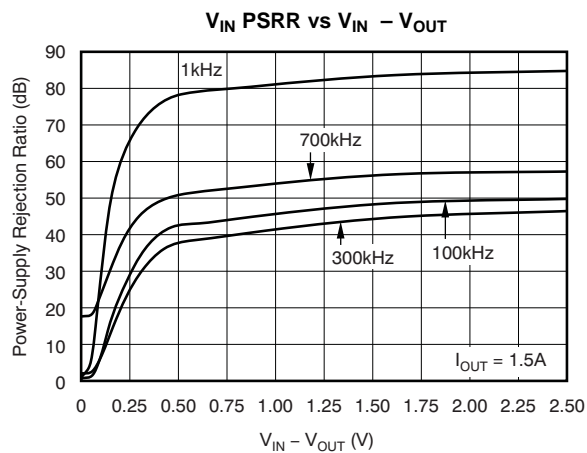

Figure 15.

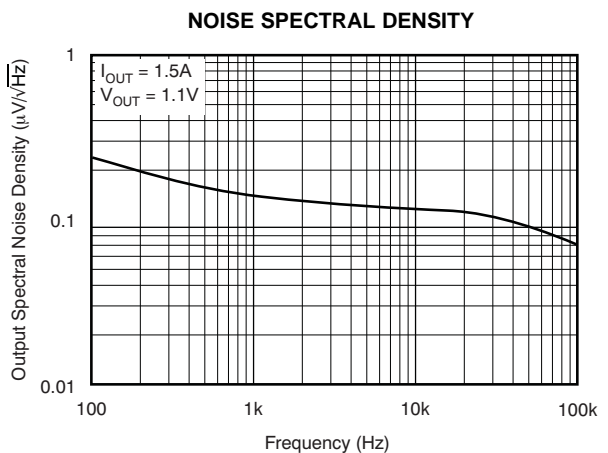

Figure 16.

TYPICAL CHARACTERISTICS (continued)

At $T_J = +25^\circ\text{C}$, $V_{OUT} = 1.5\text{V}$, $V_{IN} = V_{OUT(\text{TYP})} + 0.3\text{V}$, $V_{BIAS} = 3.3\text{V}$, $I_{OUT} = 50\text{mA}$, $EN = V_{IN}$, $C_{IN} = 1\mu\text{F}$, $C_{BIAS} = 4.7\mu\text{F}$, and $C_{OUT} = 10\mu\text{F}$, unless otherwise noted.

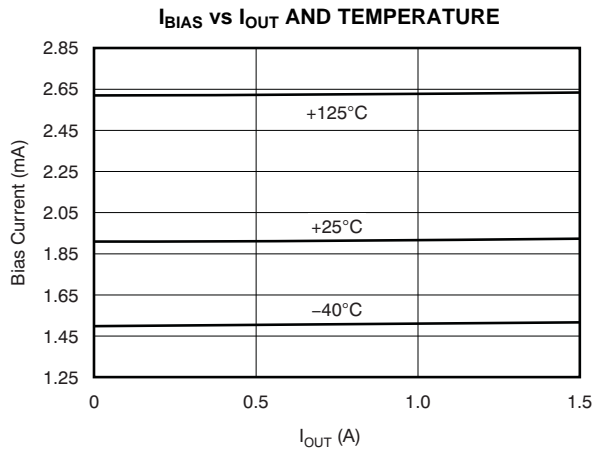

Figure 17.

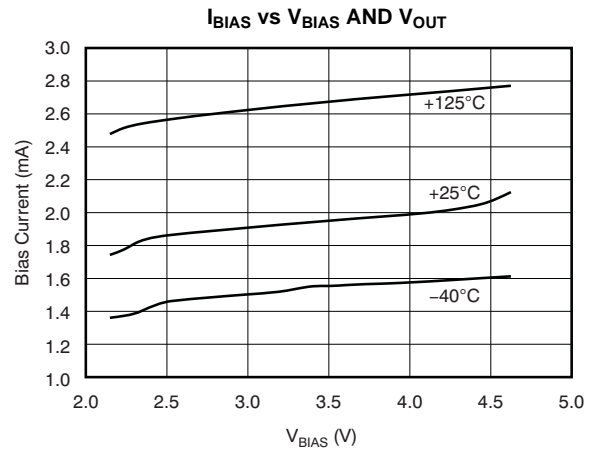

Figure 18.

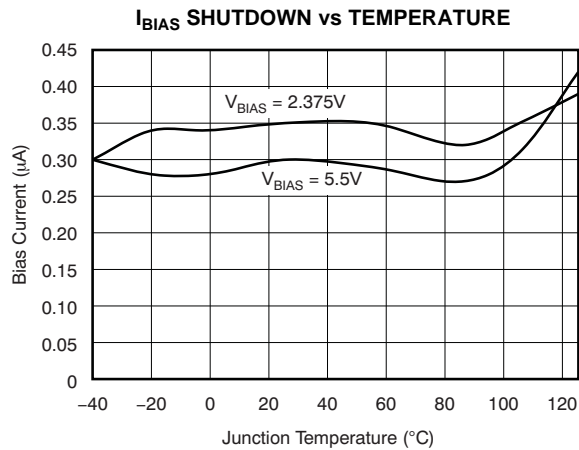

Figure 19.

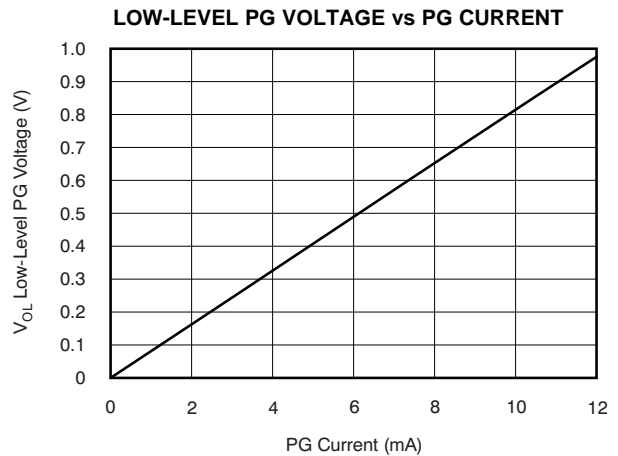

Figure 20.

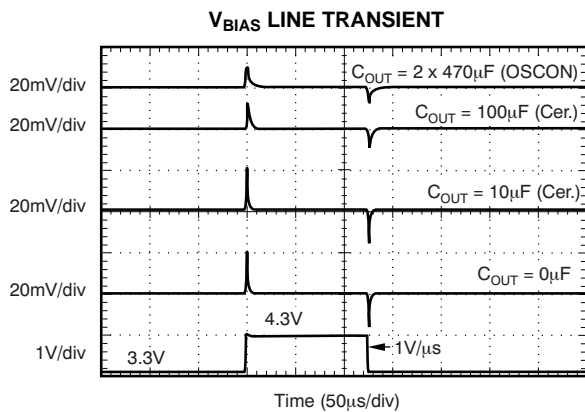

Figure 21.

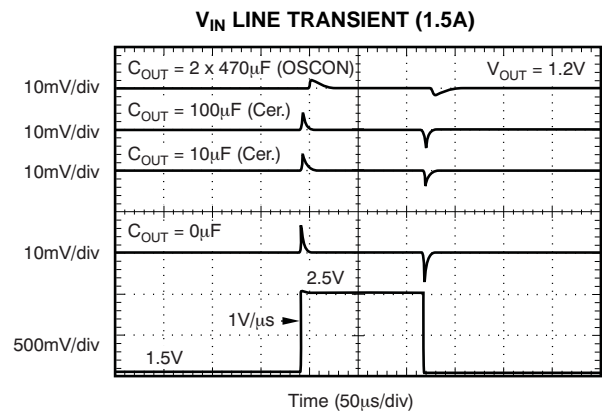

Figure 22.

TYPICAL CHARACTERISTICS (continued)

At $T_J = +25^\circ\text{C}$, $V_{OUT} = 1.5\text{V}$, $V_{IN} = V_{OUT(\text{TYP})} + 0.3\text{V}$, $V_{BIAS} = 3.3\text{V}$, $I_{OUT} = 50\text{mA}$, $EN = V_{IN}$, $C_{IN} = 1\mu\text{F}$, $C_{BIAS} = 4.7\mu\text{F}$, and $C_{OUT} = 10\mu\text{F}$, unless otherwise noted.

OUTPUT LOAD TRANSIENT RESPONSE

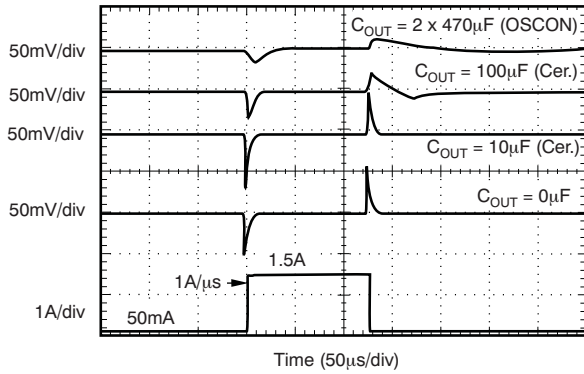

Figure 23.

TRACKING RESPONSE

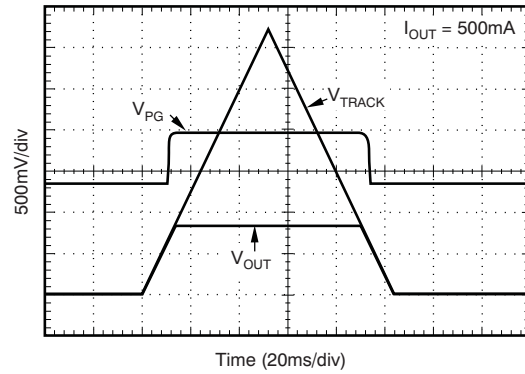

Figure 24.

POWER-UP/POWER-DOWN

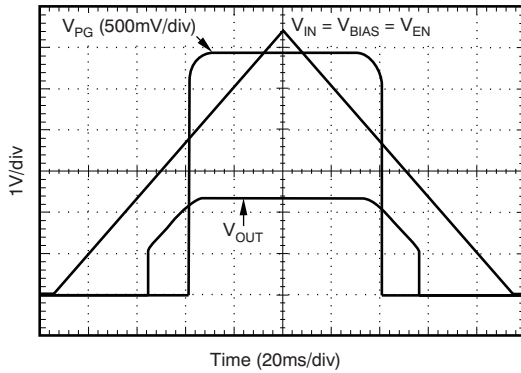

Figure 25.

TURN-ON RESPONSE—QFN PACKAGE

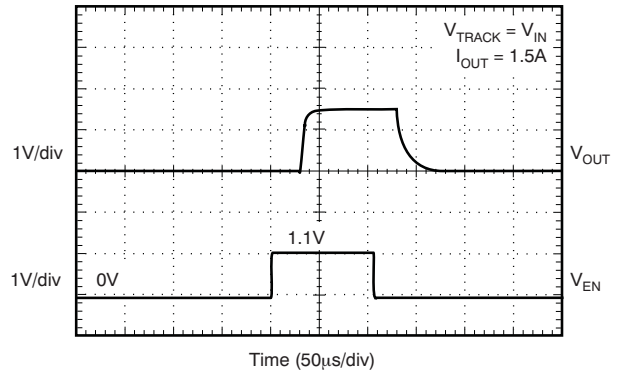

Figure 26.

OUTPUT SHORT-CIRCUIT RECOVERY

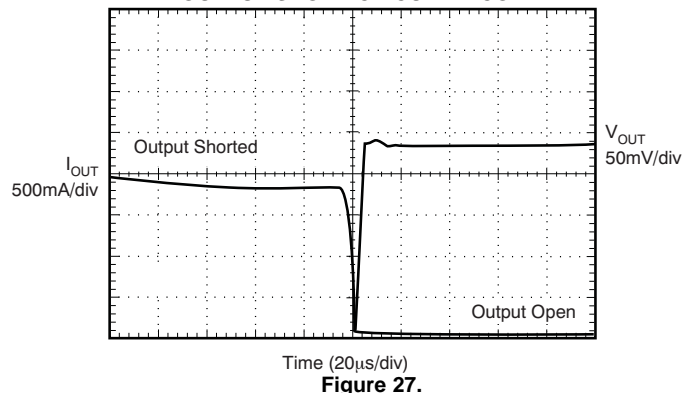

Figure 27.

APPLICATION INFORMATION

The TPS743xx belongs to a family of new generation ultra-low dropout regulators that feature soft-start and tracking capabilities. These regulators use a low current bias input to power all internal control circuitry, allowing the NMOS pass transistor to regulate very low input and output voltages.

The use of an NMOS-pass FET offers several critical advantages for many applications. Unlike a PMOS topology device, the output capacitor has little effect on loop stability. This architecture allows the TPS743xx to be stable with any or even no output capacitor. Transient response is also superior to PMOS topologies, particularly for low V_{IN} applications.

The TPS743xx features a TRACK pin that allows the output to track an external supply. This feature is useful in minimizing the stress on ESD structures that are present between the CORE and I/O power pins of many processors. A power-good (PG) output is also available to allow supply monitoring and sequencing of follow-on supplies. To control the output turn-on, an enable (EN) pin with hysteresis and deglitch is provided to allow slow-ramping signals to be utilized for sequencing the device. The low V_{IN} and V_{OUT} capability allows for inexpensive, easy-to-design, and efficient linear regulation between the multiple supply voltages often present in processor intensive systems.

ADJUSTABLE VOLTAGE PART AND SETTING

Figure 28 is a typical application circuit for the TPS74301 adjustable device.

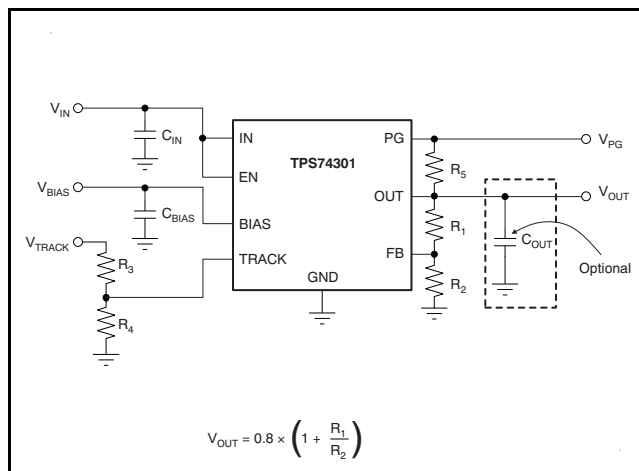

Figure 28. Typical Application Circuit for the TPS74301 (Adjustable Version)

R_1 and R_2 can be calculated for any output voltage using the formula shown in Figure 28. Refer to Table 1 for sample resistor values of common output voltages. In order to achieve the maximum accuracy specifications, R_2 should be $\leq 4.99k\Omega$.

FIXED VOLTAGE AND SENSE PIN

Figure 29 illustrates a typical application circuit for the TPS743xx fixed output device.

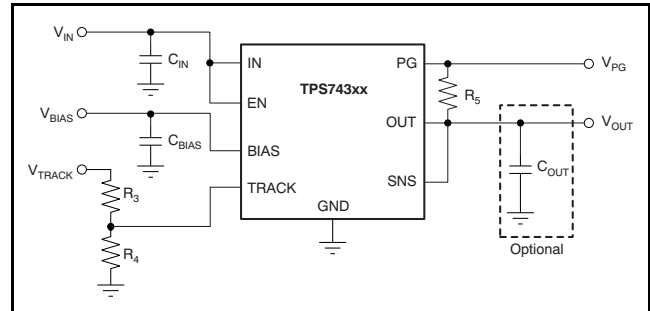

Figure 29. Typical Application Circuit for the TPS743xx (Fixed Voltage)

A fixed voltage version of the TPS743xx has a sense pin (SNS) so that the device can monitor its output voltage at the load device pin(s) as closely as possible. Unlike other TI fixed-voltage LDOs, however, this pin must **not** be left floating; it **must** be connected to an output node. See the TI application report, *Ultimate Regulation of with Fixed Output Versions of the TPS742xx, TPS743xx, and TPS744xx* (literature number [SBVA024](#)), available for download from the TI web site.

INPUT, OUTPUT, AND BIAS CAPACITOR REQUIREMENTS

The device does not require any output capacitor for stability. If an output capacitor is needed, the device is designed to be stable for all available types and values of output capacitance. The device is also stable with multiple capacitors in parallel, of any type or value.

The capacitance required on the IN and BIAS pins is strongly dependent on the input supply source impedance. To counteract any inductance in the input, the minimum recommended capacitor for V_{IN} and V_{BIAS} is $1\mu\text{F}$. If V_{IN} and V_{BIAS} are connected to the same supply, the recommended minimum capacitor for V_{BIAS} is $4.7\mu\text{F}$. Good quality, low ESR capacitors should be used on the input; ceramic X5R and X7R capacitors are preferred. These capacitors should be placed as close the pins as possible for optimum performance.

TRANSIENT RESPONSE

The TPS743xx was designed to have transient response within 5% for most applications without any output capacitor. In some cases, the transient response may be limited by the transient response of the input supply. This limitation is especially true in applications where the difference between the input and output is less than 300mV. In this case, adding additional input capacitance improves the transient response much more than just adding additional output capacitance would do. With a solid input supply, adding additional output capacitance reduces undershoot and overshoot during a transient at the expense of a slightly longer V_{OUT} recovery time. Refer to [Figure 23](#) in the [Typical Characteristics](#) section. Since the TPS743xx is stable without an output capacitor, many applications may allow for little or no capacitance at the LDO output. For these applications, local bypass capacitance for the device under power may be sufficient to meet the transient requirements of the application. This design reduces the total solution cost by avoiding the need to use expensive high-value capacitors at the LDO output.

DROPOUT VOLTAGE

The TPS743xx offers industry-leading dropout performance, making it well-suited for high-current low V_{IN} /low V_{OUT} applications. The extremely low dropout of the TPS743xx allows the device to be used instead of a DC/DC converter and still achieve good efficiencies. This efficiency allows users to rethink the power architecture for their applications to find the smallest, simplest, and lowest cost solution.

There are two different specifications for dropout voltage with the TPS743xx. The first specification (as shown in [Figure 30](#)) is referred to as V_{IN} Dropout and is for users wishing to apply an external bias voltage to achieve low dropout. This specification assumes that V_{BIAS} is at least 1.62V above V_{OUT} , which is the case for V_{BIAS} when powered by a 3.3V rail with 5% tolerance and with $V_{OUT} = 1.5V$. If V_{BIAS} is higher than $3.3V \times 0.95$ or V_{OUT} is less than 1.5V, V_{IN} dropout is less than specified.

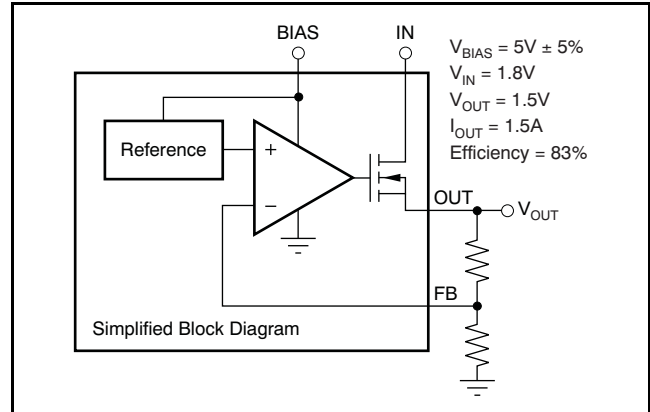

Figure 30. Typical Application of the TPS743xx Using an Auxiliary Bias Rail

The second specification (shown in [Figure 31](#)), referred to as V_{BIAS} Dropout, is for users who wish to tie IN and BIAS together. This option allows the device to be used in applications where an auxiliary bias voltage is unavailable or low dropout is not required. Dropout is limited by BIAS in these applications because V_{BIAS} provides the gate drive to the pass FET, and therefore must be 1.4V above V_{OUT} . Because of this usage, IN and BIAS tied together easily consume huge power. Pay attention not to exceed the power rating of the IC package.

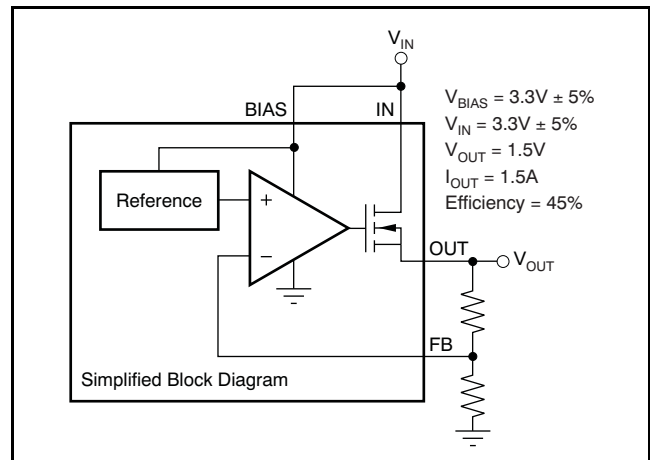

Figure 31. Typical Application of the TPS743xx Without an Auxiliary Bias

PROGRAMMABLE SEQUENCING WITH TRACK

The TPS743xx features a track pin that allows the output to track an external supply at start-up. While the TRACK input is below 0.8V, the error amplifier regulates the FB pin to the TRACK input. Properly choosing the resistor divider network (R_1 and R_2) as shown in Figure 32 enables the regulator output to track the external supply to obtain a simultaneous or ratiometric start-up. Once the TRACK input reaches 0.8V, the error amplifier regulates the FB pin to the 0.8V internal reference. Further increases to the TRACK input have no effect.

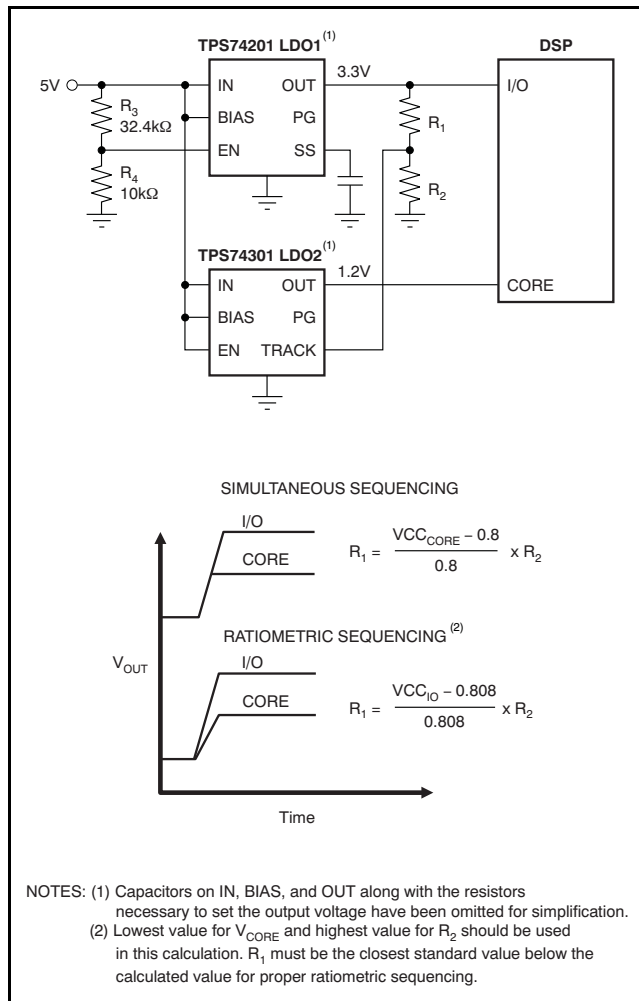

Figure 32. Various Sequencing Methods Using the TRACK Pin

The maximum recommended value for R_2 is 100kΩ. Once R_2 is selected, R_1 is calculated using one of the equations given in Figure 32.

SEQUENCING REQUIREMENTS

The device can have V_{IN} , V_{BIAS} , V_{EN} , and V_{TRACK} sequenced in any order without causing damage to the device. However, for the track function to work as intended, certain sequencing rules must be applied. V_{BIAS} must be present and the device enabled before the track signal starts to ramp. V_{IN} should ramp up faster than the external supply being tracked so that the tracking signal will not drive the device into V_{IN} dropout as V_{OUT} ramps up. The preferred method to sequence the tracking device is to have V_{IN} , V_{BIAS} , and V_{EN} above the minimum required voltages before enabling the master supply to initiate the startup sequence. This method is illustrated in Figure 32. Resistors R_3 and R_4 disable the master supply until the input voltage is above 3.52V (typical).

If the TRACK pin is not needed it should be connected to V_{IN} . Configured in this way, the device starts up typically within 40μs, which may result in large inrush current that could cause the input supply to droop. If soft-start is needed, consider the TPS742xx or TPS744xx devices.

NOTE: When V_{BIAS} and V_{EN} are present and V_{IN} is not supplied, this device outputs approximately 50μA of current from OUT. Although this condition will not cause any damage to the device, the output current may charge up the OUT node if total resistance between OUT and GND (including external feedback resistors) is greater than 10kΩ.

ENABLE/SHUTDOWN

The enable (EN) pin is active high and is compatible with standard digital signaling levels. V_{EN} below 0.4V turns the regulator off, while V_{EN} above 1.1V turns the regulator on. Unlike many regulators, the enable circuitry has hysteresis and deglitching for use with relatively slow-ramping analog signals. This configuration allows the TPS743xx to be enabled by connecting the output of another supply to the EN pin. The enable circuitry typically has 50mV of hysteresis and a deglitch circuit to help avoid on-off cycling because of small glitches in the V_{EN} signal.

The enable threshold is typically 0.8V and varies with temperature and process variations. Temperature variation is approximately $-1\text{mV}/^\circ\text{C}$; therefore, process variation accounts for most of the variation in the enable threshold. If precise turn-on timing is required, a fast rise-time signal should be used to enable the TPS743xx.

If not used, EN can be connected to either IN or BIAS. If EN is connected to IN, it should be connected as close as possible to the largest capacitance on the input to prevent voltage droops on that line from triggering the enable circuit.

POWER-GOOD (QFN Package Only)

The power-good (PG) pin is an open-drain output and can be connected to any 5.5V or lower rail through an external pull-up resistor. This pin requires at least 1.1V on V_{BIAS} in order to have a valid output. The PG output is high-impedance when V_{OUT} is greater than $V_{IT} + V_{HYS}$. If V_{OUT} drops below V_{IT} or if V_{BIAS} drops below 1.9V, the open-drain output turns on and pulls the PG output low. The PG pin also asserts when the device is disabled. The recommended operating condition of PG pin sink current is up to 1mA, so the pull-up resistor for PG should be in the range of 10k Ω to 1M Ω . PG is only provided on the QFN package. If output voltage monitoring is not needed, the PG pin can be left floating.

INTERNAL CURRENT LIMIT

The TPS743xx features a factory-trimmed, accurate current limit that is flat over temperature and supply voltage. The current limit allows the device to supply surges of up to 1.8A and maintain regulation. The current limit responds in about 10 μs to reduce the

current during a short-circuit fault. Recovery from a short-circuit condition is well-controlled and results in very little output overshoot when the load is removed. See [Figure 27](#) in the [Typical Characteristics](#) section for output short-circuit recovery performance.

The internal current limit protection circuitry of the TPS743xx is designed to protect against overload conditions. It is not intended to allow operation above the rated current of the device. Continuously running the TPS743xx above the rated current degrades device reliability.

THERMAL PROTECTION

Thermal protection disables the output when the junction temperature rises to approximately $+155^\circ\text{C}$, allowing the device to cool. When the junction temperature cools to approximately $+140^\circ\text{C}$, the output circuitry is enabled. Depending on power dissipation, thermal resistance, and ambient temperature the thermal protection circuit may cycle on and off. This cycling limits the dissipation of the regulator, protecting it from damage as a result of overheating.

Activation of the thermal protection circuit indicates excessive power dissipation or inadequate heatsinking. For reliable operation, junction temperature should be limited to $+125^\circ\text{C}$ maximum. To estimate the margin of safety in a complete design (including heatsink), increase the ambient temperature until thermal protection is triggered; use worst-case loads and signal conditions. For good reliability, thermal protection should trigger at least $+30^\circ\text{C}$ above the maximum expected ambient condition of the application. This condition produces a worst-case junction temperature of $+125^\circ\text{C}$ at the highest expected ambient temperature and worst-case load.

The internal protection circuitry of the TPS743xx is designed to protect against overload conditions. It is not intended to replace proper heatsinking. Continuously running the TPS743xx into thermal shutdown degrades device reliability.

LAYOUT RECOMMENDATIONS AND POWER DISSIPATION

An optimal layout can greatly improve transient performance, PSRR, and noise. To minimize the voltage droop on the input of the device during load transients, the capacitance on IN and BIAS should be connected as close as possible to the device. This capacitance also minimizes the effects of parasitic inductance and resistance of the input source and can therefore improve stability. To achieve optimal transient performance and accuracy, the top side of R₁ in [Figure 28](#) should be connected as close as possible to the load. If BIAS is connected to IN, it is recommended to connect BIAS as close to the sense point of the input supply as possible. This connection minimizes the voltage droop on BIAS during transient conditions and can improve the turn-on response.

Knowing the device power dissipation and proper sizing of the thermal plane that is connected to the tab or pad is critical to avoiding thermal shutdown and ensuring reliable operation. Power dissipation of the device depends on input voltage and load conditions, and can be calculated using [Equation 1](#):

$$P_D = (V_{IN} - V_{OUT}) \times I_{OUT} \quad (1)$$

Power dissipation can be minimized and greater efficiency can be achieved by using the lowest possible input voltage necessary to achieve the required output voltage regulation.

On the QFN (RGW) package, the primary conduction path for heat is through the exposed pad to the printed circuit board (PCB). The pad can be connected to ground or be left floating; however, it should be attached to an appropriate amount of copper PCB area to ensure the device will not overheat. On the DPAK (KTW) package, the primary conduction path for heat is through the tab to the PCB. That tab should be connected to ground.

The maximum junction-to-ambient thermal resistance depends on the maximum ambient temperature, maximum device junction temperature, and power dissipation of the device and can be calculated using [Equation 2](#):

$$R_{\theta JA} = \frac{(+125^{\circ}\text{C} - T_A)}{P_D} \quad (2)$$

Knowing the maximum R_{θJA}, the minimum amount of PCB copper area needed for appropriate heatsinking can be estimated using [Figure 33](#).

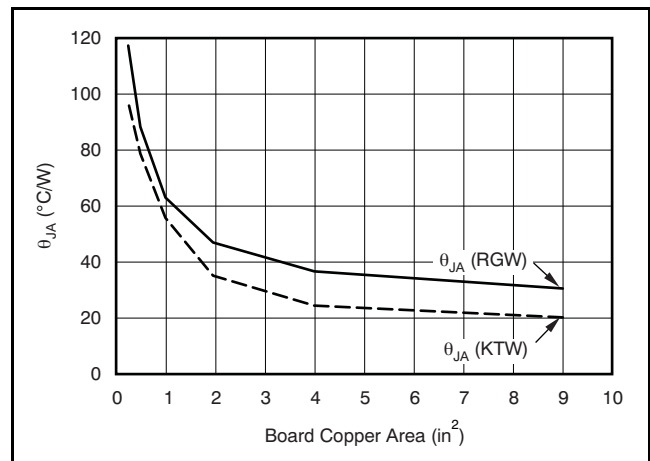

Note: θ_{JA} value at board size of 9in² (that is, 3in x 3in) is a JEDEC standard.

Figure 33. θ_{JA} vs Board Size

[Figure 33](#) shows the variation of θ_{JA} as a function of ground plane copper area in the board. It is intended only as a guideline to demonstrate the effects of heat spreading in the ground plane and should not be used to estimate actual thermal performance in real application environments.

NOTE: When the device is mounted on an application PCB, it is strongly recommended to use Ψ_{JT} and Ψ_{JB}, as explained in the [Estimating Junction Temperature](#) section.

ESTIMATING JUNCTION TEMPERATURE

Using the thermal metrics Ψ_{JT} and Ψ_{JB} , shown in the *Thermal Information* table, the junction temperature can be estimated with corresponding formulas (given in Equation 3). For backwards compatibility, an older $\theta_{JC, Top}$ parameter is listed as well.

$$\Psi_{JT}: T_J = T_T + \Psi_{JT} \cdot P_D$$

$$\Psi_{JB}: T_J = T_B + \Psi_{JB} \cdot P_D \quad (3)$$

Where P_D is the power dissipation shown by Equation 1, T_T is the temperature at the center-top of the IC package, and T_B is the PCB temperature measured 1mm away from the IC package *on the PCB surface* (as Figure 34 shows).

NOTE: Both T_T and T_B can be measured on actual application boards using a thermo-gun (an infrared thermometer).

For more information about measuring T_T and T_B , see the application note *Using New Thermal Metrics (SBVA025)*, available for download at www.ti.com.

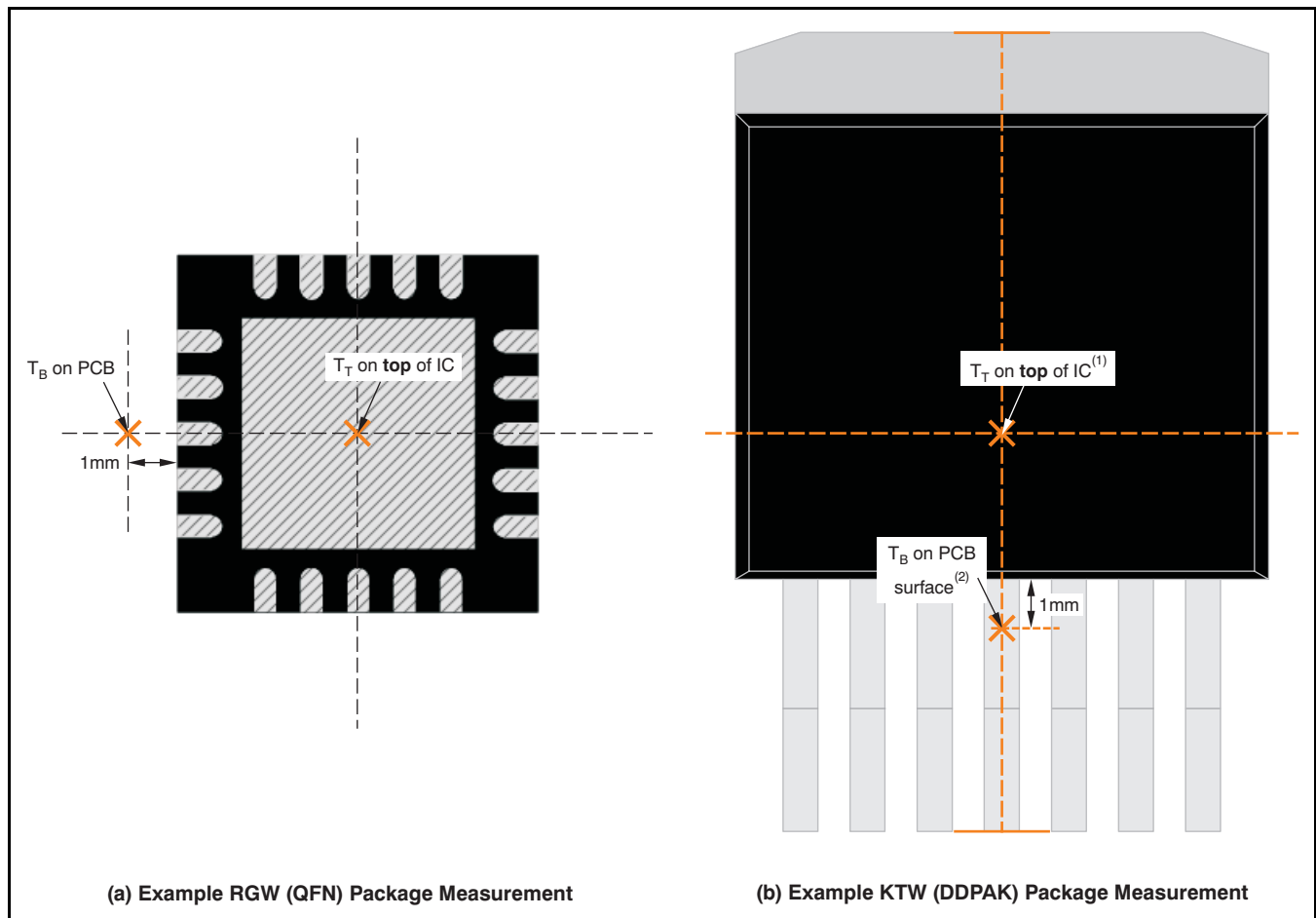

(1) T_T is measured at the center of both the X- and Y-dimensional axes.

(2) T_B is measured **below** the package lead **on the PCB surface**.

Figure 34. Measuring Points for T_T and T_B

Compared with θ_{JA} , the thermal metrics Ψ_{JT} and Ψ_{JB} are less independent of board size, but they do have a small dependency. Figure 35 shows characteristic performance of Ψ_{JT} and Ψ_{JB} versus board size.

Looking at Figure 35, the RGW package thermal performance has negligible dependency on board size. The KTW package, however, does have a measurable dependency on board size. This dependency exists because the package shape is not point-symmetric to an IC center. In the KTW package, for example (see Figure 34), silicon is not beneath the measuring point of T_T which is the center of the X and Y dimension, so that Ψ_{JT} has a dependency. Also, because of that non-point-symmetry, device heat distribution on the PCB is not point-symmetric, either, so that Ψ_{JB} has a dependency.

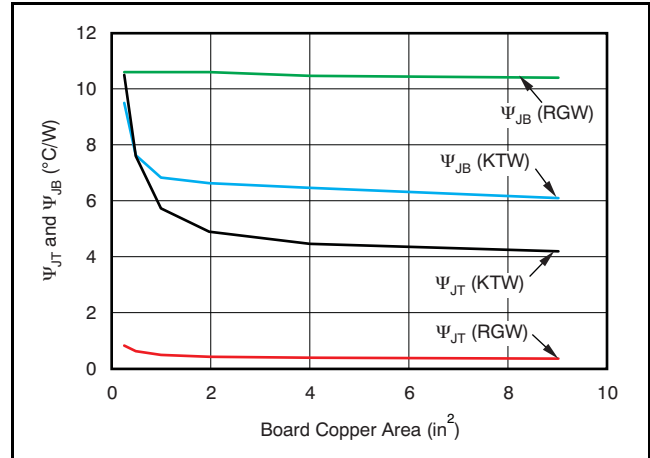

Figure 35. Ψ_{JT} and Ψ_{JB} vs Board Size

For a more detailed discussion of why TI does not recommend using $\theta_{JC,Top}$ to determine thermal characteristics, refer to the application note *Using New Thermal Metrics* (SBVA025), available for download at www.ti.com. Also, refer to the application note *IC Package Thermal Metrics* (SPRA953) (also available on the TI web site) for further information.

REVISION HISTORY

NOTE: Page numbers for previous revisions may differ from page numbers in the current version.

Changes from Revision J (December, 2009) to Revision K	Page
• Replaced the <i>Dissipation Ratings</i> table with the <i>Thermal Information</i> table	3
• Revised <i>Layout Recommendations and Power Dissipation</i> section	16
• Revised <i>Estimating Junction Temperature</i> section	17

Changes from Revision I (August, 2009) to Revision J	Page
• Changed last sentence of <i>Layout Recommendations and Power Dissipation</i> section; added Figure 33	16
• Added <i>Estimating Junction Temperature</i> section	17
• Deleted (previously numbered) Figure 33 through Figure 37	18

PACKAGING INFORMATION

Orderable Device	Status (1)	Package Type	Package Drawing	Pins	Package Qty	Eco Plan (2)	Lead/Ball Finish (6)	MSL Peak Temp (3)	Op Temp (°C)	Device Marking (4/5)	Samples
TPS74301KTWR	ACTIVE	DDPAK/ TO-263	KTW	7	500	Green (RoHS & no Sb/Br)	CU SN Call TI	Level-3-245C-168 HR	-40 to 85	TPS74301	Samples
TPS74301RGWR	ACTIVE	VQFN	RGW	20	3000	Green (RoHS & no Sb/Br)	CU NIPDAU	Level-2-260C-1 YEAR	-40 to 85	TPS 74301	Samples
TPS74301RGWRG4	ACTIVE	VQFN	RGW	20	3000	Green (RoHS & no Sb/Br)	CU NIPDAU	Level-2-260C-1 YEAR	-40 to 85	TPS 74301	Samples
TPS74301RGWT	ACTIVE	VQFN	RGW	20	250	Green (RoHS & no Sb/Br)	CU NIPDAU	Level-2-260C-1 YEAR	-40 to 85	TPS 74301	Samples
TPS74301RGWTG4	ACTIVE	VQFN	RGW	20	250	Green (RoHS & no Sb/Br)	CU NIPDAU	Level-2-260C-1 YEAR	-40 to 85	TPS 74301	Samples

(1) The marketing status values are defined as follows:

ACTIVE: Product device recommended for new designs.

LIFEBUY: TI has announced that the device will be discontinued, and a lifetime-buy period is in effect.

NRND: Not recommended for new designs. Device is in production to support existing customers, but TI does not recommend using this part in a new design.

PREVIEW: Device has been announced but is not in production. Samples may or may not be available.

OBSELETE: TI has discontinued the production of the device.

(2) **RoHS:** TI defines "RoHS" to mean semiconductor products that are compliant with the current EU RoHS requirements for all 10 RoHS substances, including the requirement that RoHS substance do not exceed 0.1% by weight in homogeneous materials. Where designed to be soldered at high temperatures, "RoHS" products are suitable for use in specified lead-free processes. TI may reference these types of products as "Pb-Free".

RoHS Exempt: TI defines "RoHS Exempt" to mean products that contain lead but are compliant with EU RoHS pursuant to a specific EU RoHS exemption.

Green: TI defines "Green" to mean the content of Chlorine (Cl) and Bromine (Br) based flame retardants meet JS709B low halogen requirements of <=1000ppm threshold. Antimony trioxide based flame retardants must also meet the <=1000ppm threshold requirement.

(3) MSL, Peak Temp. - The Moisture Sensitivity Level rating according to the JEDEC industry standard classifications, and peak solder temperature.

(4) There may be additional marking, which relates to the logo, the lot trace code information, or the environmental category on the device.

(5) Multiple Device Markings will be inside parentheses. Only one Device Marking contained in parentheses and separated by a "-" will appear on a device. If a line is indented then it is a continuation of the previous line and the two combined represent the entire Device Marking for that device.

(6) Lead/Ball Finish - Orderable Devices may have multiple material finish options. Finish options are separated by a vertical ruled line. Lead/Ball Finish values may wrap to two lines if the finish value exceeds the maximum column width.

Important Information and Disclaimer:The information provided on this page represents TI's knowledge and belief as of the date that it is provided. TI bases its knowledge and belief on information provided by third parties, and makes no representation or warranty as to the accuracy of such information. Efforts are underway to better integrate information from third parties. TI has taken and continues to take reasonable steps to provide representative and accurate information but may not have conducted destructive testing or chemical analysis on incoming materials and chemicals. TI and TI suppliers consider certain information to be proprietary, and thus CAS numbers and other limited information may not be available for release.

In no event shall TI's liability arising out of such information exceed the total purchase price of the TI part(s) at issue in this document sold by TI to Customer on an annual basis.

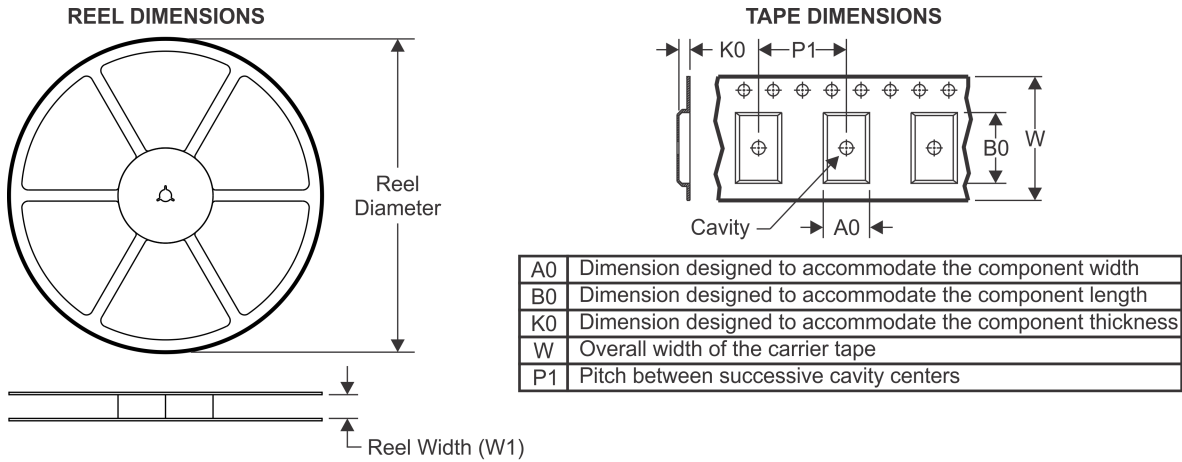
TAPE AND REEL INFORMATION

QUADRANT ASSIGNMENTS FOR PIN 1 ORIENTATION IN TAPE

*All dimensions are nominal

Device	Package Type	Package Drawing	Pins	SPQ	Reel Diameter (mm)	Reel Width W1 (mm)	A0 (mm)	B0 (mm)	K0 (mm)	P1 (mm)	W (mm)	Pin1 Quadrant
TPS74301KTWR	DDPAK/ TO-263	KTW	7	500	330.0	24.4	10.6	15.6	4.9	16.0	24.0	Q2
TPS74301RGWR	VQFN	RGW	20	3000	330.0	12.4	5.3	5.3	1.5	8.0	12.0	Q2
TPS74301RGWT	VQFN	RGW	20	250	180.0	12.4	5.3	5.3	1.5	8.0	12.0	Q2

TAPE AND REEL BOX DIMENSIONS

*All dimensions are nominal

Device	Package Type	Package Drawing	Pins	SPQ	Length (mm)	Width (mm)	Height (mm)
TPS74301KTWR	DDPAK/TO-263	KTW	7	500	367.0	367.0	45.0
TPS74301RGWR	VQFN	RGW	20	3000	367.0	367.0	35.0
TPS74301RGWT	VQFN	RGW	20	250	210.0	185.0	35.0

KTW (R-PSFM-G7)

PLASTIC FLANGE-MOUNT

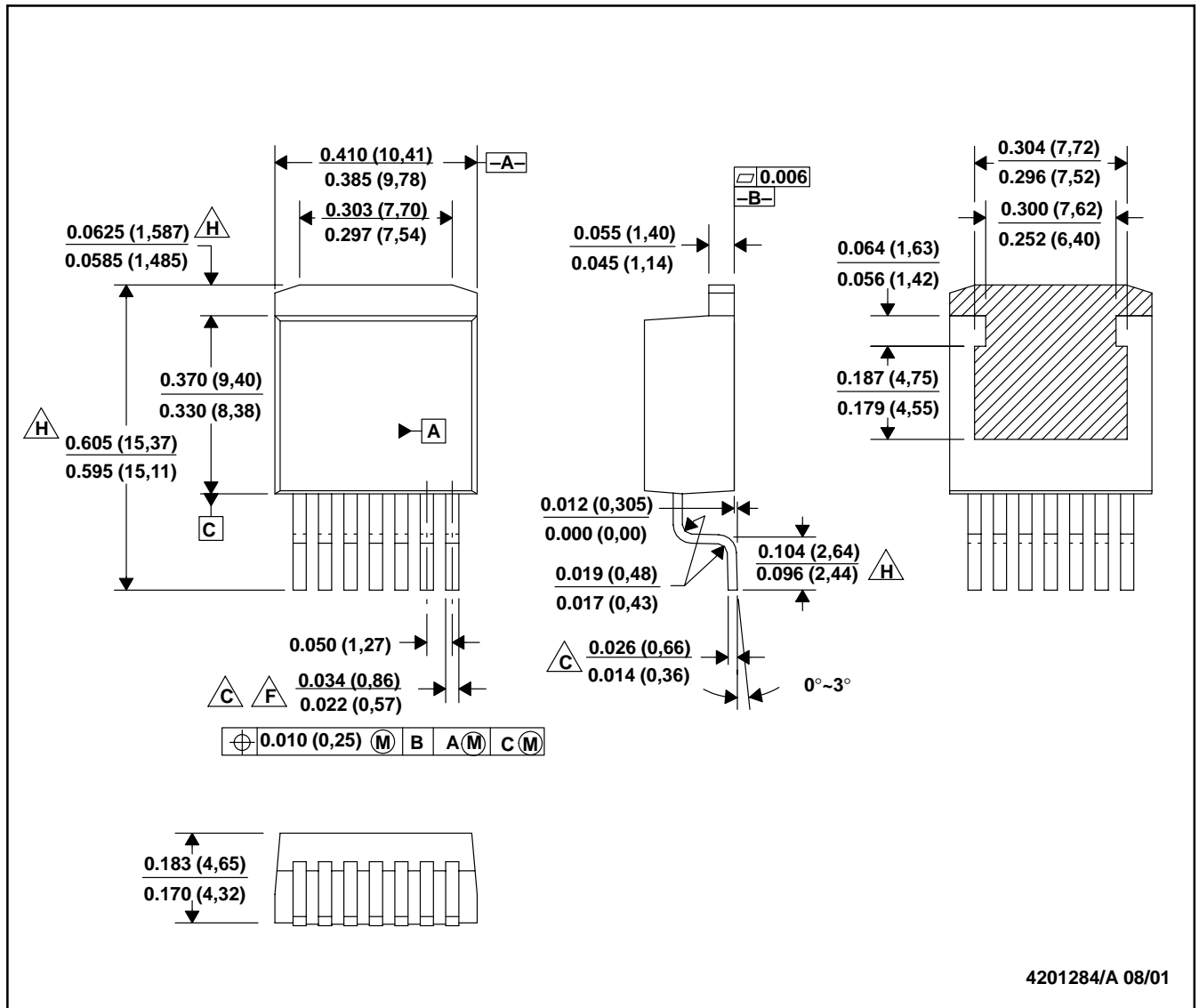

- NOTES: A. All linear dimensions are in inches (millimeters).
 B. This drawing is subject to change without notice.
 $\triangle C$. Lead width and height dimensions apply to the plated lead.
 D. Leads are not allowed above the Datum B.
 E. Stand-off height is measured from lead tip with reference to Datum B.
 $\triangle F$. Lead width dimension does not include dambar protrusion. Allowable dambar protrusion shall not cause the lead width to exceed the maximum dimension by more than 0.003".
 G. Cross-hatch indicates exposed metal surface.
 $\triangle H$. Falls within JEDEC MO-169 with the exception of the dimensions indicated.

RGW (S-PVQFN-N20)

PLASTIC QUAD FLATPACK NO-LEAD

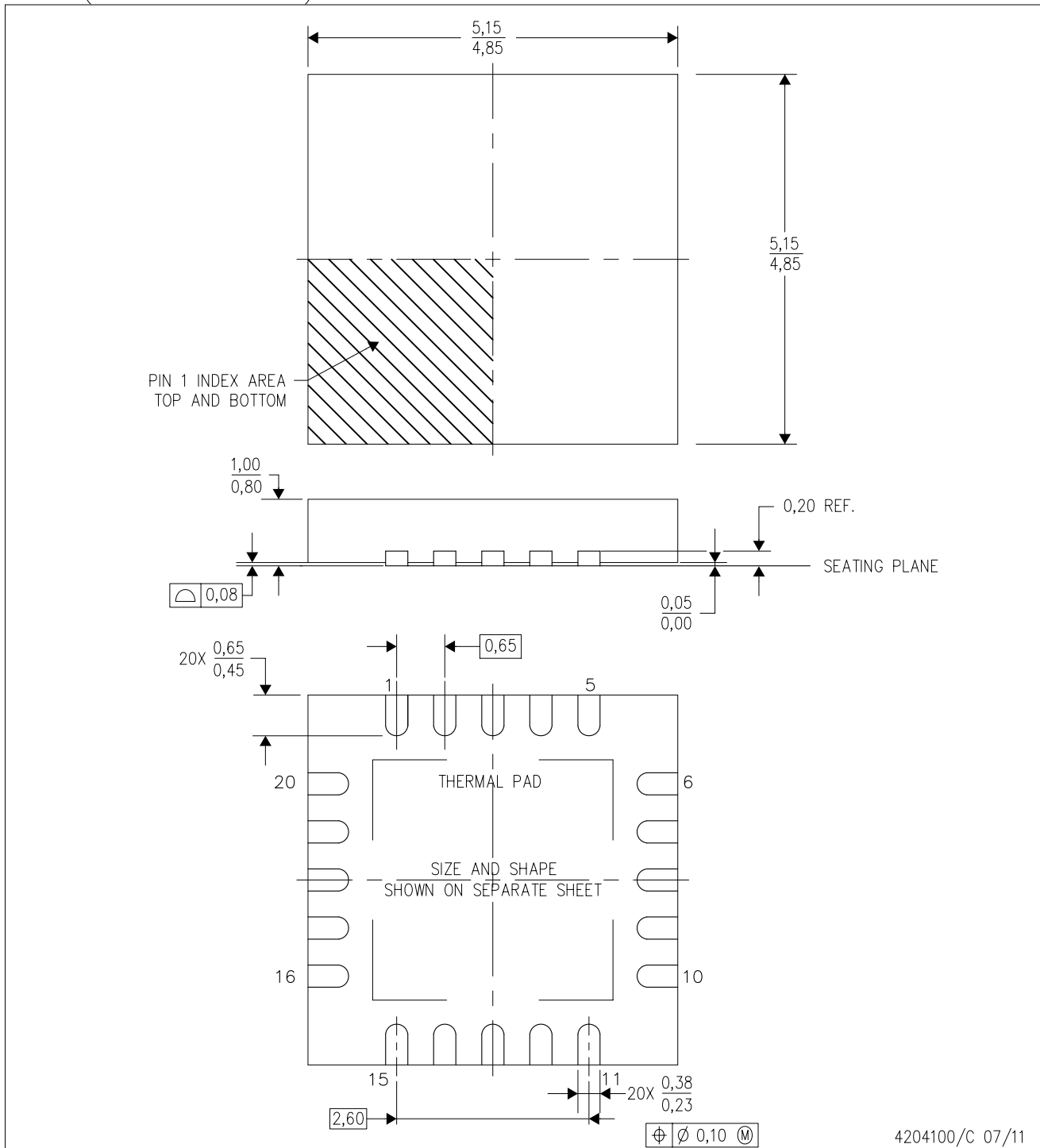

4204100/C 07/11

- NOTES:
- All linear dimensions are in millimeters. Dimensioning and tolerancing per ASME Y14.5-1994.
 - This drawing is subject to change without notice.
 - Quad Flat pack, No-leads (QFN) package configuration
 - The package thermal pad must be soldered to the board for thermal and mechanical performance.
 - See the additional figure in the Product Data Sheet for details regarding the exposed thermal pad features and dimensions.
 - Falls within JEDEC MO-220.

THERMAL PAD MECHANICAL DATA

RGW (S-PVQFN-N20)

PLASTIC QUAD FLATPACK NO-LEAD

THERMAL INFORMATION

This package incorporates an exposed thermal pad that is designed to be attached directly to an external heatsink. The thermal pad must be soldered directly to the printed circuit board (PCB). After soldering, the PCB can be used as a heatsink. In addition, through the use of thermal vias, the thermal pad can be attached directly to the appropriate copper plane shown in the electrical schematic for the device, or alternatively, can be attached to a special heatsink structure designed into the PCB. This design optimizes the heat transfer from the integrated circuit (IC).

For information on the Quad Flatpack No-Lead (QFN) package and its advantages, refer to Application Report, QFN/SON PCB Attachment, Texas Instruments Literature No. SLUA271. This document is available at www.ti.com.

The exposed thermal pad dimensions for this package are shown in the following illustration.

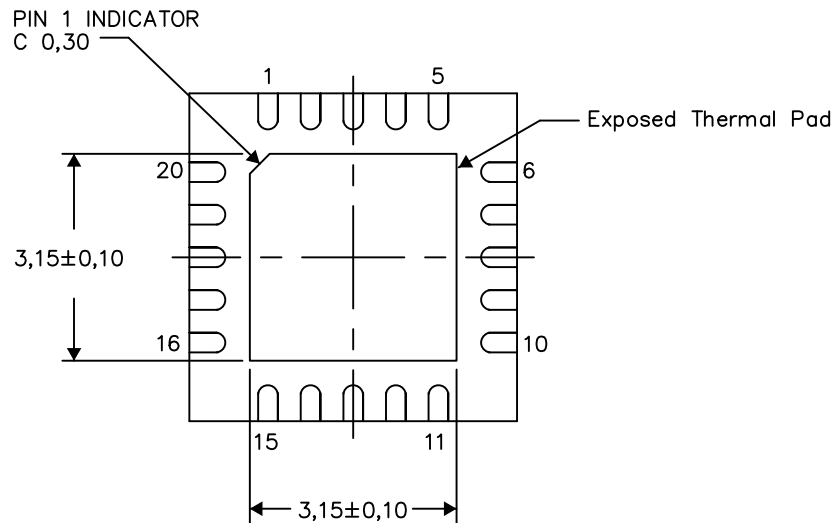

Bottom View

Exposed Thermal Pad Dimensions

4206352-2/M 06/15

NOTE: All linear dimensions are in millimeters

RGW (S-PVQFN-N20)

PLASTIC QUAD FLATPACK NO-LEAD

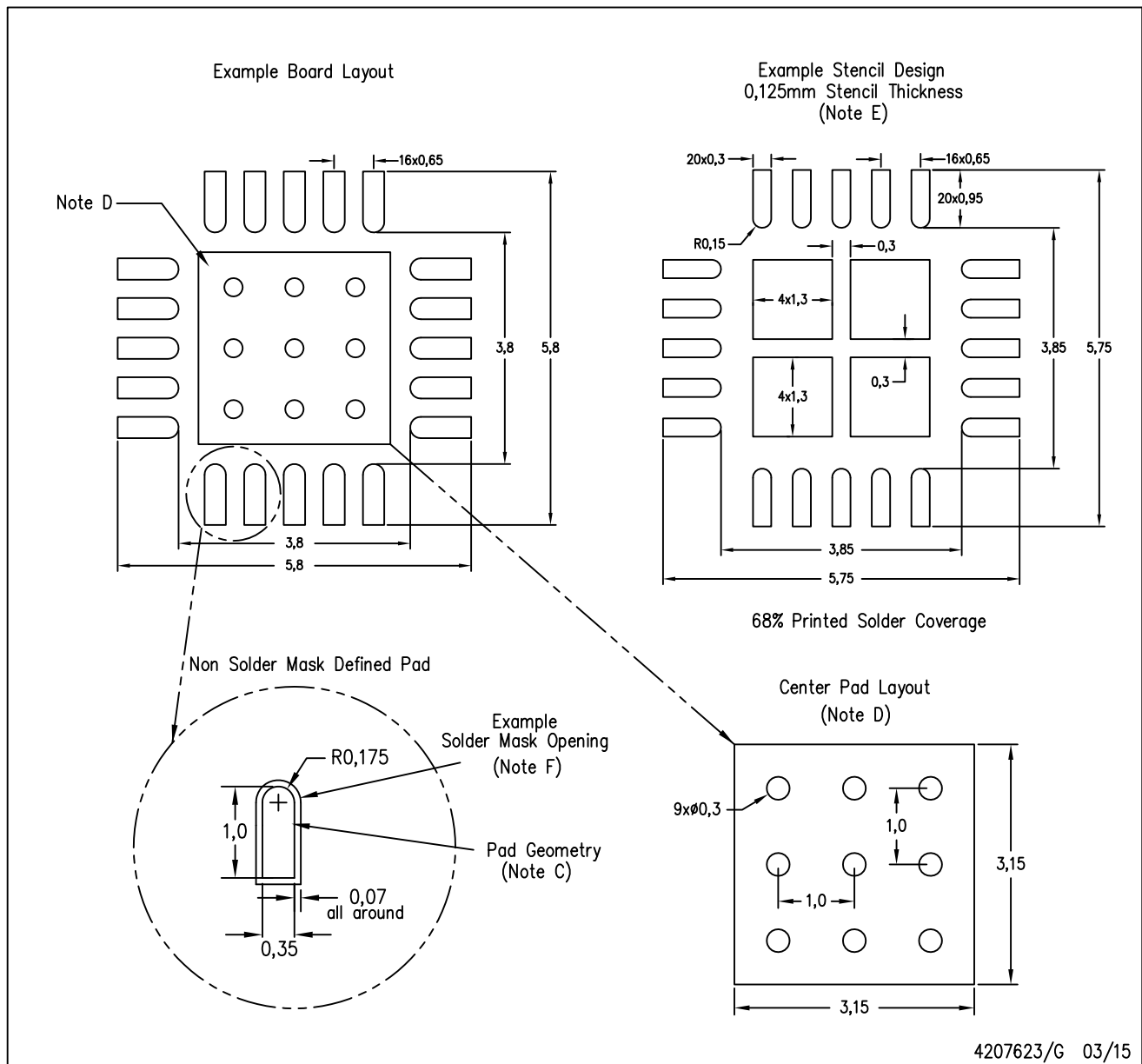

- NOTES:
- All linear dimensions are in millimeters.
 - This drawing is subject to change without notice.
 - Publication IPC-7351 is recommended for alternate designs.
 - This package is designed to be soldered to a thermal pad on the board. Refer to Application Note, QFN Packages, Texas Instruments Literature No. SLUA271, and also the Product Data Sheets for specific thermal information, via requirements, and recommended board layout. These documents are available at www.ti.com <<http://www.ti.com>>.
 - Laser cutting apertures with trapezoidal walls and also rounding corners will offer better paste release. Customers should contact their board assembly site for stencil design recommendations. Refer to IPC 7525 for stencil design considerations.
 - Customers should contact their board fabrication site for solder mask tolerances.

IMPORTANT NOTICE AND DISCLAIMER

TI PROVIDES TECHNICAL AND RELIABILITY DATA (INCLUDING DATASHEETS), DESIGN RESOURCES (INCLUDING REFERENCE DESIGNS), APPLICATION OR OTHER DESIGN ADVICE, WEB TOOLS, SAFETY INFORMATION, AND OTHER RESOURCES "AS IS" AND WITH ALL FAULTS, AND DISCLAIMS ALL WARRANTIES, EXPRESS AND IMPLIED, INCLUDING WITHOUT LIMITATION ANY IMPLIED WARRANTIES OF MERCHANTABILITY, FITNESS FOR A PARTICULAR PURPOSE OR NON-INFRINGEMENT OF THIRD PARTY INTELLECTUAL PROPERTY RIGHTS.

These resources are intended for skilled developers designing with TI products. You are solely responsible for (1) selecting the appropriate TI products for your application, (2) designing, validating and testing your application, and (3) ensuring your application meets applicable standards, and any other safety, security, or other requirements. These resources are subject to change without notice. TI grants you permission to use these resources only for development of an application that uses the TI products described in the resource. Other reproduction and display of these resources is prohibited. No license is granted to any other TI intellectual property right or to any third party intellectual property right. TI disclaims responsibility for, and you will fully indemnify TI and its representatives against, any claims, damages, costs, losses, and liabilities arising out of your use of these resources.

TI's products are provided subject to TI's Terms of Sale (www.ti.com/legal/termsofsale.html) or other applicable terms available either on ti.com or provided in conjunction with such TI products. TI's provision of these resources does not expand or otherwise alter TI's applicable warranties or warranty disclaimers for TI products.

Mailing Address: Texas Instruments, Post Office Box 655303, Dallas, Texas 75265
Copyright © 2019, Texas Instruments Incorporated

Looking for pricing, stock, or lifecycle information?

Click below to explore more details on WIN SOURCE:

 [View TPS74301RGWT on WIN SOURCE](#)

 [Texas Instruments](#) Information

Optimize Your Supply Chain with WIN SOURCE Solutions

-  Global Sourcing Solution
-  Obsolete Management
-  Cost Control Management
-  Shortage Management
-  Alternative Solution
-  Excess Inventory Management