



# THE DATASHEET OF TS321IDBV



## TS321 Low-Power Single Operational Amplifier

### 1 Features

- Wide Power-Supply Range
  - Single Supply from 3 V to 30 V
  - Dual Supply from  $\pm 1.5$  V to  $\pm 15$  V
- Large Output Voltage Swing from 0 V to 3.5 V (Minimum) ( $V_{CC} = 5$  V)
- Low Supply Current at 500  $\mu$ A (Typical)
- Low Input Bias Current at 20 nA (Typical)
- Stable With High Capacitive Loads

### 2 Applications

- Desktop PCs
- HVAC: Heating, Ventilating, and Air Conditioning
- Portable Media Players
- Refrigerators
- Washing Machines: High-End and Low-End

### 3 Description

The TS321 is a bipolar operational amplifier for cost-sensitive applications in which space savings are important.

#### Device Information<sup>(1)</sup>

PART NUMBER	PACKAGE	BODY SIZE (NOM)
TS321	SOIC (8)	4.90 mm x 3.90 mm
	SOT-23 (5)	2.90 mm x 1.60 mm

(1) For all available packages, see the orderable addendum at the end of the data sheet.

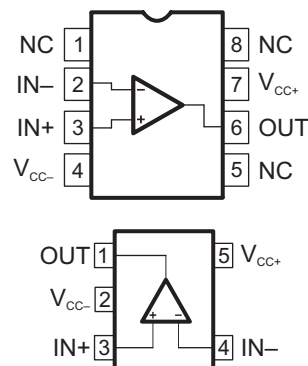

## Table of Contents

<b>1 Features</b> .....	<b>1</b>	7.2 Functional Block Diagram .....	<b>8</b>
<b>2 Applications</b> .....	<b>1</b>	7.3 Feature Description.....	<b>8</b>
<b>3 Description</b> .....	<b>1</b>	7.4 Device Functional Modes.....	<b>9</b>
<b>4 Revision History</b> .....	<b>2</b>	<b>8 Application and Implementation</b> .....	<b>10</b>
<b>5 Pin Configuration and Functions</b> .....	<b>3</b>	8.1 Application Information.....	<b>10</b>
<b>6 Specifications</b> .....	<b>4</b>	8.2 Typical Application .....	<b>10</b>
6.1 Absolute Maximum Ratings .....	<b>4</b>	<b>9 Power Supply Recommendations</b> .....	<b>12</b>
6.2 ESD Ratings.....	<b>4</b>	<b>10 Layout</b> .....	<b>12</b>
6.3 Recommended Operating Conditions.....	<b>4</b>	10.1 Layout Guidelines .....	<b>12</b>
6.4 Thermal Information: TS321 .....	<b>4</b>	10.2 Layout Example .....	<b>12</b>
6.5 Electrical Characteristics.....	<b>5</b>	<b>11 Device and Documentation Support</b> .....	<b>14</b>
6.6 Typical Characteristics .....	<b>7</b>	11.1 Documentation Support .....	<b>14</b>
<b>7 Detailed Description</b> .....	<b>8</b>	11.2 Trademarks .....	<b>14</b>
7.1 Overview .....	<b>8</b>	11.3 Electrostatic Discharge Caution.....	<b>14</b>
		11.4 Glossary .....	<b>14</b>

## 4 Revision History

### Changes from Revision C (April 2015) to Revision D Page

- Corrected SOIC package pinout quantity from "SOIC (14)" to "SOIC (8)" in *Device Information* table ..... **1**

### Changes from Revision B (December 2013) to Revision C Page

- Added *Pin Configuration and Functions* section, *ESD Ratings* table, *Feature Description* section, *Device Functional Modes*, *Application and Implementation* section, *Power Supply Recommendations* section, *Layout* section, *Device and Documentation Support* section, and *Mechanical, Packaging, and Orderable Information* section ..... **1**

## 5 Pin Configuration and Functions

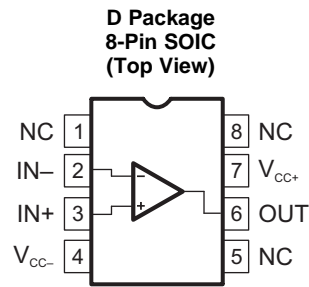

NC - no internal connection

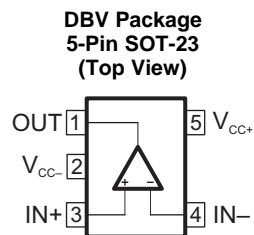

### Pin Functions

NAME	PIN		I/O	DESCRIPTION
	SOIC	SOT-23		
IN-	2	4	I	Negative input
IN+	3	3	I	Positive input
NC	1	—	—	Do not connect
	5			
	8			
OUT	6	1	O	Output
V <sub>CC-</sub>	4	2	—	Negative supply
V <sub>CC+</sub>	7	5	—	Positive supply

## 6 Specifications

### 6.1 Absolute Maximum Ratings

 over operating free-air temperature range (unless otherwise noted)<sup>(1)</sup>

		MIN	MAX	UNIT
Supply voltage, $V_{CC}$	Single supply		32	V
	Dual supplies		±16	
Differential input voltage <sup>(2)</sup> , $V_{ID}$			±32	V
Input voltage range <sup>(3)</sup> , $V_I$		-0.3	32	V
Input current, $I_{IK}$			50	mA
Duration of output short circuit to ground, $t_{short}$			Unlimited	
Operating virtual junction temperature, $T_J$			150	°C
Storage temperature, $T_{stg}$		-65	150	°C

- (1) Stresses beyond those listed under *Absolute Maximum Ratings* may cause permanent damage to the device. These are stress ratings only, and functional operation of the device at these or any other conditions beyond those indicated under *Recommended Operating Conditions* is not implied. Exposure to absolute-maximum-rated conditions for extended periods may affect device reliability.
- (2) Differential voltages are at IN+ with respect to IN-.
- (3) Input voltages are at IN with respect to  $V_{CC-}$ .

### 6.2 ESD Ratings

		VALUE	UNIT
$V_{(ESD)}$ Electrostatic discharge	Human-body model (HBM), per ANSI/ESDA/JEDEC JS-001 <sup>(1)</sup>	±2500	V
	Charged-device model (CDM), per JEDEC specification JESD22-C101 <sup>(2)</sup>	±1500	

- (1) JEDEC document JEP155 states that 500-V HBM allows safe manufacturing with a standard ESD control process.
- (2) JEDEC document JEP157 states that 250-V CDM allows safe manufacturing with a standard ESD control process.

### 6.3 Recommended Operating Conditions

		MIN	MAX	UNIT
$V_{CC}$ Supply voltage	Single supply	3	30	V
	Dual supply	±1.5	±15	
$T_A$ Operating free-air temperature		-40	125	°C

### 6.4 Thermal Information: TS321

THERMAL METRIC <sup>(1)</sup> (2)(3)	TS321		UNIT
	D (SOIC)	DBV (SOT-23)	
	5 PINS	5 PINS	
$R_{\theta JA}$ Junction-to-ambient thermal resistance	97	206	°C/W

- (1) For more information about traditional and new thermal metrics, see the [Semiconductor and IC Package Thermal Metrics](#) application report.
- (2) Maximum power dissipation is a function of  $T_J(\max)$ ,  $q_{JA}$ , and  $T_A$ . The maximum allowable power dissipation at any allowable ambient temperature is  $PD = [T_J(\max) - T_A] / q_{JA}$ . Selecting the maximum of 150°C can effect reliability.
- (3) The package thermal impedance is calculated in accordance with JESD 51-7.

## 6.5 Electrical Characteristics

 $V_{CC+} = 5\text{ V}$ ,  $V_{CC-} = \text{GND}$ ,  $V_O = 1.4\text{ V}$  (unless otherwise noted)

PARAMETER		TEST CONDITIONS		MIN	TYP	MAX	UNIT
$V_{IO}$	Input offset voltage	$R_S = 0$ , $5\text{ V} < V_{CC+} < 30\text{ V}$ $0 < V_{IC} < (V_{CC+} - 1.5\text{ V})$	$T_A = 25^\circ\text{C}$	0.5	4	mV	
			$T_A = \text{Full range}$		5		
$I_{IO}$	Input offset current		$T_A = 25^\circ\text{C}$	2	30	nA	
			$T_A = \text{Full range}$		50		
$I_{IB}$	Input bias current <sup>(1)</sup>		$T_A = 25^\circ\text{C}$	20	150	nA	
			$T_A = \text{Full range}$		200		
$A_{VD}$	Large-signal differential voltage amplification	$V_{CC} = 15\text{ V}$ , $R_L = 2\text{ k}\Omega$ $V_O = 1.4\text{ V to } 11.4\text{ V}$	$T_A = 25^\circ\text{C}$	50	100	V/mV	
			$T_A = \text{Full range}$	25			
$V_{ICR}$	Common-mode input voltage <sup>(2)</sup>	$V_{CC} = 30\text{ V}$	$T_A = 25^\circ\text{C}$	0	$V_{CC+} - 1.5$	V	
			$T_A = \text{Full range}$	0	$V_{CC+} - 2$		
$V_{OH}$	High-level output voltage	$V_{CC} = 30\text{ V}$ $R_L = 2\text{ k}\Omega$	$T_A = 25^\circ\text{C}$	26	27	V	
			$T_A = \text{Full range}$	25.5			
		$V_{CC} = 30\text{ V}$ $R_L = 10\text{ k}\Omega$	$T_A = 25^\circ\text{C}$	27	28		
			$T_A = \text{Full range}$	26.5			
$V_{OL}$	Low-level output voltage	$R_L = 10\text{ k}\Omega$	$T_A = 25^\circ\text{C}$	5	15	mV	
			$T_A = \text{Full range}$		20		
GBP	Gain bandwidth product	$V_{CC} = 30\text{ V}$ , $V_I = 10\text{ mV}$ , $R_L = 2\text{ k}\Omega$ $f = 100\text{ kHz}$ , $C_L = 100\text{ pF}$ $T_A = 25^\circ\text{C}$		0.8		MHz	
SR	Slew rate	$V_{CC} = 15\text{ V}$ , $V_I = 0.5\text{ V to } 3\text{ V}$ , $R_L = 2\text{ k}\Omega$ , $C_L = 100\text{ pF}$ , unity gain, $T_A = 25^\circ\text{C}$		0.4		V/ $\mu\text{s}$	
$\phi_m$	Phase margin	$T_A = 25^\circ\text{C}$		60		°	
CMRR	Common-mode rejection ratio	$R_S \leq 10\text{ k}\Omega$ $T_A = 25^\circ\text{C}$	65	85		dB	
$I_{SOURCE}$	Output source current	$V_{CC} = 15\text{ V}$ , $V_O = 2\text{ V}$ , $V_{ID} = 1\text{ V}$ $T_A = 25^\circ\text{C}$	20	40		mA	
$I_{SINK}$	Output sink current	$V_{CC} = 15\text{ V}$ , $V_{ID} = 1\text{ V}$ $V_O = 2\text{ V}$ $T_A = 25^\circ\text{C}$	10	20		mA	
		$V_{CC} = 15\text{ V}$ , $V_{ID} = 1\text{ V}$ $V_O = 0.2\text{ V}$ $T_A = 25^\circ\text{C}$	12	50		$\mu\text{A}$	
$I_O$	Short-circuit to GND	$V_{CC} = 15\text{ V}$ , $T_A = 25^\circ\text{C}$		40	60	mA	
SVR	Supply-voltage rejection ratio	$V_{CC} = 5\text{ V to } 30\text{ V}$ , $T_A = 25^\circ\text{C}$	65	110		dB	
$I_{CC}$	Total supply current	$V_{CC} = 5\text{ V}$ $T_A = 25^\circ\text{C}$ , no load		500	800	$\mu\text{A}$	
		$V_{CC} = 30\text{ V}$ $T_A = 25^\circ\text{C}$ , no load		600	900		
		$V_{CC} = 5\text{ V}$ $T_A = \text{full range}$ , no load		600	900		
		$V_{CC} = 30\text{ V}$ $T_A = \text{full range}$ , no load			1000		
THD	Total harmonic distortion	$V_{CC} = 30\text{ V}$ , $V_O = 2\text{ V}_{pp}$ , $A_V = 20\text{ dB}$ $R_L = 2\text{ k}$ , $f = 1\text{ kHz}$ , $C_L = 100\text{ pF}$ , $T_A = 25^\circ\text{C}$		0.015%			

- The direction of the input current is out of the device. This current essentially is constant, independent of the state of the output, so no loading change exists on the input lines.
- The input common-mode voltage of either input signal should not be allowed to go negative by more than 0.3 V. The upper end of the common-mode voltage range is  $V_{CC+} - 1.5\text{ V}$ , but either or both inputs can go to 32 V without damage.

**Electrical Characteristics (continued)**
 $V_{CC+} = 5\text{ V}$ ,  $V_{CC-} = \text{GND}$ ,  $V_O = 1.4\text{ V}$  (unless otherwise noted)

PARAMETER		TEST CONDITIONS	MIN	TYP	MAX	UNIT
$e_N$	Equivalent input noise voltage	$V_{CC} = 30\text{ V}$ , $f = 1\text{ kHz}$ , $R_S = 100\ \Omega$ $T_A = 25^\circ\text{C}$		50		

## 6.6 Typical Characteristics

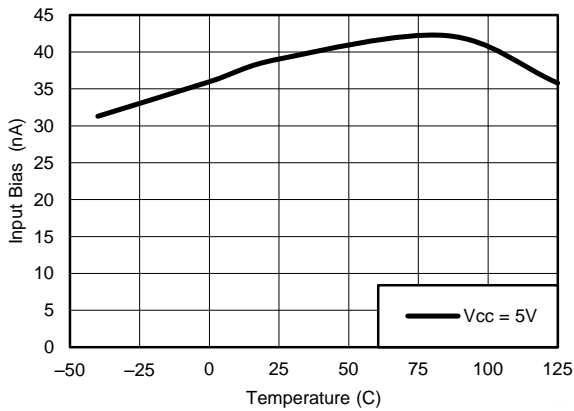

Figure 1. Input Current vs Temperature

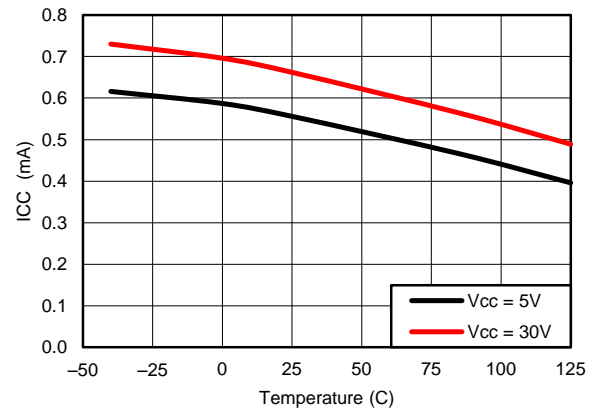

Figure 2. Supply Current vs Temperature

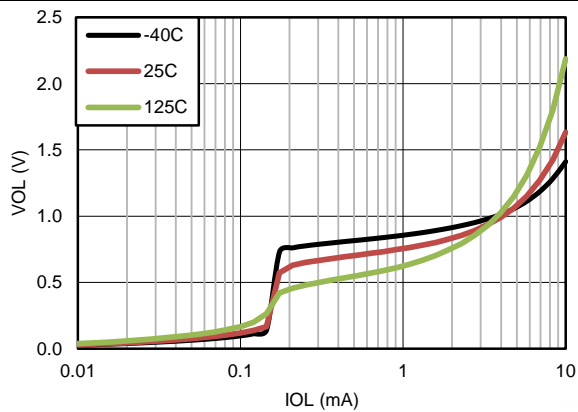

Figure 3. Output Sinking Characteristics

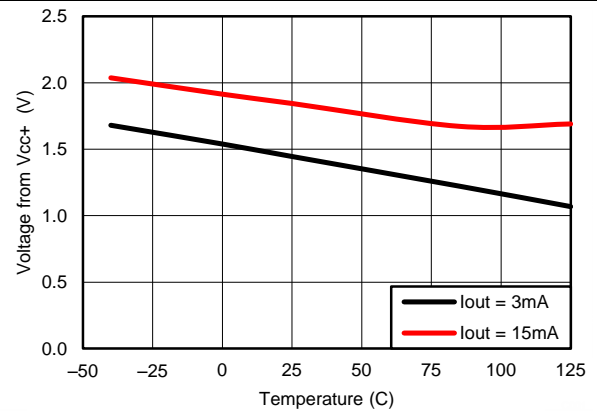

Figure 4. Output Sourcing Characteristics

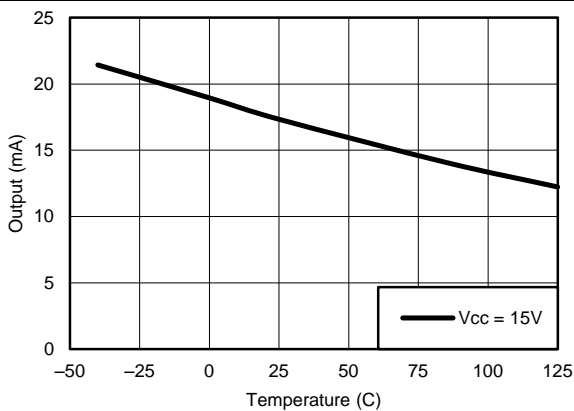

Figure 5. Short-Circuit Current to Supply <sup>(1)</sup>

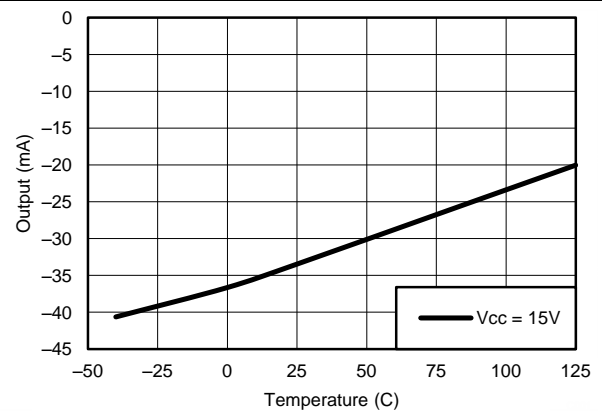

Figure 6. Short-Circuit Current to Ground

(1) Short circuits from outputs to VCC can cause excessive heating and eventual destruction.

## 7 Detailed Description

### 7.1 Overview

The TS321 is a single-channel operational amplifier. The device can handle a single supply between 3 V and 30 V or a dual-supply between  $\pm 1.5$  V and  $\pm 15$  V. Available in the small SOT-23 package, the TS321 is great for saving space in any application.

### 7.2 Functional Block Diagram

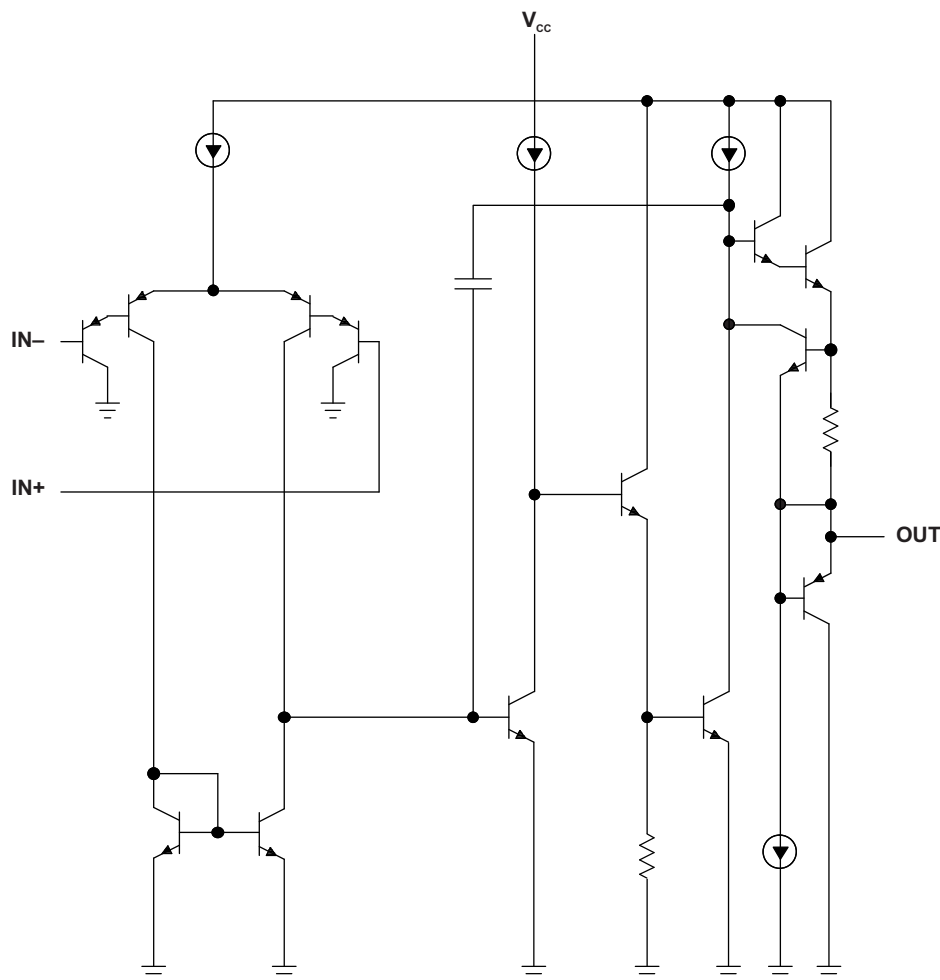

### 7.3 Feature Description

#### 7.3.1 Operating Voltage

The TS321 can be powered from a single supply between 3 V and 30 V or a dual-supply between  $\pm 1.5$  V and  $\pm 15$  V.

#### 7.3.2 Gain Bandwidth Product

Gain bandwidth product is found by multiplying a measured bandwidth of the amplifier by the gain at which that bandwidth was measured. The TS321 has a gain bandwidth of 0.8 MHz.

#### 7.3.3 Slew Rate

The slew rate is the rate at which an operational amplifier can change the output when there is a change on the input. The TS321 has a  $0.4\text{-V}/\mu\text{s}$  slew rate.

## Feature Description (continued)

### 7.3.4 Input Common-Mode Range

The valid common-mode range is from device ground pin to  $V_{CC} - 1.5\text{ V}$  ( $V_{CC} - 2\text{ V}$  across temperature). Inputs may exceed  $V_{CC}$  up to the maximum  $V_{CC}$  without device damage. At least one input must be in the valid input common-mode range for output to be correct phase. If both inputs exceed valid range then output phase is undefined. If either input is less than  $-0.3\text{ V}$  then input current must be limited to  $1\text{ mA}$  and output phase is undefined.

### 7.3.5 Stability With High Capacitive Loads

Operational amplifiers have reduced phase margin when there is a direct capacitance on the output. The stability is affected most when the amplifier is set to unity gain. Small signal response to a step input of  $100\text{ mV}$  reveals the loop stability with a range of capacitors. See [SLVA381](#) to correlate response waveform to phase margin. The responses at  $1\text{ nF}$  or less indicate acceptable phase margin. The responses at  $1\text{ }\mu\text{F}$  and above indicate good phase margin.

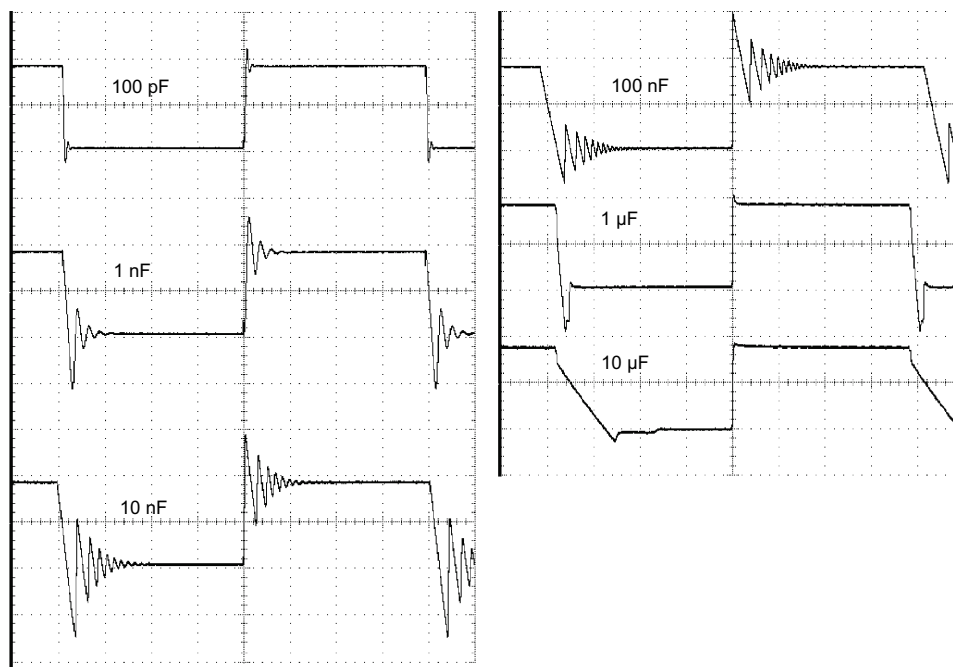

Figure 7. Small-Signal Response

## 7.4 Device Functional Modes

The TS321 is powered on when the supply is connected. This device can operate as a single-supply operational amplifier or dual-supply amplifier depending on the application.

## 8 Application and Implementation

### NOTE

Information in the following applications sections is not part of the TI component specification, and TI does not warrant its accuracy or completeness. TI's customers are responsible for determining suitability of components for their purposes. Customers should validate and test their design implementation to confirm system functionality.

### 8.1 Application Information

The TS321 operational amplifier is useful in a wide range of signal conditioning applications. Inputs can be powered before VCC for flexibility in multiple supply circuits.

### 8.2 Typical Application

A typical application for an operational amplifier is an inverting amplifier. This amplifier takes a positive voltage on the input, and makes the voltage a negative voltage of the same magnitude. In the same manner, the amplifier makes negative voltages positive.

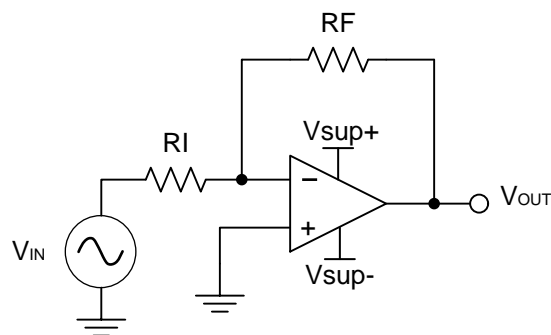

**Figure 8. Typical Application Schematic**

#### 8.2.1 Design Requirements

The supply voltage must be selected such that the supply voltage is larger than the input voltage range and output range. For instance, this application scales a signal of  $\pm 0.5$  V to  $\pm 1.8$  V. Setting the supply at  $\pm 12$  V is sufficient to accommodate this application.

#### 8.2.2 Detailed Design Procedure

Determine the gain required by the inverting amplifier:

$$A_V = \frac{V_{OUT}}{V_{IN}} \quad (1)$$

$$A_V = \frac{1.8}{-0.5} = -3.6 \quad (2)$$

Once the desired gain is determined, select a value for  $R_I$  or  $R_F$ . Selecting a value in the kilohm range is desirable because the amplifier circuit uses currents in the milliamp range. This ensures the part does not draw too much current. This example selects 10 k $\Omega$  for  $R_I$  which means 36 k $\Omega$  is used for  $R_F$ . This is determined by [Equation 3](#).

$$A_V = -\frac{R_F}{R_I} \quad (3)$$

**Typical Application (continued)**

**8.2.3 Application Curve**

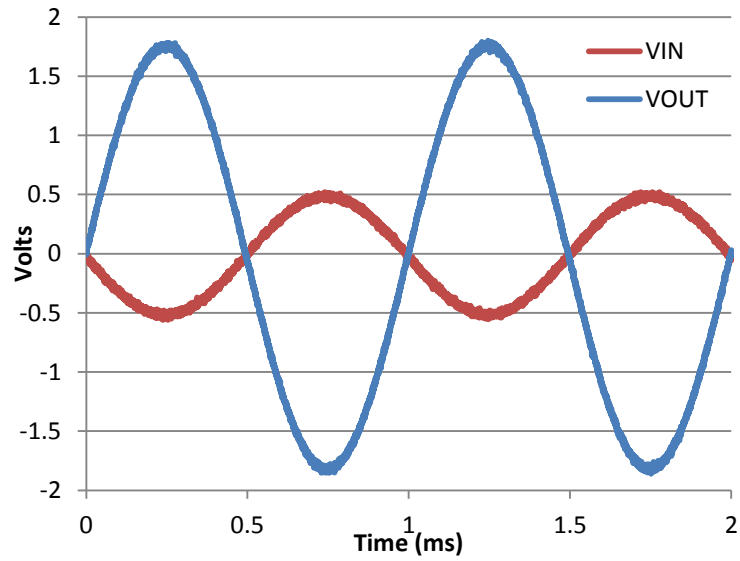

**Figure 9. Input and Output Voltages of the Inverting Amplifier**

## 9 Power Supply Recommendations

The TS321 is specified to operate between 3 V and 30 V or a dual supply between  $\pm 1.5$  V and  $\pm 15$  V.

### CAUTION

Supply voltages larger than 32 V for a single supply, or outside the range of  $\pm 16$  V for a dual supply can permanently damage the device (see the [Absolute Maximum Ratings](#)).

Place 0.1- $\mu$ F bypass capacitors close to the power-supply pins to reduce errors coupling in from noisy or high impedance power supplies. For more detailed information on bypass capacitor placement, see the [Layout](#) section.

## 10 Layout

### 10.1 Layout Guidelines

For best operational performance of the device, use good PCB layout practices, including:

- Noise can propagate into analog circuitry through the power pins of the circuit as a whole, as well as the operational amplifier. Bypass capacitors are used to reduce the coupled noise by providing low impedance power sources local to the analog circuitry.
  - Connect low-ESR, 0.1- $\mu$ F ceramic bypass capacitors between each supply pin and ground, placed as close to the device as possible. A single bypass capacitor from V+ to ground is applicable for single supply applications.
- Separate grounding for analog and digital portions of circuitry is one of the simplest and most-effective methods of noise suppression. One or more layers on multilayer PCBs are usually devoted to ground planes. A ground plane helps distribute heat and reduces EMI noise pickup. Make sure to physically separate digital and analog grounds, paying attention to the flow of the ground current. For more detailed information, see [SLOA089](#).
- To reduce parasitic coupling, run the input traces as far away from the supply or output traces as possible. If it is not possible to keep them separate, it is much better to cross the sensitive trace perpendicular as opposed to in parallel with the noisy trace.
- Place the external components as close to the device as possible. Keeping  $R_F$  and  $R_G$  close to the inverting input minimizes parasitic capacitance, as shown in [Layout Example](#).
- Keep the length of input traces as short as possible. Always remember that the input traces are the most sensitive part of the circuit.
- Consider a driven, low-impedance guard ring around the critical traces. A guard ring can significantly reduce leakage currents from nearby traces that are at different potentials.

### 10.2 Layout Example

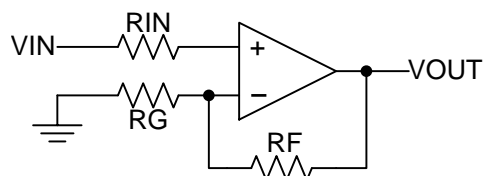

**Figure 10. Operational Amplifier Schematic for Noninverting Configuration**

Layout Example (continued)

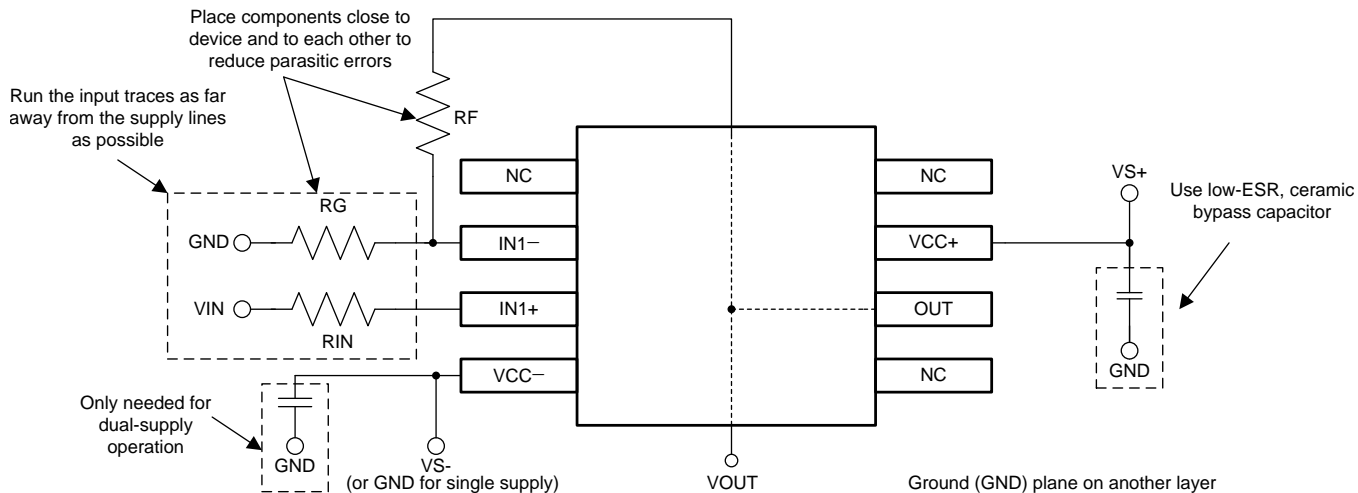

Figure 11. Operational Amplifier Board Layout for Noninverting Configuration

## 11 Device and Documentation Support

### 11.1 Documentation Support

#### 11.1.1 Related Documentation

For more information, see the following:

- [Simplifying Stability Checks](#)
- [Circuit Board Layout Techniques](#)

### 11.2 Trademarks

All trademarks are the property of their respective owners.

### 11.3 Electrostatic Discharge Caution



These devices have limited built-in ESD protection. The leads should be shorted together or the device placed in conductive foam during storage or handling to prevent electrostatic damage to the MOS gates.

### 11.4 Glossary

[SLYZ022](#) — *TI Glossary*.

This glossary lists and explains terms, acronyms, and definitions.

**PACKAGING INFORMATION**

Orderable Device	Status (1)	Package Type	Package Drawing	Pins	Package Qty	Eco Plan (2)	Lead/Ball Finish (6)	MSL Peak Temp (3)	Op Temp (°C)	Device Marking (4/5)	Samples
TS321ID	ACTIVE	SOIC	D	8	75	Green (RoHS & no Sb/Br)	CU NIPDAU	Level-1-260C-UNLIM	-40 to 125	SR321I	<a href="#">Samples</a>
TS321IDBVR	ACTIVE	SOT-23	DBV	5	3000	Green (RoHS & no Sb/Br)	CU NIPDAU   CU SN	Level-1-260C-UNLIM	-40 to 125	(9C1G, 9C1S)	<a href="#">Samples</a>
TS321IDBvre4	ACTIVE	SOT-23	DBV	5	3000	Green (RoHS & no Sb/Br)	CU NIPDAU	Level-1-260C-UNLIM	-40 to 125	9C1G	<a href="#">Samples</a>
TS321IDBVRG4	ACTIVE	SOT-23	DBV	5	3000	Green (RoHS & no Sb/Br)	CU NIPDAU	Level-1-260C-UNLIM	-40 to 125	9C1G	<a href="#">Samples</a>
TS321IDBVT	ACTIVE	SOT-23	DBV	5	250	Green (RoHS & no Sb/Br)	CU NIPDAU   CU SN	Level-1-260C-UNLIM	-40 to 125	(9C1G, 9C1S)	<a href="#">Samples</a>
TS321IDR	ACTIVE	SOIC	D	8	2500	Green (RoHS & no Sb/Br)	CU NIPDAU	Level-1-260C-UNLIM	-40 to 125	SR321I	<a href="#">Samples</a>

(1) The marketing status values are defined as follows:

**ACTIVE:** Product device recommended for new designs.

**LIFEBUY:** TI has announced that the device will be discontinued, and a lifetime-buy period is in effect.

**NRND:** Not recommended for new designs. Device is in production to support existing customers, but TI does not recommend using this part in a new design.

**PREVIEW:** Device has been announced but is not in production. Samples may or may not be available.

**OBSELETE:** TI has discontinued the production of the device.

(2) **RoHS:** TI defines "RoHS" to mean semiconductor products that are compliant with the current EU RoHS requirements for all 10 RoHS substances, including the requirement that RoHS substance do not exceed 0.1% by weight in homogeneous materials. Where designed to be soldered at high temperatures, "RoHS" products are suitable for use in specified lead-free processes. TI may reference these types of products as "Pb-Free".

**RoHS Exempt:** TI defines "RoHS Exempt" to mean products that contain lead but are compliant with EU RoHS pursuant to a specific EU RoHS exemption.

**Green:** TI defines "Green" to mean the content of Chlorine (Cl) and Bromine (Br) based flame retardants meet JS709B low halogen requirements of <=1000ppm threshold. Antimony trioxide based flame retardants must also meet the <=1000ppm threshold requirement.

(3) MSL, Peak Temp. - The Moisture Sensitivity Level rating according to the JEDEC industry standard classifications, and peak solder temperature.

(4) There may be additional marking, which relates to the logo, the lot trace code information, or the environmental category on the device.

(5) Multiple Device Markings will be inside parentheses. Only one Device Marking contained in parentheses and separated by a "~" will appear on a device. If a line is indented then it is a continuation of the previous line and the two combined represent the entire Device Marking for that device.

<sup>(6)</sup> Lead/Ball Finish - Orderable Devices may have multiple material finish options. Finish options are separated by a vertical ruled line. Lead/Ball Finish values may wrap to two lines if the finish value exceeds the maximum column width.

**Important Information and Disclaimer:**The information provided on this page represents TI's knowledge and belief as of the date that it is provided. TI bases its knowledge and belief on information provided by third parties, and makes no representation or warranty as to the accuracy of such information. Efforts are underway to better integrate information from third parties. TI has taken and continues to take reasonable steps to provide representative and accurate information but may not have conducted destructive testing or chemical analysis on incoming materials and chemicals. TI and TI suppliers consider certain information to be proprietary, and thus CAS numbers and other limited information may not be available for release.

In no event shall TI's liability arising out of such information exceed the total purchase price of the TI part(s) at issue in this document sold by TI to Customer on an annual basis.

**OTHER QUALIFIED VERSIONS OF TS321 :**

- Automotive: [TS321-Q1](#)

NOTE: Qualified Version Definitions:

- Automotive - Q100 devices qualified for high-reliability automotive applications targeting zero defects

**TAPE AND REEL INFORMATION**

**QUADRANT ASSIGNMENTS FOR PIN 1 ORIENTATION IN TAPE**

\*All dimensions are nominal

Device	Package Type	Package Drawing	Pins	SPQ	Reel Diameter (mm)	Reel Width W1 (mm)	A0 (mm)	B0 (mm)	K0 (mm)	P1 (mm)	W (mm)	Pin1 Quadrant
TS321IDBVR	SOT-23	DBV	5	3000	180.0	8.4	3.23	3.17	1.37	4.0	8.0	Q3
TS321IDBVR	SOT-23	DBV	5	3000	178.0	9.0	3.23	3.17	1.37	4.0	8.0	Q3
TS321IDBVRG4	SOT-23	DBV	5	3000	178.0	9.0	3.23	3.17	1.37	4.0	8.0	Q3
TS321IDBVT	SOT-23	DBV	5	250	180.0	8.4	3.23	3.17	1.37	4.0	8.0	Q3
TS321IDBVT	SOT-23	DBV	5	250	178.0	9.0	3.23	3.17	1.37	4.0	8.0	Q3
TS321IDR	SOIC	D	8	2500	330.0	12.4	6.4	5.2	2.1	8.0	12.0	Q1

**TAPE AND REEL BOX DIMENSIONS**

\*All dimensions are nominal

Device	Package Type	Package Drawing	Pins	SPQ	Length (mm)	Width (mm)	Height (mm)
TS321IDBVR	SOT-23	DBV	5	3000	202.0	201.0	28.0
TS321IDBVR	SOT-23	DBV	5	3000	180.0	180.0	18.0
TS321IDBVRG4	SOT-23	DBV	5	3000	180.0	180.0	18.0
TS321IDBVT	SOT-23	DBV	5	250	202.0	201.0	28.0
TS321IDBVT	SOT-23	DBV	5	250	180.0	180.0	18.0
TS321IDR	SOIC	D	8	2500	340.5	338.1	20.6



D0008A

# PACKAGE OUTLINE

SOIC - 1.75 mm max height

SMALL OUTLINE INTEGRATED CIRCUIT



NOTES:

1. Linear dimensions are in inches [millimeters]. Dimensions in parenthesis are for reference only. Controlling dimensions are in inches. Dimensioning and tolerancing per ASME Y14.5M.
2. This drawing is subject to change without notice.
3. This dimension does not include mold flash, protrusions, or gate burrs. Mold flash, protrusions, or gate burrs shall not exceed .006 [0.15] per side.
4. This dimension does not include interlead flash.
5. Reference JEDEC registration MS-012, variation AA.

# EXAMPLE BOARD LAYOUT

D0008A

SOIC - 1.75 mm max height

SMALL OUTLINE INTEGRATED CIRCUIT



LAND PATTERN EXAMPLE  
 EXPOSED METAL SHOWN  
 SCALE:8X



SOLDER MASK DETAILS

4214825/C 02/2019

NOTES: (continued)

- 6. Publication IPC-7351 may have alternate designs.
- 7. Solder mask tolerances between and around signal pads can vary based on board fabrication site.

# EXAMPLE STENCIL DESIGN

D0008A

SOIC - 1.75 mm max height

SMALL OUTLINE INTEGRATED CIRCUIT



SOLDER PASTE EXAMPLE  
BASED ON .005 INCH [0.125 MM] THICK STENCIL  
SCALE:8X

4214825/C 02/2019

NOTES: (continued)

8. Laser cutting apertures with trapezoidal walls and rounded corners may offer better paste release. IPC-7525 may have alternate design recommendations.
9. Board assembly site may have different recommendations for stencil design.



# EXAMPLE BOARD LAYOUT

DBV0005A

SOT-23 - 1.45 mm max height

SMALL OUTLINE TRANSISTOR



LAND PATTERN EXAMPLE  
EXPOSED METAL SHOWN  
SCALE:15X

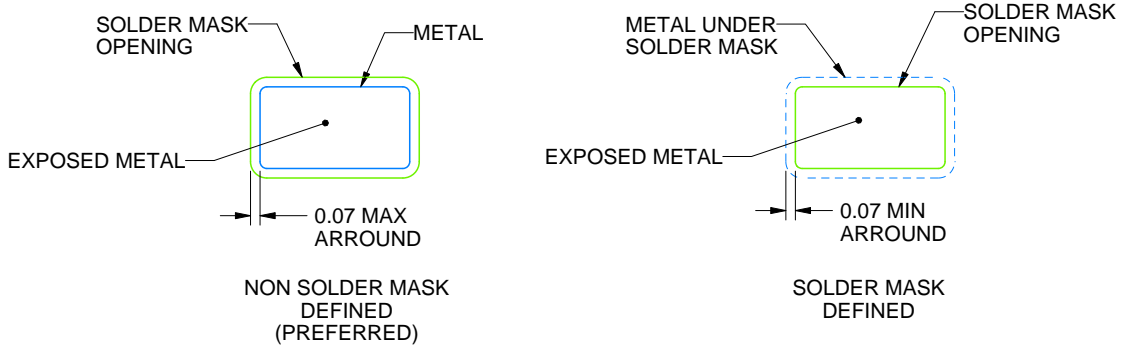

SOLDER MASK DETAILS

4214839/D 11/2018

NOTES: (continued)

- 5. Publication IPC-7351 may have alternate designs.
- 6. Solder mask tolerances between and around signal pads can vary based on board fabrication site.

# EXAMPLE STENCIL DESIGN

DBV0005A

SOT-23 - 1.45 mm max height

SMALL OUTLINE TRANSISTOR



SOLDER PASTE EXAMPLE  
BASED ON 0.125 mm THICK STENCIL  
SCALE:15X

4214839/D 11/2018

NOTES: (continued)

7. Laser cutting apertures with trapezoidal walls and rounded corners may offer better paste release. IPC-7525 may have alternate design recommendations.
8. Board assembly site may have different recommendations for stencil design.

## IMPORTANT NOTICE AND DISCLAIMER

TI PROVIDES TECHNICAL AND RELIABILITY DATA (INCLUDING DATASHEETS), DESIGN RESOURCES (INCLUDING REFERENCE DESIGNS), APPLICATION OR OTHER DESIGN ADVICE, WEB TOOLS, SAFETY INFORMATION, AND OTHER RESOURCES "AS IS" AND WITH ALL FAULTS, AND DISCLAIMS ALL WARRANTIES, EXPRESS AND IMPLIED, INCLUDING WITHOUT LIMITATION ANY IMPLIED WARRANTIES OF MERCHANTABILITY, FITNESS FOR A PARTICULAR PURPOSE OR NON-INFRINGEMENT OF THIRD PARTY INTELLECTUAL PROPERTY RIGHTS.

These resources are intended for skilled developers designing with TI products. You are solely responsible for (1) selecting the appropriate TI products for your application, (2) designing, validating and testing your application, and (3) ensuring your application meets applicable standards, and any other safety, security, or other requirements. These resources are subject to change without notice. TI grants you permission to use these resources only for development of an application that uses the TI products described in the resource. Other reproduction and display of these resources is prohibited. No license is granted to any other TI intellectual property right or to any third party intellectual property right. TI disclaims responsibility for, and you will fully indemnify TI and its representatives against, any claims, damages, costs, losses, and liabilities arising out of your use of these resources.

TI's products are provided subject to TI's Terms of Sale ([www.ti.com/legal/termsofsale.html](http://www.ti.com/legal/termsofsale.html)) or other applicable terms available either on [ti.com](http://ti.com) or provided in conjunction with such TI products. TI's provision of these resources does not expand or otherwise alter TI's applicable warranties or warranty disclaimers for TI products.

Mailing Address: Texas Instruments, Post Office Box 655303, Dallas, Texas 75265  
Copyright © 2019, Texas Instruments Incorporated

## Looking for pricing, stock, or lifecycle information?

Click below to explore more details on WIN SOURCE:

 [View TS321IDBV on WIN SOURCE](#)

 [Texas Instruments](#) Information

## Optimize Your Supply Chain with WIN SOURCE Solutions

-  Global Sourcing Solution
-  Obsolete Management
-  Cost Control Management
-  Shortage Management
-  Alternative Solution
-  Excess Inventory Management