



THE DATASHEET OF TS431AILT



Adjustable shunt voltage reference IC (automotive for SOT23-5)

Datasheet - production data

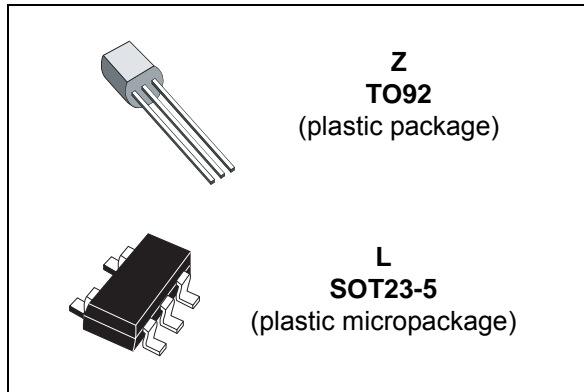
**Description**

The TS431 is a low-voltage, three-terminal, adjustable shunt voltage reference. The output voltage can be set to any value between V_{ref} (1.24 V) and 6 V using two external resistors. The TS431 is able to operate at a lower voltage (1.24 V) and lower cathode current than the widely-used TL431 and TL1431 shunt voltage reference. When driving an optocoupler, the TS431 is particularly suitable for regulating 3.3 V switching power supplies.

Features

- AEC-Q100 qualified (SOT23-5)
- Low voltage operation: 1.24 to 6 V
- 2%, 1% and 0.5% voltage precision
- Wide operating range cathode current: 60 μ A to 30 mA
- Low output impedance: 0.2 Ω
- Typically stable for any capacitive loads
- ESD protection:
- Human body model: 2 kV
 - Machine model: 200 V
- 100 ppm/ $^{\circ}$ C temperature coefficient
- Automotive grade version available

Contents

| | | |
|----------|--|-----------|
| 1 | Pinout | 3 |
| 2 | Absolute maximum ratings and operating conditions | 4 |
| 3 | Electrical characteristics | 5 |
| | Definition of output voltage change over temperature range | 5 |
| 4 | Application information | 9 |
| 5 | Package information | 10 |
| | 5.1 SOT23-5 package information | 11 |
| | 5.2 TO92 (tape ammopack and tape and reel) package information | 12 |
| | 5.3 TO92 (bulk) package information | 13 |
| 6 | Ordering information | 14 |
| 7 | Revision history | 15 |

1 Pinout

Figure 1. Pinout Z TO92 (plastic package)

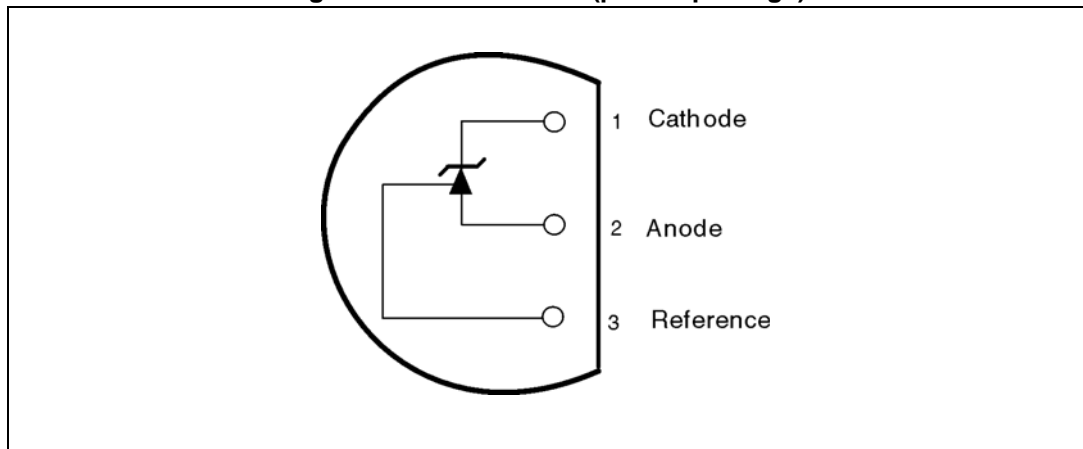
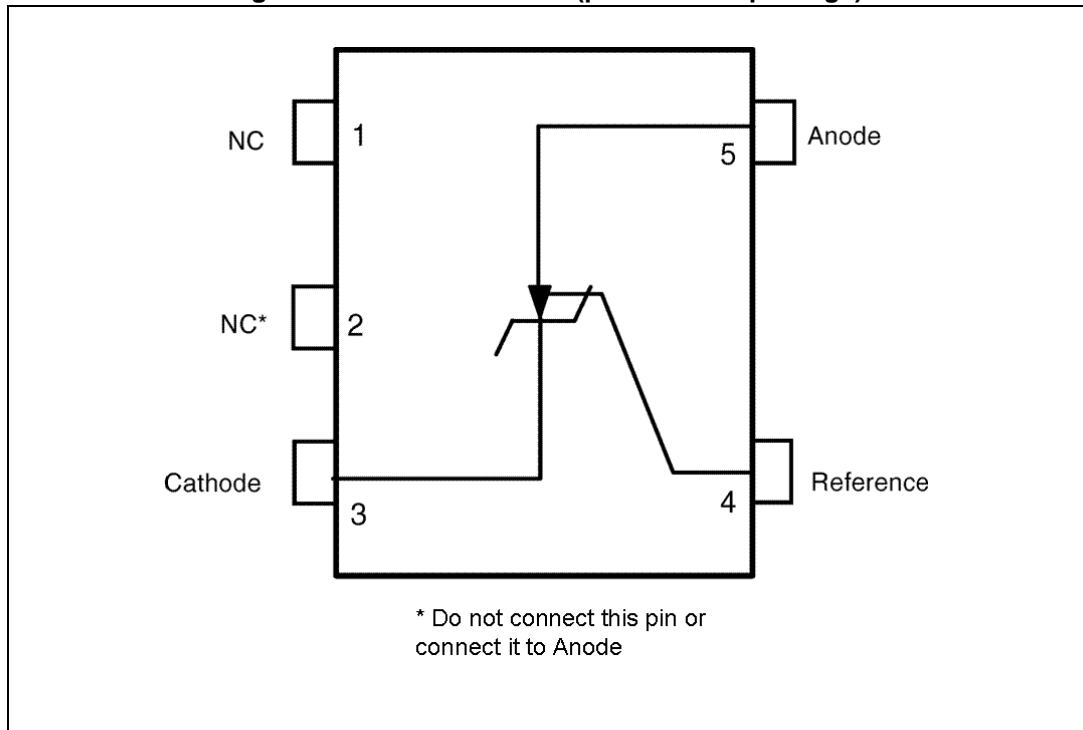

Figure 2. Pinout L SOT23-5 (plastic micropackage)



2 Absolute maximum ratings and operating conditions

Table 1. Absolute maximum ratings

| Symbol | Parameter | Value | Unit |
|-----------|--|-------------|------|
| V_{KA} | Cathode to anode voltage | 10 | V |
| I_k | Continuous cathode current range | -20 to +40 | mA |
| I_{ref} | Reference input current range | -0.05 to +3 | mA |
| P_d | Power dissipation TO92 package SOT23-5 package | 625 500 | mW |
| T_{stg} | Storage temperature range | -65 to +150 | °C |

Table 2. Operating conditions

| Symbol | Parameter | Value | Unit |
|------------|--------------------------------------|-------------|------|
| V_{KA} | Cathode to anode voltage | 1.24 to 6 | V |
| I_k | Cathode current ⁽¹⁾ | 0.06 to 30 | mA |
| T_{oper} | Operating free air temperature range | -40 to +125 | °C |

1. Please refer to [Section 4: Application information](#) for more details.

Table 3. Thermal data

| Symbol | Parameter | TO-92 | SOT23-5L | Unit |
|------------|--|-------|----------|------|
| R_{thJC} | Thermal resistance junction to case | 57 | 136 | °C/W |
| R_{thJA} | Thermal resistance junction to ambient | 200 | 250 | °C/W |

3 Electrical characteristics

Table 4. $T_{amb} = 25\text{ °C}$ (unless otherwise specified)

| Symbol | Parameter | Test conditions | Min. | Typ. | Max. | Unit |
|---|---|--|-------------------------|-------------------------|-------------------------|---------------|
| V_{ref} | Output voltage $V_{KA} = V_{ref}$ at $I_k = 100\text{ }\mu\text{A}$ | TS431 TS431A TS431B | 1.215 1.228 1.234 | 1.240 1.240 1.240 | 1.265 1.252 1.246 | V |
| ΔV_{ref} | Output voltage change ^{(1) (2)} $I_k = 100\text{ }\mu\text{A}$, $V_{KA} = V_{ref}$ | $0 < T_{amb} < +70\text{ °C}$ $-40 < T_{amb} < +85\text{ °C}$ $-40 < T_{amb} < +105\text{ °C}$ $-40 < T_{amb} < +125\text{ °C}$ | - - - - | - - - - | 9 16 18 21 | mV |
| $\left \frac{\Delta V_{ref}}{\Delta V_{KA}} \right $ | Ratio of change in reference input voltage to change in cathode to anode voltage | $I_k = 10\text{ mA}$ $V_{KA} = 6\text{ V to } V_{ref}$ | - | 1.8 | 2.7 | mV/V |
| I_{ref} | Reference input current | $I_k = 10\text{ mA}$ | - | 70 | 160 | nA |
| ΔI_{ref} | Reference input current deviation over temperature range | $I_k = 10\text{ mA}$, $R_1 = 10\text{ k}\Omega$, $R_2 = \infty$ $-40 < T_{amb} < +85\text{ °C}$ $-40 < T_{amb} < +125\text{ °C}$ | - - | 70 90 | 160 240 | nA |
| I_{min} | Minimum cathode current for regulation | $V_{KA} = V_{ref}$ | - | 40 | 60 | μA |
| I_{off} | Off-state cathode current | $V_{KA} = 6\text{ V}$, $V_{ref} = 0$ | - | 0.001 | 0.1 | μA |
| R_{KA} | Static impedance | $V_{KA} = V_{ref}$, $I_k = 0.1\text{ to }15\text{ mA}$ | - | 0.2 | 0.4 | Ω |

- Limits are 100% production tested at 25 °C. Behavior at the temperature range limits is guaranteed through correlation and by design.
- See definition below.

Definition of output voltage change over temperature range

ΔV_{ref} is defined as the difference between the maximum and minimum values obtained over the full temperature range.

$$\Delta V_{ref} = V_{ref\ max} - V_{ref\ min}$$

Figure 3. Output voltage change over temperature range

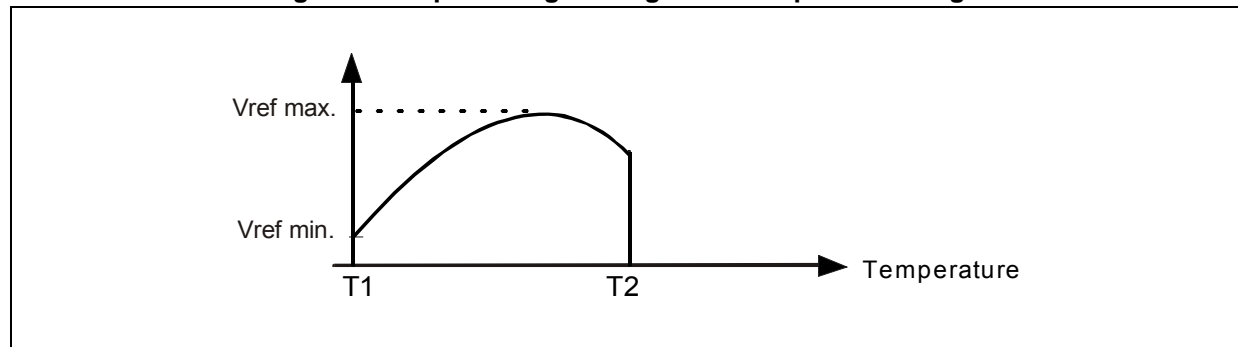

Figure 4. Reference voltage vs. temperature

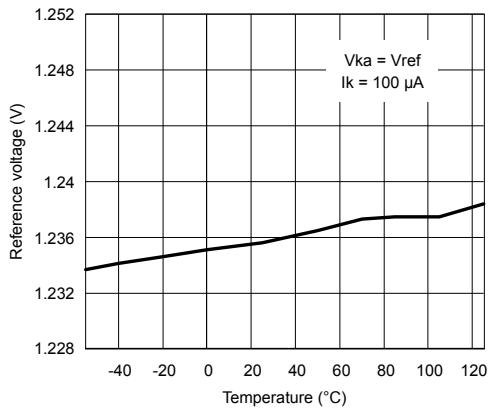

Figure 5. Test circuit for $V_{KA} = V_{ref}$

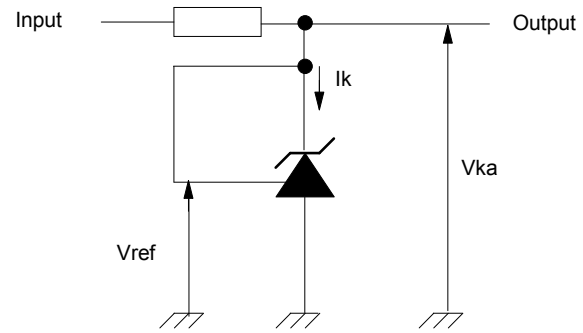

Figure 6. Cathode voltage vs. cathode current

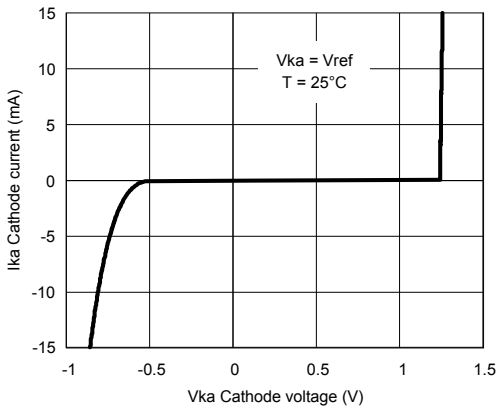

Figure 7. Cathode voltage vs. cathode current

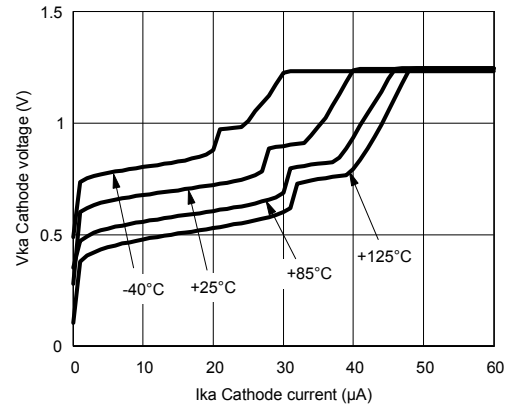

Figure 8. Reference input current vs. temperature

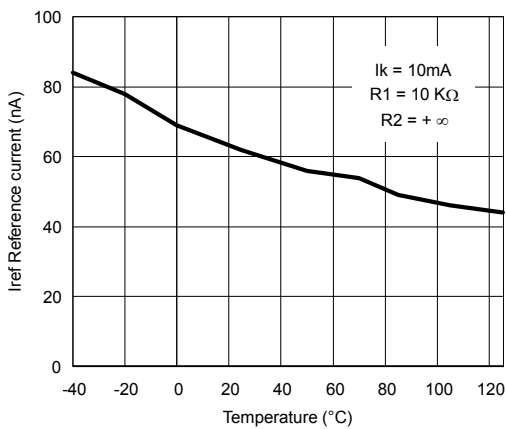

Figure 9. Static impedance vs. temperature

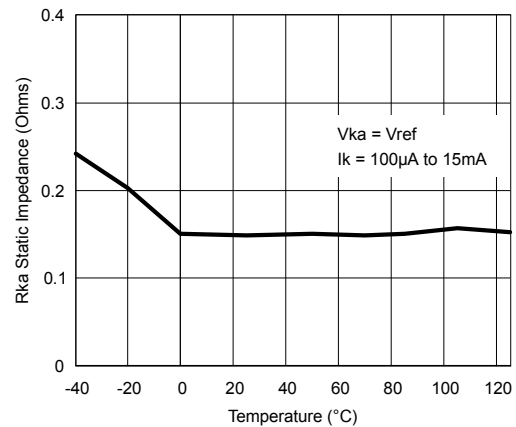

Figure 10. Off-state current vs. temperature

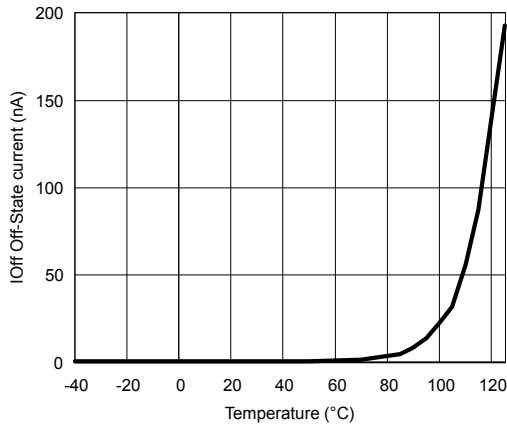

Figure 11. Test circuit for off-state current measurement

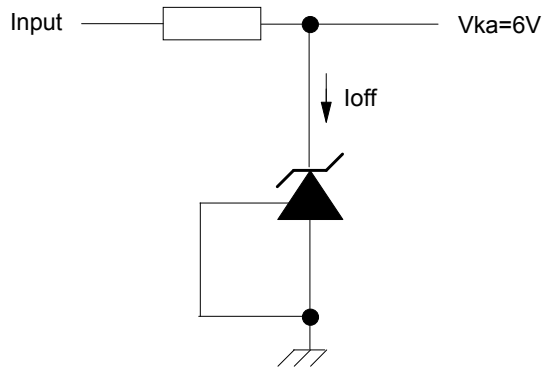

Figure 12. Ratio of change in reference input voltage to change in V_{KA} voltage vs. temperature

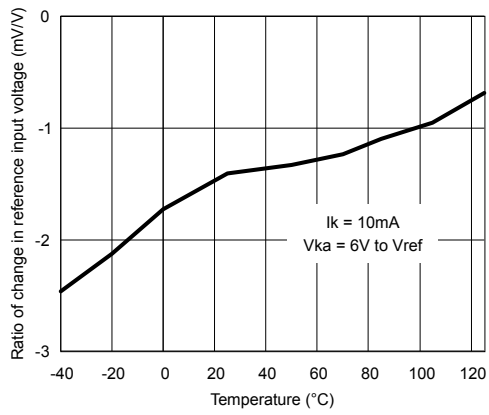

Figure 13. Test circuit for V_{KA} > V_{ref}

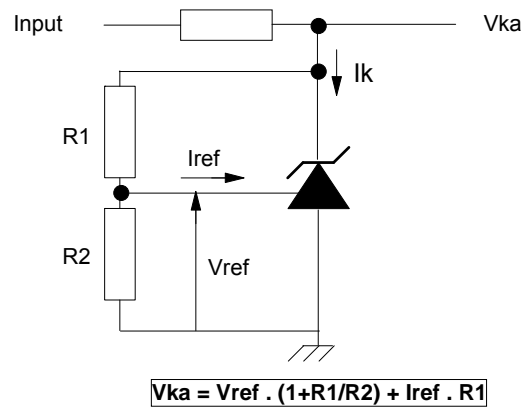

Figure 14. Phase and gain vs. frequency

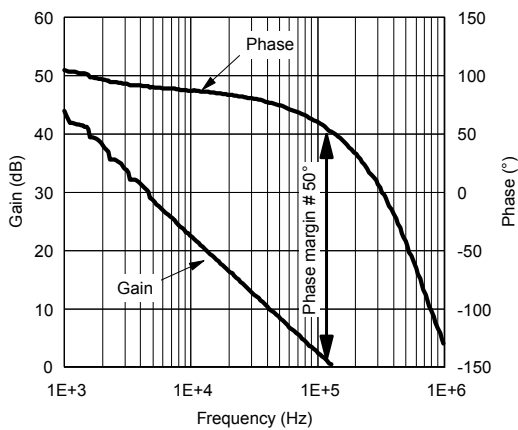

Figure 15. Test circuit for phase and gain measurement

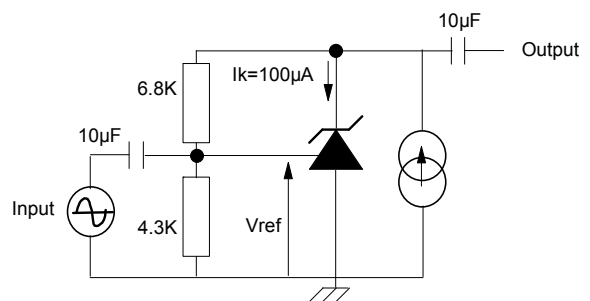

Figure 16. Pulse response at $I_k = 100 \mu A$

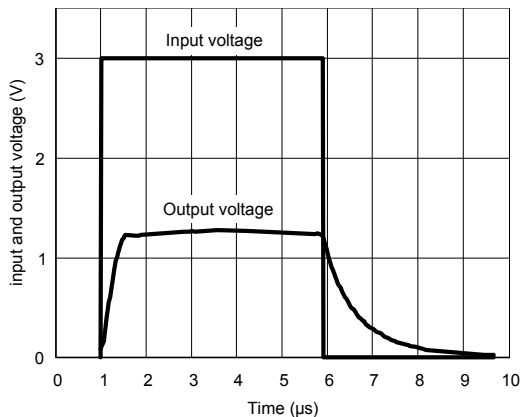

Figure 17. Test circuit for pulse response at $I_k = 100 \mu A$

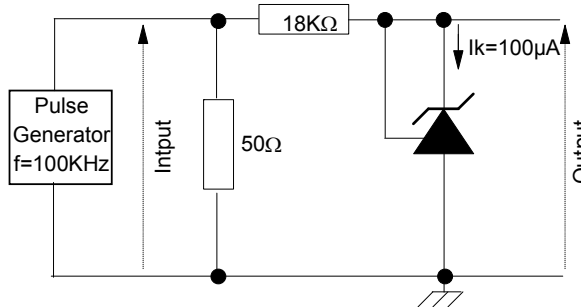

Figure 18. Pulse response at $I_k = 1 mA$

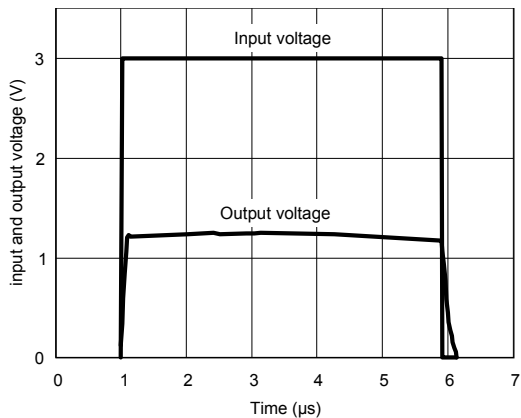

Figure 19. Test circuit for pulse response at $I_k = 1 mA$

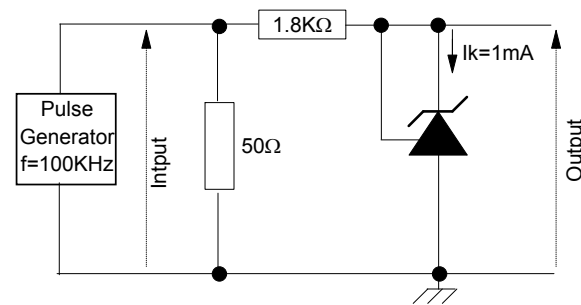
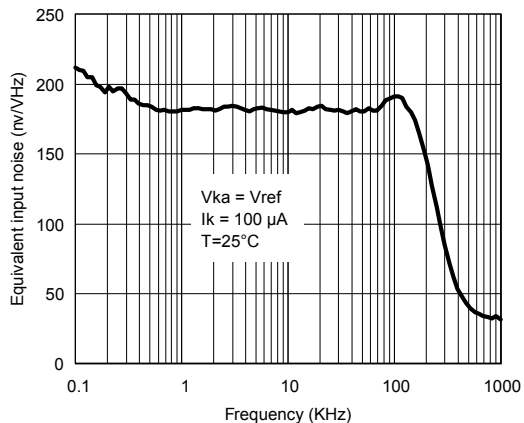

Figure 20. Equivalent input noise vs. frequency



4 Application information

The TS431 is a general-purpose low-power adjustable shunt voltage reference, capable of operating with a cathode current as low as 60 μA and up to 30 mA.

The main static parameters of the TS431 voltage reference are specified in [Table 4 on page 5](#).

Since the TS431 is designed for general-purpose applications with a broad range of cathode currents, voltages and loads, when designing with the device in applications requiring fast dynamic response (turn-on/off and/or pulsed load conditions) it should be considered that upon application of power, the time required for the V_{KA} voltage to reach its final value within a specified error range depends on several factors, among which the temperature, cathode current and capacitive load inrush current are the most influential. The dynamic response of the device to fast turn-on/off, load and temperature changes is optimized when the cathode current is not in the lower end of the operating range ($I_K > 500 \mu\text{A}$).

5 Package information

In order to meet environmental requirements, ST offers these devices in different grades of ECOPACK® packages, depending on their level of environmental compliance. ECOPACK® specifications, grade definitions and product status are available at: www.st.com. ECOPACK® is an ST trademark.

5.1 SOT23-5 package information

Figure 21. SOT23-5 package outline

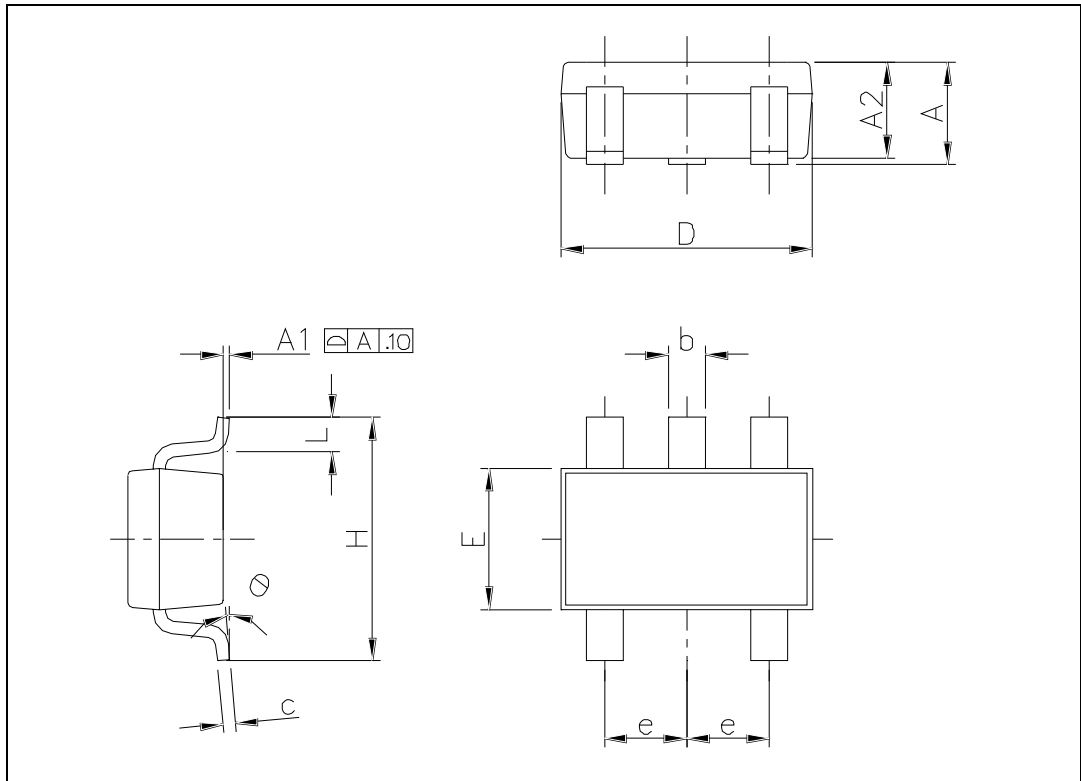

Table 5. SOT23-5 package mechanical data

| Symbol | Dimensions | | | | | |
|--------|-------------|------|------|--------|-------|-------|
| | Millimeters | | | Inches | | |
| | Min. | Typ. | Max. | Min. | Typ. | Max. |
| A | 0.90 | - | 1.45 | 0.035 | - | 0.057 |
| A1 | 0.00 | - | 0.15 | 0.00 | - | 0.006 |
| A2 | 0.90 | - | 1.30 | 0.035 | - | 0.051 |
| b | 0.35 | - | 0.50 | 0.014 | - | 0.02 |
| C | 0.09 | - | 0.20 | 0.003 | - | 0.008 |
| D | 2.80 | - | 3.00 | 0.110 | - | 0.118 |
| H | 2.60 | - | 3.00 | 0.102 | - | 0.118 |
| E | 1.50 | - | 1.75 | 0.059 | - | 0.069 |
| e | - | 0.95 | - | - | 0.037 | - |
| e1 | - | 1.9 | - | - | 0.075 | - |
| L | 0.35 | - | 0.55 | 0.014 | - | 0.022 |

5.2 TO92 (tape ammpack and tape and reel) package information

Figure 22. TO92 (tape ammpack and tape and reel) package outline

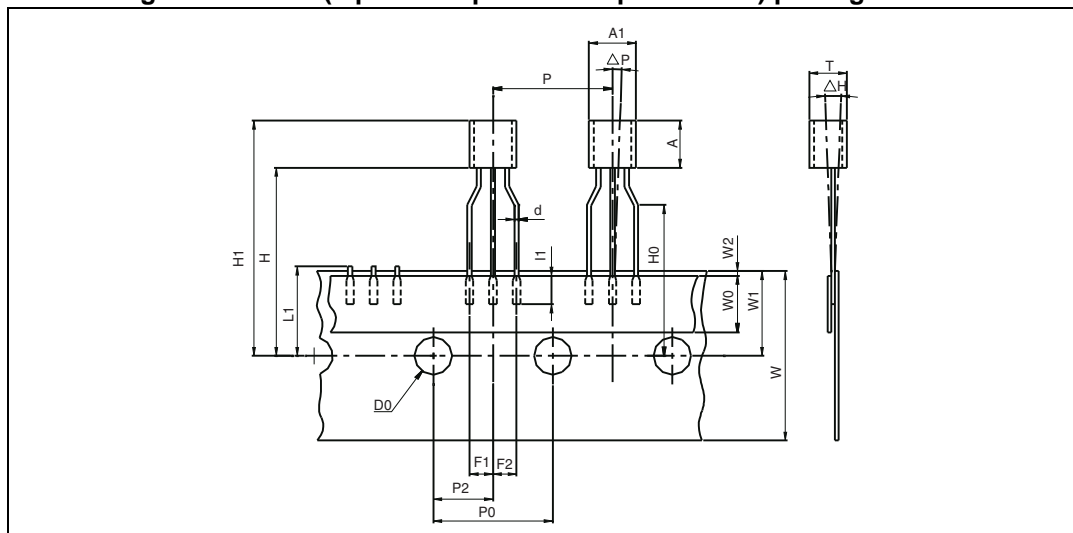

Table 6. TO92 (tape ammpack and tape and reel) package mechanical data

| Symbol | Dimensions (millimeters) | | | Dimensions (Inches) | | |
|--------|--------------------------|------|------|---------------------|-------|-------|
| | Min. | Typ. | Max. | Min. | Typ. | Max. |
| AL | - | - | 5.0 | - | - | 0.197 |
| A | - | - | 5.0 | - | - | 0.197 |
| T | - | - | 4.0 | - | - | 0.157 |
| d | - | 0.45 | - | - | 0.018 | - |
| l1 | 2.5 | - | - | 0.098 | - | - |
| P | 11.7 | 12.7 | 13.7 | 0.461 | 0.500 | 0.539 |
| PO | 12.4 | 12.7 | 13 | 0.488 | 0.500 | 0.512 |
| P2 | 5.95 | 6.35 | 6.75 | 0.234 | 0.250 | 0.266 |
| F1/F2 | 2.4 | 2.5 | 2.8 | 0.094 | 0.098 | 0.110 |
| Δh | -1 | 0 | 1 | -0.039 | 0 | 0.039 |
| ΔP | -1 | 0 | 1 | -0.039 | 0 | 0.039 |
| W | 17.5 | 18.0 | 19.0 | 0.689 | 0.709 | 0.748 |
| W0 | 5.7 | 6 | 6.3 | 0.224 | 0.236 | 0.248 |
| W1 | 8.5 | 9 | 9.75 | 0.335 | 0.354 | 0.384 |
| W2 | - | - | 0.5 | - | - | 0.020 |
| H | - | - | 20 | - | - | 0.787 |
| H0 | 15.5 | 16 | 16.5 | 0.610 | 0.630 | 0.650 |
| H1 | - | - | 25 | - | - | 0.984 |
| DO | 3.8 | 4.0 | 4.2 | 0.150 | 0.157 | 0.165 |
| L1 | - | - | 11 | - | - | 0.433 |

5.3 TO92 (bulk) package information

Figure 23. TO92 (bulk) package outline

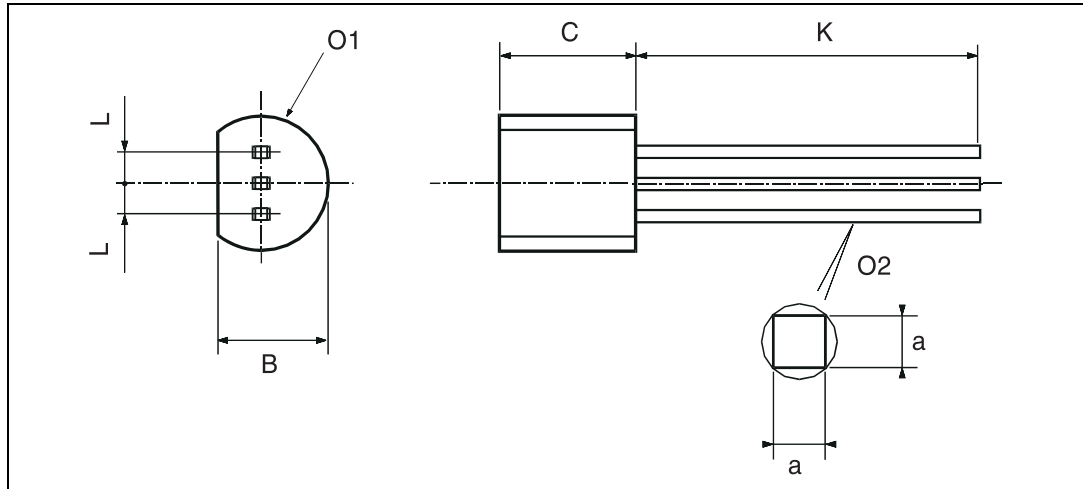

Table 7. TO92 (bulk) package mechanical data

| Symbol | Dimensions | | | | | |
|--------|-------------|------|-------|--------|--------|--------|
| | Millimeters | | | Inches | | |
| | Min. | Typ. | Max. | Min. | Typ. | Max. |
| L | - | 1.27 | - | - | 0.05 | - |
| B | 3.2 | 3.7 | 4.2 | 0.126 | 0.1457 | 0.1654 |
| O1 | 4.45 | 5.00 | 5.2 | 0.1752 | 0.1969 | 0.2047 |
| C | 4.58 | 5.03 | 5.33 | 0.1803 | 0.198 | 0.2098 |
| K | 12.7 | - | - | 0.5 | - | - |
| O2 | 0.407 | 0.5 | 0.508 | 0.016 | 0.0197 | 0.02 |
| a | 0.35 | - | - | 0.0138 | - | - |

6 Ordering information

Table 8. Order codes

| Order codes | Precision | Temp. range | Packages | Packing | Marking |
|---------------------------|-----------|------------------|-------------------------------------|--|---------|
| TS431ILT | 2% | -40 °C, + 125 °C | SOT23-5 | Tape and reel | L272 |
| TS431AILT | 1% | | | | L271 |
| TS431BILT | 0.5% | | | | L270 |
| TS431IYLT ⁽¹⁾ | 2% | | SOT23-5 (automotive grade level) | | L274 |
| TS431AIYLT ⁽¹⁾ | 1% | | | | L276 |
| TS431BIYLT ⁽¹⁾ | 0.5% | | | | L273 |
| TS431IZ/IZT/IZ-AP | 2% | | TO92 | Bulk (Z), tape and reel (ZT) or ammpack (AP) | TS431I |
| TS431AIZ/AIZT/AIZ-AP | 1% | | | | TS431AI |
| TS431BIZ/BIZT/BIZ-AP | 0.5% | | | | TS431BI |

1. Qualification and characterization according to AEC-Q100 and AEC-Q003 or equivalent, advanced screening according to AEC-Q001 and AEC-Q002 or equivalent.

7 Revision history

Table 9. Document revision history

| Date | Revision | Changes |
|-------------|----------|---|
| 1-Sep-2003 | 1 | Initial release. |
| 1-Oct-2005 | 2 | PPAP references inserted in the datasheet. See the order codes table. Minor changes to formatting and grammar. |
| 2-Jan-2006 | 3 | TS431AIYLT PPAP reference inserted. See the order codes table. |
| 22-Sep-2006 | 4 | Included footnote on automotive grade qualification to order codes table. Updated package information (changed mils to inches). |
| 25-Apr-2007 | 5 | Resized graphics on cover page. Moved definition of output voltage change from <i>Table 3</i> footnote to separate section below table. Corrected errors in SOT23-5 package mechanical data. Removed erroneous drawing for TO92 tape & reel package. |
| 30-Aug-2007 | 6 | Updated drawing for TO92 bulk package. Modified footnote related to automotive grade qualification in <i>Table 5: Order codes</i> , and re-ordered order codes. |
| 27-Aug-2010 | 7 | Modified note for package SOT23-5 on page 1. |
| 15-Nov-2012 | 8 | Modified note 1 <i>Table 5 on page 12</i> . |
| 17-Dec-2012 | 9 | Added note 1 <i>Table 2 on page 2</i> and <i>Section 3 on page 7</i> . |
| 12-Mar-2013 | 10 | Added features Automotive grade version available in cover page. |
| 30-Nov-2017 | 11 | Added automotive qualification for SOT23-5 in the whole document. Updated main title on page 1. Added Section 1: Pinout on page 3. Updated Table 1 on page 4 (removed note 1). Added Table 3 on page 4. Minor modifications throughout document. |
| 27-Jun-2018 | 12 | Added precision value in <i>Table 8: Order codes</i> . |

IMPORTANT NOTICE – PLEASE READ CAREFULLY

STMicroelectronics NV and its subsidiaries (“ST”) reserve the right to make changes, corrections, enhancements, modifications, and improvements to ST products and/or to this document at any time without notice. Purchasers should obtain the latest relevant information on ST products before placing orders. ST products are sold pursuant to ST’s terms and conditions of sale in place at the time of order acknowledgement.

Purchasers are solely responsible for the choice, selection, and use of ST products and ST assumes no liability for application assistance or the design of Purchasers’ products.

No license, express or implied, to any intellectual property right is granted by ST herein.

Resale of ST products with provisions different from the information set forth herein shall void any warranty granted by ST for such product.



ST and the ST logo are trademarks of ST. All other product or service names are the property of their respective owners.

Information in this document supersedes and replaces information previously supplied in any prior versions of this document.

© 2018 STMicroelectronics – All rights reserved

Looking for pricing, stock, or lifecycle information?

Click below to explore more details on WIN SOURCE:

-  [View TS431AALT on WIN SOURCE](#)
-  [STMicroelectronics Information](#)

Optimize Your Supply Chain with WIN SOURCE Solutions

-  Global Sourcing Solution
-  Obsolete Management
-  Cost Control Management
-  Shortage Management
-  Alternative Solution
-  Excess Inventory Management