



# THE DATASHEET OF TS432AILT



## 1.24 V adjustable shunt voltage reference

### Features

- 1.24 V typical output voltage
- Ultra low operating current: 60  $\mu$ A maximum at 25° C
- High precision at 25° C:
  - +/- 1%
  - +/- 0.5%
- High stability when used with capacitive loads
- Industrial temperature range: -40° C to +85° C
- 100 ppm/°C temperature coefficient

### Applications

- Computers
- Instrumentation
- Battery chargers
- Switch mode power supply
- Battery operated equipments

### Description

The TS432 is an adjustable low power shunt voltage reference providing an output voltage from 1.24 V to 10 V over the industrial temperature range (-40° C to +85° C). Available in SOT23-3 surface mount package, it can be designed in applications where space saving is critical.

The low operating current is also a key advantage for power restricted designs. In addition, the TS432 is very stable and can be used in a broad range of application conditions.

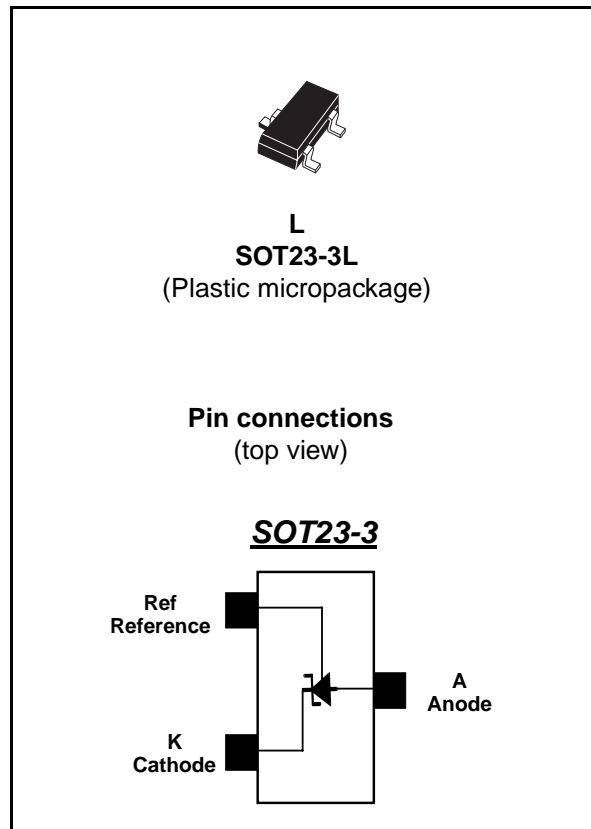

# 1 Absolute maximum ratings and operating conditions

**Table 1. Absolute maximum ratings (AMR)**

Symbol	Parameter	Value	Unit
$V_K$	Cathode voltage	12	V
$I_K$	Cathode current	-10 to +20	mA
$I_{ref}$	Reference input current	-0.05 to +3	mA
$P_d$	Power dissipation <sup>(1)</sup> SOT23-3	340	mW
$R_{thja}$	Thermal resistance junction to ambient for SOT23-3	360	°C/W
$T_{lead}$	Lead temperature (soldering 10 seconds)	250	°C
$T_{stg}$	Storage temperature	-65 to +150	°C
$T_j$	Junction temperature	150	°C
ESD	HBM: human body model	1.5	kV
	MM: machine model	150	V

1.  $P_d$  is calculated with  $T_{amb} = 25^\circ\text{C}$ ,  $T_j = 150^\circ\text{C}$  and  $R_{thja} = 360^\circ\text{C/W}$ .

**Table 2. Operating conditions**

Symbol	Parameter	Value	Unit
$V_K$	Cathode voltage	1.24 to 10	V
$I_K$	Cathode current	60 $\mu$ to 12m	A
$T_{amb}$	Ambient temperature	-40 to +85	°C

## 2 Electrical characteristics

Table 3.  $T_{amb} = 25^{\circ}\text{C}$  (unless otherwise specified)

Symbol	Parameter	Test conditions	Min.	Typ.	Max.	Unit
$V_{ref}$	Reference voltage	$I_K = 100\mu\text{A}$ , $V_K = V_{REF}$		1.24		V
		TS432 (1%)	1.228		1.252	
		TS432A (0.5%)	1.234		1.246	
$\Delta V_{ref}$	Reference voltage tolerance over temperature	$I_K = 100\mu\text{A}$ , $V_K = V_{REF}$		7	16	mV
$I_{Kmin}$	Minimum operating current	$T_{amb} = 25^{\circ}\text{C}$		40	60	$\mu\text{A}$
		$-40^{\circ}\text{C} < T_{amb} < +85^{\circ}\text{C}$			65	
$\Delta V_{ref}$	Reverse breakdown voltage change with operating current range	$I_{Kmin} < I_K < 1\text{mA}$		0.7	1.5	mV
		$-40^{\circ}\text{C} < T_{amb} < +85^{\circ}\text{C}$			2	
		$1\text{mA} < I_K < 12\text{mA}$		2	4	
		$-40^{\circ}\text{C} < T_{amb} < +85^{\circ}\text{C}$			6	
$\Delta V_{ref}/\Delta V_K$	Reference voltage change with output voltage change	$I_K = 10\text{mA}$ , $V_K = 10\text{V}$ to $V_{REF}$		1.8	2.5	mV/V
		$-40^{\circ}\text{C} < T_{amb} < +85^{\circ}\text{C}$			3	
$I_{ref}$	Reference input current	$I_K = 10\text{mA}$ , $R_1 = 10\text{k}\Omega$ , $R_2 = +\infty$		50	100	nA
		$-40^{\circ}\text{C} < T_{amb} < +85^{\circ}\text{C}$			200	
$I_{OFF}$	Off-state cathode current	$V_{REF} = 0$ , $V_K = 10\text{V}$		1	100	nA
		$-40^{\circ}\text{C} < T_{amb} < +85^{\circ}\text{C}$			150	
$R_{KA}$	Static impedance	$\Delta I_K = 100\mu\text{A}$ to $12\text{mA}$		0.25	0.5	W
$K_{VH}$	Long term stability	$I_K = 100\mu\text{A}$ , $t = 1000\text{hrs}$		120		ppm
$E_N$	Wide band noise	$I_K = 100\mu\text{A}$ $100\text{Hz} < F < 10\text{kHz}$		200		nV/ $\sqrt{\text{Hz}}$

Note: Limits are 100% production tested at  $25^{\circ}\text{C}$ . Behavior over the temperature range is guaranteed through correlation and by design.

Figure 1. Reference voltage vs temperature

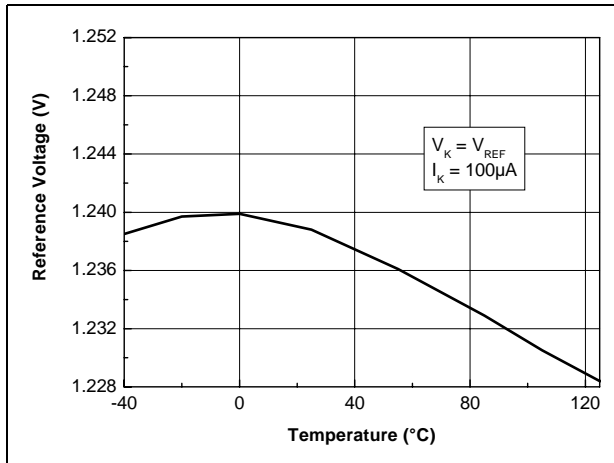

Figure 2. Test circuit for  $V_K = V_{ref}$

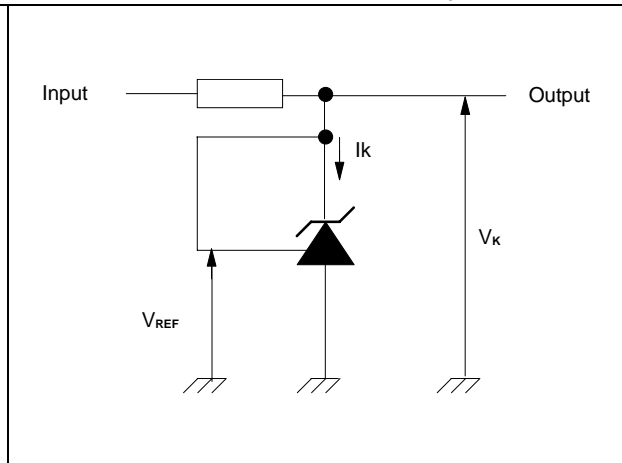

Figure 3. Cathode voltage vs cathode current

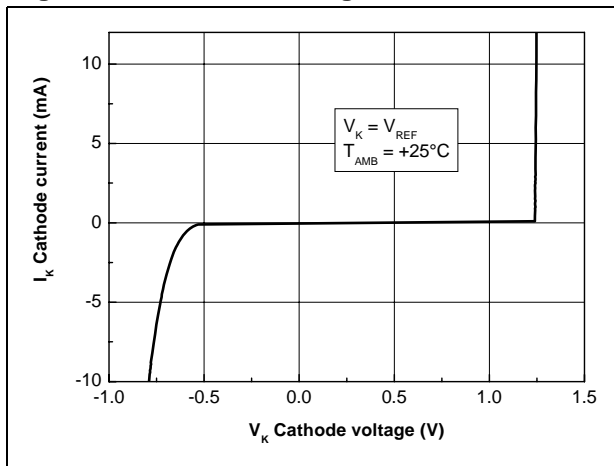

Figure 4. Cathode voltage vs cathode current

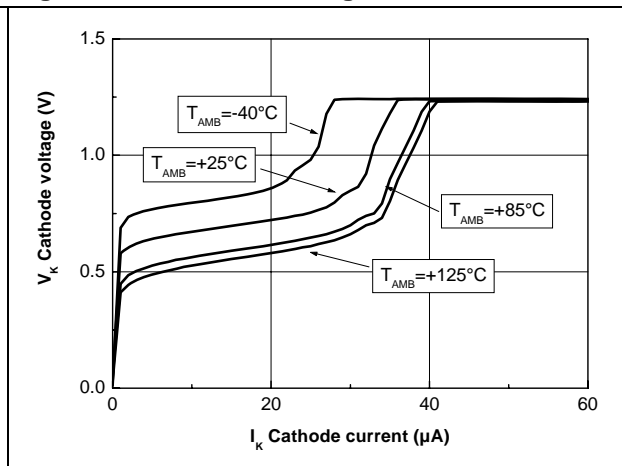

Figure 5. Reference input current vs temperature

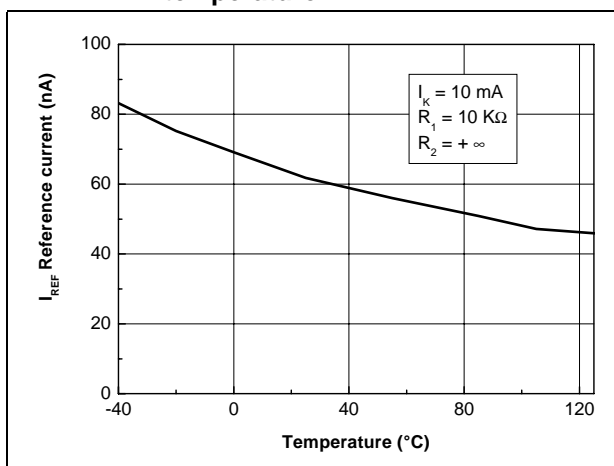

Figure 6. Static impedance vs temperature

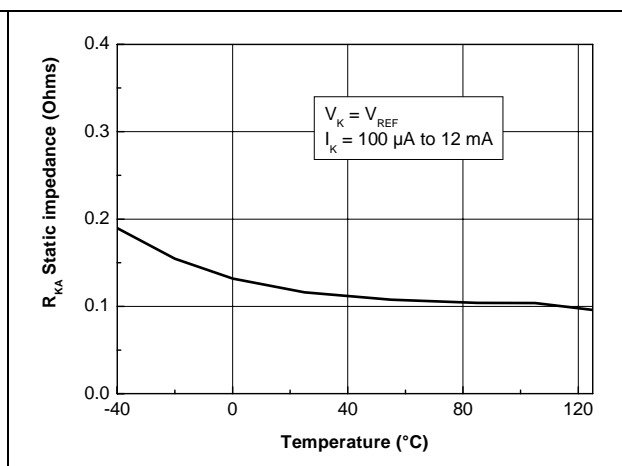

Figure 7. Off-state current vs temperature

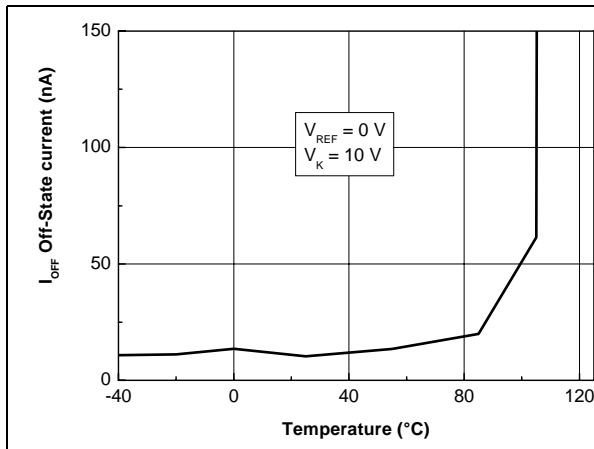

Figure 8. Test circuit for off-state current measurement

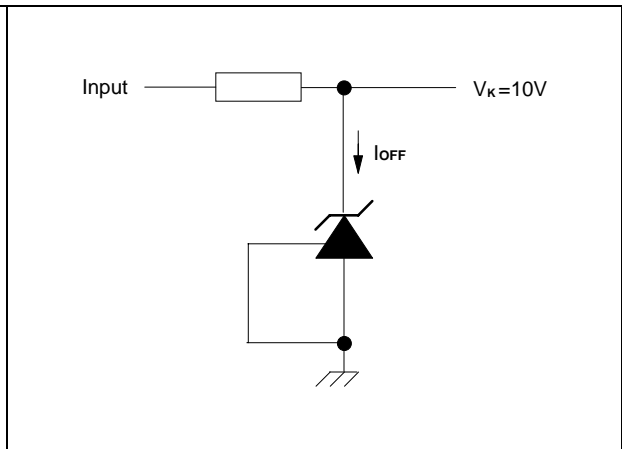

Figure 9. Ratio of change in reference input voltage to change in  $V_K$  voltage vs temperature

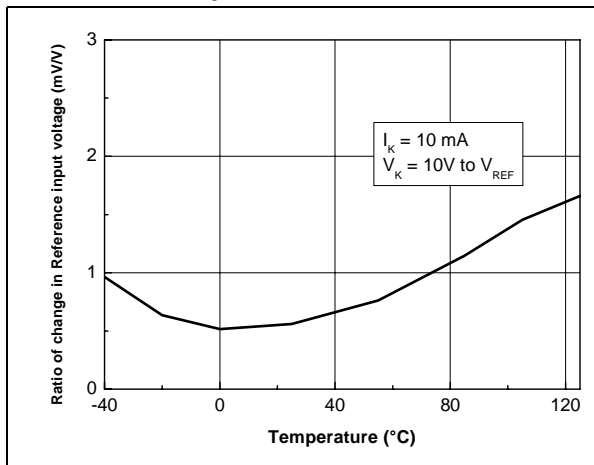

Figure 10. Test circuit for  $V_{KA} > V_{REF}$

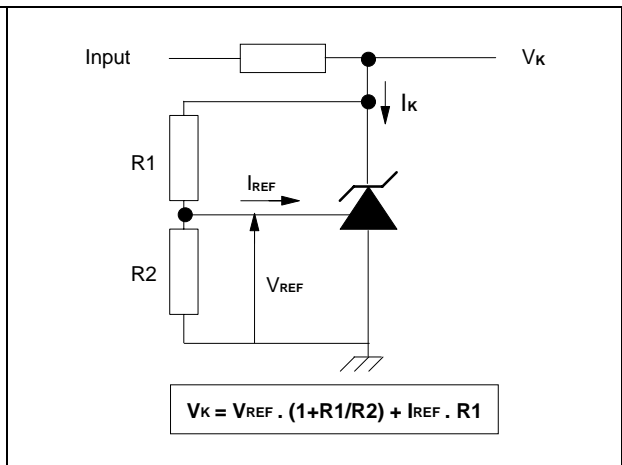

Figure 11. Phase and gain vs frequency

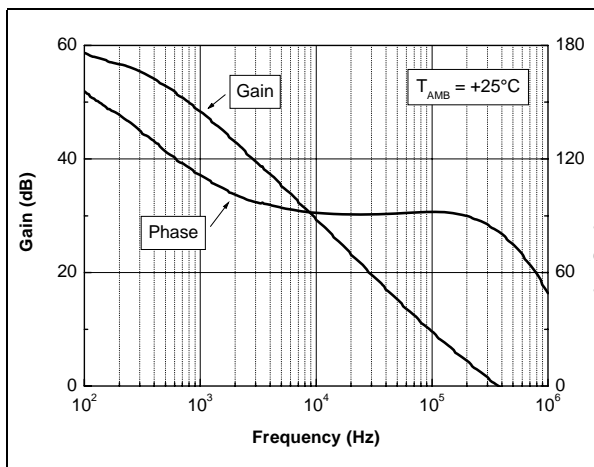

Figure 12. Test circuit for phase and gain measurement

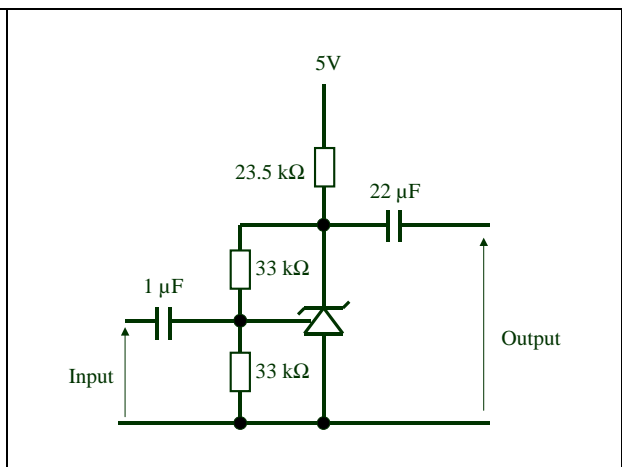

Figure 13. Test circuit for pulse response at  $I_K=100\ \mu\text{A}$

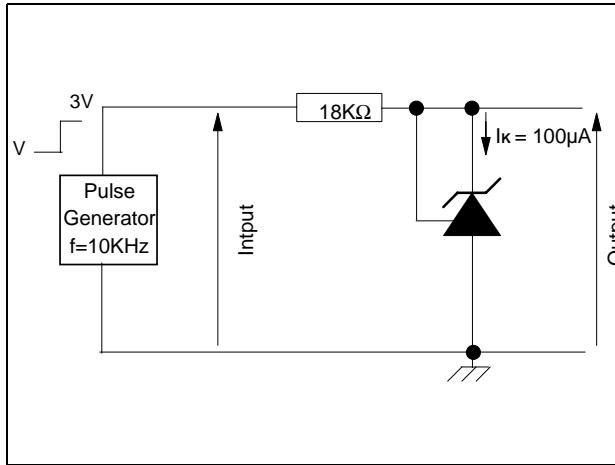

Figure 14. Test circuit for pulse response at  $I_K = 1\ \text{mA}$

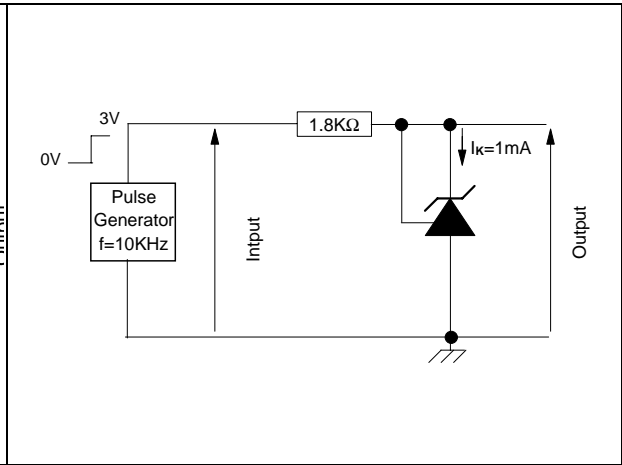

Figure 15. Pulse response at  $I_K = 100\ \mu\text{A}$

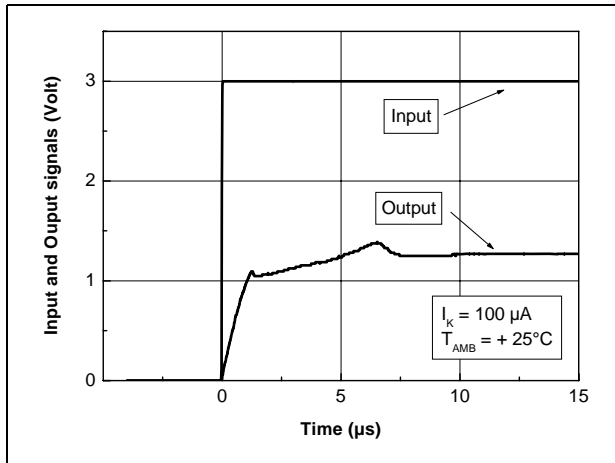

Figure 16. Pulse response at  $I_K = 1\ \text{mA}$

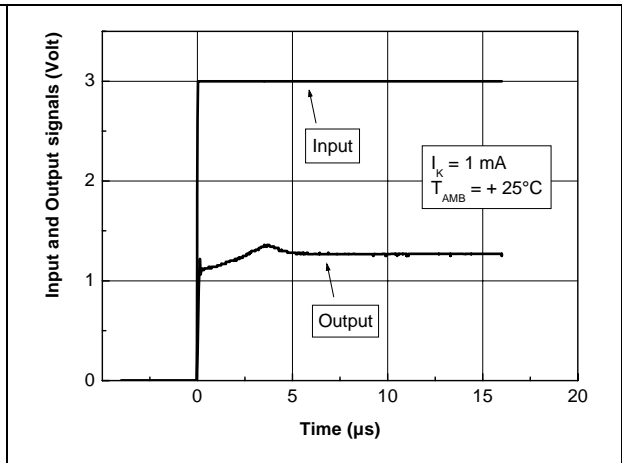

Figure 17. Pulse response at  $I_K = 100\ \mu\text{A}$

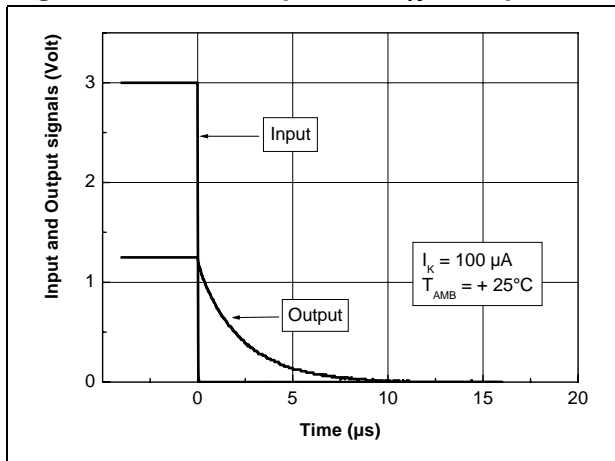

Figure 18. Pulse response at  $I_K = 1\ \text{mA}$

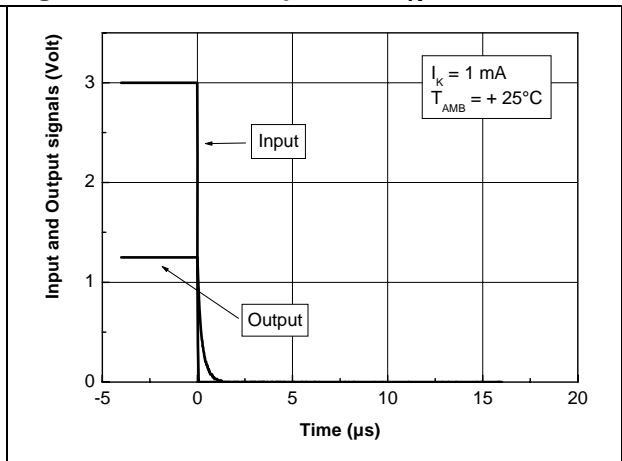

Figure 19. Equivalent input noise vs frequency

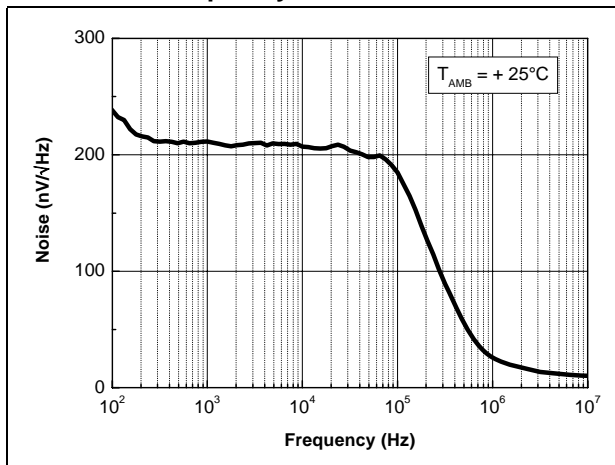
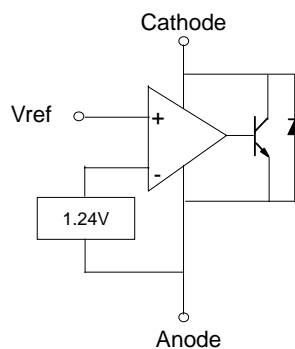

Figure 20. Block diagram



### 3 Package information

In order to meet environmental requirements, STMicroelectronics offers these devices in ECOPACK<sup>®</sup> packages. These packages have a lead-free second level interconnect. The category of second level interconnect is marked on the package and on the inner box label, in compliance with JEDEC Standard JESD97. The maximum ratings related to soldering conditions are also marked on the inner box label. ECOPACK is an STMicroelectronics trademark. ECOPACK specifications are available at: [www.st.com](http://www.st.com).

Figure 21. SOT23-3 package mechanical drawing

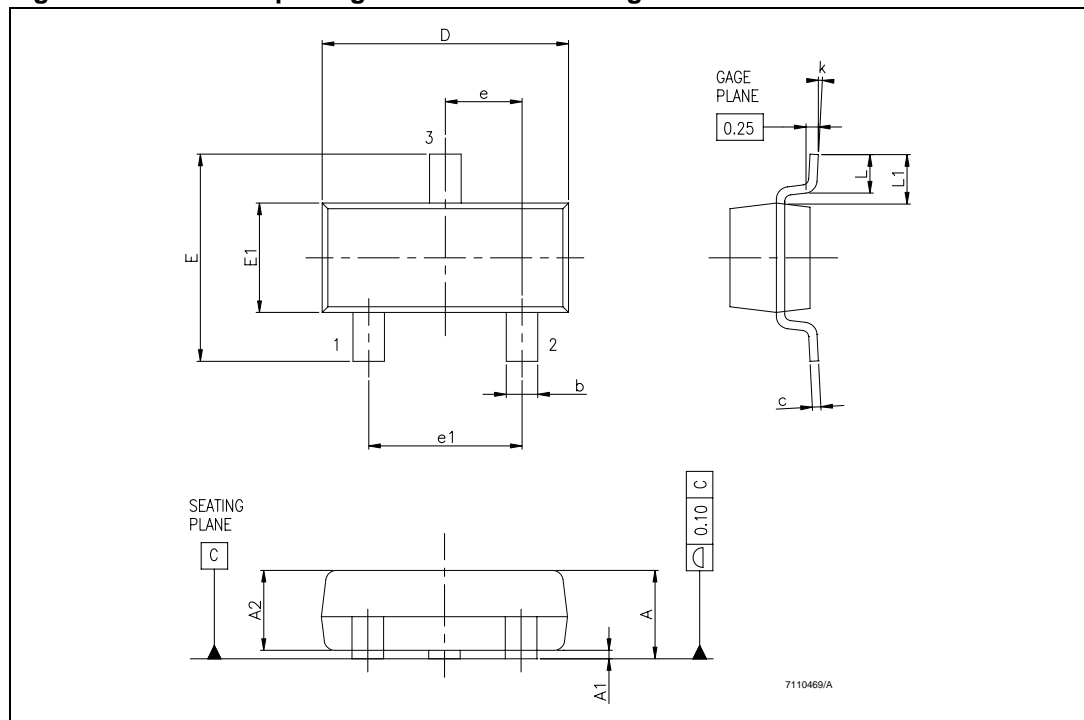

Table 4. SOT23-3 package mechanical data

Ref.	Dimensions					
	Millimeters			Mils		
	Min.	Typ.	Max.	Min.	Typ.	Max.
A	0.890		1.120	35.05		44.12
A1	0.010		0.100	0.39		3.94
A2	0.880	0.950	1.020	34.65	37.41	40.17
b	0.300		0.500	11.81		19.69
C	0.080		0.200	3.15		7.88
D	2.800	2.900	3.040	110.26	114.17	119.72
E	2.100		2.64	82.70		103.96
E1	1.200	1.300	1.400	47.26	51.19	55.13
e		0.950			37.41	
e1		1.900			74.82	
L	0.400		0.600	15.75		23.63
L1		0.540			21.27	
k	0°		8°	0°		8°

## 4 Ordering information

**Table 5. Order codes**

Precision	Order code	Temperature range	Package	Packing	Marking
1%	TS432ILT	-40° C to +85° C	SOT23-3	Tape & reel	L235
0.5%	TS432AILT				L236

## 5 Revision history

**Table 6. Document revision history**

Date	Revision	Changes
16-Dec-2002	1	Initial release.
7-Apr-2008	2	Corrected package mechanical data. Updated document format.

**Please Read Carefully:**

Information in this document is provided solely in connection with ST products. STMicroelectronics NV and its subsidiaries ("ST") reserve the right to make changes, corrections, modifications or improvements, to this document, and the products and services described herein at any time, without notice.

All ST products are sold pursuant to ST's terms and conditions of sale.

Purchasers are solely responsible for the choice, selection and use of the ST products and services described herein, and ST assumes no liability whatsoever relating to the choice, selection or use of the ST products and services described herein.

No license, express or implied, by estoppel or otherwise, to any intellectual property rights is granted under this document. If any part of this document refers to any third party products or services it shall not be deemed a license grant by ST for the use of such third party products or services, or any intellectual property contained therein or considered as a warranty covering the use in any manner whatsoever of such third party products or services or any intellectual property contained therein.

**UNLESS OTHERWISE SET FORTH IN ST'S TERMS AND CONDITIONS OF SALE ST DISCLAIMS ANY EXPRESS OR IMPLIED WARRANTY WITH RESPECT TO THE USE AND/OR SALE OF ST PRODUCTS INCLUDING WITHOUT LIMITATION IMPLIED WARRANTIES OF MERCHANTABILITY, FITNESS FOR A PARTICULAR PURPOSE (AND THEIR EQUIVALENTS UNDER THE LAWS OF ANY JURISDICTION), OR INFRINGEMENT OF ANY PATENT, COPYRIGHT OR OTHER INTELLECTUAL PROPERTY RIGHT.**

**UNLESS EXPRESSLY APPROVED IN WRITING BY AN AUTHORIZED ST REPRESENTATIVE, ST PRODUCTS ARE NOT RECOMMENDED, AUTHORIZED OR WARRANTED FOR USE IN MILITARY, AIR CRAFT, SPACE, LIFE SAVING, OR LIFE SUSTAINING APPLICATIONS, NOR IN PRODUCTS OR SYSTEMS WHERE FAILURE OR MALFUNCTION MAY RESULT IN PERSONAL INJURY, DEATH, OR SEVERE PROPERTY OR ENVIRONMENTAL DAMAGE. ST PRODUCTS WHICH ARE NOT SPECIFIED AS "AUTOMOTIVE GRADE" MAY ONLY BE USED IN AUTOMOTIVE APPLICATIONS AT USER'S OWN RISK.**

Resale of ST products with provisions different from the statements and/or technical features set forth in this document shall immediately void any warranty granted by ST for the ST product or service described herein and shall not create or extend in any manner whatsoever, any liability of ST.

ST and the ST logo are trademarks or registered trademarks of ST in various countries.

Information in this document supersedes and replaces all information previously supplied.

The ST logo is a registered trademark of STMicroelectronics. All other names are the property of their respective owners.

© 2008 STMicroelectronics - All rights reserved

STMicroelectronics group of companies



Australia - Belgium - Brazil - Canada - China - Czech Republic - Finland - France - Germany - Hong Kong - India - Israel - Italy - Japan - Malaysia - Malta - Morocco - Singapore - Spain - Sweden - Switzerland - United Kingdom - United States of America

[www.st.com](http://www.st.com)



## Looking for pricing, stock, or lifecycle information?

Click below to explore more details on WIN SOURCE:

-  [View TS432AILT](#) on WIN SOURCE
-  [STMicroelectronics](#) Information

## Optimize Your Supply Chain with WIN SOURCE Solutions

-  Global Sourcing Solution
-  Obsolete Management
-  Cost Control Management
-  Shortage Management
-  Alternative Solution
-  Excess Inventory Management