



THE DATASHEET OF TSS721ADR



METER-BUS TRANSCEIVER

 Check for Samples: [TSS721A](#)

FEATURES

- **Meter-Bus Transceiver (for Slave) Meets Standard EN1434-3**
- **Receiver Logic With Dynamic Level Recognition**
- **Adjustable Constant-Current Sink via Resistor**
- **Polarity Independent**
- **Power-Fail Function**
- **Module Supply Voltage Switch**
- **3.3-V Constant Voltage Source**
- **Remote Powering**
- **Up to 9600 Baud in Half Duplex for UART Protocol**
- **Slave Power Support**
 - Supply From Meter-Bus via Output VDD
 - Supply From Meter-Bus via Output VDD or From Backup Battery
 - Supply From Battery – Meter-Bus Active for Data Transmission Only

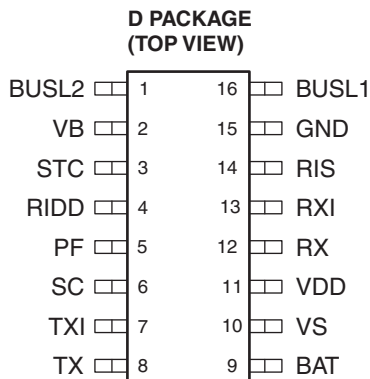

DESCRIPTION

TSS721A is a single chip transceiver developed for Meter-Bus standard (EN1434-3) applications.

The TSS721A interface circuit adjusts the different potentials between a slave system and the Meter-Bus master. The connection to the bus is polarity independent and supports full galvanic slave isolation with optocouplers.

The circuit is supplied by the master via the bus. Therefore, this circuit offers no additional load for the slave battery. A power-fail function is integrated.

The receiver has dynamic level recognition, and the transmitter has a programmable current sink.

A 3.3-V voltage regulator, with power reserve for a delayed switch off at bus fault, is integrated.

Table 1. ORDERING INFORMATION⁽¹⁾⁽²⁾

T _A	PACKAGE		ORDERABLE PART NUMBER
0°C to 70°C	SOIC – D	Reel of 2500	TSS721ADR

(1) For the most current package and ordering information, see the Package Option Addendum at the end of this document, or see the TI web site at www.ti.com.

(2) Package drawings, thermal data, and symbolization are available at www.ti.com/packaging.



Please be aware that an important notice concerning availability, standard warranty, and use in critical applications of Texas Instruments semiconductor products and disclaimers thereto appears at the end of this data sheet.

FUNCTIONAL DESCRIPTION

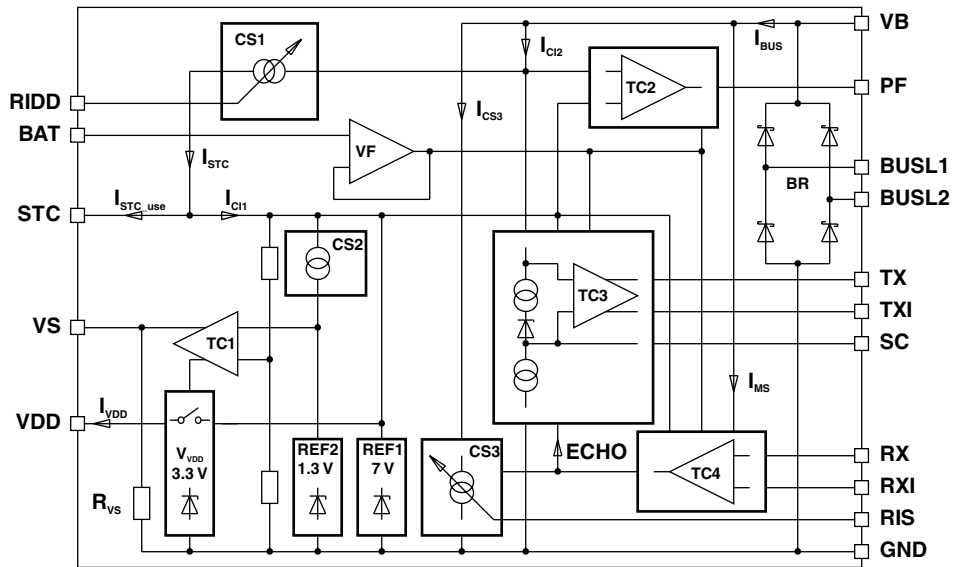

Figure 1. Functional Schematic

Table 2. Terminal Functions

TERMINAL		DESCRIPTION
NAME	NO.	
BUSL2	1	Meter-Bus
VB	2	Differential bus voltage after rectifier
STC	3	Support capacitor
RIDD	4	Current adjustment input
PF	5	Power fail output
SC	6	Sampling capacitor
TXI	7	Data output inverted
TX	8	Data output
BAT	9	Logic level adjust
VS	10	Switch for bus or battery supply output
VDD	11	Voltage regulator output
RX	12	Data input
RXI	13	Data input inverted
RIS	14	Adjust input for modulation current
GND	15	Ground
BUSL1	16	Meter-Bus

Data Transmission, Master to Slave

The mark level on the bus lines $V_{BUS} = \text{MARK}$ is defined by the difference of BUSL1 and BUSL2 at the slave. It is dependent on the distance of Master to Slave, which affects the voltage drop on the wire. To make the receiver independent, a dynamic reference level on the SC pin is used for the voltage comparator TC3 (see Figure 2).

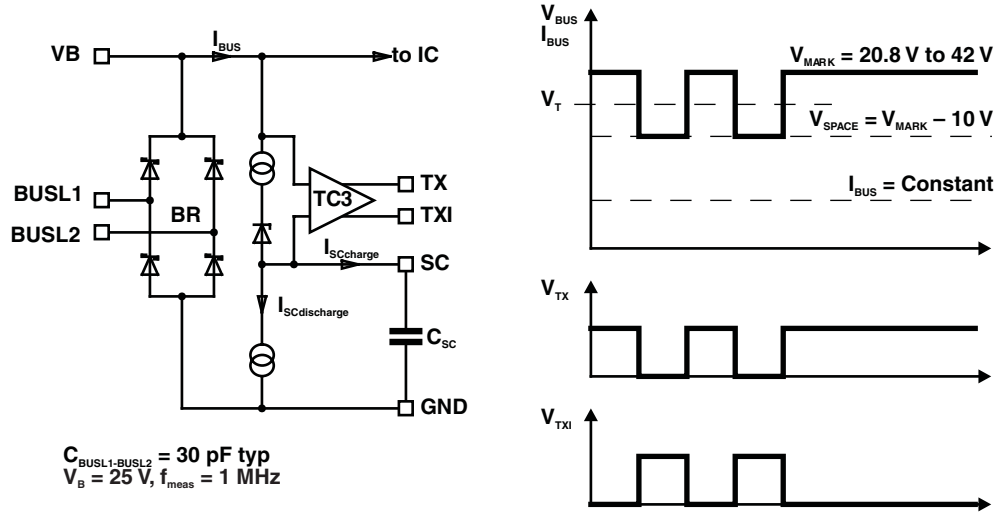

Figure 2. Data Transmission, Master to Slave

A capacitor C_{SC} at pin SC is charged by a current $I_{SC\text{charge}}$ and is discharged with a current $I_{SC\text{discharge}}$ where:

$$I_{SC\text{discharge}} = \frac{I_{SC\text{charge}}}{40} \text{ (typ)} \quad (1)$$

This ratio is necessary to run any kind of UART protocol independent of the data contents. (for example, if an 11-bit UART protocol is transmitted with all data bits at 0 and only the stop bit at 1). There must be sufficient time to recharge the capacitor C_{SC} . The input level detector TC3 detects voltage modulations from the master, $V_{BUS} = \text{SPACE/MARK}$ conditions, and switches the inverted output TXI and the non-inverted output TX.

Data Transmission, Slave to Master

The device uses current modulation to transmit information from the slave to the master while the bus voltage remains constant. The current source CS3 modulates the bus current and the master detects the modulation. The constant current source CS3 is controlled by the inverted input RXI or the non-inverted input RX. The current source CS3 can be programmed by an external resistor R_{RIS} . The modulation supply current I_{MS} flows in addition to the current source CS3 during the modulation time.

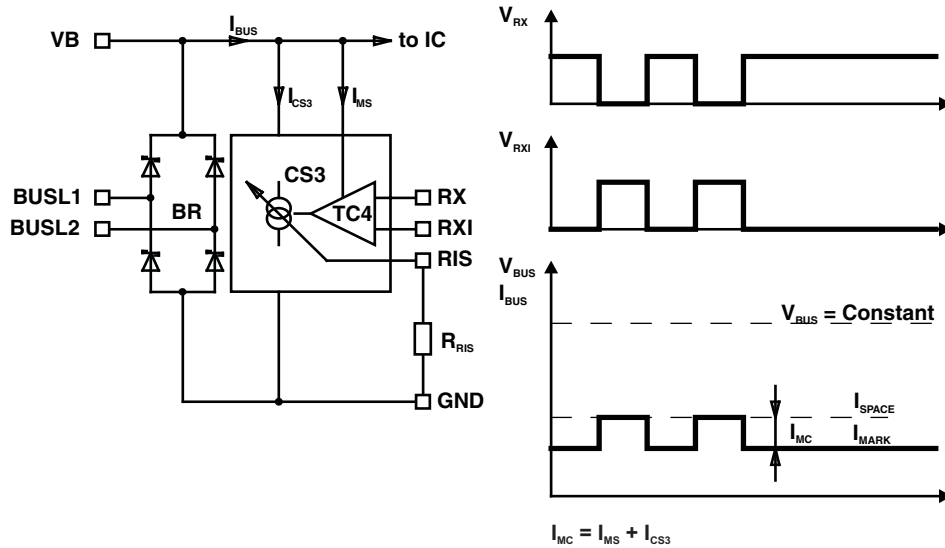

Figure 3. Data Transmission, Slave to Master

Because the TSS721A is configured for half-duplex only, the current modulation from RX or RXI is repeated concurrently as ECHO on the outputs TX and TXI. If the slave, as well as the master, is trying to send information via the lines, the added signals appear on the outputs TX and TXI, which indicates the data collision to the slave (see Figure 1).

The bus topology requires a constant current consumption by each connected slave.

To calculate the value of the programming resistor R_{RIS} , use the formula shown in Figure 4.

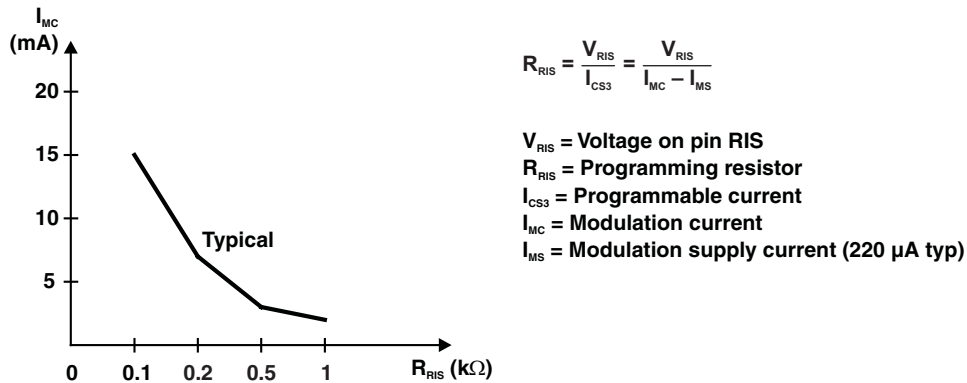

Figure 4. Calculate Programming Resistor R_{RIS}

Slave Supply, 3.3 V

The TSS721A has an internal 3.3-V voltage regulator. The output power of this voltage regulator is supplied by the storage capacitor C_{STC} at pin STC. The storage capacitor C_{STC} at pin STC is charged with constant current I_{STC_use} from the current source CS1. The maximum capacitor voltage is limited to REF1. The charge current I_{STC} has to be defined by an external resistor at pin RIDD.

The adjustment resistor R_{RIDD} can be calculated using Equation 2.

$$R_{RID} = 25 \frac{V_{RIDD}}{I_{STC}} = 25 \frac{V_{RIDD}}{I_{STC_use} + I_{IC1}} \quad (2)$$

Where,

- I_{STC} = current from current source CS1
- I_{STC_use} = charge current for support capacitor
- I_{IC1} = internal current
- V_{RIDD} = voltage on pin RIDD
- R_{RIDD} = value of adjustment resistor

The voltage level of the storage capacitor C_{STC} is monitored with comparator TC1. Once the voltage V_{STC} reaches V_{VDD_on} , the switch S_{VDD} connects the stabilized voltage V_{VDD} to pin VDD. VDD is turned off if the voltage V_{STC} drops below the V_{VDD_off} level.

Voltage variations on the capacitor C_{STC} create bus current changes (see Figure 5).

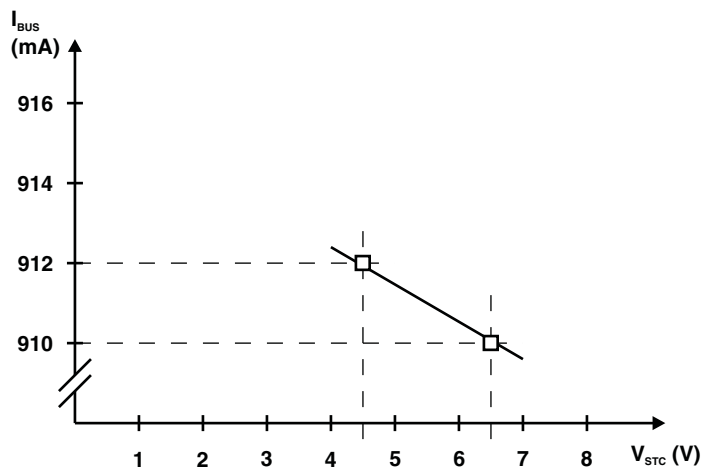

Figure 5. Single Mode Bus Load

At a bus fault the shut down time of VDD (t_{off}) in which data storage can be performed depends on the system current I_{VDD} and the value of capacitor C_{STC} . See Figure 6, which shows a correlation between the shutdown of the bus voltage V_{BUS} and V_{DD_off} and t_{off} for dimensioning the capacitor.

The output VS is meant for slave systems that are driven by the bus energy, as well as from a battery should the bus line voltage fail. The switching of VS is synchronized with VDD and is controlled by the comparator TC1. An external transistor at the output VS allows switching from the Meter-Bus remote supply to battery.

Power On/Off

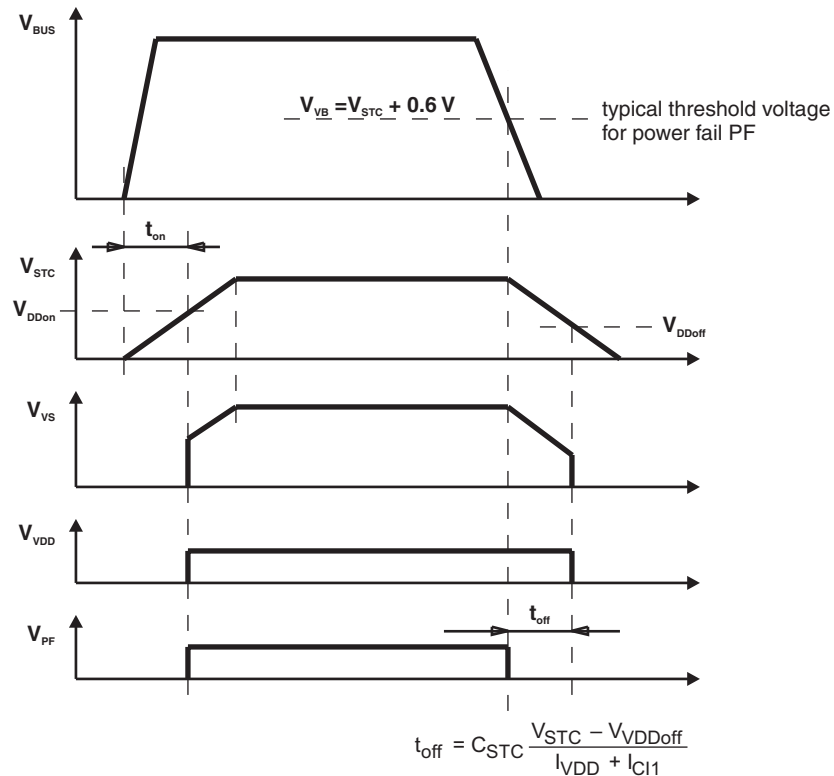

Figure 6. Power On/Off Timing

Power Fail Function

Because of the rectifier bridge BR at the input, BUSL1, and BUSL2, the TSS721A is polarity independent. The pin VB to ground (GND) delivers the bus voltage V_{VB} less the voltage drop over the rectifier BR. The voltage comparator TC2 monitors the bus voltage. If the voltage $V_{VB} > V_{STC} + 0.6\text{ V}$, then the output PF = 1. The output level PF = 0 (power fail) provides a warning of a critical voltage drop to the microcontroller to save the data immediately.

ABSOLUTE MAXIMUM RATINGS

over operating free-air temperature range (unless otherwise noted)

V_{MB}	Voltage, BUSL1 to BUSL2		± 50 V
V_I	Input voltage range	RX and RXI	-0.3 V to 5.5 V
		BAT	-0.3 V to 5.5 V
T_J	Operating junction temperature range		-25°C to 150°C
T_A	Operating free-air temperature range		-25°C to 85°C
T_{STG}	Storage temperature range		-65°C to 150°C
	Power derating factor, junction to ambient		8 mW/°C

RECOMMENDED OPERATING CONDITIONS⁽¹⁾

		MIN	MAX	UNIT	
V_{MB}	Bus voltage, BUSL2 – BUSL1	Receiver	10.8	42	V
		Transmitter	12	42	
V_I	Input voltage	VB (receive mode)	9.3		V
		BAT ⁽²⁾	2.5	3.8	
R_{RIDD}	RIDD resistor	13	80	k Ω	
R_{RIS}	RIS resistor	100		Ω	
T_A	Operating free-air temperature	-25	85	°C	

(1) All voltage values are measured with respect to the GND terminal unless otherwise noted.

 (2) $V_{BAT(max)} \leq V_{STC} - 1$ V

ELECTRICAL CHARACTERISTICS⁽¹⁾

over operating free-air temperature range (unless otherwise noted)

PARAMETER	TEST CONDITIONS	MIN	TYP	MAX	UNIT
ΔV_{BR}	Voltage drop at rectifier BR $I_{BUS} = 3$ mA			1.5	V
ΔV_{CS1}	Voltage drop at current source CS1 $R_{RIDD} = 13$ k Ω			1.8	V
I_{BUS}	BUS current $V_{STC} = 6.5$ V, $I_{MC} = 0$ mA	$R_{RIDD} = 13$ k Ω		3	mA
		$R_{RIDD} = 30$ k Ω		1.5	
ΔI_{BUS}	BUS current accuracy $\Delta V_{BUS} = 10$ V, $I_{MC} = 0$ mA, $R_{RIDD} = 13$ k Ω to 30 k Ω			2	%
I_{CC}	Supply current $V_{STC} = 6.5$ V, $I_{MC} = 0$ mA, $V_{BAT} = 3.8$ V, $R_{RIDD} = 13$ k Ω ⁽²⁾			650	μ A
I_{CI1}	CI1 current $V_{STC} = 6.5$ V, $I_{MC} = 0$ mA, $V_{BAT} = 3.8$ V, $R_{RIDD} = 13$ k Ω , $V_{BUS} = 6.5$ V, RX/RXI = off ⁽²⁾			350	μ A
I_{BAT}	BAT current	-0.5		0.5	μ A
$I_{BAT} + I_{VDD}$	BAT plus VDD current $V_{BUS} = 0$ V, $V_{STC} = 0$ V	-0.5		0.5	μ A
V_{VDD}	VDD voltage $-I_{VDD} = 1$ mA, $V_{STC} = 6.5$ V	3.1		3.4	V
R_{VDD}	VDD resistance $-I_{VDD} = 2$ to 8 mA, $V_{STC} = 4.5$ V			5	Ω
V_{STC}	STC voltage $V_{DD} = \text{on}$, $V_S = \text{on}$		5.6	6.4	V
		$V_{DD} = \text{off}$, $V_S = \text{off}$	3.8	4.3	
		$I_{VDD} < I_{STC_use}$	6.5	7.5	
I_{STC_use}	STC current $V_{STC} = 5$ V	$R_{RIDD} = 30$ k Ω	0.65	1.1	mA
		$R_{RIDD} = 13$ k Ω	1.85	2.4	
V_{RIDD}	RIDD voltage $R_{RIDD} = 30$ k Ω	1.23		1.33	V
V_{VS}	VS voltage $V_{DD} = \text{on}$, $I_{VS} = -5$ μ A	$V_{STC} - 0.4$		V_{STC}	V
R_{VS}	VS resistance $V_{DD} = \text{off}$	0.3		1	M Ω
V_{PF}	PF voltage $V_{STC} = 6.5$ V	$V_{VB} = V_{STC} + 0.8$ V, $I_{PF} = -100$ μ A	$V_{BAT} - 0.6$	V_{BAT}	V
		$V_{VB} = V_{STC} + 0.3$ V, $I_{PF} = 1$ μ A	0	0.6	
		$V_{VB} = V_{STC} + 0.3$ V, $I_{PF} = 5$ μ A	0	0.9	

(1) All voltage values are measured with respect to the GND terminal, unless otherwise noted.

 (2) Inputs RX/RXI and outputs TX/TXI are open, $I_{CC} = I_{CI1} + I_{CI2}$

ELECTRICAL CHARACTERISTICS⁽¹⁾ (continued)

over operating free-air temperature range (unless otherwise noted)

PARAMETER	TEST CONDITIONS	MIN	TYP	MAX	UNIT
t_{on} Turn-on time	$C_{STC} = 50 \mu\text{F}$, Bus voltage slew rate: 1 V/ μs			3	s

RECEIVER SECTION ELECTRICAL CHARACTERISTICS⁽¹⁾

over operating free-air temperature range (unless otherwise noted)

PARAMETER	TEST CONDITIONS	MIN	TYP	MAX	UNIT
V_T	See Figure 2	MARK – 8.2		MARK – 5.7	V
V_{SC} SC voltage				V_{VB}	V
$I_{SCcharge}$ SC charge current	$V_{SC} = 24 \text{ V}$, $V_{VB} = 36 \text{ V}$	–15		–40	μA
$I_{SCdischarge}$ SC discharge current	$V_{SC} = V_{VB} = 24 \text{ V}$	0.3		$-0.033 \times I_{SCcharge}$	μA
V_{OH} High-level output voltage (TX, TXI)	$I_{TX}/I_{TXI} = -100 \mu\text{A}$ (see Figure 2)	$V_{BAT} - 0.6$		V_{BAT}	V
V_{OL} Low-level output voltage (TX, TXI)	$I_{TX}/I_{TXI} = 100 \mu\text{A}$	0		0.5	V
	$I_{TX} = 1.1 \text{ mA}$	0		1.5	V
I_{TX} I_{TXI} TX, TXI current	$V_{TX} = 7.5$, $V_{VB} = 12 \text{ V}$, $V_{STC} = 6 \text{ V}$, $V_{BAT} = 3.8 \text{ V}$			10	μA

(1) All voltage values are measured with respect to the GND terminal, unless otherwise noted.

TRANSMITTER SECTION ELECTRICAL CHARACTERISTICS⁽¹⁾

over operating free-air temperature range (unless otherwise noted)

PARAMETER	TEST CONDITIONS	MIN	TYP	MAX	UNIT
I_{MC} MC voltage	$R_{RIS} = 100 \Omega$	11.5		19.5	mA
V_{RIS} RIS voltage	$R_{RIS} = 100 \Omega$	1.4		1.7	V
	$R_{RIS} = 1000 \Omega$	1.5		1.8	V
V_{IH} High-level input voltage (RX, RXI)	See Figure 3 , see ⁽²⁾	$V_{BAT} - 0.8$		5.5	V
V_{IL} Low-level input voltage (RX, RXI)	See Figure 3	0		0.8	V
I_{RX} RX current	$V_{RX} = V_{BAT} = 3 \text{ V}$, $V_{VB} = V_{STC} = 0 \text{ V}$	–0.5		0.5	μA
	$V_{RX} = 0 \text{ V}$, $V_{BAT} = 3 \text{ V}$, $V_{STC} = 6.5 \text{ V}$	–10		–40	μA
I_{RXI} RXI current	$V_{RXI} = V_{BAT} = 3 \text{ V}$, $V_{VB} = V_{STC} = 0 \text{ V}$	10		40	μA
	$V_{RXI} = V_{BAT} = 3 \text{ V}$, $V_{STC} = 6.5 \text{ V}$	10		40	μA

(1) All voltage values are measured with respect to the GND terminal, unless otherwise noted.

(2) $V_{IH}(\text{max}) = 5.5 \text{ V}$ is valid only when $V_{STC} > = 6.5 \text{ V}$.

APPLICATION INFORMATION

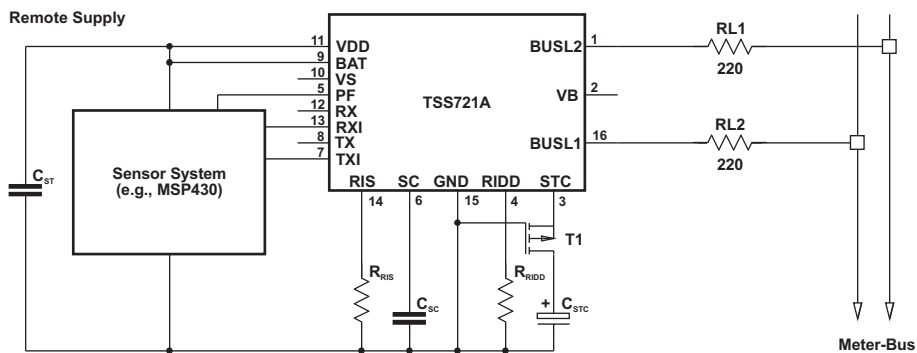

$R_{RIDD} = 30 \text{ k}\Omega$	$C_{STC} \leq 220 \mu\text{F}$	single load 1UL
$R_{RIDD} = 13 \text{ k}\Omega$	$C_{STC} \leq 470 \mu\text{F}$	double load 2UL

NOTE: Transistor T1 should be a BSS84.

Figure 7. Basic Application Circuit Using Support Capacitor $C_{STC} > 50 \mu\text{F}$

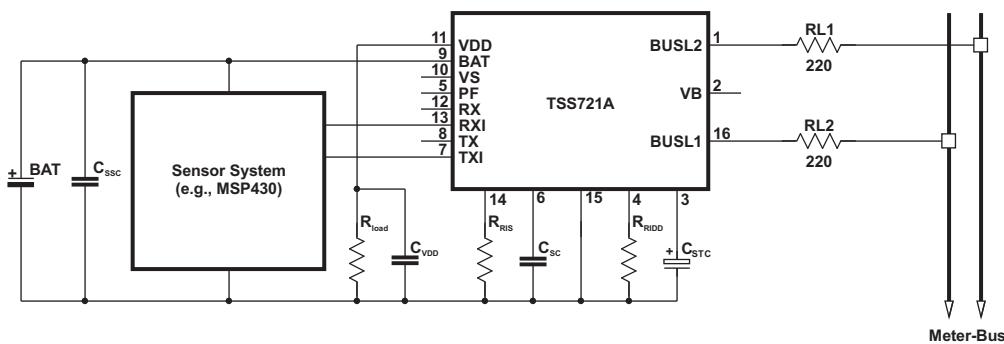

- C_{SSC} - system stabilising capacitor
- C_{STC} - support capacitor
- C_{SC} - sampling capacitor
- C_{VDD} - stabilising capacitor (100 nF)
- $C_{STC}:C_{VDD} \geq 4:1$
- R_{RIDD} - slave-current adjustment resistor
- R_{RIS} - modulation-current resistor
- RL1, RL2 - protection resistors
- R_{LOAD} - discharge resistor (100 kΩ recommended)

Figure 8. Basic Application Circuit for Supply From Battery

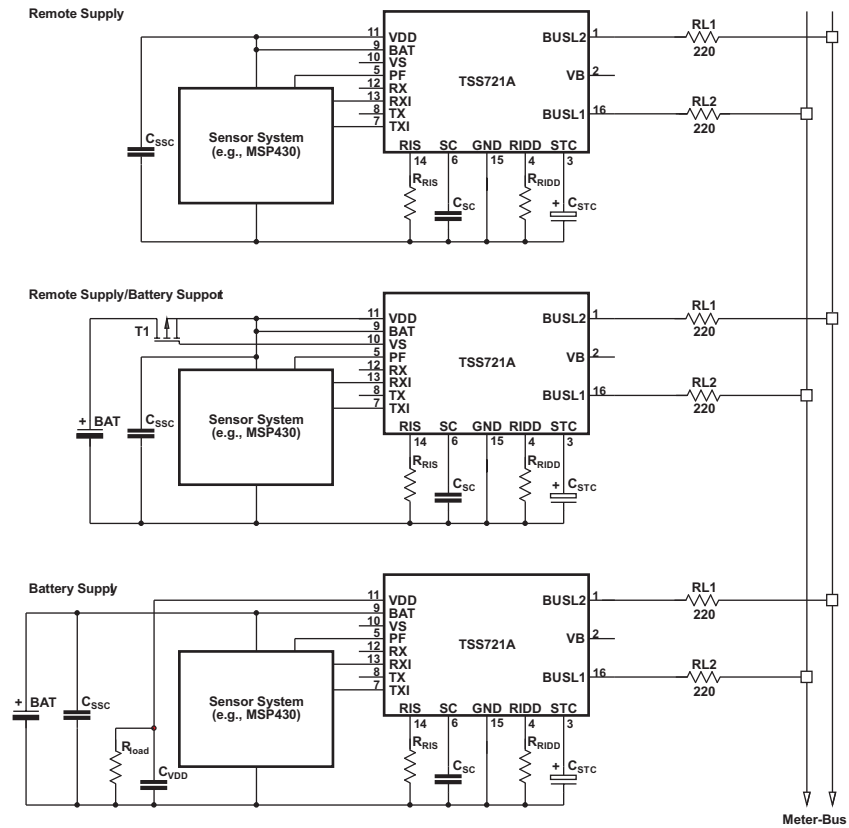

NOTE: R_{DSon} of the transistor T1 (BSS84) at low battery voltage must be considered during application design.

Figure 9. Basic Applications for Different Supply Modes

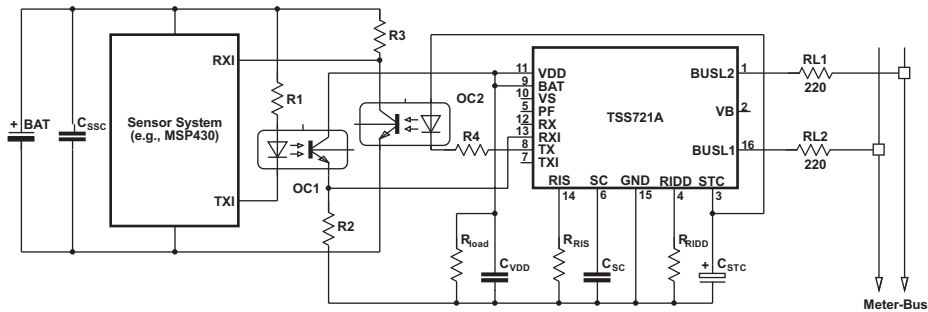

Figure 10. Basic Optocoupler Application

PACKAGING INFORMATION

Orderable Device	Status (1)	Package Type	Package Drawing	Pins	Package Qty	Eco Plan (2)	Lead finish/ Ball material (6)	MSL Peak Temp (3)	Op Temp (°C)	Device Marking (4/5)	Samples
TSS721ADR	ACTIVE	SOIC	D	16	2500	RoHS & Green	NIPDAU	Level-1-260C-UNLIM	-25 to 85	TSS721A	Samples

(1) The marketing status values are defined as follows:

ACTIVE: Product device recommended for new designs.

LIFEBUY: TI has announced that the device will be discontinued, and a lifetime-buy period is in effect.

NRND: Not recommended for new designs. Device is in production to support existing customers, but TI does not recommend using this part in a new design.

PREVIEW: Device has been announced but is not in production. Samples may or may not be available.

OBSELETE: TI has discontinued the production of the device.

(2) **RoHS:** TI defines "RoHS" to mean semiconductor products that are compliant with the current EU RoHS requirements for all 10 RoHS substances, including the requirement that RoHS substance do not exceed 0.1% by weight in homogeneous materials. Where designed to be soldered at high temperatures, "RoHS" products are suitable for use in specified lead-free processes. TI may reference these types of products as "Pb-Free".

RoHS Exempt: TI defines "RoHS Exempt" to mean products that contain lead but are compliant with EU RoHS pursuant to a specific EU RoHS exemption.

Green: TI defines "Green" to mean the content of Chlorine (Cl) and Bromine (Br) based flame retardants meet JS709B low halogen requirements of <=1000ppm threshold. Antimony trioxide based flame retardants must also meet the <=1000ppm threshold requirement.

(3) MSL, Peak Temp. - The Moisture Sensitivity Level rating according to the JEDEC industry standard classifications, and peak solder temperature.

(4) There may be additional marking, which relates to the logo, the lot trace code information, or the environmental category on the device.

(5) Multiple Device Markings will be inside parentheses. Only one Device Marking contained in parentheses and separated by a "~" will appear on a device. If a line is indented then it is a continuation of the previous line and the two combined represent the entire Device Marking for that device.

(6) Lead finish/Ball material - Orderable Devices may have multiple material finish options. Finish options are separated by a vertical ruled line. Lead finish/Ball material values may wrap to two lines if the finish value exceeds the maximum column width.

Important Information and Disclaimer:The information provided on this page represents TI's knowledge and belief as of the date that it is provided. TI bases its knowledge and belief on information provided by third parties, and makes no representation or warranty as to the accuracy of such information. Efforts are underway to better integrate information from third parties. TI has taken and continues to take reasonable steps to provide representative and accurate information but may not have conducted destructive testing or chemical analysis on incoming materials and chemicals. TI and TI suppliers consider certain information to be proprietary, and thus CAS numbers and other limited information may not be available for release.

In no event shall TI's liability arising out of such information exceed the total purchase price of the TI part(s) at issue in this document sold by TI to Customer on an annual basis.

D (R-PDSO-G16)

PLASTIC SMALL OUTLINE



4040047-6/M 06/11

- NOTES:
- A. All linear dimensions are in inches (millimeters).
 - B. This drawing is subject to change without notice.
 -  C. Body length does not include mold flash, protrusions, or gate burrs. Mold flash, protrusions, or gate burrs shall not exceed 0.006 (0,15) each side.
 -  D. Body width does not include interlead flash. Interlead flash shall not exceed 0.017 (0,43) each side.
 - E. Reference JEDEC MS-012 variation AC.

IMPORTANT NOTICE AND DISCLAIMER

TI PROVIDES TECHNICAL AND RELIABILITY DATA (INCLUDING DATA SHEETS), DESIGN RESOURCES (INCLUDING REFERENCE DESIGNS), APPLICATION OR OTHER DESIGN ADVICE, WEB TOOLS, SAFETY INFORMATION, AND OTHER RESOURCES "AS IS" AND WITH ALL FAULTS, AND DISCLAIMS ALL WARRANTIES, EXPRESS AND IMPLIED, INCLUDING WITHOUT LIMITATION ANY IMPLIED WARRANTIES OF MERCHANTABILITY, FITNESS FOR A PARTICULAR PURPOSE OR NON-INFRINGEMENT OF THIRD PARTY INTELLECTUAL PROPERTY RIGHTS.

These resources are intended for skilled developers designing with TI products. You are solely responsible for (1) selecting the appropriate TI products for your application, (2) designing, validating and testing your application, and (3) ensuring your application meets applicable standards, and any other safety, security, regulatory or other requirements.

These resources are subject to change without notice. TI grants you permission to use these resources only for development of an application that uses the TI products described in the resource. Other reproduction and display of these resources is prohibited. No license is granted to any other TI intellectual property right or to any third party intellectual property right. TI disclaims responsibility for, and you will fully indemnify TI and its representatives against, any claims, damages, costs, losses, and liabilities arising out of your use of these resources.

TI's products are provided subject to [TI's Terms of Sale](#) or other applicable terms available either on [ti.com](https://www.ti.com) or provided in conjunction with such TI products. TI's provision of these resources does not expand or otherwise alter TI's applicable warranties or warranty disclaimers for TI products.

TI objects to and rejects any additional or different terms you may have proposed.

Mailing Address: Texas Instruments, Post Office Box 655303, Dallas, Texas 75265
Copyright © 2024, Texas Instruments Incorporated

Looking for pricing, stock, or lifecycle information?

Click below to explore more details on WIN SOURCE:

 [View TSS721ADR](#) on WIN SOURCE

 [Texas Instruments](#) Information

Optimize Your Supply Chain with WIN SOURCE Solutions

-  Global Sourcing Solution
-  Obsolete Management
-  Cost Control Management
-  Shortage Management
-  Alternative Solution
-  Excess Inventory Management