



# THE DATASHEET OF TSV624IPT



## Rail-to-rail input/output, 29 $\mu$ A, 420 kHz CMOS operational amplifiers

Datasheet - production data

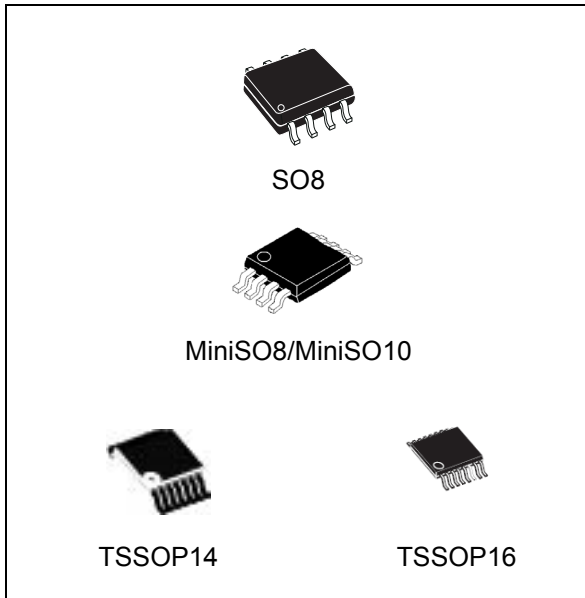

### Applications

- Battery-powered applications
- Portable devices
- Signal conditioning
- Active filtering
- Medical instrumentation

### Description

The TSV622, TSV622A, TSV623, TSV623A, TSV624, TSV624A, TSV625, and TSV625A dual and quad operational amplifiers offer low voltage, low power operation, and rail-to-rail input and output.

The TSV62x/TSV62xA series feature an excellent speed/power consumption ratio, offering a 420 kHz gain bandwidth product while consuming only 29  $\mu$ A at 5 V supply voltage.

These op-amps are unity gain stable for capacitive loads up to 100 pF. They also feature an ultra-low input bias current and low input offset voltage. TSV623 (dual) and TSV625 (quad) have two shutdown pins to reduce power consumption.

These features make the TSV62x/TSV62xA family ideal for sensor interfaces, battery-supplied and portable applications, and active filtering.

### Features

- Rail-to-rail input and output
- Low power consumption: 29  $\mu$ A typ, 36  $\mu$ A max
- Low supply voltage: 1.5 – 5.5 V
- Gain bandwidth product: 420 kHz typ
- Unity gain stable on 100 pF capacitor
- Low power shutdown mode: 5 nA typ
- Good accuracy: 800  $\mu$ V max (A version)
- Low input bias current: 1 pA typ
- EMI hardened operational amplifiers

### Related products

- See the TSV61x series for more power savings (120 kHz for 9  $\mu$ A)
- See the TSV63x series for higher gain bandwidth (880 kHz for 60  $\mu$ A)

**Table 1. Device summary**

Reference	Dual version		Quad version	
	Without standby	With standby	Without standby	With standby
TSV62x	TSV622	TSV623	TSV624	TSV625
TSV62xA	TSV622A	TSV623A	TSV624A	TSV625A

# Contents

- 1      Package pin connections ..... 3**
- 2      Absolute maximum ratings and operating conditions ..... 4**
- 3      Electrical characteristics ..... 5**
- 4      Application information ..... 13**
  - 4.1    Operating voltages ..... 13
  - 4.2    Rail-to-rail input ..... 13
  - 4.3    Rail-to-rail output ..... 13
  - 4.4    Optimization of DC and AC parameters ..... 14
  - 4.5    Shutdown function (TSV623, TSV625) ..... 14
  - 4.6    Driving resistive and capacitive loads ..... 15
  - 4.7    PCB layouts ..... 15
  - 4.8    Macromodel ..... 15
- 5      Package information ..... 16**
  - 5.1    SO8 package information ..... 17
  - 5.2    MiniSO8 package information ..... 18
  - 5.3    MiniSO10 package information ..... 19
  - 5.4    TSSOP14 package information ..... 20
  - 5.5    TSSOP16 package information ..... 21
- 6      Ordering information ..... 22**
- 7      Revision history ..... 23**

# 1 Package pin connections

Figure 1. Pin connections for each package (top view)

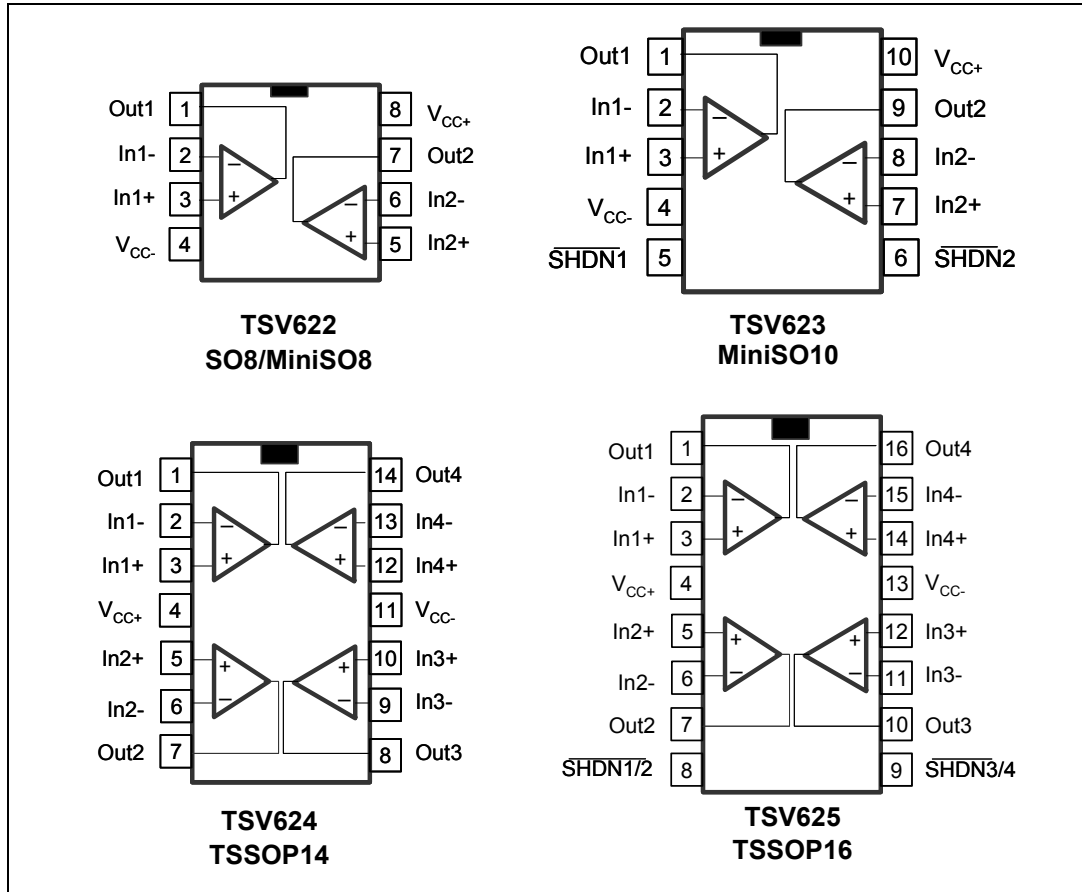

## 2 Absolute maximum ratings and operating conditions

**Table 2. Absolute maximum ratings (AMR)**

Symbol	Parameter	Value	Unit
$V_{CC}$	Supply voltage <sup>(1)</sup>	6	V
$V_{id}$	Differential input voltage <sup>(2)</sup>	$\pm V_{CC}$	
$V_{in}$	Input voltage <sup>(3)</sup>	$(V_{CC-}) - 0.2$ to $(V_{CC+}) + 0.2$	
$I_{in}$	Input current <sup>(4)</sup>	10	mA
$\overline{SHDN}$	Shutdown voltage <sup>(3)</sup>	$(V_{CC-}) - 0.2$ to $(V_{CC+}) + 0.2$	V
$T_{stg}$	Storage temperature	-65 to 150	°C
$R_{thja}$	Thermal resistance junction to ambient <sup>(5) (6)</sup>		°C/W
	MiniSO8	190	
	SO8	125	
	MiniSO10	113	
	TSSOP14	100	
	TSSOP16	95	
$T_j$	Maximum junction temperature	150	°C
ESD	HBM: human body model <sup>(7)</sup>	4	kV
	MM: machine model <sup>(8)</sup>	200	V
	CDM: charged device model <sup>(9)</sup>	1.5	kV
	Latch-up immunity	200	mA

1. All voltage values, except differential voltages are with respect to network ground terminal.
2. Differential voltages are the non-inverting input terminal with respect to the inverting input terminal.
3.  $V_{CC-} - V_{in}$  must not exceed 6 V,  $V_{in}$  must not exceed 6V.
4. Input current must be limited by a resistor in series with the inputs.
5. Short-circuits can cause excessive heating and destructive dissipation.
6.  $R_{th}$  are typical values.
7. Human body model: 100 pF discharged through a 1.5 kΩ resistor between two pins of the device, done for all couples of pin combinations with other pins floating.
8. Machine model: a 200 pF capacitor is charged to the specified voltage, then discharged directly between two pins of the device with no external series resistor (internal resistor < 5 Ω), done for all couples of pin combinations with other pins floating.
9. Charged device model: all pins plus package are charged together to the specified voltage and then discharged directly to ground.

**Table 3. Operating conditions**

Symbol	Parameter	Value	Unit
$V_{CC}$	Supply voltage	1.5 to 5.5	V
$V_{icm}$	Common mode input voltage range	$(V_{CC-}) - 0.1$ to $(V_{CC+}) + 0.1$	
$T_{oper}$	Operating free air temperature range	-40 to 125	°C

### 3 Electrical characteristics

Table 4. Electrical characteristics at  $V_{CC+} = 1.8\text{ V}$  with  $V_{CC-} = 0\text{ V}$ ,  $V_{icm} = V_{CC}/2$ ,  $T_{amb} = 25\text{ }^{\circ}\text{C}$ , and  $R_L$  connected to  $V_{CC}/2$  (unless otherwise specified)

Symbol	Parameter	Conditions	Min.	Typ.	Max.	Unit
<b>DC performance</b>						
$V_{io}$	Offset voltage	TSV62x TSV62xA TSV623AIST - MiniSO10			4 0.8 1	mV
		TSV62x - $T_{min} < T_{op} < T_{max}$ TSV62xA - $T_{min} < T_{op} < T_{max}$ TSV623AIST - $T_{min} < T_{op} < T_{max}$			6 2 2.2	
$\Delta V_{io}/\Delta T$	Input offset voltage drift			2		$\mu\text{V}/^{\circ}\text{C}$
$I_{io}$	Input offset current ( $V_{out} = V_{CC}/2$ )			1	10 <sup>(1)</sup>	pA
		$T_{min} < T_{op} < T_{max}$		1	100	
$I_{ib}$	Input bias current ( $V_{out} = V_{CC}/2$ )			1	10 <sup>(1)</sup>	pA
		$T_{min} < T_{op} < T_{max}$		1	100	
CMR	Common mode rejection ratio $20 \log(\Delta V_{ic}/\Delta V_{io})$	0 V to 1.8 V, $V_{out} = 0.9\text{ V}$	53	74		dB
		$T_{min} < T_{op} < T_{max}$	51			
$A_{vd}$	Large signal voltage gain	$R_L = 10\text{ k}\Omega$ , $V_{out} = 0.5\text{ V to }1.3\text{ V}$	78	95		dB
		$T_{min} < T_{op} < T_{max}$	73			
$V_{OH}$	High level output voltage ( $V_{OH} = V_{CC} - V_{out}$ )	$R_L = 10\text{ k}\Omega$ $T_{min} < T_{op} < T_{max}$		5	35 50	mV
$V_{OL}$	Low level output voltage	$R_L = 10\text{ k}\Omega$ $T_{min} < T_{op} < T_{max}$		4	35 50	
$I_{out}$	Isink	$V_{out} = 1.8\text{ V}$	6	12		mA
		$T_{min} < T_{op} < T_{max}$	4			
	Isource	$V_{out} = 0\text{ V}$	6	10		
		$T_{min} < T_{op} < T_{max}$	4			
$I_{CC}$	Supply current (per operator)	No load, $V_{out} = V_{CC}/2$		25	31	$\mu\text{A}$
		$T_{min} < T_{op} < T_{max}$			33	
<b>AC performance</b>						
GBP	Gain bandwidth product	$R_L = 10\text{ k}\Omega$ , $C_L = 100\text{ pF}$ , $f = 100\text{ kHz}$	275	340		kHz
$F_u$	Unity gain frequency			280		
$\phi_m$	Phase margin	$R_L = 10\text{ k}\Omega$ , $C_L = 100\text{ pF}$ ,		41		Degrees
$G_m$	Gain margin			8		dB
SR	Slew rate	$R_L = 10\text{ k}\Omega$ , $C_L = 100\text{ pF}$ , $A_v = 1$	0.1	0.155		$\text{V}/\mu\text{s}$

1. Guaranteed by design.

**Table 5. Shutdown characteristics  $V_{CC} = 1.8\text{ V}$  (TSV623, TSV625)**

Symbol	Parameter	Conditions	Min.	Typ.	Max.	Unit
<b>DC performance</b>						
$I_{CC}$	Supply current in shutdown mode (all operators)	$\overline{\text{SHDN}} = V_{CC-}$		2.5	50	nA
		$T_{\min} < T_{op} < 85\text{ }^{\circ}\text{C}$			200	
		$T_{\min} < T_{op} < 125\text{ }^{\circ}\text{C}$				1.5
$t_{on}$	Amplifier turn-on time	$R_L = 5\text{ k}$ , $V_{out} = (V_{CC-}) \text{ to } (V_{CC-}) + 0.2\text{ V}$		200		ns
$t_{off}$	Amplifier turn-off time	$R_L = 2\text{ k}$ , $V_{out} = (V_{CC+}) - 0.5\text{ V}$ to $(V_{CC+}) - 0.7\text{ V}$		20		
$V_{IH}$	$\overline{\text{SHDN}}$ logic high		1.35			V
$V_{IL}$	$\overline{\text{SHDN}}$ logic low				0.6	
$I_{IH}$	$\overline{\text{SHDN}}$ current high	$\overline{\text{SHDN}} = V_{CC+}$		10		pA
$I_{IL}$	$\overline{\text{SHDN}}$ current low	$\overline{\text{SHDN}} = V_{CC-}$		10		
$I_{OLeak}$	Output leakage in shutdown mode	$\overline{\text{SHDN}} = V_{CC-}$		50		nA
		$T_{\min} < T_{op} < 125\text{ }^{\circ}\text{C}$		1		

**Table 6. Electrical characteristics at  $V_{CC+} = 3.3\text{ V}$  with  $V_{CC-} = 0\text{ V}$ ,  $V_{icm} = V_{CC}/2$ ,  $T_{amb} = 25\text{ }^\circ\text{C}$ , and  $R_L$  connected to  $V_{CC}/2$  (unless otherwise specified)**

Symbol	Parameter	Conditions	Min.	Typ.	Max.	Unit
<b>DC performance</b>						
$V_{io}$	Offset voltage	TSV62x TSV62xA TSV623AIST - MiniSO10			4 0.8 1	mV
		TSV62x - $T_{min} < T_{op} < T_{max}$ TSV62xA - $T_{min} < T_{op} < T_{max}$ TSV623AIST - $T_{min} < T_{op} < T_{max}$			6 2 2.2	
$\Delta V_{io}/\Delta T$	Input offset voltage drift			2		$\mu\text{V}/^\circ\text{C}$
$I_{io}$	Input offset current			1	10 <sup>(1)</sup>	pA
		$T_{min} < T_{op} < T_{max}$		1	100	
$I_{ib}$	Input bias current			1	10 <sup>(1)</sup>	
		$T_{min} < T_{op} < T_{max}$		1	100	
CMR	Common mode rejection ratio $20 \log (\Delta V_{ic}/\Delta V_{io})$	0 V to 3.3 V, $V_{out} = 1.65\text{ V}$	57	79		dB
		$T_{min} < T_{op} < T_{max}$	53			
$A_{vd}$	Large signal voltage gain	$R_L = 10\text{ k}\Omega$ , $V_{out} = 0.5\text{ V to } 2.8\text{ V}$	81	98		
		$T_{min} < T_{op} < T_{max}$	76			
$V_{OH}$	High level output voltage ( $V_{OH} = V_{CC} - V_{out}$ )	$R_L = 10\text{ k}\Omega$ $T_{min} < T_{op} < T_{max}$		5	35 50	mV
$V_{OL}$	Low level output voltage	$R_L = 10\text{ k}\Omega$ $T_{min} < T_{op} < T_{max}$		4	35 50	
$I_{out}$	Isink	$V_o = 5\text{ V}$	23	45		mA
		$T_{min} < T_{op} < T_{max}$	20			
	Isource	$V_o = 0\text{ V}$	23	38		
		$T_{min} < T_{op} < T_{max}$	20			
$I_{CC}$	Supply current (per operator)	No load, $V_{out} = 2.5\text{ V}$		26	33	$\mu\text{A}$
		$T_{min} < T_{op} < T_{max}$			35	
<b>AC performance</b>						
GBP	Gain bandwidth product	$R_L = 10\text{ k}\Omega$ , $C_L = 100\text{ pF}$ , $f = 100\text{ kHz}$	310	380		kHz
$F_u$	Unity gain frequency			310		
$\phi_m$	Phase margin	$R_L = 10\text{ k}\Omega$ , $C_L = 100\text{ pF}$		41		Degrees
$G_m$	Gain margin			8		dB
SR	Slew rate	$R_L = 10\text{ k}\Omega$ , $C_L = 100\text{ pF}$ , $A_V = 1$	0.11	0.175		$\text{V}/\mu\text{s}$

1. Guaranteed by design.

**Table 7. Electrical characteristics at  $V_{CC+} = 5\text{ V}$  with  $V_{CC-} = 0\text{ V}$ ,  $V_{icm} = V_{CC}/2$ ,  $T_{amb} = 25\text{ }^\circ\text{C}$ , and  $R_L$  connected to  $V_{CC}/2$  (unless otherwise specified)**

Symbol	Parameter	Conditions	Min.	Typ.	Max.	Unit
<b>DC performance</b>						
$V_{io}$	Offset voltage	TSV62x TSV62xA TSV623AIST - MiniSO10			4 0.8 1	mV
		TSV62x - $T_{min} < T_{op} < T_{max}$ TSV62xA - $T_{min} < T_{op} < T_{max}$ TSV62xA - $T_{min} < T_{op} < T_{max}$			6 2 2.2	
$\Delta V_{io}/\Delta T$	Input offset voltage drift			2		$\mu\text{V}/^\circ\text{C}$
$I_{io}$	Input offset current			1	$10^{(1)}$	pA
		$T_{min} < T_{op} < T_{max}$		1	100	
$I_{ib}$	Input bias current			1	$10^{(1)}$	pA
		$T_{min} < T_{op} < T_{max}$		1	100	
CMR	Common mode rejection ratio $20 \log (\Delta V_{ic}/\Delta V_{io})$	$0\text{ V to }5\text{ V}$ , $V_{out} = 2.5\text{ V}$	60	80		dB
		$T_{min} < T_{op} < T_{max}$	55			
$A_{vd}$	Large signal voltage gain	$R_L = 10\text{ k}\Omega$ , $V_{out} = 0.5\text{ V to }4.5\text{ V}$	85	98		dB
		$T_{min} < T_{op} < T_{max}$	80			
SVR	Supply voltage rejection ratio $20 \log (\Delta V_{CC}/\Delta V_{io})$	$V_{CC} = 1.8\text{ to }5\text{ V}$	75	102		dB
		$T_{min} < T_{op} < T_{max}$	73			
EMIRR	EMI rejection ratio EMIRR = $-20 \log (V_{RFpeak}/\Delta V_{io})$	$V_{RF} = 100\text{ mV}_{rms}$ , $f = 400\text{ MHz}$		61		dB
		$V_{RF} = 100\text{ mV}_{rms}$ , $f = 900\text{ MHz}$		85		
		$V_{RF} = 100\text{ mV}_{rms}$ , $f = 1800\text{ MHz}$		92		
		$V_{RF} = 100\text{ mV}_{rms}$ , $f = 2400\text{ MHz}$		83		
$V_{OH}$	High level output voltage ( $V_{OH} = V_{CC} - V_{out}$ )	$R_L = 10\text{ k}\Omega$		7	35	mV
		$T_{min} < T_{op} < T_{max}$			50	
$V_{OL}$	Low level output voltage	$R_L = 10\text{ k}\Omega$		6	35	mV
		$T_{min} < T_{op} < T_{max}$			50	
$I_{out}$	$I_{sink}$	$V_o = 5\text{ V}$	40	69		mA
		$T_{min} < T_{op} < T_{max}$	35			
	$I_{source}$	$V_o = 0\text{ V}$	40	74		
		$T_{min} < T_{op} < T_{max}$	35			
$I_{CC}$	Supply current (per operator)	No load, $V_{out} = 2.5\text{ V}$		29	36	$\mu\text{A}$
		$T_{min} < T_{op} < T_{max}$			38	
<b>AC performance</b>						
GBP	Gain bandwidth product	$R_L = 10\text{ k}\Omega$ , $C_L = 100\text{ pF}$ , $f = 100\text{ kHz}$	350	420		kHz
$F_u$	Unity gain frequency	$R_L = 10\text{ k}\Omega$ , $C_L = 100\text{ pF}$		360		

**Table 7. Electrical characteristics at  $V_{CC+} = 5\text{ V}$  with  $V_{CC-} = 0\text{ V}$ ,  $V_{icm} = V_{CC}/2$ ,  $T_{amb} = 25\text{ °C}$ , and  $R_L$  connected to  $V_{CC}/2$  (unless otherwise specified) (continued)**

Symbol	Parameter	Conditions	Min.	Typ.	Max.	Unit
$\phi_m$	Phase margin	$R_L = 10\text{ k}\Omega$ , $C_L = 100\text{ pF}$		40		Degrees
$G_m$	Gain margin			8		dB
SR	Slew rate	$R_L = 10\text{ k}\Omega$ , $C_L = 100\text{ pF}$ , $A_V = 1$	0.12	0.19		V/ $\mu$ s
$e_n$	Equivalent input noise voltage	$f = 1\text{ kHz}$		77		$\frac{nV}{\sqrt{Hz}}$
THD+ $e_n$	Total harmonic distortion + noise	$A_V = 1$ , $f = 1\text{ kHz}$ , $R_L = 100\text{ k}\Omega$ , $V_{icm} = V_{CC}/2$ , $V_{out} = 2\text{ Vpp}$		0.002		%

1. Guaranteed by design.

**Table 8. Shutdown characteristics at  $V_{CC} = 5\text{ V}$  (TSV623, TSV625)**

Symbol	Parameter	Conditions	Min.	Typ.	Max.	Unit
<b>DC performance</b>						
$I_{CC}$	Supply current in shutdown mode (all operators)	$\overline{\text{SHDN}} = V_{IL}$		5	50	nA
		$T_{min} < T_{op} < 85\text{ °C}$			200	
		$T_{min} < T_{op} < 125\text{ °C}$				1.5
$t_{on}$	Amplifier turn-on time	$R_L = 5\text{ k}\Omega$ , $V_{out} = (V_{CC-})$ to $(V_{CC-}) + 0.2\text{ V}$		200		ns
$t_{off}$	Amplifier turn-off time	$R_L = 5\text{ k}\Omega$ , $V_{out} = (V_{CC+}) - 0.5\text{ V}$ to $(V_{CC+}) - 0.7\text{ V}$		20		
$V_{IH}$	$\overline{\text{SHDN}}$ logic high		2			V
$V_{IL}$	$\overline{\text{SHDN}}$ logic low				0.8	
$I_{IH}$	$\overline{\text{SHDN}}$ current high	$\overline{\text{SHDN}} = V_{CC+}$		10		pA
$I_{IL}$	$\overline{\text{SHDN}}$ current low	$\overline{\text{SHDN}} = V_{CC-}$		10		
$I_{OLeak}$	Output leakage in shutdown mode	$\overline{\text{SHDN}} = V_{CC-}$		50		
		$T_{min} < T_{op} < 125\text{ °C}$		1		nA

**Figure 2. Supply current vs. supply voltage at  $V_{icm} = V_{CC}/2$**

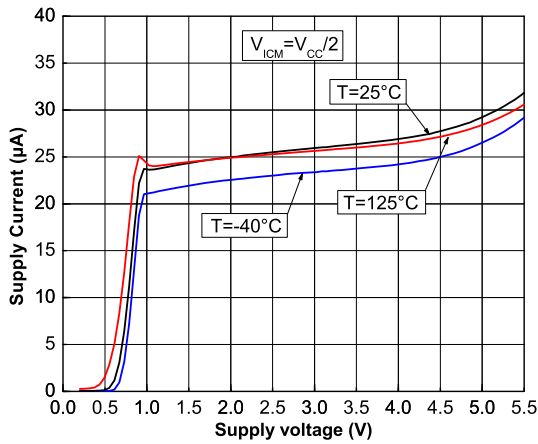

**Figure 3. Output current vs. output voltage at  $V_{CC} = 1.5 V$**

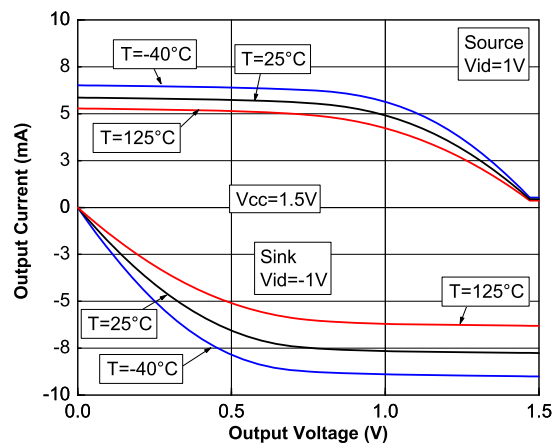

**Figure 4. Output current vs. output voltage at  $V_{CC} = 5 V$**

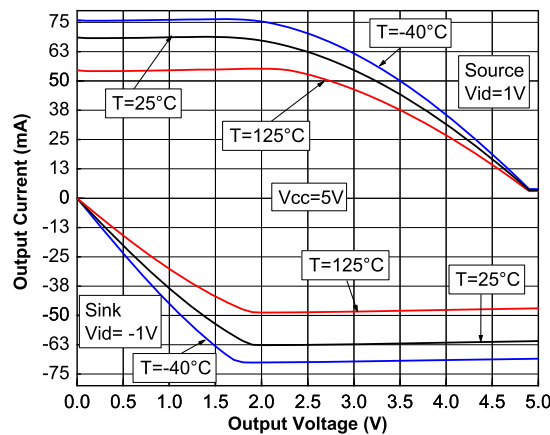

**Figure 5. Voltage gain and phase vs. frequency at  $V_{CC} = 1.5 V$**

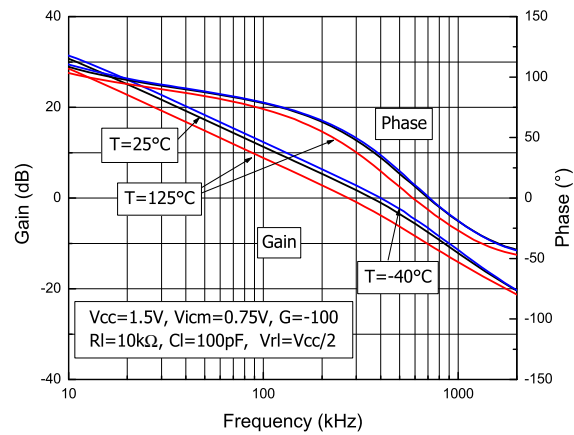

**Figure 6. Voltage gain and phase vs. frequency at  $V_{CC} = 5 V$**

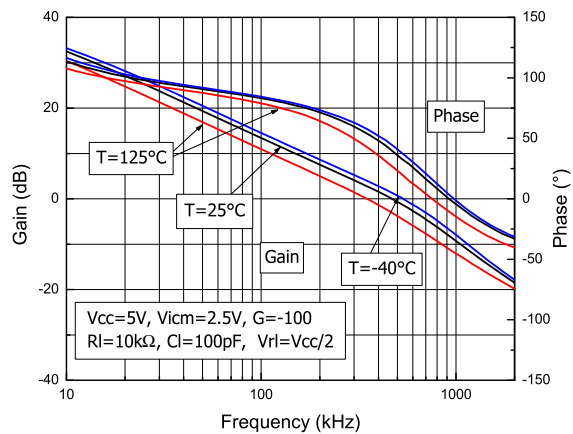

**Figure 7. Phase margin vs. output current at  $V_{CC} = 1.5 V$  and  $V_{CC} = 5 V$**

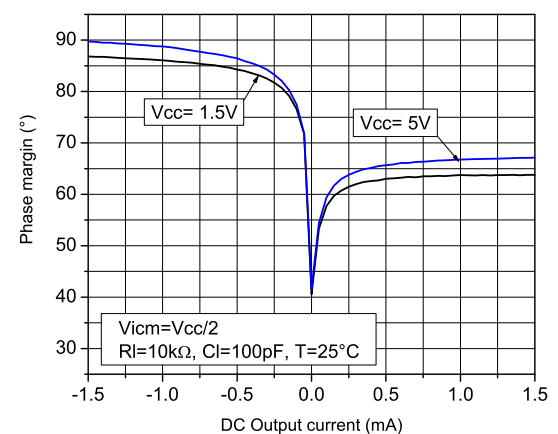

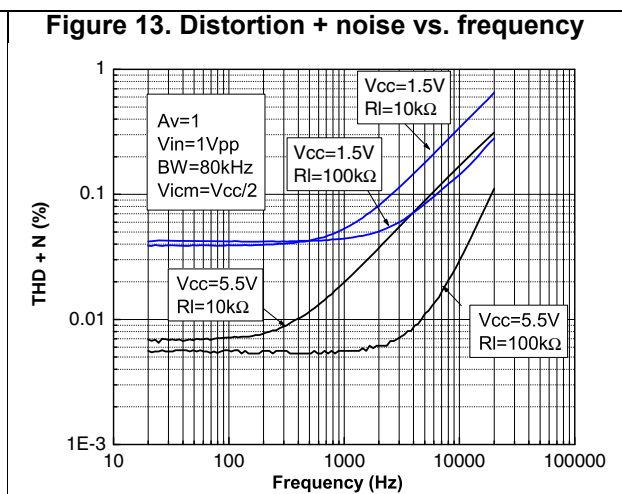
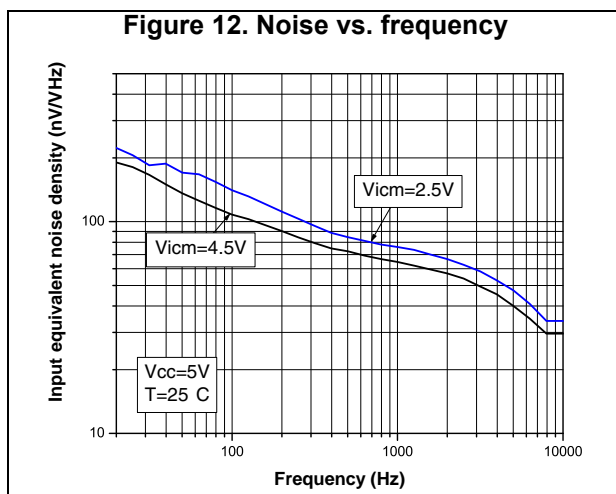
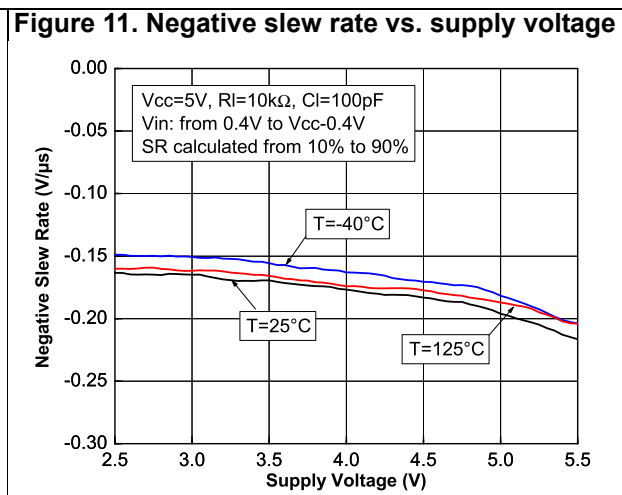
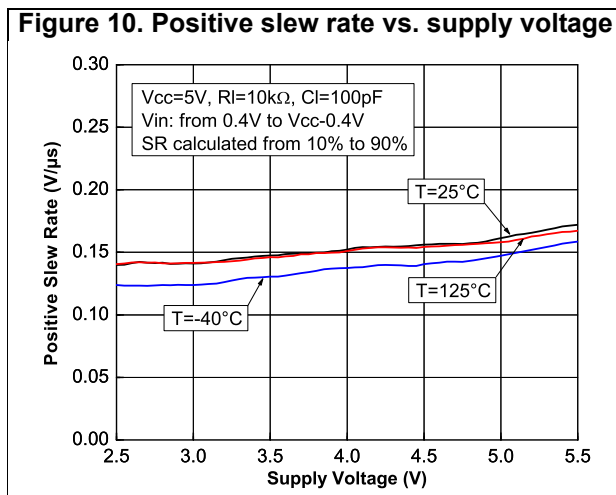
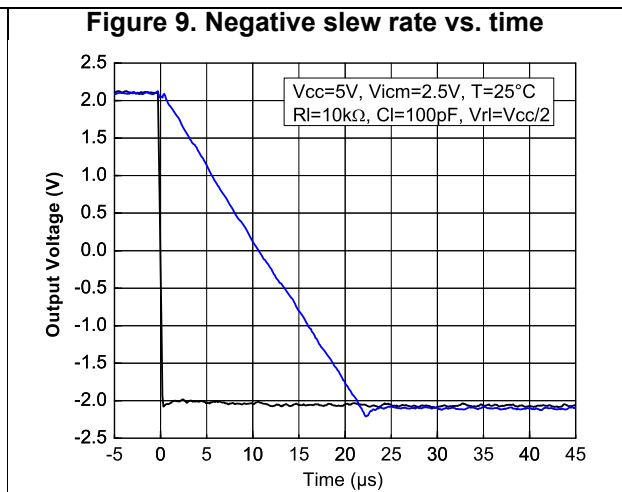
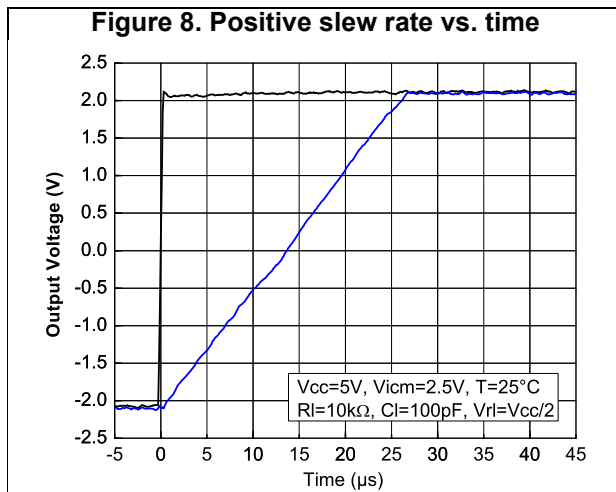

Figure 14. Distortion + noise vs. output voltage

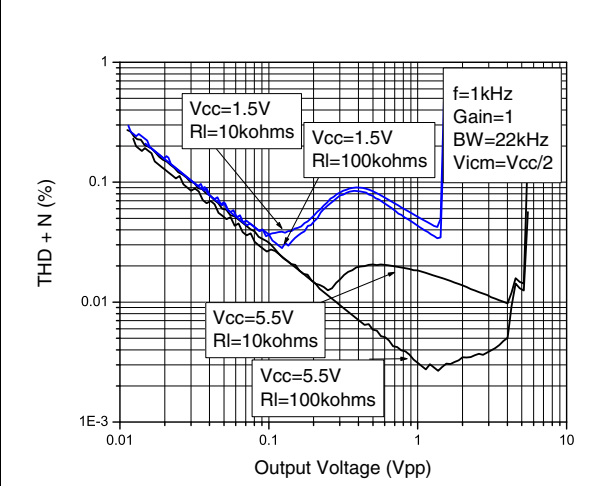
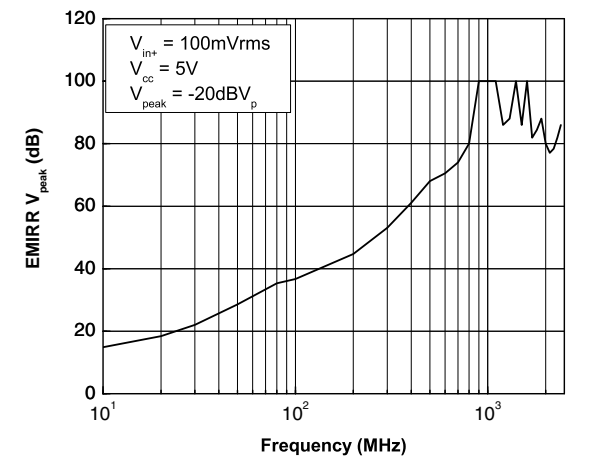

Figure 15. EMIRR vs. frequency at V<sub>CC</sub> = 5 V, T = 25 °C



## 4 Application information

### 4.1 Operating voltages

The TSV62x/TSV62xA can operate from 1.5 to 5.5 V. Parameters are fully specified for 1.8-, 3.3-, and 5-V power supplies. However, the parameters are very stable in the full  $V_{CC}$  range and several characterization curves show the TSV62x/TSV62xA characteristics at 1.5 V. Additionally, the main specifications are guaranteed in extended temperature ranges from -40 °C to 125 °C.

### 4.2 Rail-to-rail input

The TSV62x/TSV62xA is built with two complementary PMOS and NMOS input differential pairs. The device has a rail-to-rail input, and the input common mode range is extended from  $(V_{CC-}) - 0.1$  V to  $(V_{CC+}) + 0.1$  V. The transition between the two pairs appears at  $(V_{CC+}) - 0.7$  V. In the transition region, the performance of CMRR, PSRR,  $V_{io}$  (Figure 16 and Figure 17) and THD is slightly degraded.

**Figure 16. Input offset voltage vs input common mode at  $V_{CC} = 1.5$  V**

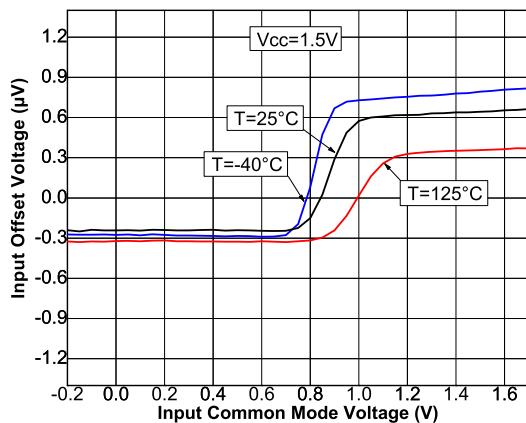

**Figure 17. Input offset voltage vs input common mode at  $V_{CC} = 5$  V**

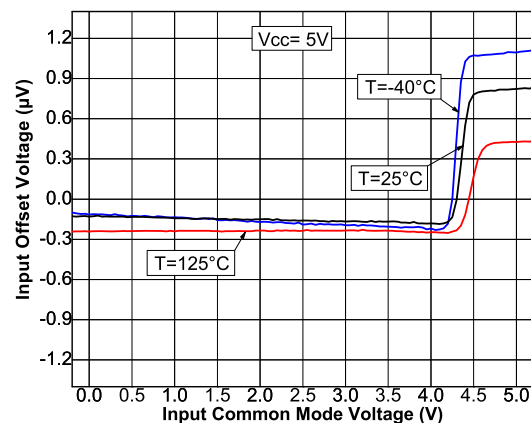

The devices are guaranteed without phase reversal.

### 4.3 Rail-to-rail output

The operational amplifier's output level can go close to the rails: 35 mV maximum above and below the rail when connected to a 10 k $\Omega$  resistive load to  $V_{CC}/2$ .

### 4.4 Optimization of DC and AC parameters

These operational amplifiers use an innovative approach to reduce the spread of the main DC and AC parameters. An internal adjustment achieves a very narrow spread of current consumption (29  $\mu\text{A}$  typical, min/max at  $\pm 17\%$ ). Parameters linked to the current consumption value, such as GBP, SR and AVd benefit from this narrow dispersion. All parts present a similar speed and the same behavior in terms of stability. In addition, the minimum values of GBP and SR are guaranteed (GBP = 350 kHz min, SR = 0.12 V/ $\mu\text{s}$  min).

### 4.5 Shutdown function (TSV623, TSV625)

The operational amplifier is enabled when the  $\overline{\text{SHDN}}$  pin is pulled high. To disable the amplifier, the  $\overline{\text{SHDN}}$  must be pulled down to  $V_{\text{CC-}}$ . When in shutdown mode, the amplifier output is in a high impedance state. The  $\overline{\text{SHDN}}$  pin must never be left floating but tied to  $V_{\text{CC+}}$  or  $V_{\text{CC-}}$ . The turn-on and turn-off times are calculated for an output variation of  $\pm 200$  mV (Figure 18 and Figure 19 show the test configurations). Figure 20 and Figure 21 show output voltage behavior when the  $\overline{\text{SHDN}}$  pin is toggled.

Figure 18. Test configuration for turn-on time (Vout pulled down)

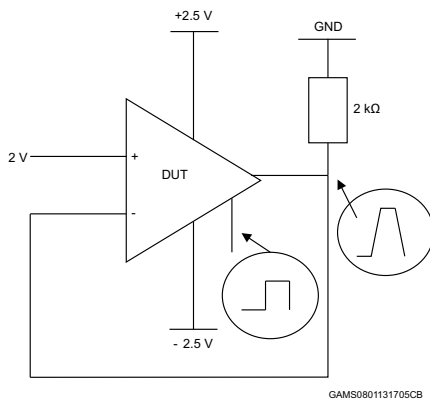

Figure 19. Test configuration for turn-off time (Vout pulled down)

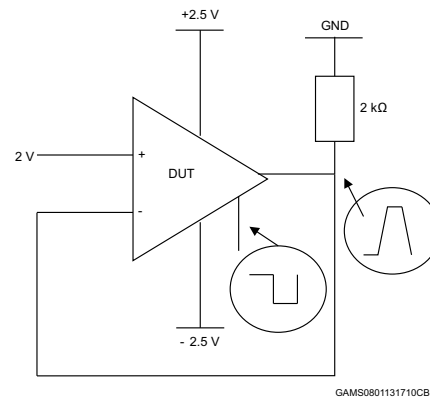

Figure 20. Turn-on time,  $V_{\text{CC}} = \pm 2.5$  V, Vout pulled down,  $T = 25$  °C

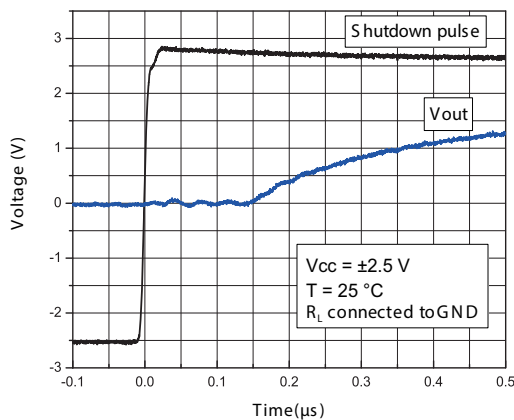
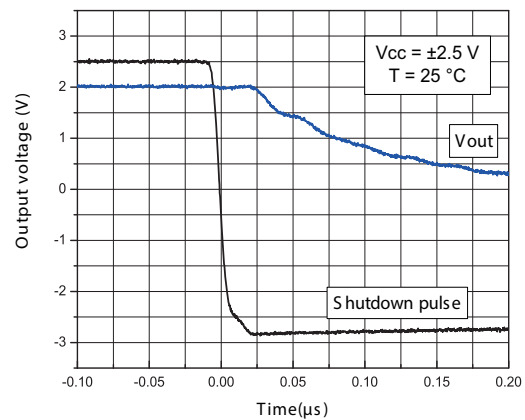

Figure 21. Turn-off time,  $V_{\text{CC}} = \pm 2.5$  V, Vout pulled down,  $T = 25$  °C



## 4.6 Driving resistive and capacitive loads

These products are micro-power, low-voltage operational amplifiers optimized to drive rather large resistive loads, above 5 k $\Omega$ . For lower resistive loads, the THD level may significantly increase.

In a *follower* configuration, these operational amplifiers can drive capacitive loads up to 100 pF with no oscillations. When driving larger capacitive loads, adding a small resistor in series at the output can improve the stability of the device (see [Figure 22](#) for recommended in-series resistor values). Once the value of the in-series resistor has been selected, the stability of the circuit should be tested on bench and simulated with the simulation model.

**Figure 22. In-series resistor vs. capacitive load**

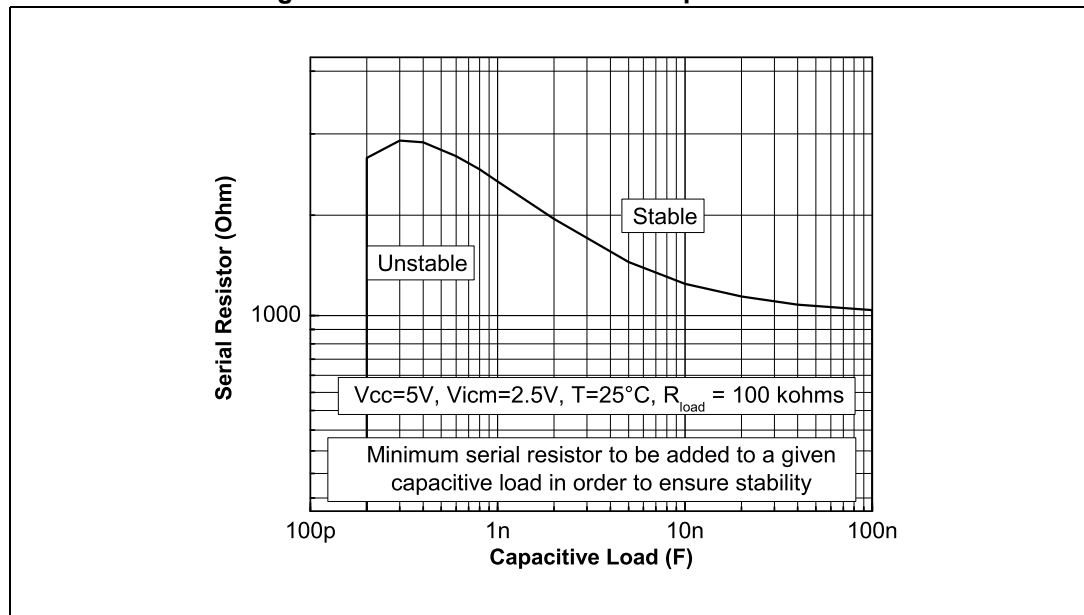

## 4.7 PCB layouts

For correct operation, it is advised to add 10 nF decoupling capacitors as close as possible to the power supply pins.

## 4.8 Macromodel

Two accurate macromodels (with or without shutdown feature) of TSV62x/TSV62xA are available on STMicroelectronics' web site at [www.st.com](http://www.st.com). This model is a trade-off between accuracy and complexity (that is, time simulation) of the TSV62x/TSV62xA operational amplifiers. It emulates the nominal performances of a typical device within the specified operating conditions mentioned in the datasheet. It helps to validate a design approach and to select the right operational amplifier, *but it does not replace on-board measurements*.

## 5 Package information

In order to meet environmental requirements, ST offers these devices in different grades of ECOPACK<sup>®</sup> packages, depending on their level of environmental compliance. ECOPACK<sup>®</sup> specifications, grade definitions and product status are available at: [www.st.com](http://www.st.com). ECOPACK<sup>®</sup> is an ST trademark.

### 5.1 SO8 package information

Figure 23. SO8 package outline

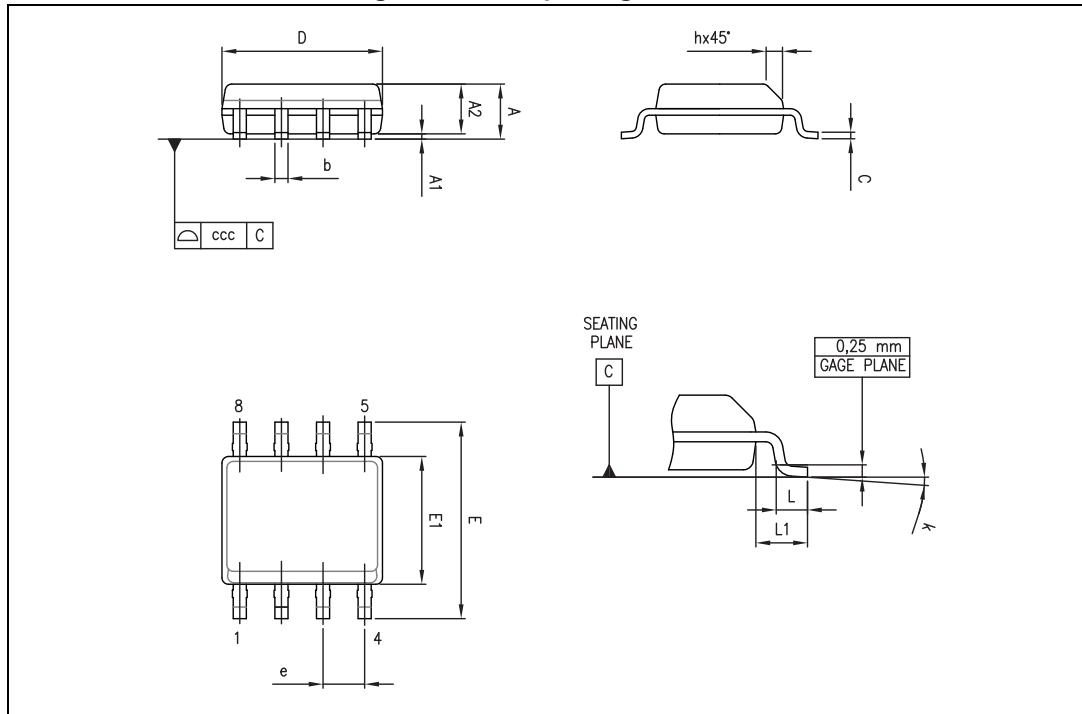

Table 9. SO8 mechanical data

Ref.	Dimensions					
	Millimeters			Inches		
	Min.	Typ.	Max.	Min.	Typ.	Max.
A			1.75			0.069
A1	0.10		0.25	0.004		0.010
A2	1.25			0.049		
b	0.28		0.48	0.011		0.019
c	0.17		0.23	0.007		0.010
D	4.80	4.90	5.00	0.189	0.193	0.197
E	5.80	6.00	6.20	0.228	0.236	0.244
E1	3.80	3.90	4.00	0.150	0.154	0.157
e		1.27			0.050	
h	0.25		0.50	0.010		0.020
L	0.40		1.27	0.016		0.050
L1		1.04			0.040	
k	0		8°	1°		8°
ccc			0.10			0.004

## 5.2 MiniSO8 package information

Figure 24. MiniSO8 package outline

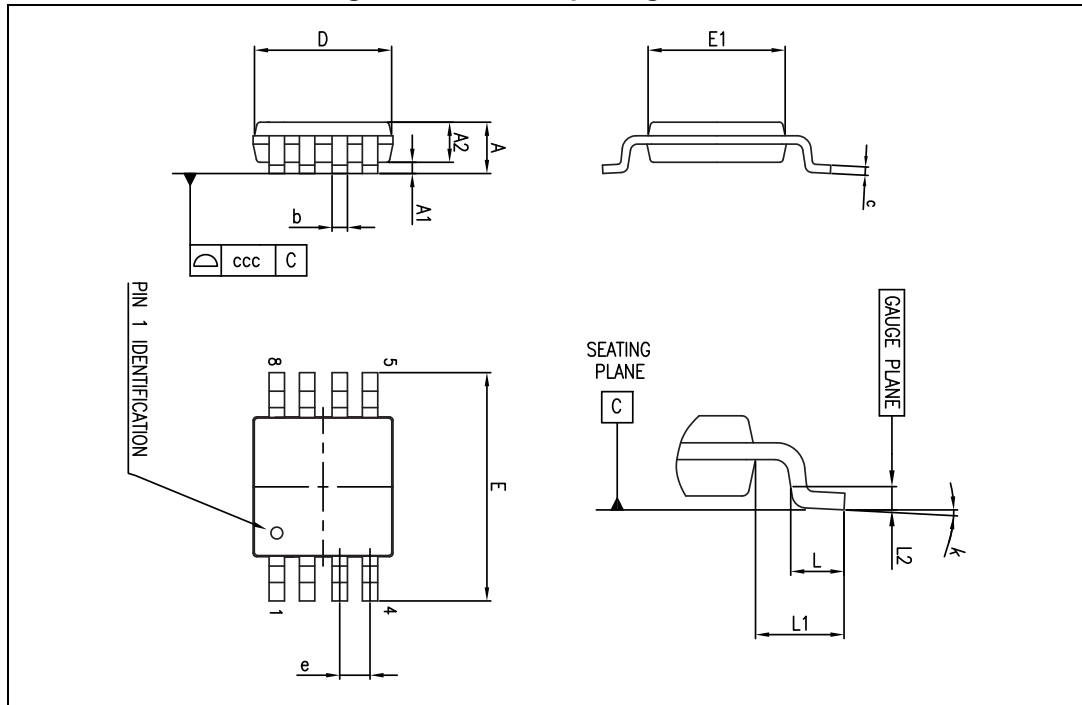

Table 10. MiniSO8 mechanical data

Ref.	Dimensions					
	Millimeters			Inches		
	Min.	Typ.	Max.	Min.	Typ.	Max.
A			1.1			0.043
A1	0		0.15	0		0.006
A2	0.75	0.85	0.95	0.030	0.033	0.037
b	0.22		0.40	0.009		0.016
c	0.08		0.23	0.003		0.009
D	2.80	3.00	3.20	0.11	0.118	0.126
E	4.65	4.90	5.15	0.183	0.193	0.203
E1	2.80	3.00	3.10	0.11	0.118	0.122
e		0.65			0.026	
L	0.40	0.60	0.80	0.016	0.024	0.031
L1		0.95			0.037	
L2		0.25			0.010	
k	0°		8°	0°		8°
ccc			0.10			0.004

### 5.3 MiniSO10 package information

Figure 25. MiniSO10 package outline

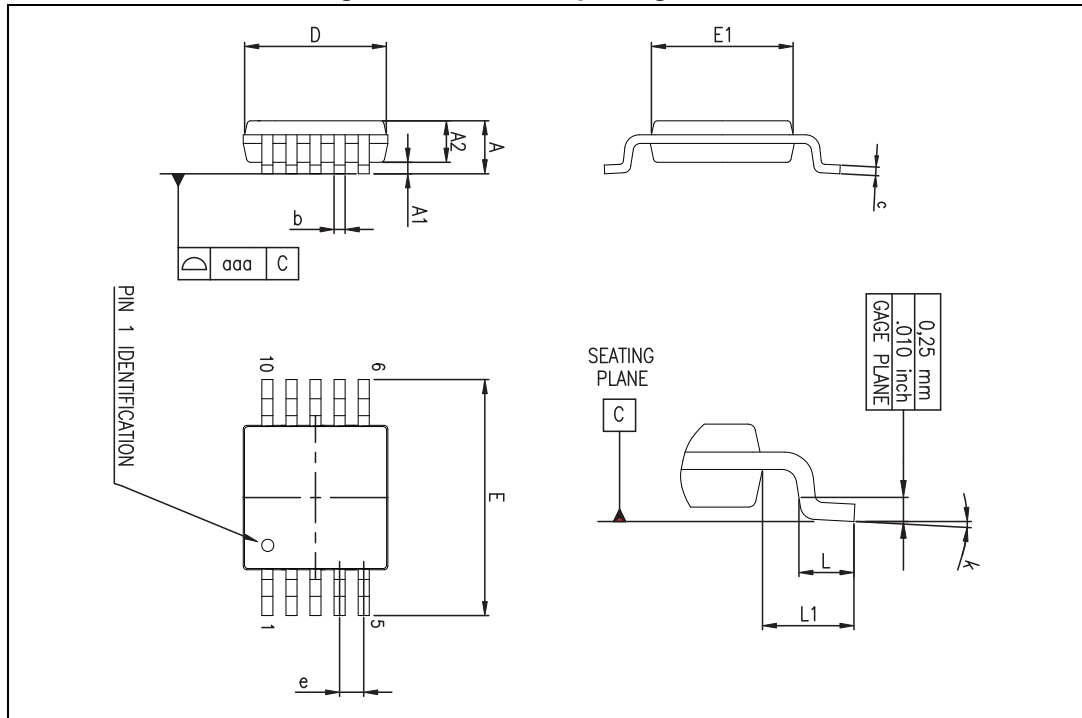

Table 11. MiniSO10 mechanical data

Ref.	Dimensions					
	Millimeters			Inches		
	Min.	Typ.	Max.	Min.	Typ.	Max.
A			1.10			0.043
A1	0.05	0.10	0.15	0.002	0.004	0.006
A2	0.78	0.86	0.94	0.031	0.034	0.037
b	0.25	0.33	0.40	0.010	0.013	0.016
c	0.15	0.23	0.30	0.006	0.009	0.012
D	2.90	3.00	3.10	0.114	0.118	0.122
E	4.75	4.90	5.05	0.187	0.193	0.199
E1	2.90	3.00	3.10	0.114	0.118	0.122
e		0.50			0.020	
L	0.40	0.55	0.70	0.016	0.022	0.028
L1		0.95			0.037	
k	0°	3°	6°	0°	3°	6°
aaa			0.10			0.004

### 5.4 TSSOP14 package information

Figure 26. TSSOP14 package outline

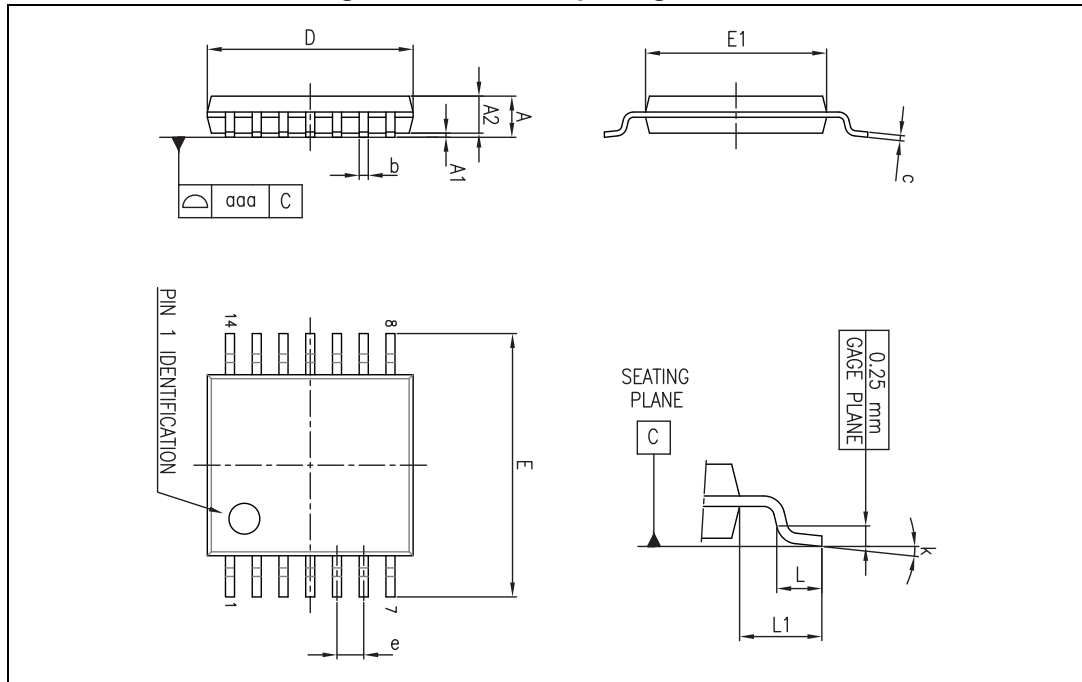

Table 12. TSSOP14 mechanical data

Ref.	Dimensions					
	Millimeters			Inches		
	Min.	Typ.	Max.	Min.	Typ.	Max.
A			1.20			0.047
A1	0.05	0.10	0.15	0.002	0.004	0.006
A2	0.80	1.00	1.05	0.031	0.039	0.041
b	0.19		0.30	0.007		0.012
c	0.09		0.20	0.004		0.0089
D	4.90	5.00	5.10	0.193	0.197	0.201
E	6.20	6.40	6.60	0.244	0.252	0.260
E1	4.30	4.40	4.50	0.169	0.173	0.176
e		0.65			0.0256	
L	0.45	0.60	0.75	0.018	0.024	0.030
L1		1.00			0.039	
k	0°		8°	0°		8°
aaa			0.10			0.004

### 5.5 TSSOP16 package information

Figure 27. TSSOP16 package outline

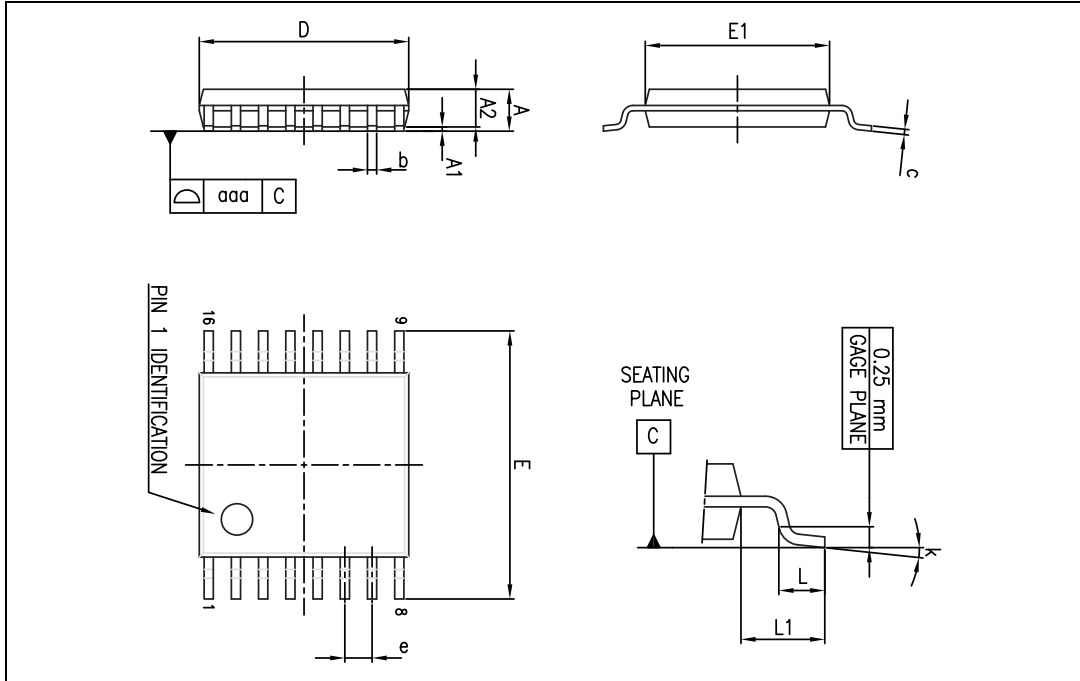

Table 13. TSSOP16 mechanical data

Ref.	Dimensions					
	Millimeters			Inches		
	Min.	Typ.	Max.	Min.	Typ.	Max.
A			1.20			0.047
A1	0.05		0.15	0.002		0.006
A2	0.80	1.00	1.05	0.031	0.039	0.041
b	0.19		0.30	0.007		0.012
c	0.09		0.20	0.004		0.008
D	4.90	5.00	5.10	0.193	0.197	0.201
E	6.20	6.40	6.60	0.244	0.252	0.260
E1	4.30	4.40	4.50	0.169	0.173	0.177
e		0.65			0.0256	
k	0°		8°	0°		8°
L	0.45	0.60	0.75	0.018	0.024	0.030
L1		1.00			0.039	
aaa			0.10			0.004

## 6 Ordering information

Table 14. Order codes

Order codes	Temperature range	Package	Packing	Marking
TSV622IDT	-40 °C to 125 °C	SO8	Tape and reel	TSV622
TSV622AIDT				TSV622A
TSV622IST		MiniSO8		K107
TSV622AIST				K143
TSV623IST		MiniSO10		K114
TSV623AIST				K144
TSV624IPT		TSSOP14		TSV624
TSV624AIPT				TSV624A
TSV625IPT		TSSOP16		TSV625
TSV625AIPT				TSV625A

## 7 Revision history

**Table 15. Document revision history**

Date	Revision	Changes
25-May-2009	1	Initial release.
15-Jun-2009	2	Corrected pin connection diagram in Figure 1.
24-Aug-2009	3	Added root part numbers (TSv62xA) and Table 1: Device summary on cover page. Added order code TSV622AILT in Table 15: Order codes.
22-Oct-2009	4	Corrected error in Table 15: Order codes: TSV625 offered in TSSOP16.
09-Jan-2013	5	Updated Features. Updated Figure 1. Table 4, Table 6, and Table 7: replaced $DV_{iO}$ with $\Delta V_{iO}/\Delta T$ . Section 4.5: Shutdown function (TSV623, TSV625): added explanation of Figure 20 and Figure 21; replaced Figure 18 and Figure 19; updated Figure 20 and Figure 21. Corrected error in Table 15: Order codes: the marking for the order code TSV622AILT is K143.
23-May-2017	6	Changed part number layout on cover page Removed package SOT23-5 <a href="#">Table 4</a> , <a href="#">Table 6</a> , and <a href="#">Table 7</a> : updated $V_{OH}$ parameter information and changed min. values to max. values. <a href="#">Table 14: Order codes</a> : removed obsolete order codes: TSV622ILT, TSV622AILT, TSV622ID, TSV622AID

**IMPORTANT NOTICE – PLEASE READ CAREFULLY**

STMicroelectronics NV and its subsidiaries (“ST”) reserve the right to make changes, corrections, enhancements, modifications, and improvements to ST products and/or to this document at any time without notice. Purchasers should obtain the latest relevant information on ST products before placing orders. ST products are sold pursuant to ST’s terms and conditions of sale in place at the time of order acknowledgement.

Purchasers are solely responsible for the choice, selection, and use of ST products and ST assumes no liability for application assistance or the design of Purchasers’ products.

No license, express or implied, to any intellectual property right is granted by ST herein.

Resale of ST products with provisions different from the information set forth herein shall void any warranty granted by ST for such product.



ST and the ST logo are trademarks of ST. All other product or service names are the property of their respective owners.

Information in this document supersedes and replaces information previously supplied in any prior versions of this document.

© 2017 STMicroelectronics – All rights reserved

## Looking for pricing, stock, or lifecycle information?

Click below to explore more details on WIN SOURCE:

-  [View TSV624IPT](#) on WIN SOURCE
-  [STMicroelectronics](#) Information

## Optimize Your Supply Chain with WIN SOURCE Solutions

-  Global Sourcing Solution
-  Obsolete Management
-  Cost Control Management
-  Shortage Management
-  Alternative Solution
-  Excess Inventory Management