



# MMC, SD CARD, Memory Stick™ VOLTAGE-TRANSLATION TRANSCIEVER WITH ESD PROTECTION AND EMI FILTERING

 Check for Samples: [TXS0206](#)

## FEATURES

- **Level Translator**
  - $V_{CCA}$  and  $V_{CCB}$  Range of 1.1 V to 3.6 V
  - Fast Propagation Delay (4 ns Max When Translating Between 1.8 V and 3 V)
- **Integrated EMI Filtering and ESD Protection Circuitry**
- **ESD Protection Exceeds JESD 22 (A Port)**
  - 2500-V Human-Body Model (A114-B)
  - 250-V Machine Model (A115-A)
  - 1500-V Charged-Device Model (C101)
- **±8-kV Contact Discharge IEC 61000-4-2 ESD (B-port)**

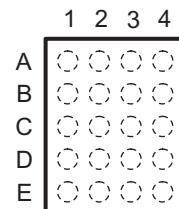
**YFP PACKAGE  
(TOP VIEW)**

**TERMINAL ASSIGNMENTS**

	1	2	3	4
A	DAT2A	$V_{CCA}$	WP	DAT2B
B	DAT3A	CD	$V_{CCB}$	DAT3B
C	CMDA	GND	GND	CMDB
D	DAT0A	CLKA	CLKB	DAT0B
E	DAT1A	CLK-f	EN	DAT1B

## DESCRIPTION/ORDERING INFORMATION

The TXS0206 is a level shifter for interfacing microprocessors with MultiMediaCards (MMCs), secure digital (SD) cards, and Memory Stick™ cards. It includes a high-speed level translator along with ESD protection and EMI filtering circuitry.

The voltage-level translator has two supply voltage pins.  $V_{CCA}$  as well as  $V_{CCB}$  can be operated over the full range of 1.1 V to 3.6 V. The TXS0206 enables system designers to easily interface applications processors or digital basebands to memory cards and SDIO peripherals operating at a different I/O voltage level.

Memory card standards recommend high-ESD protection for devices that connect directly to the external memory card. To meet this need, the TXS0206 incorporates ±8-kV Contact Discharge protection on the card side.

The TXS0206 is offered in a 20-bump wafer chip scale package (WCSP). This package has dimensions of 1.96 mm × 1.56 mm, with a 0.4-mm ball pitch for effective board-space savings. Memory cards are widely used in mobile phones, PDAs, digital cameras, personal media players, camcorders, set-top boxes, etc. Low static power consumption and small package size make the TXS0206 an ideal choice for these applications.

## ORDERING INFORMATION<sup>(1)</sup>

$T_A$	PACKAGE <sup>(2)</sup>		ORDERABLE PART NUMBER	TOP-SIDE MARKING <sup>(3)</sup>
–40°C to 85°C	WCSP – YFP (Pb-free)	Tape and reel	TXS0206YFPR	___3T_

(1) For the most current package and ordering information, see the Package Option Addendum at the end of this document, or see the TI web site at [www.ti.com](http://www.ti.com).

(2) Package drawings, thermal data, and symbolization are available at [www.ti.com/packaging](http://www.ti.com/packaging).

(3) YFP: The actual top-side marking has three preceding characters to denote year, month, and sequence code, and one following character to designate the assembly/test site. Pin 1 identifier indicates solder-bump composition (1 = SnPb, • = Pb-free).



Please be aware that an important notice concerning availability, standard warranty, and use in critical applications of Texas Instruments semiconductor products and disclaimers thereto appears at the end of this data sheet.

All trademarks are the property of their respective owners.

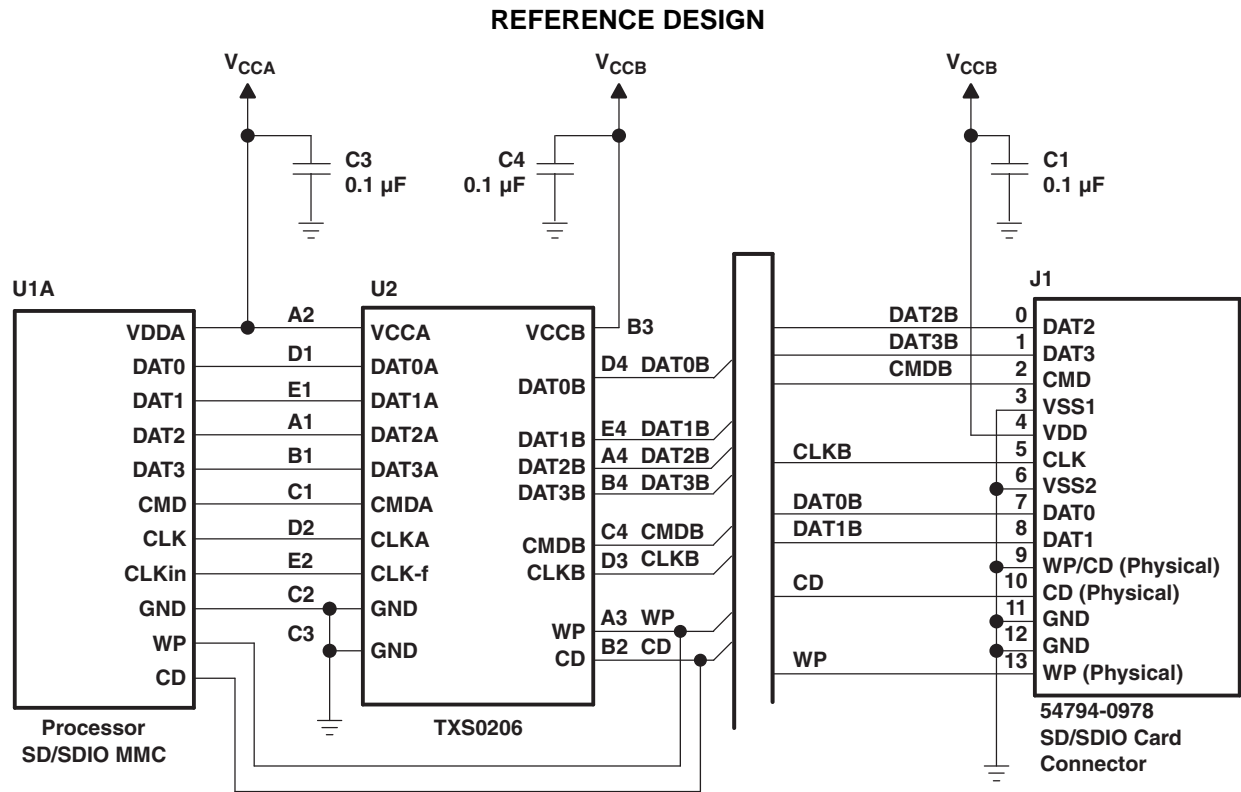

Figure 1. Interfacing With SD/SDIO Card



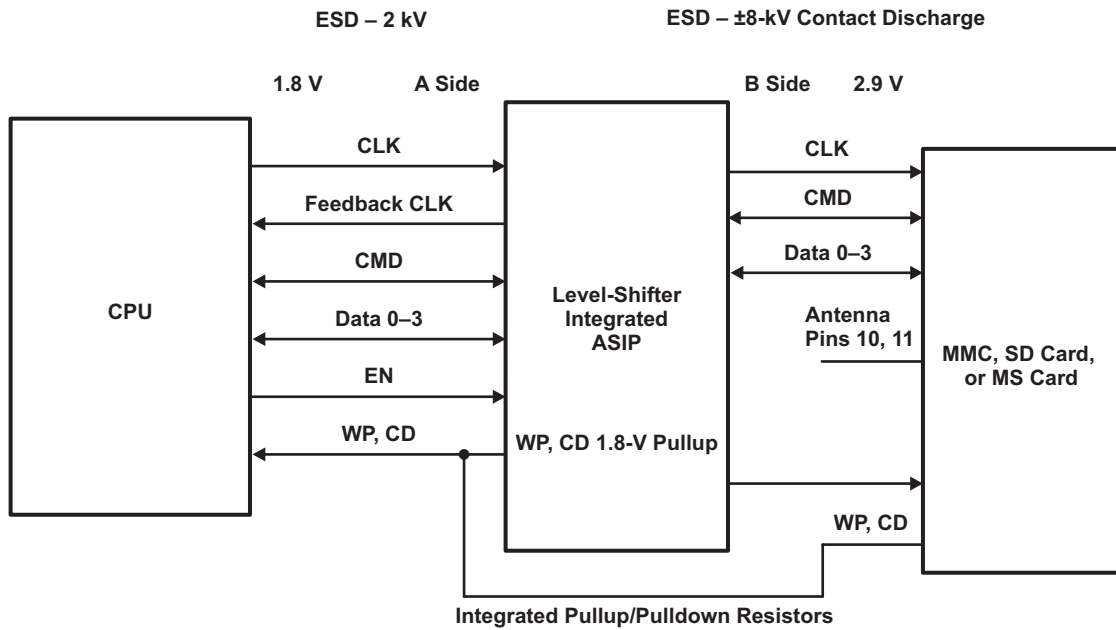

Figure 3. Typical Application Circuit

**LOGIC TABLE**

EN	TRANSLATOR I/Os
L	Disabled, pulled to $V_{CCA}$ , $V_{CCB}$ through 40 k $\Omega$
H	Active

**TERMINAL FUNCTIONS**

TERMINAL		TYPE	DESCRIPTION
NO.	NAME		
A1	DAT2A	I/O	Data bit 2 connected to host. Referenced to $V_{CCA}$ . Includes a 40-k $\Omega$ pullup resistor to $V_{CCA}$ .
A2	$V_{CCA}$	Pwr	A-port supply voltage. $V_{CCA}$ powers all A-port I/Os and control inputs.
A3	WP	O	Connected to write protect on the mechanical connector. The WP pin has an internal 100-k $\Omega$ pullup resistor to $V_{CCA}$ .
A4	DAT2B	I/O	Data bit 2 connected to memory card. Referenced to $V_{CCB}$ . Includes a 40-k $\Omega$ pullup resistor to $V_{CCB}$ .
B1	DAT3A	I/O	Data bit 3 connected to host. Referenced to $V_{CCA}$ . Includes a 40-k $\Omega$ pullup resistor to $V_{CCA}$ .
B2	CD	O	Connected to card detect on the mechanical connector. The CD pin has an internal 100-k $\Omega$ pullup resistor to $V_{CCA}$ .
B3	$V_{CCB}$	Pwr	B-port supply voltage. $V_{CCB}$ powers all B-port I/Os.
B4	DAT3B	I/O	Data bit 3 connected to memory card. Referenced to $V_{CCB}$ . Includes a 40-k $\Omega$ pullup resistor to $V_{CCB}$ .
C1	CMDA	I/O	Command bit connected to host. Referenced to $V_{CCA}$ . Includes a 40-k $\Omega$ pullup resistor to $V_{CCA}$ .
C2, C3	GND		Ground
C4	CMDB	I/O	Command bit connected to memory card. Referenced to $V_{CCB}$ . Includes a 40-k $\Omega$ pullup resistor to $V_{CCB}$ .
D1	DAT0A	I/O	Data bit 0 connected to host. Referenced to $V_{CCA}$ . Includes a 40-k $\Omega$ pullup resistor to $V_{CCA}$ .
D2	CLKA	I	Clock signal connected to host. Referenced to $V_{CCA}$ .
D3	CLKB	O	Clock signal connected to memory card. Referenced to $V_{CCB}$ .
D4	DAT0B	I/O	Data bit 0 connected to memory card. Referenced to $V_{CCB}$ . Includes a 40-k $\Omega$ pullup resistor to $V_{CCB}$ .
E1	DAT1A	I/O	Data bit 1 connected to host. Referenced to $V_{CCA}$ . Includes a 40-k $\Omega$ pullup resistor to $V_{CCA}$ .
E2	CLK-f	O	Clock feedback to host for resynchronizing data to a processor. Leave unconnected if not used.
E3	EN	I	Enable/disable control. Pull EN low to place all outputs in Hi-Z state. Referenced to $V_{CCA}$ .
E4	DAT1B	I/O	Data bit 1 connected to memory card. Referenced to $V_{CCB}$ . Includes a 40-k $\Omega$ pullup resistor to $V_{CCB}$ .

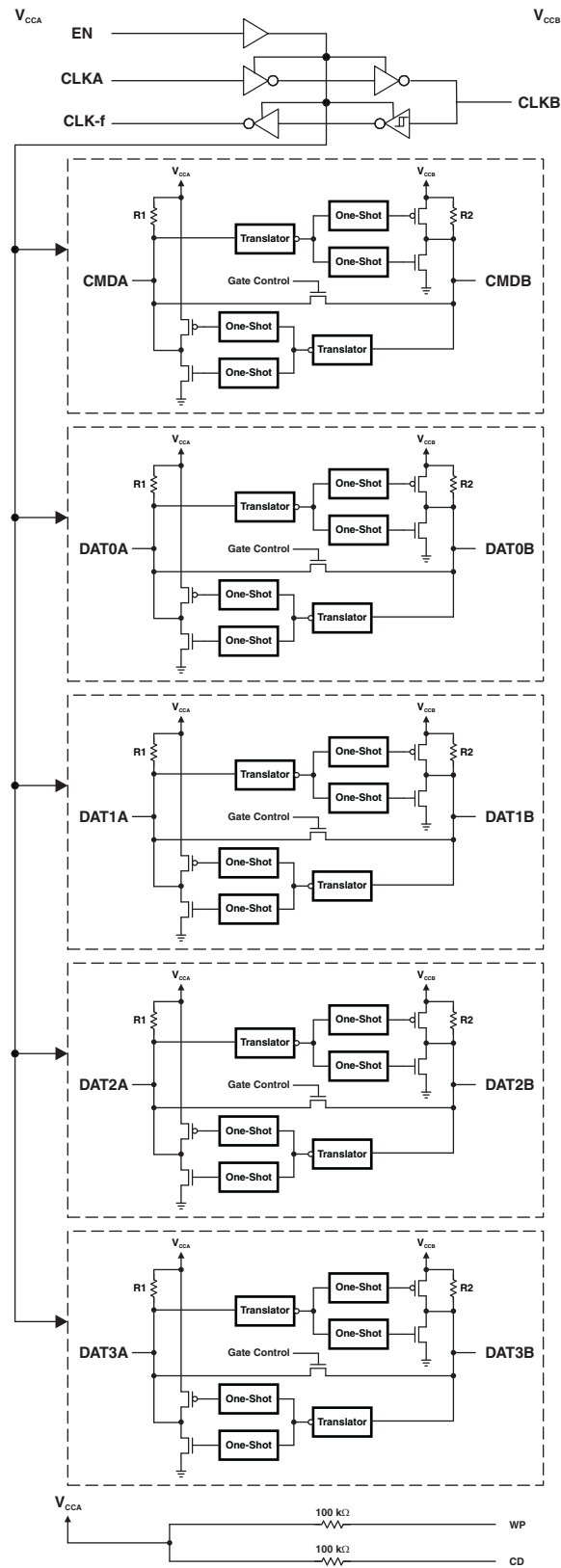
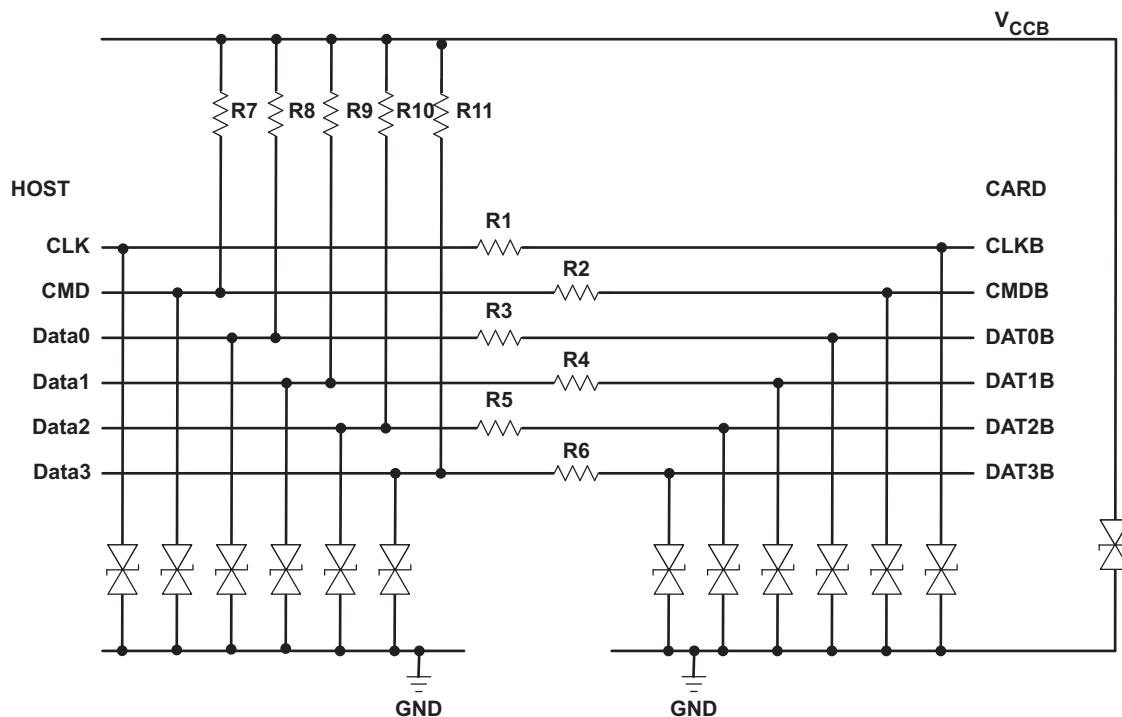

Figure 4. Logic Diagram



RESISTORS	
R1, R2, R3, R4, R5, R6	40 Ω
Tolerance	±20%
R7, R8, R9, R10, R11	40 kΩ
Tolerance	±30%

BIDIRECTIONAL ZENER DIODES	
Vbr min	14 V at 1 mA
Line capacitance	<20 pF

Figure 5. ASIP Block Diagram

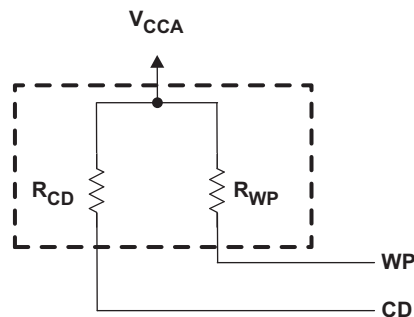

RESISTORS	
R <sub>WP</sub> , R <sub>CD</sub>	100 kΩ
Tolerance	±30%

Figure 6. WP, CD Pullup Resistors

## ABSOLUTE MAXIMUM RATINGS<sup>(1)</sup>

### Level Translator

over operating free-air temperature range (unless otherwise noted)

		MIN	MAX	UNIT	
V <sub>CCA</sub>	Supply voltage range	-0.5	4.6	V	
V <sub>CCB</sub>	Supply voltage range	-0.5	4.6	V	
V <sub>I</sub>	Input voltage range	I/O ports (A port)	-0.5	4.6	V
		I/O ports (B port)	-0.5	4.6	
		Control inputs	-0.5	4.6	
V <sub>O</sub>	Voltage range applied to any output in the high-impedance or power-off state	A port	-0.5	4.6	V
		B port	-0.5	4.6	
V <sub>O</sub>	Voltage range applied to any output in the high or low state	A port	-0.5	4.6	V
		B port	-0.5	4.6	
I <sub>IK</sub>	Input clamp current	V <sub>I</sub> < 0	-50	mA	
I <sub>OK</sub>	Output clamp current	V <sub>O</sub> < 0	-50	mA	
I <sub>O</sub>	Continuous output current		±50	mA	
	Continuous current through V <sub>CCA</sub> or GND		±100	mA	
T <sub>stg</sub>	Storage temperature range	-65	150	°C	

(1) Stresses beyond those listed under "absolute maximum ratings" may cause permanent damage to the device. These are stress ratings only, and functional operation of the device at these or any other conditions beyond those indicated under "recommended operating conditions" is not implied. Exposure to absolute-maximum-rated conditions for extended periods may affect device reliability.

## THERMAL IMPEDANCE RATINGS

		UNIT
θ <sub>JA</sub>	Package thermal impedance <sup>(1)</sup>	117 °C/W

(1) The package thermal impedance is calculated in accordance with JESD 51-7.

**RECOMMENDED OPERATING CONDITIONS<sup>(1)</sup>**  
**Level Translator**

		$V_{CCA}$	$V_{CCB}$	MIN	MAX	UNIT	
$V_{CCA}$	Supply voltage			1.1	3.6	V	
$V_{CCB}$	Supply voltage			1.1	3.6	V	
$V_{IH}$	High-level input voltage	A-Port CMD and DATA I/Os	1.1 V to 1.95 V	1.1 V to 1.95 V	$V_{CCI} - 0.2$	$V_{CCI}$	V
		B-Port CMD and DATA I/Os	1.95 V to 3.6 V	1.95 V to 3.6 V			
		EN and CLKA	1.1 V to 3.6 V	1.1 V to 3.6 V	$V_{CCI} \times 0.65$	$V_{CCI}$	
$V_{IL}$	Low-level input voltage	A-Port CMD and DATA I/Os	1.1 V to 1.95 V	1.1 V to 1.95 V	0	0.15	V
		B-Port CMD and DATA I/Os	1.95 V to 3.6 V	1.95 V to 3.6 V			
		EN and CLKA	1.1 V to 3.6 V	1.1 V to 3.6 V	0	$V_{CCI} \times 0.35$	
$V_O$	Output voltage	Active state		0	$V_{CCO}$	V	
		3-state		0	3.6		
$I_{OH}$	High-level output current (CLK-f output)		1.1 V to 3.6 V	1.1 V to 3.6 V		-100	$\mu$ A
			1.1 V to 1.3 V			-0.5	mA
			1.4 V to 1.6 V			-1	
			1.65 V to 1.95 V			-2	
			2.3 V to 2.7 V			-4	
			3 V to 3.6 V			-8	
$I_{OL}$	Low-level output current (CLK-f output)		1.1 V to 3.6 V	1.1 V to 3.6 V		100	$\mu$ A
			1.1 V to 1.3 V			0.5	mA
			1.4 V to 1.6 V			1	
			1.65 V to 1.95 V			2	
			2.3 V to 2.7 V			4	
			3 V to 3.6 V			8	
$I_{OH}$	High-level output current (CLK output)		1.1 V to 3.6 V			-100	$\mu$ A
			1.1 V to 1.3 V			-0.5	mA
			1.4 V to 1.6 V			-1	
			1.65 V to 1.95 V			-2	
			2.3 V to 2.7 V			-4	
			3 V to 3.6 V			-8	
$I_{OL}$	Low-level output current (CLK output)		1.1 V to 3.6 V			100	$\mu$ A
			1.1 V to 1.3 V			0.5	mA
			1.4 V to 1.6 V			1	
			1.65 V to 1.95 V			2	
			2.3 V to 2.7 V			4	
			3 V to 3.6 V			8	
$\Delta t/\Delta v$	Input transition rise or fall rate				5	ns/V	
$T_A$	Operating free-air temperature			-40	85	$^{\circ}$ C	

(1) All unused data inputs of the device must be held at  $V_{CCI}$  or GND to ensure proper device operation. Refer to the TI application report, *Implications of Slow or Floating CMOS Inputs*, literature number SCBA004.

## ELECTRICAL CHARACTERISTICS

### Level Translator

over recommended operating free-air temperature range (unless otherwise noted)

PARAMETER		TEST CONDITIONS	V <sub>CCA</sub>	V <sub>CCB</sub>	MIN	TYP <sup>(1)</sup>	MAX	UNIT
V <sub>OH</sub>	A port (CLK-f output)	I <sub>OH</sub> = -100 μA	1.1 V to 3.6 V	1.1 V to 3.6 V	V <sub>CCA</sub> * 0.8			V
		I <sub>OH</sub> = -0.5 mA	1.1 V		0.8			
		I <sub>OH</sub> = -1 mA	1.4 V		1.05			
		I <sub>OH</sub> = -2 mA	1.65 V		1.2			
		I <sub>OH</sub> = -4 mA	2.3 V		1.75			
		I <sub>OH</sub> = -8 mA	3 V		2.3			
	A port (DAT and CMD outputs)	I <sub>OH</sub> = -20 μA	1.1 V to 3.6 V		V <sub>CCA</sub> × 0.8			
V <sub>OL</sub>	A port (CLK-f output)	I <sub>OL</sub> = 100 μA	1.1 V to 3.6 V	1.1 V to 3.6 V			V <sub>CCA</sub> × 0.8	V
		I <sub>OL</sub> = 0.5 mA	1.1 V			0.35		
		I <sub>OL</sub> = 1 mA	1.4 V			0.35		
		I <sub>OL</sub> = 2 mA	1.65 V			0.45		
		I <sub>OL</sub> = 4 mA	2.3 V			0.55		
		I <sub>OL</sub> = 8 mA	3 V			0.7		
	A port (DAT and CMD outputs)	I <sub>OL</sub> = 135 μA	1.1 V to 3.6 V			0.4		
		I <sub>OL</sub> = 180 μA				0.4		
		I <sub>OL</sub> = 220 μA				0.4		
		I <sub>OL</sub> = 300 μA				0.4		
		I <sub>OL</sub> = 400 μA				0.55		
V <sub>OH</sub>	B port (CLK output)	I <sub>OH</sub> = -100 μA	1.1 V to 3.6 V	1.1 V to 3.6 V	V <sub>CCA</sub> × 0.8		V	
		I <sub>OH</sub> = -0.5 mA		1.1 V	0.8			
		I <sub>OH</sub> = -1 mA		1.4 V	1.05			
		I <sub>OH</sub> = -2 mA		1.65 V	1.2			
		I <sub>OH</sub> = -4 mA		2.3 V	1.75			
		I <sub>OH</sub> = -8 mA		3 V	2.3			
	B port (DAT output)	I <sub>OH</sub> = -20 μA	1.1 V to 3.6 V	V <sub>CCA</sub> × 0.8				

(1) All typical values are at T<sub>A</sub> = 25°C.

**ELECTRICAL CHARACTERISTICS  
Level Translator (continued)**

over recommended operating free-air temperature range (unless otherwise noted)

PARAMETER		TEST CONDITIONS	V <sub>CCA</sub>	V <sub>CCB</sub>	MIN	TYP <sup>(1)</sup>	MAX	UNIT	
V <sub>OL</sub>	B port	I <sub>OL</sub> = 100 μA	1.1 V to 3.6 V	1.1 V to 3.6 V			V <sub>CCA</sub> × 0.8	V	
		I <sub>OL</sub> = 0.5 mA					1.1 V		0.35
		I <sub>OL</sub> = 1 mA					1.4 V		0.35
		I <sub>OL</sub> = 2 mA					1.65 V		0.45
		I <sub>OL</sub> = 4 mA					2.3 V		0.55
		I <sub>OL</sub> = 8 mA					3 V		0.7
	B port (DAT output)	I <sub>OL</sub> = 135 μA	1.1 V to 3.6 V	1.1 V to 3.6 V			0.4	V	
		I <sub>OL</sub> = 180 μA					1.4 V		0.4
		I <sub>OL</sub> = 220 μA					1.65 V		0.4
		I <sub>OL</sub> = 300 μA					2.3 V		0.4
I <sub>OL</sub> = 400 μA		3 V					0.55		
I <sub>I</sub>	Control inputs	V <sub>I</sub> = V <sub>CCA</sub> or GND		1.1 V to 3.6 V			±1	μA	
I <sub>CCA</sub>		V <sub>I</sub> = V <sub>CCI</sub> or GND, I <sub>O</sub> = 0	1.1 V to 3.6 V	1.1 V to 3.6 V			6	μA	
I <sub>CCB</sub>		V <sub>I</sub> = V <sub>CCI</sub> or GND, I <sub>O</sub> = 0	1.1 V to 3.6 V	1.1 V to 3.6 V			5	μA	
C <sub>io</sub>	A port				5.5	6.5		pF	
	B port				15	17.5			
C <sub>i</sub>	Control inputs	V <sub>I</sub> = V <sub>CCA</sub> or GND			3.5	4.5		pF	
	Clock input				3	4			

**TIMING REQUIREMENTS**

**$V_{CCA} = 1.2\text{ V} \pm 0.1\text{ V}$**

over recommended operating free-air temperature range (unless otherwise noted)

			$V_{CCB} = 1.2\text{ V} \pm 0.1\text{ V}$		$V_{CCB} = 1.5\text{ V} \pm 0.1\text{ V}$		$V_{CCB} = 1.8\text{ V} \pm 0.15\text{ V}$		$V_{CCB} = 2.5\text{ V} \pm 0.2\text{ V}$		$V_{CCB} = 3.3\text{ V} \pm 0.3\text{ V}$		UNIT
			MIN	MAX	MIN	MAX	MIN	MAX	MIN	MAX	MIN	MAX	
Data rate	Command	Push-pull driving	30		40		40		40		40		Mbps
		Open-drain driving	0.9		1		1		1		1		
	Clock	Push-pull driving	30		40		50		60		60		MHz
		Data	30		40		40		40		40		
$t_w$ Pulse duration	Command	Push-pull driving	33		25		25		25		25		ns
		Open-drain driving	1		1		1		1		1		
	Clock	Push-pull driving	16.7		12.5		10		8.3		8.3		ns
		Data	33		25		25		25		25		

**TIMING REQUIREMENTS**

**$V_{CCA} = 1.5\text{ V} \pm 0.1\text{ V}$**

over recommended operating free-air temperature range (unless otherwise noted)

			$V_{CCB} = 1.2\text{ V} \pm 0.1\text{ V}$		$V_{CCB} = 1.5\text{ V} \pm 0.1\text{ V}$		$V_{CCB} = 1.8\text{ V} \pm 0.15\text{ V}$		$V_{CCB} = 2.5\text{ V} \pm 0.2\text{ V}$		$V_{CCB} = 3.3\text{ V} \pm 0.3\text{ V}$		UNIT
			MIN	MAX	MIN	MAX	MIN	MAX	MIN	MAX	MIN	MAX	
Data rate	Command	Push-pull driving	30		60		60		60		60		Mbps
		Open-drain driving	1		1		1		1		1		
	Clock	Push-pull driving	50		60		60		60		60		MHz
		Data	30		60		60		60		60		
$t_w$ Pulse duration	Command	Push-pull driving	33		17		17		17		17		ns
		Open-drain driving	1		1		1		1		1		
	Clock	Push-pull driving	10		8.3		8.3		8.3		8.3		ns
		Data	33		17		17		17		17		

**TIMING REQUIREMENTS**

**$V_{CCA} = 1.8\text{ V} \pm 0.15\text{ V}$**

over recommended operating free-air temperature range (unless otherwise noted)

			$V_{CCB} = 1.2\text{ V} \pm 0.1\text{ V}$		$V_{CCB} = 1.5\text{ V} \pm 0.1\text{ V}$		$V_{CCB} = 1.8\text{ V} \pm 0.15\text{ V}$		$V_{CCB} = 2.5\text{ V} \pm 0.2\text{ V}$		$V_{CCB} = 3.3\text{ V} \pm 0.3\text{ V}$		UNIT
			MIN	MAX	MIN	MAX	MIN	MAX	MIN	MAX	MIN	MAX	
Data rate	Command	Push-pull driving	30		60		60		60		60		Mbps
		Open-drain driving	1		1		1		1		1		
	Clock	Push-pull driving	50		60		60		60		60		MHz
		Data	30		60		60		60		60		
$t_w$ Pulse duration	Command	Push-pull driving	33		17		17		17		17		ns
		Open-drain driving	1		1		1		1		1		
	Clock	Push-pull driving	10		8.3		8.3		8.3		8.3		ns
		Data	33		17		17		17		17		

**TIMING REQUIREMENTS**

$V_{CCA} = 2.5 \text{ V} \pm 0.2 \text{ V}$

over recommended operating free-air temperature range (unless otherwise noted)

			$V_{CCB} = 1.2 \text{ V} \pm 0.1 \text{ V}$		$V_{CCB} = 1.5 \text{ V} \pm 0.1 \text{ V}$		$V_{CCB} = 1.8 \text{ V} \pm 0.15 \text{ V}$		$V_{CCB} = 2.5 \text{ V} \pm 0.2 \text{ V}$		$V_{CCB} = 3.3 \text{ V} \pm 0.3 \text{ V}$		UNIT
			MIN	MAX	MIN	MAX	MIN	MAX	MIN	MAX	MIN	MAX	
Data rate	Command	Push-pull driving	30		60		60		60		60		Mbps
		Open-drain driving	1		1		1		1		1		
	Clock	Push-pull driving	60		60		60		60		60		MHz
		Data	30		60		60		60		60		
$t_w$ Pulse duration	Command	Push-pull driving	33		17		17		17		17		ns
		Open-drain driving	1		1		1		1		1		
	Clock	Push-pull driving	8.3		8.3		8.3		8.3		8.3		ns
		Data	33		17		17		17		17		

**TIMING REQUIREMENTS**

$V_{CCA} = 3.3 \text{ V} \pm 0.3 \text{ V}$

over recommended operating free-air temperature range (unless otherwise noted)

			$V_{CCB} = 1.2 \text{ V} \pm 0.1 \text{ V}$		$V_{CCB} = 1.5 \text{ V} \pm 0.1 \text{ V}$		$V_{CCB} = 1.8 \text{ V} \pm 0.15 \text{ V}$		$V_{CCB} = 2.5 \text{ V} \pm 0.2 \text{ V}$		$V_{CCB} = 3.3 \text{ V} \pm 0.3 \text{ V}$		UNIT
			MIN	MAX	MIN	MAX	MIN	MAX	MIN	MAX	MIN	MAX	
Data rate	Command	Push-pull driving	30		60		60		60		60		Mbps
		Open-drain driving	0.9		1		1		1		1		
	Clock	Push-pull driving	55		55		55		55		55		MHz
		Data	30		60		60		60		60		
$t_w$ Pulse duration	Command	Push-pull driving	33		17		17		17		17		ns
		Open-drain driving	1		1		1		1		1		
	Clock	Push-pull driving	9		9		9		9		9		ns
		Data	33		17		17		17		17		

**SWITCHING CHARACTERISTICS**

$V_{CCA} = 1.2 \text{ V} \pm 0.1 \text{ V}$

over recommended operating free-air temperature range (unless otherwise noted)

PARAMETER	FROM (INPUT)	TO (OUTPUT)	TEST CONDITIONS	$V_{CCB} = 1.2 \text{ V} \pm 0.1 \text{ V}$		$V_{CCB} = 1.5 \text{ V} \pm 0.1 \text{ V}$		$V_{CCB} = 1.8 \text{ V} \pm 0.15 \text{ V}$		$V_{CCB} = 2.5 \text{ V} \pm 0.2 \text{ V}$		$V_{CCB} = 3.3 \text{ V} \pm 0.3 \text{ V}$		UNIT
				MIN	MAX	MIN	MAX	MIN	MAX	MIN	MAX	MIN	MAX	
$t_{pd}$	CMDA	CMDB	Push-pull driving	15.3		12.2		10.8		10.4		10.8		ns
			Open-drain driving (H-to-L)	4.1	16.6	3.7	12.6	3.4	11.5	3.3	10.6	3.2	10.3	
			Open-drain driving (L-to-H)	204	308	164	256	133	224	95	175	71	147	
	CMDB	CMDA	Push-pull driving	19.7		15.1		13.4		12		11.2		
			Open-drain driving (H-to-L)	4.7	19.4	3.8	12.4	3.4	10.5	3.1	9.2	2.9	9.4	
			Open-drain driving (L-to-H)	211	353	170	304	139	282	101	243	77	204	
	CLKA	CLKB	Push-pull driving	15.6		12.3		11.5		10.9		11.7		
	DATxA	DATxB	Push-pull driving	15.9		12.6		11.2		10.7		11.1		
	DATxB	DATxA		18.2		14.3		12.8		11.5		10.6		
CLKA	CLK-f	Push-pull driving	37.9		30.7		26.8		24.7		24.2			
$t_{en}$	EN	B-port	Push-pull driving	1		1		1		1		1		$\mu\text{s}$
	EN	A-port	Push-pull driving	1		1		1		1		1		
$t_{dis}$	EN	B-port	Push-pull driving	68		55		46		40		38		ns
	EN	A-port	Push-pull driving	62		56		48		40		37		
$t_{rA}$	CMDA rise time		Push-pull driving	1.7	14.1	1.5	13	1.5	12.7	1.6	12.2	1.9	11.9	ns
			Open-drain driving	170	260	128	205	96	171	57	120	32	91	
	CLK-f rise time		Push-pull driving	0.6	10.6	0.6	10.9	0.6	12	0.6	12.3	0.6	12.7	
DATxA rise time			1.7	13.7	1.5	12.6	1.5	12	1.6	11.6	1.9	11.5		
$t_{rB}$	CMDB rise time		Push-pull driving	1.9	12.4	2.3	9.2	1.9	7.3	1.8	6.7	1.7	3.9	ns
			Open-drain driving	175	300	145	261	118	245	86	214	66	181	
	CLKB rise time		Push-pull driving	1	7.7	0.8	7.1	0.8	6.2	1.7	4.8	1.7	4.3	
	DATxB rise time			2.9	11.8	2.3	8.9	1.9	7.4	0.9	4.7	0.4	6.8	
$t_{fA}$	CMDA fall time		Push-pull driving	1	8	1	5.4	1	4.5	1	3.9	0.8	4	ns
			Open-drain driving	2.3	8.3	1.9	4.9	1.7	4.4	1.6	3.9	1.6	3.7	
	CLK-f fall time		Push-pull driving	1	5.8	1	4.6	1	4.1	1	3.8	1	4	
	DATxA fall time			1.8	8	1.3	5.4	1	4.5	1	3.9	1	3.8	
$t_{fB}$	CMDB fall time		Push-pull driving	2.1	7.9	1.8	5.2	1.7	4.6	1.6	4.5	1.5	4.3	ns
			Open-drain driving	1.9	8.3	1.5	5.9	1.3	5.1	1.1	4.3	1	4.2	
	CLKB fall time		Push-pull driving	2	7.1	1.8	5.4	1.8	4.5	1.7	4	1.6	3.9	
	DATxB fall time			2.1	8.5	1.1	6.4	0.9	5	1	3.9	1.1	4.8	
$t_{SK(O)}$	Channel-to-channel skew		Push-pull driving	1		1		1		1		1		ns
Max data rate	Command		Push-pull driving	30		40		40		40		40		Mbps
			Open-drain driving	0.9		1		1		1		1		
	Data		Push-pull driving	30		40		50		60		60		MHz
				30		40		40		40		40		

**SWITCHING CHARACTERISTICS**

$V_{CCA} = 1.5 \text{ V} \pm 0.1 \text{ V}$

over recommended operating free-air temperature range (unless otherwise noted)

PARAMETER	FROM (INPUT)	TO (OUTPUT)	TEST CONDITIONS	$V_{CCB} = 1.2 \text{ V} \pm 0.1 \text{ V}$		$V_{CCB} = 1.5 \text{ V} \pm 0.1 \text{ V}$		$V_{CCB} = 1.8 \text{ V} \pm 0.15 \text{ V}$		$V_{CCB} = 2.5 \text{ V} \pm 0.2 \text{ V}$		$V_{CCB} = 3.3 \text{ V} \pm 0.3 \text{ V}$		UNIT
				MIN	MAX	MIN	MAX	MIN	MAX	MIN	MAX	MIN	MAX	
$t_{pd}$	CMDA	CMDB	Push-pull driving	12		8.6		6.9		6.1		6		ns
			Open-drain driving (H-to-L)	3.7	12.8	3.2	8.7	2.9	7.6	2.7	6.6	2.7	6.5	
			Open-drain driving (L-to-H)	192	297	191	295	157	252	112	180	83	138	
	CMDB	CMDA	Push-pull driving	15.2		9.8		8		6.8		6.3		
			Open-drain driving (H-to-L)	3.7	20.4	2.9	11.8	2.5	9.4	2.2	7.3	2.1	6.6	
			Open-drain driving (L-to-H)	199	337	196	316	162	282	117	214	87	177	
	CLKA	CLKB	Push-pull driving	12.3		8.7		7.7		6.1		6.2		
	DATxA	DATxB	Push-pull driving	12.5		8.9		7.2		6.2		6.1		
	DATxB	DATxA		13.9		9.2		7.6		6.5		6.1		
CLKA	CLK-f	Push-pull driving	29		20		16		13		12			
$t_{en}$	EN	B-port	Push-pull driving	1		1		1		1		1		$\mu\text{s}$
	EN	A-port	Push-pull driving	1		1		1		1		1		
$t_{dis}$	EN	B-port	Push-pull driving	57		53		46		39		37		ns
	EN	A-port	Push-pull driving	58		54		46		38		35		
$t_{rA}$	CMDA rise time		Push-pull driving	1.6	10.5	0.4	9.5	0.2	8.9	0.4	8.3	1	7.9	ns
			Open-drain driving	166	254	157	247	121	203	74	127	44	85	
	CLK-f rise time		Push-pull driving	0.5	5.5	0.5	5.5	0.5	6.2	0.5	7	0.5	7.2	
DATxA rise time			2	10.3	0.7	9.4	0.5	8.9	0.6	8.4	0.7	8.3		
$t_{rB}$	CMDB rise time		Push-pull driving	1.9	11.2	2	8	1.9	6.5	0.5	5.6	0.5	3.1	ns
			Open-drain driving	157	273	163	264	135	253	96	196	71	165	
	CLKB rise time		Push-pull driving	1.3	7.5	0.6	6.7	0.4	5.9	1.5	4.9	1.9	4.3	
	DATxB rise time			2.2	10.9	2	8.4	1.7	6.9	0.8	5	0.6	4	
$t_{fA}$	CMDA fall time		Push-pull driving	1.5	5.5	1.3	3.8	0.9	2.9	0.8	2.3	0.8	2.3	ns
			Open-drain driving	2.3	8	2	4.8	1.8	4.2	1.7	3.7	1.6	3.5	
	CLK-f fall time		Push-pull driving	0.4	3.9	0.4	3.7	0.4	4	0.4	3.7	0.4	6.8	
	DATxA fall time			0.8	6	0.6	4.8	0.1	4.1	0.1	3.8	0.1	3.8	
$t_{fB}$	CMDB fall time		Push-pull driving	1	11.6	1.5	7.1	1.5	5.8	1.4	5.4	1.6	3.6	ns
			Open-drain driving	1.7	5.2	1.5	3.8	1.2	3	1	2.3	0.9	2.3	
	CLKB fall time		Push-pull driving	1.1	10.8	1	8.8	1.8	6	1.7	4.1	1.6	3.9	
	DATxB fall time			1.1	13.3	1.2	7.7	1.2	6.5	2.3	4.3	2.5	4.2	
$t_{SK(O)}$	Channel-to-channel skew		Push-pull driving	1		1		1		1		1		ns
Max data rate	Command		Push-pull driving	30		60		60		60		60		Mbps
			Open-drain driving	1		1		1		1		1		
	Data		Push-pull driving	50		60		60		60		60		MHz
				30		60		60		60		60		

**SWITCHING CHARACTERISTICS**

$V_{CCA} = 1.8 \text{ V} \pm 0.15 \text{ V}$

over recommended operating free-air temperature range (unless otherwise noted)

PARAMETER	FROM (INPUT)	TO (OUTPUT)	TEST CONDITIONS	$V_{CCB} = 1.2 \text{ V} \pm 0.1 \text{ V}$		$V_{CCB} = 1.5 \text{ V} \pm 0.1 \text{ V}$		$V_{CCB} = 1.8 \text{ V} \pm 0.15 \text{ V}$		$V_{CCB} = 2.5 \text{ V} \pm 0.2 \text{ V}$		$V_{CCB} = 3.3 \text{ V} \pm 0.3 \text{ V}$		UNIT
				MIN	MAX	MIN	MAX	MIN	MAX	MIN	MAX	MIN	MAX	
$t_{pd}$	CMDA	CMDB	Push-pull driving	11.3		7.3		5.7		4.6		4.4		ns
			Open-drain driving (H-to-L)	3.4	11.8	2.9	7.6	2.7	6.5	2.5	5.5	2.4	5.1	
			Open-drain driving (L-to-H)	179	286	183	288	168	286	121	201	89	151	
	CMDB	CMDA	Push-pull driving	13.2		8.3		6.5		5.2		4.8		
			Open-drain driving (H-to-L)	3.5	19.7	2.8	11.1	2.4	8.6	2.1	6.4	2	5.7	
			Open-drain driving (L-to-H)	186	323	190	304	173	303	125	215	93	166	
	CLKA	CLKB	Push-pull driving	11.6		7.7		6.2		4.7		4.5		
	DATxA	DATxB	Push-pull driving	11.7		7.5		5.8		4.7		4.4		
	DATxB	DATxA		12.1		7.9		6.3		5		4.6		
CLKA	CLK-f	Push-pull driving	25.1		16.5		12		8.9		7.9			
$t_{en}$	EN	B-port	Push-pull driving	1		1		1		1		1		$\mu\text{s}$
	EN	A-port	Push-pull driving	1		1		1		1		1		
$t_{dis}$	EN	B-port	Push-pull driving	39		37		37		35		35		ns
	EN	A-port	Push-pull driving	49		47		47		38		35		
$t_{rA}$	CMDA rise time		Push-pull driving	1.8	8.4	1.2	6.8	1.1	5.9	1.1	5.9	1.6	5.8	ns
			Open-drain driving	154	246	155	262	135	238	85	150	52	99	
	CLK-f rise time		Push-pull driving	0.4	4	0.4	4.3	0.4	4.7	0.4	4.5	0.4	4.1	
DATxA rise time			1.9	8.6	1.2	7.1	0.9	6.8	1	6.3	1.3	6.1		
$t_{rB}$	CMDB rise time		Push-pull driving	1.8	10.2	2	7.7	1.7	6.5	1	5.2	1.7	3.1	ns
			Open-drain driving	137	251	148	245	141	251	100	184	73	142	
	CLKB rise time		Push-pull driving	1.5	7.3	0.7	6.6	0.4	5.9	1.5	4.9	1.9	4.3	
DATxB rise time			2.3	10.3	1.8	8	1.5	6.8	0.9	5.2	0.2	5		
$t_{fA}$	CMDA fall time		Push-pull driving	0.6	4.5	0.4	3.8	0.2	3.3	0.2	2.9	0.2	3.1	ns
			Open-drain driving	2.3	7.9	2	4.8	1.8	4.2	1.7	3.7	1.6	3.5	
	CLK-f fall time		Push-pull driving	0.1	2	0.2	2.2	0.7	1.6	0.7	1.5	0.1	3	
DATxA fall time			1	4.3	0.8	3.6	1	2.7	0.1	2.7	0.2	2.6		
$t_{fB}$	CMDB fall time		Push-pull driving	1	10.3	1.4	6.8	1.8	5.4	1.6	5	1.6	3.6	ns
			Open-drain driving	1.4	4	1.3	3	1.2	2.6	0.9	1.9	0.8	1.8	
	CLKB fall time		Push-pull driving	1.1	10.8	1	10.3	1.4	6.3	1.8	4.2	1.7	4	
DATxB fall time			1	11.8	15	7	1.2	6.3	1.6	4.9	0.8	3.6		
$t_{SK(O)}$	Channel-to-channel skew		Push-pull driving	1		1		1		1		1		ns
Max data rate	Command		Push-pull driving	30		60		60		60		60		Mbps
			Open-drain driving	1		1		1		1		1		
	Data		Push-pull driving	50		60		60		60		60		MHz
			Push-pull driving	30		60		60		60		60		

**SWITCHING CHARACTERISTICS**

$V_{CCA} = 2.5 \text{ V} \pm 0.2 \text{ V}$

over recommended operating free-air temperature range (unless otherwise noted)

PARAMETER	FROM (INPUT)	TO (OUTPUT)	TEST CONDITIONS	$V_{CCB} = 1.2 \text{ V} \pm 0.1 \text{ V}$		$V_{CCB} = 1.5 \text{ V} \pm 0.1 \text{ V}$		$V_{CCB} = 1.8 \text{ V} \pm 0.15 \text{ V}$		$V_{CCB} = 2.5 \text{ V} \pm 0.2 \text{ V}$		$V_{CCB} = 3.3 \text{ V} \pm 0.3 \text{ V}$		UNIT	
				MIN	MAX	MIN	MAX	MIN	MAX	MIN	MAX	MIN	MAX		
$t_{pd}$	CMDA	CMDB	Push-pull driving	10.6		6.5		4.9		3.7		3.3		ns	
			Open-drain driving (H-to-L)	3.2	10.9	2.7	6.7	2.4	5.5	2.2	4.4	2.1	4.1		
			Open-drain driving (L-to-H)	156	253	162	258	149	261	126	249	98	190		
	CMDB	CMDA	Push-pull driving	12.5		7.4		5.6		4.1		3.6			ns
			Open-drain driving (H-to-L)	3.5	19.2	2.7	10.5	2.3	7.9	2	5.7	1.9	4.8		
			Open-drain driving (L-to-H)	163	295	169	273	158	274	131	261	99	202		
	CLKA	CLKB	Push-pull driving	10.8		6.8		5.4		3.7		3.4			ns
	DATxA	DATxB	Push-pull driving	10.9		6.7		5		3.7		3.3			
	DATxB	DATxA		11.5		7.1		5.4		3.9		3.5			
CLKA	CLK-f	Push-pull driving	23.7		14.9		10.2		6.8		5.7				
$t_{en}$	EN	B-port	Push-pull driving	1		1		1		1		1		$\mu\text{s}$	
	EN	A-port	Push-pull driving	1		1		1		1		1			
$t_{dis}$	EN	B-port	Push-pull driving	48		45		45		38		36		ns	
	EN	A-port	Push-pull driving	45		38		38		38		35			
$t_{rA}$	CMDA rise time		Push-pull driving	1.9	4.7	1.7	4.4	1.7	3.8	1.9	3.2	2.3	3.3	ns	
			Open-drain driving	135	216	136	237	121	228	96	201	62	141		
	CLK-f rise time		Push-pull driving	0.8	1.6	0.3	1.9	0.6	1.8	0.7	1.5	0.7	1.3		
	DATxA rise time		Push-pull driving	1.9	6.1	1.8	4.5	1.7	4.1	1.9	4	1.8	4.2		
$t_{rB}$	CMDB rise time		Push-pull driving	1.7	10.8	2.9	7.6	1.8	6.6	1.5	5.2	1.5	3.8	ns	
			Open-drain driving	102	205	116	197	112	207	101	214	76	165		
	CLKB rise time		Push-pull driving	1.6	7.3	0.5	6.8	0.4	5.8	1.6	5	1.7	4.4		
	DATxB rise time		Push-pull driving	2.2	10.3	1.9	7.9	1.8	6.6	1.4	5.3	0.9	4.4		
$t_{fA}$	CMDA fall time		Push-pull driving	0.4	2.4	0.4	1.6	0.4	1.5	0.5	1.5	0.3	1.4	ns	
			Open-drain driving	2.2	7.6	1.9	4.8	1.8	4.2	1.7	3.7	1.6	3.5		
	CLK-f fall time		Push-pull driving	0.3	2.2	0.3	2.7	0.3	2.6	0.3	2.4	0.3	2.8		
	DATxA fall time		Push-pull driving	0.4	4	0.4	3.6	0.4	3.2	0.5	2.9	0.3	2.6		
$t_{fB}$	CMDB fall time		Push-pull driving	1	13.4	1.8	7.2	1.7	6.3	1.6	5.6	1.6	3.7	ns	
			Open-drain driving	1	2.3	1	1.7	1	1.7	1	1.6	0.8	1.4		
	CLKB fall time		Push-pull driving	1.1	12.7	1	11.3	0.9	8.7	1.8	4.5	1.7	4.1		
	DATxB fall time		Push-pull driving	1	16	0.7	9	0.8	7	0.8	4.9	0.2	4		
$t_{SK(O)}$	Channel-to-channel skew		Push-pull driving	1		1		1		1		1		ns	
Max data rate	Command		Push-pull driving	30		60		60		60		60		Mbps	
			Open-drain driving	1		1		1		1		1			
	Data		Push-pull driving	50		60		60		60		60		MHz	
			Push-pull driving	30		60		60		60		60			

**SWITCHING CHARACTERISTICS**

$V_{CCA} = 3.3 \text{ V} \pm 0.3 \text{ V}$

over recommended operating free-air temperature range (unless otherwise noted)

PARAMETER	FROM (INPUT)	TO (OUTPUT)	TEST CONDITIONS	$V_{CCB} = 1.2 \text{ V} \pm 0.1 \text{ V}$		$V_{CCB} = 1.5 \text{ V} \pm 0.1 \text{ V}$		$V_{CCB} = 1.8 \text{ V} \pm 0.15 \text{ V}$		$V_{CCB} = 2.5 \text{ V} \pm 0.2 \text{ V}$		$V_{CCB} = 3.3 \text{ V} \pm 0.3 \text{ V}$		UNIT
				MIN	MAX	MIN	MAX	MIN	MAX	MIN	MAX	MIN	MAX	
$t_{pd}$	CMDA	CMDB	Push-pull driving	12.5		7.2		5.3		3.8		3.2		ns
			Open-drain driving (H-to-L)	3.2	10.6	2.7	6.4	2.4	5.2	2.1	4.1	2	3.7	
			Open-drain driving (L-to-H)	136	212	141	235	129	235	112	233	101	201	
	CMDB	CMDA	Push-pull driving	10.7		6.6		5.1		3.4		3		
			Open-drain driving (H-to-L)	4.3	16.4	3.3	8.7	2.8	6.6	2.4	4.6	2.2	3.6	
			Open-drain driving (L-to-H)	142	273	148	246	139	248	122	248	105	212	
	CLKA	CLKB	Push-pull driving	10.8		6.5		4.8		3.5		3.1		
	DATxA	DATxB	Push-pull driving	11.5		6.9		5.1		3.7		3.2		
	DATxB	DATxA		23.6		14.4		9.6		6.2		5.1		
CLKA	CLK-f	Push-pull driving	17.1		9.1		6.8		4.8		4.2			
$t_{en}$	EN	B-port	Push-pull driving	1		1		1		1		1		$\mu\text{s}$
	EN	A-port	Push-pull driving	1		1		1		1		1		
$t_{dis}$	EN	B-port	Push-pull driving	38		34		34		34		34		ns
	EN	A-port	Push-pull driving	45		37		36		36		35		
$t_{rA}$	CMDA rise time		Push-pull driving	0.7	5.6	0.7	5	0.7	4.2	0.8	4.1	1	4.2	ns
			Open-drain driving	117	178	118	213	104	206	85	194	74	155	
	CLK-f rise time	Push-pull driving	0.7	1.5	0.5	1.7	0.7	1.5	0.7	1.4	0.7	1.4		
	DATxA rise time		0.9	5	1.1	3.9	1.3	3.4	1.4	3.3	1.1	3		
$t_{rB}$	CMDB rise time		Push-pull driving	1.7	10.8	2.3	7.4	2.2	6.4	2	5	1.9	4	ns
			Open-drain driving	69	167	84	156	83	167	79	185	79	166	
	CLKB rise time	Push-pull driving	1	7.7	0.3	7.1	0.5	5.9	1.6	5.1	1.9	4.4		
	DATxB rise time		2.1	10.5	2	7.9	2	6.6	1.8	5.3	1	14		
$t_{fA}$	CMDA fall time		Push-pull driving	0.3	2.8	0.4	2.4	0.4	2	0.4	2	1	2.3	ns
			Open-drain driving	2	7.6	1.8	5	1.7	4.4	1.6	3.9	1.6	3.7	
	CLK-f fall time	Push-pull driving	0.6	1.3	0.6	1.3	0.6	1.3	0.6	1.3	0.6	1.3		
	DATxA fall time		0.3	2.7	0.4	2.3	0.4	1.4	0.4	1.8	0.5	1.7		
$t_{fB}$	CMDB fall time		Push-pull driving	1	13.3	0.7	7.9	0.9	6.2	0.8	6.3	1	5	ns
			Open-drain driving	0.7	1.5	0.7	1.4	0.8	1.4	0.9	1.3	0.9	1.3	
	CLKB fall time	Push-pull driving	1	15.5	1	9.1	0.9	7.8	0.9	5.1	0.9	4.3		
	DATxB fall time		1	15	0.9	6.8	0.9	6.8	0.8	6.9	0.8	5		
$t_{SK(O)}$	Channel-to-channel skew	Push-pull driving	1		1		1		1		1		ns	
Max data rate	Command		Push-pull driving	30		60		60		60		60		Mbps
			Open-drain driving	0.9		1		1		1		1		
	Data		Push-pull driving	55		55		55		55		55		MHz
				30		60		60		60		60		

**OPERATING CHARACTERISTICS**
 $T_A = 25^\circ\text{C}$ ,  $V_{CCA} = 1.2\text{ V}$ 

PARAMETER			TEST CONDITIONS	$V_{CCB}$ TYP						UNIT		
				1.2 V	1.5 V	1.8 V	2.5 V	3 V	3.3 V			
$C_{pdA}$ (1)	A-port input, B-port output	CLK Enabled	$C_L = 0$ , $f = 10\text{ MHz}$ , $t_r = t_f = 1\text{ ns}$	15	15	14.9	14.9	15	15	pF		
		DATA Enabled		6.3	6.4	6.5	6.5	6.5	6.5			
	B-port input, A-port output	DATA Enabled		12.5	12.3	12.3	12.1	12	11.9			
		CLK Disabled		0.2	0.2	0.2	0.3	0.3	0.3			
	A-port input, B-port output	DATA Disabled		1.2	1.2	1.2	1.2	1.2	1.2			
DATA Disabled		0.2		0.2	0.2	0.3	0.3	0.3				
$C_{pdB}$ (1)	A-port input, B-port output	DATA Enabled		$C_L = 0$ , $f = 10\text{ MHz}$ , $t_r = t_f = 1\text{ ns}$	26.2	27.3	28.2	29.7	30		31.2	pF
		CLK Enabled			25.7	25.6	25.6	26.4	27		28.1	
	B-port input, A-port output	DATA Enabled			13.7	12.2	11.4	12	12.5		12.9	
		DATA Disabled			0.6	0.5	0.5	0.5	0.5		0.6	
	A-port input, B-port output	CLK Disabled	0.6		0.5	0.5	0.5	0.5	0.6			
		DATA Disabled	1.2		1.2	1.2	1	1	0.9			

(1) Power dissipation capacitance per transceiver

**OPERATING CHARACTERISTICS**
 $T_A = 25^\circ\text{C}$ ,  $V_{CCA} = 1.5\text{ V}$ 

PARAMETER			TEST CONDITIONS	$V_{CCB}$ TYP						UNIT
				1.2 V	1.5 V	1.8 V	2.5 V	3 V	3.3 V	
$C_{pdA}$ (1)	A-port input, B-port output	CLK Enabled	$C_L = 0$ , $f = 10\text{ MHz}$ , $t_r = t_f = 1\text{ ns}$	15	15	15	14.9	14.9	14.9	pF
		DATA Enabled		6.4	6.3	6.2	6	6	6	
	B-port input, A-port output	DATA Enabled		13.2	12.3	12.2	12	12	11.9	
		CLK Disabled		0.1	0.1	0.1	0.1	0.1	0.1	
	A-port input, B-port output	DATA Disabled		1.2	1.2	1.2	1.2	1.2	1.2	
		DATA Disabled		0.1	0.1	0.1	0.1	0.1	0.1	

(1) Power dissipation capacitance per transceiver

**OPERATING CHARACTERISTICS (continued)** $T_A = 25^\circ\text{C}$ ,  $V_{CCA} = 1.5\text{ V}$ 

PARAMETER			TEST CONDITIONS	$V_{CCB}$ TYP						UNIT
				1.2 V	1.5 V	1.8 V	2.5 V	3 V	3.3 V	
$C_{pdB}$ (1)	A-port input, B-port output	DATA Enabled	$C_L = 0$ , $f = 10\text{ MHz}$ , $t_r = t_f = 1\text{ ns}$	25.8	26.3	27.3	29.2	29.2	30.6	pF
	B-port input, A-port output	CLK Enabled		25.8	25.6	25.6	26.2	26.2	27.2	
		DATA Enabled		13.7	12.3	11.4	12	12	12.8	
	A-port input, B-port output	DATA Disabled		0.1	0.1	0.1	0.1	0.1	0.1	
	B-port input, A-port output	CLK Disabled		0.1	0.1	0.1	0.1	0.1	0.1	
		DATA Disabled		1.2	1.2	1.1	1	1	0.9	

**OPERATING CHARACTERISTICS** $T_A = 25^\circ\text{C}$ ,  $V_{CCA} = 1.8\text{ V}$ 

PARAMETER			TEST CONDITIONS	$V_{CCB}$ TYP						UNIT
				1.2 V	1.5 V	1.8 V	2.5 V	3 V	3.3 V	
$C_{pdA}$ (1)	A-port input, B-port output	CLK Enabled	$C_L = 0$ , $f = 10\text{ MHz}$ , $t_r = t_f = 1\text{ ns}$	15.2	15.1	15.1	15	15	15	pF
		DATA Enabled		6.7	6.2	5.8	5.4	5.4	5.3	
	B-port input, A-port output	DATA Enabled		13.9	13.1	12.4	12.1	12	11.9	
	A-port input, B-port output	CLK Disabled		0.1	0.1	0.1	0.1	0.1	0.1	
		DATA Disabled		1.3	1.3	1.3	1.3	1.3	1.3	
	B-port input, A-port output	DATA Disabled		0.1	0.1	0.1	0.1	0.1	0.1	
$C_{pdB}$ (1)	A-port input, B-port output	DATA Enabled	$C_L = 0$ , $f = 10\text{ MHz}$ , $t_r = t_f = 1\text{ ns}$	25.9	26.1	26.7	28.8	28.8	30.3	pF
	B-port input, A-port output	CLK Enabled		25.8	25.6	25.6	26.2	26.2	27	
		DATA Enabled		13.6	12.2	11.5	12.1	12.1	12.9	
	A-port input, B-port output	DATA Disabled		0.2	0.1	0.1	0.1	0.1	0.1	
	B-port input, A-port output	CLK Disabled		0.2	0.1	0.1	0.1	0.1	0.1	
		DATA Disabled		1.2	1.2	1.1	1	1	0.8	

(1) Power dissipation capacitance per transceiver

**OPERATING CHARACTERISTICS**
 $T_A = 25^\circ\text{C}$ ,  $V_{CCA} = 2.5\text{ V}$ 

PARAMETER			TEST CONDITIONS	$V_{CCB}$ TYP						UNIT		
				1.2 V	1.5 V	1.8 V	2.5 V	3 V	3.3 V			
$C_{pdA}$ (1)	A-port input, B-port output	CLK Enabled	$C_L = 0$ , $f = 10\text{ MHz}$ , $t_r = t_f = 1\text{ ns}$	16.2	16	15.9	15.8	15.8	15.7	pF		
		DATA Enabled		7.3	6.5	5.9	5.5	5.4	5.3			
	B-port input, A-port output	DATA Enabled		15.3	14.6	14	13	12.8	12.5			
		CLK Disabled		0.1	0.1	0.1	0.1	0.1	0.1			
	A-port input, B-port output	DATA Disabled		1.3	1.3	1.3	1.3	1.3	1.3			
DATA Disabled		0.1		0.1	0.1	0.1	0.1	0.1				
$C_{pdB}$ (1)	A-port input, B-port output	DATA Enabled		$C_L = 0$ , $f = 10\text{ MHz}$ , $t_r = t_f = 1\text{ ns}$	25.6	25.8	26.2	27.6	29		29.5	pF
		CLK Enabled			25.9	25.7	25.7	26.2	26.5		26.9	
	B-port input, A-port output	DATA Enabled			13.6	12.2	11.5	12.3	12.7		13.2	
		DATA Disabled			0.3	0.1	0.1	0.1	0.1		0.1	
	A-port input, B-port output	DATA Disabled	0.3		0.1	0.1	0.1	0.1	0.1			
		DATA Disabled	1.2		1.2	1.1	1	0.9	0.8			

(1) Power dissipation capacitance per transceiver

**OPERATING CHARACTERISTICS**
 $T_A = 25^\circ\text{C}$ ,  $V_{CCA} = 3.3\text{ V}$ 

PARAMETER			TEST CONDITIONS	$V_{CCB}$ TYP						UNIT
				1.2 V	1.5 V	1.8 V	2.5 V	3 V	3.3 V	
$C_{pdA}$ (1)	A-port input, B-port output	CLK Enabled	$C_L = 0$ , $f = 10\text{ MHz}$ , $t_r = t_f = 1\text{ ns}$	18.3	17.7	17.5	17.3	17.2	17.1	pF
		DATA Enabled		8.1	7	6.2	5.7	5.6	5.6	
	B-port input, A-port output	DATA Enabled		17	16.1	15.6	14.8	14.4	14	
		CLK Disabled		0.1	0.1	0.1	0.1	0.1	0.1	
	A-port input, B-port output	DATA Disabled		1.3	1.3	1.3	1.3	1.3	1.3	
		DATA Disabled		0.1	0.1	0.1	0.1	0.1	0.1	

(1) Power dissipation capacitance per transceiver

**OPERATING CHARACTERISTICS (continued)**

T<sub>A</sub> = 25°C, V<sub>CCA</sub> = 3.3 V

PARAMETER			TEST CONDITIONS	V <sub>CCB</sub> TYP						UNIT
				1.2 V	1.5 V	1.8 V	2.5 V	3 V	3.3 V	
C <sub>pdB</sub> (1)	A-port input, B-port output	DATA Enabled	C <sub>L</sub> = 0, f = 10 MHz, t <sub>r</sub> = t <sub>f</sub> = 1 ns	25.2	25.6	26	27.1	28	28.5	pF
	B-port input, A-port output	CLK Enabled		26	25.8	25.8	26.3	26.8	27	
		DATA Enabled		13.7	12.1	11.4	12.2	12.7	13.2	
	A-port input, B-port output	DATA Disabled		0.3	0.1	0.1	0.1	0.1	0.1	
	B-port input, A-port output	CLK Disabled		0.3	0.1	0.1	0.1	0.1	0.1	
		DATA Disabled		1.2	1.2	1.1	1	0.9	0.8	

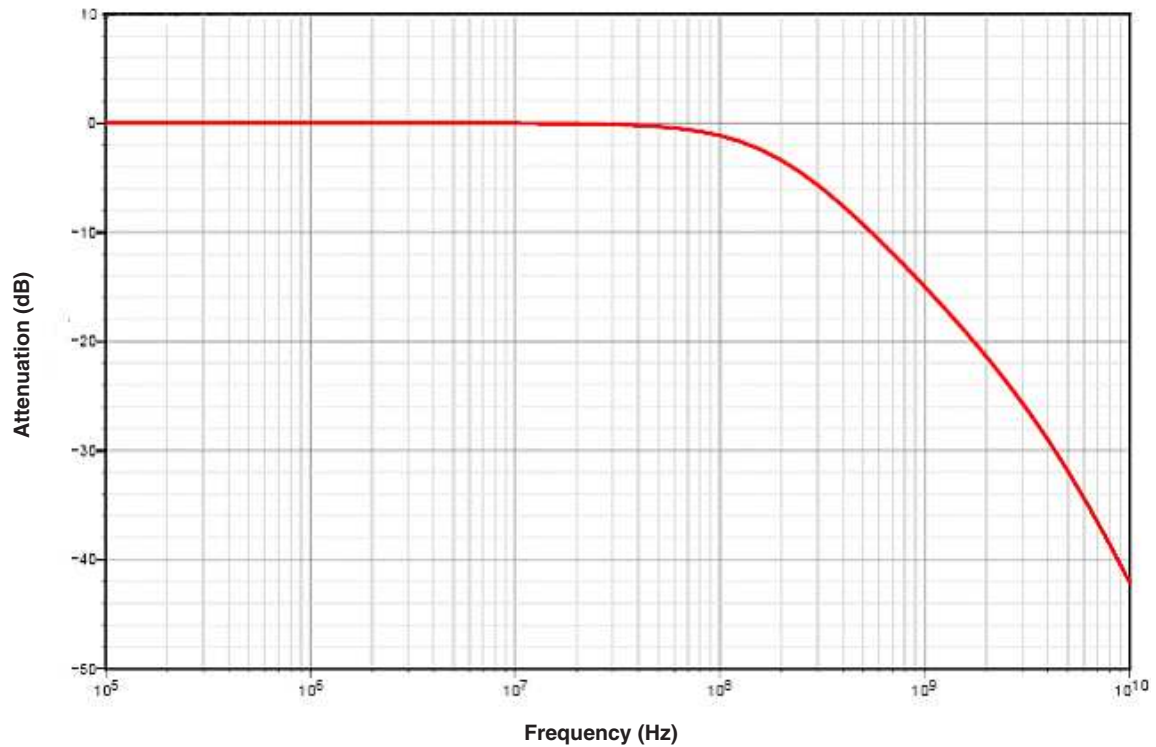
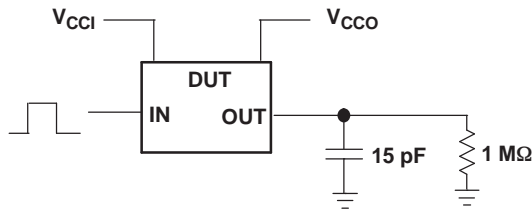
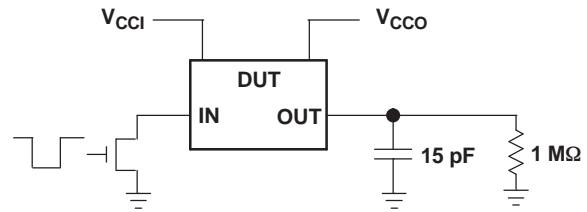
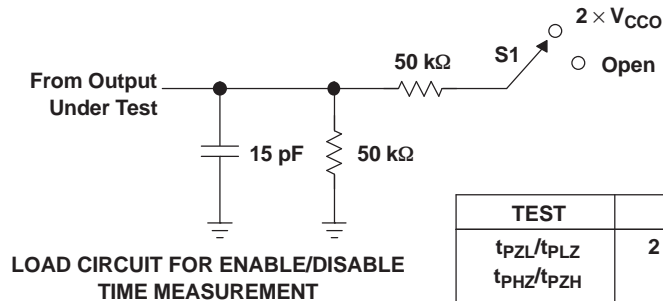
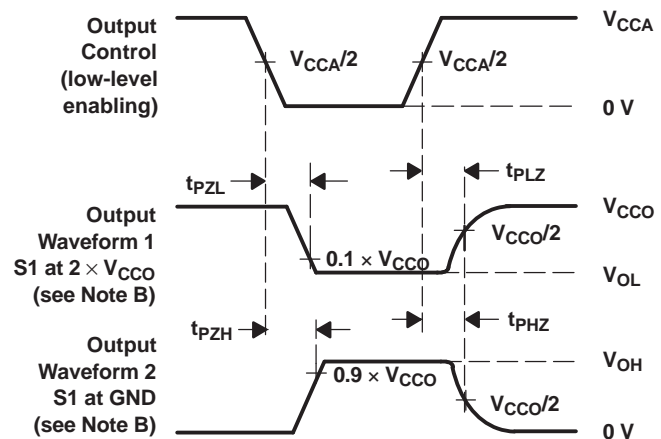
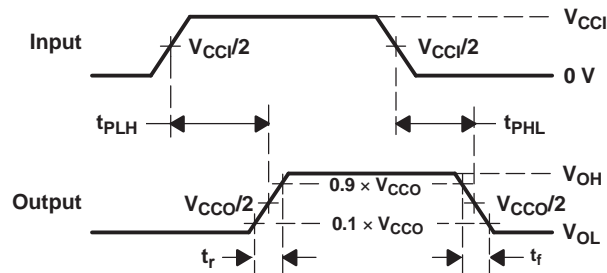
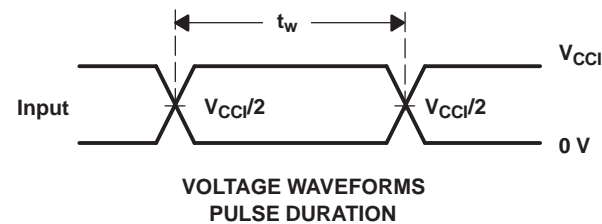

Figure 7. Typical ASIP EMI Filter Frequency Response

**PARAMETER MEASUREMENT INFORMATION**

**DATA RATE, PULSE DURATION, PROPAGATION DELAY, OUTPUT RISE AND FALL TIME MEASUREMENT USING A PUSH-PULL DRIVER**

**DATA RATE, PULSE DURATION, PROPAGATION DELAY, OUTPUT RISE AND FALL TIME MEASUREMENT USING AN OPEN-DRAIN DRIVER**

**LOAD CIRCUIT FOR ENABLE/DISABLE TIME MEASUREMENT**

- A.  $C_L$  includes probe and jig capacitance.
- B. Waveform 1 is for an output with internal conditions such that the output is low, except when disabled by the output control. Waveform 2 is for an output with internal conditions such that the output is high, except when disabled by the output control.
- C. All input pulses are supplied by generators having the following characteristics:  $PRR \leq 10$  MHz,  $Z_O = 50 \Omega$ ,  $dv/dt \geq 1$  V/ns.
- D. The outputs are measured one at a time, with one transition per measurement.
- E.  $t_{PZL}$  and  $t_{PHZ}$  are the same as  $t_{dis}$ .
- F.  $t_{PZL}$  and  $t_{PZH}$  are the same as  $t_{en}$ .
- G.  $t_{PLH}$  and  $t_{PHL}$  are the same as  $t_{pd}$ .
- H.  $V_{CCI}$  is the  $V_{CC}$  associated with the input port.
- I.  $V_{CCO}$  is the  $V_{CC}$  associated with the output port.
- J. All parameters and waveforms are not applicable to all devices.

---

**PARAMETER MEASUREMENT INFORMATION (continued)**

**Figure 8. Load Circuit and Voltage Waveforms**

## APPLICATION INFORMATION

The TXS0206 has integrated pullup resistors on the data and command ports and their values dynamically change. When the port is in a low signal state, there is a nominal pullup resistor value of 40 kΩ, and power consumption is minimized. When the port is in a high signal state, the nominal pullup resistor value changes to 4 kΩ, and simultaneous switching performance is improved as a result. The threshold at which the resistance changes is approximately  $V_{CC}/2$ .

When using the TXS0206 device with MMCs, SD, and Memory Stick™ to ensure that a valid receiver input voltage high ( $V_{IH}$ ) is achieved, the value of any pulldown resistors (external or internal to a memory card) must not be smaller than a 10-kΩ value. The impact of adding too heavy (i.e., <10-kΩ value) a pulldown resistor to the data and command lines of the TXS0206 device and the resulting 4-kΩ pullup / 10-kΩ pulldown voltage divider network has a direct impact on the  $V_{IH}$  of the signal being sent into the memory card and its associated logic.

The resulting  $V_{IH}$  voltage for the 10-kΩ pulldown resistor value would be:

$$V_{CC} \times 10 \text{ k}\Omega / (10 \text{ k}\Omega + 4 \text{ k}\Omega) = 0.714 \times V_{CC}$$

This is marginally above a valid input high voltage for a 1.8-V signal (i.e.,  $0.65 \times V_{CC}$ ).

The resulting  $V_{IH}$  voltage for 20-kΩ pulldown resistor value would be:

$$V_{CC} \times 20 \text{ k}\Omega / (20 \text{ k}\Omega + 4 \text{ k}\Omega) = 0.833 \times V_{CC}$$

Which is above the valid input high voltage for a 1.8-V signal of  $0.65 \times V_{CC}$ .

**PACKAGING INFORMATION**

Orderable Device	Status (1)	Package Type	Package Drawing	Pins	Package Qty	Eco Plan (2)	Lead/Ball Finish (6)	MSL Peak Temp (3)	Op Temp (°C)	Device Marking (4/5)	Samples
TXS0206YFPR	ACTIVE	DSBGA	YFP	20	3000	Green (RoHS & no Sb/Br)	SNAGCU	Level-1-260C-UNLIM	-40 to 85	(3T2 ~ 3TR)	<b>Samples</b>

(1) The marketing status values are defined as follows:

**ACTIVE:** Product device recommended for new designs.

**LIFEBUY:** TI has announced that the device will be discontinued, and a lifetime-buy period is in effect.

**NRND:** Not recommended for new designs. Device is in production to support existing customers, but TI does not recommend using this part in a new design.

**PREVIEW:** Device has been announced but is not in production. Samples may or may not be available.

**OBSOLETE:** TI has discontinued the production of the device.

(2) Eco Plan - The planned eco-friendly classification: Pb-Free (RoHS), Pb-Free (RoHS Exempt), or Green (RoHS & no Sb/Br) - please check <http://www.ti.com/productcontent> for the latest availability information and additional product content details.

**TBD:** The Pb-Free/Green conversion plan has not been defined.

**Pb-Free (RoHS):** TI's terms "Lead-Free" or "Pb-Free" mean semiconductor products that are compatible with the current RoHS requirements for all 6 substances, including the requirement that lead not exceed 0.1% by weight in homogeneous materials. Where designed to be soldered at high temperatures, TI Pb-Free products are suitable for use in specified lead-free processes.

**Pb-Free (RoHS Exempt):** This component has a RoHS exemption for either 1) lead-based flip-chip solder bumps used between the die and package, or 2) lead-based die adhesive used between the die and leadframe. The component is otherwise considered Pb-Free (RoHS compatible) as defined above.

**Green (RoHS & no Sb/Br):** TI defines "Green" to mean Pb-Free (RoHS compatible), and free of Bromine (Br) and Antimony (Sb) based flame retardants (Br or Sb do not exceed 0.1% by weight in homogeneous material)

(3) MSL, Peak Temp. - The Moisture Sensitivity Level rating according to the JEDEC industry standard classifications, and peak solder temperature.

(4) There may be additional marking, which relates to the logo, the lot trace code information, or the environmental category on the device.

(5) Multiple Device Markings will be inside parentheses. Only one Device Marking contained in parentheses and separated by a "~" will appear on a device. If a line is indented then it is a continuation of the previous line and the two combined represent the entire Device Marking for that device.

(6) Lead/Ball Finish - Orderable Devices may have multiple material finish options. Finish options are separated by a vertical ruled line. Lead/Ball Finish values may wrap to two lines if the finish value exceeds the maximum column width.

**Important Information and Disclaimer:** The information provided on this page represents TI's knowledge and belief as of the date that it is provided. TI bases its knowledge and belief on information provided by third parties, and makes no representation or warranty as to the accuracy of such information. Efforts are underway to better integrate information from third parties. TI has taken and continues to take reasonable steps to provide representative and accurate information but may not have conducted destructive testing or chemical analysis on incoming materials and chemicals. TI and TI suppliers consider certain information to be proprietary, and thus CAS numbers and other limited information may not be available for release.

In no event shall TI's liability arising out of such information exceed the total purchase price of the TI part(s) at issue in this document sold by TI to Customer on an annual basis.



**TAPE AND REEL INFORMATION**

**QUADRANT ASSIGNMENTS FOR PIN 1 ORIENTATION IN TAPE**

\*All dimensions are nominal

Device	Package Type	Package Drawing	Pins	SPQ	Reel Diameter (mm)	Reel Width W1 (mm)	A0 (mm)	B0 (mm)	K0 (mm)	P1 (mm)	W (mm)	Pin1 Quadrant
TXS0206YFPR	DSBGA	YFP	20	3000	180.0	8.4	1.66	2.06	0.56	4.0	8.0	Q1

**TAPE AND REEL BOX DIMENSIONS**



\*All dimensions are nominal

Device	Package Type	Package Drawing	Pins	SPQ	Length (mm)	Width (mm)	Height (mm)
TXS0206YFPR	DSBGA	YFP	20	3000	182.0	182.0	20.0

YFP0020

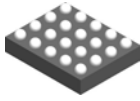

PACKAGE OUTLINE

DSBGA - 0.5 mm max height

DIE SIZE BALL GRID ARRAY

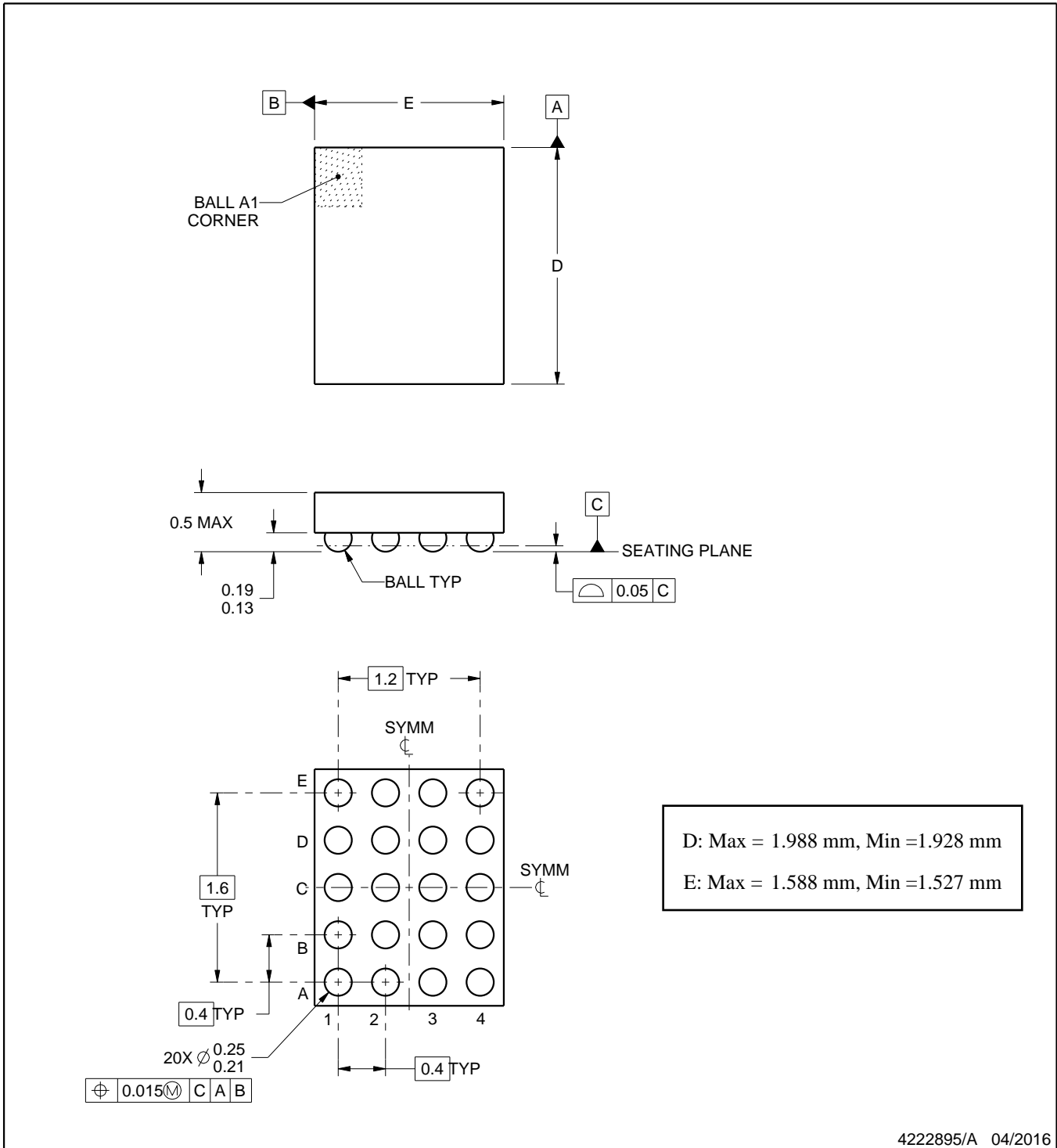

4222895/A 04/2016

NOTES:

1. All linear dimensions are in millimeters. Any dimensions in parenthesis are for reference only. Dimensioning and tolerancing per ASME Y14.5M.
2. This drawing is subject to change without notice.

# EXAMPLE BOARD LAYOUT

YFP0020

DSBGA - 0.5 mm max height

DIE SIZE BALL GRID ARRAY

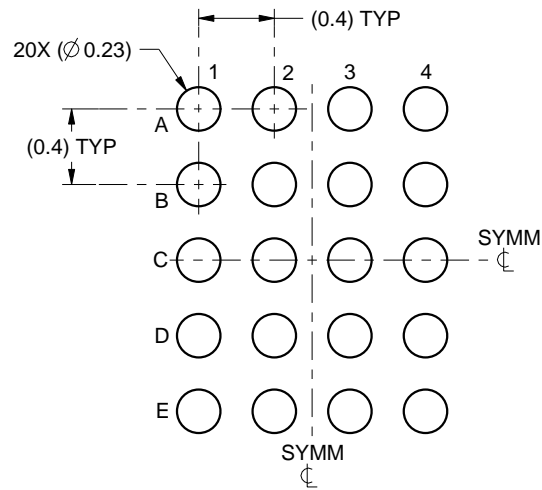

LAND PATTERN EXAMPLE  
SCALE:25X

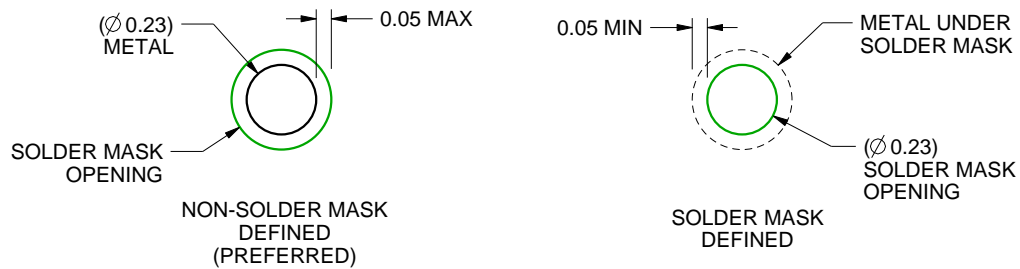

SOLDER MASK DETAILS  
NOT TO SCALE

4222895/A 04/2016

NOTES: (continued)

- Final dimensions may vary due to manufacturing tolerance considerations and also routing constraints. For more information, see Texas Instruments literature number SNVA009 ([www.ti.com/lit/snva009](http://www.ti.com/lit/snva009)).

# EXAMPLE STENCIL DESIGN

YFP0020

DSBGA - 0.5 mm max height

DIE SIZE BALL GRID ARRAY

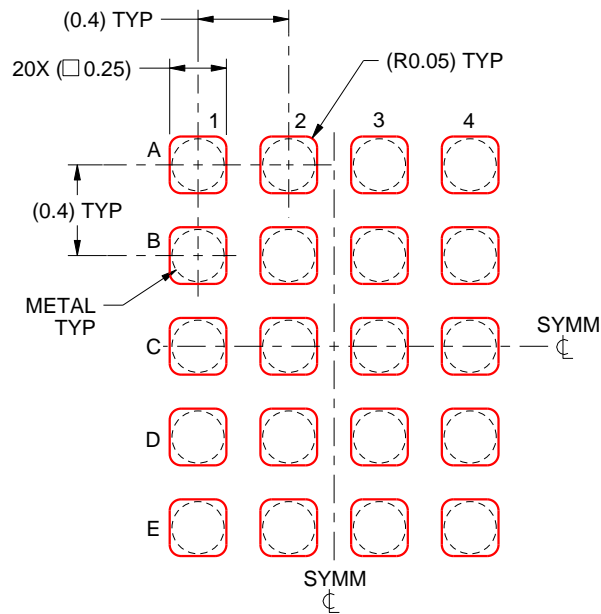

SOLDER PASTE EXAMPLE  
BASED ON 0.1 mm THICK STENCIL  
SCALE:30X

4222895/A 04/2016

NOTES: (continued)

4. Laser cutting apertures with trapezoidal walls and rounded corners may offer better paste release.

## IMPORTANT NOTICE

Texas Instruments Incorporated (TI) reserves the right to make corrections, enhancements, improvements and other changes to its semiconductor products and services per JESD46, latest issue, and to discontinue any product or service per JESD48, latest issue. Buyers should obtain the latest relevant information before placing orders and should verify that such information is current and complete.

TI's published terms of sale for semiconductor products (<http://www.ti.com/sc/docs/stdterms.htm>) apply to the sale of packaged integrated circuit products that TI has qualified and released to market. Additional terms may apply to the use or sale of other types of TI products and services.

Reproduction of significant portions of TI information in TI data sheets is permissible only if reproduction is without alteration and is accompanied by all associated warranties, conditions, limitations, and notices. TI is not responsible or liable for such reproduced documentation. Information of third parties may be subject to additional restrictions. Resale of TI products or services with statements different from or beyond the parameters stated by TI for that product or service voids all express and any implied warranties for the associated TI product or service and is an unfair and deceptive business practice. TI is not responsible or liable for any such statements.

Buyers and others who are developing systems that incorporate TI products (collectively, "Designers") understand and agree that Designers remain responsible for using their independent analysis, evaluation and judgment in designing their applications and that Designers have full and exclusive responsibility to assure the safety of Designers' applications and compliance of their applications (and of all TI products used in or for Designers' applications) with all applicable regulations, laws and other applicable requirements. Designer represents that, with respect to their applications, Designer has all the necessary expertise to create and implement safeguards that (1) anticipate dangerous consequences of failures, (2) monitor failures and their consequences, and (3) lessen the likelihood of failures that might cause harm and take appropriate actions. Designer agrees that prior to using or distributing any applications that include TI products, Designer will thoroughly test such applications and the functionality of such TI products as used in such applications.

TI's provision of technical, application or other design advice, quality characterization, reliability data or other services or information, including, but not limited to, reference designs and materials relating to evaluation modules, (collectively, "TI Resources") are intended to assist designers who are developing applications that incorporate TI products; by downloading, accessing or using TI Resources in any way, Designer (individually or, if Designer is acting on behalf of a company, Designer's company) agrees to use any particular TI Resource solely for this purpose and subject to the terms of this Notice.

TI's provision of TI Resources does not expand or otherwise alter TI's applicable published warranties or warranty disclaimers for TI products, and no additional obligations or liabilities arise from TI providing such TI Resources. TI reserves the right to make corrections, enhancements, improvements and other changes to its TI Resources. TI has not conducted any testing other than that specifically described in the published documentation for a particular TI Resource.

Designer is authorized to use, copy and modify any individual TI Resource only in connection with the development of applications that include the TI product(s) identified in such TI Resource. NO OTHER LICENSE, EXPRESS OR IMPLIED, BY ESTOPPEL OR OTHERWISE TO ANY OTHER TI INTELLECTUAL PROPERTY RIGHT, AND NO LICENSE TO ANY TECHNOLOGY OR INTELLECTUAL PROPERTY RIGHT OF TI OR ANY THIRD PARTY IS GRANTED HEREIN, including but not limited to any patent right, copyright, mask work right, or other intellectual property right relating to any combination, machine, or process in which TI products or services are used. Information regarding or referencing third-party products or services does not constitute a license to use such products or services, or a warranty or endorsement thereof. Use of TI Resources may require a license from a third party under the patents or other intellectual property of the third party, or a license from TI under the patents or other intellectual property of TI.

TI RESOURCES ARE PROVIDED "AS IS" AND WITH ALL FAULTS. TI DISCLAIMS ALL OTHER WARRANTIES OR REPRESENTATIONS, EXPRESS OR IMPLIED, REGARDING RESOURCES OR USE THEREOF, INCLUDING BUT NOT LIMITED TO ACCURACY OR COMPLETENESS, TITLE, ANY EPIDEMIC FAILURE WARRANTY AND ANY IMPLIED WARRANTIES OF MERCHANTABILITY, FITNESS FOR A PARTICULAR PURPOSE, AND NON-INFRINGEMENT OF ANY THIRD PARTY INTELLECTUAL PROPERTY RIGHTS. TI SHALL NOT BE LIABLE FOR AND SHALL NOT DEFEND OR INDEMNIFY DESIGNER AGAINST ANY CLAIM, INCLUDING BUT NOT LIMITED TO ANY INFRINGEMENT CLAIM THAT RELATES TO OR IS BASED ON ANY COMBINATION OF PRODUCTS EVEN IF DESCRIBED IN TI RESOURCES OR OTHERWISE. IN NO EVENT SHALL TI BE LIABLE FOR ANY ACTUAL, DIRECT, SPECIAL, COLLATERAL, INDIRECT, PUNITIVE, INCIDENTAL, CONSEQUENTIAL OR EXEMPLARY DAMAGES IN CONNECTION WITH OR ARISING OUT OF TI RESOURCES OR USE THEREOF, AND REGARDLESS OF WHETHER TI HAS BEEN ADVISED OF THE POSSIBILITY OF SUCH DAMAGES.

Unless TI has explicitly designated an individual product as meeting the requirements of a particular industry standard (e.g., ISO/TS 16949 and ISO 26262), TI is not responsible for any failure to meet such industry standard requirements.

Where TI specifically promotes products as facilitating functional safety or as compliant with industry functional safety standards, such products are intended to help enable customers to design and create their own applications that meet applicable functional safety standards and requirements. Using products in an application does not by itself establish any safety features in the application. Designers must ensure compliance with safety-related requirements and standards applicable to their applications. Designer may not use any TI products in life-critical medical equipment unless authorized officers of the parties have executed a special contract specifically governing such use. Life-critical medical equipment is medical equipment where failure of such equipment would cause serious bodily injury or death (e.g., life support, pacemakers, defibrillators, heart pumps, neurostimulators, and implantables). Such equipment includes, without limitation, all medical devices identified by the U.S. Food and Drug Administration as Class III devices and equivalent classifications outside the U.S.

TI may expressly designate certain products as completing a particular qualification (e.g., Q100, Military Grade, or Enhanced Product). Designers agree that it has the necessary expertise to select the product with the appropriate qualification designation for their applications and that proper product selection is at Designers' own risk. Designers are solely responsible for compliance with all legal and regulatory requirements in connection with such selection.

Designer will fully indemnify TI and its representatives against any damages, costs, losses, and/or liabilities arising out of Designer's non-compliance with the terms and provisions of this Notice.

## Looking for pricing, stock, or lifecycle information?

Click below to explore more details on WIN SOURCE:

 [View TXS0206YFPR on WIN SOURCE](#)

 [Texas Instruments](#) Information

## Optimize Your Supply Chain with WIN SOURCE Solutions

-  Global Sourcing Solution
-  Obsolete Management
-  Cost Control Management
-  Shortage Management
-  Alternative Solution
-  Excess Inventory Management