

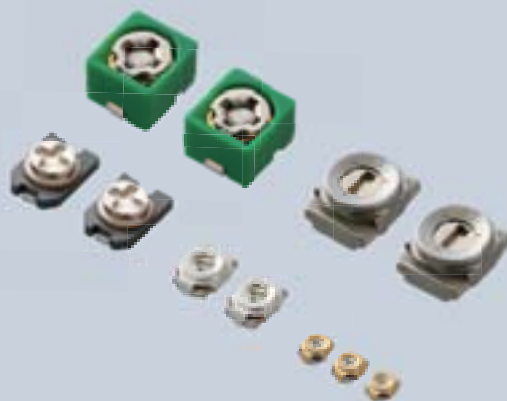

**THE DATASHEET OF
TZVY2Z060A110T00**



Ceramic Trimmer Capacitors





EU RoHS Compliant

- All the products in this catalog comply with EU RoHS.
- EU RoHS is "the European Directive 2011/65/EU on the Restriction of the Use of Certain Hazardous Substances in Electrical and Electronic Equipment."
- For more details, please refer to our web page, "Murata's Approach for EU RoHS" (<http://www.murata.com/en-eu/support/compliance/rohs>).

Contents

Product specifications are as of September 2017.

Bluetooth® is a registered trademark
or trademark of Bluetooth SIG, Inc.
in the United States and other countries.

| | |
|---|-----|
| Part Numbering | p2 |
| Selection Guide of Ceramic Trimmer Capacitors ... | p3 |
| <hr/> | |
| 1 TZR1 Series | p4 |
| <hr/> | |
| 2 TZY2 Series | p8 |
| <hr/> | |
| 3 TZC3 Series | p13 |
| <hr/> | |
| 4 TZW4 Series | p18 |
| <hr/> | |
| 5 TZB4 Series | p21 |
| <hr/> | |
| Packaging | p26 |
| Recommended Adjustment Tools | p28 |
| Qualified Standards | p29 |

Please check the MURATA website (<http://www.murata.com/>)
if you cannot find a part number in this catalog.

● Part Numbering

Ceramic Trimmer Capacitors

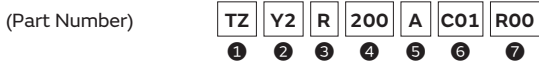

① Product ID

| Product ID | |
|------------|--------------------|
| TZ | Trimmer Capacitors |

② Series/Terminal

| Code | Series/Terminal |
|------|-------------------|
| B4 | 4mm Size SMD Type |
| W4 | 4mm Size SMD Type |
| C3 | 3mm Size SMD Type |
| Y2 | 2mm Size SMD Type |
| R1 | 1mm Size SMD Type |

③ Temperature Characteristics

| Code | Temperature Characteristics |
|------|-----------------------------|
| Z | NP0ppm/°C |
| R | N750ppm/°C |
| K | N1000ppm/°C |
| P | N1200ppm/°C |

Please refer to ratings for tolerance of temperature characteristics.

④ Maximum Capacitance

Expressed by three-digit alphanumerics. The unit is pico-farad (pF). The first and second figures are significant digits, and the third figure expresses the number of zeros that follow the two numbers. If there is a decimal point, it is expressed by the capital letter "R". In this case, all figures are significant digits.

⑤ Terminal Shape

| Code | Terminal Shape |
|------|--|
| A | Top Adjustment: TZR1, TZY2, TZC3, TZW4, TTB4 |
| B | Top Adjustment: TTB4 |

Please refer to dimensions for terminal details.

⑥ Individual Specifications

| Code | Individual Specifications |
|------|------------------------------------|
| 001 | TZR1, TZW4 Standard Type |
| C01 | TZY2 Standard Type |
| A01 | TZC3 Standard Type |
| A10 | TTB4 No-cover Film Standard Type |
| B10 | TTB4 with Cover Film Standard Type |

⑦ Packaging

| Code | Packaging |
|------|----------------------|
| B00 | Bulk |
| R00 | Reel (Taping ø180mm) |
| R01* | Reel (Taping ø330mm) |

* TTB4 only.

Selection Guide

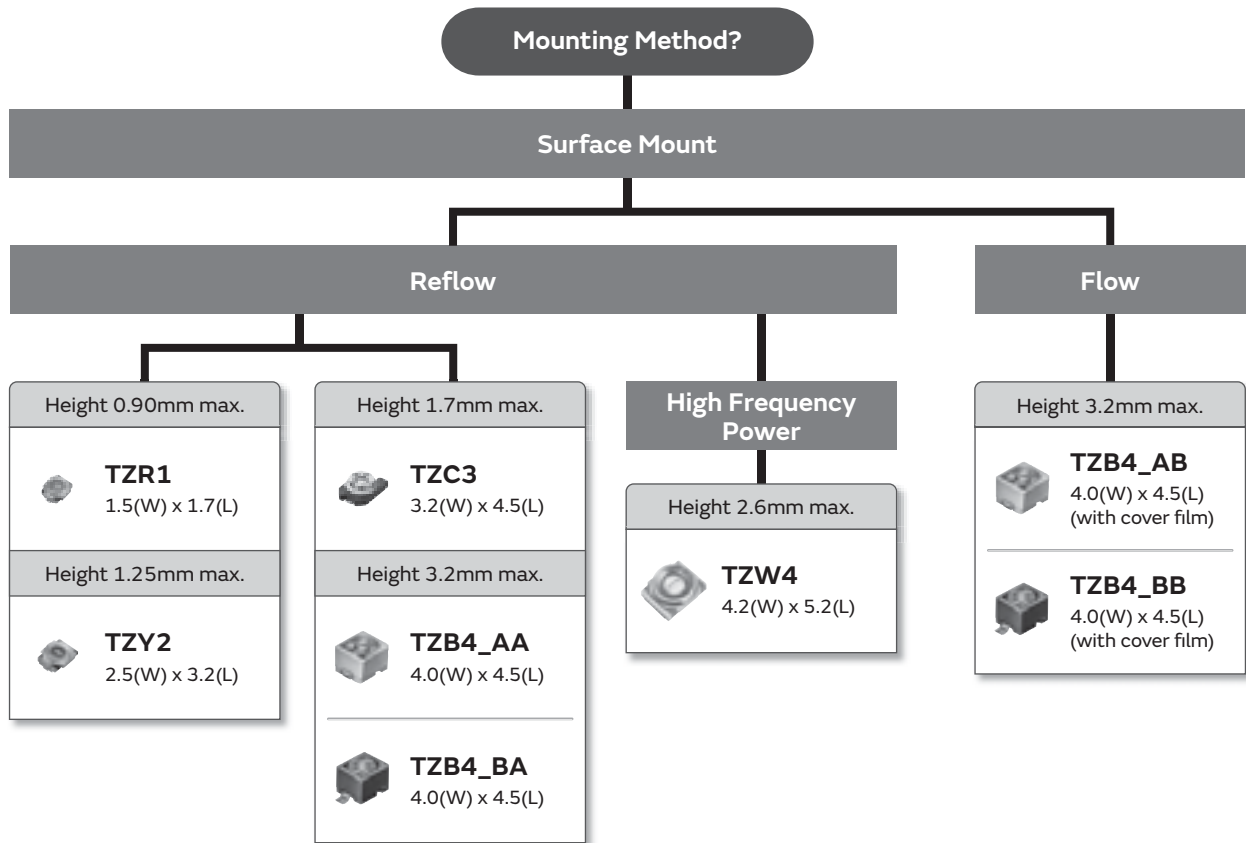

All Ceramic Trimmer Capacitor products comply with RoHS and ELV.

Ceramic Trimmer Capacitors

TZR1 Series

Features

1. Ultra-small and thin with external dimensions of 1.5(W)x1.7(L)x0.85(H)mm (80% less in volume than the current product).
2. Unique construction with no plastic material provides superior soldering heat resistance to maintain excellent characteristic performance after reflow soldering.
3. Suitable for high frequency circuit due to high self-resonant frequency (6.2GHz of TZR1Z010 at 1.0pF setting).

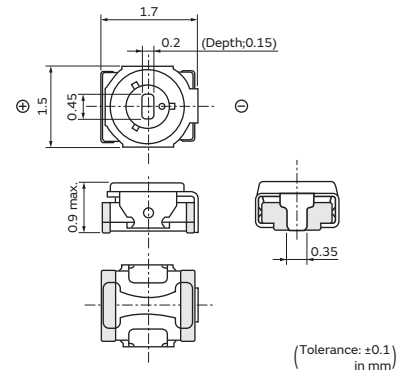

Applications

1. Bluetooth®
2. Crystal oscillators
3. Crystal filters
4. Miniature tuner packs (FM Radio, TV)
5. Remote keyless entry systems

| Part Number | C min. (max.) (pF) | C max. (pF) | TC | Q | Rated Voltage | Withstanding Voltage |
|--------------|--------------------|--------------|----------------|--------------------------|---------------|----------------------|
| TZR1Z010A001 | 0.55 | 1.0 +100/-0% | NP0±300ppm/°C | 200min. at 200MHz, Cmax. | 25Vdc | 55Vdc |
| TZR1Z1R5A001 | 0.7 | 1.5 +100/-0% | NP0±300ppm/°C | 200min. at 200MHz, Cmax. | 25Vdc | 55Vdc |
| TZR1Z040A001 | 1.5 | 4.0 +100/-0% | NP0±500ppm/°C | 300min. at 1MHz, Cmax. | 25Vdc | 55Vdc |
| TZR1R080A001 | 3.0 | 8.0 +100/-0% | N750±500ppm/°C | 300min. at 1MHz, Cmax. | 25Vdc | 55Vdc |

Insulation Resistance: 10000M ohm Torque: 0.1 to 1.0mNm Operating Temperature Range: -25 to +85°C

Construction

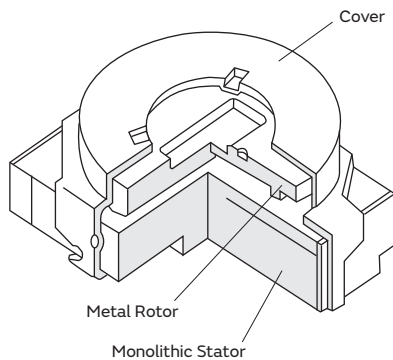

Temperature Characteristics

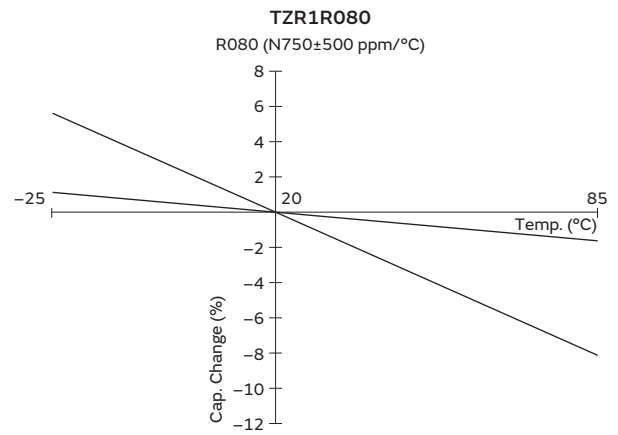
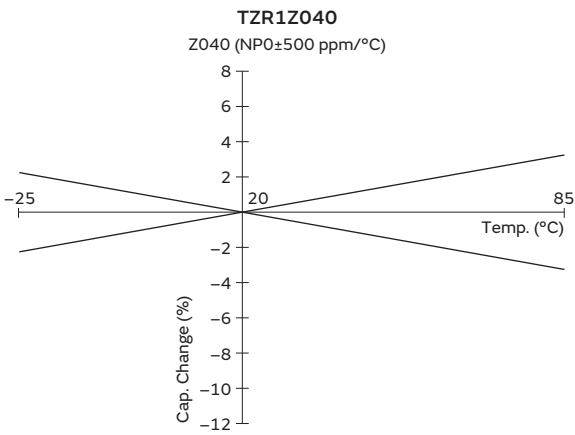
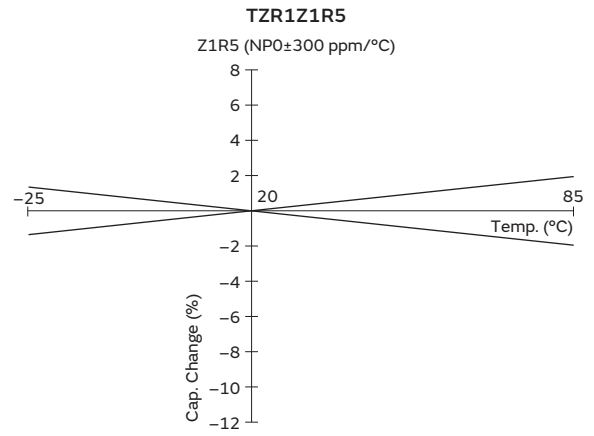
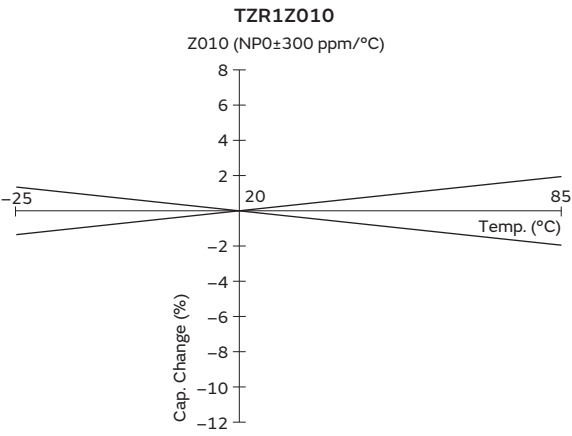

Frequency Characteristics

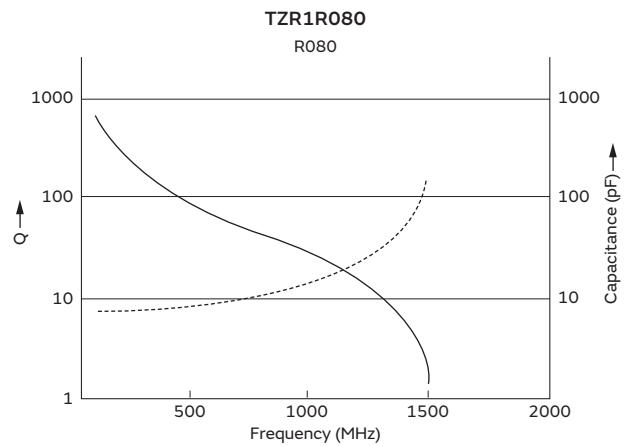
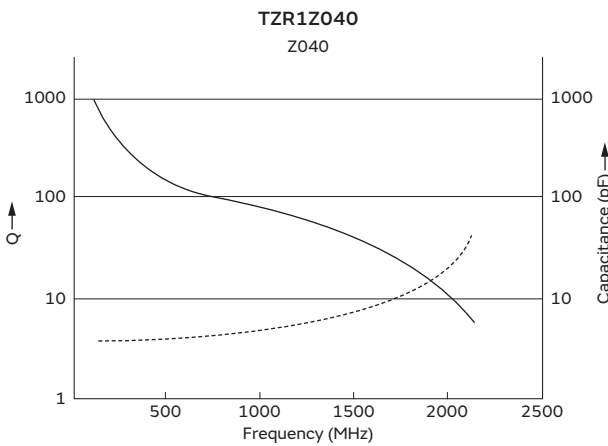
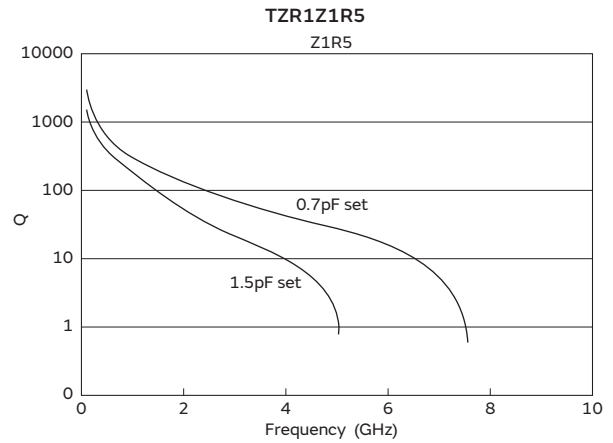
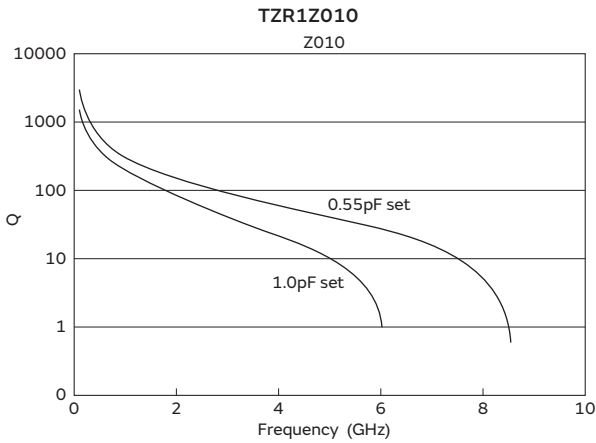

Land Pattern

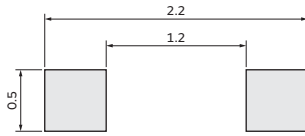

(Tolerance: ±0.1 in mm)

Temperature Profile

● **Reflow Soldering Profile**

① Soldering profile for Lead-free solder (96.5Sn/3Ag/0.5Cu)

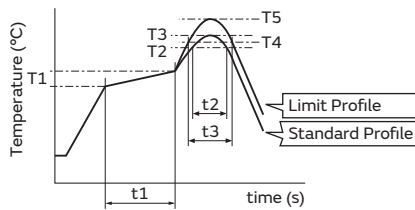

| Standard Profile | | | | | |
|------------------|---------------|------------|--------------|-----------------------|-----------------|
| Pre-heating | | Heating | | Peak temperature (T3) | Cycle of reflow |
| Temp. (T1) | Time (t1) | Temp. (T2) | Time (t2) | | |
| 150 to 180°C | 60 to 120sec. | 220°C | 30 to 60sec. | 245±3°C | 2 times |

| Limit Profile | | | | | |
|---------------|---------------|------------|--------------|-----------------------|-----------------|
| Pre-heating | | Heating | | Peak temperature (T5) | Cycle of reflow |
| Temp. (T1) | Time (t1) | Temp. (T4) | Time (t3) | | |
| 150 to 180°C | 60 to 120sec. | 230°C | 30 to 50sec. | 260 +5/-0°C | 2 times |

② Soldering profile for Eutectic solder (63Sn/37Pb)

(Limit profile: refer to ①)

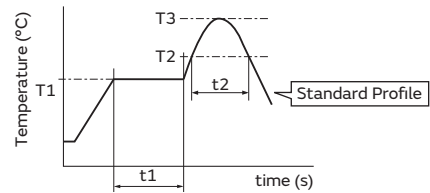

| Standard Profile | | | | | |
|------------------|---------------|------------|-----------|-----------------------|-----------------|
| Pre-heating | | Heating | | Peak temperature (T3) | Cycle of reflow |
| Temp. (T1) | Time (t1) | Temp. (T2) | Time (t2) | | |
| 150°C | 60 to 120sec. | 183°C | 30sec. | 230 +5/-0°C | 1 time |

● **Soldering Iron**

| Standard Profile | | | |
|-----------------------------------|----------------|-----------------------------|-------------------------|
| Temperature of soldering iron tip | Soldering time | Soldering iron power output | Cycle of soldering iron |
| 350±10°C | 3sec. max. | 30W max. | 1 time |

Notice (Storage and Operating Conditions)

- Do not use the trimmer capacitor under atmosphere of RTV silicone rubber (Room Temperature Vulcanizing Silicone Rubber) except Acetone liberating silicone sealant.
- Before using trimmer capacitors, please store under the conditions of -10 to +40°C and 30 to 85%RH.
- Do not store in or near corrosive gasses.
- Use within 6 months of delivery.
- Do not store under direct sunlight.
- Do not use the trimmer capacitor under the conditions listed below.
 - Corrosive gasses atmosphere (ex. Chlorine gas, Hydrogen sulfide gas, Ammonia gas, Sulfuric acid gas, Nitric oxide gas, etc.)
 - In liquid (ex. water, oil, medical liquid, organic solvent, etc.)
 - Dusty / dirty atmosphere
 - Direct sunlight
 - Static voltage or electric/magnetic fields
 - Direct sea breeze
 - Other variations of the above

Notice (Soldering and Mounting)

1. Soldering

- (1) TZR1 series can be soldered by reflow soldering method and soldering iron. Do not use flow soldering method (dipping).
- (2) Soldering conditions
Refer to the temperature profile.
If the soldering conditions are not suitable, e.g., excessive time and/or excessive temperature, the trimmer capacitor may deviate from the specified characteristics.
- (3) The amount of solder is critical.
- (4) The thickness of solder paste should be printed from 100 micro m to 150 micro m and the dimension of land pattern should be Murata's standard land pattern used at reflow soldering.
Insufficient amounts of solder can lead to insufficient soldering strength on PCB.
Excessive amounts of solder may cause bridging between the terminals or contact failure due to flux wicking up.
- (5) When using soldering iron, the diameter of the string solder shall be less than 0.5mm. The string solder shall be applied to the lower part of the terminal only. Do not apply flux except to the terminals. Excessive amounts of solder and/or applying solder to the upper part of the terminal may cause fixed metal rotor or contact failure due to flux invasion into the movable part and/or the contact point. The soldering iron should not come in contact with the monolithic stator of the trimmer capacitor. If such contact does occur, the trimmer capacitor may be damaged.

(6) Our recommended chlorine content of solder is as follows.

- (a) Solder paste: 0.2wt% max.
- (b) String solder: 0.5wt% max.
- (7) Do not use water-soluble flux (for water cleaning). To prevent the deterioration of trimmer capacitor characteristics, apply flux only to terminals.

2. Mounting

- (1) Do not apply excessive force (preferably 5.0 N [Ref: 500gf] max.), when the trimmer capacitor is mounted on the PCB.
- (2) Do not warp and/or bend PCB to protect trimmer capacitor from breaking.
- (3) Use a pick-up nozzle of a suitable dimension. (1.6mm external diameter and 0.8mm bore diameter.)

3. Cleaning

This product cannot be cleaned because of open construction.

4. Other

Note the polarity of the trimmer capacitor to minimize influence by stray capacitance.
(Refer to the dimensions concerning the polarity.)

Notice (Handling)

1. Use suitable screwdrivers that fit comfortably in driver slot.
*Recommended screwdriver for manual adjustment
MURATA: KMDR160
2. When adjusting with a screwdriver, do not apply excessive force (preferably 0.5 N [Ref: 50gf] max.) to minimize capacitance drift. Excessive force applied to the screwdriver slot may cause deformation of the products.

3. Do not apply adhesive, lock paints, or any other substances to the trimmer capacitor to secure the rotor position. They may cause corrosion or electrical contact problems.

Notice (Other)

Before using trimmer capacitors, please test after assembly in your particular mass production system.

Ceramic Trimmer Capacitors

TZY2 Series

2

Features

1. Small and thin size with external dimensions of 2.5(W)x3.2(L)x1.25max.(H)mm.
2. New shape of cover can improve the flux invasion compared with current products.
3. Improvement of the adhesion between rotor and stator leads to superior stability.
4. Unique construction with no plastic material provides superior soldering heat resistance to maintain excellent characteristic performance after reflow soldering.
5. Suitable for high frequency circuit due to high self-resonant frequency (4.8GHz of TZY2Z010 at 1.0pF setting).

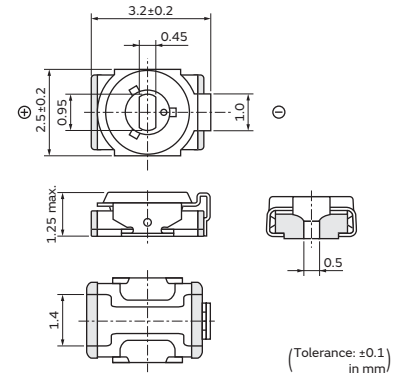

Applications

1. Crystal oscillators
2. Crystal filters
3. Stylus pen
4. Hand radios
5. Watches
6. Remote keyless entry systems
7. W-LAN
8. Radar detectors
9. Compact radios
10. Burglarproof devices
11. Headphone stereos

| Part Number | C min. (max.) (pF) | C max. (pF) | TC | Q | Rated Voltage | Withstanding Voltage |
|--------------|--------------------|---------------|-----------------|--------------------------|---------------|----------------------|
| TZY2Z010AC01 | 0.6 | 1.0 +100/-0% | NP0±300ppm/°C | 200min. at 200MHz, Cmax. | 25Vdc | 55Vdc |
| TZY2Z2R5AC01 | 1.0 | 2.5 +100/-0% | NP0±300ppm/°C | 200min. at 200MHz, Cmax. | 25Vdc | 55Vdc |
| TZY2Z030AC01 | 1.5 | 3.0 +100/-0% | NP0±300ppm/°C | 300min. at 1MHz, Cmax. | 25Vdc | 55Vdc |
| TZY2Z060AC01 | 2.5 | 6.0 +100/-0% | NP0±300ppm/°C | 500min. at 1MHz, Cmax. | 25Vdc | 55Vdc |
| TZY2Z100AC01 | 3.0 | 10.0 +100/-0% | NP0±300ppm/°C | 500min. at 1MHz, Cmax. | 25Vdc | 55Vdc |
| TZY2R200AC01 | 4.5 | 20.0 +100/-0% | N750±500ppm/°C | 500min. at 1MHz, Cmax. | 25Vdc | 55Vdc |
| TZY2R250AC01 | 5.5 | 25.0 +100/-0% | N750±500ppm/°C | 300min. at 1MHz, Cmax. | 25Vdc | 55Vdc |
| TZY2K450AC01 | 8.0 | 45.0 +100/-0% | N1000±500ppm/°C | 300min. at 1MHz, Cmax. | 25Vdc | 55Vdc |

Insulation Resistance: 10000M ohm Torque: 0.7 to 4.9mNm Operating Temperature Range: -25 to +85°C

Construction

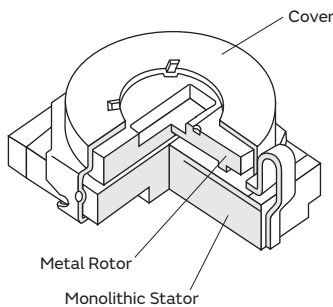

Temperature Characteristics

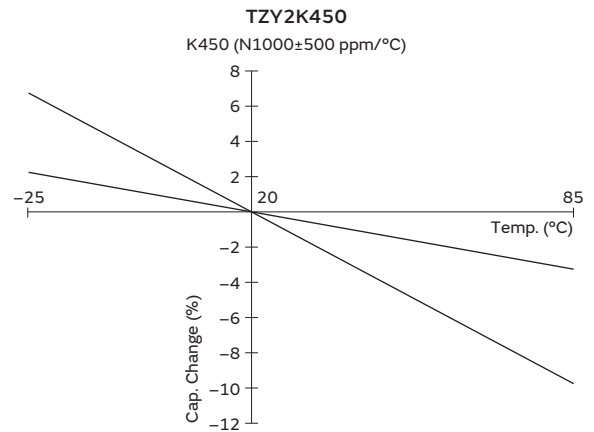
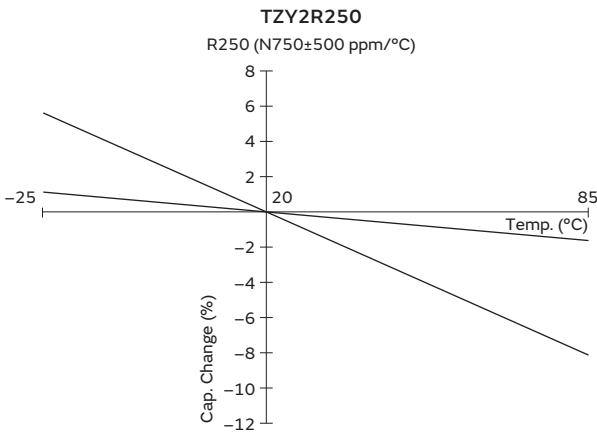
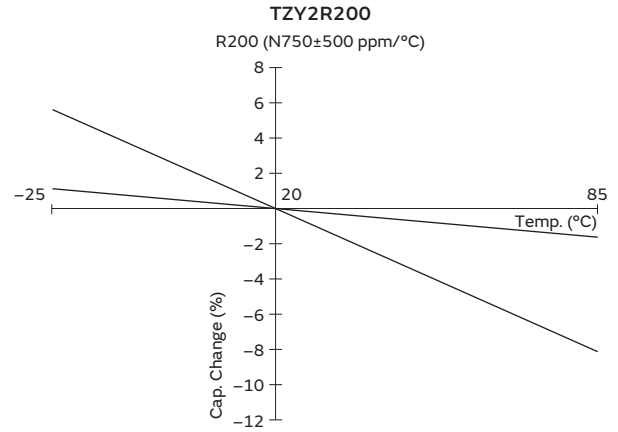
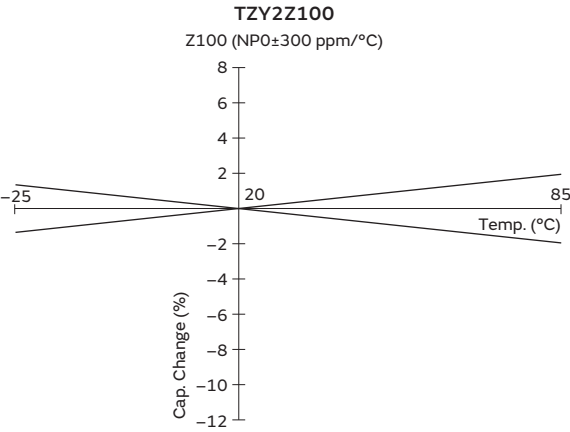
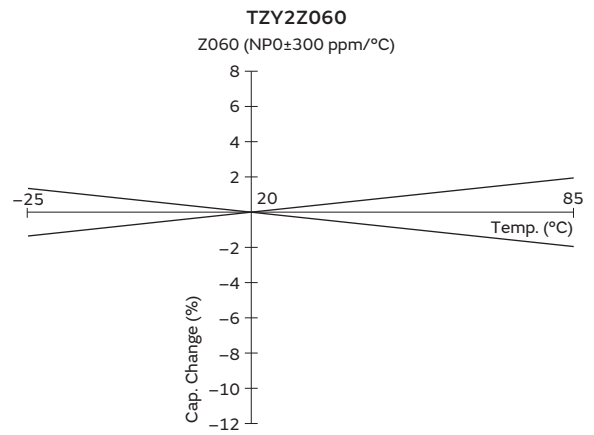
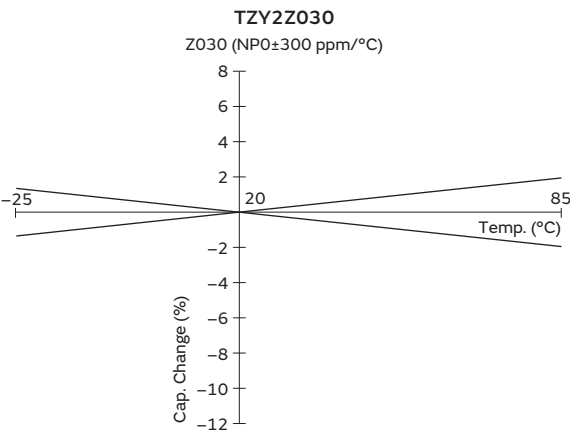
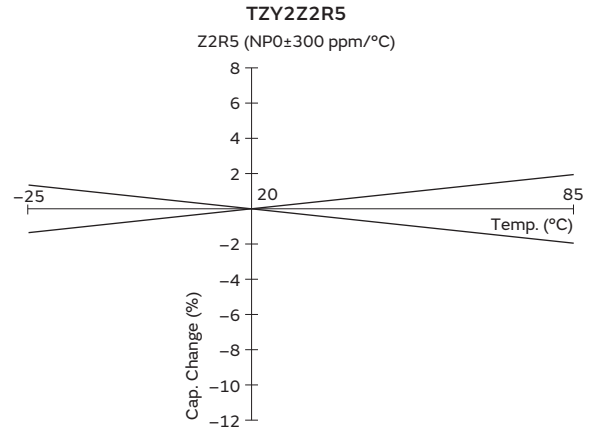
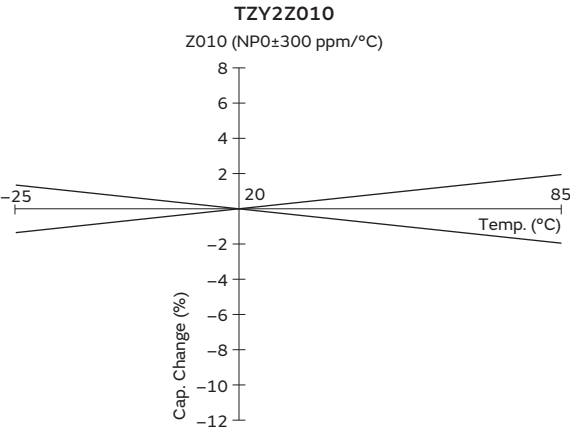

2

9

Frequency Characteristics

2

TZY2Z010
 Z010

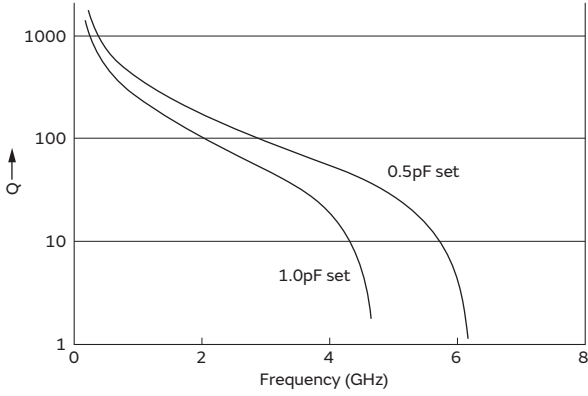

TZY2Z100
 Z100

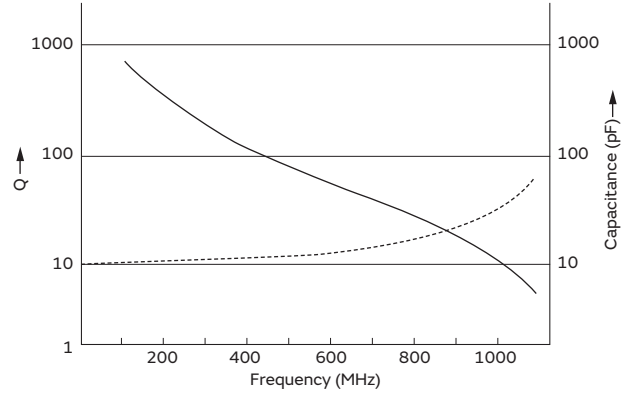

TZY2R200
 R200

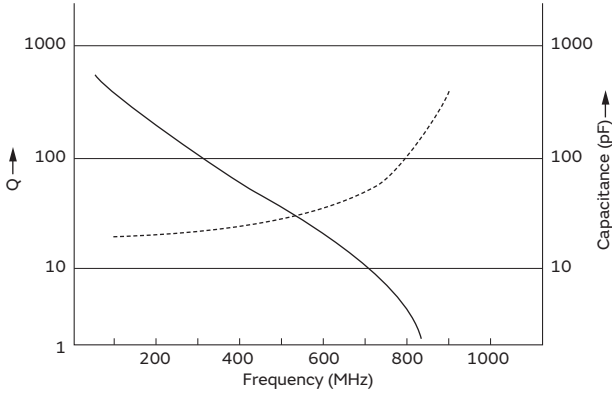

TZY2K450
 K450

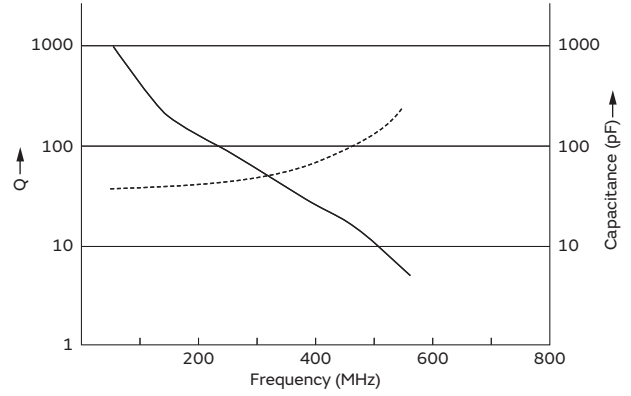

Land Pattern

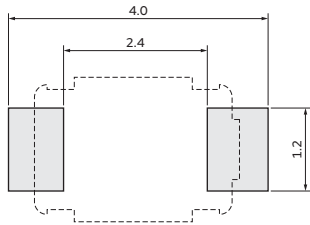

(Tolerance: ±0.1
 in mm)

Temperature Profile

●Reflow Soldering Profile

①Soldering profile for Lead-free solder (96.5Sn/3Ag/0.5Cu)

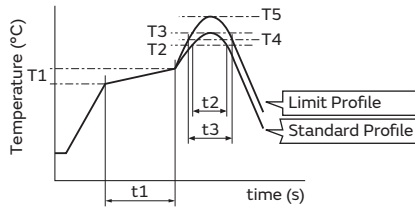

| Standard Profile | | | | | |
|------------------|---------------|------------|--------------|-----------------------|-----------------|
| Pre-heating | | Heating | | Peak temperature (T3) | Cycle of reflow |
| Temp. (T1) | Time (t1) | Temp. (T2) | Time (t2) | | |
| 150 to 180°C | 60 to 120sec. | 220°C | 30 to 60sec. | 245±3°C | 2 times |

| Limit Profile | | | | | |
|---------------|---------------|------------|--------------|-----------------------|-----------------|
| Pre-heating | | Heating | | Peak temperature (T5) | Cycle of reflow |
| Temp. (T1) | Time (t1) | Temp. (T4) | Time (t3) | | |
| 150 to 180°C | 60 to 120sec. | 230°C | 30 to 50sec. | 260 +5/-0°C | 2 times |

②Soldering profile for Eutectic solder (63Sn/37Pb)

(Limit profile: refer to ①)

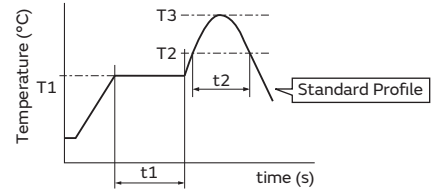

| Standard Profile | | | | | |
|------------------|---------------|------------|-----------|-----------------------|-----------------|
| Pre-heating | | Heating | | Peak temperature (T3) | Cycle of reflow |
| Temp. (T1) | Time (t1) | Temp. (T2) | Time (t2) | | |
| 150°C | 60 to 120sec. | 183°C | 30sec. | 230 +5/-0°C | 1 time |

●Soldering Iron

| Standard Profile | | | |
|-----------------------------------|----------------|-----------------------------|-------------------------|
| Temperature of soldering iron tip | Soldering time | Soldering iron power output | Cycle of soldering iron |
| 350±10°C | 3sec. max. | 30W max. | 1 time |

Notice (Storage and Operating Conditions)

- Do not use the trimmer capacitor under atmosphere of RTV silicone rubber (Room Temperature Vulcanizing Silicone Rubber) except Acetone liberating silicone sealant.
- Before using trimmer capacitors, please store under the conditions of -10 to +40°C and 30 to 85%RH.
- Do not store in or near corrosive gasses.
- Use within 6 months of delivery.
- Do not store under direct sunlight.
- Do not use the trimmer capacitor under the conditions listed below.
 - Corrosive gasses atmosphere (ex. Chlorine gas, Hydrogen sulfide gas, Ammonia gas, Sulfuric acid gas, Nitric oxide gas, etc.)
 - In liquid (ex. water, oil, medical liquid, organic solvent, etc.)
 - Dusty / dirty atmosphere
 - Direct sunlight
 - Static voltage or electric/magnetic fields
 - Direct sea breeze
 - Other variations of the above

Notice (Soldering and Mounting)

1. Soldering

- (1) TZY2 series can be soldered by reflow soldering method and soldering iron. Do not use flow soldering method (dipping).
- (2) Soldering conditions
Refer to the temperature profile.
If the soldering conditions are not suitable, e.g., excessive time and/or excessive temperature, the trimmer capacitor may deviate from the specified characteristics.
- (3) The amount of solder is critical.
- (4) The thickness of solder paste should be printed from 120 micro m to 170 micro m and the dimension of land pattern should be Murata's standard land pattern used at reflow soldering.
Insufficient amounts of solder can lead to insufficient soldering strength on PCB.
Excessive amounts of solder may cause bridging between the terminals or contact failure due to flux wicking up.
- (5) When using soldering iron, the diameter of the string solder shall be less than 0.5mm. The string solder shall be applied to the lower part of the terminal only. Do not apply flux except to the terminals. Excessive amounts of solder and/or applying solder to the upper part of the terminal may cause fixed metal rotor or contact failure due to flux invasion into the movable part and/or the contact point. The soldering iron should not come in contact with the monolithic stator of the trimmer capacitor. If such contact does occur, the trimmer capacitor may be damaged.

(6) Our recommended chlorine content of solder is as follows.

- (a) Solder paste: 0.2wt% max.
 - (b) String solder: 0.5wt% max.
- (7) Do not use water-soluble flux (for water cleaning). To prevent the deterioration of trimmer capacitor characteristics, apply flux only to terminals.

2. Mounting

- (1) Do not apply excessive force (preferably 5.0 N [Ref: 500gf] max.), when the trimmer capacitor is mounted on the PCB.
- (2) Do not warp and/or bend PCB to protect trimmer capacitor from breakage.
- (3) Use a pick-up nozzle of a suitable dimension. (2.5mm external diameter and 1.2mm bore diameter.)

3. Cleaning

This product cannot be cleaned because of open construction.

4. Other

Note the polarity of the trimmer capacitor to minimize influence by stray capacitance.
(Refer to the dimensions concerning the polarity.)

Notice (Handling)

1. Use suitable screwdrivers that fit comfortably in driver slot.

- (1) Recommended screwdriver for manual adjustment
MURATA: KMDR020
- (2) Recommended screwdriver bit for automatic adjustment
MURATA: KMBT020

2. When adjusting with a screwdriver, do not apply excessive force (preferably 1.0 N [Ref: 100gf] max.) to minimize capacitance drift. Excessive force applied to the screwdriver slot may cause deformation of the products.

3. Do not apply adhesive, lock paints, or any other substances to the trimmer capacitor to secure the rotor position. They may cause corrosion or electrical contact problems.

Notice (Other)

Before using trimmer capacitor, please test after assembly in your particular mass production system.

Ceramic Trimmer Capacitors

TZC3 Series

Features

1. Small size with external dimension of 3.2(W)x4.5(L)x1.6(H)mm.
2. Can be adjusted with conventional adjustment tools having a thickness of 0.5mm.
3. Designed for automatic placement in surface mount applications.
4. Heat resistant resin withstands reflow soldering temperatures.

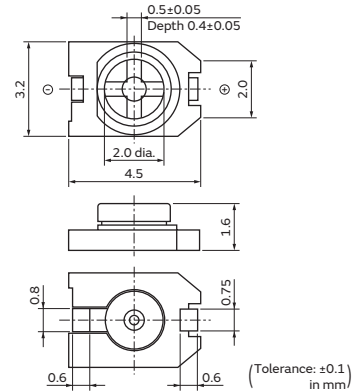

Applications

1. Compact radios
2. Stylus pen
3. Portable radio equipment
4. Hybrid ICs
5. Remote keyless entry systems

| Part Number | C min. (max.) (pF) | C max. (pF) | TC | Q | Rated Voltage | Withstanding Voltage |
|--------------|--------------------|--------------|-----------------|------------------------|---------------|----------------------|
| TZC3Z030AA01 | 1.4 | 3.0 +50/-0% | NP0±300ppm/°C | 300min. at 1MHz, Cmax. | 100Vdc | 220Vdc |
| TZC3Z060AA01 | 2.0 | 6.0 +50/-0% | NP0±300ppm/°C | 500min. at 1MHz, Cmax. | 100Vdc | 220Vdc |
| TZC3R100AA01 | 3.0 | 10.0 +50/-0% | N750±300ppm/°C | 500min. at 1MHz, Cmax. | 100Vdc | 220Vdc |
| TZC3P200AA01 | 5.0 | 20.0 +50/-0% | N1200±500ppm/°C | 300min. at 1MHz, Cmax. | 100Vdc | 220Vdc |
| TZC3P300AA01 | 6.5 | 30.0 +50/-0% | N1200±500ppm/°C | 300min. at 1MHz, Cmax. | 100Vdc | 220Vdc |

Insulation Resistance: 10000M ohm Torque: 1.5 to 9.8mNm Operating Temperature Range: -25 to +85°C

Construction

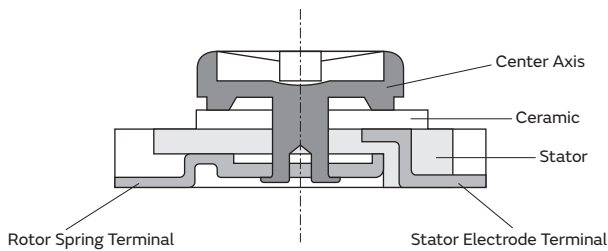

Temperature Characteristics

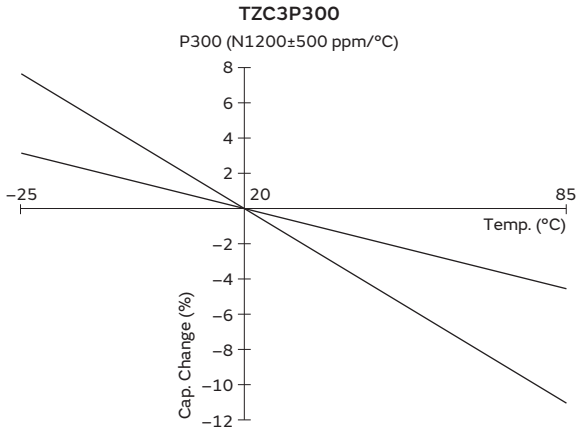
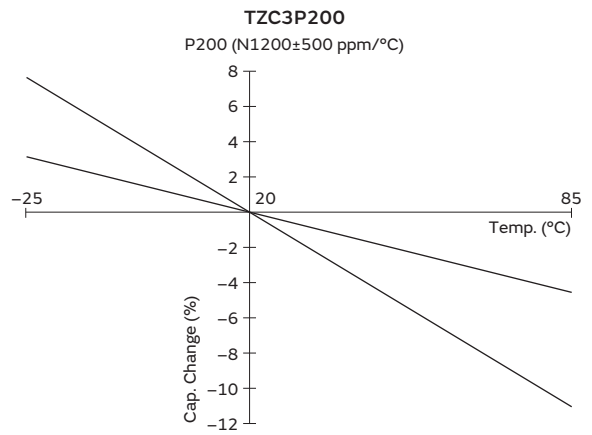
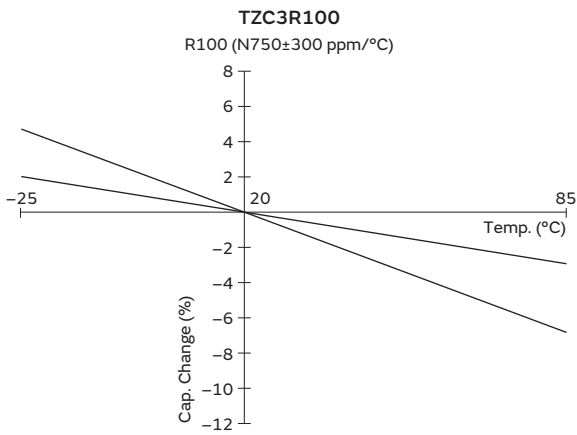
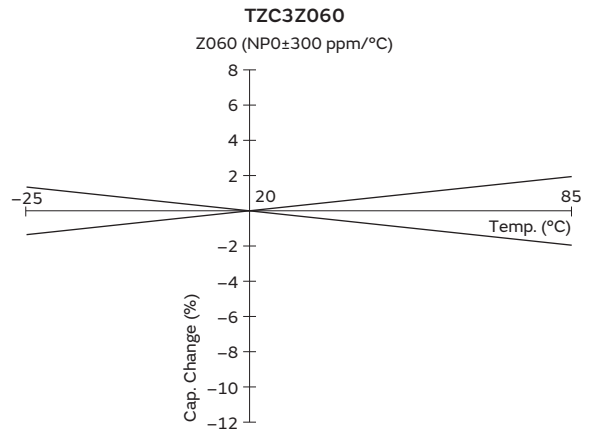
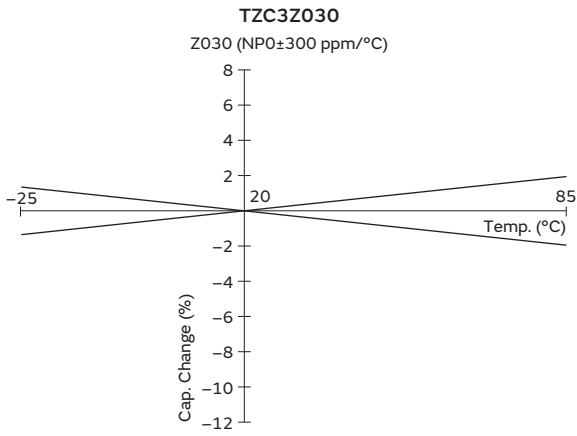

3

Frequency Characteristics

TZC3Z030
 Z030

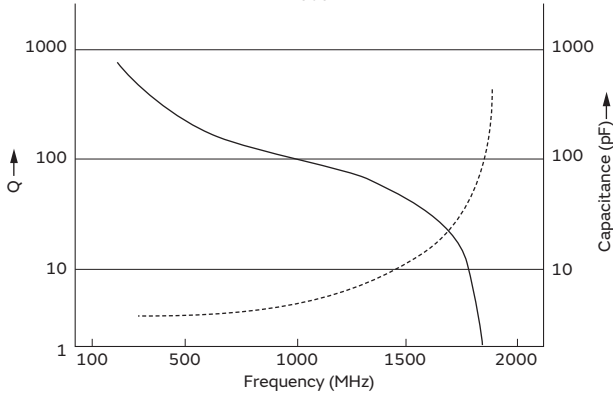

TZC3Z060
 Z060

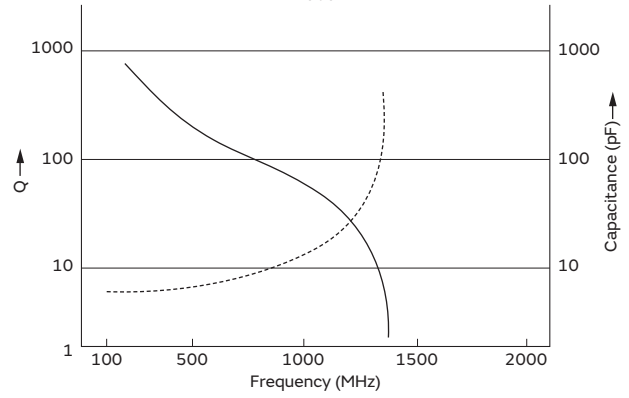

TZC3R100
 R100

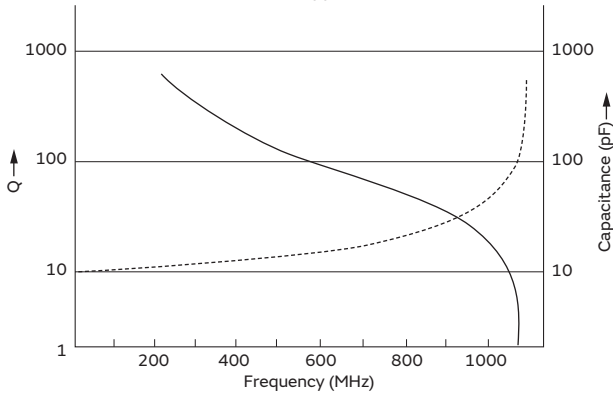

TZC3P200
 P200

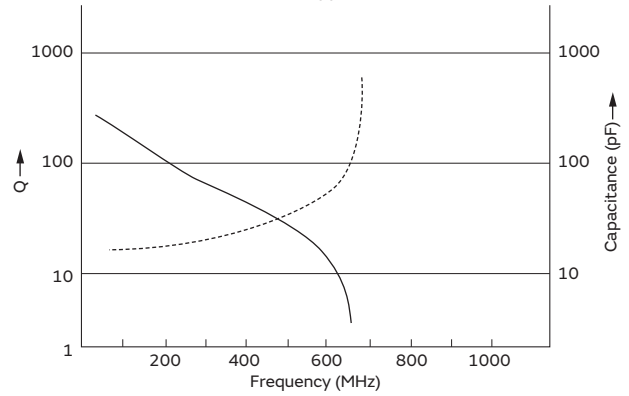

Land Pattern

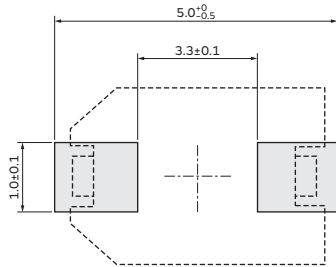

(Tolerance: ±0.1
 in mm)

3

15

Temperature Profile

●Reflow Soldering Profile

①Soldering profile for Lead-free solder (96.5Sn/3Ag/0.5Cu)

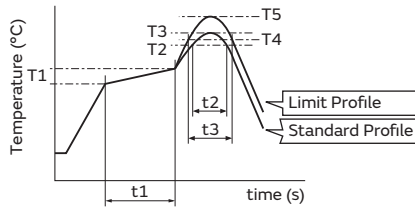

| Standard Profile | | | | | |
|------------------|---------------|------------|--------------|-----------------------|-----------------|
| Pre-heating | | Heating | | Peak temperature (T3) | Cycle of reflow |
| Temp. (T1) | Time (t1) | Temp. (T2) | Time (t2) | | |
| 150 to 180°C | 60 to 120sec. | 220°C | 30 to 60sec. | 245±3°C | 2 times |

| Limit Profile | | | | | |
|---------------|---------------|------------|--------------|-----------------------|-----------------|
| Pre-heating | | Heating | | Peak temperature (T5) | Cycle of reflow |
| Temp. (T1) | Time (t1) | Temp. (T4) | Time (t3) | | |
| 150 to 180°C | 60 to 120sec. | 230°C | 30 to 50sec. | 260 +5/-0°C | 2 times |

②Soldering profile for Eutectic solder (63Sn/37Pb)

(Limit profile: refer to ①)

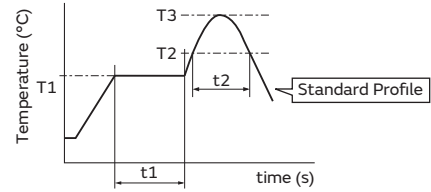

| Standard Profile | | | | | |
|------------------|---------------|------------|-----------|-----------------------|-----------------|
| Pre-heating | | Heating | | Peak temperature (T3) | Cycle of reflow |
| Temp. (T1) | Time (t1) | Temp. (T2) | Time (t2) | | |
| 150°C | 60 to 120sec. | 183°C | 30sec. | 230 +5/-0°C | 1 time |

●Soldering Iron

| Standard Profile | | | |
|-----------------------------------|----------------|-----------------------------|-------------------------|
| Temperature of soldering iron tip | Soldering time | Soldering iron power output | Cycle of soldering iron |
| 350±10°C | 3sec. max. | 30W max. | 1 time |

Notice (Storage and Operating Conditions)

- Do not use the trimmer capacitor under atmosphere of RTV silicone rubber (Room Temperature Vulcanizing Silicone Rubber) except Acetone liberating silicone sealant.
- Before using trimmer capacitors, please store under the conditions of -10 to +40°C and 30 to 85%RH.
- Do not store in or near corrosive gasses.
- Use within 6 months of delivery.
- Do not store under direct sunlight.
- Do not use the trimmer capacitor under the conditions listed below.
 - Corrosive gasses atmosphere (ex. Chlorine gas, Hydrogen sulfide gas, Ammonia gas, Sulfuric acid gas, Nitric oxide gas, etc.)
 - In liquid (ex. water, oil, medical liquid, organic solvent, etc.)
 - Dusty / dirty atmosphere
 - Direct sunlight
 - Static voltage or electric/magnetic fields
 - Direct sea breeze
 - Other variations of the above

Notice (Soldering and Mounting)

1. Soldering

- (1) TZC3 series can be soldered by reflow soldering method and soldering iron. Do not use flow soldering method (dipping).
- (2) Soldering conditions
Refer to the temperature profile.
If the soldering conditions are not suitable, e.g., excessive time and/or excessive temperature, the trimmer capacitor may deviate from the specified characteristics.
- (3) The amount of solder is critical.
- (4) The thickness of solder paste should be printed from 150 micro m to 200 micro m and the dimension of land pattern should be Murata's standard land pattern used at reflow soldering.
Insufficient amounts of solder can lead to insufficient soldering strength on PCB.
Excessive amounts of solder may cause bridging between the terminals or contact failure due to flux wicking up.
- (5) When using soldering iron, the diameter of the string solder shall be less than 0.5mm. The string solder shall be applied to the lower part of the terminal only. Do not apply flux except to the terminals. Excessive amounts of solder and/or applying solder to the upper part of the terminal may cause fixed metal rotor or contact failure due to flux invasion into the movable part and/or the contact point. The soldering iron should not come in contact with the stator of the trimmer capacitor. If such contact does occur, the trimmer capacitor may be damaged.

(6) Our recommended chlorine content of solder is as follows.

- (a) Solder paste: 0.2wt% max.
- (b) String solder: 0.5wt% max.

(7) Do not use water-soluble flux (for water cleaning). To prevent the deterioration of trimmer capacitor characteristics, apply flux only to terminals.

(8) When soldering the TZC3 series, the solder should not flow into the staking part of the substrate. If such flow does occur, driver slot rotation will be damaged.

2. Mounting

(1) Do not apply excessive force (preferably 5.0 N [Ref: 500gf] max.), when the trimmer capacitor is mounted on the PCB.

(2) Do not warp and/or bend PCB to protect trimmer capacitor from breakage.

(3) Use a pick-up nozzle of a suitable dimension. (2.5mm external diameter and 1.5mm bore diameter.)

3. Cleaning

This product cannot be cleaned because of open construction.

4. Other

Note the polarity of the trimmer capacitor to minimize influence by stray capacitance.

(Refer to the dimensions concerning the polarity.)

Notice (Handling)

1. Use suitable screwdrivers that fit comfortably in driver slot.

Recommended screwdriver for manual adjustment
Standard type --> MURATA: KMDR080

2. When adjusting with a screwdriver, do not apply excessive force (preferably 1.0 N [Ref: 100gf] max.) to minimize capacitance drift. Excessive force applied to the screwdriver slot may cause deformation of the products.

3. Do not apply adhesive, lock paints, or any other substances to the trimmer capacitor to secure the rotor position. They may cause corrosion or electrical contact problems.

Notice (Other)

Before using trimmer capacitors, please test after assembly in your particular mass production system.

Ceramic Trimmer Capacitors

TZW4 Series

Features

1. To meet high power application due to withstanding voltage 550Vdc.
2. Extremely high self-resonant frequency.
(More than 3GHz at rated C max.)
3. Typical application: Impedance matching for Cellular Base Station.
4. High Q value in more than VHF, UHF and Microwave bands.
(More than 200 in 500MHz, C max.)
5. Available for pick and place machine. Possible thinner design due to 2.6mm low profile.
6. Non-electrical contact construction (rotor as middle electrode) provides high reliability.
7. Compact size: 4.2(W)x5.2(L)x2.6max.(H)mm.

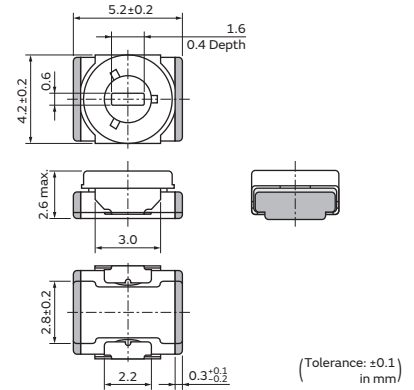

4

Applications

1. Transmitting power amplifier for Cellular base station
2. Transmitting amplifier for PHS base station
3. High frequency electric circuit
4. High power radio transmission
5. Transponder amplifier for cable TV

| Part Number | C min. (max.) (pF) | C max. (pF) | TC | Q | Rated Voltage | Withstanding Voltage |
|--------------|--------------------|--------------|---------------|--------------------------|---------------|----------------------|
| TZW4Z010A001 | 0.4 | 1.0 +50/-0% | NP0±150ppm/°C | 200min. at 500MHz, Cmax. | 250Vdc | 550Vdc |
| TZW4Z1R5A001 | 0.4 | 1.5 +100/-0% | NP0±150ppm/°C | 200min. at 500MHz, Cmax. | 250Vdc | 550Vdc |

Insulation Resistance: 10000M ohm Torque: 1.5 to 10.0mNm Operating Temperature Range: -55 to +125°C

Construction

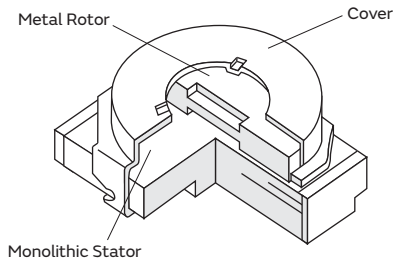

Temperature Characteristics

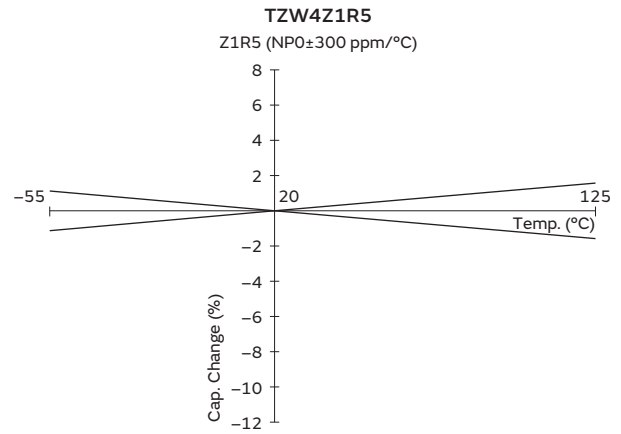
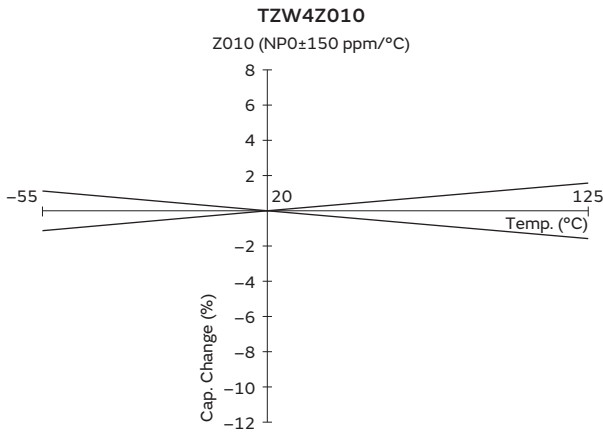

Frequency Characteristics

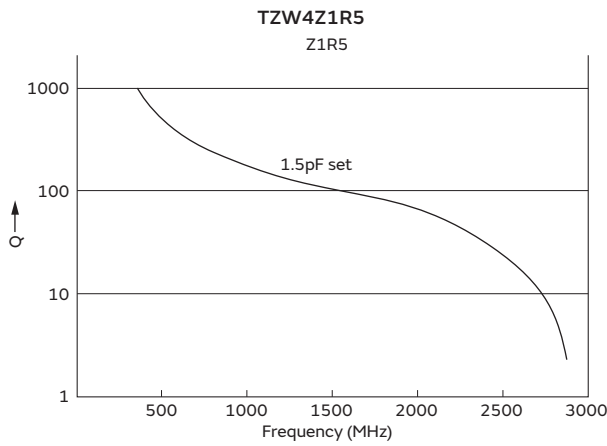

Land Pattern

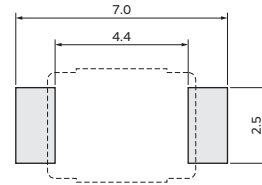

(Tolerance: ±0.1 in mm)

4

Temperature Profile

●Reflow Soldering Profile

①Soldering profile for Lead-free solder (96.5Sn/3Ag/0.5Cu)

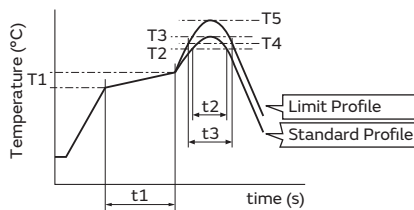

| Standard Profile | | | | | |
|------------------|---------------|------------|--------------|-----------------------|-----------------|
| Pre-heating | | Heating | | Peak temperature (T3) | Cycle of reflow |
| Temp. (T1) | Time (t1) | Temp. (T2) | Time (t2) | | |
| 150 to 180°C | 60 to 120sec. | 220°C | 30 to 60sec. | 245±3°C | 2 times |

| Limit Profile | | | | | |
|---------------|---------------|------------|--------------|-----------------------|-----------------|
| Pre-heating | | Heating | | Peak temperature (T5) | Cycle of reflow |
| Temp. (T1) | Time (t1) | Temp. (T4) | Time (t3) | | |
| 150 to 180°C | 60 to 120sec. | 230°C | 30 to 50sec. | 260 +5/-0°C | 2 times |

②Soldering profile for Eutectic solder (63Sn/37Pb)

(Limit profile: refer to ①)

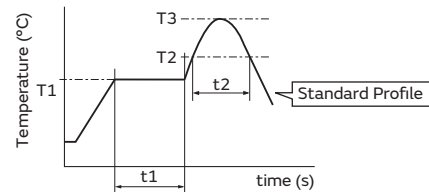

| Standard Profile | | | | | |
|------------------|---------------|------------|-----------|-----------------------|-----------------|
| Pre-heating | | Heating | | Peak temperature (T3) | Cycle of reflow |
| Temp. (T1) | Time (t1) | Temp. (T2) | Time (t2) | | |
| 150°C | 60 to 120sec. | 183°C | 30sec. | 230 +5/-0°C | 1 time |

●Soldering Iron

| Standard Profile | | | |
|-----------------------------------|----------------|-----------------------------|-------------------------|
| Temperature of soldering iron tip | Soldering time | Soldering iron power output | Cycle of soldering iron |
| 350±10°C | 3sec. max. | 30W max. | 1 time |

Notice (Storage and Operating Conditions)

1. Do not use the trimmer capacitor under atmosphere of RTV silicone rubber (Room Temperature Vulcanizing Silicone Rubber) except Acetone liberating silicone sealant.
2. Before using trimmer capacitors, please store under the conditions of -10 to +40°C and 30 to 85%RH.
3. Do not store in or near corrosive gasses.
4. Use within 6 months of delivery.
5. Do not store under direct sunlight.
6. Do not use the trimmer capacitor under the conditions listed below.
 - (1) Corrosive gasses atmosphere (Ex. Chlorine gas, Hydrogen sulfide gas, Ammonia gas, Sulfuric acid gas, Nitric oxide gas, etc.)
 - (2) In liquid (Ex. water, oil, medical liquid, organic solvent, etc.)
 - (3) Dusty/dirty atmosphere
 - (4) Direct sunlight
 - (5) Static voltage or electric/magnetic fields
 - (6) Direct sea breeze
 - (7) Other variations of the above

Notice (Soldering and Mounting)

1. Soldering
 - (1) TZW4 series can be soldered by reflow soldering method and soldering iron. Do not use flow soldering method (dipping).
 - (2) Soldering conditions
Refer to the temperature profile.
If the soldering conditions are not suitable, e.g., excessive time and/or excessive temperature, the trimmer capacitor may deviate from the specified characteristics.
 - (3) The amount of solder is critical.
 - (4) The thickness of solder paste should be printed from 150 micro m to 200 micro m and the dimension of land pattern should be Murata's standard land pattern used at reflow soldering.
Insufficient amounts of solder can lead to insufficient soldering strength on PCB.
Excessive amounts of solder may cause bridging between the terminals or contact failure due to flux wicking up.
 - (5) When using soldering iron, the diameter of the string solder shall be less than 0.5mm. The string solder shall be applied to the lower part of the terminal only. Do not apply flux except to the terminals. Excessive amounts of solder and/or applying solder to the upper part of the terminal may cause fixed metal rotor or the contact failure due to flux invasion into the movable part and/or the contact point. The soldering iron should not come in contact with the monolithic stator of the trimmer capacitor. If such contact does occur, the trimmer capacitor may be damaged.
 - (6) Our recommended chlorine content of solder is as follows.
 - (a) Solder paste: 0.2wt% max.
 - (b) String solder: 0.5wt% max.
 - (7) Do not use water-soluble flux (for water cleaning). To prevent the deterioration of trimmer capacitor characteristics, apply flux only to terminals.
2. Mounting
 - (1) Do not apply excessive force (preferably 5.0 N [Ref: 500gf] max.), when the trimmer capacitor is mounted on the PCB.
 - (2) Do not warp and/or bend PCB to protect trimmer capacitor from breaking.
 - (3) Use a pick-up nozzle of a suitable dimension. (4.0mm external diameter and 1.2mm bore diameter.)
3. Cleaning
This product cannot be cleaned because of open construction.

Notice (Handling)

1. Use suitable screwdrivers that fit comfortably in driver slot.
-Recommended screwdriver for manual adjustment
VESSEL : No.9000 -1.3x30
(Murata P/N is KMDR130)
2. When adjusting with a screwdriver, do not apply excessive force (preferably 1.0 N [Ref: 100gf] max.) to minimize capacitance drift. Excessive force applied to the screwdriver slot may cause deformation of the products.
3. Do not apply adhesive, lock paints, or any other substances to the trimmer capacitor to secure the rotor position. They may cause corrosion or electrical contact problems.

Notice (Other)

Before using trimmer capacitors, please test after assembly in your particular mass production system.

Ceramic Trimmer Capacitors

TZB4 Series

Features

1. Miniature rectangular shape:
4.0(W)x4.5(L)x3.0(H)mm.
2. Color coded case facilitates identification of capacitance range.
3. Designed for automatic placement in surface mount applications.
4. Designed to withstand flux baths and solder baths (with cover film type).
5. Can be temporarily attached to PCB with adhesives (Terminal style A and B).
6. Can be reflow and flow (with cover film type) soldering method.
7. Stable characteristics over a wide frequency range.
(Resonant frequency: 1000MHz min. / 6pF)

Applications

1. Car audio systems
2. Hybrid ICs
3. Remote keyless entry systems
4. Surveillance cameras
5. Burglarproof devices
6. Entry phone



A Type

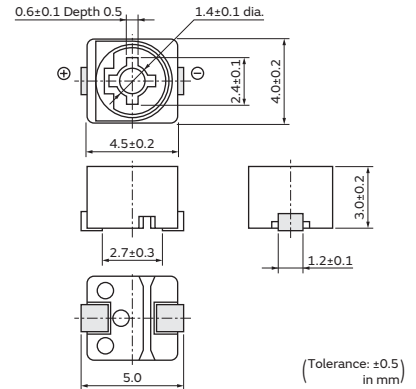

B Type

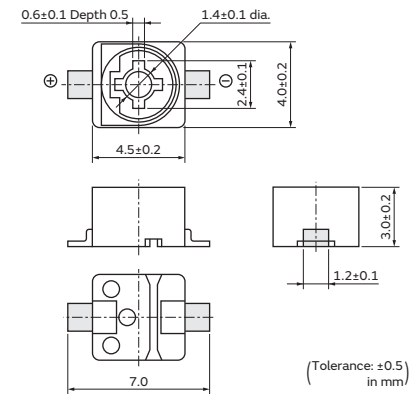

| Part Number | C min. (max.) (pF) | C max. (pF) | TC | Q | Rated Voltage | Withstanding Voltage | Stator/Case Color |
|--------------|--------------------|---------------|-----------------|------------------------|---------------|----------------------|-------------------|
| TZB4Z030□□10 | 1.4 | 3.0 +50/-0% | NP0±200ppm/°C | 300min. at 1MHz, Cmax | 100Vdc | 220Vdc | Brown |
| TZB4Z060□□10 | 2.0 | 6.0 +50/-0% | NP0±200ppm/°C | 500min. at 1MHz, Cmax. | 100Vdc | 220Vdc | Blue |
| TZB4Z100□□10 | 3.0 | 10.0 +50/-0% | NP0±300ppm/°C | 500min. at 1MHz, Cmax. | 100Vdc | 220Vdc | White |
| TZB4R200□□10 | 4.5 | 20.0 +50/-0% | N750±400ppm/°C | 500min. at 1MHz, Cmax | 100Vdc | 220Vdc | Red |
| TZB4P300□□10 | 6.5 | 30.0 +50/-0% | N1200±500ppm/°C | 300min. at 1MHz, Cmax | 100Vdc | 220Vdc | Green |
| TZB4P400□□10 | 8.5 | 40.0 +50/-0% | N1200±500ppm/°C | 300min. at 1MHz, Cmax | 100Vdc | 220Vdc | Yellow |
| TZB4Z250□□10 | 4.0 | 25.0 +100/-0% | NP0±300ppm/°C | 300min. at 1MHz, Cmax. | 50Vdc | 110Vdc | Black+Marking |
| TZB4R500□□10 | 7.0 | 50.0 +100/-0% | N750±300ppm/°C | 300min. at 1MHz, Cmax | 50Vdc | 110Vdc | Black+Marking |

Insulation Resistance: 10000M ohm Torque: 1.5 to 9.8mNm Operating Temperature Range: -25 to +85°C
 First blank: Terminal Type Second blank: Cover film codes (A: not provided, B: provided)
 rex. TZB4Z100AB10: Terminal Type is A, and Cover film is provided.

Construction

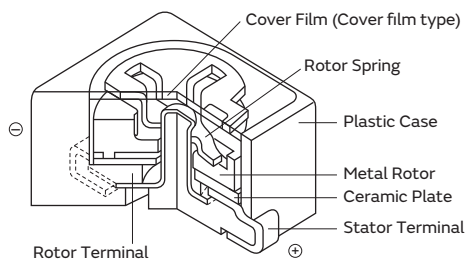

Land Pattern/Mounting Holes

A Type

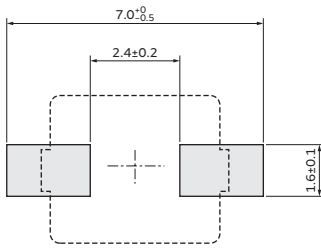

(in mm)

B Type

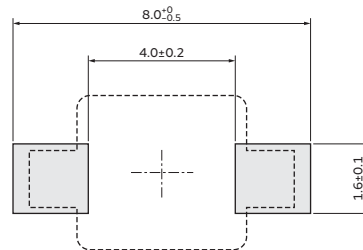

(in mm)

Temperature Characteristics

TZB4Z030

Z030 (NP0±200 ppm/°C)

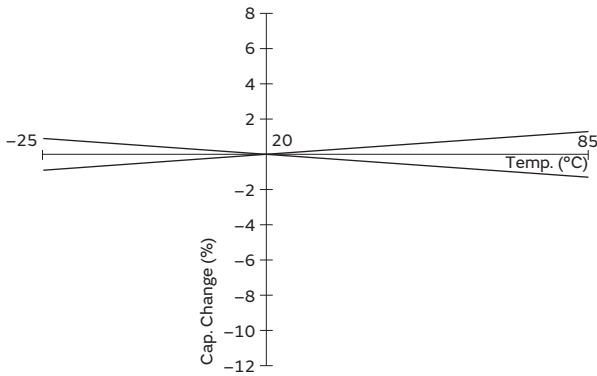

TZB4Z060

Z060 (NP0±200 ppm/°C)

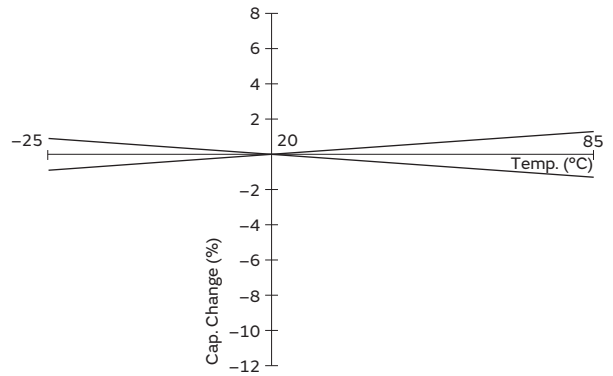

TZB4Z100

Z100 (NP0±300 ppm/°C)

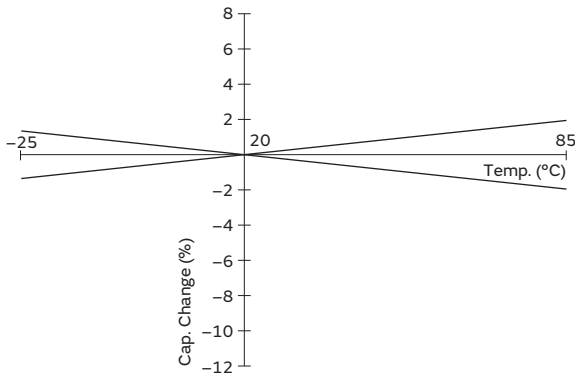

TZB4R200

R200 (N750±400 ppm/°C)

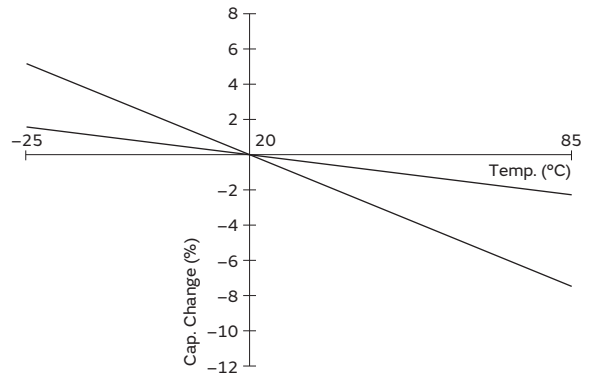

TZB4P300

P300 (N1200±500 ppm/°C)

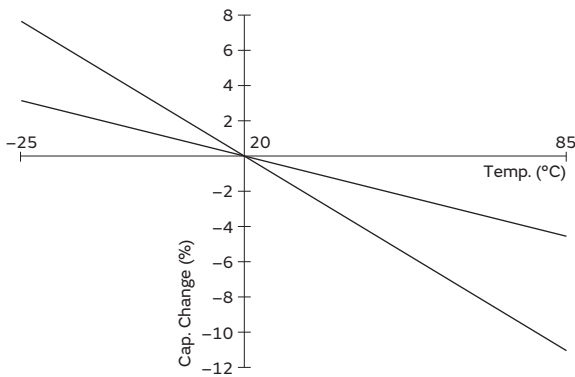

TZB4P400

P400 (N1200±500 ppm/°C)

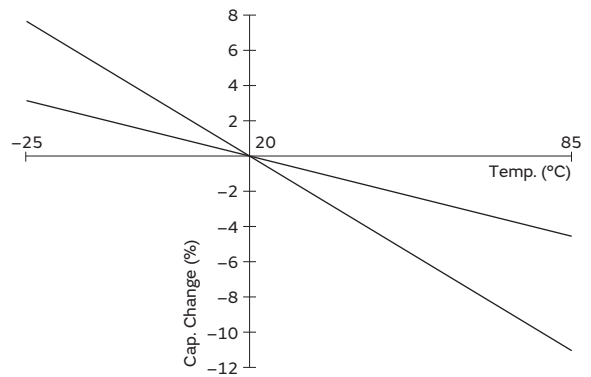

Continued on the following page. ↗

Continued from the preceding page. ↘

Temperature Characteristics

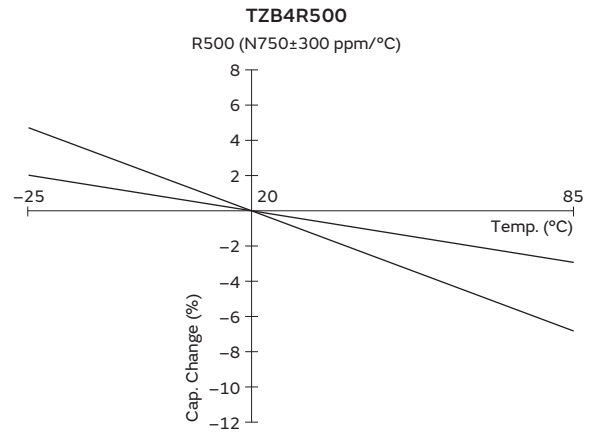
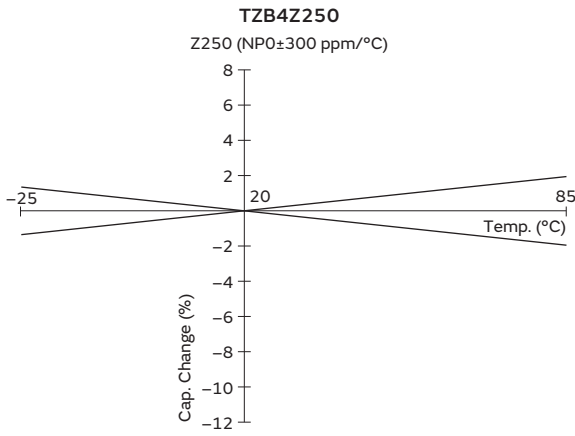

Frequency Characteristics

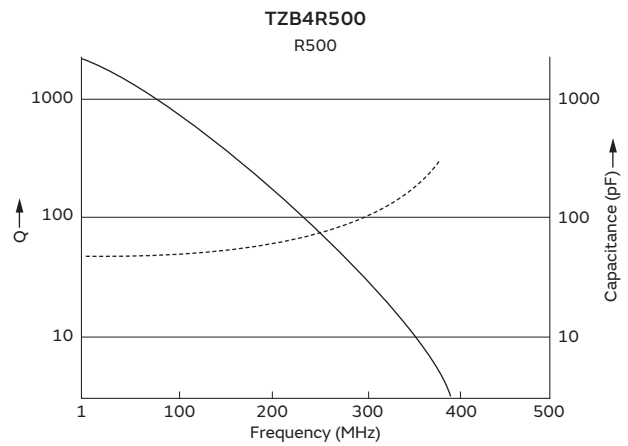
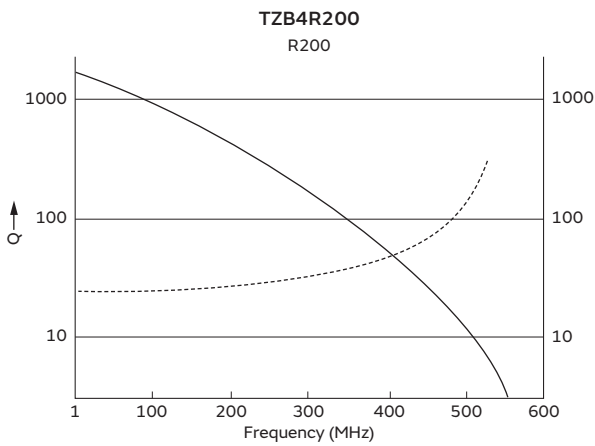
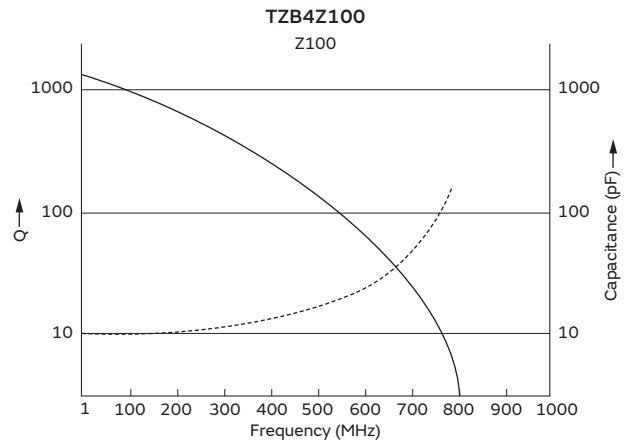
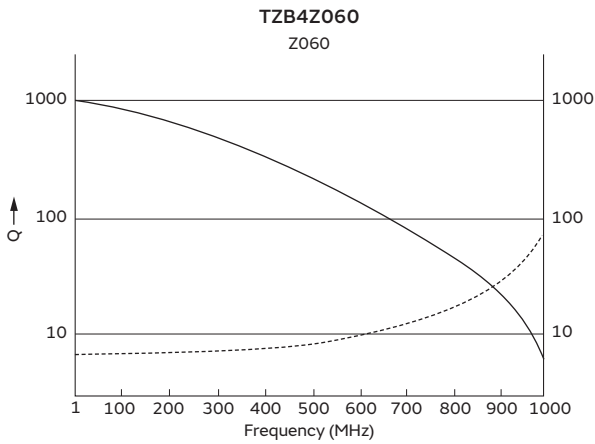

5

Temperature Profile

●Flow Soldering Profile

Soldering profile for Lead-free solder (96.5Sn/3Ag/0.5Cu), Eutectic solder (63Sn/37Pb)

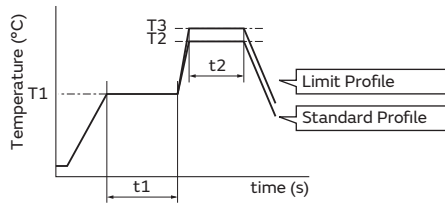

• Immerse the body in solder bath, available for cover film type.

| Standard Profile | | | | |
|------------------|---------------|------------|------------|-----------------|
| Pre-heating | | Heating | | Cycle of reflow |
| Temp. (T1) | Time (t1) | Temp. (T2) | Time (t2) | |
| 150°C | 60 to 120sec. | 250°C | 5sec. max. | 1 time |

| Limit Profile | | | | |
|---------------|---------------|------------|------------|-----------------|
| Pre-heating | | Heating | | Cycle of reflow |
| Temp. (T1) | Time (t1) | Temp. (T3) | Time (t2) | |
| 150°C | 60 to 120sec. | 265±3°C | 5sec. max. | 2 times |

●Reflow Soldering Profile

①Soldering profile for Lead-free solder (96.5Sn/3Ag/0.5Cu)

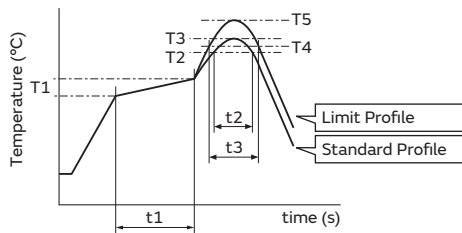

| Standard Profile | | | | | |
|------------------|---------------|------------|--------------|-----------------------|-----------------|
| Pre-heating | | Heating | | Peak temperature (T3) | Cycle of reflow |
| Temp. (T1) | Time (t1) | Temp. (T2) | Time (t2) | | |
| 150 to 180°C | 60 to 120sec. | 220°C | 30 to 60sec. | 245±3°C | 2 times |

| Limit Profile | | | | | |
|---------------|---------------|------------|--------------|-----------------------|-----------------|
| Pre-heating | | Heating | | Peak temperature (T5) | Cycle of reflow |
| Temp. (T1) | Time (t1) | Temp. (T4) | Time (t3) | | |
| 150 to 180°C | 60 to 120sec. | 230°C | 30 to 50sec. | 260 +5/-0°C | 2 times |

• Available for terminal shape A, B, and E.

②Soldering profile for Eutectic solder (63Sn/37Pb)

(Limit profile: refer to ①)

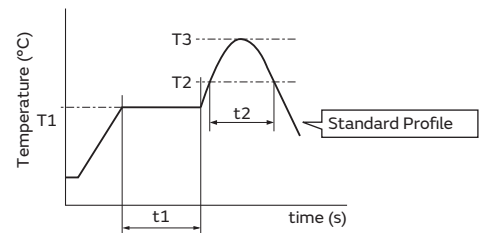

| Standard Profile | | | | | |
|------------------|---------------|------------|-----------|-----------------------|-----------------|
| Pre-heating | | Heating | | Peak temperature (T3) | Cycle of reflow |
| Temp. (T1) | Time (t1) | Temp. (T2) | Time (t2) | | |
| 150°C | 60 to 120sec. | 183°C | 30sec. | 230 +5/-0°C | 1 time |

5

●Soldering Iron

| Standard Profile | | | |
|-----------------------------------|----------------|-----------------------------|-------------------------|
| Temperature of soldering iron tip | Soldering time | Soldering iron power output | Cycle of soldering iron |
| 350±10°C | 3sec. max. | 30W max. | 1 time |

Notice (Storage and Operating Conditions)

- Do not use the trimmer capacitor under atmosphere of RTV silicone rubber (Room Temperature Vulcanizing Silicone Rubber) except Acetone liberating silicone sealant.
- Before using trimmer capacitors, please store under the conditions of -10 to +40°C and 30 to 85%RH.
- Do not store in or near corrosive gasses.
- Use within 6 months of delivery.
- Do not store under direct sunlight.
- Do not use the trimmer capacitor under the conditions listed below.
 - Corrosive gasses atmosphere (ex. Chlorine gas, Hydrogen sulfide gas, Ammonia gas, Sulfuric acid gas, Nitric oxide gas, etc.)
 - In liquid (ex. water, oil, medical liquid, organic solvent, etc.)
 - Dusty / dirty atmosphere
 - Direct sunlight
 - Static voltage or electric/magnetic fields
 - Direct sea breeze
 - Other variations of the above

Notice (Soldering and Mounting)

1. Soldering

- (1) Can be soldered by reflow soldering method, flow soldering method, and soldering iron.
- (2) Soldering conditions
Refer to the temperature profile.
If the soldering conditions are not suitable, e.g., excessive time and/or excessive temperature, the trimmer capacitor may deviate from the specified characteristics.
- (3) The amount of solder is critical.
- (4) The thickness of solder paste should be printed from 150 micro m to 200 micro m and the dimension of land pattern should be Murata's standard land pattern used at reflow soldering. Insufficient amounts of solder can lead to insufficient soldering strength on PCB. Excessive amounts of solder may cause bridging between the terminals or contact failure due to flux wicking up.
- (5) When using soldering iron, the string solder shall be applied to the lower part of the terminal only. Do not apply flux except to the terminals. Excessive amounts of solder and/or applying solder to the upper part of the terminal may cause fixed rotor or contact failure due to flux invasion into the movable part and/or the contact point. The soldering iron should not come in contact with the plastic case of the trimmer capacitor. If such contact does occur, the trimmer capacitor may be damaged.
- (6) Our recommended chlorine content of solder is as follows.
 - (a) Solder paste: 0.2wt% max.
 - (b) String solder: 0.5wt% max.
- (7) Do not use water-soluble flux (for water cleaning). To prevent the deterioration of trimmer capacitor characteristics, apply flux only to terminals.

2. Mounting

- (1) Do not apply excessive force (preferably 5.0N [Ref: 500gf] max.), when the trimmer capacitor is mounted on the PCB.
- (2) Do not warp and/or bend PCB to protect trimmer capacitor from breakage.
- (3) When bending the terminals, do not apply excessive force to the body of the product to protect the terminal fixing part from damage.
- (4) Use a pick-up nozzle of a suitable dimension.
 - > Without cover film type
 - External dimensions of 4.5x4.0mm and 2.5mm bore diameter.
 - > With cover film type
 - 4.0mm external diameter and 2.0mm bore diameter.

3. Cleaning [with cover film type]

Isopropyl alcohol and ethyl alcohol are available material for cleaning. If you use any other type of solvent, please evaluate performance in your application. Moreover, please confirm that no damage has occurred to the trimmer capacitor after cleaning in your conditions.

4. Other

Note the polarity of the trimmer capacitor to minimize influence by stray capacitance.
(Refer to the dimensions concerning the polarity.)

Notice (Handling)

1. Use suitable screwdrivers that fit comfortably in driver slot.

- (1) Recommended screwdriver for manual adjustment
MURATA: KMDR010
- (2) Recommended screwdriver bit for automatic adjustment
MURATA: KMBT010

2. When adjusting with a screwdriver, do not apply excessive force (preferably 1.0 N [Ref: 100gf] max.) to minimize capacitance drift. Excessive force applied to the screwdriver slot may cause deformation of the products.

3. Do not apply adhesive, lock paints, or any other substances to the trimmer capacitor to secure the rotor position. They may cause corrosion or electrical contact problems.
4. Do not break the cover film before the completion of PCB mounting, soldering, and cleaning.
5. Do not clean the trimmer capacitor after the cover film has been broken.
6. To break the cover film, first turn the screwdriver more than 360°, and set the capacitance value. (Inserting the screwdriver only will not break the cover film.)

Notice (Other)

Before using trimmer capacitors, please test after assembly in your particular mass production system.

Packaging

Minimum Quantity

| Part Number | Minimum Quantity (pcs.) | | |
|-------------|-------------------------|-------------|------|
| | ø180mm Reel | ø330mm Reel | Bulk |
| TZR1 | 3000 | - | 500 |
| TZY2 | 2000 | - | 500 |
| TZC3 | 1000 | - | 500 |
| TZW4 | 500 | - | 100 |
| TZB4 | 500 | 2500 | 500 |

Tape Dimensions

TZR1 Series

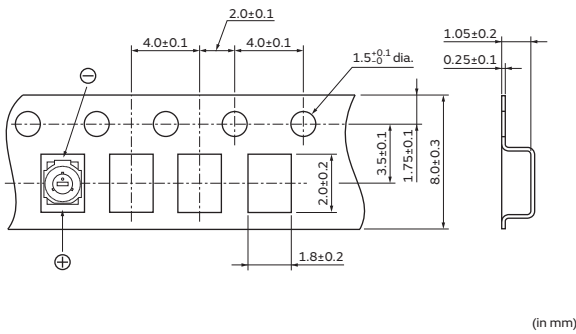

TZY2 Series

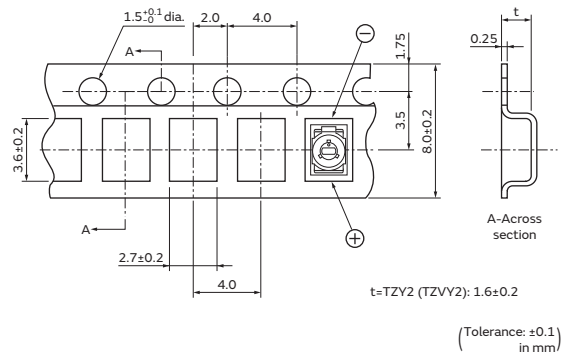

TZC3 Series

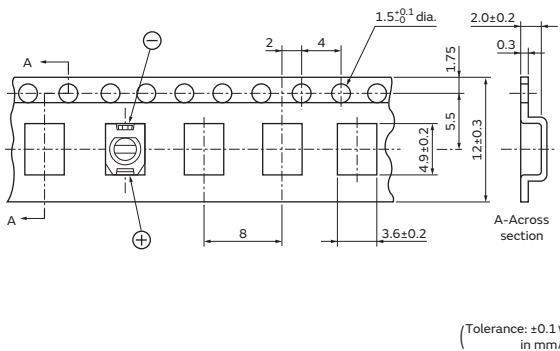

TZW4 Series

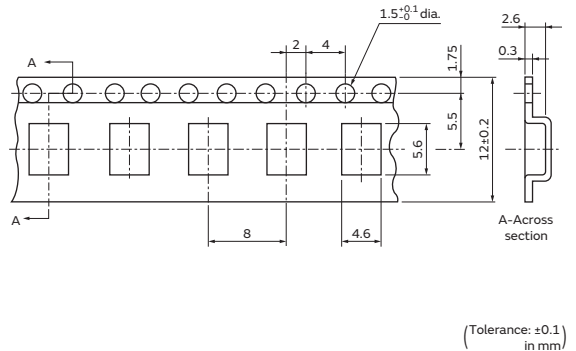

TZB4 Series

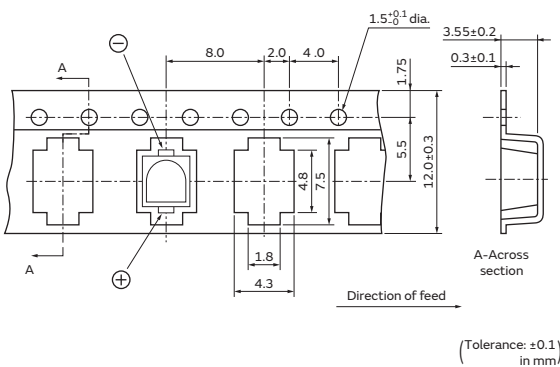

Continued on the following page. ↗

Packaging

Continued from the preceding page. ↘

Reel Dimensions (180mm diameter)

TZR1/TZY2 Series

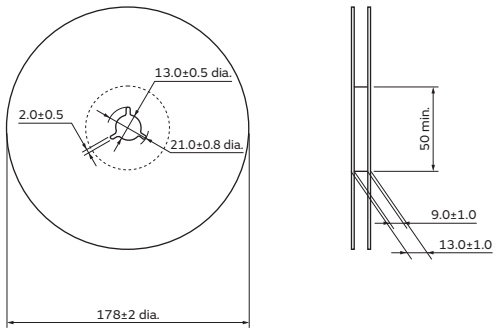

(in mm)

TZC3/TZW4/TZB4 Series

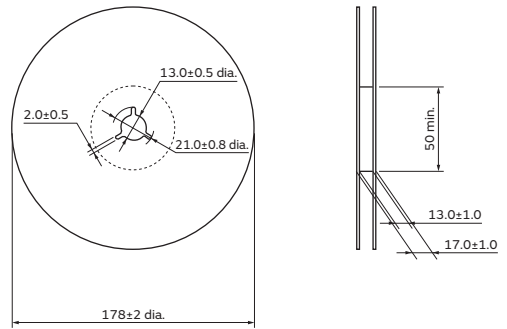

(in mm)

Reel Dimensions (330mm diameter)

TZB4 Series

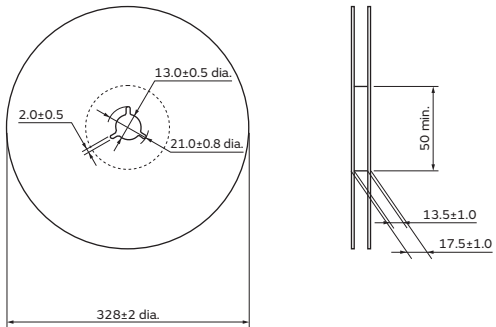

(in mm)

Recommended Adjustment Tools

Please use the following recommended screwdrivers.

You can order these drivers using the part numbers below.

Although you can also adjust the capacitance value using commercial products, please use one with the same head size as the driver listed below.

For Manual Adjustment

| Series | MURATA Model Number | Manufacturer's Model Number | Shape |
|--------|---------------------|--------------------------------|--|
| TZR1 | KMDR160 | MURATA MFG. KMDR160 | <p>Bit shape: ⊖Minus (0.3x0.13)</p> <p>(in mm)</p> |
| TZY2 | KMDR020 | VESSEL MFG. NO.9000 -0.9x30 | <p>Bit shape: ⊖Minus (0.9x30)</p> <p>(in mm)</p> |
| TZC3 | KMDR080 | VESSEL MFG. NO.9000 +1.7x30 | <p>Bit shape: ⊕Plus (1.7x30)</p> <p>(in mm)</p> |
| TZB4 | KMDR010 | MURATA MFG. KMDR010 | <p>Bit shape: ⊖Minus (2.2x0.4)</p> <p>(in mm)</p> |
| TZW4 | KMDR130 | VESSEL MFG. NO.9000 -1.3x30 | <p>Bit shape: ⊖Minus (1.3x30)</p> <p>(in mm)</p> |

For Automatic Adjustment

| Series | MURATA Model Number | Manufacturer's Model Number | Shape |
|--------|---------------------|-----------------------------|--|
| TZY2 | KMBT020 | MURATA MFG. KMBT020 | <p>Bit shape: ⊖Minus (0.6±0.05)</p> <p>(in mm)</p> |
| TZB4 | KMBT010 | MURATA MFG. KMBT010 | <p>Bit shape: ⊖Minus (2.2x0.4)</p> <p>(in mm)</p> |

Qualified Standards

The products listed herein have been produced
by a ISO9001 certified factory.

MURATA FACTORY

Sabae Murata Mfg. Co., Ltd.

* No ODCs (Ozone Depleting Chemicals) are used on
any Murata trimmer capacitors.

Global Locations

For details please visit www.murata.com



⚠ Note

1 Export Control

For customers outside Japan:

No Murata products should be used or sold, through any channels, for use in the design, development, production, utilization, maintenance or operation of, or otherwise contribution to (1) any weapons (Weapons of Mass Destruction [nuclear, chemical or biological weapons or missiles] or conventional weapons) or (2) goods or systems specially designed or intended for military end-use or utilization by military end-users.

For customers in Japan:

For products which are controlled items subject to the "Foreign Exchange and Foreign Trade Law" of Japan, the export license specified by the law is required for export.

2 Please contact our sales representatives or product engineers before using the products in this catalog for the applications listed below, which require especially high reliability for the prevention of defects which might directly damage a third party's life, body or property, or when one of our products is intended for use in applications other than those specified in this catalog.

- ① Aircraft equipment
- ② Aerospace equipment
- ③ Undersea equipment
- ④ Power plant equipment
- ⑤ Medical equipment
- ⑥ Transportation equipment (vehicles, trains, ships, etc.)
- ⑦ Traffic signal equipment
- ⑧ Disaster prevention / crime prevention equipment
- ⑨ Data-processing equipment
- ⑩ Application of similar complexity and/or reliability requirements to the applications listed above

3 Product specifications in this catalog are as of September 2017. They are subject to change or our products in it may be discontinued without advance notice. Please check with our sales representatives or product engineers before ordering. If there are any questions, please contact our sales representatives or product engineers.

4 Please read rating and ⚠CAUTION (for storage, operating, rating, soldering, mounting and handling) in this catalog to prevent smoking and/or burning, etc.

5 This catalog has only typical specifications. Therefore, please approve our product specifications or transact the approval sheet for product specifications before ordering.

6 Please note that unless otherwise specified, we shall assume no responsibility whatsoever for any conflict or dispute that may occur in connection with the effect of our and/or a third party's intellectual property rights and other related rights in consideration of your use of our products and/or information described or contained in our catalogs. In this connection, no representation shall be made to the effect that any third parties are authorized to use the rights mentioned above under licenses without our consent.

7 No ozone depleting substances (ODS) under the Montreal Protocol are used in our manufacturing process.

Murata Manufacturing Co., Ltd.

www.murata.com

muRata
INNOVATOR IN ELECTRONICS

Looking for pricing, stock, or lifecycle information?

Click below to explore more details on WIN SOURCE:

- ⊖ [View TZVY2Z060A110T00 on WIN SOURCE](#)
- ⊖ [Murata Electronics North America Information](#)

Optimize Your Supply Chain with WIN SOURCE Solutions

- ✓ Global Sourcing Solution
- ✓ Obsolete Management
- ✓ Cost Control Management
- ✓ Shortage Management
- ✓ Alternative Solution
- ✓ Excess Inventory Management