



**THE DATASHEET OF  
UC2843AQD8RQ1**



# UC2843A-Q1 Current-Mode PWM Controller

## 1 Features

- Qualified for automotive applications
- Extended temperature performance of  $-40^{\circ}\text{C}$  to  $125^{\circ}\text{C}$
- Optimized for off-line and DC-to-DC converters
- Low start-up current ( $<0.5\text{ mA}$ )
- Trimmed oscillator-discharge current
- Automatic feed-forward compensation
- Pulse-by-pulse current limiting
- Enhanced load-response characteristics
- Under-voltage lockout with hysteresis
- Double-pulse suppression
- High-current totem-pole output
- Internally trimmed bandgap reference
- 500-kHz operation
- Low  $R_{\text{O}}$  Error Amp
- Create a Custom Design Using the UC2843A-Q1 With the [WEBENCH® Power Designer](#)

## 2 Applications

- Switch mode power supplies (SMPS)
- DC-DC converters
- Power modules
- Industrial PSU
- Battery operated PSU

## 3 Description

The UC2843A-Q1 control device is a pin-for-pin compatible improved version of the UC2843. Providing the necessary features to control current mode switched mode power supplies, this device has the following improved features. Start up current is specified to be less than 0.5 mA. Oscillator discharge is trimmed to 8.3 mA. During undervoltage lockout, the output stage can sink at least 10 mA at less than 1.2 V for  $V_{\text{CC}}$  over 5 V.

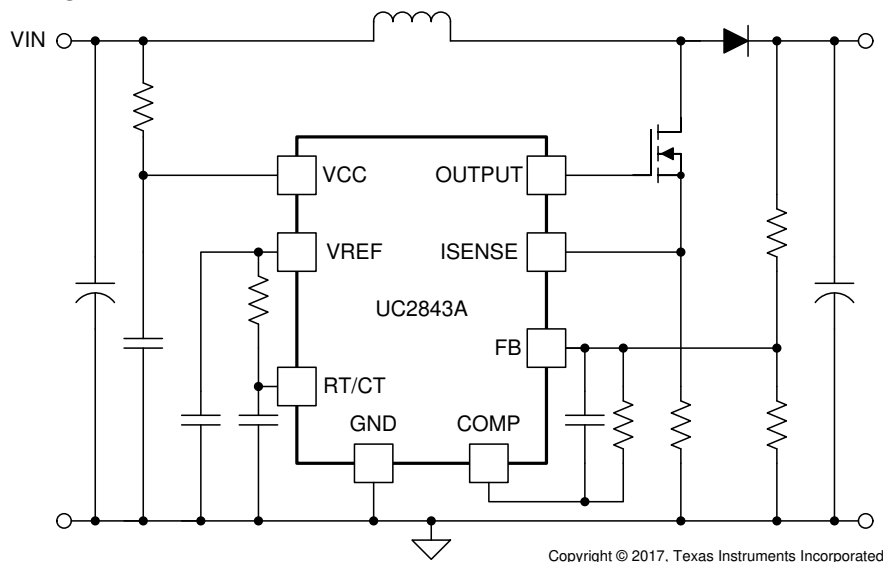
### Device Information<sup>(1)</sup>

PART NUMBER	PACKAGE	BODY SIZE (NOM)
UC2843A-Q1	SOIC (8)	5.80 mm × 4.81 mm

(1) For all available packages, see the orderable addendum at the end of the data sheet.

### Device Comparison Table

DEVICE	UVLO ON	UVLO OFF	MAX DUTY CYCLE
UC2843A-Q1	8.5 V	7.9 V	<100%



Simplified Application Diagram



## Table of Contents

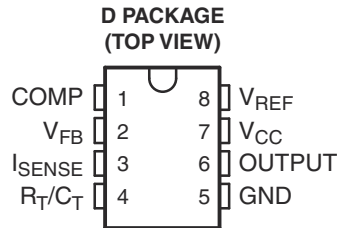
<b>1 Features</b> .....	1	<b>8 Application and Implementation</b> .....	13
<b>2 Applications</b> .....	1	8.1 Application Information.....	13
<b>3 Description</b> .....	1	8.2 Typical Application.....	13
<b>4 Revision History</b> .....	2	<b>9 Power Supply Recommendations</b> .....	14
<b>5 Pin Configuration and Functions</b> .....	3	<b>10 Layout</b> .....	15
Pin Functions.....	3	10.1 Layout Guidelines.....	15
<b>6 Specifications</b> .....	4	<b>11 Device and Documentation Support</b> .....	16
6.1 Absolute Maximum Ratings.....	4	11.1 Device Support.....	16
6.2 ESD Ratings.....	4	11.2 Documentation Support.....	16
6.3 Recommended Operating Conditions.....	4	11.3 Related Links.....	16
6.4 Electrical Characteristics.....	5	11.4 Receiving Notification of Documentation Updates..	17
6.5 Thermal Information.....	8	11.5 Support Resources.....	17
6.6 Typical Characteristics.....	8	11.6 Trademarks.....	17
<b>7 Detailed Description</b> .....	9	11.7 Electrostatic Discharge Caution.....	17
7.1 Overview.....	9	11.8 Glossary.....	17
7.2 Functional Block Diagram.....	9	<b>12 Mechanical, Packaging, and Orderable</b>	
7.3 Feature Description.....	9	<b>Information</b> .....	17
7.4 Device Functional Modes.....	12		

## 4 Revision History

NOTE: Page numbers for previous revisions may differ from page numbers in the current version.

<b>Changes from Revision * (May 2008) to Revision A (July 2022)</b>	<b>Page</b>
• Updated analog input pins 3 and 5 to 2, 3, and 4.....	4
• Added Junction Temperature, $T_J$ to the Absolute Maximum Ratings table.....	4
• Added Recommended Operating Conditions.....	4
• Changed Low-level Output Voltage from 15 V to 1.5 V.....	5

## 5 Pin Configuration and Functions



**Figure 5-1. SOIC Package 8-Pin D Top View**

## Pin Functions

**Table 5-1. Pin Functions**

SOIC (8)		I/O	DESCRIPTION
NAME	NO.		
COMP	1	O	Outputs the low impedance 1-MHz internal error amplifier that is also the input to the peak current limit or PWM comparator, with an open-loop gain (AVOL) of 90 dB. This pin is capable of sinking a maximum of 6 mA and is not internally current limited.
FB	2	I	Input to the error amplifier that can be used to control the power converter voltage-feedback loop for stability.
ISENSE	3	I	Input to the peak current limit, PWM comparator of the UCx84xA controllers. When used in conjunction with a current sense resistor, the error amplifier output voltage controls the power systems cycle-by-cycle peak current limit. The maximum peak current sense signal is internally clamped to 1 V. See Functional Block Diagram
RT/CT	4	I	Input to the internal oscillator that is programmed with an external timing resistor (RT) and timing capacitor (CT). See Oscillator for information on properly selecting these timing components. TI recommends using capacitance values from 470 pF to 4.7 nF. TI also recommends that the timing resistor values chosen be from 5 kΩ to 100 kΩ.
GND	5	-	This is the controller signal ground.
OUTPUT	6	O	Output of 1-A totem pole gate driver. This pin can sink and source up to 1 A of gate driver current. A gate driver resistor must be used to limit the gate driver current.
VCC	7	I	Bias input to the gate driver. This pin must have a biasing capacitor that is at least 10 times greater than the gate capacitance of the main switching FET used in the design.
VREF	8	O	Reference voltage output of the PWM controller. This pin must supply no more than 10 mA under normal operation. This output is short-circuit protected at roughly 100 mA. This reference is also used for internal comparators and needs a high frequency bypass capacitor of 1 μF. The VCC capacitor also must be at least 10 times greater than the capacitor on the VREF pin.

## 6 Specifications

### 6.1 Absolute Maximum Ratings

over operating free-air temperature range (unless otherwise noted)<sup>(1)</sup>

PARAMETER		MIN	MAX	UNIT
V <sub>CC</sub> voltage (low impedance source)	VCC pin		30	V
V <sub>CC</sub> voltage (I <sub>CC</sub> mA)			Self limiting	
Output current, I <sub>OUT</sub>			±1	A
Output energy (capacitive load)			5	μJ
Analog inputs (pins 2, 3, and 4)		-0.3	6.3	V
Maximum negative voltage	All pins	-0.3		V
Error amplifier output sink current, I <sub>COMP</sub>			10	mA
Power dissipation at T <sub>A</sub> ≤ 25°C			1	W
Lead temperature (soldering, 10 s)			260	°C
Junction temperature, T <sub>J</sub>		-55	150	°C
Storage temperature, T <sub>stg</sub>		-65	150	°C

- (1) Stresses beyond those listed under *Absolute Maximum Ratings* may cause permanent damage to the device. These are stress ratings only, which do not imply functional operation of the device at these or any other conditions beyond those indicated under [Section 6.3](#). Exposure to absolute-maximum-rated conditions for extended periods may affect device reliability.

### 6.2 ESD Ratings

		VALUE	UNIT
V <sub>(ESD)</sub>	Electrostatic discharge	Human-body model (HBM), per ANSI/ESDA/JEDEC JS-001 <sup>(1)</sup>	±2000
		Charged-device model (CDM), per JEDEC specification JESD22-C101 <sup>(2)</sup>	±1500

- (1) JEDEC document JEP155 states that 500-V HBM allows safe manufacturing with a standard ESD control process.  
(2) JEDEC document JEP157 states that 250-V CDM allows safe manufacturing with a standard ESD control process.

### 6.3 Recommended Operating Conditions

over operating free-air temperature range (unless otherwise noted)

		MIN	NOM	MAX	UNIT
V <sub>CC</sub>	Bias supply voltage		11		V
V <sub>FB</sub> , V <sub>RC</sub> , V <sub>VFB</sub>	Voltage on analog pins	-0.1		5	V
V <sub>OUT</sub>	Gate driver output voltage	-0.1		V <sub>CC</sub>	V
I <sub>VCC</sub>	Supply bias current			25	mA
I <sub>VREF</sub>	Output current			10	mA
f <sub>OSC</sub>	Oscillator frequency			500	kHz
T <sub>A</sub>	Operating free-air temperature	-40		85	°C

## 6.4 Electrical Characteristics

Unless otherwise stated, these specifications apply for  $T_A = -40^{\circ}\text{C}$  to  $125^{\circ}\text{C}$  (UC2843A-Q1);  $T_A = T_J$ ;  $V_{CC} = 15\text{ V}^{(1)}$ ;  $R_T = 10\text{ k}\Omega$ ;  $C_T = 3.3\text{ nF}$ .

PARAMETER	TEST CONDITIONS	MIN	TYP	MAX	UNIT
REFERENCE					
Output voltage	$T_J = 25^{\circ}\text{C}$ , $I_O = 1\text{ mA}$	4.95	5	5.05	V
Line regulation	$12 \leq V_{IN} \leq 25\text{ V}$		6	20	mV
Load regulation	$1 \leq I_O \leq 20\text{ mA}$		6	25	mV
Temperature stability <sup>(2)</sup>			0.2	0.4	mV/ $^{\circ}\text{C}$
Total output variation	Line, Load, Temperature	4.9		5.1	V
Output noise voltage <sup>(7)</sup>	$10\text{ Hz} \leq f \leq 10\text{ kHz}$ ; $T_J = 25^{\circ}\text{C}$		50		$\mu\text{V}$
Long-term stability <sup>(7)</sup>	$T_A = 125^{\circ}\text{C}$ , 1000 hrs		5	25	mV
Output short circuit		-30	-100	-180	mA
OSCILLATOR					
Initial accuracy	$T_J = 25^{\circ}\text{C}$	47	52	57	kHz
Voltage stability	$12 \leq V_{CC} \leq 25\text{ V}$		0.2	1	%
Temperature stability <sup>(7)</sup>	$T_{MIN} \leq T_A \leq T_{MAX}$		5		%
Amplitude <sup>(7)</sup>	$V_{RT/CT}$ (pin 4) peak to peak		1.7		V
Discharge current <sup>(4)</sup>	$T_J = 25^{\circ}\text{C}$ , $V_{RT/CT} = 2\text{ V}$	7.8	8.3	8.8	mA
	$V_{RT/CT} = 2\text{ V}$	7.5		8.8	

**UC2843A-Q1**

SGLS384A – MAY 2008 – REVISED NOVEMBER 2022

Unless otherwise stated, these specifications apply for  $T_A = -40^{\circ}\text{C}$  to  $125^{\circ}\text{C}$  (UC2843A-Q1);  $T_A = T_J$ ;  $V_{CC} = 15\text{ V}^{(1)}$ ;  $R_T = 10\text{ k}\Omega$ ;  $C_T = 3.3\text{ nF}$ .

PARAMETER		TEST CONDITIONS	MIN	TYP	MAX	UNIT
<b>ERROR AMPLIFIER</b>						
	Input voltage	$V_{COMP} = 2.5\text{ V}$	2.45	2.5	2.55	V
	Input bias current			-0.3	-1	$\mu\text{A}$
$A_{VOL}$	Open-loop gain	$2 \leq V_O \leq 4\text{ V}$	65	90		dB
	Unity gain bandwidth <sup>(7)</sup>	$T_J = 25^{\circ}\text{C}$	0.7	1		MHz
CMRR	Common mode rejection ratio	$12 \leq V_{CC} \leq 25\text{ V}$	60	70		dB
	Output sink current	$V_{FB} = 2.7\text{ V}$ , $V_{COMP} = 1.1\text{ V}$	2	6		mA
	Output source current	$V_{FB} = 2.3\text{ V}$ , $V_{COMP} = 5\text{ V}$	-0.5	-0.8		mA
	$V_{OUT}$ high	$V_{FB} = 2.3\text{ V}$ , $R_L = 15\text{ k}\Omega$ to ground	5	6		V
	$V_{OUT}$ low	$V_{FB} = 2.7\text{ V}$ , $R_L = 15\text{ k}\Omega$ to $V_{REF}$		0.7	1.1	V
<b>CURRENT SENSE</b>						
	Gain <sup>(5)</sup> <sup>(6)</sup>		2.85	3	3.15	V/V
	Maximum input signal <sup>(5)</sup>	$V_{COMP} = 5\text{ V}$	0.9	1	1.1	V
PSRR	Power supply rejection ratio <sup>(5)</sup>	$12 \leq V_{CC} \leq 25\text{ V}$		70		dB
	Input bias current			-2	-10	$\mu\text{A}$
	Delay to output <sup>(7)</sup>	$V_{ISENSE} = 0$ to $2\text{ V}$		150	300	ns
<b>OUTPUT</b>						
	Output low level	$I_{SINK} = 20\text{ mA}$		0.1	0.4	V
		$I_{SINK} = 200\text{ mA}$		1.5	2.2	
	Output high level	$I_{SOURCE} = 20\text{ mA}$	13	13.5		V
		$I_{SOURCE} = 200\text{ mA}$	12	13.5		
	Rise time <sup>(7)</sup>	$T_J = 25^{\circ}\text{C}$ , $C_L = 1\text{ nF}$		50	150	ns
	Fall time <sup>(7)</sup>	$T_J = 25^{\circ}\text{C}$ , $C_L = 1\text{ nF}$		50	150	ns
	UVLO saturation	$V_{CC} = 5\text{ V}$ , $I_{SINK} = 10\text{ mA}$		0.7	1.2	V
<b>UNDERVOLTAGE LOCKOUT</b>						
	Start threshold		7.8	8.4	9	V
	Minimum operation voltage after turnon		7	7.6	8.2	V
<b>PWM</b>						
	Maximum duty cycle		94	96	100	%
	Minimum duty cycle				0	%
<b>TOTAL STANDBY CURRENT</b>						
	Start-up current			0.3	0.5	mA
	Operating supply current	$V_{FB} = V_{ISENSE} = 0\text{ V}$		11	17	mA
	$V_{CC}$ Zener voltage	$I_{CC} = 25\text{ mA}$	30	34		V

- Adjust  $V_{CC}$  above the start threshold before setting at  $15\text{ V}$ .
- Temperature stability, sometimes referred to as average temperature coefficient, is described by the equation:  
 Temperature Stability =  $(V_{REF}(\text{max}) - V_{REF}(\text{min})) / (T_J(\text{max}) - T_J(\text{min}))$ .  $V_{REF}(\text{max})$  and  $V_{REF}(\text{min})$  are the maximum and minimum reference voltage measured over the appropriate temperature range. Note that the extremes in voltage do not necessarily occur at the extremes in temperature.
- Output frequency equals oscillator frequency.
- This parameter is measured with  $R_T = 10\text{ k}\Omega$  to  $V_{REF}$ . This contributes approximately  $300\text{ }\mu\text{A}$  of current to the measurement. The total current flowing into the  $R_T/R_C$  pin is approximately  $300\text{ }\mu\text{A}$  higher than the measured value.
- Parameter measured at trip point of latch with  $V_{FB}$  at  $0\text{ V}$ .

6. Gain is defined by:  $A = \Delta V_{\text{COMP}} / \Delta V_{\text{SENSE}}$ ;  $0 \leq V_{\text{SENSE}} \leq 0.8 \text{ V}$ .
7. Ensured by design, but not 100% production tested.

## 6.5 Thermal Information

THERMAL METRIC			UNIT
$\theta_{JA}$	Package Thermal impedance	97	°C/W

## 6.6 Typical Characteristics

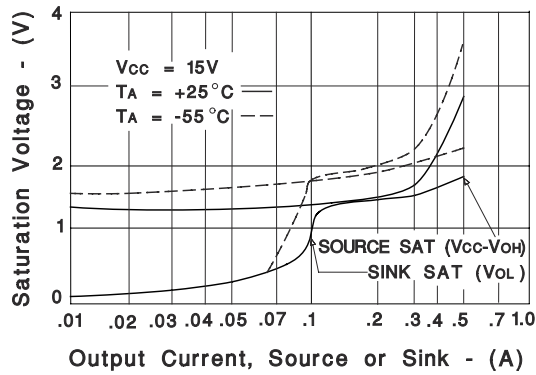


Figure 6-1. Output Saturation Characteristics

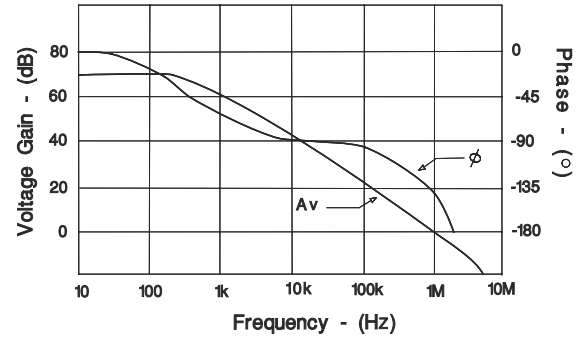


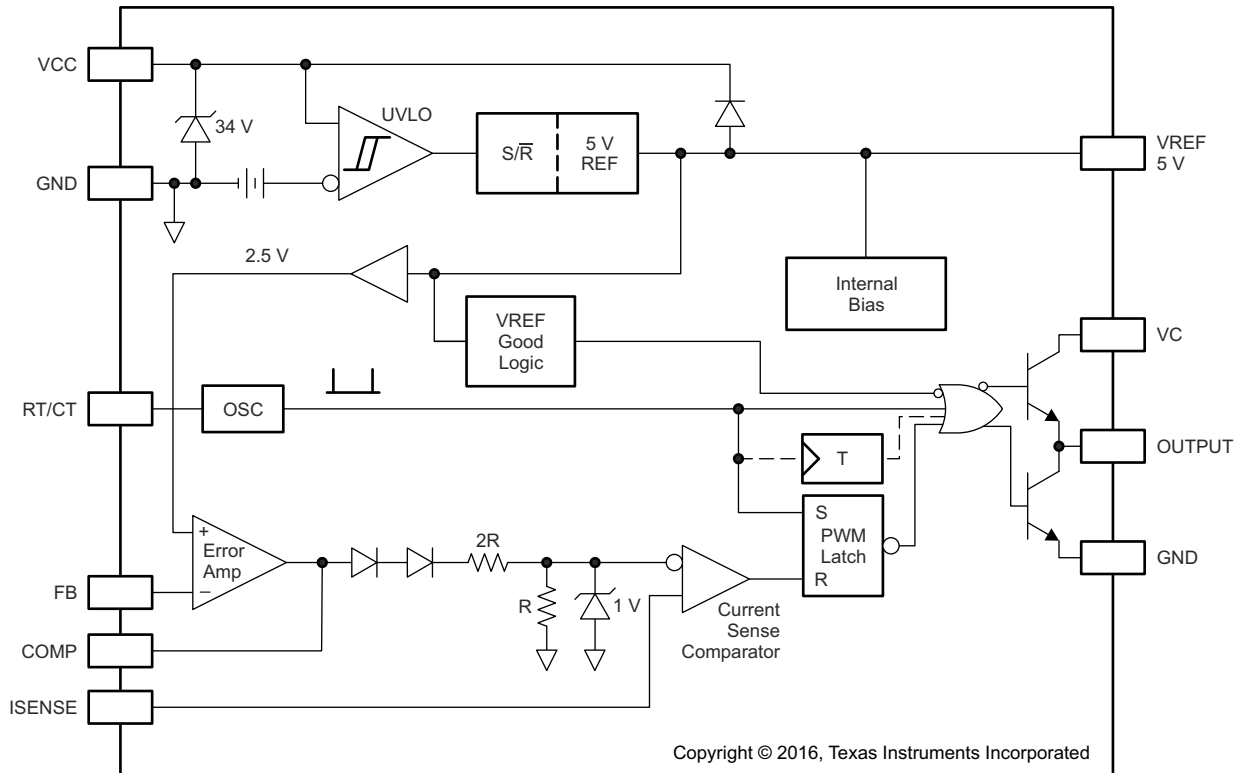
Figure 6-2. Error Amplifier Open-Loop Frequency Response

## 7 Detailed Description

### 7.1 Overview

The UC2843A-Q1 fixed-frequency pulse-width-modulator (PWM) controllers are designed to operate at switching frequencies up to 500 kHz. This controller is designed for peak current mode (PCM) and can be used in isolated and non-isolated power supply designs. These controllers can drive FETs directly from the output, which is capable of sourcing and sinking up to 1 A of gate driver current. These devices also have a built-in low-impedance amplifier that can be used in non-isolated designs to control the power supply output voltage and feedback loop.

### 7.2 Functional Block Diagram



### 7.3 Feature Description

#### 7.3.1 Pulse-by-Pulse Current Limiting

Pulse-by-pulse limiting is inherent in the current mode control scheme. An upper limit on the peak current can be established by simply clamping the error voltage. Accurate current limiting allows optimization of magnetic and power semiconductor elements while ensuring reliable supply operation.

#### 7.3.2 Current Sense Circuit

Peak current ( $I_S$ ) is determined by [Equation 1](#):

$$I_{S(\max)} \times \frac{1V}{R_S} \tag{1}$$

A small RC filter may be required to suppress switch transients.

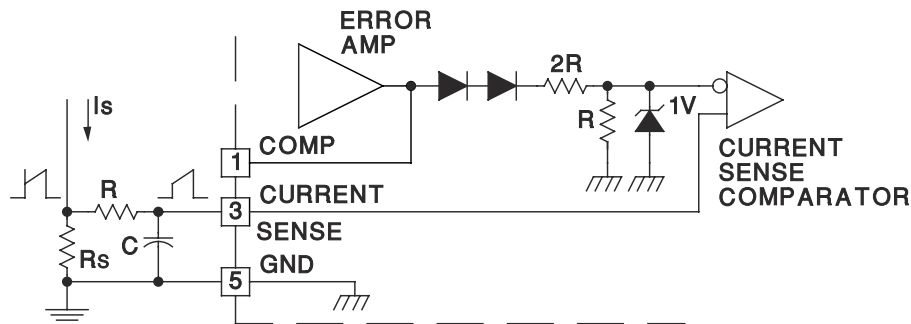


Figure 7-1. Current Sense Circuit Diagram

### 7.3.3 Error Amplifier Configuration

The error amplifier can source up to 0.8 mA, and sink up to 6 mA.

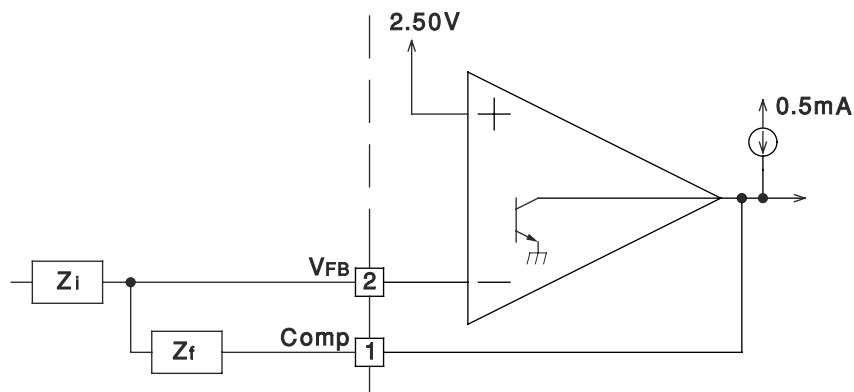
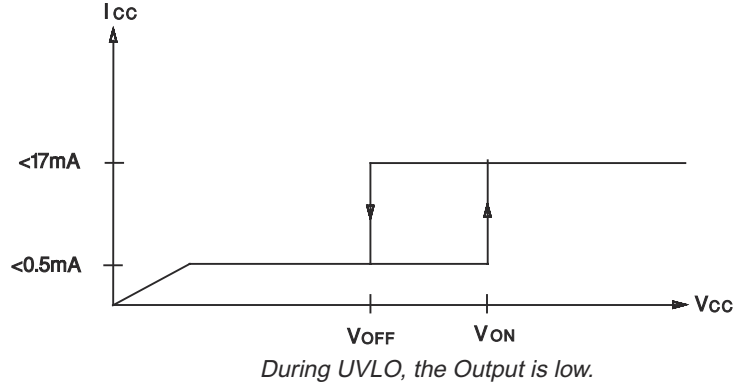
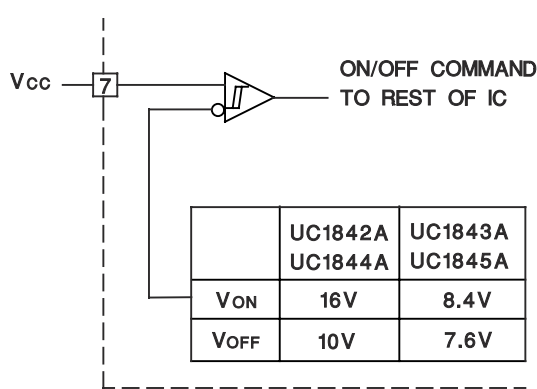


Figure 7-2. Error Amplifier Configuration Diagram

### 7.3.4 Undervoltage Lockout

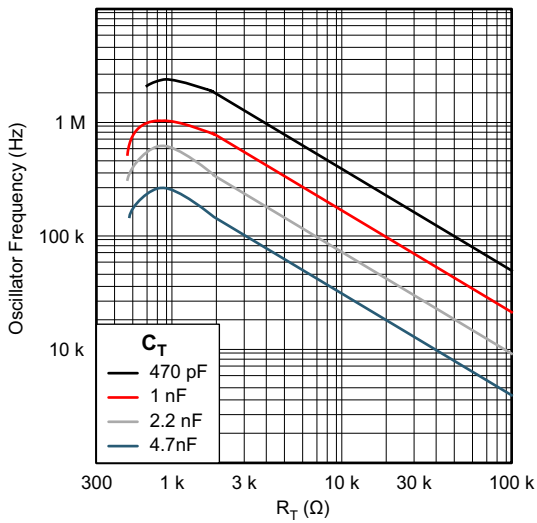
The UC2843A-Q1 device features undervoltage lockout protection circuits for controlled operation during power-up and power-down sequences. Undervoltage lockout thresholds for the UC2843A-Q1 device is optimized for two groups of applications: off-line power supplies and DC-DC converters. The UC2843A-Q1 controller has a much narrower  $V_{CC_{ON}}$  to  $V_{CC_{OFF}}$  hysteresis and may be used in DC to DC applications where the input is considered regulated.

During UVLO the device draws typically 0.3 mA of supply current. The low  $V_{CC}$  current of the UC2843A-Q1 results in lower power drawn from the line. The reduced start-up current is of particular concern in off-line supplies where the device is *powered-up* from the high-voltage DC rail, then bootstrapped to an auxiliary winding on the main transformer. Power is then dissipated in the start-up resistor which is sized by the device's start-up current. Lowering this by 50% in the UC2843A-Q1 reduces the resistors power loss by the same percentage. Once crossing the turnon threshold the device supply current increases typically to about 11 mA, During undervoltage lockout, the UC2843A-Q1 device prevent the power MOSFET from parasitically turning on due to the *Miller* effect at power-up. This improved design to the lower totem-pole transistor's operation during undervoltage lockout allows the devices to sink higher currents, up to 10 mA, at saturation voltages as low as 0.7 V, compared to the UCx84x devices which would only sink up to 0.2 mA under the same conditions.

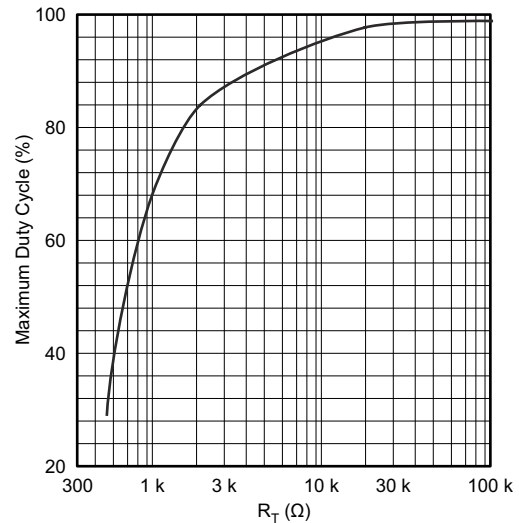


**Figure 7-3. Undervoltage Lockout**

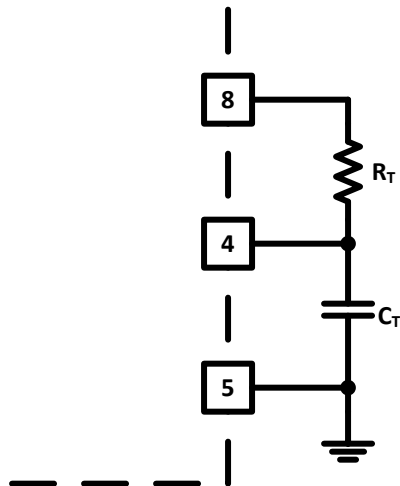
**7.3.5 Oscillator**



**Figure 7-4. Oscillator Frequency vs Timing Resistance**



**Figure 7-5. Maximum Duty Cycle vs Timing Resistance**



$$\text{For } R_T > 5 \text{ k} \quad f \approx \frac{1.72}{R_T \times C_T}$$

Figure 7-6. Oscillator Section

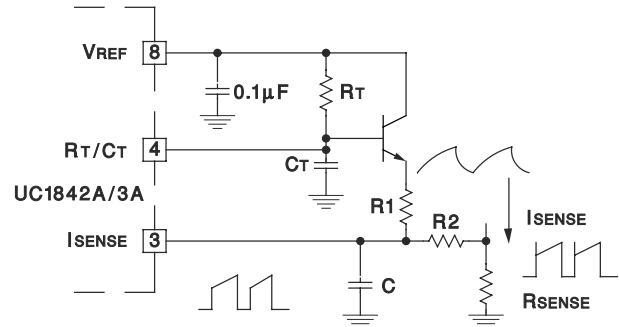


Figure 7-7. Slope Compensation

Precision operation at high frequencies with an accurate maximum duty cycle, see [Figure 7-5](#), can now be obtained with the UC2843A-Q1 device due to its trimmed oscillator discharge current. This nullifies the effects of production variations in the initial discharge current or dead time.

A fraction of the oscillator ramp can be resistively summed with the current sense signal, to provide slope compensation for converters requiring duty cycles over 50%. Capacitor C forms a filter with R2 to suppress the leading-edge switch spikes.

## 7.4 Device Functional Modes

### 7.4.1 Normal Operation

The device can be used in peak current mode (PCM) control or voltage mode (VM) control. When the converter is operating in PCM, the voltage amplifier output will regulate the converter's peak current and duty cycle. When the device is used in VM control, the voltage amplifier output will regulate the power converter's duty cycle. The regulation of the system's peak current and duty cycle can be achieved with the use of the integrated error amplifier and external feedback circuitry.

### 7.4.2 Undervoltage Lockout (UVLO) Start-Up

During system start-up, VCC voltage starts to rise from 0. Before the VCC voltage reaches its corresponding start threshold, the device is operating in UVLO mode. After the UVLO turn start-up threshold is met the device will become active and the reference will come up to 5 V.

### 7.4.3 UVLO Turnoff Mode

If the bias voltage to VCC drops below the UVLO minimum operating voltage, PWM switching stops and the reference will become inactive, returning to 0 V. The device can be restarted by applying a voltage greater than the UVLO start threshold to the VCC pin.

## 8 Application and Implementation

---

### Note

Information in the following applications sections is not part of the TI component specification, and TI does not warrant its accuracy or completeness. TI's customers are responsible for determining suitability of components for their purposes, as well as validating and testing their design implementation to confirm system functionality.

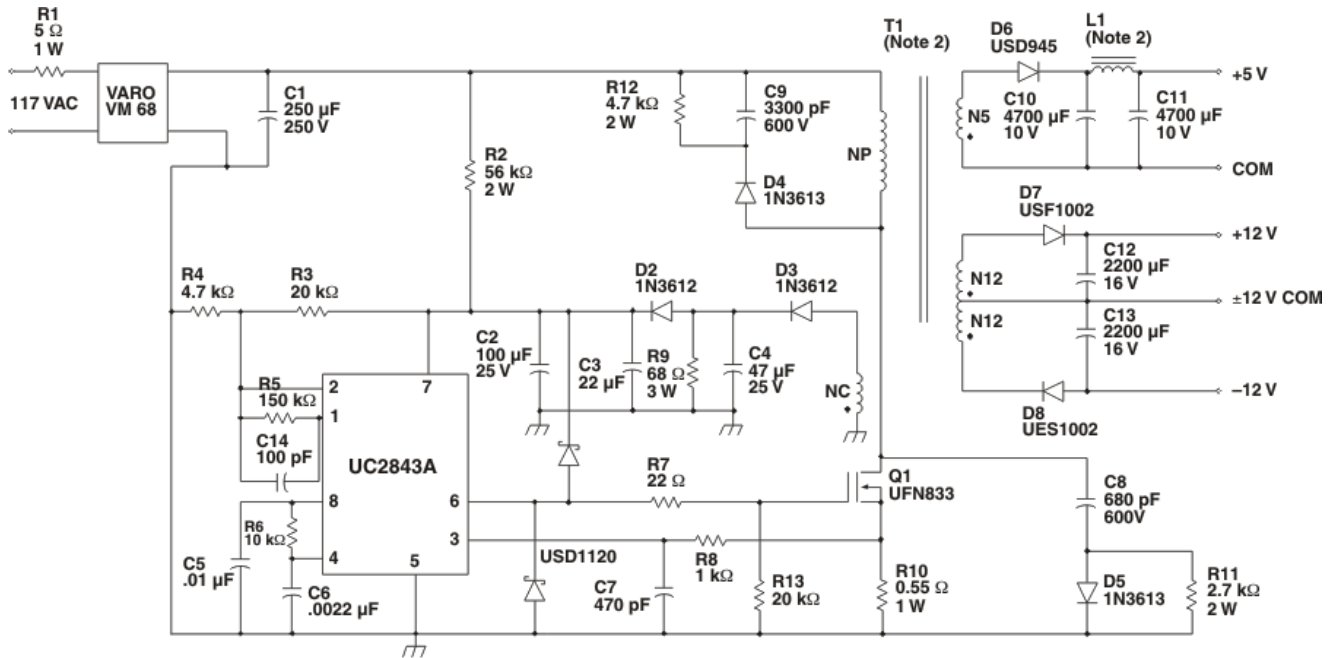
---

### 8.1 Application Information

The UC2843A-Q1 controller is a peak-current mode pulse-width modulator. The controller has an onboard amplifier and can be used in isolated or nonisolated power supply designs. There is an onboard totem-pole gate driver capable of delivering 1 A of peak current. This is a high-speed PWM capable of operating at switching frequencies up to 500 kHz.

### 8.2 Typical Application

A typical application for the UC2843A-Q1 in an off-line flyback converter is shown in [Figure 8-1](#). The UC2843A uses an inner current control loop that contains a small current sense resistor which senses the primary inductor current ramp. This current sense resistor transforms the inductor current waveform to a voltage signal that is input directly into the primary side PWM comparator. This inner loop determines the response to input voltage changes. An outer voltage control loop involves comparing a portion of the output voltage to a reference voltage at the input of an error amplifier. When used in an off-line isolated application, the voltage feedback of the isolated output is accomplished using a secondary-side error amplifier and adjustable voltage reference, such as the TL431. The error signal crosses the primary to secondary isolation boundary using an opto-isolator whose collector is connected to the VREF pin and the emitter is connected to FB. The outer voltage control loop determines the response to load changes.



**Power Supply Specifications**

1. Input Voltage 95 VAC to 130 VAC (50 Hz/60 Hz)
2. Line Isolation 3750 V
3. Switching Frequency 40 kHz
4. Efficiency, Full Load 70%
5. Output Voltage:
  - A. 5 V ±5%; 1-A to 4-A Load
  - B. 12 V ±3%; 0.1-A to 0.3-A Load; Ripple voltage: 100 mV P-P Max
  - C. -12 V ±3%; 0.1-A to 0.3-A Load; Ripple voltage: 100 mV P-P Max

**Figure 8-1. Typical Flyback Application Circuit**

**9 Power Supply Recommendations**

TI recommends using the UCx84xA in isolated or non-isolated peak current mode control power supplies. The device can be used in buck, boost, flyback, and forwarded converter-based power supply topologies.

## 10 Layout

### 10.1 Layout Guidelines

- Star grounding techniques must be used.
- Current loops must be kept as short and narrow as possible.
- The IC ground and power ground must meet at the return for the input bulk capacitor. Ensure that high frequency and high current from the power stage does not go through the signal ground paths.
- A high-frequency bypass capacitor ( $C_3$ ) must be placed across VCC and GND pins as close as possible to the pins.
- Resistor  $R_8$  and capacitor  $C_7$  form a low-pass filter for the current sense signal.  $C_7$  must be as close to CS and GND pins as possible.
- Capacitor  $C_5$  must be as close to VREF and GND pins as possible.

## 11 Device and Documentation Support

### 11.1 Device Support

#### 11.1.1 Development Support

- TI Engineer-to-Engineer Support Forum, <https://e2e.ti.com/>

##### 11.1.1.1 Custom Design With WEBENCH® Tools

[Click here](#) to create a custom design using the UCx84xA device with the WEBENCH® Power Designer.

1. Start by entering the input voltage ( $V_{IN}$ ), output voltage ( $V_{OUT}$ ), and output current ( $I_{OUT}$ ) requirements.
2. Optimize the design for key parameters such as efficiency, footprint, and cost using the optimizer dial.
3. Compare the generated design with other possible solutions from Texas Instruments.

The WEBENCH Power Designer provides a customized schematic along with a list of materials with real-time pricing and component availability.

In most cases, these actions are available:

- Run electrical simulations to see important waveforms and circuit performance
- Run thermal simulations to understand board thermal performance
- Export customized schematic and layout into popular CAD formats
- Print PDF reports for the design, and share the design with colleagues

Get more information about WEBENCH tools at [www.ti.com/WEBENCH](http://www.ti.com/WEBENCH).

#### 11.1.2 Device Nomenclature

$C_{IN}$	Input bulk capacitance
$C_{OUT}$	Output capacitance
$D$	Duty cycle
$ESR$	Equivalent series resistance
$G_{BC}(f)$	An estimate of the transfer function from the output of the opto-isolator to the PWM control voltage.
$G_O$	The DC gain of the control to output transfer function.
$G_{OPTO}(f)$	The approximate transfer function across the opto-isolator in the design.
$I_{LPM}$	Transformer primary average current
$I_{LpPK}$	Peak transformer primary current
$L_{PM}$	Transformer primary magnetizing inductance
$L_{SM}$	Transformer secondary magnetizing inductance
$N_{PS}$	Primary to secondary transformer turns ratio
$N_{AS}$	Auxiliary to secondary transformer turns ratio
$T_V(f)$	is the feedback control loop transfer function.
$V_{INripple}$	Input ripple voltage

### 11.2 Documentation Support

#### 11.2.1 Related Documentation

For related documentation see the following:

[Design Review: 150 Watt Current-Mode Flyback](#) (SLUP078)

#### 11.3 Related Links

The table below lists quick access links. Categories include technical documents, support and community resources, tools and software, and quick access to sample or buy.

**Table 11-1. Related Links**

PARTS	PRODUCT FOLDER	SAMPLE & BUY	TECHNICAL DOCUMENTS	TOOLS & SOFTWARE	SUPPORT & COMMUNITY
UC1842A	<a href="#">Click here</a>	<a href="#">Click here</a>	<a href="#">Click here</a>	<a href="#">Click here</a>	<a href="#">Click here</a>
UC1843A	<a href="#">Click here</a>	<a href="#">Click here</a>	<a href="#">Click here</a>	<a href="#">Click here</a>	<a href="#">Click here</a>
UC1844A	<a href="#">Click here</a>	<a href="#">Click here</a>	<a href="#">Click here</a>	<a href="#">Click here</a>	<a href="#">Click here</a>
UC1845A	<a href="#">Click here</a>	<a href="#">Click here</a>	<a href="#">Click here</a>	<a href="#">Click here</a>	<a href="#">Click here</a>
UC2842A	<a href="#">Click here</a>	<a href="#">Click here</a>	<a href="#">Click here</a>	<a href="#">Click here</a>	<a href="#">Click here</a>
UC2843A	<a href="#">Click here</a>	<a href="#">Click here</a>	<a href="#">Click here</a>	<a href="#">Click here</a>	<a href="#">Click here</a>
UC2844A	<a href="#">Click here</a>	<a href="#">Click here</a>	<a href="#">Click here</a>	<a href="#">Click here</a>	<a href="#">Click here</a>
UC2845A	<a href="#">Click here</a>	<a href="#">Click here</a>	<a href="#">Click here</a>	<a href="#">Click here</a>	<a href="#">Click here</a>
UC3842A	<a href="#">Click here</a>	<a href="#">Click here</a>	<a href="#">Click here</a>	<a href="#">Click here</a>	<a href="#">Click here</a>
UC3843A	<a href="#">Click here</a>	<a href="#">Click here</a>	<a href="#">Click here</a>	<a href="#">Click here</a>	<a href="#">Click here</a>
UC3844A	<a href="#">Click here</a>	<a href="#">Click here</a>	<a href="#">Click here</a>	<a href="#">Click here</a>	<a href="#">Click here</a>
UC3845A	<a href="#">Click here</a>	<a href="#">Click here</a>	<a href="#">Click here</a>	<a href="#">Click here</a>	<a href="#">Click here</a>

### 11.4 Receiving Notification of Documentation Updates

To receive notification of documentation updates, navigate to the device product folder on [ti.com](#). Click on *Subscribe to updates* to register and receive a weekly digest of any product information that has changed. For change details, review the revision history included in any revised document.

### 11.5 Support Resources

[TI E2E™ support forums](#) are an engineer's go-to source for fast, verified answers and design help — straight from the experts. Search existing answers or ask your own question to get the quick design help you need.

Linked content is provided "AS IS" by the respective contributors. They do not constitute TI specifications and do not necessarily reflect TI's views; see TI's [Terms of Use](#).

### 11.6 Trademarks

TI E2E™ is a trademark of Texas Instruments.  
WEBENCH® is a registered trademark of Texas Instruments.  
All trademarks are the property of their respective owners.

### 11.7 Electrostatic Discharge Caution



This integrated circuit can be damaged by ESD. Texas Instruments recommends that all integrated circuits be handled with appropriate precautions. Failure to observe proper handling and installation procedures can cause damage.

ESD damage can range from subtle performance degradation to complete device failure. Precision integrated circuits may be more susceptible to damage because very small parametric changes could cause the device not to meet its published specifications.


### 11.8 Glossary

[TI Glossary](#) This glossary lists and explains terms, acronyms, and definitions.

## 12 Mechanical, Packaging, and Orderable Information

The following pages include mechanical, packaging, and orderable information. This information is the most current data available for the designated devices. This data is subject to change without notice and revision of this document. For browser-based versions of this data sheet, refer to the left-hand navigation.

**PACKAGING INFORMATION**

Orderable Device	Status (1)	Package Type	Package Drawing	Pins	Package Qty	Eco Plan (2)	Lead finish/ Ball material (6)	MSL Peak Temp (3)	Op Temp (°C)	Device Marking (4/5)	Samples
UC2843AQD8RQ1	ACTIVE	SOIC	D	8	2500	RoHS & Green	NIPDAU	Level-1-260C-UNLIM	-40 to 125	(2843AQ, UC2843AQ)	

(1) The marketing status values are defined as follows:

**ACTIVE:** Product device recommended for new designs.

**LIFEBUY:** TI has announced that the device will be discontinued, and a lifetime-buy period is in effect.

**NRND:** Not recommended for new designs. Device is in production to support existing customers, but TI does not recommend using this part in a new design.

**PREVIEW:** Device has been announced but is not in production. Samples may or may not be available.

**OBsolete:** TI has discontinued the production of the device.

(2) **RoHS:** TI defines "RoHS" to mean semiconductor products that are compliant with the current EU RoHS requirements for all 10 RoHS substances, including the requirement that RoHS substance do not exceed 0.1% by weight in homogeneous materials. Where designed to be soldered at high temperatures, "RoHS" products are suitable for use in specified lead-free processes. TI may reference these types of products as "Pb-Free".

**RoHS Exempt:** TI defines "RoHS Exempt" to mean products that contain lead but are compliant with EU RoHS pursuant to a specific EU RoHS exemption.

**Green:** TI defines "Green" to mean the content of Chlorine (Cl) and Bromine (Br) based flame retardants meet JS709B low halogen requirements of <=100ppm threshold. Antimony trioxide based flame retardants must also meet the <=1000ppm threshold requirement.

(3) MSL, Peak Temp. - The Moisture Sensitivity Level rating according to the JEDEC industry standard classifications, and peak solder temperature.

(4) There may be additional marking, which relates to the logo, the lot trace code information, or the environmental category on the device.

(5) Multiple Device Markings will be inside parentheses. Only one Device Marking contained in parentheses and separated by a "~" will appear on a device. If a line is indented then it is a continuation of the previous line and the two combined represent the entire Device Marking for that device.

(6) Lead finish/Ball material - Orderable Devices may have multiple material finish options. Finish options are separated by a vertical ruled line. Lead finish/Ball material values may wrap to two lines if the finish value exceeds the maximum column width.

**Important Information and Disclaimer:**The information provided on this page represents TI's knowledge and belief as of the date that it is provided. TI bases its knowledge and belief on information provided by third parties, and makes no representation or warranty as to the accuracy of such information. Efforts are underway to better integrate information from third parties. TI has taken and continues to take reasonable steps to provide representative and accurate information but may not have conducted destructive testing or chemical analysis on incoming materials and chemicals. TI and TI suppliers consider certain information to be proprietary, and thus CAS numbers and other limited information may not be available for release.

In no event shall TI's liability arising out of such information exceed the total purchase price of the TI part(s) at issue in this document sold by TI to Customer on an annual basis.

**OTHER QUALIFIED VERSIONS OF UC2843A-Q1 :**

- Catalog : [UC2843A](#)

NOTE: Qualified Version Definitions:

- Catalog - TI's standard catalog product

**TAPE AND REEL INFORMATION**

**QUADRANT ASSIGNMENTS FOR PIN 1 ORIENTATION IN TAPE**


\*All dimensions are nominal

Device	Package Type	Package Drawing	Pins	SPQ	Reel Diameter (mm)	Reel Width W1 (mm)	A0 (mm)	B0 (mm)	K0 (mm)	P1 (mm)	W (mm)	Pin1 Quadrant
UC2843AQD8RQ1	SOIC	D	8	2500	330.0	12.4	6.4	5.2	2.1	8.0	12.0	Q1

**TAPE AND REEL BOX DIMENSIONS**


\*All dimensions are nominal

Device	Package Type	Package Drawing	Pins	SPQ	Length (mm)	Width (mm)	Height (mm)
UC2843AQD8RQ1	SOIC	D	8	2500	356.0	356.0	35.0



D0008A

# PACKAGE OUTLINE

SOIC - 1.75 mm max height

SMALL OUTLINE INTEGRATED CIRCUIT



4214825/C 02/2019

NOTES:

1. Linear dimensions are in inches [millimeters]. Dimensions in parenthesis are for reference only. Controlling dimensions are in inches. Dimensioning and tolerancing per ASME Y14.5M.
2. This drawing is subject to change without notice.
3. This dimension does not include mold flash, protrusions, or gate burrs. Mold flash, protrusions, or gate burrs shall not exceed  $.006$  [0.15] per side.
4. This dimension does not include interlead flash.
5. Reference JEDEC registration MS-012, variation AA.

# EXAMPLE BOARD LAYOUT

D0008A

SOIC - 1.75 mm max height

SMALL OUTLINE INTEGRATED CIRCUIT



LAND PATTERN EXAMPLE  
 EXPOSED METAL SHOWN  
 SCALE:8X



SOLDER MASK DETAILS

4214825/C 02/2019

NOTES: (continued)

- 6. Publication IPC-7351 may have alternate designs.
- 7. Solder mask tolerances between and around signal pads can vary based on board fabrication site.

# EXAMPLE STENCIL DESIGN

D0008A

SOIC - 1.75 mm max height

SMALL OUTLINE INTEGRATED CIRCUIT



SOLDER PASTE EXAMPLE  
BASED ON .005 INCH [0.125 MM] THICK STENCIL  
SCALE:8X

4214825/C 02/2019

NOTES: (continued)

8. Laser cutting apertures with trapezoidal walls and rounded corners may offer better paste release. IPC-7525 may have alternate design recommendations.
9. Board assembly site may have different recommendations for stencil design.

## IMPORTANT NOTICE AND DISCLAIMER

TI PROVIDES TECHNICAL AND RELIABILITY DATA (INCLUDING DATA SHEETS), DESIGN RESOURCES (INCLUDING REFERENCE DESIGNS), APPLICATION OR OTHER DESIGN ADVICE, WEB TOOLS, SAFETY INFORMATION, AND OTHER RESOURCES "AS IS" AND WITH ALL FAULTS, AND DISCLAIMS ALL WARRANTIES, EXPRESS AND IMPLIED, INCLUDING WITHOUT LIMITATION ANY IMPLIED WARRANTIES OF MERCHANTABILITY, FITNESS FOR A PARTICULAR PURPOSE OR NON-INFRINGEMENT OF THIRD PARTY INTELLECTUAL PROPERTY RIGHTS.

These resources are intended for skilled developers designing with TI products. You are solely responsible for (1) selecting the appropriate TI products for your application, (2) designing, validating and testing your application, and (3) ensuring your application meets applicable standards, and any other safety, security, regulatory or other requirements.

These resources are subject to change without notice. TI grants you permission to use these resources only for development of an application that uses the TI products described in the resource. Other reproduction and display of these resources is prohibited. No license is granted to any other TI intellectual property right or to any third party intellectual property right. TI disclaims responsibility for, and you will fully indemnify TI and its representatives against, any claims, damages, costs, losses, and liabilities arising out of your use of these resources.

TI's products are provided subject to [TI's Terms of Sale](#) or other applicable terms available either on [ti.com](http://ti.com) or provided in conjunction with such TI products. TI's provision of these resources does not expand or otherwise alter TI's applicable warranties or warranty disclaimers for TI products.

TI objects to and rejects any additional or different terms you may have proposed.

Mailing Address: Texas Instruments, Post Office Box 655303, Dallas, Texas 75265  
Copyright © 2022, Texas Instruments Incorporated

## Looking for pricing, stock, or lifecycle information?

Click below to explore more details on WIN SOURCE:

 [View UC2843AQD8RQ1](#) on WIN SOURCE

 [Texas Instruments](#) Information

## Optimize Your Supply Chain with WIN SOURCE Solutions

-  Global Sourcing Solution
-  Obsolete Management
-  Cost Control Management
-  Shortage Management
-  Alternative Solution
-  Excess Inventory Management