



**THE DATASHEET OF
UC3176QP**



Full Bridge Power Amplifier

FEATURES

- Dual Power Operational Amplifiers
- $\pm 2A$ Output Current Guaranteed
- Precision Current Sense Amplifier
- Two Supply Monitoring Inputs
- Parking Function and Under-Voltage Lockout
- Safe Operating Area Protection
- 3V to 35V Operation

DESCRIPTION

The UC3176/7 family of full bridge power amplifiers is rated for a continuous output current of 2A. Intended for use in demanding servo applications such as disk head positioning, the onboard current sense amplifier can be used to obtain precision control of load current, or where voltage mode drive is required, a standard voltage feedback scheme can be used. Output stage protection includes foldback current limiting and thermal shutdown, resulting in a very rugged device.

Auxiliary functions on this device include a dual input under-voltage comparator that can be programmed to respond to low voltage conditions on two independent supplies. In response to an under-voltage condition the power Op-Amps are inhibited and a high current, 100mA, open collector drive output is activated. A separate Park/Inhibit command input.

The devices are operational over a 3V to 35V supply range. Internal under-voltage lockout provides predictable power-up and power-down characteristics.

BLOCK DIAGRAM

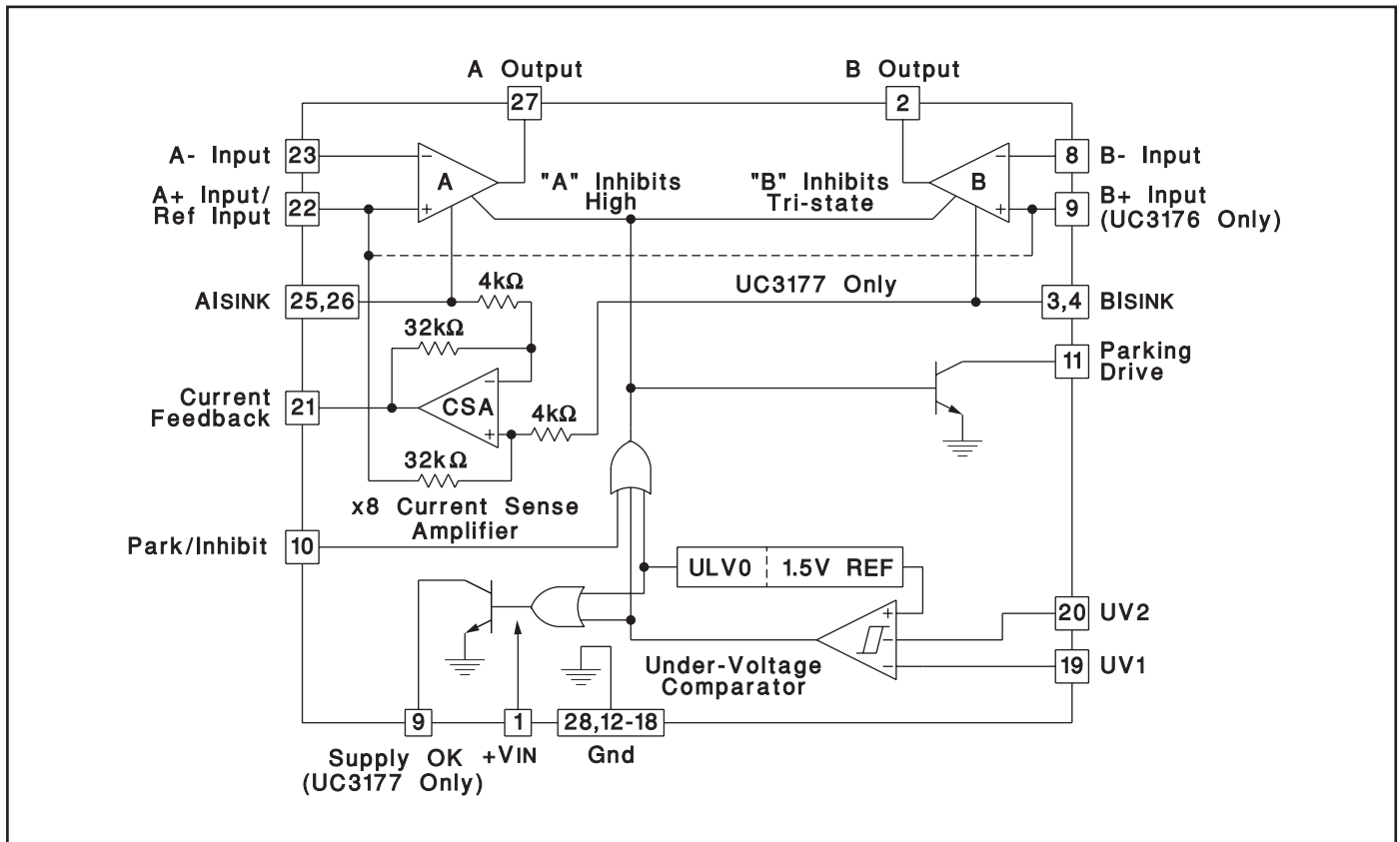

ABSOLUTE MAXIMUM RATINGS (Note 1)

Input Supply voltage, (+V _{IN})	40V
Park/Inhibit, UV1 and UV2 inputs (zener clamped)	
Maximum forced voltage	-0.3V to 10V
Maximum forced current	±10mA
Other Input Voltages	-0.3V to +V _{IN}
A _{SINK} and B _{SINK} Voltages	-0.3V to 6V
Open Collector Output Voltages	40V
A and B Output Currents (Continuous)	
Source	Internally Limited
Sink	2.5A
Total Supply Current (Continuous)	4A
Parking Drive Output Current (Continuous)	200mA
Supply OK Output Current, UC3177 (Continuous)	30mA
Operating Junction Temperature	-55°C to +150°C
Power Dissipation at TC = +75°C	
QP package	4W
Storage Temperature	-65°C to +150°C

THERMAL DATA

QP package:

Thermal Resistance Junction to Leads, θ_{JL}	15°C/W
Thermal Resistance Junction to Ambient, θ_{JA}	50°C/W
Thermal Resistance Junction to C _{OSC} , θ_{JC}	30°C/W

CONNECTION DIAGRAM

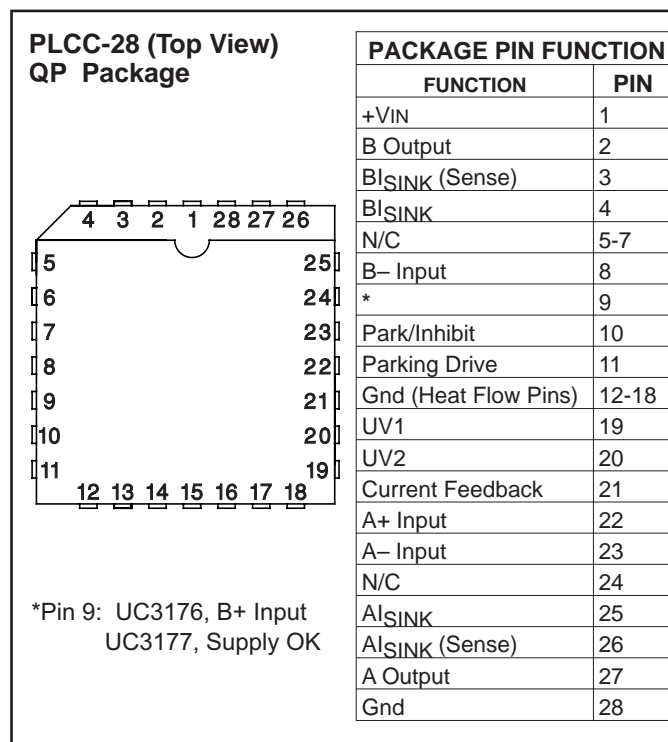

ELECTRICAL CHARACTERISTICS: Unless otherwise stated, specifications hold for T_A = 0 to 70°C, +V_{IN} = 12V, T_A = T_J.

PARAMETER	TEST CONDITIONS	MIN.	TYP.	MAX.	UNITS
Input Supply					
Supply Current	+V _{IN} = 12V		18	25	mA
	+V _{IN} = 35V		21	30	mA
UVOL Threshold	+V _{IN} low to high		2.8	3.0	V
	Threshold Hysteresis		220	300	mV
Power, Amplifier, A and B					
Input Offset Voltage	V _{CM} = 6V, V _{OUT} = 6V			8	mV
Input Bias Current	V _{CM} = 6V, Except A+ Input	-500	-100		nA
Input Bias Current at A+/Reference Input	(A+/REF - B _{SINK}) / 36kΩ; T _J = 25°C	23	28	35	μA/V
Input Offset Current B Amp (UC3176 Only)	V _{CM} = 6V			200	nA
CMRR	V _{CM} = 1 to 33V, +V _{IN} = 35V, V _{OUT} = 6V	70	100		dB
PSRR	+V _{IN} = 5 to 35V, V _{CM} = 2.5V	70	100		dB
Large Signal Voltage Gain	V _{OUT} = 3V, w/I _{OUT} = 1A to V _{OUT} = 9V, w/I _{OUT} = -1A	1.5	4		V/mV
Thermal Feedback	+V _{IN} = 20V, Pd = 20W at opposite output		25	200	μV/W
Saturation Voltage	I _{OUT} = -2A, High Side, T _J = 25°		1.9		V
	C _I _{OUT} = 2A, Low Side, T _J = 25°C		1.6		V
	Total V _{SAT} at 2A, T _J = 25°C		3.5	3.7	V
Unity Gain Bandwidth			1		MHz
Slew Rate			1		V/μs
Differential I _{OUT} Sense Error Current in Bridge Configuration	I _{OUT} (A) = -I _{OUT} (B), I _{OUT} / - / A _{SINK} - B _{SINK} /				
	I _{OUT} ≤ 200mA		3.0	6.0	mA
	I _{OUT} ≤ 2A		5.0	10	mA
High Side Current Limiting	=V _{IN} - V _{OUT} < 12V		-2.7	-2.0	A

ELECTRICAL CHARACTERISTICS: Unless otherwise stated, specifications hold for $T_A = 0$ to 70°C , $+V_{IN} = 12\text{V}$, $T_A = T_J$.

PARAMETER	TEST CONDITIONS	MIN.	TYP.	MAX.	UNITS
Current Sense Amplifier					
Input Offset Voltage	$V_{CM} = 0\text{V}$, A+ / REF at 6V			3	mV
	REF = 2V to 20V, $+V_{IN} = 35$, change with REF Input voltage			600	$\mu\text{V/V}$
Thermal Gradient Sensitivity	$+V_{IN} = 20\text{V}$, REF = 10V Pd = 20W @ A or B Output		5.0	75.0	$\mu\text{V/W}$
PSRR	REF = 2.5V, $+V_{IN} = 5$ to 35V	70	100		dB
Gain	$ A_{SINK-B} _{SINK} / \leq 0.5\text{V}$	7.8	8.0	8.1	V/V
Slew Rate			2		V/ μS
3dB Bandwidth			1		MHz
MAX Output Current	$I_{SOURCE} = +V_{IN} - V_{OUT} = 0.5\text{V}$	2.5	3.5		mA
Output Saturation Voltage	$I_{SOURCE} = 1.5\text{mA}$, High Side		0.15	0.30	V
	$I_{SINK} = 5\text{mA}$, Low Side		1.4	1.85	V
Under-Voltage Comparator					
Threshold Voltage	Low to High, other input at 5V	1.44	1.50	1.56	V
	Threshold Hysteresis	50	70	80	mV
Input Current	Input = 2V, other input at 5V	-2.00	-0.05		μA
Supply OK V_{SAT} (UC3177 Only)	$I_{OUT} = 5\text{mA}$			0.45	V
Supply OK Leakage (UC3177 Only)	$V_{OUT} = 35\text{V}$			5	μA
Park/Inhibit					
Park/Inhibit Th'l'd		1.1	1.3	1.7	V
Park/Inhibit Input Current	At threshold		60	100	μA
Parking Drive Saturation Voltage	$I_{OUT} = 100\text{mA}$		0.3	0.7	V
Parking Drive Leakage	$V_{OUT} = 35\text{V}$			15	μA
Thermal Shutdown					
Shutdown Temperature			165		$^\circ\text{C}$

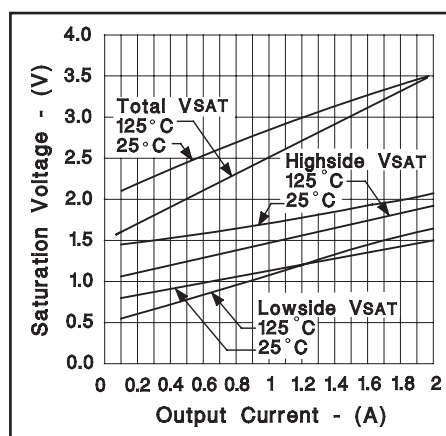

Output saturation voltage vs. current.

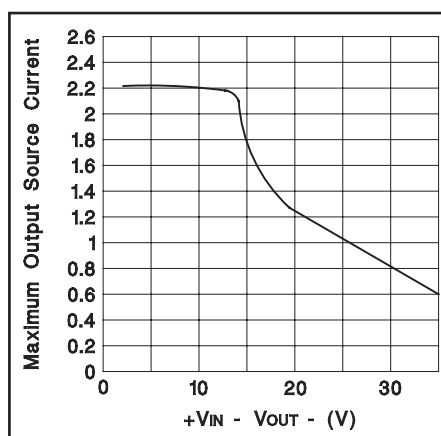

Maximum source current vs. $+V_{IN} - V_{OUT}$.

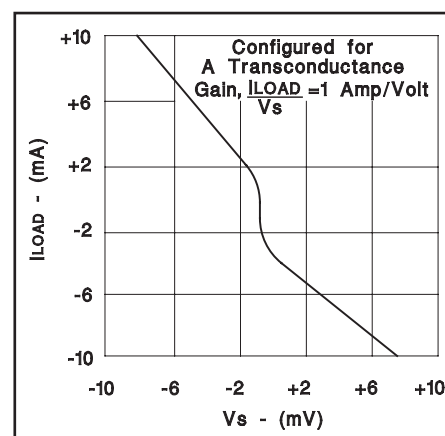

Crossover current error characteristic.

APPLICATION AND OPERATION INFORMATION

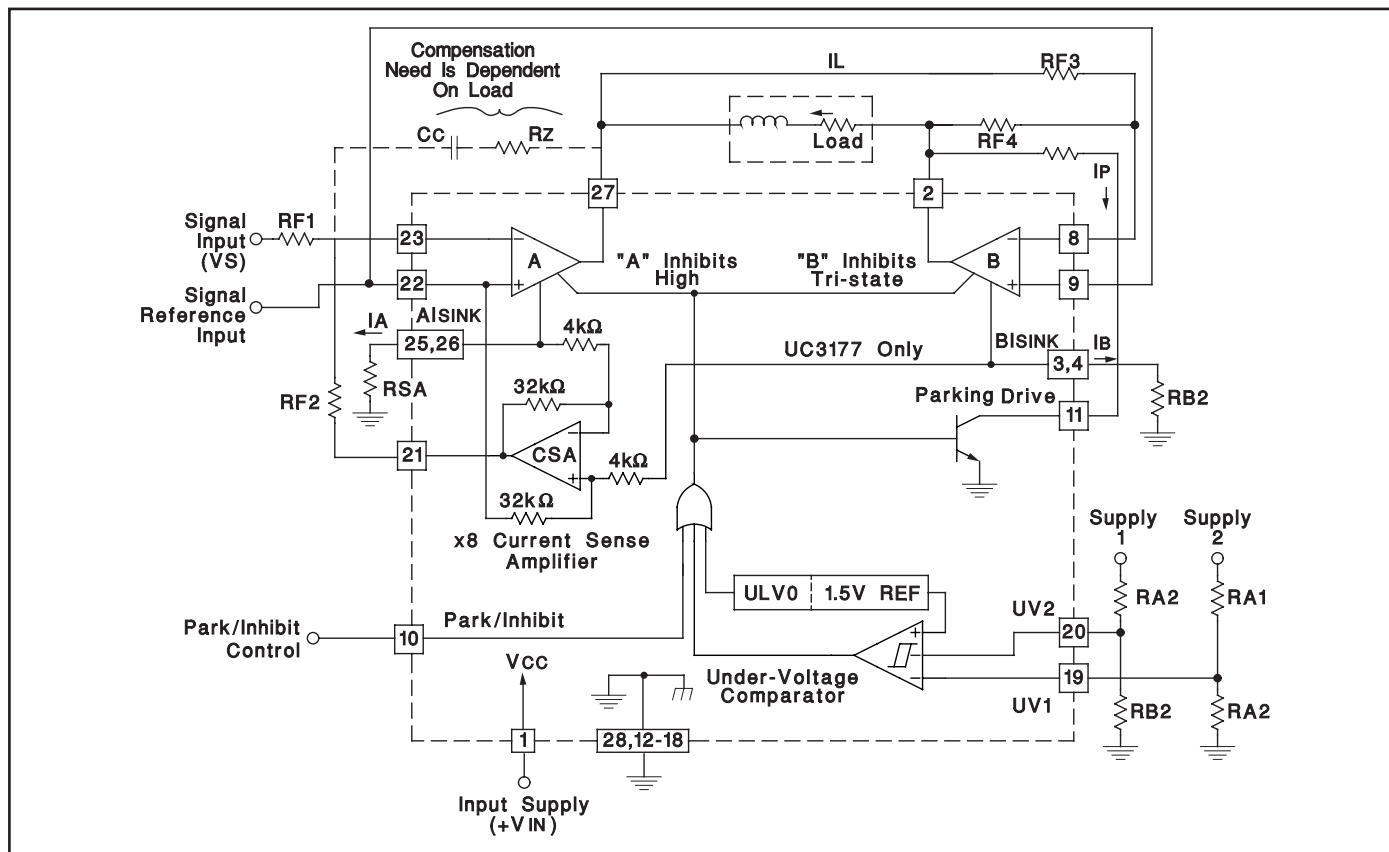

WAVEFORMS FOR ABOVE APPLICATION

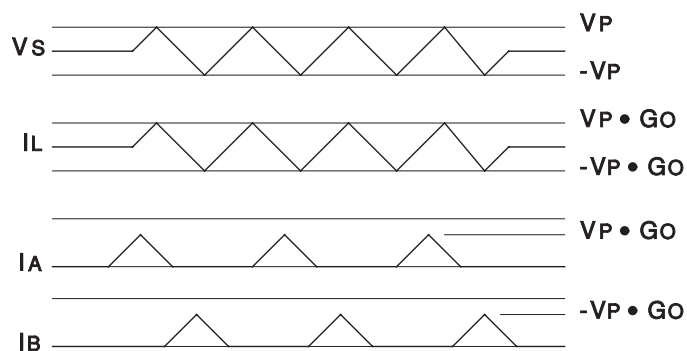

DESIGN EQUATIONS

$$\text{Transconductance } (G_O) = \frac{I_L}{V_S} = \frac{R_{F2}}{R_{F1}} \times \left(\frac{1}{8R_S} \right)$$

with: $R_{SA} = R_{SB}$ and $R_{F3} = R_{F4}$

$$\text{Parking Current } (I_P) = \frac{V_{IN} - 1.5}{R_P + R_L}$$

where: R_L = load resistance

Under-Voltage Thresholds, at Supplies
 High to Low Threshold, $(V_{LH}) = 1.425 (R_A + R_B)/R_B$
 Low to High Threshold, $(V_{HL}) = 1.5 (R_A + R_B)/R_B$

PACKAGING INFORMATION

Orderable Device	Status (1)	Package Type	Package Drawing	Pins	Package Qty	Eco Plan (2)	Lead/Ball Finish (6)	MSL Peak Temp (3)	Op Temp (°C)	Device Marking (4/5)	Samples
UC3176QP	NRND	PLCC	FN	28	37	Green (RoHS & no Sb/Br)	CU NIPDAU	Level-3-260C-168 HR	0 to 70	UC3176QP	
UC3176QPTR	NRND	PLCC	FN	28	750	Green (RoHS & no Sb/Br)	CU NIPDAU	Level-3-260C-168 HR	0 to 70	UC3176QP	

(1) The marketing status values are defined as follows:

ACTIVE: Product device recommended for new designs.

LIFEBUY: TI has announced that the device will be discontinued, and a lifetime-buy period is in effect.

NRND: Not recommended for new designs. Device is in production to support existing customers, but TI does not recommend using this part in a new design.

PREVIEW: Device has been announced but is not in production. Samples may or may not be available.

OBSOLETE: TI has discontinued the production of the device.

(2) **RoHS:** TI defines "RoHS" to mean semiconductor products that are compliant with the current EU RoHS requirements for all 10 RoHS substances, including the requirement that RoHS substance do not exceed 0.1% by weight in homogeneous materials. Where designed to be soldered at high temperatures, "RoHS" products are suitable for use in specified lead-free processes. TI may reference these types of products as "Pb-Free".

RoHS Exempt: TI defines "RoHS Exempt" to mean products that contain lead but are compliant with EU RoHS pursuant to a specific EU RoHS exemption.

Green: TI defines "Green" to mean the content of Chlorine (Cl) and Bromine (Br) based flame retardants meet JS709B low halogen requirements of <=1000ppm threshold. Antimony trioxide based flame retardants must also meet the <=1000ppm threshold requirement.

(3) MSL, Peak Temp. - The Moisture Sensitivity Level rating according to the JEDEC industry standard classifications, and peak solder temperature.

(4) There may be additional marking, which relates to the logo, the lot trace code information, or the environmental category on the device.

(5) Multiple Device Markings will be inside parentheses. Only one Device Marking contained in parentheses and separated by a "~" will appear on a device. If a line is indented then it is a continuation of the previous line and the two combined represent the entire Device Marking for that device.

(6) Lead/Ball Finish - Orderable Devices may have multiple material finish options. Finish options are separated by a vertical ruled line. Lead/Ball Finish values may wrap to two lines if the finish value exceeds the maximum column width.

Important Information and Disclaimer:The information provided on this page represents TI's knowledge and belief as of the date that it is provided. TI bases its knowledge and belief on information provided by third parties, and makes no representation or warranty as to the accuracy of such information. Efforts are underway to better integrate information from third parties. TI has taken and continues to take reasonable steps to provide representative and accurate information but may not have conducted destructive testing or chemical analysis on incoming materials and chemicals. TI and TI suppliers consider certain information to be proprietary, and thus CAS numbers and other limited information may not be available for release.

In no event shall TI's liability arising out of such information exceed the total purchase price of the TI part(s) at issue in this document sold by TI to Customer on an annual basis.

FN 28

GENERIC PACKAGE VIEW

PLCC - 4.57 mm max height

PLASTIC CHIP CARRIER



Images above are just a representation of the package family, actual package may vary.
Refer to the product data sheet for package details.

4040005-3/C



PACKAGE OUTLINE

FN0028A

PLCC - 4.57 mm max height

PLASTIC CHIP CARRIER

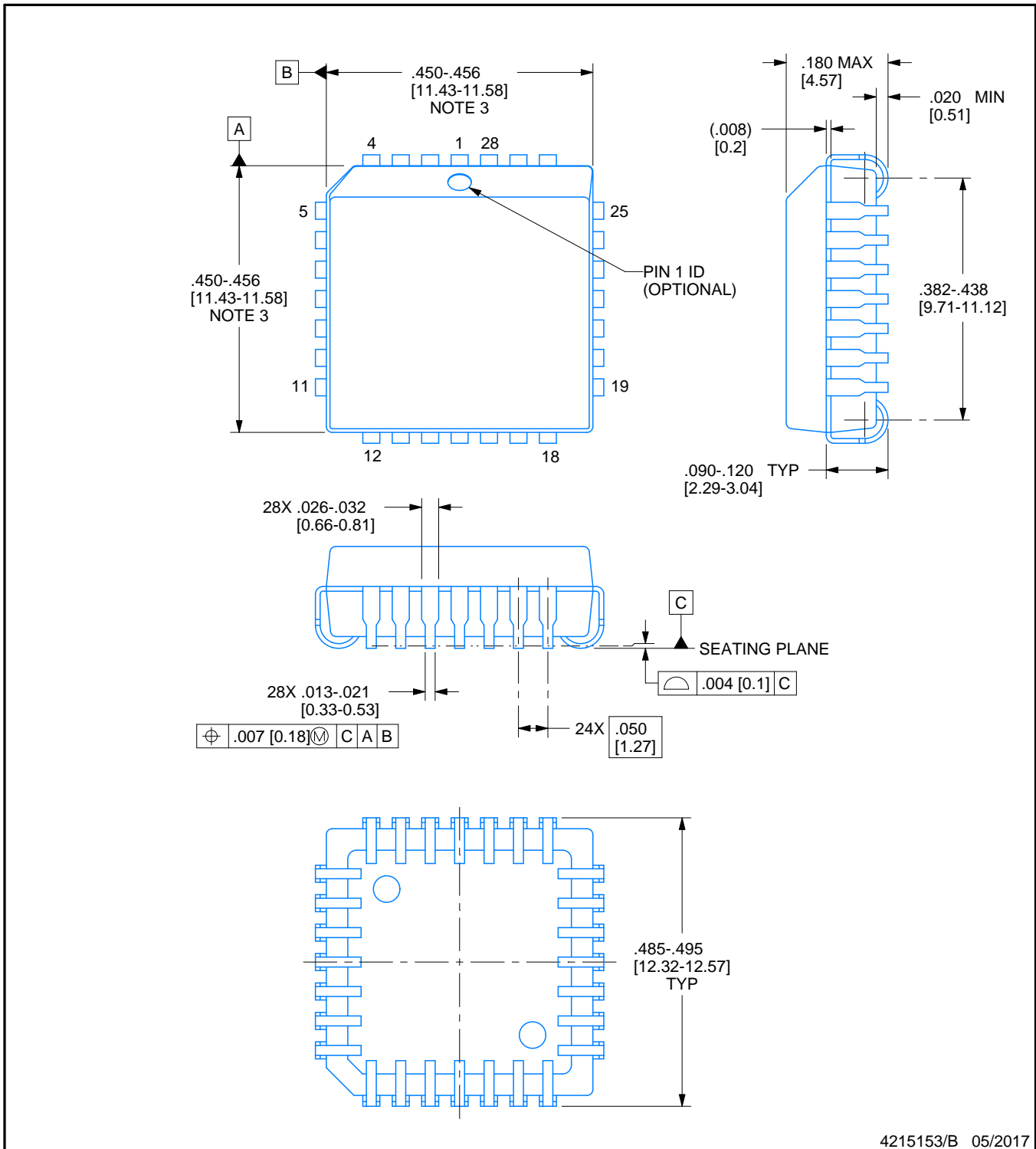

4215153/B 05/2017

NOTES:

1. All linear dimensions are in inches. Any dimensions in brackets are in millimeters. Any dimensions in parenthesis are for reference only. Controlling dimensions are in inches. Dimensioning and tolerancing per ASME Y14.5M.
2. This drawing is subject to change without notice.
3. Dimension does not include mold protrusion. Maximum allowable mold protrusion .01 in [0.25 mm] per side.
4. Reference JEDEC registration MS-018.

EXAMPLE BOARD LAYOUT

FN0028A

PLCC - 4.57 mm max height

PLASTIC CHIP CARRIER

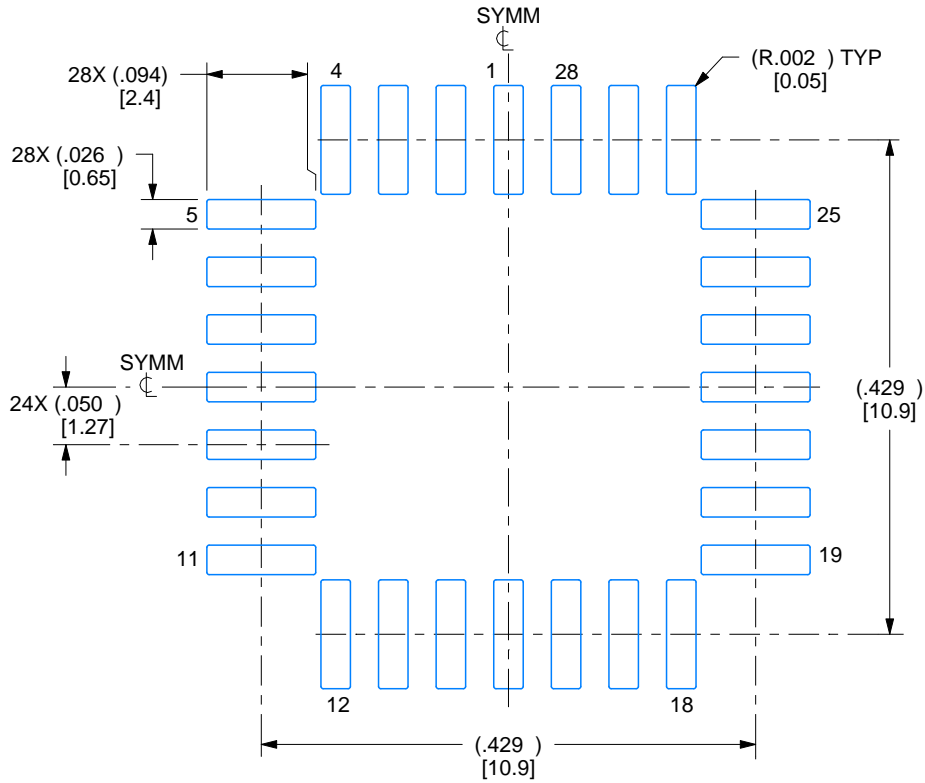

LAND PATTERN EXAMPLE
EXPOSED METAL SHOWN
SCALE:6X

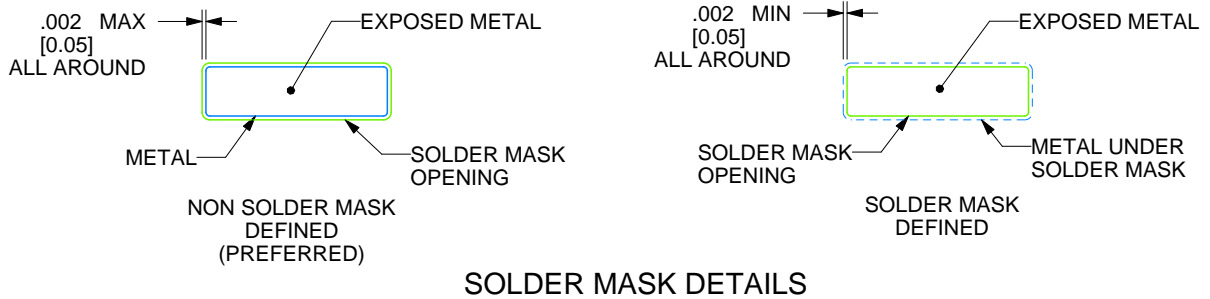

4215153/B 05/2017

NOTES: (continued)

- 5. Publication IPC-7351 may have alternate designs.
- 6. Solder mask tolerances between and around signal pads can vary based on board fabrication site.

EXAMPLE STENCIL DESIGN

FN0028A

PLCC - 4.57 mm max height

PLASTIC CHIP CARRIER

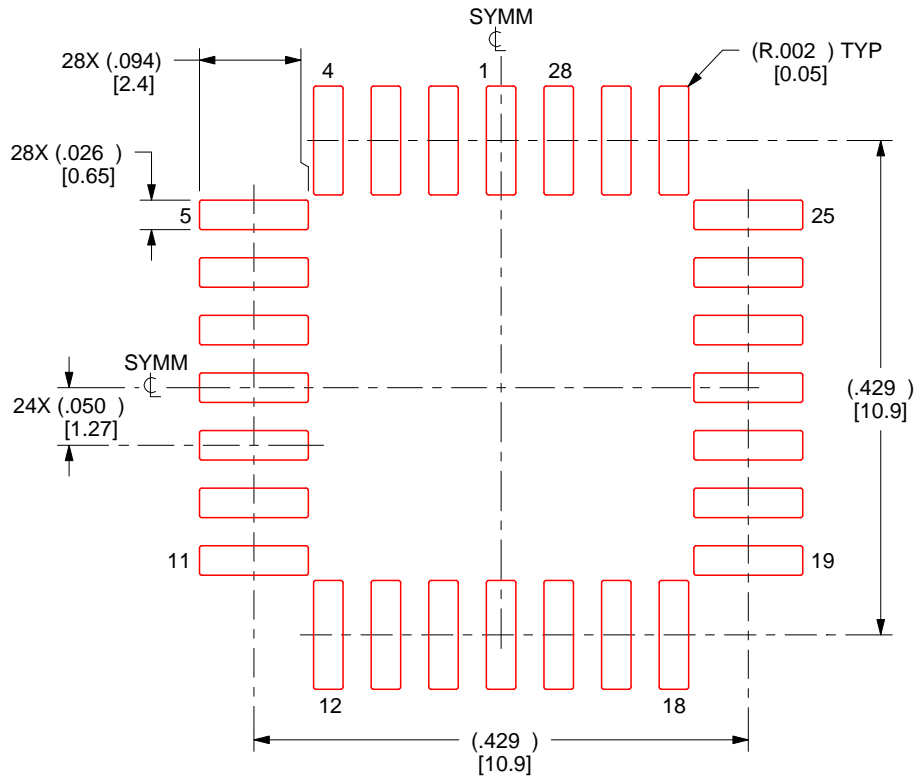

4215153/B 05/2017

NOTES: (continued)

7. Laser cutting apertures with trapezoidal walls and rounded corners may offer better paste release. IPC-7525 may have alternate design recommendations.
8. Board assembly site may have different recommendations for stencil design.

IMPORTANT NOTICE

Texas Instruments Incorporated (TI) reserves the right to make corrections, enhancements, improvements and other changes to its semiconductor products and services per JESD46, latest issue, and to discontinue any product or service per JESD48, latest issue. Buyers should obtain the latest relevant information before placing orders and should verify that such information is current and complete.

TI's published terms of sale for semiconductor products (<http://www.ti.com/sc/docs/stdterms.htm>) apply to the sale of packaged integrated circuit products that TI has qualified and released to market. Additional terms may apply to the use or sale of other types of TI products and services.

Reproduction of significant portions of TI information in TI data sheets is permissible only if reproduction is without alteration and is accompanied by all associated warranties, conditions, limitations, and notices. TI is not responsible or liable for such reproduced documentation. Information of third parties may be subject to additional restrictions. Resale of TI products or services with statements different from or beyond the parameters stated by TI for that product or service voids all express and any implied warranties for the associated TI product or service and is an unfair and deceptive business practice. TI is not responsible or liable for any such statements.

Buyers and others who are developing systems that incorporate TI products (collectively, "Designers") understand and agree that Designers remain responsible for using their independent analysis, evaluation and judgment in designing their applications and that Designers have full and exclusive responsibility to assure the safety of Designers' applications and compliance of their applications (and of all TI products used in or for Designers' applications) with all applicable regulations, laws and other applicable requirements. Designer represents that, with respect to their applications, Designer has all the necessary expertise to create and implement safeguards that (1) anticipate dangerous consequences of failures, (2) monitor failures and their consequences, and (3) lessen the likelihood of failures that might cause harm and take appropriate actions. Designer agrees that prior to using or distributing any applications that include TI products, Designer will thoroughly test such applications and the functionality of such TI products as used in such applications.

TI's provision of technical, application or other design advice, quality characterization, reliability data or other services or information, including, but not limited to, reference designs and materials relating to evaluation modules, (collectively, "TI Resources") are intended to assist designers who are developing applications that incorporate TI products; by downloading, accessing or using TI Resources in any way, Designer (individually or, if Designer is acting on behalf of a company, Designer's company) agrees to use any particular TI Resource solely for this purpose and subject to the terms of this Notice.

TI's provision of TI Resources does not expand or otherwise alter TI's applicable published warranties or warranty disclaimers for TI products, and no additional obligations or liabilities arise from TI providing such TI Resources. TI reserves the right to make corrections, enhancements, improvements and other changes to its TI Resources. TI has not conducted any testing other than that specifically described in the published documentation for a particular TI Resource.

Designer is authorized to use, copy and modify any individual TI Resource only in connection with the development of applications that include the TI product(s) identified in such TI Resource. NO OTHER LICENSE, EXPRESS OR IMPLIED, BY ESTOPPEL OR OTHERWISE TO ANY OTHER TI INTELLECTUAL PROPERTY RIGHT, AND NO LICENSE TO ANY TECHNOLOGY OR INTELLECTUAL PROPERTY RIGHT OF TI OR ANY THIRD PARTY IS GRANTED HEREIN, including but not limited to any patent right, copyright, mask work right, or other intellectual property right relating to any combination, machine, or process in which TI products or services are used. Information regarding or referencing third-party products or services does not constitute a license to use such products or services, or a warranty or endorsement thereof. Use of TI Resources may require a license from a third party under the patents or other intellectual property of the third party, or a license from TI under the patents or other intellectual property of TI.

TI RESOURCES ARE PROVIDED "AS IS" AND WITH ALL FAULTS. TI DISCLAIMS ALL OTHER WARRANTIES OR REPRESENTATIONS, EXPRESS OR IMPLIED, REGARDING RESOURCES OR USE THEREOF, INCLUDING BUT NOT LIMITED TO ACCURACY OR COMPLETENESS, TITLE, ANY EPIDEMIC FAILURE WARRANTY AND ANY IMPLIED WARRANTIES OF MERCHANTABILITY, FITNESS FOR A PARTICULAR PURPOSE, AND NON-INFRINGEMENT OF ANY THIRD PARTY INTELLECTUAL PROPERTY RIGHTS. TI SHALL NOT BE LIABLE FOR AND SHALL NOT DEFEND OR INDEMNIFY DESIGNER AGAINST ANY CLAIM, INCLUDING BUT NOT LIMITED TO ANY INFRINGEMENT CLAIM THAT RELATES TO OR IS BASED ON ANY COMBINATION OF PRODUCTS EVEN IF DESCRIBED IN TI RESOURCES OR OTHERWISE. IN NO EVENT SHALL TI BE LIABLE FOR ANY ACTUAL, DIRECT, SPECIAL, COLLATERAL, INDIRECT, PUNITIVE, INCIDENTAL, CONSEQUENTIAL OR EXEMPLARY DAMAGES IN CONNECTION WITH OR ARISING OUT OF TI RESOURCES OR USE THEREOF, AND REGARDLESS OF WHETHER TI HAS BEEN ADVISED OF THE POSSIBILITY OF SUCH DAMAGES.

Unless TI has explicitly designated an individual product as meeting the requirements of a particular industry standard (e.g., ISO/TS 16949 and ISO 26262), TI is not responsible for any failure to meet such industry standard requirements.

Where TI specifically promotes products as facilitating functional safety or as compliant with industry functional safety standards, such products are intended to help enable customers to design and create their own applications that meet applicable functional safety standards and requirements. Using products in an application does not by itself establish any safety features in the application. Designers must ensure compliance with safety-related requirements and standards applicable to their applications. Designer may not use any TI products in life-critical medical equipment unless authorized officers of the parties have executed a special contract specifically governing such use. Life-critical medical equipment is medical equipment where failure of such equipment would cause serious bodily injury or death (e.g., life support, pacemakers, defibrillators, heart pumps, neurostimulators, and implantables). Such equipment includes, without limitation, all medical devices identified by the U.S. Food and Drug Administration as Class III devices and equivalent classifications outside the U.S.

TI may expressly designate certain products as completing a particular qualification (e.g., Q100, Military Grade, or Enhanced Product). Designers agree that it has the necessary expertise to select the product with the appropriate qualification designation for their applications and that proper product selection is at Designers' own risk. Designers are solely responsible for compliance with all legal and regulatory requirements in connection with such selection.

Designer will fully indemnify TI and its representatives against any damages, costs, losses, and/or liabilities arising out of Designer's non-compliance with the terms and provisions of this Notice.

Looking for pricing, stock, or lifecycle information?

Click below to explore more details on WIN SOURCE:

 [View UC3176QP](#) on WIN SOURCE

 [Texas Instruments](#) Information

Optimize Your Supply Chain with WIN SOURCE Solutions

-  Global Sourcing Solution
-  Obsolete Management
-  Cost Control Management
-  Shortage Management
-  Alternative Solution
-  Excess Inventory Management