



THE DATASHEET OF UCC284DPTR-ADJ





- Precision Negative Series Pass Voltage Regulation
- 0.2 V Dropout at 0.5 A
- Wide Input Voltage Range –3.2 V to –15 V
- Low Quiescent Current Irrespective of Load
- Simple Logic Shutdown Interfacing
- –5 V, –12 V, and Adjustable Output
- 2.5% Duty Cycle Short Circuit Protection

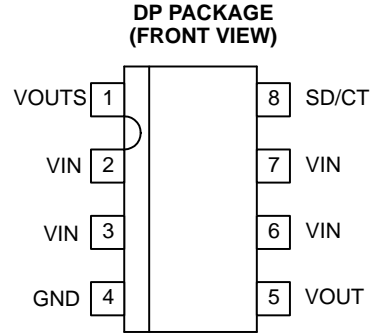

description

The UCC384-x family of negative linear-series pass regulators is tailored for low-dropout applications where low-quiescent power is important. Fabricated with a BCDMOS technology ideally suited for low input-to-output differential applications, the UCC384-x passes 0.5 A while requiring only 0.2 V of input-voltage headroom. Dropout voltage decreases linearly with output current, so that dropout at 50 mA is less than 20 mV.

Quiescent current consumption for the device under normal (non-dropout) conditions is typically 200 μ A. An integrated charge pump is internally enabled only when the device is operating near dropout with low V_{IN} . This ensured that the device meets the dropout specifications even for maximum load current and a V_{IN} of –3.2 V with only a modest increase in quiescent current. Quiescent current is always less than 350 μ A, with the charge pump enabled. The quiescent current of the UCC384 does not increase with load current.

Short-circuit current is internally limited. The device responds to a sustained overcurrent condition by turning off after a t_{ON} delay. The device then stays off for a period, t_{OFF} , that is 40 times the t_{ON} delay. The device then begins pulsing on and off at the t_{ON}/t_{OFF} duty cycle of 2.5%. This drastically reduces the power dissipation during short circuit such that heat sinking, if at all required, must only accommodate normal operation. An external capacitor sets the on time. The off time is always 40 times t_{ON} .

The UCCx84-x can be shutdown to 45 μ A (maximum) by pulling the SD/CT pin more positive than –0.7 V. To allow for simpler interfacing, the SD/CT pin may be pulled up to 6 V above the ground pin without turning on clamping diodes.

Internal power dissipation is further controlled with thermal-overload protection circuitry. Thermal shutdown occurs if the junction temperature exceeds 140°C. The chip remains off until the temperature has dropped 20°C ($T_J = 120^\circ\text{C}$).

AVAILABLE OPTIONS

T_A	OUTPUT VOLTAGE (V)	PACKAGE DEVICES
	TYP	(SOIC) DP
–40°C to 85°C	–5	UCC284DP–5
	–12	UCC284DP–12
	ADJ	UCC284DP–ADJ
0°C to 70°C	–5	UCC384DP–5
	–12	UCC384DP–12
	ADJ	UCC384DP–ADJ

† All package types are available taped and reeled. Add TR suffix to device type (e.g. UCC284DP–5TR) to order quantities of 3000 devices per reel.



Please be aware that an important notice concerning availability, standard warranty, and use in critical applications of Texas Instruments semiconductor products and disclaimers thereto appears at the end of this data sheet.

UCC284-5, UCC284-12, UCC284-ADJ, UCC384-5, UCC384-12, UCC384-ADJ LOW-DROPOUT 0.5-A NEGATIVE LINEAR REGULATOR

SLUS234D – JANUARY 2000 – REVISED FEBRUARY 2002

functional block diagram

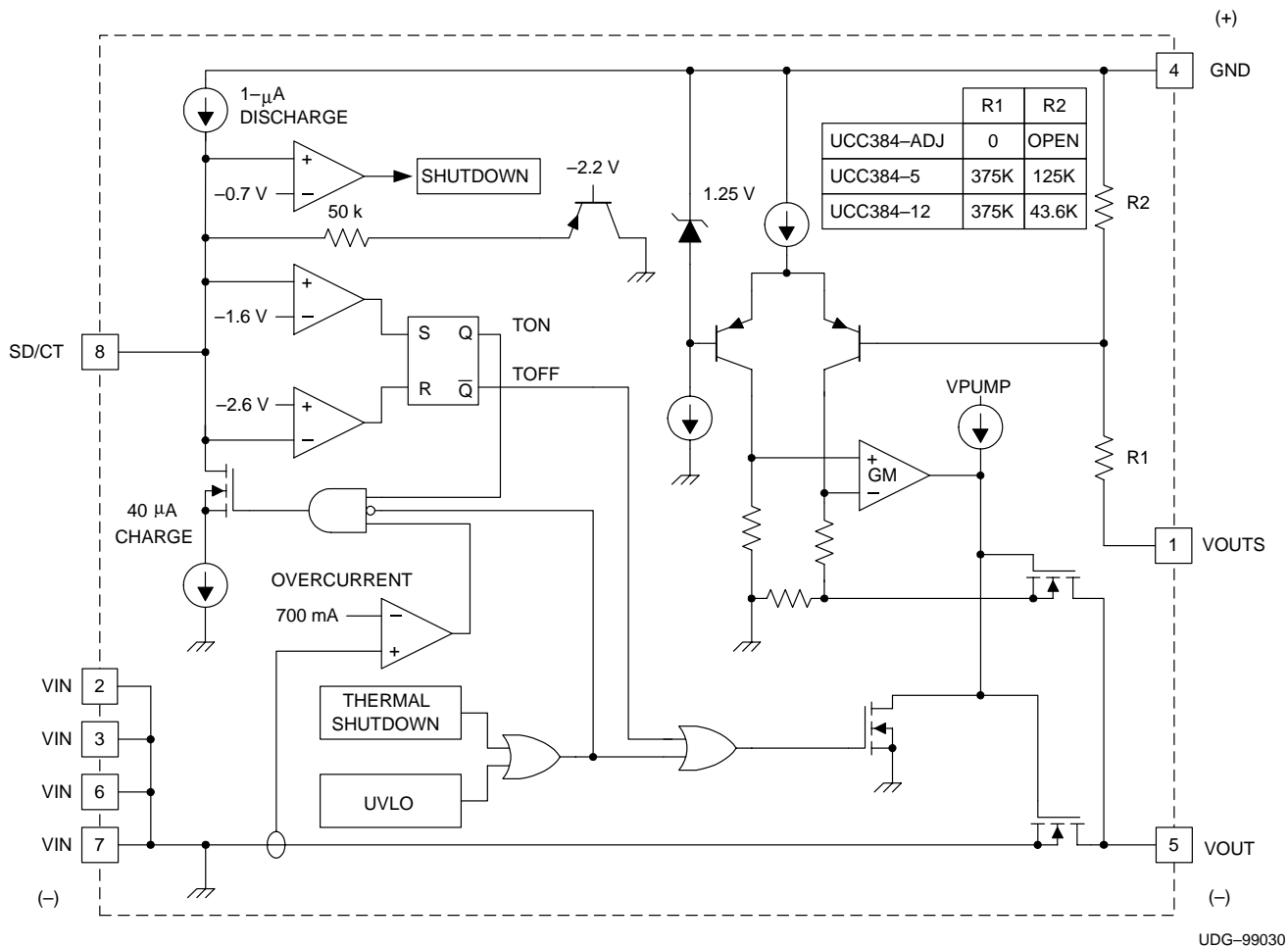

absolute maximum ratings over operating free-air temperature (unless otherwise noted)^{†‡}

Input voltage range [‡] , V_{IN}	-16 V
Shutdown voltage range, SD/CT	-5 V to 6 V
Operating virtual junction temperature range, T_J	-55°C to 150°C
Storage temperature range T_{stg}	-65°C to 150°C
Lead temperature (Soldering, 10 seconds)	300°C

[†] Stresses beyond those listed under “absolute maximum ratings” may cause permanent damage to the device. These are stress ratings only, and functional operation of the device at these or any other conditions beyond those indicated under “recommended operating conditions” is not implied. Exposure to absolute-maximum-rated conditions for extended periods may affect device reliability.

[‡] All voltages are with respect to ground. Currents are positive into and negative out of the specified terminals.



UCC284-5, UCC284-12, UCC284-ADJ, UCC384-5, UCC384-12, UCC384-ADJ LOW-DROPOUT 0.5-A NEGATIVE LINEAR REGULATOR

SLUS234D – JANUARY 2000 – REVISED FEBRUARY 2002

electrical characteristics $T_A = 0^\circ\text{C}$ to 70°C for the UCC384 and -40°C to 85°C for the UCC284, $V_{IN} = V_{OUT} - 1.5\text{ V}$, $I_{OUT} = 0\text{ mA}$, $C_{OUT} = 4.7\ \mu\text{F}$, and $C_T = 0.015\ \mu\text{F}$. For UCC384-ADJ, V_{OUT} is set to -3.3V (unless otherwise noted)

PARAMETER	TEST CONDITIONS	MIN	TYP	MAX	UNIT
UCC384-5 Fixed -5-V 0.5-A Regulation Section					
Output voltage	$T_A = 25^\circ\text{C}$	-5.075	-5	-4.925	V
	Over all conditions	-5.100		-4.850	V
Line regulation	$V_{IN} = -5.2\text{ V}$ to -15 V		1.5	10	mV
Load regulation	$I_{OUT} = 0\text{ mA}$ to 0.5 A		0.1	0.25	%
Output noise voltage	$T_A = 25^\circ\text{C}$, BW = 10 Hz to 10 kHz		200		μVRMS
Dropout voltage, $V_{OUT} - V_{IN}$	$I_{OUT} = 0.5\text{ A}$, $V_{OUT} = -4.8\text{ V}$		0.20	0.50	V
	$I_{OUT} = 50\text{ mA}$, $V_{OUT} = -4.8\text{ V}$		20	50	mV
UCC384-5 Fixed -5-V 0.5-A Power Supply Section					
Input voltage range		-15		-5.2	V
Quiescent current charge pump on	$V_{IN} = -4.85\text{ V}$, See Note 1		280	350	μA
Quiescent current	$V_{IN} = -15\text{ V}$		200	250	μA
Quiescent current in shutdown	$V_{IN} = -13\text{ V}$, $SD/CT = 0\text{ V}$, $T_A = 0^\circ\text{C}$ to 85°C , See Note 2		15	45	μA
	$V_{IN} = -13\text{ V}$, $SD/CT = 0\text{ V}$, $T_A = -40^\circ\text{C}$ to 0°C , See Note 2			100	μA
Shutdown threshold	At shutdown pin (SD/CT)	-1.0	-0.7	-0.4	V
Shutdown input current	$SD/CT = 0\text{ V}$	5	10	25	μA
Output leakage in shutdown	$V_{IN} = -15\text{ V}$, $V_{OUT} = 0\text{ V}$, See Note 3		1	50	μA
Overtemperature shutdown			140		$^\circ\text{C}$
Overtemperature hysteresis			20		$^\circ\text{C}$
UCC384-5 Fixed -5-V 0.5-A Current Limit Section					
Peak current limit	$V_{OUT} = 0\text{ V}$	0.7	1.1	1.5	A
Overcurrent threshold		0.55	0.7	0.9	A
Current limit duty cycle	$V_{OUT} = 0\text{ V}$		2.5	4	%
Overcurrent time out, t_{ON}	$V_{OUT} = 0\text{ V}$	300	500	700	μs
UCC384-12 Fixed 12-V 0.5-A Regulation Section					
Output voltage	$T_A = 25^\circ\text{C}$	-12.18	-12	-11.82	V
	Over all conditions	-12.24		-11.64	V
Line regulation	$V_{IN} = -12.5\text{ V}$ to -15 V		5	15	mV
Load regulation	$I_{OUT} = 0\text{ mA}$ to 0.5 A		0.1	0.3	%
Output noise voltage	$T_A = 25^\circ\text{C}$ BW = 10 Hz to 10 kHz		200		μVRMS
Dropout voltage, $V_{OUT} - V_{IN}$	$I_{OUT} = 0.5\text{ A}$, $V_{OUT} = -11.6\text{ V}$		0.15	0.5	V
	$I_{OUT} = 50\text{ mA}$, $V_{OUT} = -11.6\text{ V}$		15	50	mV
UCC384-12 Fixed -12 V-0.5-A Power Supply Section					
Input voltage range		-15		-12.5	V
Quiescent current	$V_{IN} = -15\text{ V}$		220	350	μA
Quiescent current in shutdown	$V_{IN} = -13\text{ V}$, $SD/CT = 0\text{ V}$, $T_A = 0^\circ\text{C}$ to 85°C , See Note 2		15	45	μA
	$V_{IN} = -13\text{ V}$, $SD/CT = 0\text{ V}$, $T_A = -40^\circ\text{C}$ to 0°C , See Note 2			100	μA

- NOTES: 1. The internal charge pump is enabled only for dropout condition with low V_{IN} . Only in this condition is the charge pump required to provide additional output FET gate drive to maintain dropout specifications. For conditions where the charge pump is not required, it is disabled, which lowers overall device power consumption.
2. Ensured by design. Not production tested.
3. In the application during shutdown mode, output leakage current adds to quiescent current.



UCC284-5, UCC284-12, UCC284-ADJ, UCC384-5, UCC384-12, UCC384-ADJ LOW-DROPOUT 0.5-A NEGATIVE LINEAR REGULATOR

SLUS234D – JANUARY 2000 – REVISED FEBRUARY 2002

electrical characteristics $T_A = 0^\circ\text{C}$ to 70°C for the UCC384 and -40°C to 85°C for the UCC284, $V_{IN} = V_{OUT} - 1.5\text{ V}$, $I_{OUT} = 0\text{ mA}$, $C_{OUT} = 4.7\text{ }\mu\text{F}$, and $C_T = 0.015\text{ }\mu\text{F}$. For UCC384-ADJ, V_{OUT} is set to -3.3 V (unless otherwise noted)

PARAMETER	TEST CONDITIONS	MIN	TYP	MAX	UNIT
UCC384-12 Fixed -12 V-0.5-A Power Supply Section (continued)					
Shutdown threshold	At shutdown pin (SD/CT)	-1.0	-0.7	-0.4	V
Shutdown input current	SD/CT = 0 V	5	10	25	μA
Output leakage in shutdown	$V_{IN} = -15\text{ V}$, See Note 3 $V_{OUT} = 0\text{ V}$,		1	50	μA
Overtemperature shutdown			140		$^\circ\text{C}$
Overtemperature hysteresis			20		$^\circ\text{C}$
UCC384-12 Fixed -12-V 0.5-A Current Limit Section					
Peak current limit	$V_{OUT} = 0\text{ V}$	0.7	1.1	1.5	A
Overcurrent threshold		0.55	0.7	0.9	A
Current limit duty cycle	$V_{OUT} = 0\text{ V}$		2.5	4	%
Overcurrent time out, t_{ON}	$V_{OUT} = 0\text{ V}$	300	500	700	μs
UCC384-ADJ Adjustable 0.5-A Regulation Section					
Reference voltage	$T_A = 25^\circ\text{C}$	-1.27	-1.25	-1.23	V
	Over temperature	-1.275		-1.215	V
Line regulation	$V_{IN} = -3.5\text{ V}$ to -15 V , $V_{OUT} = V_{OUTS}$		0.5	3	mV
Load regulation	$I_{OUT} = 0\text{ mA}$ to 0.5 A		0.1	0.18	%
Output noise voltage	BW = 10 Hz to 10 kHz, $T_A = 25^\circ\text{C}$		200		μVRMS
Dropout voltage, $V_{OUT} - V_{IN}$	$I_{OUT} = 0.5\text{ A}$, $V_{OUT} = -3.15\text{ V}$		0.25	0.5	V
	$I_{OUT} = 50\text{ mA}$, $V_{OUT} = -3.15\text{ V}$		25	50	mV
Sense pin input current			100	250	nA
UCC384-ADJ Adjustable 0.5-A Power Supply Section					
Input voltage range		-15		-3.5	V
Undervoltage lockout		-3.2	-2.95	-2.7	V
Quiescent current charge pump on	$V_{IN} = -3.15\text{ V}$, See Note 1		200	350	μA
Quiescent current	$V_{IN} = -15\text{ V}$		200	250	μA
Quiescent current in shutdown	$V_{IN} = -13\text{ V}$, $T_A = 0^\circ\text{C}$ to 85°C , SD/CT = 0 V See Note 2		15	45	μA
	$V_{IN} = -13\text{ V}$, $T_A = -40^\circ\text{C}$ to 0°C , SD/CT = 0 V See Note 2			100	μA
Shutdown threshold	At shutdown pin (SD/CT)	-1.0	-0.7	-0.4	V
Shutdown input current	SD/CT = 0V	5	10	25	μA
Output leakage in shutdown	$V_{IN} = -15\text{ V}$, See Note 3 $V_{OUT} = 0\text{ V}$,		1	50	μA
Overtemperature shutdown			140		$^\circ\text{C}$
Overtemperature hysteresis			20		$^\circ\text{C}$
UCC384-ADJ Adjustable 0.5-A Current Limit Section					
Peak current limit	$V_{OUT} = 0\text{ V}$	0.7	1.1	1.5	A
Overcurrent threshold		0.55	0.7	0.9	A
Current limit duty cycle	$V_{OUT} = 0\text{ V}$		2.5	4	%
Overcurrent time out, t_{ON}	$V_{OUT} = 0\text{ V}$	300	500	700	μs

- NOTES: 1. The internal charge pump is enabled only for dropout condition with low V_{IN} . Only in this condition is the charge pump required to provide additional output FET gate drive to maintain dropout specifications. For conditions where the charge pump is not required, it is disabled, which lowers overall device power consumption.
2. Ensured by design. Not production tested.
3. In the application during shutdown mode, output leakage current adds to quiescent current.



pin descriptions

GND: This is the low noise ground reference input. All voltages are measured with respect to the GND pin.

SD/CT: This is the shutdown pin and also the short-circuit timing pin. Pulling this pin more positive than -0.7 V puts the circuit in a low-current shutdown mode. Placing a timing capacitor between this pin and GND sets the short-circuit charging time, t_{ON} during an overcurrent condition. During an overcurrent condition, the output pulses at approximately a 2.5% duty cycle.

NOTE: The CT capacitor must be connected between this pin and GND, not VIN, to assure that the SD/CT pin is not pulled significantly negative during power-up. This pin should not be externally driven more negative than -5 V or the device will be damaged.

VIN: This is the negative input supply. Bypass this pin to GND with at least $1\text{ }\mu\text{F}$ of low ESR or ESL capacitance.

VOUT: Regulated negative-output voltage. A single $4.7\text{-}\mu\text{F}$ capacitor should be connected between this pin and GND. Smaller value capacitors can be used for light loads, but this degrades the load-step performance of the regulator.

VOULTS: This is the feedback pin for sensing the output of the regulator. For the UCC384-5 and UCC384-12 versions, VOULTS can be connected directly to VOUT. If the load is placed at a considerable distance from the regulator, the VOULTS lead can be used as a Kelvin connection to minimize errors due to lead resistance. Connecting VOULTS at the load moves the resistance of the VOUT wire into the control loop of the regulator, thereby effectively canceling the IR drop associated with the load path.

APPLICATION INFORMATION

overview

The UCCx84-x family of **negative** low-dropout linear (LDO) regulators provides a regulated-output voltage for applications with up to 0.5 A of load current. The regulators feature a low-dropout voltage and short-circuit protection, making their use ideal for demanding applications requiring fault protection.

programming the output voltage on the UCC384

The UCC384-5 and UCC384-12 have output voltages that are fixed at -5 V and -12 V respectively. Connecting VOULTS to VOUT gives the proper output voltage with respect to ground.

The UCC384-ADJ can be programmed for any output voltage between -1.25 V and -15 V . This is easily accomplished with the addition of an external resistor divider connected between GND and VOUT with VOULTS connected to the center tap of the divider. For an output of -1.25 V , no resistors are needed and VOULTS is connected directly to VOUT. The regulator-input voltage cannot be more positive than the UVLO threshold, or approximately -3 V . Thus, low dropout cannot be achieved when programming the output voltage more positive than approximately -3.3 V . A typical application circuit is shown in Figure 1.

UCC284-5, UCC284-12, UCC284-ADJ, UCC384-5, UCC384-12, UCC384-ADJ LOW-DROPOUT 0.5-A NEGATIVE LINEAR REGULATOR

SLUS234D – JANUARY 2000 – REVISED FEBRUARY 2002

APPLICATION INFORMATION

programming the output voltage on the UCC384 (continued)

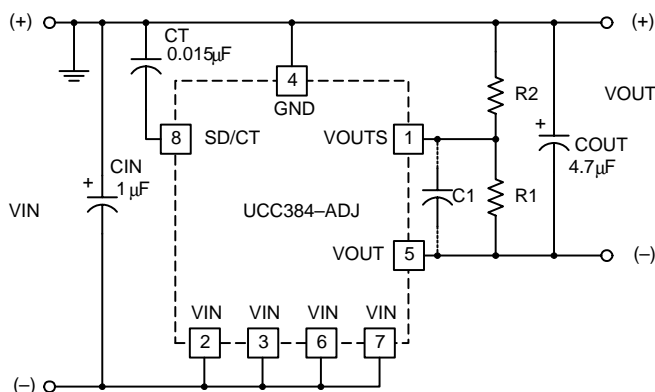

UDG-99029

Figure 1. Typical Application Circuit

For the UCC384-ADJ, the output voltage is programmed by the following equation:

$$V_{OUT} = -1.25 \times \left(1 + \frac{R_1}{R_2}\right) \quad (1)$$

When R1 or R2 are selected to be greater than about 100 kΩ, a small ceramic capacitor should be placed across R1 to cancel the input pole created by R1 and the parasitic capacitance appearing on VOUTS. Values of approximately 20 pF should be adequate.

dropout performance

The UCC384 is tailored for low-dropout applications where low-quiescent power is important. Fabricated with a BCDMOS technology ideally suited for low input-to-output differential applications, the UCC384 passes 0.5 A while requiring only 0.2 V of headroom. The dropout voltage is dependent on operating conditions such as load current, input and load voltages, and temperature. The UCC384 achieves a low $R_{DS(on)}$ through the use of an internal charge-pump that drives the MOSFET gate.

Figure 2 shows typical dropout voltages versus output voltage for the UCC384-5 V and -12 V versions as well as the UCC384-ADJ version programmed between -3.3 V and -15 V. Since the dropout voltage is also affected by output current, Figure 3 shows typical dropout voltages versus load current for different values of VOUT.

Operating temperatures also affect the $R_{DS(on)}$ and the dropout voltage of the UCC384. Figure 4 shows typical dropout voltages for the UCC384 over temperature under a full load of 0.5 A.

short-circuit protection

The UCC384 provides unique short-circuit protection circuitry that reduces power dissipation during a fault. When an overcurrent condition is detected, the device enters a pulsed mode of operation, limiting the output to a 2.5% duty cycle. This reduces the heat sink requirements during a fault. The operation of the UCC384 during an overcurrent condition is shown in Figure 5.

APPLICATION INFORMATION

short-circuit protection (continued)

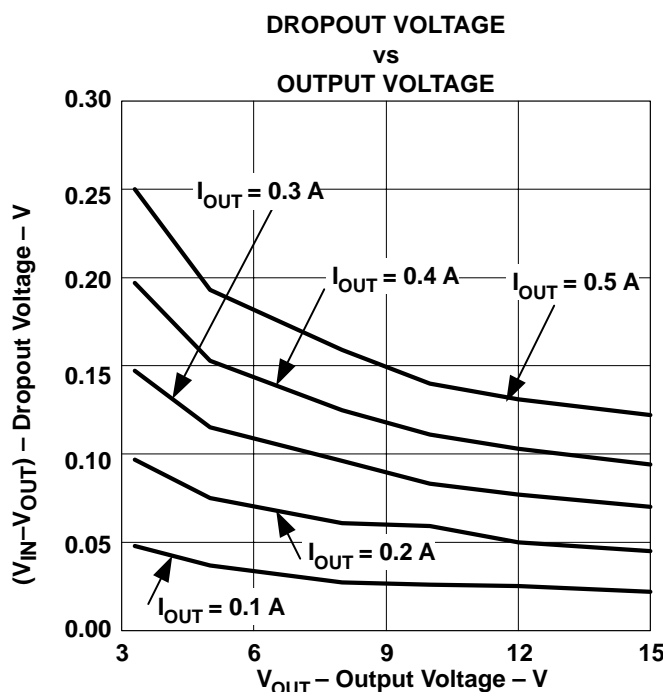

Figure 2

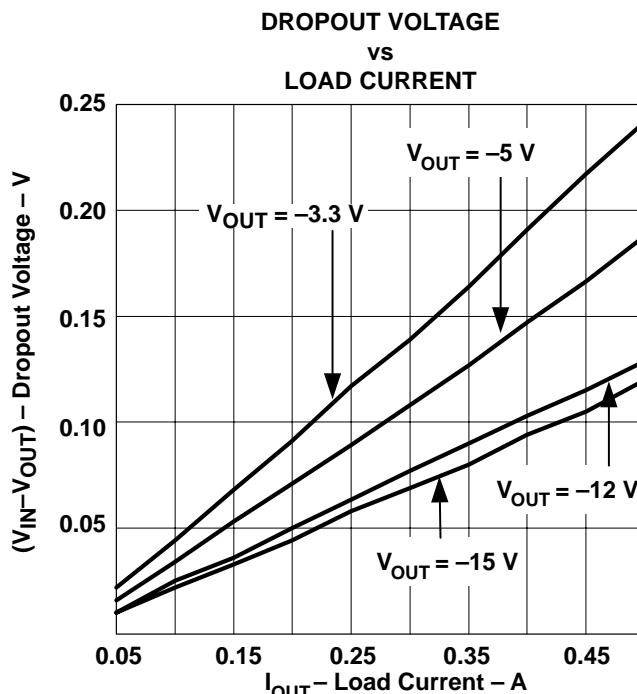

Figure 3

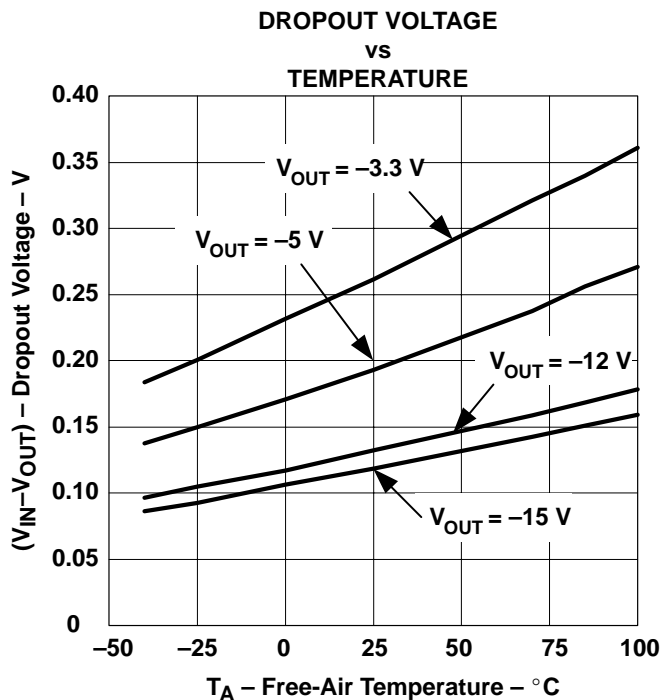

Figure 4

UCC284-5, UCC284-12, UCC284-ADJ, UCC384-5, UCC384-12, UCC384-ADJ LOW-DROPOUT 0.5-A NEGATIVE LINEAR REGULATOR

SLUS234D – JANUARY 2000 – REVISED FEBRUARY 2002

APPLICATION INFORMATION

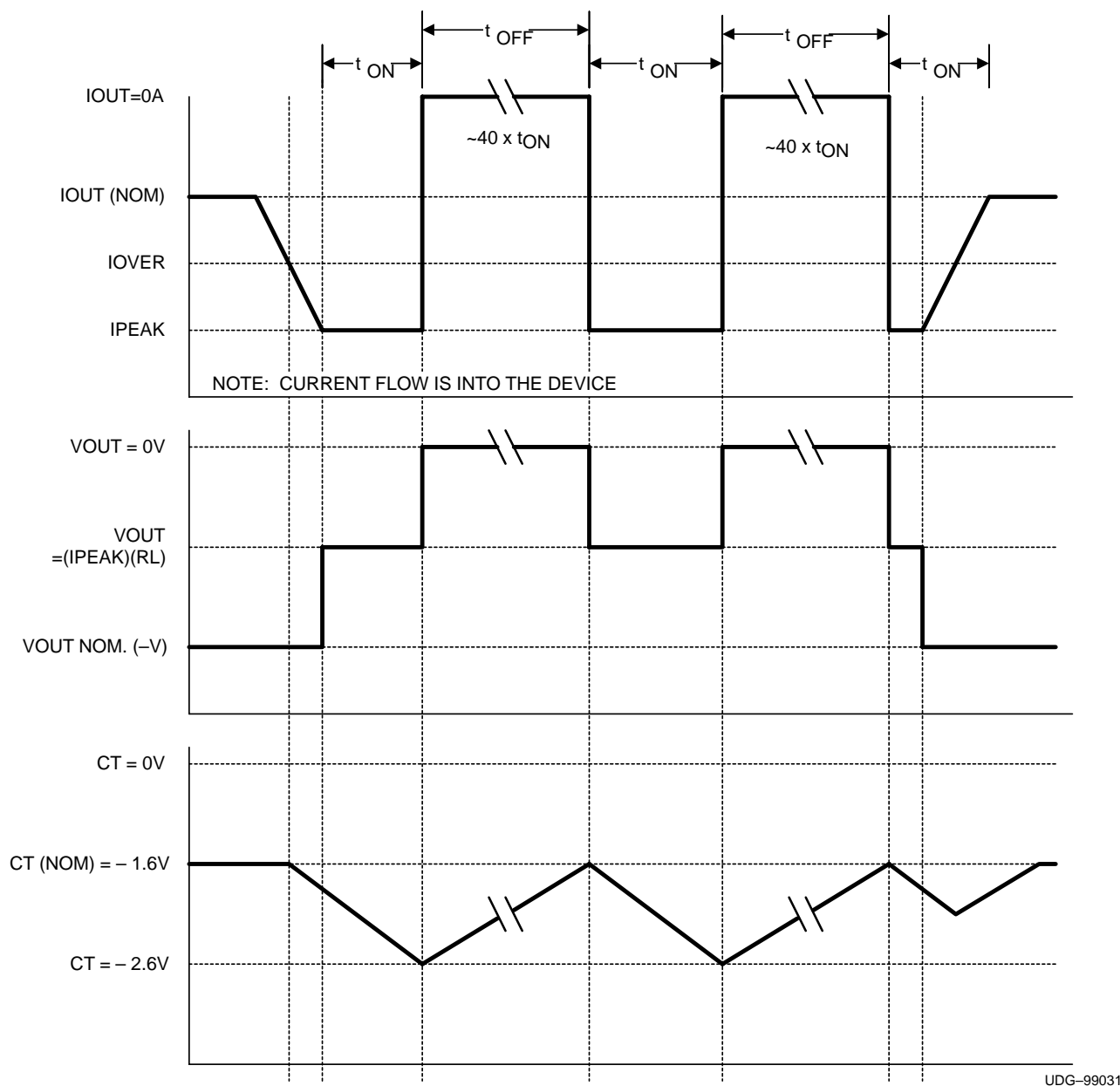

Figure 5. Short Circuit Timing

UCC384 short circuit timing

During normal operation the output voltage is in regulation and the SD/CT pin is held to $-1.5V$ via a $50-k\Omega$ internal-source impedance. If the output-current rises above the overcurrent threshold, the CT capacitor is charged by a $40-\mu A$ current sink. The voltage on the SD/CT pin moves in a negative direction with respect to GND.

APPLICATION INFORMATION

UCC384 short-circuit timing (continued)

During an overcurrent condition, the regulator actively limits the maximum output current to the peak-current limit. This limits the output voltage of the regulator to:

$$V_{OUT} = I_{PEAK} \times R_L \quad (1)$$

If the output current stays above the overcurrent threshold, the voltage on the SD/CT pin reaches –2.6 V with respect to GND and the output turns off. The CT capacitor is then discharged by a 1-μA current source. When the voltage on the SD/CT pin reaches –1.6 V with respect to GND, the output turns back on. This process repeats until the output current falls below the overcurrent threshold.

t_{ON} , the time the output is on during an overcurrent condition is determined by the following equation:

$$t_{ON} = CT (\mu F) \times \frac{1 V}{40 \mu A} \text{ seconds} \quad (2)$$

t_{OFF} , the time the output is off during an overcurrent condition is determined by the following equation:

$$t_{OFF} = CT (\mu F) \times \frac{1 V}{1 \mu A} \text{ seconds} \quad (3)$$

capacitive loads

A capacitive load on the regulator's output appears as a short-circuit during start-up. If the capacitance is too large, the output voltage does not begin to regulate during the initial t_{ON} period and the UCC384 enters a pulsed mode operation. For a constant current load the maximum allowed output capacitance is calculated as follows:

$$C_{OUT(max)} = [I_{PEAK(A)} - I_{LOAD(A)}] \times \frac{t_{ON(sec)}}{V_{OUT(V)}} \text{ Farads} \quad (4)$$

For worst case calculations, the minimum value for t_{ON} should be used, which is based on the value of CT capacitor selected. For a resistive load the maximum output capacitor can be estimated as follows:

$$C_{OUT(max)} = \frac{t_{ON(sec)}}{R_{LOAD} (\Omega) \times \ln \left[\frac{1}{1 - \left(\frac{V_{OUT} (V)}{I_{MAX(A)} \times R_{LOAD} (\Omega)} \right)} \right]} \text{ Farads} \quad (5)$$

Figure 6 and Figure 7 are oscilloscope photos of the UCC384-ADJ operating during an overcurrent condition. Figure 6 shows operation of the circuit as the output current initially rises above the overcurrent threshold. This is shown on a 1ms/div. scale. Figure 7 shows operation of the same circuit on a 25 ms/div. scale showing one complete cycle of operation during an overcurrent condition.

UCC284-5, UCC284-12, UCC284-ADJ, UCC384-5, UCC384-12, UCC384-ADJ LOW-DROPOUT 0.5-A NEGATIVE LINEAR REGULATOR

SLUS234D – JANUARY 2000 – REVISED FEBRUARY 2002

APPLICATION INFORMATION

**UCC384-ADJ
OVERCURRENT CONDITION OPERATION
1 ms/div**

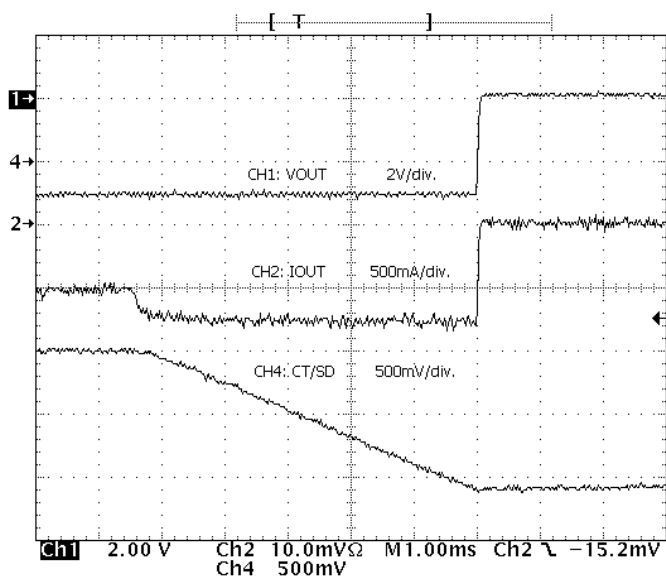

Figure 6

**UCC384-ADJ
OVERCURRENT CONDITION OPERATION
25 ms/div**

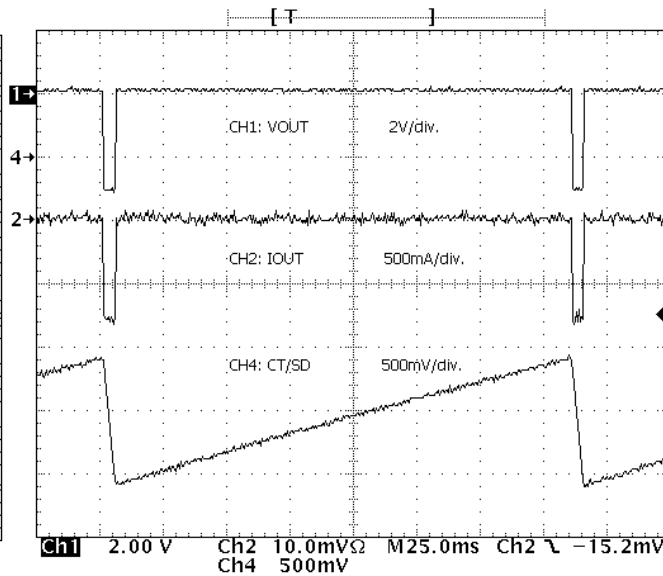
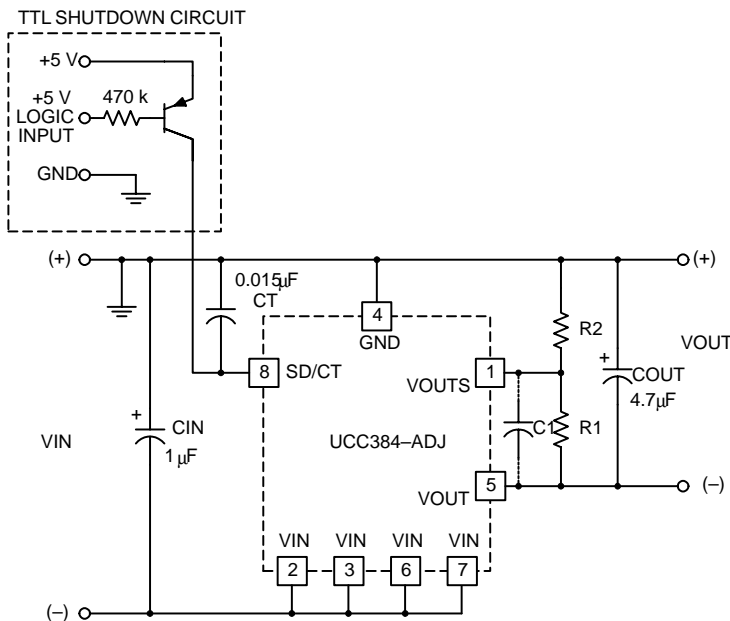

Figure 7

shutdown feature of the UCC384

The shutdown feature of the UCC384 allows the device to be placed in a low quiescent current mode. The UCC384 is shut down by pulling the SD/CT pin more positive than -0.7 V with respect to GND. Figure 8 shows how a shutdown circuit can be configured for the UCC384 using a standard transistor-transistor logic signal to control it.



UDG-99032

Figure 8. TTL Controlled Shutdown Circuit for the UCC384



APPLICATION INFORMATION

controlling the SD/CT pin

Forcing the SD/CT pin to any fixed voltage affects the operation of the circuit. As mentioned before, pulling the SD/CT pin more positive than -0.7 V puts the circuit in a shutdown mode, limiting the quiescent current to less than $45\text{ }\mu\text{A}$. Pulling this pin more positive than 6 V with respect to GND damages the device.

Forcing the SD/CT pin to any fixed voltage between -0.7 V and -1.6 V with respect to GND enables the output. However, in an overcurrent condition, the output does not pulse at a 2.5% duty cycle, but the output current is still limited to the peak current limit. This circuit may be used where a fixed current limit is needed, where a 2.5% duty cycle is undesirable. The UCC384 supplies a maximum current in this configuration as long as the temperature of the device does not exceed the overtemperature shutdown. This is determined by the peak current being supplied, the input and output voltages, and the type of heat sink being used. *Thermal design* is discussed later on in this data sheet.

Forcing the SD/CT pin to a voltage level between approximately -1.6 V and -2.6 V with respect to GND is not recommended as the output may or may not be enabled.

Forcing the SD/CT pin to a voltage level between approximately -2.6 V and -5 V with respect to GND turns the output off completely. The output remains off as long as the voltage is applied. Pulling this pin more negative than -5 V with respect to GND damages the device (see Table 1).

Table 1 SD/CT Voltage Levels

SD/CT	STATE
6 V to -0.7 V	Output disabled and device in low quiescent shutdown mode.
-0.7 V to -1.6 V	Output enabled
-1.6 V to -2.6 V	Output enabled or disabled depending on the previous state.
-2.6 V to -5 V	Output disabled

**VIN TO VOUT DELAY TIME
DURING POWER-UP WITH CT = 0.22 μF**

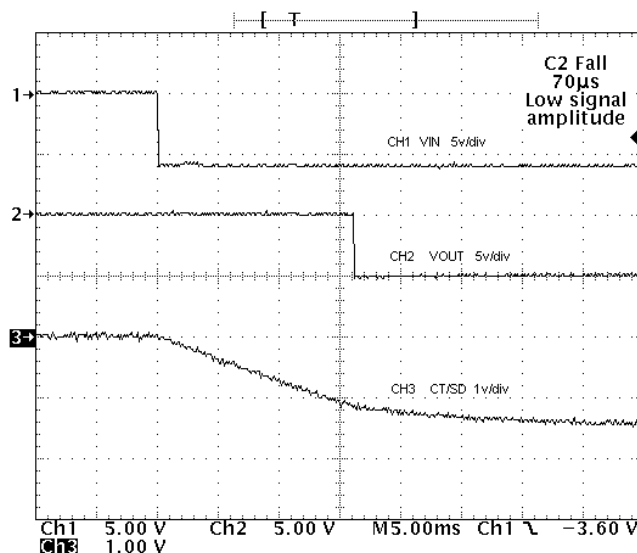

Figure 9

UCC284-5, UCC284-12, UCC284-ADJ, UCC384-5, UCC384-12, UCC384-ADJ LOW-DROPOUT 0.5-A NEGATIVE LINEAR REGULATOR

SLUS234D – JANUARY 2000 – REVISED FEBRUARY 2002

APPLICATION INFORMATION

VIN to VOUT Delay

During power-up there is a delay between VIN and VOUT. The majority of this delay time is due to the charging time of the CT capacitor. When VIN moves more negative than the UVLO of the device with respect to GND, the CT capacitor begins to charge. A 17- μ A current sink is used only during power up to charge the CT capacitor. When the voltage on the SD/CT pin reaches approximately -1.6 V with respect to GND, the output turns on and regulates. The larger the value of the CT capacitor, the greater the delay time between VIN and VOUT. Figure 9 shows the VIN to VOUT start-up delay, approximately 16 ms for a circuit with CT = 0.22 μ F.

Shorter delay times can be achieved with a smaller CT capacitor. The problem with a smaller CT capacitor is that with a very large load, the circuit may stay in overcurrent mode and never turn on. A circuit with a large capacitive load needs a large CT capacitor to operate properly.

One way to shorten the delay from VIN to VOUT during powerup, is with the use of the quick start-up circuit shown in Figure 10.

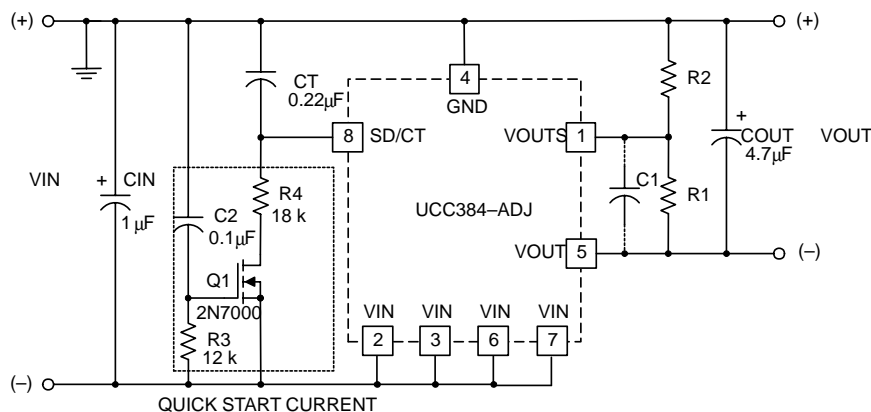

UDG-99033

Figure 10. Quick Start-Up Circuit for UCC384

With the quick start-up circuit, the delay time between VIN and VOUT during start-up can be reduced dramatically. Figure 11 shows that with the quick start-up circuit, the VIN to VOUT delay time has been reduced to approximately 1 ms.

APPLICATION INFORMATION

VIN to VOUT Delay

**VIN TO VOUT DELAY TIME
WITH QUICK START-UP CIRCUIT**

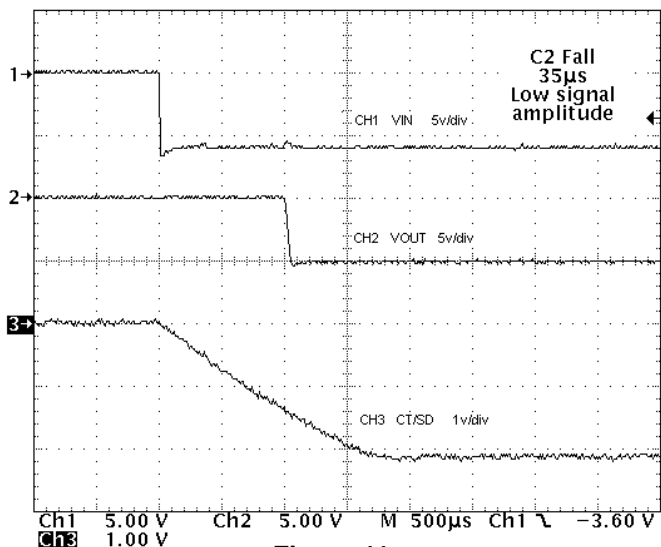

Figure 11

**VIN TO VOUT DELAY TIME
WITH CT CAPACITOR REMOVED**

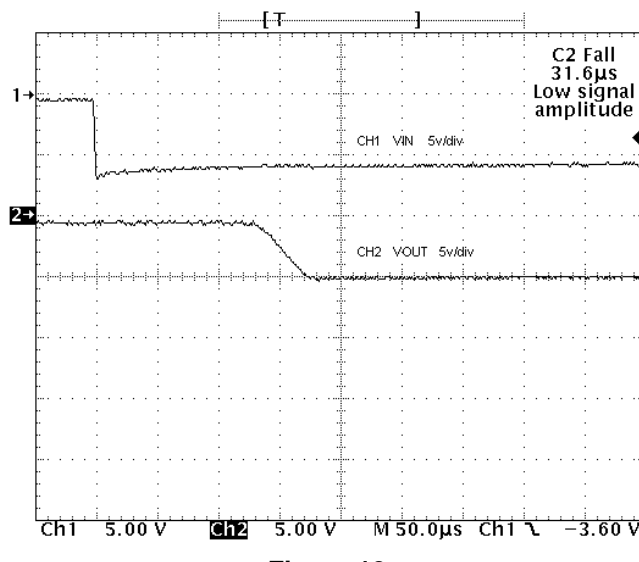

Figure 12

operation of the quick start-up circuit

During normal start-up, the UCC384 does not turn on until the voltage on the SD/CT pin reaches approximately -1.6 V with respect to ground. It takes a certain amount of time for the CT capacitor to charge to this point. For a circuit that has a very large load, the CT capacitor needs to be large in order for the overcurrent timing to work properly. A large value of capacitance on the SD/CT pin increases the VIN to VOUT delay time.

The quick start-up circuit uses Q1 to quickly pull the SD/CT pin in a negative direction during start-up, thus decreasing the VIN-to-VOUT delay time. When VIN is applied to the circuit, Q1 turns on and starts to charge the CT capacitor. The current pulled through R4 determines the rate at which CT is charged. R4 can be calculated as follows:

$$R4 = \frac{V_{IN}(V) \times T_D \text{ seconds}}{1.6 \times CT (F)} \text{ ohms} \quad (6)$$

t_D is the approximate VIN-to-VOUT delay time desired.

Q1 needs to be turned off after a fixed time to prevent the SD/CT pin from going too far negative with respect to GND. If the SD/CT pin is allowed to go too far negative with respect to GND, the output turns off again or possibly even damages the SD/CT pin. The maximum amount of time that Q1 should be allowed to be on is referred to as t_M and can be calculated as follows:

$$t_M = \frac{2.6}{1.6} \times t_D \text{ seconds} \quad (7)$$

R3 along with C2 set the time that Q1 is allowed to be on. Since t_M is the maximum amount of time that Q1 should be allowed to stay on, an added safety margin may be to use $0.9 \times t_M$ instead. This ensures that Q1 is turned off in the proper amount of time. With a chosen value for C2, R3 can be calculated as follows:

UCC284-5, UCC284-12, UCC284-ADJ, UCC384-5, UCC384-12, UCC384-ADJ LOW-DROPOUT 0.5-A NEGATIVE LINEAR REGULATOR

SLUS234D – JANUARY 2000 – REVISED FEBRUARY 2002

APPLICATION INFORMATION

operation of the quick start-up circuit (continued)

$$R3 = \frac{0.9 \times t_M \text{ seconds}}{C2(F) \times \ln \left(1 - \frac{V_{IN}(V) - 1.6}{V_{IN}(V)} \right)} \text{ Ohms} \quad (8)$$

After the CT capacitor has charged up for a time equal to $0.9 \times t_M$, Q1 turns off and allows the SD/CT pin to be pulled back to -1.5 V with respect to GND through a $50\text{-k}\Omega$ resistor. At this point, the SD/CT pin can be used by the UCC384 overcurrent timing control.

minimum V_{IN} to V_{OUT} delay time

Although it may be desirable to have as short a delay time as possible, a small portion of this delay time is fixed by the UCC384 and cannot be shortened. This is shown in Figure 12, where the CT capacitor has been removed from the circuit completely, giving a fixed V_{IN} to V_{OUT} delay of approximately $150\ \mu\text{s}$ for a circuit with $V_{IN} = -6$ V and $V_{OUT} = -5$ V.

thermal design

The *Packaging Information* section of the *Power Supply Control Products Data Book* (TI Literature No. SLUD003) contains reference material for the thermal ratings of various packages. The section also includes an excellent article entitled *Thermal Characteristics of Surface Mount Packages*, which is the basis for the following discussion.

Thermal design for the UCC384 includes two modes of operation, normal and pulsed. In normal mode, the linear regulator and heat sink must dissipate power equal to the maximum forward voltage drop multiplied by the maximum load current. Assuming a constant current load, the expected heat rise at the regulator's junction can be calculated as follows:

$$t_{RISE} = P_{DISS} \times (\theta_{jc} + \theta_{ca}) \quad (9)$$

Theta (θ) is the thermal resistance and P_{DISS} is the power dissipated. The junction-to-case thermal resistance (θ_{jc}) of the SOIC-8 DP package is 22°C/W . In order to prevent the regulator from going into thermal shutdown, the case-to-ambient thermal resistance (θ_{ca}) must keep the junction temperature below 150°C . If the UCC384 is mounted on a 5 square inch pad of 1-ounce copper, for example, the thermal resistance (θ_{ja}) becomes $40\text{--}70^\circ\text{C/W}$. If a lower thermal resistance is required for the application, the device heat sinking needs to be improved.

When the UCC384 is in a pulsed mode, due to an overcurrent condition, the maximum average power dissipation is calculated as follows:

$$P_{avg} = [V_{IN}(V) - V_{OUT}(V)] \times I_{PEAK}(A) \times \left(\frac{t_{ON}(\text{seconds})}{40 \times t_{ON}(\text{seconds})} \right) \text{ Watts} \quad (10)$$

As seen in equation (10), the average power during a fault is reduced dramatically by the duty cycle, allowing the heat sink to be sized for normal operation. Although the peak power in the regulator during the t_{ON} period can be significant, the thermal mass of the package normally keeps the junction temperature from rising unless the t_{ON} period is increased to several milliseconds.

PACKAGING INFORMATION

Orderable Device	Status ⁽¹⁾	Package Type	Package Drawing	Pins	Package Qty	Eco Plan ⁽²⁾	Lead/Ball Finish	MSL Peak Temp ⁽³⁾
UCC284DP-12	ACTIVE	SOIC	D	8	75	Green (RoHS & no Sb/Br)	CU NIPDAU	Level-2-260C-1 YEAR
UCC284DP-12G4	ACTIVE	SOIC	D	8	75	Green (RoHS & no Sb/Br)	CU NIPDAU	Level-2-260C-1 YEAR
UCC284DP-5	ACTIVE	SOIC	D	8	75	Green (RoHS & no Sb/Br)	CU NIPDAU	Level-2-260C-1 YEAR
UCC284DP-5G4	ACTIVE	SOIC	D	8	75	Green (RoHS & no Sb/Br)	CU NIPDAU	Level-2-260C-1 YEAR
UCC284DP-ADJ	ACTIVE	SOIC	D	8	75	Green (RoHS & no Sb/Br)	CU NIPDAU	Level-2-260C-1 YEAR
UCC284DP-ADJG4	ACTIVE	SOIC	D	8	75	Green (RoHS & no Sb/Br)	CU NIPDAU	Level-2-260C-1 YEAR
UCC284DPTR-5	ACTIVE	SOIC	D	8	2500	Green (RoHS & no Sb/Br)	CU NIPDAU	Level-2-260C-1 YEAR
UCC284DPTR-5G4	ACTIVE	SOIC	D	8	2500	Green (RoHS & no Sb/Br)	CU NIPDAU	Level-2-260C-1 YEAR
UCC284DPTR-ADJ	ACTIVE	SOIC	D	8	2500	Green (RoHS & no Sb/Br)	CU NIPDAU	Level-2-260C-1 YEAR
UCC284DPTR-ADJG4	ACTIVE	SOIC	D	8	2500	Green (RoHS & no Sb/Br)	CU NIPDAU	Level-2-260C-1 YEAR
UCC384DP-12	ACTIVE	SOIC	D	8	75	Green (RoHS & no Sb/Br)	CU NIPDAU	Level-2-260C-1 YEAR
UCC384DP-12G4	ACTIVE	SOIC	D	8	75	Green (RoHS & no Sb/Br)	CU NIPDAU	Level-2-260C-1 YEAR
UCC384DP-5	ACTIVE	SOIC	D	8	75	Green (RoHS & no Sb/Br)	CU NIPDAU	Level-2-260C-1 YEAR
UCC384DP-5G4	ACTIVE	SOIC	D	8	75	Green (RoHS & no Sb/Br)	CU NIPDAU	Level-2-260C-1 YEAR
UCC384DP-ADJ	ACTIVE	SOIC	D	8	75	Green (RoHS & no Sb/Br)	CU NIPDAU	Level-2-260C-1 YEAR
UCC384DP-ADJG4	ACTIVE	SOIC	D	8	75	Green (RoHS & no Sb/Br)	CU NIPDAU	Level-2-260C-1 YEAR
UCC384DPTR-12	ACTIVE	SOIC	D	8	2500	Green (RoHS & no Sb/Br)	CU NIPDAU	Level-2-260C-1 YEAR
UCC384DPTR-12G4	ACTIVE	SOIC	D	8	2500	Green (RoHS & no Sb/Br)	CU NIPDAU	Level-2-260C-1 YEAR
UCC384DPTR-5	ACTIVE	SOIC	D	8	2500	Green (RoHS & no Sb/Br)	CU NIPDAU	Level-2-260C-1 YEAR
UCC384DPTR-5G4	ACTIVE	SOIC	D	8	2500	Green (RoHS & no Sb/Br)	CU NIPDAU	Level-2-260C-1 YEAR
UCC384DPTR-ADJ	ACTIVE	SOIC	D	8	2500	Green (RoHS & no Sb/Br)	CU NIPDAU	Level-2-260C-1 YEAR
UCC384DPTR-ADJG4	ACTIVE	SOIC	D	8	2500	Green (RoHS & no Sb/Br)	CU NIPDAU	Level-2-260C-1 YEAR

⁽¹⁾ The marketing status values are defined as follows:

ACTIVE: Product device recommended for new designs.

LIFEBUY: TI has announced that the device will be discontinued, and a lifetime-buy period is in effect.

NRND: Not recommended for new designs. Device is in production to support existing customers, but TI does not recommend using this part in a new design.

PREVIEW: Device has been announced but is not in production. Samples may or may not be available.

OBSOLETE: TI has discontinued the production of the device.

⁽²⁾ Eco Plan - The planned eco-friendly classification: Pb-Free (RoHS), Pb-Free (RoHS Exempt), or Green (RoHS & no Sb/Br) - please check <http://www.ti.com/productcontent> for the latest availability information and additional product content details.

TBD: The Pb-Free/Green conversion plan has not been defined.

Pb-Free (RoHS): TI's terms "Lead-Free" or "Pb-Free" mean semiconductor products that are compatible with the current RoHS requirements for all 6 substances, including the requirement that lead not exceed 0.1% by weight in homogeneous materials. Where designed to be soldered at high temperatures, TI Pb-Free products are suitable for use in specified lead-free processes.

Pb-Free (RoHS Exempt): This component has a RoHS exemption for either 1) lead-based flip-chip solder bumps used between the die and package, or 2) lead-based die adhesive used between the die and leadframe. The component is otherwise considered Pb-Free (RoHS compatible) as defined above.

Green (RoHS & no Sb/Br): TI defines "Green" to mean Pb-Free (RoHS compatible), and free of Bromine (Br) and Antimony (Sb) based flame retardants (Br or Sb do not exceed 0.1% by weight in homogeneous material)

⁽³⁾ MSL, Peak Temp. -- The Moisture Sensitivity Level rating according to the JEDEC industry standard classifications, and peak solder temperature.

Important Information and Disclaimer:The information provided on this page represents TI's knowledge and belief as of the date that it is provided. TI bases its knowledge and belief on information provided by third parties, and makes no representation or warranty as to the accuracy of such information. Efforts are underway to better integrate information from third parties. TI has taken and continues to take reasonable steps to provide representative and accurate information but may not have conducted destructive testing or chemical analysis on incoming materials and chemicals. TI and TI suppliers consider certain information to be proprietary, and thus CAS numbers and other limited information may not be available for release.

In no event shall TI's liability arising out of such information exceed the total purchase price of the TI part(s) at issue in this document sold by TI to Customer on an annual basis.

TAPE AND REEL INFORMATION

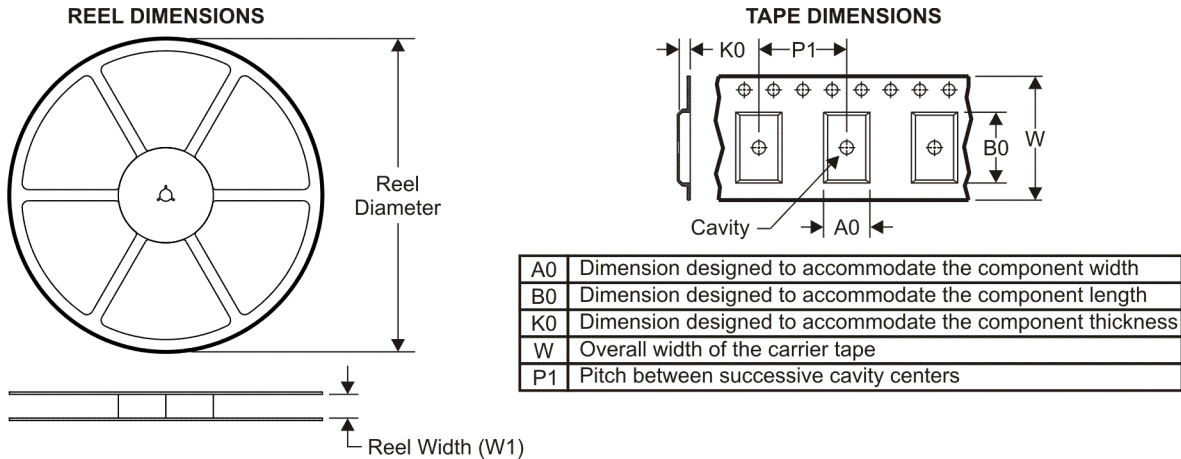

QUADRANT ASSIGNMENTS FOR PIN 1 ORIENTATION IN TAPE

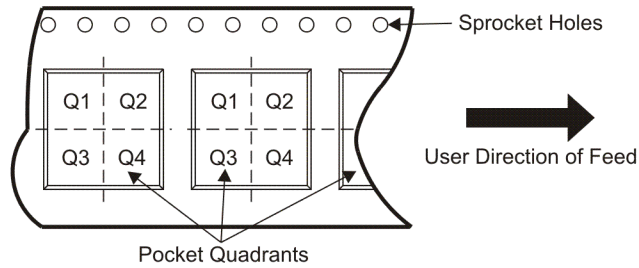

*All dimensions are nominal

Device	Package Type	Package Drawing	Pins	SPQ	Reel Diameter (mm)	Reel Width W1 (mm)	A0 (mm)	B0 (mm)	K0 (mm)	P1 (mm)	W (mm)	Pin1 Quadrant
UCC284DPTR-5	SOIC	D	8	2500	330.0	12.4	6.4	5.2	2.1	8.0	12.0	Q1
UCC284DPTR-ADJ	SOIC	D	8	2500	330.0	12.4	6.4	5.2	2.1	8.0	12.0	Q1
UCC384DPTR-12	SOIC	D	8	2500	330.0	12.4	6.4	5.2	2.1	8.0	12.0	Q1
UCC384DPTR-5	SOIC	D	8	2500	330.0	12.4	6.4	5.2	2.1	8.0	12.0	Q1
UCC384DPTR-ADJ	SOIC	D	8	2500	330.0	12.4	6.4	5.2	2.1	8.0	12.0	Q1

TAPE AND REEL BOX DIMENSIONS

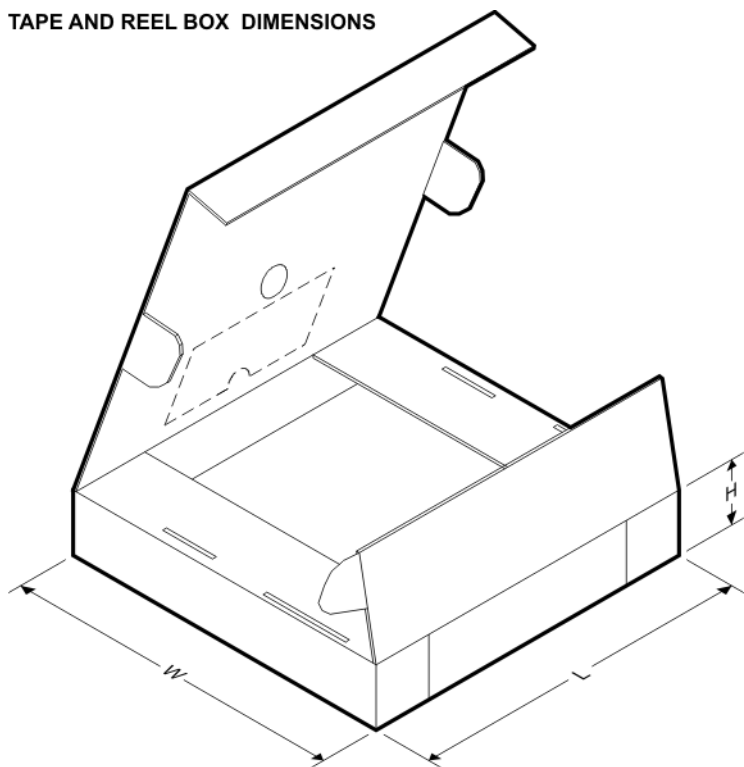

*All dimensions are nominal

Device	Package Type	Package Drawing	Pins	SPQ	Length (mm)	Width (mm)	Height (mm)
UCC284DPTR-5	SOIC	D	8	2500	346.0	346.0	29.0
UCC284DPTR-ADJ	SOIC	D	8	2500	346.0	346.0	29.0
UCC384DPTR-12	SOIC	D	8	2500	346.0	346.0	29.0
UCC384DPTR-5	SOIC	D	8	2500	346.0	346.0	29.0
UCC384DPTR-ADJ	SOIC	D	8	2500	346.0	346.0	29.0

IMPORTANT NOTICE

Texas Instruments Incorporated and its subsidiaries (TI) reserve the right to make corrections, modifications, enhancements, improvements, and other changes to its products and services at any time and to discontinue any product or service without notice. Customers should obtain the latest relevant information before placing orders and should verify that such information is current and complete. All products are sold subject to TI's terms and conditions of sale supplied at the time of order acknowledgment.

TI warrants performance of its hardware products to the specifications applicable at the time of sale in accordance with TI's standard warranty. Testing and other quality control techniques are used to the extent TI deems necessary to support this warranty. Except where mandated by government requirements, testing of all parameters of each product is not necessarily performed.

TI assumes no liability for applications assistance or customer product design. Customers are responsible for their products and applications using TI components. To minimize the risks associated with customer products and applications, customers should provide adequate design and operating safeguards.

TI does not warrant or represent that any license, either express or implied, is granted under any TI patent right, copyright, mask work right, or other TI intellectual property right relating to any combination, machine, or process in which TI products or services are used. Information published by TI regarding third-party products or services does not constitute a license from TI to use such products or services or a warranty or endorsement thereof. Use of such information may require a license from a third party under the patents or other intellectual property of the third party, or a license from TI under the patents or other intellectual property of TI.

Reproduction of TI information in TI data books or data sheets is permissible only if reproduction is without alteration and is accompanied by all associated warranties, conditions, limitations, and notices. Reproduction of this information with alteration is an unfair and deceptive business practice. TI is not responsible or liable for such altered documentation. Information of third parties may be subject to additional restrictions.

Resale of TI products or services with statements different from or beyond the parameters stated by TI for that product or service voids all express and any implied warranties for the associated TI product or service and is an unfair and deceptive business practice. TI is not responsible or liable for any such statements.

TI products are not authorized for use in safety-critical applications (such as life support) where a failure of the TI product would reasonably be expected to cause severe personal injury or death, unless officers of the parties have executed an agreement specifically governing such use. Buyers represent that they have all necessary expertise in the safety and regulatory ramifications of their applications, and acknowledge and agree that they are solely responsible for all legal, regulatory and safety-related requirements concerning their products and any use of TI products in such safety-critical applications, notwithstanding any applications-related information or support that may be provided by TI. Further, Buyers must fully indemnify TI and its representatives against any damages arising out of the use of TI products in such safety-critical applications.

TI products are neither designed nor intended for use in military/aerospace applications or environments unless the TI products are specifically designated by TI as military-grade or "enhanced plastic." Only products designated by TI as military-grade meet military specifications. Buyers acknowledge and agree that any such use of TI products which TI has not designated as military-grade is solely at the Buyer's risk, and that they are solely responsible for compliance with all legal and regulatory requirements in connection with such use.

TI products are neither designed nor intended for use in automotive applications or environments unless the specific TI products are designated by TI as compliant with ISO/TS 16949 requirements. Buyers acknowledge and agree that, if they use any non-designated products in automotive applications, TI will not be responsible for any failure to meet such requirements.

Following are URLs where you can obtain information on other Texas Instruments products and application solutions:

Products

Amplifiers	amplifier.ti.com
Data Converters	dataconverter.ti.com
DSP	dsp.ti.com
Clocks and Timers	www.ti.com/clocks
Interface	interface.ti.com
Logic	logic.ti.com
Power Mgmt	power.ti.com
Microcontrollers	microcontroller.ti.com
RFID	www.ti-rfid.com
RF/IF and ZigBee® Solutions	www.ti.com/lprf

Applications

Audio	www.ti.com/audio
Automotive	www.ti.com/automotive
Broadband	www.ti.com/broadband
Digital Control	www.ti.com/digitalcontrol
Medical	www.ti.com/medical
Military	www.ti.com/military
Optical Networking	www.ti.com/opticalnetwork
Security	www.ti.com/security
Telephony	www.ti.com/telephony
Video & Imaging	www.ti.com/video
Wireless	www.ti.com/wireless

Mailing Address: Texas Instruments, Post Office Box 655303, Dallas, Texas 75265
Copyright © 2008, Texas Instruments Incorporated

Looking for pricing, stock, or lifecycle information?

Click below to explore more details on WIN SOURCE:

 [View UCC284DPTR-ADJ on WIN SOURCE](#)

 [Texas Instruments](#) Information

Optimize Your Supply Chain with WIN SOURCE Solutions

-  Global Sourcing Solution
-  Obsolete Management
-  Cost Control Management
-  Shortage Management
-  Alternative Solution
-  Excess Inventory Management