



**THE DATASHEET OF  
A4402KLPTR-T**



## Constant On-Time Buck Converter With Integrated Linear Regulator

### FEATURES AND BENEFITS

- 2 MHz switching frequency
- Adjustable soft start timer
- Watchdog input
- Power-on reset output
- Adjustable buck and linear regulators
- Enable input
- 6 to 50 V supply voltage range
- Overcurrent protection
- Undervoltage lockout (UVLO)
- Thermal shutdown protection

### APPLICATIONS:

#### AUTOMOTIVE (“K” VERSION)

- Power steering control units
- Transmission control units
- Lighting control units
- Infotainment
- Cluster
- Centerstack
- Other body control

#### COMMERCIAL (“E” VERSION)

- Photo and inkjet printers
- Industrial controls
- Distributed power systems
- Networking applications
- Point-of-sale
- Security systems

### PACKAGE:

16-pin eTSSOP with exposed thermal pad (suffix LP)

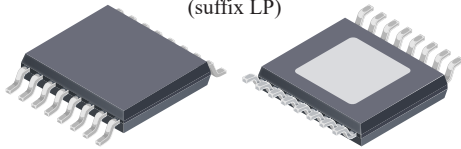

Not to scale

### DESCRIPTION

The A4402 is a dual-output regulator, combining in a single package a constant on-time buck regulator and a linear regulator (LDO)—each with adjustable output voltages. It is ideal for applications that require two regulated voltages, such as in microcontroller- or DSP-based applications requiring core and I/O voltage rails.

The buck regulator output supplies the adjustable linear regulator to reduce power dissipation and increase overall efficiency. The switching regulator is capable of operating above 2 MHz, allowing the use of small low value inductors and capacitors while avoiding sensitive EMI frequency bands such as AM radio in automotive applications.

Protection features include undervoltage lockout and thermal shutdown. In case of a shorted load, each regulator features overcurrent protection.

The device has an integrated power-on reset with adjustable delay to monitor LDO output voltage and provide a signal that can be used to reset a DSP or microcontroller. It also includes a watchdog circuit.

The A4402 is provided in a 16-pin eTSSOP, with exposed pad for enhanced thermal dissipation. It is lead (Pb) free, with 100% matte tin leadframe plating.

### Typical Application

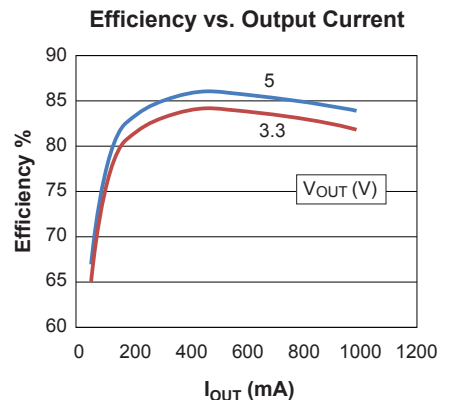
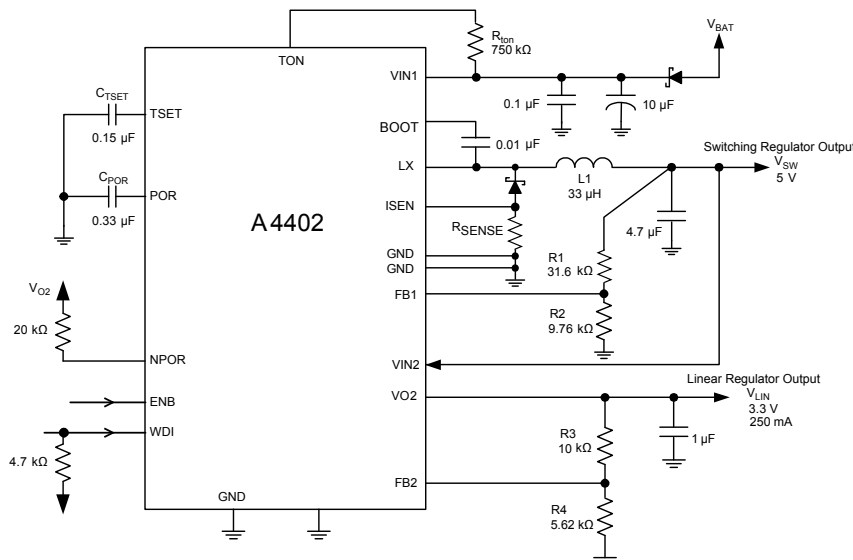

Data is for reference only. Efficiency data from circuit shown in left panel.

### SELECTION GUIDE

Part Number	Ambient Operating Temperature, $T_A$	Packing	Package
A4402ELPTR-T	-40°C to 85°C	4000 pieces per 13-inch reel	16-pin eTSSOP with exposed thermal pad
A4402KLPTR-T	-40°C to 150°C		

### ABSOLUTE MAXIMUM RATINGS

Characteristic	Symbol	Notes	Rating	Unit
VIN1 Pin	$V_{IN1}$		-0.3 to 50	V
VIN2 Pin	$V_{IN2}$		-0.3 to 7	V
LX Pin	$V_{LX}$		-1 to 50	V
ISEN Pin	$V_{ISEN}$		-0.5 to 1	V
ENB Pin	$V_{ENB}$		-0.3 to 7	V
VO2 Pin	$V_{O2}$		-0.3 to 7	V
WDI Pin	$V_{WDI}$		-0.3 to 6	V
TON Pin	$V_{TON}$		-0.3 to 7	V
FB1 and FB2 Pins	$V_{FBx}$		-0.3 to 7	V
NPOR	$V_{NPOR}$		-0.3 to 6.5	V
TSET Pin	$V_{TSET}$		-0.3 to 7	V
POR Pin	$V_{POR}$		-0.3 to 6	V
BOOT Pin	$V_{BOOT}$		$V_{LX}$ to $V_{IN1}+7$	V
Ambient Operating Temperature	$T_A$	Range E	-40 to 85	°C
		Range K	-40 to 150	°C
Junction Temperature	$T_{J(max)}$		150	°C
Storage Temperature Range	$T_{stg}$		-40 to 150	°C

### THERMAL CHARACTERISTICS

Characteristic	Symbol	Test Conditions*	Value	Unit
Package Thermal Resistance	$R_{\theta JA}$	On 4-layer PCB based on JEDEC standard JESD51-7	34	°C/W

\*Additional thermal information available on the Allegro website.

### FUNCTIONAL BLOCK DIAGRAM

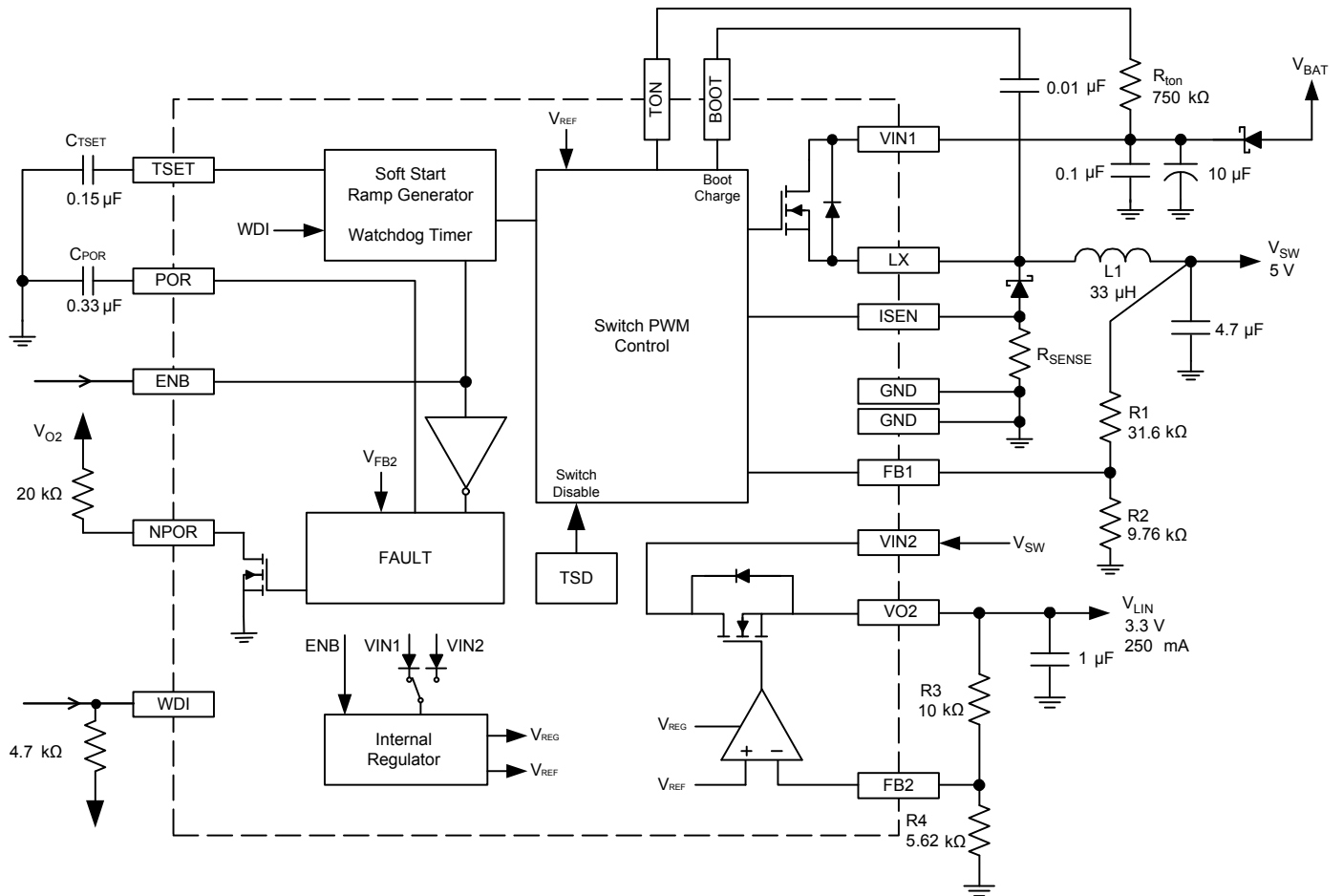

### PINOUT DIAGRAM AND TERMINAL LIST

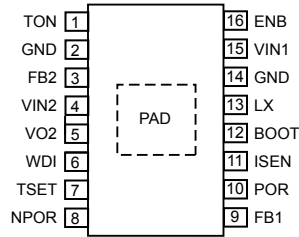

**LP-16 PINOUT DIAGRAM**

### TERMINAL LIST TABLE

Number	Name	Function
1	TON	On time setting terminal
2	GND	Ground
3	FB2	Feedback for $V_{LIN}$
4	VIN2	Input voltage 2
5	VO2	Regulator 2 output
6	WDI	Watchdog input
7	TSET	Soft start and watchdog timing capacitor terminal
8	NPOR	Fault output
9	FB1	Feedback for $V_{SW}$
10	POR	POR delay
11	ISEN	Current sense, limit setting for switching regulator, connect to GND through series resistor
12	BOOT	Boot node for LX
13	LX	Switching regulator output
14	GND	Ground
15	VIN1	Input voltage 1
16	ENB	Enable input
–	PAD	Exposed thermal pad

**ELECTRICAL CHARACTERISTICS<sup>[1]</sup>: Valid for Temperature Range E version at  $T_J = 25^\circ\text{C}$  and for Temperature Range K version at  $T_J = -40^\circ\text{C}$  to  $150^\circ\text{C}$ ,  $V_{IN1} = 6$  to  $50$  V (unless otherwise noted)**

Characteristics	Symbol	Test Conditions	Min.	Typ.	Max.	Unit
Supply Quiescent Current	$I_{IN(Q)}$	$V_{ENB} = 5$ V, $I_{OUT} = I_{SW} + I_{LIN} = 0$ mA, $13.5$ V < $V_{IN1} < 50$ V	1	–	6	mA
		$V_{ENB} = 0$ V, $13.5$ V < $V_{IN1} < 18$ V, $I_{OUT} = I_{SW} + I_{LIN} = 0$ mA	–	–	1	$\mu$ A
ENB Logic Input Voltage	$V_{ENB}$	$V_{ENB}$ rising	2.0	2.28	2.56	V
ENB Hysteresis	$V_{ENBHYS}$		–	100	–	mV
ENB Logic Input Current <sup>[2]</sup>	$I_{ENB}$	High input level, $V_{ENB} = 3$ V	–	–	100	$\mu$ A
		Low input level, $V_{ENB} < 0.4$ V	–2	–	2	$\mu$ A
<b>LINEAR REGULATOR</b>						
Feedback Voltage	$V_{FB2}$	$1$ mA < $I_{O2} < 250$ mA, $3.3$ V < $V_{IN2} < 5$ V	1.156	1.180	1.204	V
$V_{O2}$ Undervoltage Lockout Threshold	$V_{O2UVLO}$	$V_{O2}$ rising based on FB voltage	0.896	0.944	0.990	V
$V_{O2}$ Undervoltage Lockout Hysteresis	$V_{O2UVHYS}$		30	50	70	mV
Feedback Input Bias Current <sup>[2]</sup>	$I_{FB2}$		–100	100	400	nA
Current Limit	$I_{O2}$		250	–	350	mA
<b>SWITCHING REGULATOR</b>						
Feedback Voltage	$V_{FB1}$	$I_{OUT} = I_{SW} + I_{LIN} = 1$ mA to 1.0 A, $8$ V < $V_{IN1} < 18$ V	1.139	1.180	1.221	V
Feedback Input Bias Current	$I_{FB1}$	$V_{IN1} = 6$ V	–400	–100	100	nA
Switcher On Time	$t_{on}$	$V_{IN1} = 19.25$ V, $R_{ton} = 750$ k $\Omega$	450	640	830	ns
		$V_{IN1} = 13.5$ V, $R_{ton} = 750$ k $\Omega$	165	230	300	ns
		$V_{IN1} = 8$ V, $R_{ton} = 750$ k $\Omega$	1050	1480	1925	ns
$t_{on}$ Low Voltage Threshold	$V_{PL}$	$V_{IN1}$ rising	8.1	9	9.9	V
$t_{on}$ High Voltage Threshold	$V_{PH}$	$V_{IN1}$ rising	15.75	17.5	19.25	V
Changeover Hysteresis	$V_{HYS}$		–	250	–	mV
Minimum On-Time	$t_{onmin}$		80	–	–	ns
Minimum Off-Time	$t_{offmin}$		130	–	–	ns
Buck Switch On-Resistance	$R_{DS(on)}$	$T_J = 25^\circ\text{C}$ , $I_{LOAD} = 1$ A	–	400	–	m $\Omega$
		$T_J = 125^\circ\text{C}$ , $I_{LOAD} = 1$ A	–	650	–	m $\Omega$
ISEN Voltage	$V_{ISEN}$		–150	–250	–350	mV
Valley Current Limit Threshold	$I_{lim}$	$R_{SENSE} = 0.27$ $\Omega$	–	740	–	mA
		$6$ V < $V_{IN1} < 8$ V	–	–	550	mA
<b>PROTECTION CIRCUITRY</b>						
NPOR Output Voltage	$V_{NPOR}$	$I_{NPOR} = 1$ mA	–	–	400	mV
NPOR Leakage Current	$I_{NPOR}$	$V_{NPOR} = 5.5$ V	–	–	1.5	$\mu$ A
NPOR Reset	$V_{NPORRESET}$	20 k $\Omega$ pullup connected to VOUT2	–	–	0.7	V
Thermal Shutdown Threshold	$T_{JTSD}$	$T_J$ rising	–	170	–	$^\circ\text{C}$
Thermal Shutdown Hysteresis	$T_{JTSDHYS}$		–	15	–	$^\circ\text{C}$

Continued on the next page...

**ELECTRICAL CHARACTERISTICS [1] (continued): Valid for Temperature Range E version at  $T_J = 25^\circ\text{C}$  and for Temperature Range K version at  $T_J = -40^\circ\text{C}$  to  $150^\circ\text{C}$ ,  $V_{IN1} = 6$  to  $50$  V (unless otherwise noted)**

Characteristics	Symbol	Test Conditions	Min.	Typ.	Max.	Unit
<b>TIMING CIRCUITRY</b>						
TSET Current, Watchdog Mode	$I_{TSETWDI}$	NPOR = high	7	10	14	$\mu\text{A}$
TSET Valley Voltage, Watchdog Mode	$V_{TRIP}$		–	1.2	–	V
TSET Reset Voltage, Watchdog Mode	$V_{RESET}$		–	0.48	–	V
WDI Frequency	$f_{WDI}$		–	–	100	kHz
WDI Duty Cycle	$DC_{WDI}$		10	–	90	%
WDI Logic Input	$V_{WDI(0)}$		$V_{IN2} \times 0.55$	–	–	V
WDI Logic Input Current [2]	$I_{WDI}$	$V_{WDI} = 0$ to $5$ V	–20	< 1.0	20	$\mu\text{A}$
WDI Input Hysteresis	$V_{WDIHYS}$		–	300	–	mV
TSET Current, Soft Start Mode	$I_{TSETSS}$	NPOR = low	14	20	26	$\mu\text{A}$
POR Current	$I_{POR}$		3.92	5.60	7.28	$\mu\text{A}$

[1] Temperature Range E version tested at  $T_J = 25^\circ\text{C}$  with performance from  $-40^\circ\text{C}$  to  $85^\circ\text{C}$  guaranteed by design and characterization.

[2] For input and output current specifications, negative current is defined as coming out of (sourcing) the specified pin.

**Power-Up and Power-Down Timing Diagrams**

Using ENB

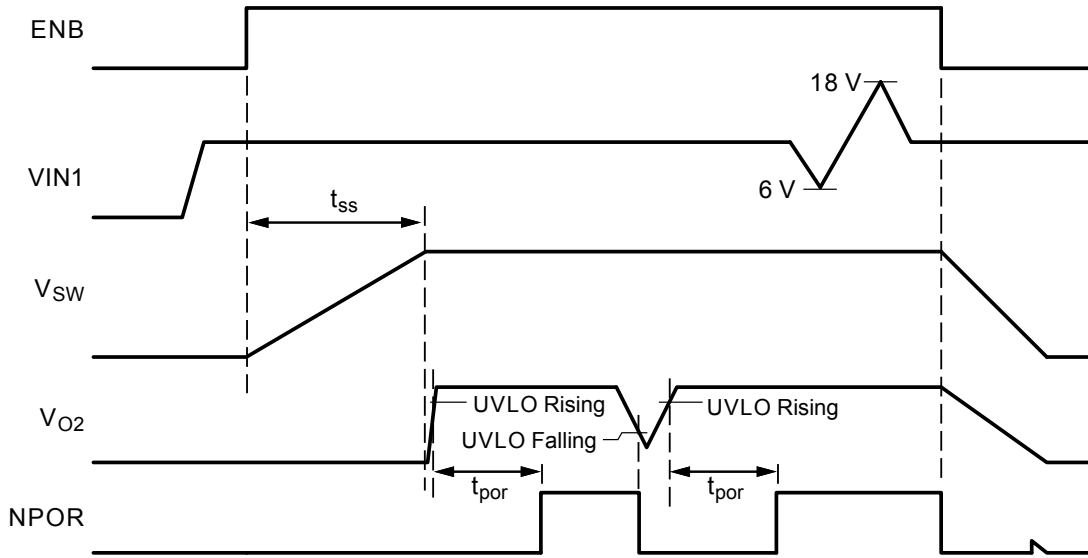

Using VIN1

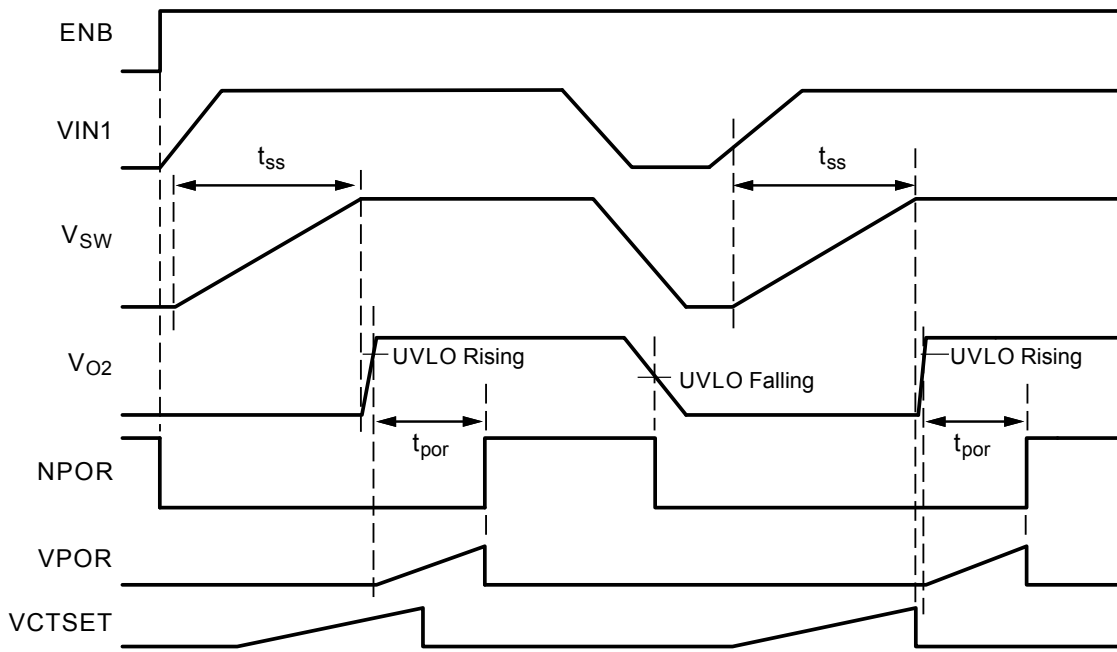

**Watchdog Timing Diagram**

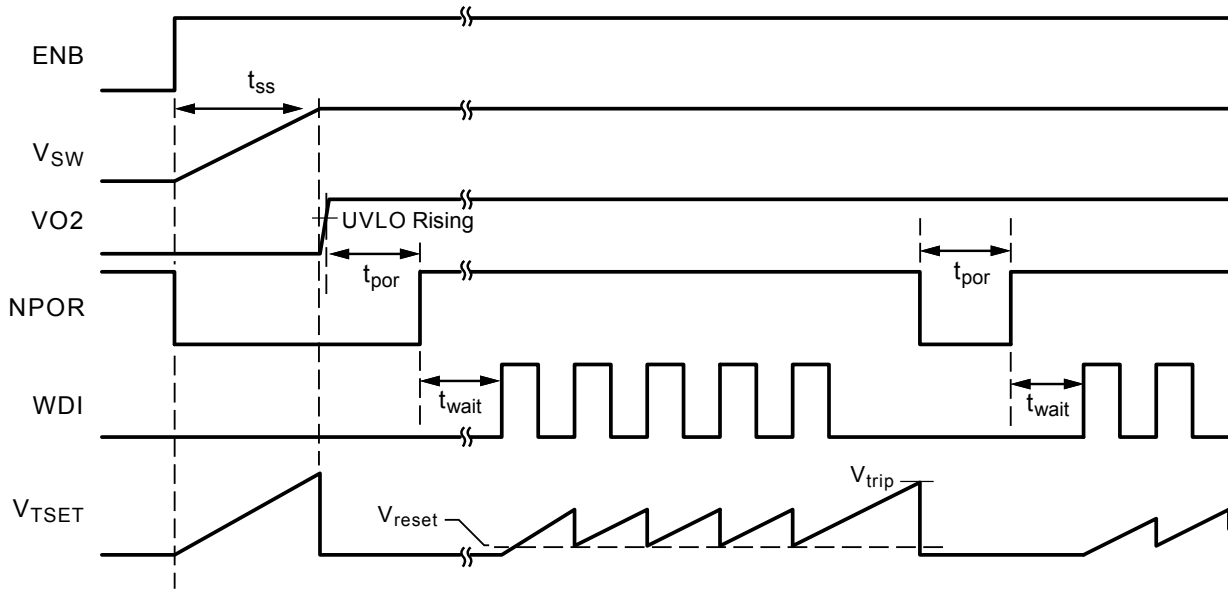

## FUNCTIONAL DESCRIPTION

## Basic Operation

The A4402 contains a fixed on-time, adjustable voltage buck switching regulator with valley sensing current mode control, and an adjustable linear regulator designed to run off the buck regulator output. The constant on-time converter maintains a constant output frequency because the on-time is inversely proportional to the supply voltage. As the input voltage decreases, the on-time is increased, maintaining a relatively constant period. Valley mode current control allows the converter to achieve very short on-times because current is measured during the off-time.

The device is enabled via the ENB input. When the ENB pin is pulled high, the converter starts-up under the control of an adjustable soft start routine whose ramp time is controlled by an external capacitor.

Under light load conditions, the switch enters pulse-skipping mode to ensure regulation is maintained. This effectively changes the switcher frequency. The frequency also is affected when the switcher is operating in discontinuous mode. In order to maintain a wide input voltage range, the switcher period is extended when either the minimum off-time at low  $V_{IN1}$ , is reached or the minimum on-time at high  $V_{IN1}$ .

## Switcher Overcurrent Protection

The converter uses pulse-by-pulse valley current limiting, which operates when the current through the sense resistor rises to  $V_{ISEN}$ . During an overload condition, the switch is turned on for a period determined by the constant on-time circuitry. The switch off-time is extended until the current decays to the current limit value set by the selection of the sense resistor, at which point the switch turns on again. Because no slope compensation is required in this control scheme, the current limit is maintained at a reasonably constant level across the input voltage range.

Figure 1 illustrates how the current is limited during an overload condition. The current decay (period with switch off) is proportional to the output voltage. As the overload is increased, the output voltage tends to decrease and the switching period increases.

## VIN1 and VIN2

VIN1 is a high voltage input, designed to withstand 50 V. Bulk capacitance of at least 10  $\mu\text{F}$  should be used to decouple input supply VIN1. The VIN2 input is used to supply the linear regulator and should be connected directly to the output of the switch-

ing regulator when the target for the  $V_{SW}$  voltage is between 3 and 5.5 V. For voltages outside of that range, the bias supply for the IC is taken from VIN1 directly and affects overall efficiency.

For applications where the switcher voltage is greater than 5 V, a second supply between 3 and 5.5 V can be used to supply VIN2 bias current and the linear regulator. Note that the current into the VIN2 supply must supply both the  $i_{dd}$  bias current and any current load on the linear regulator.

## Output Voltage Selection

The output voltage on each of the two regulators is set by a voltage divider off the regulator output, as follows:

$$V_{SW} = V_{FB1} \left( \frac{R1 + R2}{R2} \right) \quad (1)$$

$$V_{LIN} = V_{FB2} \left( \frac{R3 + R4}{R4} \right) \quad (2)$$

In order to maintain accuracy on the regulators the equivalent impedance on the FB node ( $R1$  parallel with  $R2$ ) should be approximately 10  $k\Omega$ .

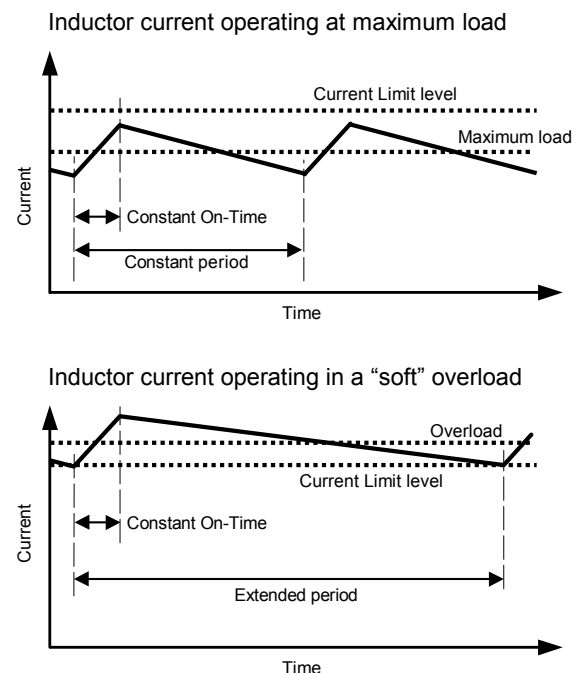

Figure 1. Current limiting during overload

**FB**

Both output regulators use a resistive feedback network to set the output voltage. To prevent introducing noise into the FB network, it is important to keep the total impedance of the FB nodes low enough to prevent noise injection. For commercial applications, it is recommended that the impedances on the FB nodes are less than 50 k $\Omega$ . For automotive applications, it is recommended that the total impedance of the FB nodes is less than 25 k $\Omega$ .

**TSET**

The TSET pin serves a dual function by controlling the timing for both the soft start ramp and the WDI input. The current sourced from the TSET pin is dependant on the state of NPOR.

There are two formulas for calculating the time constants.  $C_{TSET}$  must be selected so that both the WDI frequency and soft start requirements are met. The formulas for calculating WDI and soft start timing are:

$$t_{WDI} = 7.2 \times 10^4 \times C_{TSET} \quad , \quad \text{and} \quad (3)$$

$$t_{SS} = 6.0 \times 10^4 \times C_{TSET} \quad , \quad (4)$$

where  $C_{TSET}$  is the value of the capacitor and the results,  $t_x$ , are in s.

**Watchdog**

The WDI input is used to monitor the state of a DSP or microcontroller. A constant current is driven into the capacitor on TSET, causing the voltage on the TSET pin to ramp upward until, at each rising edge on the WDI input, the ramp is pulled down to  $V_{RESET}$ . If no edge is seen on the WDI pin before the ramp reaches  $V_{TRIP}$ , the NPOR pin is pulled low.

The watchdog timer is not activated until the WDI input sees one rising edge. If the watchdog timer is not going to be used, the WDI pin should be pulled to ground with a 4.7 k $\Omega$  resistor.

**Soft Start**

During soft start, an internal ramp generator and the external capacitor on TSET are used to ramp the output voltage in a con-

trolled fashion. This reduces the demand on the external power supply by limiting the current that charges the output capacitor and any DC load at startup. Either of the following conditions are required to trigger a soft start:

- ENB pin input rising edge
- Reset of a TSD event

When a soft start event occurs, VO2 is held in the off state until the soft start ramp timer expires. Then the regulator will power up normally. Refer to timing diagrams for details.

**BOOT**

A bootstrap capacitor is used to provide adequate charge to the NMOS switch. The boot capacitor is referenced to LX and supplies the gate drive with a voltage larger than the supply voltage. The size of the capacitor must be 0.01  $\mu$ F, X7R type, and rated for at least 25 V.

**TON**

A resistor from the TON input to VIN1 sets the on-time of the converter for a given input voltage. The formula to calculate the on-time,  $t_{ON}$  (ns), is:

$$t_{ON} = \frac{R_{TON}}{V_{IN1}} \times 3.12 \times 10^{-12} + 60 \times 10^{-9} \quad (5)$$

When the supply voltage is between 9 and 17.5 V, the switcher period remains constant, at a level based on the selected value of  $R_{ton}$ . At voltages lower than 9 V and higher than 17.5 V, the period is increased by a factor of 3.5.

If a constant period is desired over varying input voltages, it is important to select an on-time that under worst case conditions will not exceed the minimum off-time or minimum on-time of the converter. For reasonable input voltage ranges, the period of the converter can be held constant, resulting in a constant operating frequency over the input supply range.

More information on how to choose  $R_{ton}$  can be found in the Application Information section.

**ISEN**

The sense input is used to sense the current in the diode during the off-time cycle. The value for  $R_{\text{SENSE}}$  is obtained by the formula:

$$R_{\text{SENSE}} = V_{\text{ISEN}} / I_{\text{VALLEY}} \quad (6)$$

where  $I_{\text{VALLEY}}$  is the lowest current measured through the inductor during the off-time cycle.

It is recommended that the current sense resistor be sized so that, at peak output current, the voltage on ISEN does not exceed  $-0.5$  V. Because the diode current is measured when the inductor current is at the valley, the average output current is greater than the  $I_{\text{VALLEY}}$  value. The value for  $I_{\text{VALLEY}}$  should be:

$$I_{\text{VALLEY}} = I_{\text{OUT(av)}} - 0.5 I_{\text{RIPPLE}} + K \quad (7)$$

where:

$I_{\text{OUT(av)}}$  is the average of both output currents,

$I_{\text{RIPPLE}}$  is the inductor ripple current, and

$K$  is a guardband margin. The peak current in the switch is then:

$$I_{\text{PEAK}} = I_{\text{VALLEY}} + I_{\text{RIPPLE}} \quad (8)$$

The valley current must be calculated so that, at the worst-case ripple, the converter can still supply the required current to the load. Further information on how to calculate the ripple current is included in the Application Information section.

**ENB**

An active high input enables the device. When set low, the device enters sleep mode; all internal circuitry is disabled, and the part draws a maximum of  $1 \mu\text{A}$ .

**Thermal Shutdown**

When the device junction temperature,  $T_J$ , is sensed to be at  $T_{\text{JTSD}}$ , a thermal shutdown circuit disables the regulator output, protecting the A4402 from damage.

**Power-On Reset Delay**

The POR function monitors the  $V_{\text{FB2}}$  voltage and provides a signal that can be used to reset a DSP or microcontroller. A POR event is triggered by either of the following conditions:

- $V_{\text{FB2}}$  falls below its UVLO threshold. This occurs if the current limit on either regulator is exceeded, or if the switcher voltage falls due to TSD.
- After a rising edge on the WDI input, the voltage on TSET reaches  $V_{\text{TRIP}}$ .

An open drain output, through the NPOR pin, is provided to signal a POR event to the DSP or microcontroller. The reset occurs after an adjustable delay,  $t_{\text{POR}}$ , set by an external capacitor connected to the POR pin. The value of  $t_{\text{POR}}$  is calculated using the following formula:

$$t_{\text{POR}} = 214 \times 10^3 \times C_{\text{POR}} \quad (9)$$

where  $C_{\text{POR}}$  is the value of the POR capacitor in farads, and  $t_{\text{POR}}$  is the POR time in seconds.

**Shutdown**

The buck regulator will shutdown if one of the following conditions is present:

- TSD
- ENB falling edge

## APPLICATION INFORMATION

### Switcher On-Time and Switching Frequency

In order for the switcher to maintain regulation, the energy that is transferred to the inductor during the on-time must be transferred to the output capacitor during the off-time. This relationship must be maintained for stable operation and governs the fundamental operation of a switching regulator. Each component along the current path changes the voltage across the inductor and therefore the energy that is transferred during each cycle. Summing the voltage from  $V_{IN}$  to  $V_{OUT}$  during each cycle gives a relationship of the voltage across the inductor during the on-time and during the off-time. These terms are represented as  $V_{ON}$  and  $V_{OFF}$ .

Given a target operating frequency, represent  $t_{ON}$  as:

$$t_{ON} = t \times D \quad (10)$$

where  $t$  equals  $1/f_{SW}$ , and  $D$  is the duty cycle.

Duty cycle can be represented as the voltage across the inductor during the off-time, divided by the total voltage of the off-time and on-time:

$$D = V_{OFF} / (V_{OFF} + V_{ON}) \quad (11)$$

Next, determine the voltage drops during the on cycle and the off cycle. Figure 2 shows the current path during the on-time and off-time.

Creating voltage summation during each cycle will give equations to represent  $V_{ON}$  and  $V_{OFF}$ :

$$V_{ON} = V_{IN} - V_{OUT} - (I_{OUT} \times R_L) - (R_{DS} \times I_{OUT}) \quad (12)$$

$$V_{OFF} = V_{OUT} + (I_{OUT} \times R_L) + V_f + (R_S \times I_{OUT}) \quad (13)$$

Now substituting  $V_{ON}$  and  $V_{OFF}$  into equation 11 gives a complete formula for duty cycle as it relates to the voltage across the inductor:

$$D = \frac{V_{OUT} \times (I_{OUT} \times R_L) + V_f + (R_S \times I_{OUT})}{V_{OUT} + (I_{OUT} \times R_L) + V_f + (R_S \times I_{OUT}) + V_{IN} - V_{OUT} - (I_{OUT} \times R_L) - (R_{DS} \times I_{OUT})} \quad (14)$$

The effects of the voltage drop across the inductor resistance and trace resistance do have an effect on the switching frequency. However, the frequency variation due to these factors is small and is covered in the variation of the switcher period,  $t_{SW}$ , which is  $\pm 25\%$  of the target. Removing these current-dependent terms simplifies the equation:

$$D = \frac{V_{OUT} + V_f + (R_S \times I_{OUT})}{V_{OUT} + V_f + (R_S \times I_{OUT}) + V_{IN} - V_{OUT} - (R_{DS} \times I_{OUT})} \quad (15)$$

Further simplification and grouping of terms yields:

$$D = \frac{V_{OUT} + V_f + (R_S \times I_{OUT})}{V_{IN} + V_f + (R_S \times I_{OUT}) - (R_{DS} \times I_{OUT})} \quad (16)$$

Substitute this simplified expression for duty cycle back into equation 10. The following formula results in the on-time, given a target switching frequency:

$$t_{ON} = \frac{1}{f_{SW}} \left( \frac{V_{OUT} + V_f + (R_S \times I_{OUT})}{V_{IN} + V_f + (R_S \times I_{OUT}) - (R_{DS} \times I_{OUT})} \right) \quad (17)$$

The formulas above describe how  $t_{ON}$  changes based on input and load conditions. Because load changes are minimal, and the output voltage is fixed, the dominant factor that effects on-time is the input voltage. The converter is able to maintain a constant period over a varying supply voltage because the on-time is proportional to the input voltage. The current into the TON terminal is derived from a resistor tied to VIN1, which sets the on-time proportional to the supply voltage. Selecting the resistor value, based on the  $t_{ON}$  calculated above, is done using the following formula:

$$R_{TON} = \frac{(t_{ON} - 60 \times 10^{-9}) \times V_{IN}}{3.12 \times 10^{-12}} \quad (18)$$

After the resistor is selected and a suitable  $t_{ON}$  is found, it must be demonstrated that  $t_{ON}$  does not, under worst-case conditions, exceed the minimum on-time or minimum off-time of the converter. The minimum on-time occurs at maximum input voltage and minimum load. The maximum off-time occurs at minimum supply voltage and maximum load. For supply voltages below 9.5 V and above 17 V, refer to the Low and High Voltage Operation section.

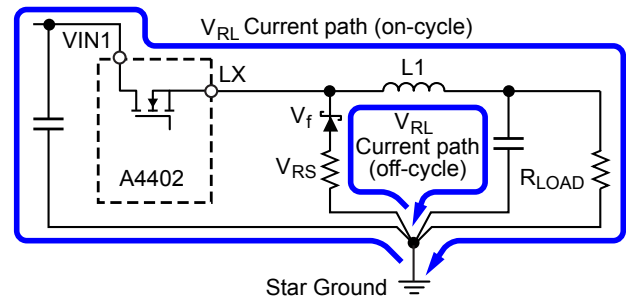

Figure 2. Current limiting during overload

### Low and High Voltage Operation

The converter can run at very low input voltages. With a 5 V output, the minimum input supply can be as low as 6 V. When operating at high frequencies, the on-time of the converter must be very short because the available period is short. At high input voltages the converter must maintain very short on-times, while at low input voltages the converter must maintain long off-times. Rather than limit the supply voltage range, the converter solves this problem by automatically increasing the period by a factor of 3.5. With the period extended, the converter will not violate the minimum on-time or off-time. If the input voltage is between 9.5 and 17 V, the converter will maintain a constant period. When calculating worst-case on-times and off-times, make sure to use the multiplier if the supply voltage is between those values.

When operating at voltages below 8 V, additional care must be taken when selecting the inductor and diode. At low voltages the maximum current may be limited due to the IR drops in the current path. When selecting external components for low voltage operation, the IR drops must be considered when determining on-time, so the complete formula should be used to make sure the converter does not violate the timing specification.

### Inductor Selection

Choosing the right inductor is critical to the correct operation of the switcher. The converter is capable of running at frequencies above 2 MHz. This makes it possible to use small inductor values, which reduces cost and board area.

The inductor value is what determines the ripple current. It is important to size the inductor so that under worst-case conditions  $I_{\text{VALLEY}}$  equals  $I_{\text{AV}}$  minus half the ripple current plus reasonable margin. If the ripple current is too large, the converter will be current limited. Typically peak-to-peak ripple current should be limited to 20% to 25% of the maximum average load current.

Worst-case ripple current occurs at maximum supply voltage. After calculating the duty cycle, DC, for this condition, the ripple current can be calculated. First to calculate DC:

$$\text{DC} = \frac{V_{\text{SW}} + V_f + (R_{\text{SENSE}} \times I_{\text{PEAK}})}{V_{\text{IN1(max)}} + V_f + (R_{\text{SENSE}} \times I_{\text{PEAK}})} \quad (19)$$

Using the duty cycle, a ripple current can be calculated using the following formula:

$$L = \frac{V_{\text{IN1}} - V_{\text{OUT}}}{I_{\text{RIPPLE}}} \times \text{DC} \times \frac{1}{f_{\text{SW(min)}}} \quad (20)$$

where  $I_{\text{RIPPLE}}$  is 25% of the maximum load current, and  $f_{\text{SW(min)}}$  is the minimum switching frequency (nominal frequency minus 25%). For the example used above, a 1 A converter with a supply voltage of 13.5 V was the design objective. The supply voltage can vary by  $\pm 10\%$ . The output voltage is 5 V,  $V_f$  is 0.5 V,  $V_{\text{SENSE}}$  is 0.15, and the desired frequency is 2.0 MHz. The duty cycle is calculated to be 36.45%. The worst-case frequency is 2 MHz minus 20% or 1.6 MHz. Using these numbers in the above formula shows that the minimum inductance for this converter is 9.6  $\mu\text{H}$ .

### Output Capacitor

The converter is designed to operate with a low-value ceramic output capacitor. When choosing a ceramic capacitor, make sure the rated voltage is at least 3 times the maximum output voltage of the converter. This is because the capacitance of a ceramic decreases as they operate closer to their rated voltage. It is recommended that the output be decoupled with a 10  $\mu\text{F}$ , X7R ceramic capacitor. Larger capacitance may be required on the outputs if load surges dramatically influence the output voltage.

Output ripple is determined by the output capacitance and the effects of ESR and ESL can be ignored assuming recommended layout techniques are followed. The output voltage ripple is approximated by:

$$V_{\text{RIPPLE}} = \frac{I_{\text{RIPPLE}}}{4 \times f_{\text{SW}} \times C_{\text{OUT}}} \quad (21)$$

### Input Capacitor

The value of the input capacitance affects the amount of current ripple on the input. This current ripple is usually the source of supply-side EMI. The amount of interference depends on the impedance from the input capacitor and the bulk capacitance located on the supply bus. Adding a small value, 0.1  $\mu\text{F}$ , ceramic capacitor as close to the input supply pin as possible can reduce EMI effects. The small capacitor will help reduce high frequency transient currents on the supply line. If further filtering is needed it, is recommended that two ceramic capacitors be used in parallel to further reduce emissions.

### Rectification Diode

The diode conducts the current during the off-cycle. A Schottky diode is needed to minimize the forward drop and switching losses. In order to size the diode correctly, it is necessary to find the average diode conduction current using the formula below:

$$I_{D(av)} = I_{LOAD} \times (1 - DC(min)) \quad , \quad (22)$$

where DC (min) is defined as:

$$DC (min) = \frac{V_{SW} + V_f}{V_{IN1} + V_f} \quad , \quad (23)$$

where  $V_{IN1}$  is the maximum input voltage and  $V_f$  is the maximum forward voltage of the diode.

Average power dissipation in the diode is:

$$P_{D(diode)} = I_{LOAD(av)} \times DC(min) \times V_f \quad , \quad (24)$$

The power dissipation in the sense resistor must also be considered using  $I^2R$  and the minimum duty cycle.

### PCB Layout

The board layout has a large impact on the performance of the device. It is important to isolate high current ground returns, to minimize ground bounce that could produce reference errors in the device. The method used to isolate power ground from noise sensitive circuitry is to use a star ground. This approach makes

sure the high current components such as the input capacitor, output capacitor, and diode have very low impedance paths to each other. Figure 3 illustrates the technique.

The ground from each of the components should be very close to each other and be connected on the same surface as the components. Internal ground planes should not be used for the star ground connection, as vias add impedance to the current path.

In order to further reduce noise effects on the PCB, noise sensitive traces should not be connected to internal ground planes. The feedback network from the switcher output should have an independent ground trace that goes directly to the exposed pad underneath the device. The exposed pad should be connected to internal ground planes and to any exposed copper used for heat dissipation. If the grounds from the device are also connected directly to the exposed pad the ground reference from the feedback network will be less susceptible to noise injection or ground bounce.

To reduce radiated emissions from the high frequency switching nodes, it is important to have an internal ground plane directly under the LX node. The plane should not be broken directly under the node as the lowest impedance path back to the star ground would be directly under the signal trace. If another trace does break the return path, the energy will have to find another path, which is through radiated emissions.

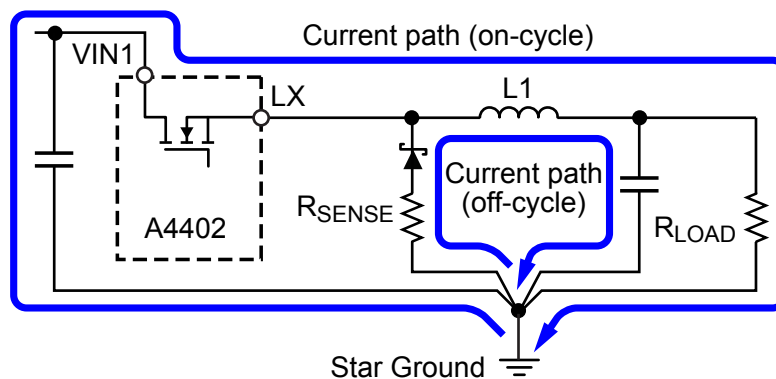
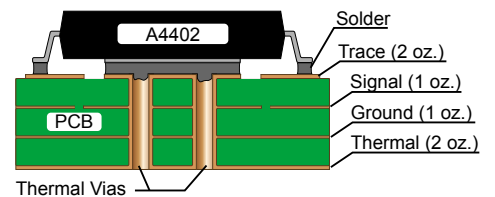
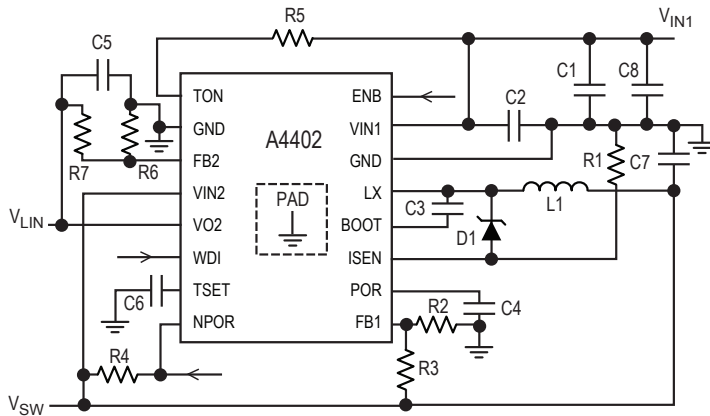
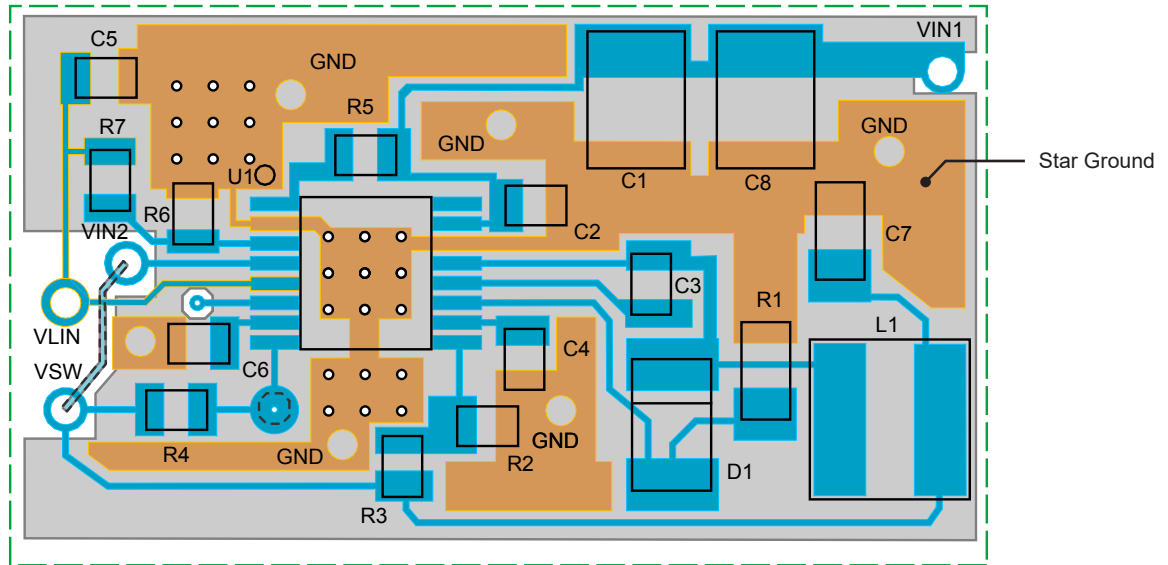

Figure 3. Star Ground Connection

### PCB LAYOUT DIAGRAM



### PIN CIRCUIT DIAGRAMS

#### Power Terminals

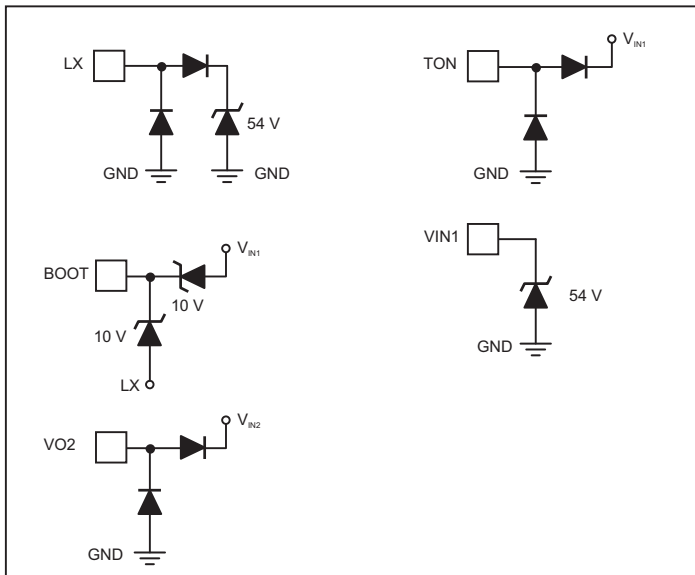

#### Logic Terminals

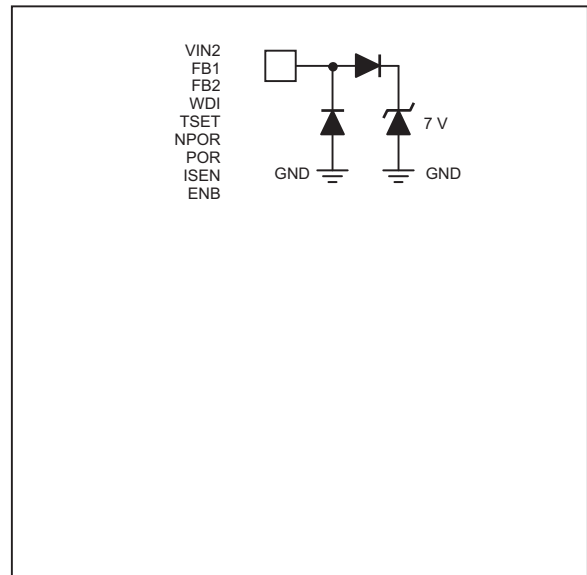

## Package LP, 16-Pin eTSSOP with Exposed Thermal Pad

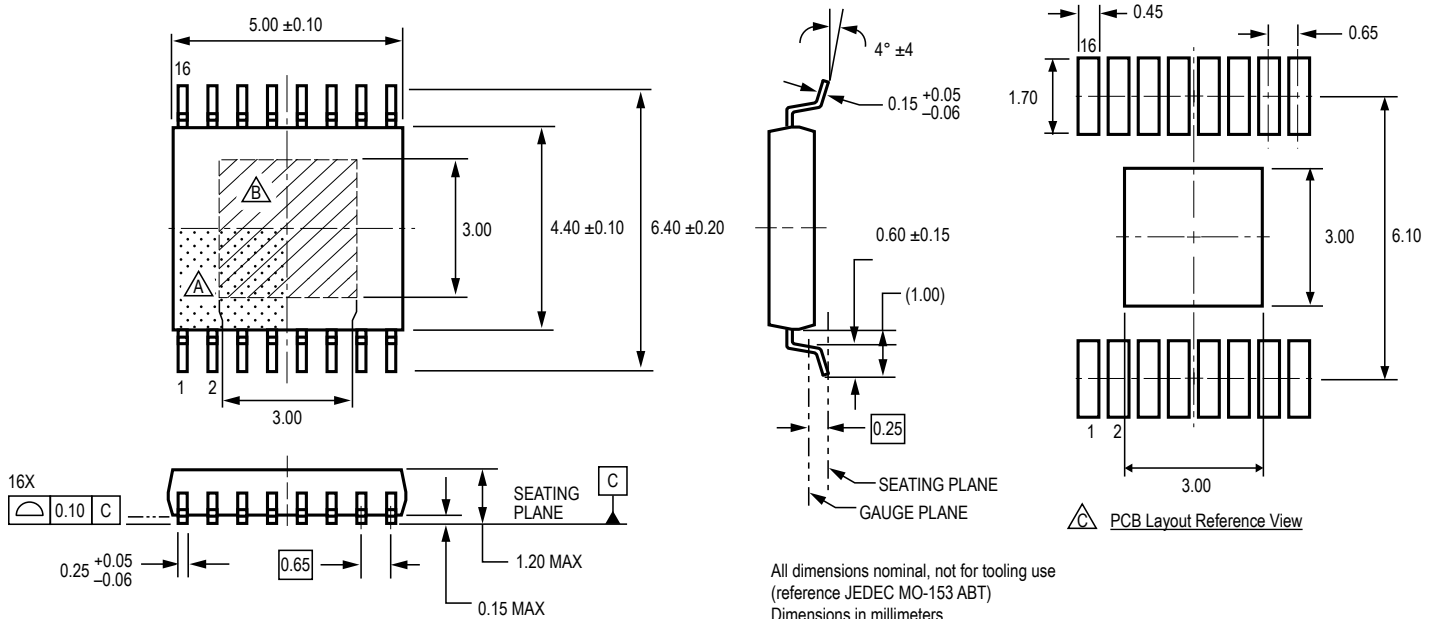

- All dimensions nominal, not for tooling use  
(reference JEDEC MO-153 ABT)  
Dimensions in millimeters  
Dimensions exclusive of mold flash, gate burrs, and dambar protrusions  
Exact case and lead configuration at supplier discretion within limits shown
- Terminal #1 mark area
  - Exposed thermal pad (bottom surface)
  - Reference land pattern layout (reference IPC7351 SOP65P640X110-17M); All pads a minimum of 0.20 mm from all adjacent pads; adjust as necessary to meet application process requirements and PCB layout tolerances; when mounting on a multilayer PCB, thermal vias at the exposed thermal pad land can improve thermal dissipation (reference EIA/JEDEC Standard JESD51-5)

**Revision History**

<b>Number</b>	<b>Date</b>	<b>Description</b>
10	August 27, 2013	Update TON description
11	March 26, 2014	Revised Functional Description and Pin Circuits
12	November 28, 2017	Corrected Equations 3 and 4 on page 10
13	December 14, 2019	Minor editorial updates

Copyright ©2019, Allegro MicroSystems, LLC

Allegro MicroSystems, LLC reserves the right to make, from time to time, such departures from the detail specifications as may be required to permit improvements in the performance, reliability, or manufacturability of its products. Before placing an order, the user is cautioned to verify that the information being relied upon is current.

Allegro's products are not to be used in any devices or systems, including but not limited to life support devices or systems, in which a failure of Allegro's product can reasonably be expected to cause bodily harm.

The information included herein is believed to be accurate and reliable. However, Allegro MicroSystems, LLC assumes no responsibility for its use; nor for any infringement of patents or other rights of third parties which may result from its use.

Copies of this document are considered uncontrolled documents.

For the latest version of this document, visit our website:

[www.allegromicro.com](http://www.allegromicro.com)

## Looking for pricing, stock, or lifecycle information?

Click below to explore more details on WIN SOURCE:

- ⊖ [View A4402KLPTR-T on WIN SOURCE](#)
- ⊖ [Allegro MicroSystems, LLC Information](#)

## Optimize Your Supply Chain with WIN SOURCE Solutions

- ✓ Global Sourcing Solution
- ✓ Obsolete Management
- ✓ Cost Control Management
- ✓ Shortage Management
- ✓ Alternative Solution
- ✓ Excess Inventory Management