

USB332x

Industry's Smallest Hi-Speed USB Transceiver with 1.8V ULPI Interface



PRODUCT FEATURES

[Datasheet](#)

- Integrated ESD protection circuits
 - Up to ±15kV IEC Air Discharge without external devices
- Over-Voltage Protection circuit (OVP) protects the VBUS pin from continuous DC voltages up to 30V
- Integrated USB Switch
 - No degradation of Hi-Speed electrical characteristics
 - Allows single USB port of connection by providing switching function for:
 - Battery charging
 - Stereo and mono/mic audio
 - USB Full-Speed/Low-Speed data
- flexPWR[®] Technology
 - Low current design ideal for battery powered applications
 - “Sleep” mode tri-states all ULPI pins and places the part in a low current state
 - 1.8V IO Voltage (±10%)
- Integrated battery to 3.3V LDO regulator
 - 2.2µF bypass capacitor
 - 100mV dropout voltage
- “Wrapper-less” design for optimal timing performance and design ease
 - Low Latency Hi-Speed Receiver (43 Hi-Speed clocks Max) allows use of legacy UTMI Links with a ULPI bridge
- External Reference Clock operation
 - ULPI Input Clock Mode (60MHz sourced by Link)
 - 0 to 3.6V input drive tolerant
 - Able to accept “noisy” clock sources as reference to internal, low-jitter PLL
 - Frequencies: 12, 13, 19.2, 26, or 27MHz
- Smart detection circuits allow identification of USB charger, headset, or data cable insertion
- Includes full support for the optional On-The-Go (OTG) protocol detailed in the On-The-Go Supplement Revision 2.0 specification
- Supports the OTG Host Negotiation Protocol (HNP) and Session Request Protocol (SRP)
- UART mode for non-USB serial data transfers

- Internal 5V cable short-circuit protection of ID, DP and DM lines to VBUS or ground
- Industrial Operating Temperature -40°C to +85°C
- 25 ball WLCSP lead-free RoHS compliant package; (2.0 x 2.0 x 0.53mm height)

Applications

The USB332x is targeted for any application where a Hi-Speed USB connection is desired and when board space, power, and interface pins must be minimized.

The USB332x is well suited for:

- Cell Phones
- PDAs
- MP3 Players
- GPS Personal Navigation Devices
- Datacards
- Scanners
- External Hard Drives
- Digital Still and Video Cameras
- Portable Media Players
- Entertainment Devices
- Printers
- HDTVs
- Set Top Boxes/DVR/PVR
- Video Record/Playback Systems
- IP and Video Phones
- Gaming Consoles
- POS Terminals

Datasheet

Order Numbers

ORDER NUMBER	REFCLK FREQUENCY (Note 0.1)	PACKAGE TYPE	REEL SIZE
USB3321C-GL-TR	26MHz	25 Ball, WLCSP Lead-Free RoHS Compliant Package (tape and reel)	3000 pieces
USB3322C-GL-TR	12MHz		
USB3326C-GL-TR	19.2MHz		
USB3327C-GL-TR	27MHz		
USB3329C-GL-TR	13MHz		

Note 0.1 All versions support ULPI Clock In Mode (60MHz input at REFCLK)

This product meets the halogen maximum concentration values per IEC61249-2-21

For RoHS compliance and environmental information, please visit www.smSC.com/rohs

Please contact your SMSC sales representative for additional documentation related to this product such as application notes, anomaly sheets, and design guidelines.

Copyright © 2012 SMSC or its subsidiaries. All rights reserved.

Circuit diagrams and other information relating to SMSC products are included as a means of illustrating typical applications. Consequently, complete information sufficient for construction purposes is not necessarily given. Although the information has been checked and is believed to be accurate, no responsibility is assumed for inaccuracies. SMSC reserves the right to make changes to specifications and product descriptions at any time without notice. Contact your local SMSC sales office to obtain the latest specifications before placing your product order. The provision of this information does not convey to the purchaser of the described semiconductor devices any licenses under any patent rights or other intellectual property rights of SMSC or others. All sales are expressly conditional on your agreement to the terms and conditions of the most recently dated version of SMSC's standard Terms of Sale Agreement dated before the date of your order (the "Terms of Sale Agreement"). The product may contain design defects or errors known as anomalies which may cause the product's functions to deviate from published specifications. Anomaly sheets are available upon request. SMSC products are not designed, intended, authorized or warranted for use in any life support or other application where product failure could cause or contribute to personal injury or severe property damage. Any and all such uses without prior written approval of an Officer of SMSC and further testing and/or modification will be fully at the risk of the customer. Copies of this document or other SMSC literature, as well as the Terms of Sale Agreement, may be obtained by visiting SMSC's website at <http://www.smSC.com>. SMSC is a registered trademark of Standard Microsystems Corporation ("SMSC"). Product names and company names are the trademarks of their respective holders.

The Microchip name and logo, and the Microchip logo are registered trademarks of Microchip Technology Incorporated in the U.S.A. and other countries.

SMSC DISCLAIMS AND EXCLUDES ANY AND ALL WARRANTIES, INCLUDING WITHOUT LIMITATION ANY AND ALL IMPLIED WARRANTIES OF MERCHANTABILITY, FITNESS FOR A PARTICULAR PURPOSE, TITLE, AND AGAINST INFRINGEMENT AND THE LIKE, AND ANY AND ALL WARRANTIES ARISING FROM ANY COURSE OF DEALING OR USAGE OF TRADE. IN NO EVENT SHALL SMSC BE LIABLE FOR ANY DIRECT, INCIDENTAL, INDIRECT, SPECIAL, PUNITIVE, OR CONSEQUENTIAL DAMAGES; OR FOR LOST DATA, PROFITS, SAVINGS OR REVENUES OF ANY KIND; REGARDLESS OF THE FORM OF ACTION, WHETHER BASED ON CONTRACT; TORT; NEGLIGENCE OF SMSC OR OTHERS; STRICT LIABILITY; BREACH OF WARRANTY; OR OTHERWISE; WHETHER OR NOT ANY REMEDY OF BUYER IS HELD TO HAVE FAILED OF ITS ESSENTIAL PURPOSE, AND WHETHER OR NOT SMSC HAS BEEN ADVISED OF THE POSSIBILITY OF SUCH DAMAGES.

0.1 Reference Documents

- Universal Serial Bus Specification, Revision 2.0, April 27, 2000
- On-The-Go Supplement to the USB 2.0 Specification, Revision 2.0, May 8, 2009
- 27% Resistor ECN
- USB 2.0 Transceiver Macrocell Interface (UTMI) Specification, Version 1.12, May 27, 2000
- UTMI+ Specification, Revision 1.1, February 25, 2004
- UTMI+ Low Pin Interface (ULPI) Specification, Revision 1.1, October 20th, 2004
- Technical Requirements and Test Methods of Charger and Interface for Mobile Telecommunication Terminal Equipment (Chinese Charger Specification Approval Draft 11/29/2006)

Table of Contents

0.1	Reference Documents	3
<hr/>		
Chapter 1	General Description	8
<hr/>		
Chapter 2	USB332x Pin Locations and Definitions	10
2.1	USB332x Ball Locations and Descriptions	10
2.1.1	Package Diagram with Ball Locations	10
2.1.2	Ball Definitions	10
<hr/>		
Chapter 3	Limiting Values	13
3.1	Absolute Maximum Ratings	13
3.2	Recommended Operating Conditions	13
<hr/>		
Chapter 4	Electrical Characteristics	14
4.1	Operating Current	14
4.2	Clock Specifications	15
4.3	ULPI Interface Timing	15
4.4	Digital IO Pins	16
4.5	DC Characteristics: Analog I/O Pins	16
4.6	Dynamic Characteristics: Analog I/O Pins	18
4.7	OTG Electrical Characteristics	19
4.8	USB Audio Switch Characteristics	19
4.9	Regulator Output Voltages and Capacitor Requirement	20
<hr/>		
Chapter 5	Architecture Overview	21
5.1	ULPI Digital Operation and Interface	21
5.2	USB 2.0 Hi-Speed Transceiver	21
5.2.1	USB Transceiver	21
5.2.2	Termination Resistors	22
5.3	Bias Generator	24
5.4	Integrated Low Jitter PLL	24
5.4.1	REFCLK Frequency Selection	24
5.4.2	REFCLK Amplitude	25
5.4.3	REFCLK Jitter	26
5.4.4	REFCLK Enable/Disable	26
5.5	Internal Regulators and POR	27
5.5.1	Integrated Low Dropout Regulator	27
5.5.2	Power On Reset (POR)	29
5.5.3	Recommended Power Supply Sequence	29
5.5.4	Start-Up	29
5.6	USB On-The-Go (OTG)	30
5.6.1	ID Resistor Detection	30
5.6.2	VBUS Monitor and Pulsing	33
5.6.3	Driving External VBUS	36
5.7	USB UART Support	36
5.8	USB Charger Detection Support	36
5.9	USB Audio Support	36
<hr/>		
Chapter 6	ULPI Operation	38
6.1	Overview	38
6.1.1	ULPI Interface Signals	39
6.1.2	ULPI Interface Timing in Synchronous Mode	40

6.2	ULPI Register Access	40
6.2.1	ULPI Register Write	41
6.2.2	ULPI Register Read	43
6.2.3	ULPI RXCMD	44
6.2.4	USB332x Transmitter	45
6.2.5	USB Receiver	47
6.3	Low Power Mode	48
6.3.1	Entering Low Power/Suspend Mode	49
6.3.2	Exiting Low Power Mode	50
6.3.3	Interface Protection	50
6.3.4	Minimizing Current in Low Power Mode	51
6.4	Full Speed/Low Speed Serial Modes	52
6.5	Carkit Mode	53
6.5.1	USB UART Mode	54
6.5.2	USB Audio Mode	55
6.6	RID Converter Operation	55
6.7	Headset Audio Mode	55
<hr/>		
Chapter 7 ULPI Register Map		57
7.1	ULPI Register Array	57
7.1.1	ULPI Register Set	58
7.1.2	Carkit Control Registers	63
7.1.3	Vendor Register Access	65
<hr/>		
Chapter 8 Application Notes		69
8.1	Application Diagram	69
8.2	Reference Designs	71
8.3	ESD Performance	71
8.3.1	Human Body Model (HBM) Performance	71
8.3.2	EN/IEC 61000-4-2 Performance	72
8.3.3	Air Discharge	72
8.3.4	Contact Discharge	72
<hr/>		
Chapter 9 Package Outline, Tape & Reel Drawings, Package Marking		73
<hr/>		
Chapter 10 Revision History		78

Datasheet

List of Figures

Figure 1.1	USB332x Block Diagram	8
Figure 2.1	USB332x Ball Locations - Top View	10
Figure 5.1	USB332x System Diagram	21
Figure 5.2	Configuring the USB332X for ULPI Clock In Mode (60 MHz)	25
Figure 5.3	Configuring the USB332X for ULPI Clock Out Mode	25
Figure 5.4	Example of circuit used to shift a reference clock common-mode voltage level	26
Figure 5.5	Powering the USB332x from a Battery	27
Figure 5.6	Powering the USB332x from a 3.3V Supply	28
Figure 5.7	Powering the USB332x from VBUS	28
Figure 5.8	ULPI Start-up Timing	30
Figure 5.9	USB332x ID Resistor Detection Circuitry	31
Figure 5.10	USB332x OTG VBUS Block	33
Figure 6.1	ULPI Digital Block Diagram	38
Figure 6.2	ULPI Single Data Rate Timing Diagram in Synchronous Mode	40
Figure 6.3	ULPI Register Write in Synchronous Mode	41
Figure 6.4	ULPI Extended Register Write in Synchronous Mode	42
Figure 6.5	ULPI Register Read in Synchronous Mode	43
Figure 6.6	ULPI Extended Register Read in Synchronous Mode	44
Figure 6.7	ULPI Transmit in Synchronous Mode	47
Figure 6.8	ULPI Receive in Synchronous Mode	48
Figure 6.9	Entering Low Power Mode from Synchronous Mode	49
Figure 6.10	Exiting Low Power Mode	50
Figure 8.1	USB332x WLCSP Application Diagram (Device configured for ULPI Clock Out mode)	70
Figure 8.2	USB332x WLCSP Application Diagram (Host or OTG configured for ULPI Clock In mode)	71
Figure 9.1	25WLCSP, 2.0x2.0mm Body, 0.4mm Pitch	73
Figure 9.2	25WLCSP, 1.97x1.97 Tape and Reel	74
Figure 9.3	25WLCSP, 1.97x1.97 Reel Dimensions	75
Figure 9.4	25WLCSP, 1.97x1.97 Tape Sections	76
Figure 9.5	Reflow Profile and Critical Parameters for Lead-free (SnAgCu) Solder	76
Figure 9.6	25WLCSP, 2x2 Package Marking	77

List of Tables

Table 2.1	USB332x Pin Description	10
Table 3.1	Absolute Maximum Ratings	13
Table 3.2	Recommended Operating Conditions	13
Table 4.1	Operating Current	14
Table 4.2	ULPI Clock Specifications	15
Table 4.3	ULPI Interface Timing	15
Table 4.4	Digital IO Characteristics: RESETB, STP, DIR, NXT, DATA[7:0], and REFCLK Pins	16
Table 4.5	DC Characteristics: Analog I/O Pins (DP/DM)	16
Table 4.6	Dynamic Characteristics: Analog I/O Pins (DP/DM)	18
Table 4.7	OTG Electrical Characteristics	19
Table 4.8	USB Audio Switch Characteristics	19
Table 4.9	Regulator Output Voltages and Capacitor Requirement	20
Table 4.10	ESD and LATCH-UP Performance	20
Table 5.1	DP/DM Termination vs. Signaling Mode	22
Table 5.2	Operating Mode vs. Power Supply Configuration	29
Table 5.3	Valid Values of ID Resistance to Ground	32
Table 5.4	IdGnd and IdFloat vs. ID Resistance to Ground	32
Table 5.5	External VBUS Indicator Logic	34
Table 5.6	Required RVBUS Resistor Value	35
Table 5.7	USB Weak Pull-up Enable	36
Table 5.8	USB Audio Switch Enable	37
Table 6.1	ULPI Interface Signals	39
Table 6.2	ULPI TXD CMD Byte Encoding	41
Table 6.3	ULPI RX CMD Encoding	45
Table 6.4	Interface Signal Mapping During Low Power Mode	49
Table 6.5	Pin Definitions in 3 pin Serial Mode	52
Table 6.6	Pin Definitions in 6 pin Serial Mode	53
Table 6.7	ULPI Register Programming Example to Enter UART Mode	54
Table 6.8	Pin Definitions in CarKit Mode	54
Table 6.9	ULPI Register Programming Example to Enter Audio Mode	55
Table 6.10	Pin Definitions in Headset Audio Mode	56
Table 7.1	ULPI Register Map	57
Table 8.1	Component Values in Application Diagrams	69
Table 8.2	Capacitance Values at VBUS of USB Connector	69
Table 10.1	Customer Revision History	78

Chapter 1 General Description

SMSC's USB332x is a family of Hi-Speed USB 2.0 Transceivers that provides a physical layer (PHY) solution well-suited for portable electronic devices. Both commercial and industrial temperature applications are supported.

Each model in the USB332x family may use a 60MHz reference clock, or the model-number specific reference clock shown in [Order Numbers](#) on page 2.

Several advanced features make the USB332x the transceiver of choice by reducing both electrical bill of material (eBOM) part count and printed circuit board (PCB) area. Outstanding ESD robustness eliminates the need for external ESD protection devices in typical applications. The internal Over-Voltage Protection circuit (OVP) protects the USB332x from voltages up to 30V. By using a reference clock from the Link, the USB332x removes the cost of a dedicated crystal reference from the design. And the integrated USB switch enables unique product features with a single USB port of connection.

The USB332x meets all of the electrical requirements to be used as a Hi-Speed USB Host, Device, or an On-the-Go (OTG) transceiver. In addition to the supporting USB signaling, the USB332x also provides USB UART mode and USB Audio mode.

USB332x uses the industry standard UTMI+ Low Pin Interface (ULPI) to connect the USB PHY to the Link. ULPI uses a method of in-band signaling and status byte transfers between the Link and PHY to facilitate a USB session with only 12 pins.

The USB332x uses SMSC's "wrapper-less" technology to implement the ULPI interface. This "wrapper-less" technology allows the PHY to achieve a low latency transmit and receive time. SMSC's low latency transceiver allows an existing UTMI Link to be reused by adding a UTMI to ULPI bridge. By adding a bridge to the ASIC the existing and proven UTMI Link IP can be reused.

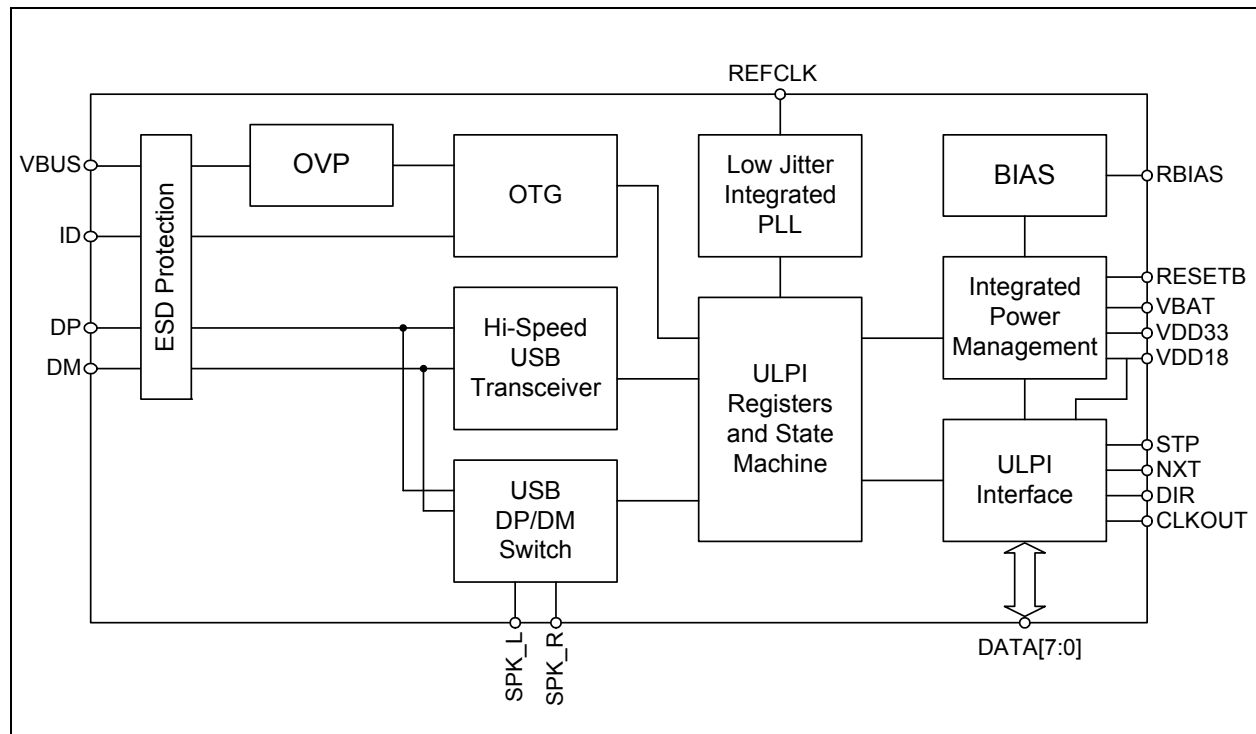

Figure 1.1 USB332x Block Diagram

The USB332x includes an integrated 3.3V Low Drop Out (LDO) linear voltage regulator that may optionally be used to generate 3.3V from power applied at the **VBAT** pin. The voltage on the **VBAT** pin can range from 3.1 to 5.5V. The regulator dropout voltage is less than 100mV which allows the PHY to continue USB signaling when the voltage on **VBAT** drops to 3.1V. The USB transceiver will continue to operate at lower voltages, although some parameters may be outside the limits of the USB specifications. If the user would like to provide a 3.3V supply to the USB332x, the **VBAT** and **VDD33** pins should be connected together as described in [Section 5.5.1](#).

The USB332x also includes integrated pull-up resistors that can be used for detecting the attachment of a USB Charger. By sensing the attachment to a USB Charger, a product using the USB332x can charge its battery at more than the 500mA allowed when charging from a USB Host as described in [Section 8.2](#).

In USB UART mode, the USB332x **DP** and **DM** pins are redefined to enable pass-through of asynchronous serial data. The USB332x can only enter UART mode when the user programs the part into this mode, as described in [Section 6.5.1](#).

In USB audio mode, a switch connects the **DP** pin to the **SPK_R** pin, and another switch connects the **DM** pin to the **SPK_L** pin. These switches are shown in the lower left-hand corner of [Figure 5.1](#). The USB332x can be configured to enter USB audio mode as described in [Section 6.5.2](#). In addition, these switches are on when the **RESETB** pin of the USB332x is asserted. The USB audio mode enables audio signalling from a single USB port of connection, and the switches may also be used to connect Full Speed USB from another PHY onto the USB cable.

Chapter 2 USB332x Pin Locations and Definitions

2.1 USB332x Ball Locations and Descriptions

2.1.1 Package Diagram with Ball Locations

The illustration below is viewed from the top of the package.

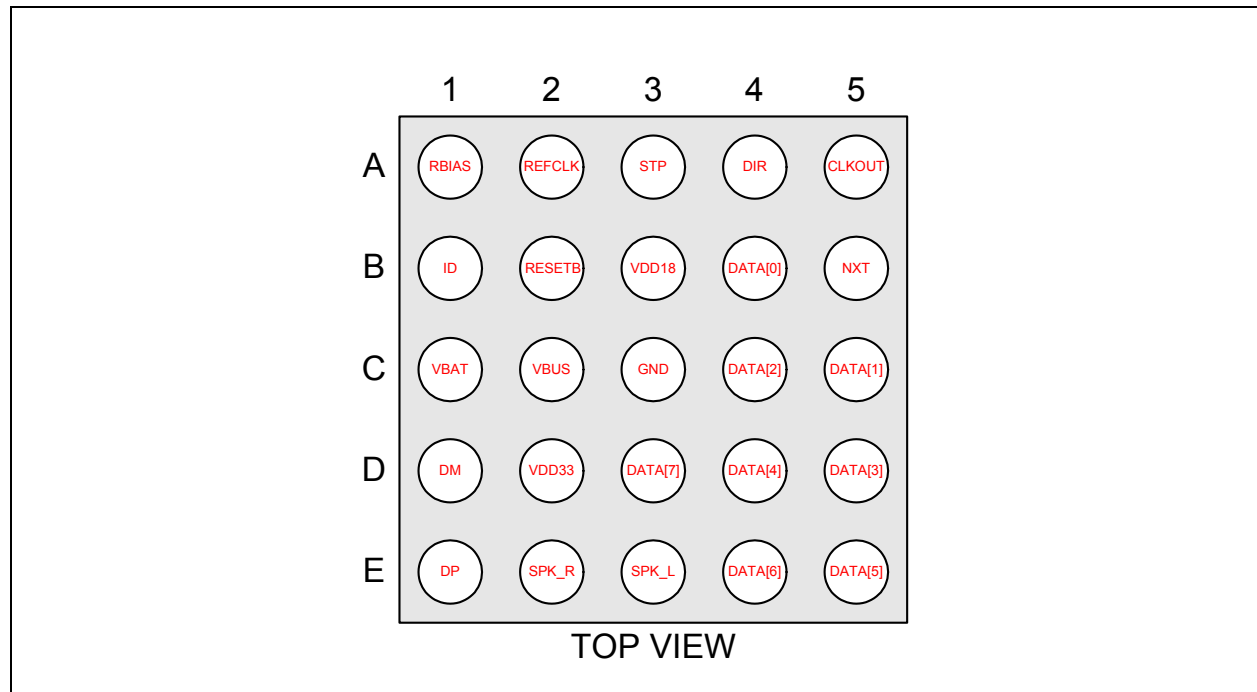

Figure 2.1 USB332x Ball Locations - Top View

2.1.2 Ball Definitions

The following table details the ball definitions for the figure above.

Table 2.1 USB332x Pin Description

BALL	NAME	DIRECTION/ TYPE	ACTIVE LEVEL	DESCRIPTION
B1	ID	Input, Analog	N/A	ID pin of the USB cable. For applications not using ID this pin can be connected to VDD33 . For an A-Device ID is grounded. For a B-Device ID is floated.
C2	VBUS	I/O, Analog	N/A	This pin connects to an external resistor (R_{VBUS}) connected to the VBUS pin of the USB cable. This pin is used for the VBUS comparator inputs and for VBUS pulsing during session request protocol. See Table 5.6, "Required RVBUS Resistor Value" .
C1	VBAT	Power	N/A	Regulator input.

Table 2.1 USB332x Pin Description (continued)

BALL	NAME	DIRECTION/ TYPE	ACTIVE LEVEL	DESCRIPTION
D2	VDD33	Power	N/A	3.3V Regulator Output. A 2.2uF (<1 ohm ESR) bypass capacitor to ground is required for regulator stability. The bypass capacitor should be placed as close as possible to the USB332x.
D1	DM	I/O, Analog	N/A	D- pin of the USB cable.
E1	DP	I/O, Analog	N/A	D+ pin of the USB cable.
E2	SPK_R	I/O, Analog	N/A	USB switch in/out for DP signals
E3	SPK_L	I/O, Analog	N/A	USB switch in/out for DM signals
D3	DATA[7]	I/O, CMOS	N/A	ULPI bi-directional data bus. DATA[7] is the MSB.
E4	DATA[6]	I/O, CMOS	N/A	ULPI bi-directional data bus.
E5	DATA[5]	I/O, CMOS	N/A	ULPI bi-directional data bus.
D4	DATA[4]	I/O, CMOS	N/A	ULPI bi-directional data bus.
A5	CLKOUT	Output, CMOS	N/A	ULPI Clock Out Mode: 60MHz ULPI clock output. All ULPI signals are driven synchronous to the rising edge of this clock. ULPI Clock In Mode: This pin is connected to VDD18 to configure 60MHz ULPI Clock IN mode as described in Section 5.4.1 .
D5	DATA[3]	I/O, CMOS	N/A	ULPI bi-directional data bus.
C4	DATA[2]	I/O, CMOS	N/A	ULPI bi-directional data bus.
C5	DATA[1]	I/O, CMOS	N/A	ULPI bi-directional data bus.
B4	DATA[0]	I/O, CMOS	N/A	ULPI bi-directional data bus. DATA[0] is the LSB.
B5	NXT	Output, CMOS	High	The PHY asserts NXT to throttle the data. When the Link is sending data to the PHY, NXT indicates when the current byte has been accepted by the PHY. The Link places the next byte on the data bus in the following clock cycle.

Datasheet

Table 2.1 USB332x Pin Description (continued)

BALL	NAME	DIRECTION/ TYPE	ACTIVE LEVEL	DESCRIPTION
A4	DIR	Output, CMOS	N/A	Controls the direction of the data bus. When the PHY has data to transfer to the Link, it drives DIR high to take ownership of the bus. When the PHY has no data to transfer it drives DIR low and monitors the bus for commands from the Link.
A3	STP	Input, CMOS	High	The Link asserts STP for one clock cycle to stop the data stream currently on the bus. If the Link is sending data to the PHY, STP indicates the last byte of data was on the bus in the previous cycle.
B3	VDD18	Power	N/A	External 1.8V Supply input pin. This pad needs to be bypassed with a 0.1uF capacitor to ground, placed as close as possible to the USB332x.
B2	RESETB	Input, CMOS,	Low	When low, the part is suspended with all ULPI outputs tri-stated. When high, the USB332x will operate as a normal ULPI device, as described in Section 5.5.2 . The state of this pin may be changed asynchronously to the clock signals. When asserted for a minimum of 1 microsecond and then de-asserted, the ULPI registers are reset to their default state and all internal state machines are reset.
A2	REFCLK	Input, CMOS	N/A	ULPI Clock Out Mode: Model-specific reference clock. See Order Numbers on page 2. ULPI Clock In Mode: 60MHz ULPI clock input.
A1	RBIAS	Analog, CMOS	N/A	Bias Resistor pin. This pin requires an 8.06k Ω ($\pm 1\%$) resistor to ground, placed as close as possible to the USB332x. Nominal voltage during ULPI operation is 0.8V.
C3	GND	Ground	N/A	Ground.

Chapter 3 Limiting Values

3.1 Absolute Maximum Ratings

Table 3.1 Absolute Maximum Ratings

PARAMETER	SYMBOL	CONDITIONS	MIN	TYP	MAX	UNITS
VBUS, VBAT, ID, DP, DM, SPK_L, and SPK_R voltage to GND	V_{MAX_5V}	Voltage measured at pin. VBUS tolerant to 30V with external R_{VBUS} .	-0.5		+6.0	V
Maximum VDD18 voltage to Ground	V_{MAX_18V}		-0.5		2.5	V
Maximum VDD33 voltage to Ground	V_{MAX_33V}		-0.5		4.0	V
Maximum I/O voltage to Ground	V_{MAX_IN}		-0.5		$V_{DD18} + 0.7$	V
Operating Temperature	T_{MAX_OP}		-40		85	C
Storage Temperature	T_{MAX_STG}		-55		150	C

Note: Stresses beyond those listed under “Absolute Maximum Ratings” may cause permanent damage to the device. Exposure to absolute maximum rating conditions for extended periods may affect device reliability.

3.2 Recommended Operating Conditions

Table 3.2 Recommended Operating Conditions

PARAMETER	SYMBOL	CONDITIONS	MIN	TYP	MAX	UNITS
VBAT to GND	V_{VBAT}		3.1		5.5	V
VDD33 to GND	V_{DD33}		3.0	3.3	3.6	V
VDD18 to GND	V_{DD18}		1.6	1.8	2.0	V
Input Voltage on Digital Pins (RESETB, STP, DIR, NXT, DATA[7:0])	V_I		0.0		V_{DD18}	V
Voltage on Analog I/O Pins (DP, DM, ID, SPK_L, SPK_R)	$V_{I(I/O)}$		0.0		V_{DD33}	V
VBUS to GND	V_{VMAX}		0.0		5.5	
Ambient Temperature	T_A		-40		85	C

Chapter 4 Electrical Characteristics

The following conditions are assumed unless otherwise specified:

$$V_{VBAT} = 3.1 \text{ to } 5.5\text{V}; V_{DD18} = 1.6 \text{ to } 2.0\text{V}; V_{SS} = 0\text{V}; T_A = -40\text{C to } +85\text{C}$$

The current for 3.3V circuits is sourced at the VBAT pin, except when using an external 3.3V supply as shown in [Figure 5.6](#).

4.1 Operating Current

Table 4.1 Operating Current

PARAMETER	SYMBOL	CONDITIONS	MIN	TYP	MAX	UNITS
Synchronous Mode Current (Default Configuration)	$I_{33AVG(SYNC)}$	Start-up sequence defined in Section 5.5.4 has completed.	5	5.7	5.9	mA
	$I_{18AVG(SYNC)}$		19	22.6	27.5	mA
Synchronous Mode Current (HS USB operation)	$I_{33AVG(HS)}$	Active USB Transfer	10	11.5	13.5	mA
	$I_{18AVG(HS)}$		28	33.6	37	mA
Synchronous Mode Current (FS/LS USB operation)	$I_{33AVG(FS)}$	Active USB Transfer	10	10.5	11.3	mA
	$I_{18AVG(FS)}$		23	27.2	29.4	mA
Serial Mode Current (FS/LS USB) Note 4.1	$I_{33AVG(FS_S)}$		5	5.7	5.9	mA
	$I_{18AVG(FS_S)}$		2	2.9	3.9	mA
USB UART Current Note 4.1	$I_{33AVG(UART)}$		5	5.7	5.9	mA
	$I_{18AVG(UART)}$		2	2.9	3.9	mA
USB Audio Mode	$I_{33AVG(AUDIO)}$	$V_{VBAT} = 4.2\text{V}$ $V_{DD18} = 1.8\text{V}$	17	22	32.3	uA
	$I_{18AVG(AUDIO)}$		30	36.3	60	uA
Low Power Mode Note 4.2	$I_{DD33(LPM)}$	$V_{VBAT} = 4.2\text{V}$ $V_{DD18} = 1.8\text{V}$	17	22.1	34	uA
	$I_{DD18(LPM)}$			1.2	32	uA
Standby Mode	$I_{DD33(RSTB)}$	RESETB = 0 $V_{VBAT} = 4.2\text{V}$ $V_{DD18} = 1.8\text{V}$	17	20.8	34	uA
	$I_{DD18(RSTB)}$			0.9	32	uA

Note 4.1 *ClockSuspendM* bit = 0.

Note 4.2 SessEnd, VbusVId, and IdFloat comparators disabled. STP Interface protection disabled.

4.2 Clock Specifications

The model number for each frequency of REFCLK is provided in [Order Numbers](#) on page 2.

Table 4.2 ULPI Clock Specifications

PARAMETER	SYMBOL	CONDITIONS	MIN	TYP	MAX	UNITS
Suspend Recovery Time Note 4.3	T _{START}	26MHz REFCLK		1.13	2.28	ms
		12MHz REFCLK		2.24	3.49	ms
		52MHz REFCLK		0.52	1.77	ms
		24MHz REFCLK		1.12	2.37	ms
		19.2MHz REFCLK		1.40	2.65	ms
		27MHz REFCLK		1.10	2.25	ms
		38.4MHz REFCLK		0.70	1.95	ms
		13MHz REFCLK		2.07	3.32	ms
PHY Preparation Time	T _{PREP}	60MHz REFCLK ULPI Clock In Mode	0.4	0.45	0.5	ms
CLKOUT Duty Cycle	DC _{CLKOUT}	ULPI Clock In Mode	45		55	%
REFCLK Duty Cycle	DC _{REFCLK}		20		80	%
REFCLK Frequency Accuracy	F _{REFCLK}		-500		+500	PPM

Note 4.3 The Suspend Recovery Time is measured from the start of the REFCLK to when the USB332x de-asserts **DIR**.

Note: The USB332x uses the *AutoResume* feature, [Section 6.2.4.4](#), to allow a host start-up time of less than 1ms

4.3 ULPI Interface Timing

Table 4.3 ULPI Interface Timing

PARAMETER	SYMBOL	CONDITIONS	MIN	MAX	UNITS
60MHz ULPI Output Clock Note 4.4					
Setup time (STP, data in)	T _{SC} , T _{SD}	Model-specific REFCLK	5.0		ns
Hold time (STP, data in)	T _{HC} , T _{HD}	Model-specific REFCLK	0.0		ns
Output delay (control out, 8-bit data out)	T _{DC} , T _{DD}	Model-specific REFCLK	1.1	3.5	ns
60MHz ULPI Input Clock					
Setup time (STP, data in)	T _{SC} , T _{SD}	60MHz REFCLK	1.5		ns
Hold time (STP, data in)	T _{HC} , T _{HD}	60MHz REFCLK	-0.5		ns
Output delay (control out, 8-bit data out)	T _{DC} , T _{DD}	60MHz REFCLK	1.5	6.0	ns

Note: V_{DD18} = 1.6 to 2.0V; V_{SS} = 0V; T_A = -40C to 85C, C_{load} = 10pF

Note 4.4 REFCLK does not need to be aligned in any way to the ULPI signals.

Datasheet

4.4 Digital IO Pins

Table 4.4 Digital IO Characteristics: RESETB, STP, DIR, NXT, DATA[7:0], and REFCLK Pins

PARAMETER	SYMBOL	CONDITIONS	MIN	TYP	MAX	UNITS
Low-Level Input Voltage	V_{IL}		V_{SS}		0.4 * V_{DD18}	V
High-Level Input Voltage	V_{IH}		0.68 * V_{DD18}		V_{DD18}	V
High-Level Input Voltage REFCLK only	V_{IH}		0.68 * V_{DD18}		V_{DD33}	V
Low-Level Output Voltage	V_{OL}	$I_{OL} = 8\text{mA}$			0.4	V
High-Level Output Voltage	V_{OH}	$I_{OH} = -8\text{mA}$	V_{DD18} - 0.4			V
Input Leakage Current	I_{LI}				±10	uA
Pin Capacitance	C_{pin}				4	pF
STP pull-up resistance	R_{STP}	<i>InterfaceProtectDisable = 0</i>	55	67	77	kΩ
DATA[7:0] pull-dn resistance	R_{DATA_PD}	<i>ULPI Synchronous Mode</i>	55	67	77	kΩ
CLKOUT External Drive	V_{IH_ED}	At start-up or following reset			0.4 * V_{DD18}	V

4.5 DC Characteristics: Analog I/O Pins

Table 4.5 DC Characteristics: Analog I/O Pins (DP/DM)

PARAMETER	SYMBOL	CONDITIONS	MIN	TYP	MAX	UNITS
LS/FS FUNCTIONALITY						
Input levels						
Differential Receiver Input Sensitivity	V_{DIFS}	$ V(DP) - V(DM) $	0.2			V
Differential Receiver Common-Mode Voltage	V_{CMFS}		0.8		2.5	V
Single-Ended Receiver Low Level Input Voltage	V_{ILSE}	Note 4.6			0.8	V
Single-Ended Receiver High Level Input Voltage	V_{IHSE}	Note 4.6	2.0			V
Single-Ended Receiver Hysteresis	V_{HYSSE}		0.050		0.150	V
Output Levels						
Low Level Output Voltage	V_{FSOL}	Pull-up resistor on DP; $R_L = 1.5\text{k}\Omega$ to V_{DD33}			0.3	V
High Level Output Voltage	V_{FSOH}	Pull-down resistor on DP, DM; Note 4.6 $R_L = 15\text{k}\Omega$ to GND	2.8		3.6	V

Table 4.5 DC Characteristics: Analog I/O Pins (DP/DM) (continued)

PARAMETER	SYMBOL	CONDITIONS	MIN	TYP	MAX	UNITS
Termination						
Driver Output Impedance for HS and FS	Z_{HSDRV}	Steady state drive	40.5	45	49.5	Ω
Input Impedance	Z_{INP}	RX, RPU, RPD disabled	1.1			M Ω
Pull-up Resistor Impedance	R_{PU}	Bus Idle, Note 4.5	0.900	1.24	1.575	k Ω
Pull-up Resistor Impedance	R_{PU}	Device Receiving, Note 4.5	1.425	2.26	3.09	k Ω
Pull-dn Resistor Impedance	R_{PD}	Note 4.5	14.25	16.9	20	k Ω
Weak Pull-up Resistor Impedance	R_{CD}	Configured by bits 4 and 5 in USB IO & Power Management register.	128	170	212	k Ω
HS FUNCTIONALITY						
Input levels						
HS Differential Input Sensitivity	V_{DIHS}	V(DP) - V(DM)	100			mV
HS Data Signaling Common Mode Voltage Range	V_{CMHS}		-50		500	mV
High-Speed Squelch Detection Threshold (Differential Signal Amplitude)	V_{HSSQ}	Note 4.7	100		150	mV
Output Levels						
Hi-Speed Low Level Output Voltage (DP/DM referenced to GND)	V_{HSOL}	45 Ω load	-10		10	mV
Hi-Speed High Level Output Voltage (DP/DM referenced to GND)	V_{HSOH}	45 Ω load	360		440	mV
Hi-Speed IDLE Level Output Voltage (DP/DM referenced to GND)	V_{OLHS}	45 Ω load	-10		10	mV
Chirp-J Output Voltage (Differential)	V_{CHIRPJ}	HS termination resistor disabled, pull-up resistor connected. 45 Ω load.	700		1100	mV
Chirp-K Output Voltage (Differential)	V_{CHIRPK}	HS termination resistor disabled, pull-up resistor connected. 45 Ω load.	-900		-500	mV
Leakage Current						
OFF-State Leakage Current	I_{LZ}				± 10	μA
Port Capacitance						
Transceiver Input Capacitance	C_{IN}	Pin to GND		5	10	pF

Note 4.5 The resistor value follows the 27% Resistor ECN published by the USB-IF.

Datasheet

Note 4.6 The values shown are valid when the *USB RegOutput* bits in the [USB IO & Power Management](#) register are set to the default value.

Note 4.7 An automatic waiver up to 200mV is granted to accommodate system-level elements such as measurement/test fixtures, captive cables, EMI components, and ESD suppression.

4.6 Dynamic Characteristics: Analog I/O Pins

Table 4.6 Dynamic Characteristics: Analog I/O Pins (DP/DM)

PARAMETER	SYMBOL	CONDITIONS	MIN	TYP	MAX	UNITS
FS Output Driver Timing						
FS Rise Time	T_{FR}	$C_L = 50\text{pF}$; 10 to 90% of $ V_{OH} - V_{OL} $	4		20	ns
FS Fall Time	T_{FF}	$C_L = 50\text{pF}$; 10 to 90% of $ V_{OH} - V_{OL} $	4		20	ns
Output Signal Crossover Voltage	V_{CRS}	Excluding the first transition from IDLE state	1.3		2.0	V
Differential Rise/Fall Time Matching	T_{FRFM}	Excluding the first transition from IDLE state	90		111.1	%
LS Output Driver Timing						
LS Rise Time	T_{LR}	$C_L = 50\text{-}600\text{pF}$; 10 to 90% of $ V_{OH} - V_{OL} $	75		300	ns
LS Fall Time	T_{LF}	$C_L = 50\text{-}600\text{pF}$; 10 to 90% of $ V_{OH} - V_{OL} $	75		300	ns
Differential Rise/Fall Time Matching	T_{LRFM}	Excluding the first transition from IDLE state	80		125	%
HS Output Driver Timing						
Differential Rise Time	T_{HSR}		500			ps
Differential Fall Time	T_{HSF}		500			ps
Driver Waveform Requirements		Eye pattern of Template 1 in USB 2.0 specification				
Hi-Speed Mode Timing						
Receiver Waveform Requirements		Eye pattern of Template 4 in USB 2.0 specification				
Data Source Jitter and Receiver Jitter Tolerance		Eye pattern of Template 4 in USB 2.0 specification				

4.7 OTG Electrical Characteristics

Table 4.7 OTG Electrical Characteristics

PARAMETER	SYMBOL	CONDITIONS	MIN	TYP	MAX	UNITS
SessEnd trip point	$V_{SessEnd}$		0.2	0.5	0.8	V
SessVld trip point	$V_{SessVld}$		0.8	1.4	2.0	V
VbusVld trip point	$V_{VbusVld}$		4.4	4.58	4.75	V
A-Device Impedance	R_{IdGnd}	Maximum A device Impedance to ground on ID pin			100	k Ω
ID Float trip point	$V_{IdFloat}$		1.9	2.2	2.5	V
VBUS Pull-Up	R_{VPU}	VBUS to VDD33 Note 4.8 (ChargeVbus = 1)	1.29	1.34	1.45	k Ω
VBUS Pull-down	R_{VPD}	VBUS to GND Note 4.8 (DisChargeVbus = 1)	1.55	1.7	1.85	k Ω
VBUS Impedance	R_{VB}	VBUS to GND	40	75	100	k Ω
ID pull-up resistance	R_{ID}	$IdPullup = 1$	80	100	120	k Ω
ID weak pull-up resistance	R_{IDW}	$IdPullup = 0$	1			M Ω
ID pull-dn resistance	R_{IDPD}	$IdGndDrv = 1$			1000	Ω

Note 4.8 The R_{VPD} and R_{VPU} values include the required 1k Ω external R_{VBUS} resistor.

4.8 USB Audio Switch Characteristics

Table 4.8 USB Audio Switch Characteristics

PARAMETER	SYMBOL	CONDITIONS	MIN	TYP	MAX	UNITS
Minimum "ON" Resistance	R_{ON_Min}	$0 < V_{switch} < V_{DD33}$	2.7	5	5.8	Ω
Maximum "ON" Resistance	R_{ON_Max}	$0 < V_{switch} < V_{DD33}$	4.5	7	10	Ω
Minimum "OFF" Resistance	R_{OFF_Min}	$0 < V_{switch} < V_{DD33}$	1			M Ω

4.9 Regulator Output Voltages and Capacitor Requirement

Table 4.9 Regulator Output Voltages and Capacitor Requirement

PARAMETER	SYMBOL	CONDITIONS	MIN	TYP	MAX	UNITS
Regulator Output Voltage	V_{DD33}	$6V > V_{BAT} > 3.1V$	3.0	3.3	3.6	V
Regulator Output Voltage	V_{DD33}	USB UART Mode & <i>UART RegOutput[1:0] = 01</i> $6V > V_{BAT} > 3.1V$	2.7	3.0	3.3	V
Regulator Output Voltage	V_{DD33}	USB UART Mode & <i>UART RegOutput[1:0] = 10</i> $6V > V_{BAT} > 3.1V$	2.47	2.75	3.03	V
Regulator Output Voltage	V_{DD33}	USB UART Mode & <i>UART RegOutput[1:0] = 11</i> $6V > V_{BAT} > 3.1V$	2.25	2.5	2.75	V
Regulator Bypass Capacitor	C_{OUT}		2.2			μF
Bypass Capacitor ESR	C_{ESR}				1	Ω

Table 4.10 ESD and LATCH-UP Performance

PARAMETER	CONDITIONS	MIN	TYP	MAX	UNITS	COMMENTS
ESD PERFORMANCE						
Note 4.9	Human Body Model			± 8	kV	Device
System	EN/IEC 61000-4-2 Contact Discharge			± 8	kV	3rd party system test
System	EN/IEC 61000-4-2 Air-gap Discharge			± 15	kV	3rd party system test
LATCH-UP PERFORMANCE						
All Pins	EIA/JESD 78, Class II		150		mA	

Note 4.9 REFCLK, SPK_L and SPK_R pins: $\pm 5kV$ Human Body Model

Chapter 5 Architecture Overview

The USB332x consists of the blocks shown in the diagram below. All pull-up resistors shown in this diagram are connected internally to the **VDD33** pin.

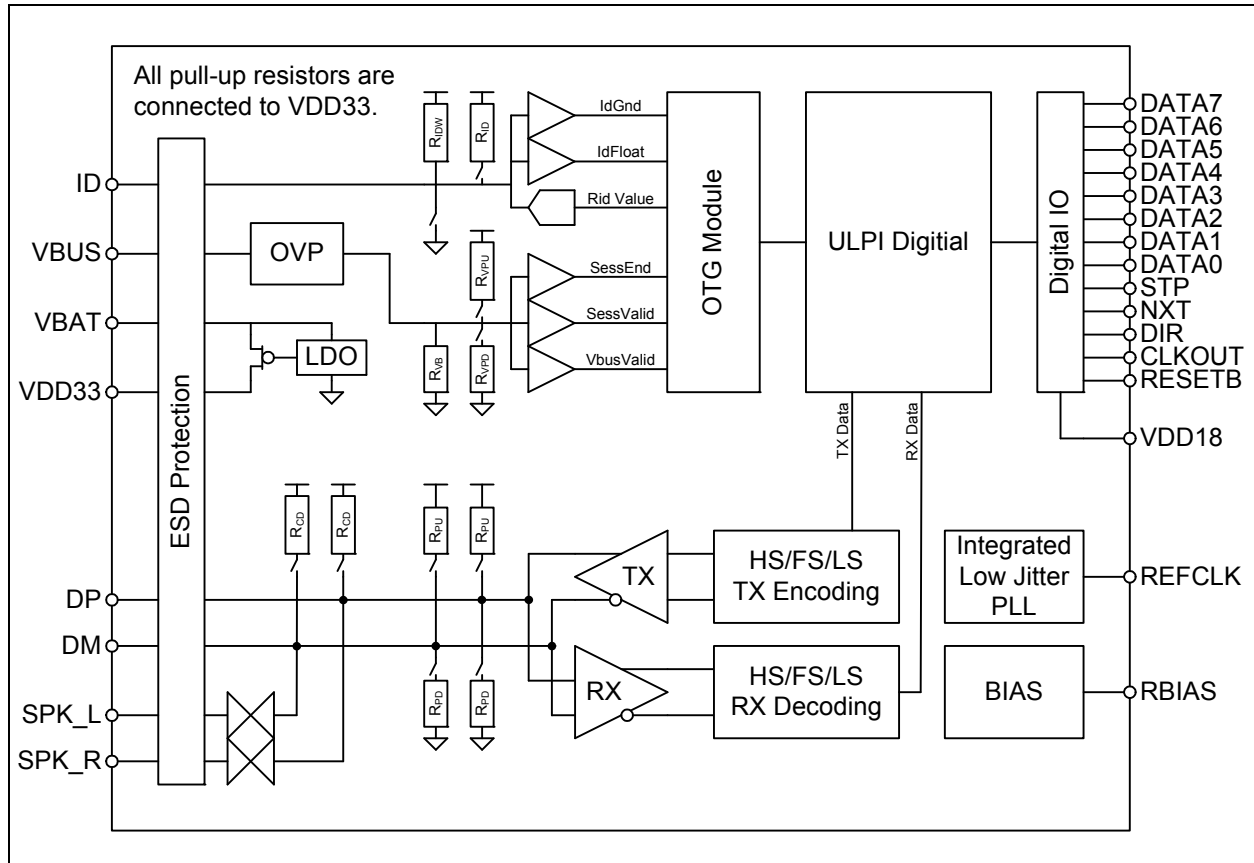

Figure 5.1 USB332x System Diagram

5.1 ULPI Digital Operation and Interface

This section of the USB332x is covered in detail in [Chapter 6, ULPI Operation](#).

5.2 USB 2.0 Hi-Speed Transceiver

The blocks in the lower left-hand corner of [Figure 5.1](#) interface to the DP/DM pins.

5.2.1 USB Transceiver

The USB332x transceiver includes the receivers and transmitters required to be compliant to the Universal Serial Bus Specification Rev 2.0. The DP/DM signals in the USB cable connect directly to the receivers and transmitters.

The RX block consists of separate differential receivers for HS and FS/LS mode. Depending on the mode, the selected receiver provides the serial data stream through the multiplexer to the RX Logic block. For HS mode support, the HS RX block contains a squelch circuit to insure that noise is not

Datasheet

interpreted as data. The RX block also includes a single-ended receiver on each of the data lines to determine the correct FS linestate.

Data from the TX Logic block is encoded, bit stuffed, serialized and transmitted onto the USB cable by the TX block. Separate differential FS/LS and HS transmitters are included to support all modes.

The USB332x TX block meets the HS signalling level requirements in the USB 2.0 Specification when the PCB traces from the **DP** and **DM** pins to the USB connector have very little loss. In some systems, it may be desirable to compensate for loss by adjusting the HS transmitter amplitude. The *Boost* bits in the **HS TX Boost** register may be configured to adjust the HS transmitter amplitude at the **DP** and **DM** pins.

5.2.2 Termination Resistors

The USB332x transceiver fully integrates all of the USB termination resistors on both **DP** and **DM**. This includes 1.5k Ω pull-up resistors, 15k Ω pull-down resistors and the 45 Ω high speed termination resistors. These resistors require no tuning or trimming by the Link. The state of the resistors is determined by the operating mode of the PHY when operating in synchronous mode.

The *XcvrSelect*[1:0], *TermSelect* and *OpMode*[1:0] bits in the **Function Control** register, and the *DpPulldown* and *DmPulldown* bits in the **OTG Control** register control the configuration. The possible valid resistor combinations are shown in **Table 5.1**, and operation is guaranteed in only the configurations shown. If a ULPI Register Setting is configured that does not match a setting in the table, the transceiver operation is not guaranteed and the settings in the last row of **Table 5.1** will be used.

- RPU_DP_EN activates the 1.5k Ω DP pull-up resistor
- RPU_DM_EN activates the 1.5k Ω DM pull-up resistor
- RPD_DP_EN activates the 15k Ω DP pull-down resistor
- RPD_DM_EN activates the 15k Ω DM pull-down resistor
- HSTERM_EN activates the 45 Ω DP and DM high speed termination resistors

The USB332x also includes two **DP** and **DM** pull-up resistors described in **Section 5.8**.

Table 5.1 DP/DM Termination vs. Signaling Mode

SIGNALING MODE	ULPI REGISTER SETTINGS					USB332X TERMINATION RESISTOR SETTINGS				
	XCVRSELECT[1:0]	TERMSELECT	OPMODE[1:0]	DPPULLDOWN	DMPULLDOWN	RPU_DP_EN	RPU_DM_EN	RPD_DP_EN	RPD_DM_EN	HSTERM_EN
General Settings										
Tri-State Drivers	XXb	Xb	01b	Xb	Xb	0b	0b	0b	0b	0b
Power-up or VBUS < V _{SESEND}	01b	0b	00b	1b	1b	0b	0b	1b	1b	0b
Host Settings										
Host Chirp	00b	0b	10b	1b	1b	0b	0b	1b	1b	1b
Host Hi-Speed	00b	0b	00b	1b	1b	0b	0b	1b	1b	1b
Host Full Speed	X1b	1b	00b	1b	1b	0b	0b	1b	1b	0b

Table 5.1 DP/DM Termination vs. Signaling Mode (continued)

SIGNALING MODE	ULPI REGISTER SETTINGS					USB332X TERMINATION RESISTOR SETTINGS				
	XCVRSELECT[1:0]	TERMSELECT	OPMODE[1:0]	DPPULLDOWN	DMPULLDOWN	RPU_DP_EN	RPU_DM_EN	RPD_DP_EN	RPD_DM_EN	HSTERM_EN
Host HS/FS Suspend	01b	1b	00b	1b	1b	0b	0b	1b	1b	0b
Host HS/FS Resume	01b	1b	10b	1b	1b	0b	0b	1b	1b	0b
Host low Speed	10b	1b	00b	1b	1b	0b	0b	1b	1b	0b
Host LS Suspend	10b	1b	00b	1b	1b	0b	0b	1b	1b	0b
Host LS Resume	10b	1b	10b	1b	1b	0b	0b	1b	1b	0b
Host Test J/Test_K	00b	0b	10b	1b	1b	0b	0b	1b	1b	1b
Peripheral Settings										
Peripheral Chirp	00b	1b	10b	0b	0b	1b	0b	0b	0b	0b
Peripheral HS	00b	0b	00b	0b	0b	0b	0b	0b	0b	1b
Peripheral FS	01b	1b	00b	0b	0b	1b	0b	0b	0b	0b
Peripheral HS/FS Suspend	01b	1b	00b	0b	0b	1b	0b	0b	0b	0b
Peripheral HS/FS Resume	01b	1b	10b	0b	0b	1b	0b	0b	0b	0b
Peripheral LS	10b	1b	00b	0b	0b	0b	1b	0b	0b	0b
Peripheral LS Suspend	10b	1b	00b	0b	0b	0b	1b	0b	0b	0b
Peripheral LS Resume	10b	1b	10b	0b	0b	0b	1b	0b	0b	0b
Peripheral Test J/Test K	00b	0b	10b	0b	0b	0b	0b	0b	0b	1b
OTG device, Peripheral Chirp	00b	1b	10b	0b	1b	1b	0b	0b	1b	0b
OTG device, Peripheral HS	00b	0b	00b	0b	1b	0b	0b	0b	1b	1b
OTG device, Peripheral FS	01b	1b	00b	0b	1b	1b	0b	0b	1b	0b
OTG device, Peripheral HS/FS Suspend	01b	1b	00b	0b	1b	1b	0b	0b	1b	0b
OTG device, Peripheral HS/FS Resume	01b	1b	10b	0b	1b	1b	0b	0b	1b	0b
OTG device, Peripheral Test J/Test K	00b	0b	10b	0b	1b	0b	0b	0b	1b	1b
Any combination not defined above Note 5.1						0b	0b	0b	0b	0b

Note: This is the same as Table 40, Section 4.4 of the ULPI 1.1 specification.

Note: USB332x does not support operation as an upstream hub port. See [Section 6.2.4.3, "UTMI+ Level 3"](#).

Note 5.1 The transceiver operation is not guaranteed in a combination that is not defined.

Datasheet

The USB332x uses the 27% resistor ECN resistor tolerances. The resistor values are shown in [Table 4.5](#).

5.3 Bias Generator

This block consists of an internal bandgap reference circuit used for generating the driver current and the biasing of the analog circuits. This block requires an external $8.06\text{K}\Omega$, 1% tolerance, reference resistor connected from **RBIAS** to ground. This resistor should be placed as close as possible to the USB332x to minimize the trace length. The nominal voltage at **RBIAS** is $0.8\text{V} \pm 10\%$ and therefore the resistor will dissipate approximately $80\mu\text{W}$ of power.

5.4 Integrated Low Jitter PLL

The USB332x uses an integrated low jitter phase locked loop (PLL) to provide a clean 480MHz clock required for HS USB signal quality. This clock is used by the PHY during both transmit and receive. The USB332x PLL requires an accurate frequency reference to be driven on the **REFCLK** pin.

The system must not drive voltage on the CLKOUT pin following POR or hardware reset that exceeds the value of V_{IH_ED} provided in [Table 4.4](#).

5.4.1 REFCLK Frequency Selection

The USB332x is designed to operate in one of two available modes. In the first mode, a 60MHz ULPI clock is driven on the **REFCLK** pin. In the second mode, the unique reference clock frequency shown in [Order Numbers](#) on page 2 is driven on the **REFCLK** pin. The the Link is driving the ULPI clock in the first mode, and this is referred to as **ULPI Clock In Mode**. In the second mode, the USB332x generates the ULPI clock, and this is referred to as **ULPI Clock Out Mode**.

During start-up, the USB332x monitors the **CLKOUT** pin. If a connection to **VDD18** is detected, the USB332x is configured for a 60MHz ULPI reference clock driven into the **REFCLK** pin. [Section 5.4.1.1](#) and [Section 5.4.1.2](#) describe how to configure the USB332x for either ULPI Clock In Mode or ULPI Clock Out Mode.

5.4.1.1 ULPI Clock In Mode (60MHz REFCLK Mode)

When using ULPI Clock In Mode, the Link must supply the 60MHz ULPI clock to the USB332x. In this mode the 60MHz ULPI Clock is connected to the **REFCLK** pin, and the **CLKOUT** pin is tied high to **VDD18**. An example of ULPI Clock In Mode is shown in [Figure 8.2](#). After the PLL has locked to the correct frequency, the USB332x will de-assert **DIR** and the Link can begin using the ULPI interface. The USB332x is guaranteed to start the clock within the time specified in [Table 4.2](#). For Host applications, the ULPI *AutoResume* bit should be enabled. This is described in [Section 6.2.4.4](#).

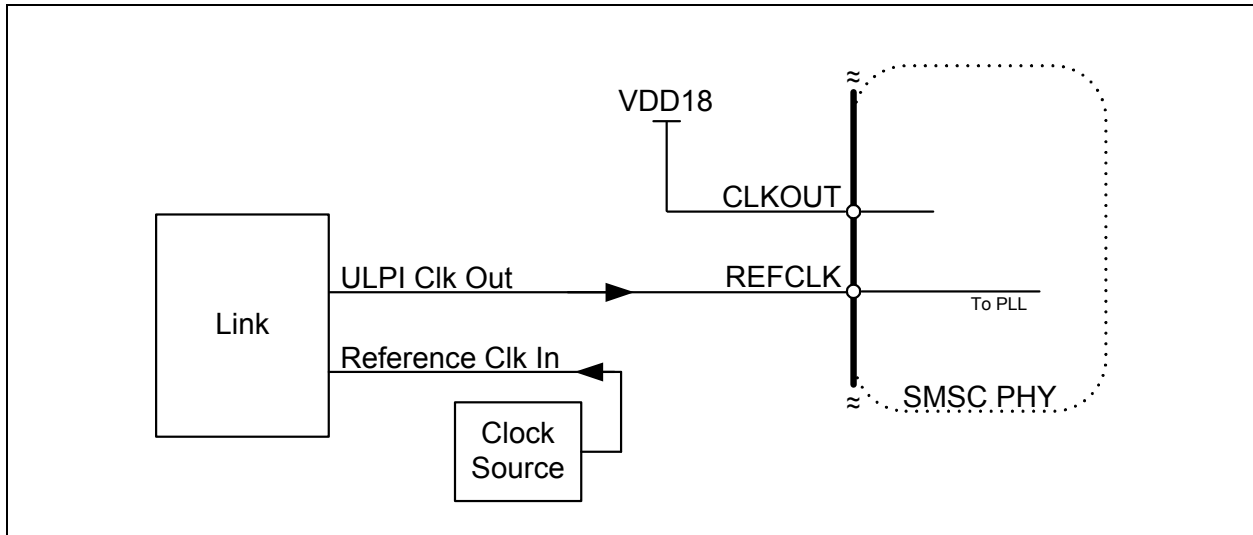

Figure 5.2 Configuring the USB332X for ULPI Clock In Mode (60 MHz)

5.4.1.2 ULPI Clock Out Mode

When using ULPI Clock Out Mode, the USB332x generates the 60MHz ULPI clock used by the Link. In this mode, the **REFCLK** pin must be driven with the model-specific frequency, and the **CLKOUT** pin sources the 60MHz ULPI clock to the Link. An example of ULPI Clock Out Mode is shown in [Figure 8.1](#)

After the PLL has locked to the correct frequency, the USB332x generates the 60MHz ULPI clock on the **CLKOUT** pin, and de-asserts **DIR** to indicate that the PLL is locked. The USB332x is guaranteed to start the clock within the time specified in [Table 4.2](#), and it will be accurate to within $\pm 500\text{ppm}$. For Host applications the ULPI *AutoResume* bit should be enabled. This is described in [Section 6.2.4.4](#).

When using ULPI Clock Out Mode, the edges of the reference clock do not need to be aligned in any way to the ULPI interface signals. There is no need to align the phase of the **REFCLK** and the **CLKOUT**.

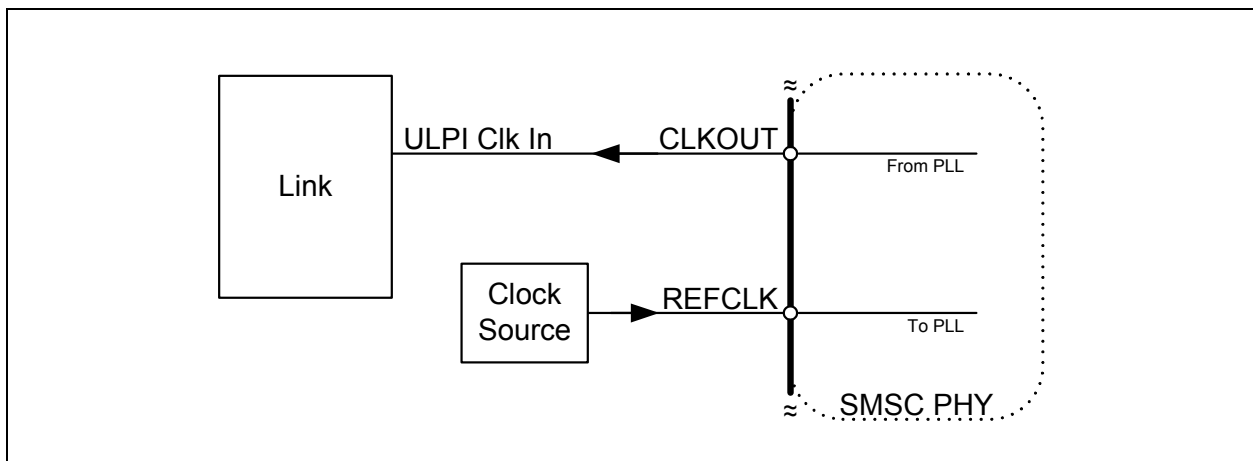

Figure 5.3 Configuring the USB332X for ULPI Clock Out Mode

5.4.2 REFCLK Amplitude

The reference clock is connected to the **REFCLK** pin as shown in the application diagrams, [Figure 8.1](#) and [Figure 8.2](#). The **REFCLK** pin is designed to be driven with a square wave from 0V to V_{DD18} , but

Datasheet

can be driven with a square wave from 0V to as high as 3.6V. The USB332x uses only the positive edge of the **REFCLK**.

If a digital reference is not available, the **REFCLK** pin can be driven by an analog sine wave that is AC coupled into the **REFCLK** pin. If using an analog clock the DC bias should be set at the mid-point of the **VDD18** supply using a bias circuit as shown in Figure 5.4. The amplitude must be greater than 300mV peak to peak. The component values provided in Figure 5.4 are for example only. The actual values should be selected to satisfy system requirements.

The **REFCLK** amplitude must comply with the signal amplitudes shown in Table 4.4 and the duty cycle in Table 4.2.

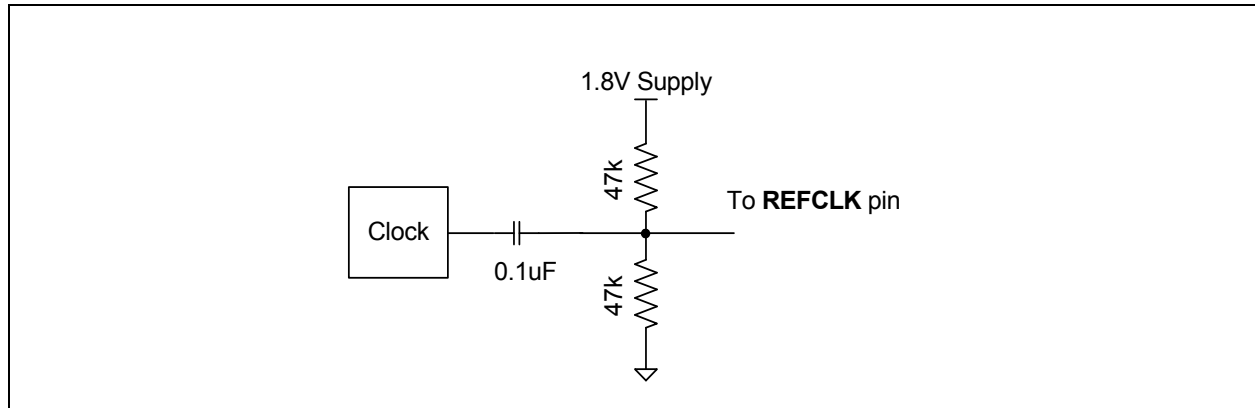

Figure 5.4 Example of circuit used to shift a reference clock common-mode voltage level.

5.4.3 REFCLK Jitter

The USB332x is tolerant to jitter on the reference clock. The REFCLK jitter should be limited to a peak to peak jitter of less than 1nS over a 10uS time interval. If this level of jitter is exceeded when configured for either ULPI Clock In Mode or ULPI Clock Out Mode, the USB332x Hi-Speed eye diagram may be degraded.

The frequency accuracy of the REFCLK must meet the +/- 500ppm requirement as shown in Table 4.2.

5.4.4 REFCLK Enable/Disable

The **REFCLK** should be enabled when the **RESETB** pin is brought high. The ULPI interface will start running after the time specified in Table 4.2. If the REFCLK enable is delayed relative to the RESETB pin, the ULPI interface will start operation delayed by the same amount. The REFCLK can be run at anytime the **RESETB** pin is low without causing the USB332x to start-up or draw current.

When the USB332x is placed in Low Power Mode or CarKit Mode, the REFCLK can be stopped after the final ULPI register write is complete. The **STP** pin is asserted to bring the USB332x out of Low Power Mode. The **REFCLK** should be started at the same time **STP** is asserted to minimize the USB332x start-up time.

If the **REFCLK** is stopped while **CLKOUT** is running, the PLL will come out of lock and the frequency of the **CLKOUT** signal will decrease to the minimum allowed by the PLL design. If the **REFCLK** is stopped during a USB session, the session may drop.

5.5 Internal Regulators and POR

The USB332x includes integrated power management functions, including a Low-Dropout regulator that can be used to generate the 3.3V USB supply, and a POR generator described in [Section 5.5.2](#).

5.5.1 Integrated Low Dropout Regulator

The USB332x has an integrated linear regulator. Power sourced at the **VBAT** pin is regulated to 3.3V and the regulator output is on the **VDD33** pin. To ensure stability, the regulator requires an external bypass capacitor (C_{OUT}) as specified in [Table 4.9](#) placed as close to the pin as possible.

The USB332x regulator is designed to generate a 3.3 volt supply for the USB332x only. Using the regulator to provide current for other circuits is not recommended and SMSC does not guarantee USB performance or regulator stability.

During USB UART mode the regulator output voltage can be changed to allow the USB332x to work with UARTs operating at different operating voltages. The regulator output is configured to the voltages shown in [Table 4.9](#) with the *UART RegOutput[1:0]* bits in the [USB IO & Power Management](#) register.

The USB332x regulator can be powered in the three methods as shown below.

For USB Peripheral, Host, and OTG operations the regulator can be connected as shown in [Figure 5.5](#) or [Figure 5.6](#) below. For OTG operation, the **VDD33** supply on the USB332x must be powered to detect devices attaching to the USB connector and detect a SRP during an OTG session. When using a battery to supply the USB332x, the battery voltage must be within the range of 3.1V to 5.5V

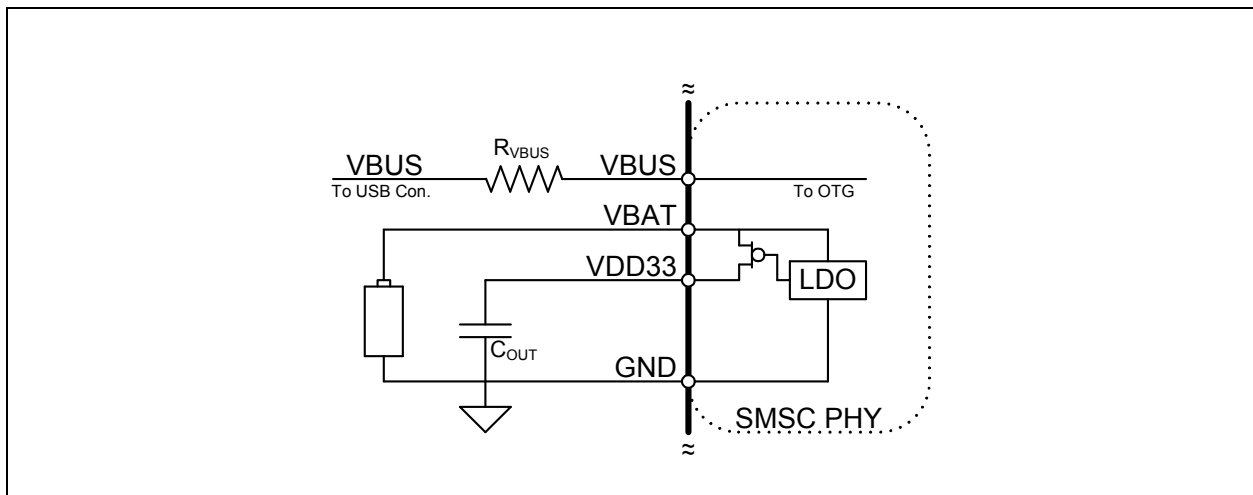

Figure 5.5 Powering the USB332x from a Battery

Datasheet

The USB332x can be powered from an external 3.3V supply as shown below in the [Figure 5.6](#). When using the external supply, both the **VBAT** and **VDD33** pins are connected together. The bypass capacitor, C_{BYP} , should be included when using the external supply.

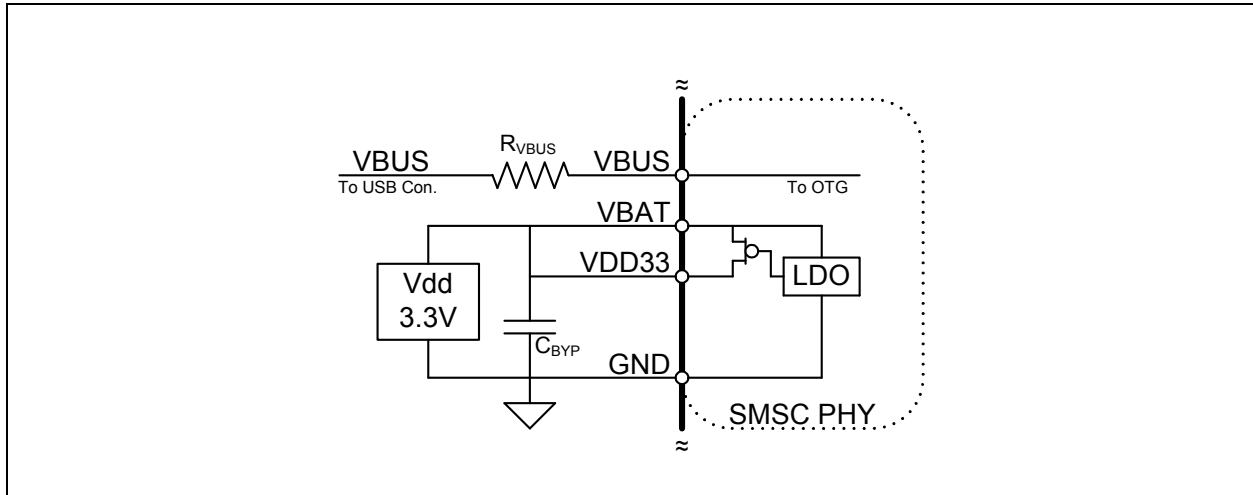

Figure 5.6 Powering the USB332x from a 3.3V Supply

For peripheral only or host only operation, the **VBAT** supply shown below in [Figure 5.7](#) may be connected to the **VBUS** pin of the USB connector for bus powered applications. In this configuration, external overvoltage protection is required to protect the **VBAT** supply from any transient voltage present at the **VBUS** pin of the USB connector.

The **VBAT** input must never be exposed to a voltage that exceeds V_{VBAT} . (See [Table 3.2](#))

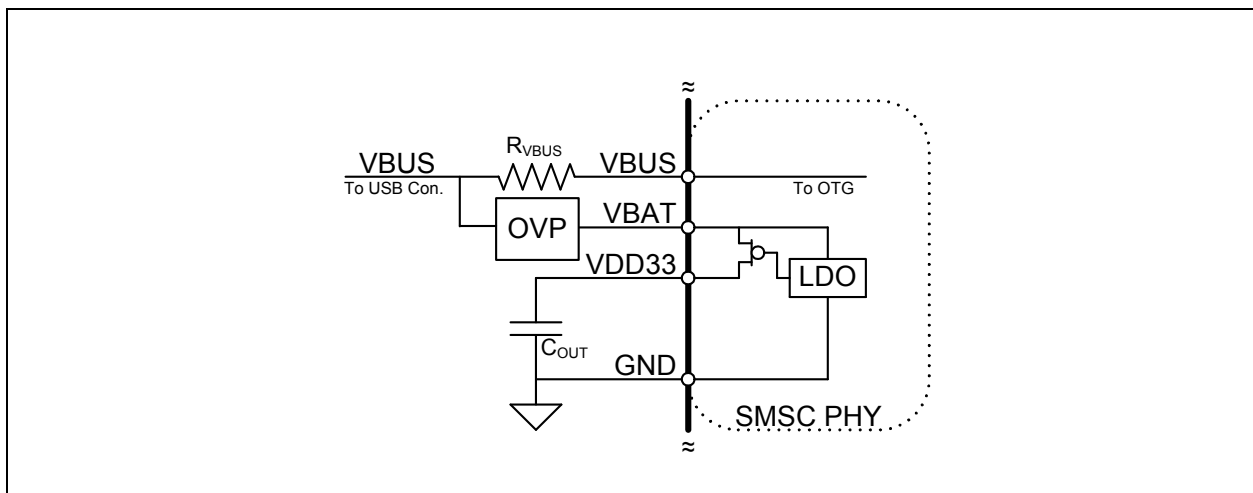

Figure 5.7 Powering the USB332x from VBUS

5.5.2 Power On Reset (POR)

The USB332x provides a POR circuit that generates an internal reset pulse after the **VDD18** supply is stable. After the internal POR goes high and the **RESETB** pin is high, the USB332x will release from reset and begin normal ULPI operation as described in [Section 5.5.4](#).

The ULPI registers will power up in their default state summarized in [Table 7.1](#) when the 1.8V supply is brought up. Cycling the 1.8 volt power supply will reset the ULPI registers to their default states. The **RESETB** pin can also be used to reset the ULPI registers to their default state (and reset all internal state machines) by bringing the pin low for a minimum of 1 microsecond and then high.

The Link is not required to assert the **RESETB** pin. A pull-down resistor is not present on the **RESETB** pin and therefore the Link must drive the **RESETB** pin to the desired state at all times (including system start-up) or connect the **RESETB** pin to **VDD18**.

5.5.3 Recommended Power Supply Sequence

The power supplies can be applied to the USB332x in any order. The order in which the supplies are brought up is not important. For USB operation the USB332x requires the **VBAT**, **VDD33**, and **VDD18** supplies.

When the **VBAT** supply is applied the integrated regulator will automatically start-up and regulate **VBAT** to **VDD33**. If the **VDD33** supply is powered and the **VDD18** supply is not powered, the 3.3V circuits are powered off and the **VDD33** current will be limited to 20uA as shown in [Table 4.1](#), "Operating Current".

The ULPI interface will start operating after the **VDD18** supply is applied and the **RESETB** pin is brought high. The **RESETB** pin must be held low until the VDD18 supply is stable. If the Link is not ready to interface the USB332x, the Link may choose to hold the **RESETB** pin low until it is ready to control the ULPI interface.

Table 5.2 Operating Mode vs. Power Supply Configuration

VDD33	VDD18	RESETB	OPERATING MODES AVAILABLE
0	0	0	Powered Off
0	1	0	RESET Mode.
0	1	1	In this configuration the ULPI interface is available and can be programmed into all operating modes described in Chapter 6 . All USB signals will read 0.
1	0	X	In this mode the ULPI interface is not active and the circuits powered from the VDD33 are turned off and the current will be limited to the RESET Mode current. (Note 5.2)
1	1	0	RESET Mode
1	1	1	Full USB operation as described in Chapter 6 .

Note: Anytime **VBAT** is powered per [Table 3.2](#), the **VDD33** pin will be powered up.

Note 5.2 **VDD18** must be powered to tri-state the ULPI interface in this configuration.

5.5.4 Start-Up

The power on default state of the USB332x is ULPI Synchronous mode. The USB332x requires the following conditions to begin operation: the power supplies must be stable, the **REFCLK** must be

Datasheet

present and the **RESETB** pin must be high. After these conditions are met, the USB332x will begin ULPI operation that is described in [Chapter 6, ULPI Operation](#).

[Figure 5.8](#) below shows a timing diagram to illustrate the start-up of the USB332x. At T0, the supplies are stable and the USB332x is held in reset mode. At T1, the Link drives **RESETB** high after the **REFCLK** has started. The **RESETB** pin may be brought high asynchronously to **REFCLK**. At this point the USB332x will drive idle on the data bus and assert **DIR** until the internal PLL has locked. After the PLL has locked, the USB332x will check that the Link has de-asserted **STP** and at T2 it will de-assert **DIR** and begin ULPI operation.

The ULPI bus will be available as shown in [Figure 5.8](#) in the time defined as T_{START} given in [Table 4.2](#). If the **REFCLK** signal starts after the **RESETB** pin is brought high, then time T0 will begin when **REFCLK** starts. T_{START} also assumes that the Link has de-asserted **STP**. If the Link has held **STP** high the USB332x will hold **DIR** high until **STP** is de-asserted. When the LINK de-asserts STP, it must drive a ULPI IDLE one cycle after **DIR** de-asserts.

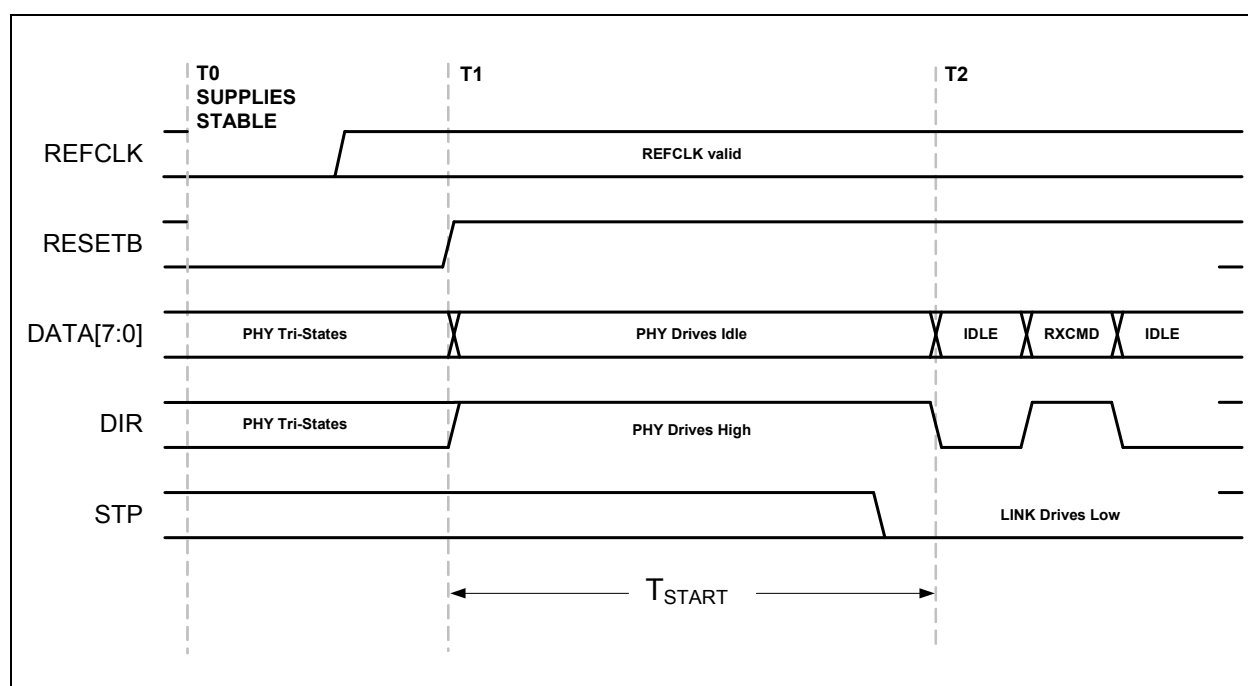

Figure 5.8 ULPI Start-up Timing

5.6 USB On-The-Go (OTG)

The USB332x provides full support for USB OTG protocol. OTG allows the USB332x to be dynamically configured as a host or device depending on the type of cable inserted into the Micro-AB receptacle. When the Micro-A plug of a cable is inserted into the Micro-AB receptacle, the USB device becomes the A-device. When a Micro-B plug is inserted, the device becomes the B-device. The OTG A-device behaves similar to a Host while the B-device behaves similar to a peripheral. The differences are covered in the "On-The-Go Supplement to the USB 2.0 Specification". In applications where only Host or Device is required, the OTG Module is unused.

5.6.1 ID Resistor Detection

The ID pin of the USB connector is monitored by the **ID** pin of the USB332x to detect the attachment of different types of USB devices and cables. For device only applications that do not use the ID signal the **ID** pin should be connected to **VDD33**. The block diagram of the ID detection circuitry is shown in [Figure 5.9](#) and the related parameters are given in [Table 4.7](#).

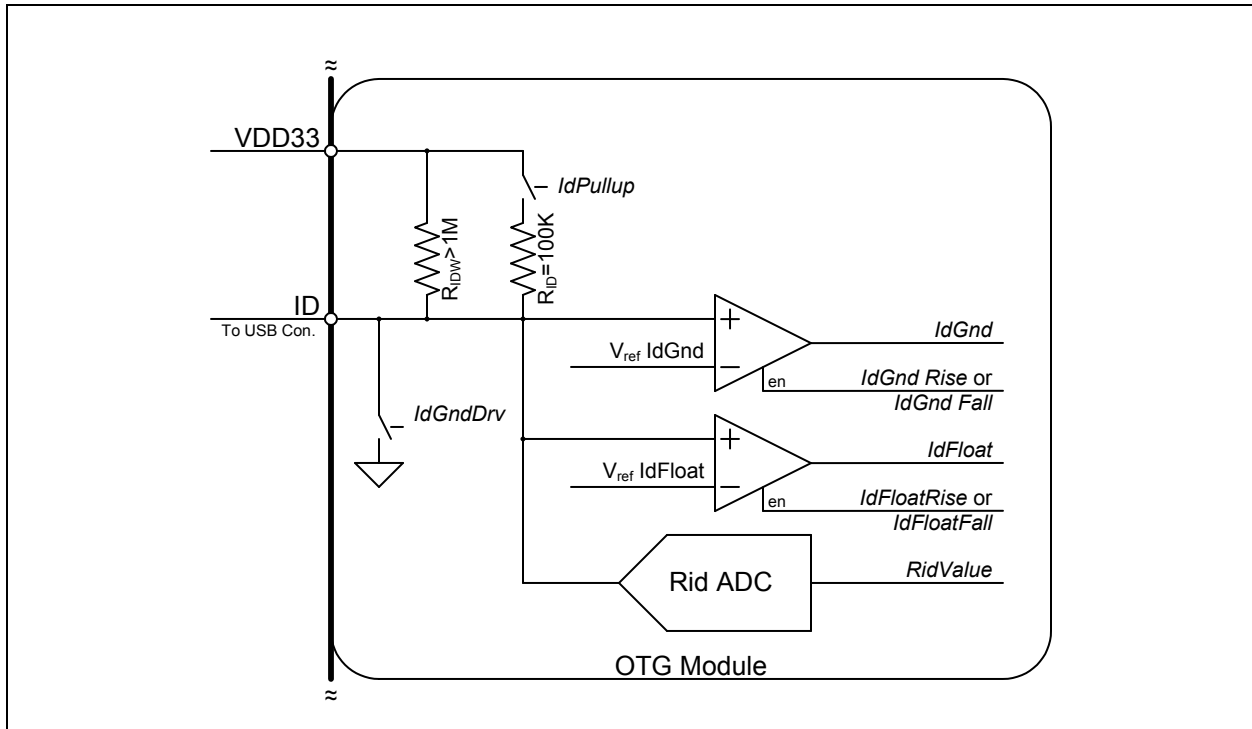

Figure 5.9 USB332x ID Resistor Detection Circuitry

5.6.1.1 USB OTG Operation

The USB332x can detect **ID** grounded and **ID** floating to determine if an A or B cable has been inserted. The A plug will ground the **ID** pin while the B plug will float the **ID** pin. These are the only two valid states allowed in the OTG Protocol.

To monitor the status of the **ID** pin, the Link activates the *IdPullup* bit in the **OTG Control** register, waits 50mS and then reads the status of the *IdGnd* bit in the **USB Interrupt Status** register. If an A cable has been inserted the *IdGnd* bit will read 0. If a B cable is inserted, the **ID** pin is floating and the *IdGnd* bit will read 1.

The USB332x provides an integrated weak pull-up resistor on the **ID** pin, R_{IDW} . This resistor is present to keep the **ID** pin in a known state when the *IdPullup* bit is disabled and the **ID** pin is floated. In addition to keeping the **ID** pin in a known state, it enables the USB332x to generate an interrupt to inform the link when a cable with a resistor to ground has been attached to the **ID** pin. The weak pull-up is small enough that the largest valid Rid resistor pulls the **ID** pin low and causes the *IdGnd* comparator to go low.

After the link has detected an **ID** pin state change, the RID converter can be used to determine the resistor value as described in [Section 5.6.1.2](#).

5.6.1.2 Measuring ID Resistance to Ground

The Link can use the integrated resistance measurement capabilities to determine the value of an ID resistance to ground. The following table details the valid values of resistance, to ground, the USB332x can detect.

Table 5.3 Valid Values of ID Resistance to Ground

ID RESISTANCE TO GROUND	RID VALUE
Ground	000
75Ω +/-1%	001
102kΩ +/-1%	010
200kΩ +/-1%	011
440kΩ +/-1%	100
Floating	101

Note: IdPullUp = 0

The Rid resistance can be read while the USB332x is in Synchronous Mode. When a resistor to ground is attached to the ID pin, the state of the IdGnd comparator will change. After the Link has detected ID transition to ground, it can use the methods described in [Section 6.6](#) to operate the Rid converter.

5.6.1.3 Using IdFloat Comparator

Note: The ULPI specification details a method to detect a 102kΩ resistance to ground using the IdFloat comparator. This method can only detect 0ohms, 102kΩ, and floating terminations of the ID pin. Due to this limitation it is recommended to use the RID Converter as described in [Section 5.6.1.2](#).

The ID pin can be either grounded, floated, or connected to ground with a 102kΩ external resistor. To detect the 102K resistor, set the *idPullup* bit in the [OTG Control](#) register, causing the USB332x to apply the 100K internal pull-up connected between the ID pin and VDD33. Set the *idFloatRise* and *idFloatFall* bits in both the [USB Interrupt Enable Rising](#) and [USB Interrupt Enable Falling](#) registers to enable the IdFloat comparator to generate an RXCMD to the Link when the state of the IdFloat changes. As described in [Figure 6.3](#), the alt_int bit of the RXCMD will be set. The values of IdGnd and IdFloat are shown for the three types cables that can attach to the USB Connector in [Table 5.4](#).

Table 5.4 IdGnd and IdFloat vs. ID Resistance to Ground

ID RESISTANCE	IDGND	IDFLOAT
Float	1	1
102K	1	0
GND	0	0

Note: The ULPI register bits *idPullUp*, *idFloatRise*, and *idFloatFall* should be enabled.

To save current when an A Plug is inserted, the internal 102kΩ pull-up resistor can be disabled by clearing the *idPullUp* bit in the [OTG Control](#) register and the *idFloatRise* and *idFloatFall* bits in both the [USB Interrupt Enable Rising](#) and [USB Interrupt Enable Falling](#) registers. If the cable is removed the weak R_{IDW} will pull the ID pin high.

The *IdGnd* value can be read using the ULPI [USB Interrupt Status](#) register, bit 4. In host mode, it can be set to generate an interrupt when *IdGnd* changes by setting the appropriate bits in the [USB Interrupt Enable Rising](#) and [USB Interrupt Enable Falling](#) registers. The *IdFloat* value can be read by reading the ULPI [Carkit Interrupt Status](#) register bit 0.

Note: The IdGnd switch has been provided to ground the ID pin for future applications.

5.6.2 VBUS Monitor and Pulsing

The USB332x includes all of the VBUS comparators required for OTG. The VBUSVId, SessVId, and SessEnd comparators shown in Figure 5.10 are fully integrated into the USB332x. These comparators are used to monitor changes in the VBUS voltage, and the state of each comparator can be read from the USB Interrupt Status register.

The VbusVId comparator is used by the Link, when configured as an A device, to ensure that the VBUS voltage on the cable is valid. The SessVId comparator is used by the Link when configured as both an A or B device to indicate a session is requested or valid. Finally the SessEnd comparator is used by the B-device to indicate a USB session has ended.

Also included in the VBUS Monitor and Pulsing block are the resistors used for VBUS pulsing in SRP. The resistors used for VBUS pulsing include a pull-down to ground and a pull-up to VDD33.

In some applications, voltages much greater than 5.5V may be present at the VBUS pin of the USB connector. The USB332x includes an overvoltage protection circuit that protects the VBUS pin of the USB332x from excessive voltages as shown in Figure 5.10.

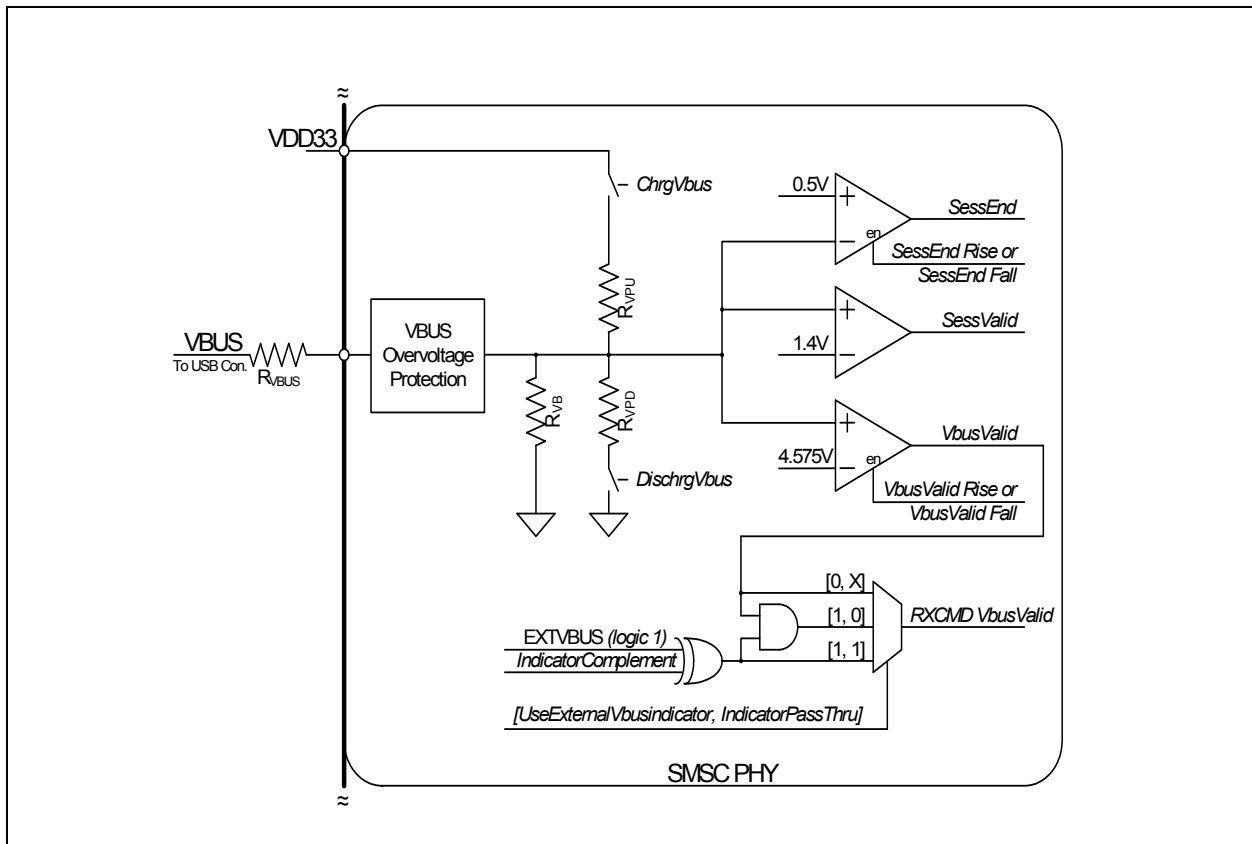

Figure 5.10 USB332x OTG VBUS Block

5.6.2.1 SessEnd Comparator

The SessEnd comparator is designed to trip when VBUS is less than 0.5 volts. When VBUS goes below 0.5 volts the USB session is considered to be ended, and SessEnd will transition from 0 to 1. The SessEnd comparator can be disabled by clearing this bit in both the USB Interrupt Enable Rising and USB Interrupt Enable Falling registers. When disabled, the SessEnd bit in the USB Interrupt Status register will read 0. The SessEnd comparator trip points are detailed in Table 4.7.

Datasheet

5.6.2.2 SessVld Comparator

The SessVld comparator is used when the PHY is configured as both an A and B device. When configured as an A device, the SessVld is used to detect Session Request protocol (SRP). When configured as a B device, SessVld is used to detect the presence of VBUS. The SessVld interrupts can be disabled by clearing this bit in both the [USB Interrupt Enable Rising](#) and [USB Interrupt Enable Falling](#) registers. When the interrupts are disabled, the SessVld comparator is not disabled and its state can be read in the [USB Interrupt Status](#) register. The SessVld comparator trip point is detailed in [Table 4.7](#).

Note: The OTG Supplement specifies a voltage range for A-Device Session Valid and B-Device Session Valid comparator. The USB332x PHY combines the two comparators into one and uses the narrower threshold range.

5.6.2.3 VbusVld Comparator

The final VBUS comparator is the VbusVld comparator. This comparator is only used when the USB332x is configured as an A-device. In the USB protocol the A-device supplies the VBUS voltage and is responsible to ensure it remains within a specified voltage range. The VbusVld comparator can be disabled by clearing this bit in both the [USB Interrupt Enable Rising](#) and [USB Interrupt Enable Falling](#) registers. When disabled, bit 1 of the [USB Interrupt Status](#) register will return a 0. The VbusVld comparator trip points are detailed in [Table 4.7](#).

The internal VbusValid comparator is designed to ensure the VBUS voltage remains above 4.4V.

The USB332x includes the external vbus valid indicator logic as detail in the ULPI Specification. The external vbus valid indicator is tied to a logic one. The decoding of this logic is shown in [Table 5.5](#) below. By default this logic is disabled.

Table 5.5 External VBUS Indicator Logic

TYPICAL APPLICATION	USE EXTERNAL VBUS INDICATOR	INDICATOR PASS THRU	INDICATOR COMPLEMENT	RXCMD VBUS VALID ENCODING SOURCE
OTG Device	0	X	X	Internal VbusVld comparator (Default)
	1	1	0	Fixed 1
	1	1	1	Fixed 0
	1	0	0	Internal VbusVld comparator.
	1	0	1	Fixed 0
Standard Host	1	1	0	Fixed 1
	1	1	1	Fixed 0
Standard Peripheral	0	X	X	Internal VbusVld comparator. This information should not be used by the Link. (Note 5.3)

Note 5.3 A peripheral should not use VbusVld to begin operation. The peripheral should use SessVld because the internal VbusVld threshold can be above the VBUS voltage required for USB peripheral operation.

5.6.2.4 VBUS Pulsing with Pull-up and Pull-down Resistors

In addition to the internal VBUS comparators, the USB332x also includes the integrated VBUS pull-up and pull-down resistors used for VBUS Pulsing during OTG Session Request Protocol. To discharge the VBUS voltage so that a Session Request can begin, the USB332x provides a pull-down resistor from VBUS to Ground. This resistor is controlled by the *DischargeVbus* bit 3 of the **OTG Control** register. The pull-up resistor is connected between VBUS and VDD33. This resistor is used to pull VBUS above 2.1 volts so that the A-Device knows that a USB session has been requested. The state of the pull-up resistor is controlled by the bit 4 *ChargeVbus* of the **OTG Control** register. The Pull-Up and Pull-Down resistor values are detailed in [Table 4.7](#).

The internal VBUS Pull-up and Pull-down resistors are designed to include the R_{VBUS} external resistor in series. This external resistor is used by the VBUS Overvoltage protection described below.

5.6.2.5 VBUS Input Impedance

The OTG Supplement requires an A-Device that supports Session Request Protocol to have a VBUS input impedance less than 100k Ω and greater the 40k Ω to ground. The USB332x provides a 75k Ω resistance to ground, R_{VB} . The R_{VB} resistor tolerance is detailed in [Table 4.7](#).

5.6.2.6 VBUS Overvoltage Protection

The USB332x provides an integrated overvoltage protection circuit to protect the **VBUS** pin from excessive voltages that may be present at the USB connector. The overvoltage protection circuit works with an external resistor (R_{VBUS}) by drawing current across the resistor to reduce the voltage at the **VBUS** pin.

When voltage at the **VBUS** pin exceeds 5.5V, the Overvoltage Protection block will sink current to ground until VBUS is below 5.5V. The current drops the excess voltage across R_{VBUS} and protects the USB332x **VBUS** pin. The required R_{VBUS} value is dependent on the operating mode of the USB332x as shown in [Table 5.6](#).

Table 5.6 Required R_{VBUS} Resistor Value

OPERATING MODE	R_{VBUS}
Device only	10k Ω \pm 5%
OTG Capable	1k Ω \pm 5%
Host <i>UseExternalVbusIndicator = 1</i>	10k Ω \pm 5%

The Overvoltage Protection circuit is designed to protect the USB332x from continuous voltages up to 30V on the R_{VBUS} resistor.

The R_{VBUS} resistor must be sized to handle the power dissipated across the resistor. The resistor power can be found using the equation below:

$$P_{R_{VBUS}} = \frac{(V_{\text{protect}} - 5.0)^2}{R_{VBUS}}$$

Where:

- V_{protect} is the VBUS protection required
- R_{VBUS} is the resistor value, 1k Ω or 10k Ω .
- $P_{R_{VBUS}}$ is the required power rating of R_{VBUS}

Datasheet

For example, protecting a peripheral or device only application to 15V would require a 10k Ω R_{VBUS} resistor with a power rating of 0.01W. To protect an OTG product to 15V would require a 1k Ω R_{VBUS} resistor with a power rating of 0.1W.

5.6.3 Driving External VBUS

The USB332x monitors VBUS as described in [VBUS Monitor and Pulsing](#). The USB332x does not provide an external output for the *DrvVbusExternal* ULPI register. For OTG and Host applications, the external VBUS supply or power switch must be controlled by the Link as shown in [Figure 8.2](#).

5.7 USB UART Support

The USB332x provides support for the USB UART interface as detailed in the ULPI specification and the former CEA-936A specification. The USB332x can be placed in UART Mode using the method described in [Section 6.5](#), and the regulator output will automatically switch to the value configured by the *UART RegOutput bits* in the [USB IO & Power Management](#) register. While in UART mode, the Linestate signals cannot be monitored on the DATA[0] and DATA[1] pins.

5.8 USB Charger Detection Support

To support the detection and identification of different types of USB chargers the USB332x provides integrated pull-up resistors, R_{CD} , on both DP and DM. These pull-up resistors along with the single ended receivers can be used to help determine the type of USB charger attached. Reference information on implementing charger detection is provided in [Section 8.2](#).

Table 5.7 USB Weak Pull-up Enable

RESETB	DP PULLUP ENABLE	DM PULLUP ENABLE
0	0	0
1	<i>ChargerPullupEnableDP</i>	<i>ChargerPullupEnableDM</i>

Note: *ChargerPullupEnableDP* and *ChargerPullupEnableDM* are enabled in the [USB IO & Power Management](#) register.

5.9 USB Audio Support

Note: The USB332x supports “USB Digital Audio” through the USB protocol in ULPI and USB Serial modes described in [Section 6](#).

The USB332x provides two low resistance analog switches that allow analog audio to be multiplexed over the DP and DM terminals of the USB connector. The audio switches are shown in [Figure 5.1](#). The electrical characteristics of the USB Audio Switches are provided in [Table 4.8](#).

During normal USB operation the switches are off. When USB Audio is desired the switches can be turned “on” by enabling the *SpkLeftEn*, *SpkRightEn*, or *MicEn* bits in the [Carkit Control](#) register as described in [Section 6.5.2](#). These bits are disabled by default. The USB Audio Switches can also be enabled by asserting the **RESETB** pin or removing the voltage at **VDD18** as shown in [Table 5.8](#). While using the USB switches, **VDD18** is not required, but 3.3V must be present at **VDD33**. The integrated 3.3V LDO regulator may be used to generate **VDD33** from power applied at the VBAT pin.

Table 5.8 USB Audio Switch Enable

RESETB	VDD18	DP SWITCH ENABLE	DM SWITCH ENABLE
X	0	1	1
0	1	1	1
1	1	<i>SpkLeftEn</i>	<i>SpkRightEn</i> or <i>MicEn</i>

Note: *SpkLeftEn*, *SpkRightEn*, and *MicEn* are enabled in the [Carkit Control](#) register.

In addition to USB Audio support the switches can also be used to multiplexed a second FS USB PHY to the USB connector. The signal quality will be degraded slightly due to the “on” resistance of the switches. The USB332x single-ended receivers described in [Section 5.2.1](#) are disabled when either USB Audio switch is enabled.

The USB332x does not provide the DC bias for the audio signals. The **SPK_R** and **SPK_L** pins should be biased to 1.65V when audio signals are routed through the USB332x. This DC bias is necessary to prevent the audio signal from swinging below ground and being clipped by ESD Diodes.

When the system is not using the USB Audio switches, the **SPK_R** and **SPK_L** pins should not be connected.

Chapter 6 ULPI Operation

6.1 Overview

The USB332x uses the industry standard ULPI digital interface to facilitate communication between the PHY and Link (device controller). The ULPI interface is designed to reduce the number of pins required to connect a discrete USB PHY to an ASIC or digital controller. For example, a full UTMI+ Level 3 OTG interface requires 54 signals while a ULPI interface requires only 12 signals.

The ULPI interface is documented completely in the “UTMI+ Low Pin Interface (ULPI) Specification Revision 1.1”. The following sections describe the operating modes of the USB332x digital interface.

Figure 6.1 illustrates the block diagram of the ULPI digital functions. It should be noted that this USB332x does not use a “ULPI wrapper” around a UTMI+ PHY core as the ULPI specification implies.

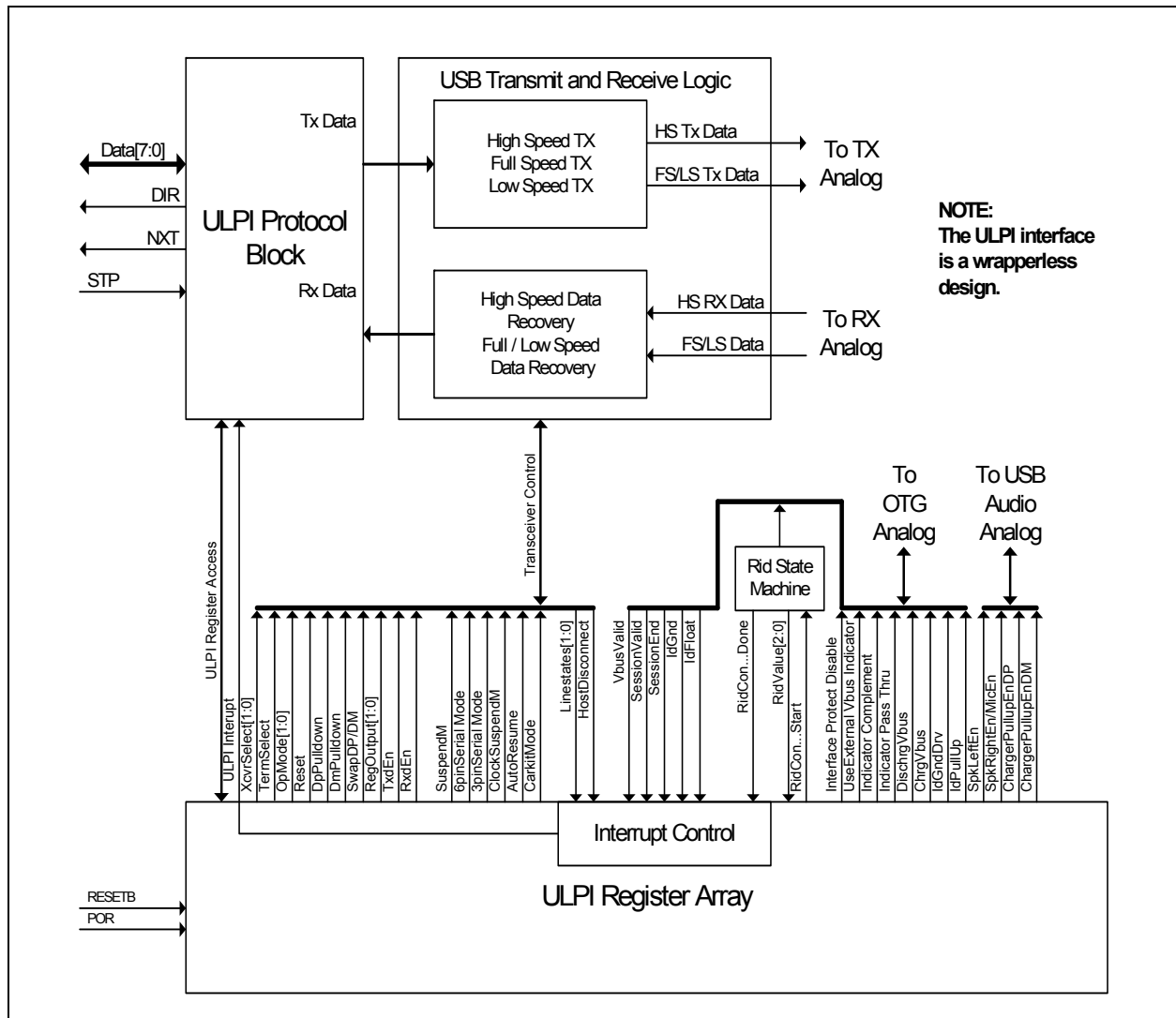

Figure 6.1 ULPI Digital Block Diagram

The advantage of a “wrapper less” architecture is that the USB332x has a lower USB latency than a design which must first register signals into the PHY’s wrapper before the transfer to the PHY core. A

low latency PHY allows a Link to use a wrapper around a UTMI Link and still make the required USB turn-around timing given in the USB 2.0 specification.

RxEndDelay maximum allowed by the UTMI+/ULPI for 8-bit data is 63 high speed clocks. USB332x uses a low latency high speed receiver path to lower the RxEndDelay to 43 high speed clocks. This low latency design gives the Link more cycles to make decisions and reduces the Link complexity. This is the result of the “wrapper less” architecture of the USB332x. This low RxEndDelay should allow legacy UTMI Links to use a “wrapper” to convert the UTMI+ interface to a ULPI interface.

In [Figure 6.1](#), a single ULPI Protocol Block decodes the ULPI 8-bit bi-directional bus when the Link addresses the PHY. The Link must use the **DIR** output to determine direction of the ULPI data bus. The USB332x is the “bus arbitrator”. The ULPI Protocol Block will route data/commands to the transmitter or the ULPI register array.

6.1.1 ULPI Interface Signals

The UTMI+ Low Pin Interface (ULPI) uses twelve pins to connect a full OTG Host / Device PHY to an SOC. A reduction of external pins on the PHY is accomplished by realizing that many of the relatively static configuration pins (xcvrselect[1:0], termselect, opmode[1:0], and DpPullDown DmPullDown to list a few,) can be implemented by having an internal static register array.

An 8-bit bi-directional data bus clocked at 60MHz allows the Link to access this internal register array and transfer USB packets to and from the PHY. The remaining 3 pins function to control the data flow and arbitrate the data bus.

Direction of the 8-bit data bus is controlled by the **DIR** output from the PHY. Another output, **NXT**, is used to control data flow into and out of the device. Finally, **STP**, which is an input to the PHY, terminates transfers and is used to start up and resume from Low Power Mode.

The twelve signals are described below in [Table 6.1](#).

Table 6.1 ULPI Interface Signals

SIGNAL	DIRECTION	DESCRIPTION
CLK	I/O	60MHz ULPI clock. All ULPI signals are driven synchronous to the rising edge of this clock. This clock can be either driven by the PHY or the Link as described in Section 5.4.1
DATA[7:0]	I/O	8-bit bi-directional data bus. Bus ownership is determined by DIR. The Link and PHY initiate data transfers by driving a non-zero pattern onto the data bus. ULPI defines interface timing for a single-edge data transfers with respect to rising edge of the ULPI clock.
DIR	OUT	Controls the direction of the data bus. When the PHY has data to transfer to the Link, it drives DIR high to take ownership of the bus. When the PHY has no data to transfer it drives DIR low and monitors the bus for commands from the Link. The PHY will pull DIR high whenever the interface cannot accept data from the Link, such as during PLL start-up.
STP	IN	The Link asserts STP for one clock cycle to stop the data stream currently on the bus. If the Link is sending data to the PHY, STP indicates the last byte of data was on the bus in the previous cycle.
NXT	OUT	The PHY asserts NXT to throttle the data. When the Link is sending data to the PHY, NXT indicates when the current byte has been accepted by the PHY. The Link places the next byte on the data bus in the following clock cycle.

USB332x implements a Single Data Rate (SDR) ULPI interface with all data transfers happening on the rising edge of the 60MHz ULPI Clock while operating in Synchronous Mode. The direction of the data bus is determined by the state of **DIR**. When **DIR** is high, the PHY is driving **DATA[7:0]**. When **DIR** is low, the Link is driving **DATA[7:0]**.

Datasheet

Each time DIR changes, a “turn-around” cycle occurs where neither the Link nor PHY drive the data bus for one clock cycle. During the “turn-around” cycle, the state of **DATA[7:0]** is unknown and the PHY will not read the data bus.

Because USB uses a bit-stuffing encoding, some means of allowing the PHY to throttle the USB transmit data is needed. The ULPI signal **NXT** is used to request the next byte to be placed on the data bus by the Link layer.

The ULPI interface supports the two basic modes of operation: Synchronous Mode and asynchronous modes that include Low Power Mode, Serial Modes, and CarKit Mode. In Synchronous Mode, all signals change synchronously with the 60MHz ULPI clock. In asynchronous modes the clock is off and the ULPI bus is redefined to bring out the signals required for that particular mode of operations. The description of synchronous Mode is described in the following sections while the descriptions of the asynchronous modes are described in [Section 6.3](#), [Section 6.4](#), and [Section 6.5](#).

6.1.2 ULPI Interface Timing in Synchronous Mode

The control and data timing relationships are given in [Figure 6.2](#) and [Table 4.3](#). All timing is relative to the rising clock edge of the 60MHz ULPI Clock.

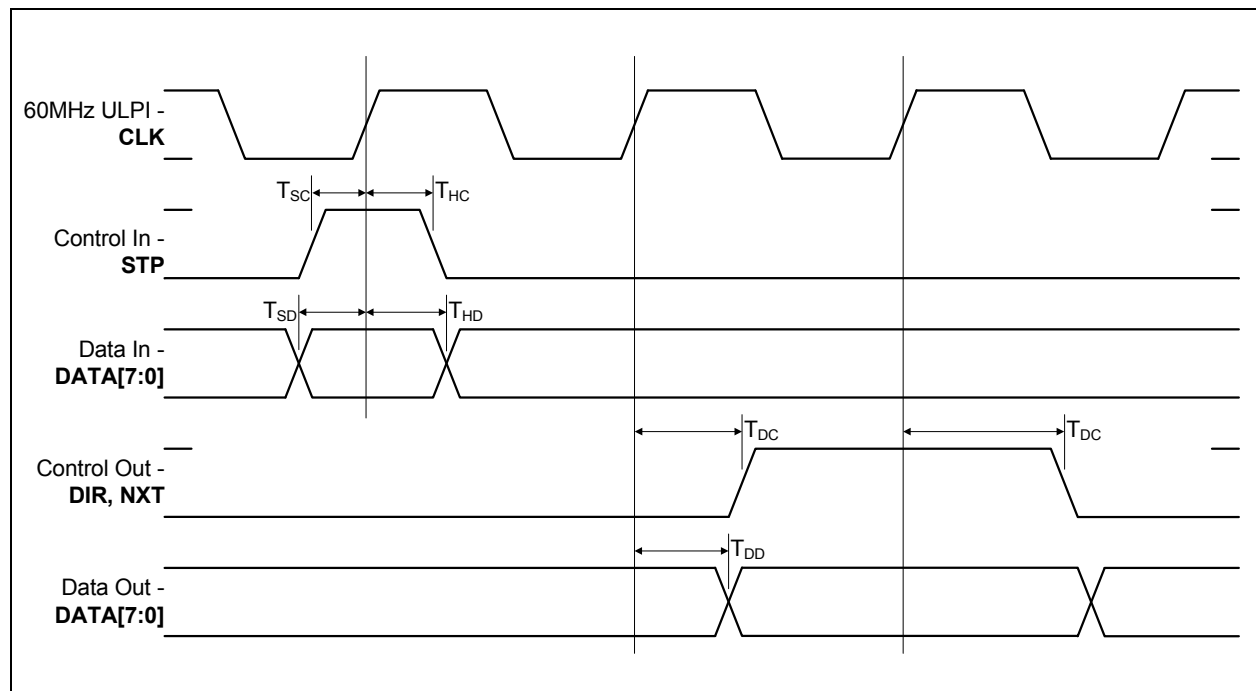

Figure 6.2 ULPI Single Data Rate Timing Diagram in Synchronous Mode

6.2 ULPI Register Access

A command from the Link begins a ULPI transfer from the Link to the USB332x. Before reading a ULPI register, the Link must wait until DIR is low, and then send a Transmit Command Byte (TXD CMD) byte. The TXD CMD byte informs the USB332x of the type of data being sent. The TXD CMD is followed by a data transfer to or from the USB332x. [Table 6.2](#) gives the TXD command byte (TXD CMD) encoding for the USB332x. The upper two bits of the TX CMD instruct the PHY as to what type of packet the Link is transmitting. The ULPI registers retain their contents when the PHY is in Low Power Mode, Full Speed/Low Speed Serial Mode, or CarKit Mode.

Table 6.2 ULPI TXD CMD Byte Encoding

COMMAND NAME	CMD BITS[7:6]	CMD BITS[5:0]	COMMAND DESCRIPTION
Idle	00b	000000b	ULPI Idle
Transmit	01b	000000b	USB Transmit Packet with No Packet Identifier (NOPID)
		00XXXXb	USB Transmit Packet Identifier (PID) where DATA[3:0] is equal to the 4-bit PID. P ₃ P ₂ P ₁ P ₀ where P ₃ is the MSB.
Register Write	10b	XXXXXXb	Immediate Register Write Command where: DATA[5:0] = 6-bit register address
		101111b	Extended Register Write Command where the 8-bit register address is available on the next cycle.
Register Read	11b	XXXXXXb	Immediate Register Read Command where: DATA[5:0] = 6-bit register address
		101111b	Extended Register Read Command where the 8-bit register address is available on the next cycle.

6.2.1 ULPI Register Write

A ULPI register write operation is given in Figure 6.3. The TXD command with a register write **DATA[7:6]** = 10b is driven by the Link at T₀. The register address is encoded into **DATA[5:0]** of the TXD CMD byte.

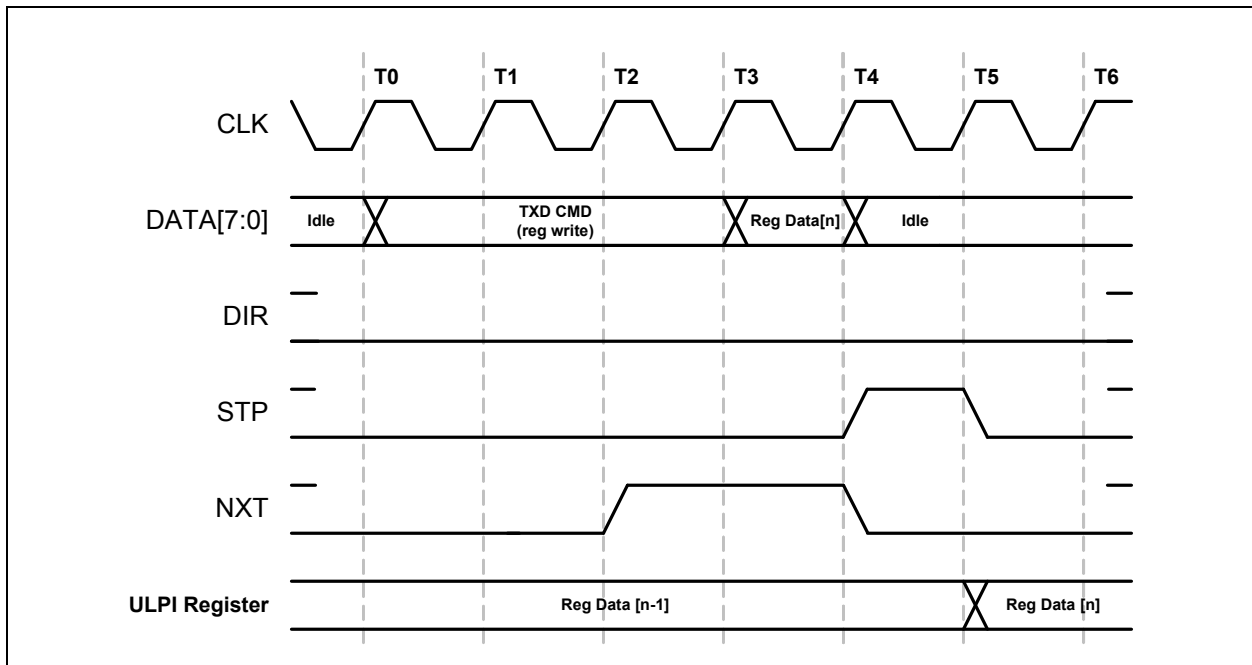

Figure 6.3 ULPI Register Write in Synchronous Mode

To write a register, the Link will wait until **DIR** is low, and at T₀, drive the TXD CMD on the data bus. At T₂ the PHY will drive **NXT** high. On the next rising clock edge, T₃, the Link will write the register

Datasheet

data. At T4, the PHY will accept the register data and drive **NXT** low. The Link will drive an Idle on the bus and drive **STP** high to signal the end of the data packet. Finally, at T5, the PHY will latch the data into the register and the Link will pull **STP** low.

NXT is used to control when the Link drives the register data on the bus. **DIR** is low throughout this transaction since the PHY is receiving data from the Link. **STP** is used to end the transaction and data is registered after the de-assertion of **STP**. After the write operation completes, the Link must drive a ULPI Idle (00h) on the data bus or the USB332x may decode the bus value as a ULPI command.

A ULPI extended register write operation is shown in Figure 6.4. To write an extended register, the Link will wait until **DIR** is low, and at T0, drive the TXD CMD on the data bus. At T2 the PHY will drive **NXT** high. On the next clock T3 the Link will drive the extended address. On the next rising clock edge, T4, the Link will write the register data. At T5, the PHY will accept the register data and drive **NXT** low. The Link will drive an Idle on the bus and drive **STP** high to signal the end of the data packet. Finally, at T5, the PHY will latch the data into the register. The Link will pull **STP** low.

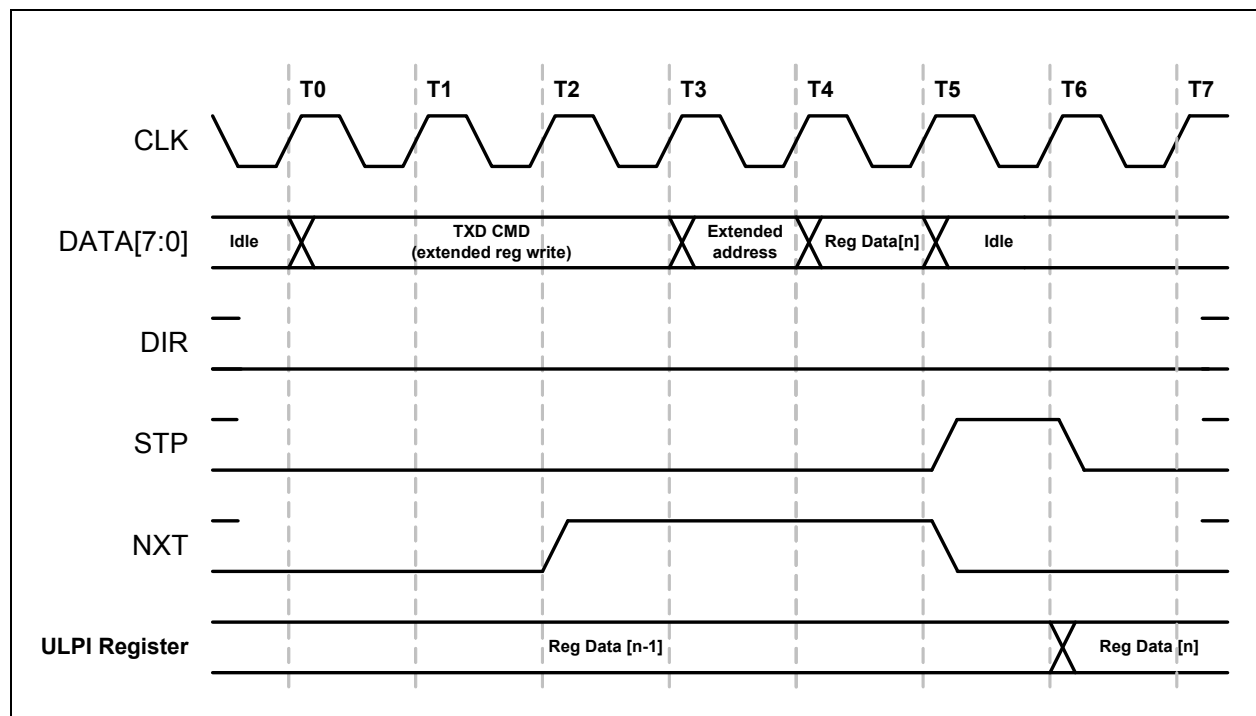

Figure 6.4 ULPI Extended Register Write in Synchronous Mode

6.2.2 ULPI Register Read

A ULPI register read operation is given in [Figure 6.5](#). The Link drives a TXD CMD byte with **DATA[7:6]** = 11h for a register read. **DATA[5:0]** of the ULPI TXD command byte contain the register address.

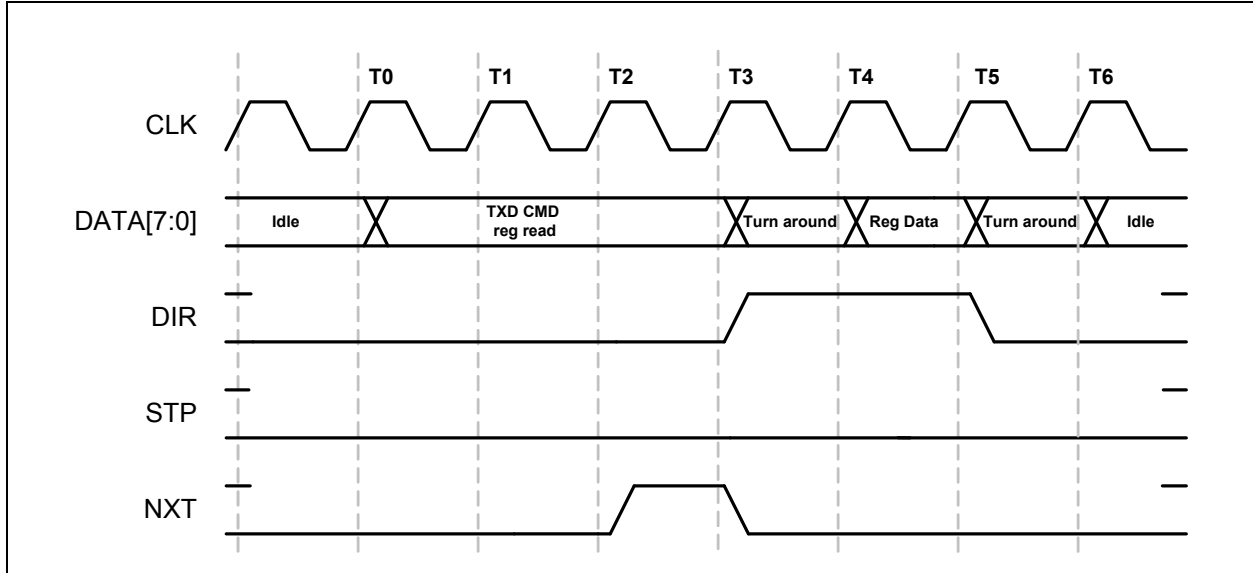

Figure 6.5 ULPI Register Read in Synchronous Mode

At T0, the Link will place the TXD CMD on the data bus. At T2, the PHY will bring **NXT** high, signaling the Link it is ready to accept the data transfer. At T3, the PHY reads the TXD CMD, determines it is a register read, and asserts **DIR** to gain control of the bus. The PHY will also de-assert **NXT**. At T4, the bus ownership has transferred back to the PHY and the PHY drives the requested register onto the data bus. At T5, the Link will read the data bus and the PHY will drop **DIR** low returning control of the bus back to the Link. After the turn around cycle, the Link must drive a ULPI Idle command at T6.

A ULPI extended register read operation is shown in [Figure 6.6](#). To read an extended register, the Link writes the TX CMD with the address set to 2Fh. At T2, the PHY will assert **NXT**, signaling the Link it is ready to accept the extended address. At T3, the Link places the extended register address on the bus. At T4, the PHY reads the extended address, and asserts **DIR** to gain control of the bus. The PHY will also de-assert **NXT**. At T5, the bus ownership has transferred back to the PHY and the PHY drives the requested register onto the data bus. At T6, the Link will read the data bus and the PHY will de-assert **DIR** returning control of the bus back to the Link. After the turn around cycle, the Link must drive a ULPI Idle command at T6.

Datasheet

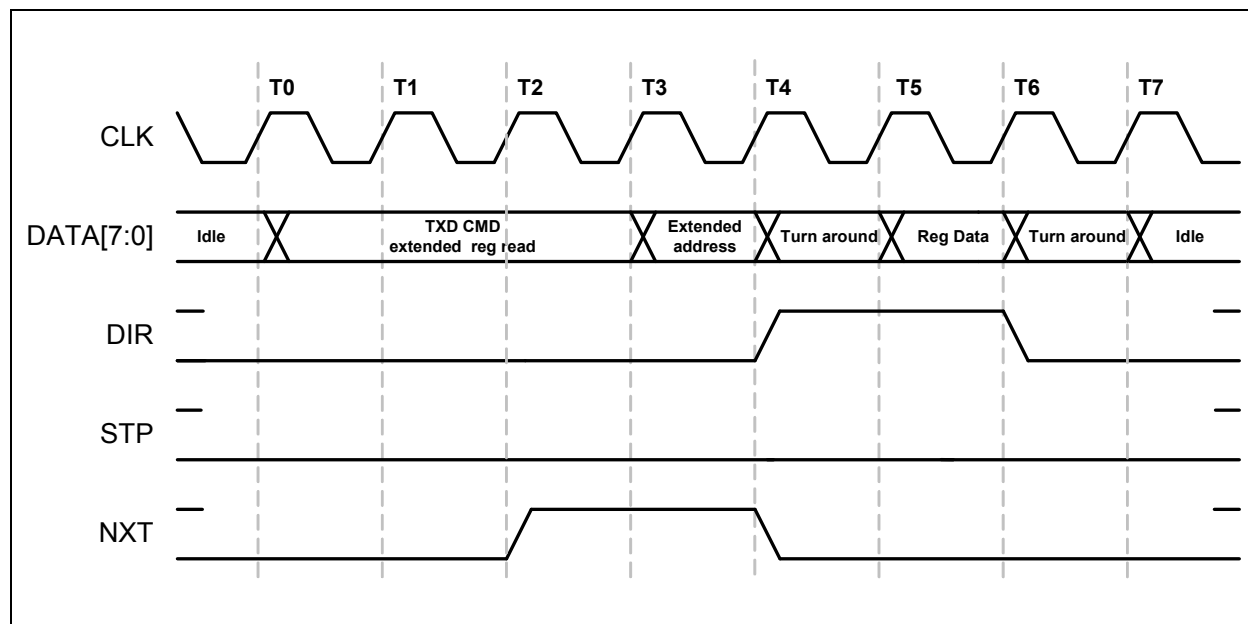

Figure 6.6 ULPI Extended Register Read in Synchronous Mode

6.2.3 ULPI RXCMD

The ULPI Link needs information which was provided by the following pins in a UTMI implementation: `linestate[1:0]`, `rxactive`, `rxvalid` and `rxerror`. When implementing the OTG functions, the **VBUS** and **ID** pin states must also be transferred to the Link.

ULPI defines a Receive Command Byte (RXCMD) that contains this information. The Encoding of the RXCMD byte is given in the [Table 6.3](#).

Transfer of the RXCMD byte occurs in Synchronous Mode when the PHY has control of the bus. The ULPI Protocol Block shown in [Figure 6.1](#) determines when to send an RXCMD.

A RXCMD can occur:

- When a `linestate` change occurs.
- When `VBUS` or `ID` comparators change state.
- During a USB receive when **NXT** is low.
- After the USB332x deasserts **DIR** and **STP** is low during start-up
- After the USB332x exits Low Power Mode, Serial Modes, or CarKit Mode after detecting that the Link has de-asserted **STP**, and **DIR** is low.

When a USB Receive is occurring, RXCMD's are sent whenever **NXT** = 0 and **DIR** = 1. During a USB Transmit, the RXCMD's are returned to the Link after **STP** is asserted.

If an RXCMD event occurs during a USB transmit, the RXCMD is blocked until **STP** de-asserts at the end of the transmit. The RXCMD contains the status that is current at the time the RXCMD is sent.

Table 6.3 ULPI RX CMD Encoding

DATA[7:0]	NAME	DESCRIPTION AND VALUE				
[1:0]	Linestate	UTMI Linestate Signals Note 6.1				
[3:2]	Encoded VBUS State	ENCODED VBUS VOLTAGE STATES				
		VALUE	VBUS VOLTAGE	SESEND	SESSVLD	VBUSVLD₂
		00	$V_{VBUS} < V_{SESS_END}$	1	0	0
		01	$V_{SESS_END} < V_{VBUS} < V_{SESS_VLD}$	0	0	0
		10	$V_{SESS_VLD} < V_{VBUS} < V_{VBUS_VLD}$	X	1	0
11	$V_{VBUS_VLD} < V_{VBUS}$	X	X	1		
[5:4]	Rx Event Encoding	ENCODED UTMI EVENT SIGNALS				
		VALUE	RXACTIVE	RXERROR	HOSTDISCONNECT	
		00	0	0	0	
		01	1	0	0	
		11	1	1	0	
10	X	X	1			
[6]	State of ID pin	Set to the logic state of the ID pin. A logic low indicates an A device. A logic high indicates a B device.				
[7]	alt_int	Asserted when a non-USB interrupt occurs. This bit is set when an unmasked event occurs on any bit in the Carkit Interrupt Latch register. The Link must read the Carkit Interrupt Latch register to determine the source of the interrupt. Section 5.6.1.3 describes how a change on the ID pin can generate an interrupt. Section 6.6 describes how an interrupt can be generated when the <i>RidConversionDone</i> bit is set.				

Notes:

1. An 'X' is a do not care and can be either a logic 0 or 1.
2. The value of VbusValid is defined in [Table 5.5](#).

Note 6.1 LineState: These bits in the RXCMD byte reflect the current state of the Full-Speed single ended receivers. LineState[0] directly reflects the current state of **DP**. LineState[1] directly reflects the current state of **DM**. When **DP=DM=0** this is called "Single Ended Zero" (SE0). When **DP=DM=1**, this is called "Single Ended One" (SE1).

6.2.4 USB332x Transmitter

The USB332x ULPI transmitter fully supports HS, FS, and LS transmit operations. [Figure 6.1](#) shows the high speed, full speed, and low speed transmitter block controlled by ULPI Protocol Block. Encoding of the USB packet follows the bit-stuffing and NRZI outlined in the USB 2.0 specification. Many of these functions are re-used between the HS and FS/LS transmitters. When using the USB332x, [Table 5.1](#) should always be used as a guideline on how to configure for various modes of operation. The transmitter decodes the inputs of *XcvrSelect[1:0]*, *TermSelect*, *OpMode[1:0]*, *DpPulldown*, and *DmPulldown* to determine what operation is expected. Users must strictly adhere to the modes of operation given in [Table 5.1](#).

Datasheet

Several important functions for a device and host are designed into the transmitter blocks.

The USB332x transmitter will transmit a 32-bit long high speed sync before every high speed packet. In full and low speed modes a 8-bit sync is transmitted.

When the device or host needs to chirp for high speed port negotiation, the *OpMode* = 10 setting will turn off the bit-stuffing and NRZI encoding in the transmitter. At the end of a chirp, the USB332x *OpMode* register bits should be changed only after the RXCMD linestate encoding indicates that the transmitter has completed transmitting. Should the opmode be switched to normal bit-stuffing and NRZI encoding before the transmit pipeline is empty, the remaining data in the pipeline may be transmitted in an bit-stuff encoding format.

Please refer to the ULPI specification for a detailed discussion of USB reset and HS chirp.

6.2.4.1 High Speed Long EOP

When operating as a Hi-Speed host, the USB332x will automatically generate a 40 bit long End of Packet (EOP) after a SOF PID (A5h). The USB332x determines when to send the 40-bit long EOP by decoding the ULPI TXD CMD bits [3:0] for the SOF. The 40-bit long EOP is only transmitted when the *DpPulldown* and *DmPulldown* bits in the **OTG Control** register are asserted. The Hi-Speed 40-bit long EOP is used to detect a disconnect in high speed mode.

In device mode, the USB332x will not send a long EOP after a SOF PID.

6.2.4.2 Low Speed Keep-Alive

Low speed keep alive is supported by the USB332x. When in Low speed (10b), the USB332x will send out two Low speed bit times of SE0 when a SOF PID is received.

6.2.4.3 UTMI+ Level 3

Pre-amble is supported for UTMI+ Level 3 compatibility. When *XcvrSelect* is set to (11b) in host mode, (*DpPulldown* and *DmPulldown* both asserted) the USB332x will pre-pend a full speed pre-amble before the low speed packet. Full speed rise and fall times are used in this mode. The pre-amble consists of the following: Full speed sync, the encoded pre-PID (C3h) and then full speed idle (DP=1 and DM = 0). A low speed packet follows with a sync, data and a LS EOP.

The USB332x will only support UTMI+ Level 3 as a host. The USB332x does not support UTMI+ Level 3 as a peripheral. A UTMI+ Level 3 peripheral is an upstream hub port. The USB332x will not decode a pre-amble packet intended for a LS device when the USB332x is configured as the upstream port of a FS hub, *XcvrSelect* = 11b, *DpPulldown* = 0b, *DmPulldown* =0b.

6.2.4.4 Host Resume K

Resume K generation is supported by the USB332x. When the USB332x exits the suspended (Low Power Mode), the USB332x, when operating as a host, will transmit a K on DP/DM. The transmitters will end the K with SE0 for two Low Speed bit times. If the USB332x was operating in high speed mode before the suspend, the host must change to high speed mode before the SE0 ends. SE0 is two low speed bit times which is about 1.2 us. For more details please see sections 7.1.77 and 7.9 of the USB Specification.

In device mode, the resume K will not append an SE0, but release the bus to the correct idle state, depending upon the operational mode as shown in [Table 5.1](#).

The ULPI specification includes a detailed discussion of the resume sequence and the order of operations required. To support Host start-up of less than 1mS the USB332x implements the ULPI *AutoResume* bit in the Interface Control register. The default *AutoResume* state is 0 and this bit should be enabled for Host applications.

6.2.4.5 No SYNC and EOP Generation (*OpMode* = 11)

UTMI+ defines *OpMode* = 11 where no sync and EOP generation occurs in Hi-Speed operation. This is an option to the ULPI specification and not implemented in the USB332x.

6.2.4.6 Typical USB Transmit with ULPI

Figure 6.7 shows a typical USB transmit sequence. A transmit sequence starts by the Link sending a TXD CMD where **DATA[7:6]** = 01b, **DATA[5:4]** = 00b, and **Data[3:0]** = PID. The TX CMD with the PID is followed by transmit data.

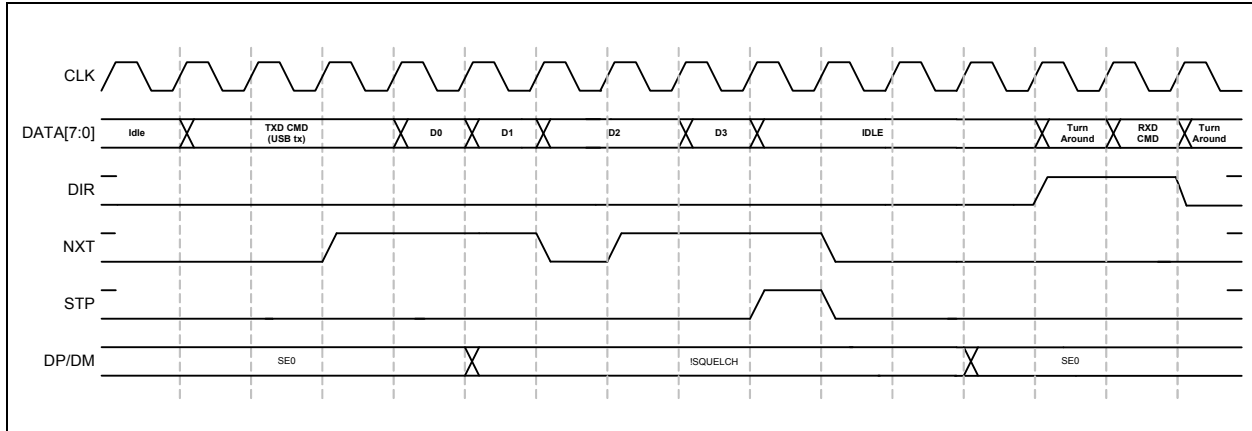

Figure 6.7 ULPI Transmit in Synchronous Mode

During transmit the PHY will use **NXT** to control the rate of data flow into the PHY. If the USB332x pipeline is full or bit-stuffing causes the data pipeline to overflow **NXT** is de-asserted and the Link will hold the value on Data until **NXT** is asserted. The USB Transmit ends when the Link asserts **STP** while **NXT** is asserted.

Note: The Link cannot assert **STP** with **NXT** de-asserted since the USB332x is expecting to fetch another byte from the Link.

After the USB332x completes transmitting, the **DP** and **DM** lines return to idle and a RXCMD is returned to the Link so the inter-packet timers may be updated by linestate.

While operating in Full Speed or Low Speed, an End-of-Packet (EOP) is defined as SE0 for approximately two bit times, followed by J for one bit time. The transceiver drives a J state for one bit time following the SE0 to complete the EOP. The Link must wait for one bit time following line state indication of the SE0 to J transition to allow the transceiver to complete the one bit time J state. All bit times are relative to the speed of transmission.

In the case of Full Speed or Low Speed, after **STP** is asserted each FS/LS bit transition will generate a RXCMD since the bit times are relatively slow.

6.2.5 USB Receiver

The USB332x ULPI receiver fully supports HS, FS, and LS transmit operations. In all three modes the receiver detects the start of packet and synchronizes to the incoming data packet. In the ULPI protocol, a received packet has the priority and will immediately follow register reads and RXCMD transfers. Figure 6.8 shows a basic USB packet received by the USB332x over the ULPI interface.

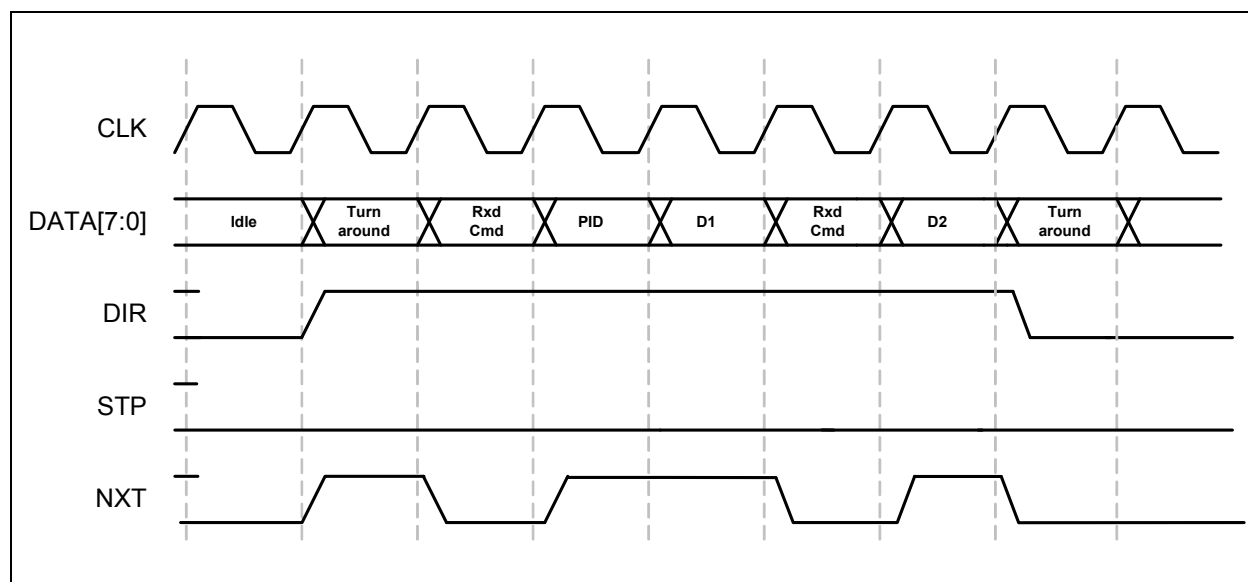

Figure 6.8 ULPI Receive in Synchronous Mode

In Figure 6.8 the PHY asserts **DIR** to take control of the data bus from the Link. The assertion of **DIR** and **NXT** in the same cycle contains additional information that Ractive has been asserted. When **NXT** is de-asserted and **DIR** is asserted, the RXCMD data is transferred to the Link. After the last byte of the USB receive packet is transferred to the PHY, the linestate will return to idle.

The ULPI full speed receiver operates according to the UTMI / ULPI specification. In the full speed case, the **NXT** signal will assert only when the Data bus has a valid received data byte. When **NXT** is low with **DIR** high, the RXCMD is driven on the data bus.

In full speed, the USB332x will not issue a Ractive de-assertion in the RXCMD until the DP/DM linestate transitions to idle. This prevents the Link from violating the two full speed bit times minimum turn around time.

6.2.5.1 Disconnect Detection

A High Speed host must detect a disconnect by sampling the transmitter outputs during the long EOP transmitted during a SOF packet. The USB332x only looks for a high speed disconnect during the long EOP where the period is long enough for the disconnect reflection to return to the host PHY. When a high speed disconnect occurs, the USB332x will return a RXCMD and set the host disconnect bit in the [USB Interrupt Status](#) register.

When in FS or LS modes, the Link is expected to handle all disconnect detection.

6.3 Low Power Mode

Low Power Mode is a power down state to save current when the USB session is suspended. The Link controls when the PHY is placed into or out of Low Power Mode. In Low Power Mode all of the circuits are powered down except the interface pins, full speed receiver, VBUS comparators, and IdGnd comparator.

Before entering Low Power Mode, the USB332x must be configured to set the desired state of the USB transceiver. The *XcvrSelect[1:0]*, *TermSelect* and *OpMode[1:0]* bits in the [Function Control](#) register, and the *DpPulldown* and *DmPulldown* bits in the [OTG Control](#) register control the configuration as shown in [Table 5.1](#). The **DP** and **DM** pins are configured to a high impedance state by configuring *OpMode[1:0]* = 01. Pull-down resistors with a value of approximately 2MΩ are present

on the **DP** and **DM** pins to avoid false linestate indications that could result if the pins were allowed to float.

6.3.1 Entering Low Power/Suspend Mode

To enter Low Power Mode, the Link will write a 0 or clear the *SuspendM* bit in the *Function Control* register. After this write is complete, the PHY will assert **DIR** high and after a minimum of five rising edges of **CLKOUT**, drive the clock low. After the clock is stopped, the PHY will enter a low power state to conserve current. Placing the PHY in Suspend Mode is not related to USB Suspend. To clarify this point, USB Suspend is initiated when a USB host stops data transmissions and enters Full-Speed mode with 15KΩ pull-down resistors on **DP** and **DM**. The suspended device goes to Full-Speed mode with a pull-up on **DP**. Both the host and device remain in this state until one of them drives **DM** high (this is called a resume).

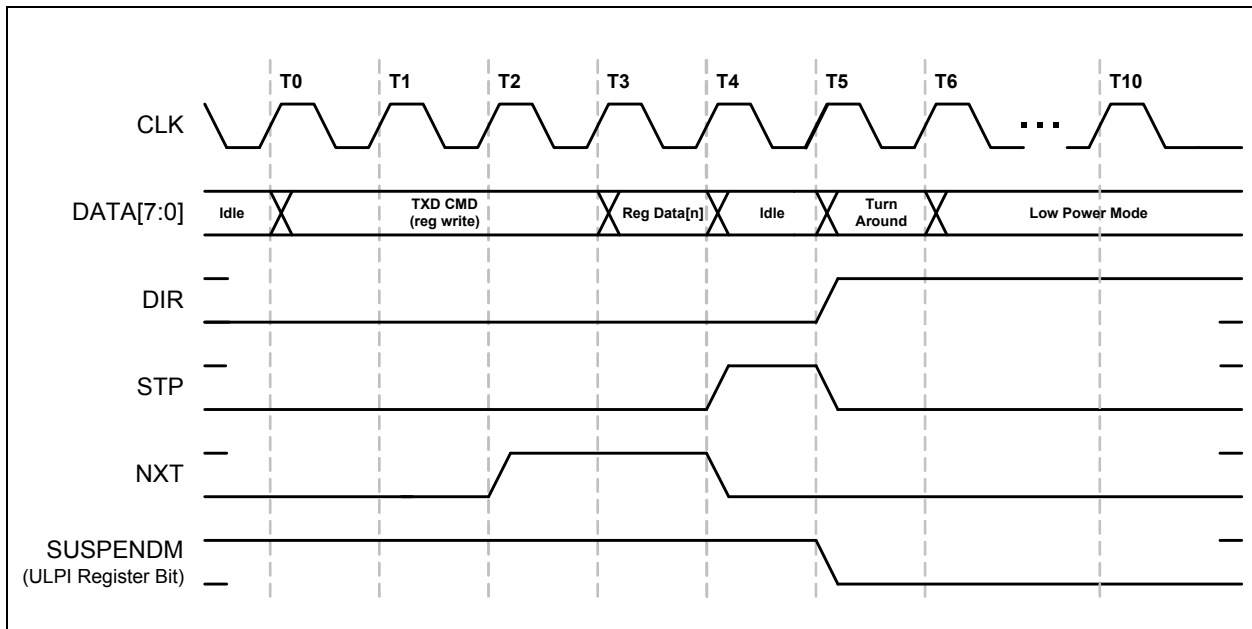

Figure 6.9 Entering Low Power Mode from Synchronous Mode

While in Low Power Mode, the Data interface is redefined so that the Link can monitor Linestate and the VBUS voltage. In Low Power Mode **DATA[3:0]** are redefined as shown in [Table 6.4](#). Linestate[1:0] is the combinational output of the Single-Ended Receivers. The “int” or interrupt signal indicates an unmasked interrupt has occurred. When an unmasked interrupt or linestate change has occurred, the Link is notified and can determine if it should wake-up the PHY.

Table 6.4 Interface Signal Mapping During Low Power Mode

SIGNAL	MAPS TO	DIRECTION	DESCRIPTION
linestate[0]	DATA[0]	OUT	Combinatorial LineState[0] driven directly by the Full-Speed single ended receiver. Note 6.2
linestate[1]	DATA[1]	OUT	Combinatorial LineState[1] driven directly by the Full-Speed single ended receiver. Note 6.2
reserved	DATA[2]	OUT	Driven Low
int	DATA[3]	OUT	Active high interrupt indication. Must be asserted whenever any unmasked interrupt occurs.
reserved	DATA[7:4]	OUT	Driven Low

Datasheet

Note 6.2 LineState: These signals reflect the current state of the Full-Speed single ended receivers. LineState[0] directly reflects the current state of **DP**. LineState[1] directly reflects the current state of **DM**. When **DP=DM=0** this is called "Single Ended Zero" (SE0). When **DP=DM=1**, this is called "Single Ended One" (SE1).

An unmasked interrupt can be caused by the following comparators changing state: VbusVld, SessVld, SessEnd, and IdGnd. If any of these signals change state during Low Power Mode and the bits are enabled in either the [USB Interrupt Enable Rising](#) or [USB Interrupt Enable Falling](#) registers, **DATA[3]** will assert. During Low Power Mode, the VbusVld and SessEnd comparators can have their interrupts masked to lower the suspend current as described in [Section 6.3.4](#).

While in Low Power Mode, the Data bus is driven asynchronously because all of the PHY clocks are stopped during Low Power Mode.

6.3.2 Exiting Low Power Mode

To exit Low Power Mode, the Link will assert **STP**. Upon the assertion of **STP**, the USB332x will begin its start-up procedure. After the PHY start-up is complete, the PHY will start the clock on **CLKOUT** and de-assert **DIR**. After **DIR** has been de-asserted, the Link can de-assert **STP** when ready and start operating in Synchronous Mode. The PHY will automatically set the *SuspendM* bit to a 1 in the [Function Control](#) register.

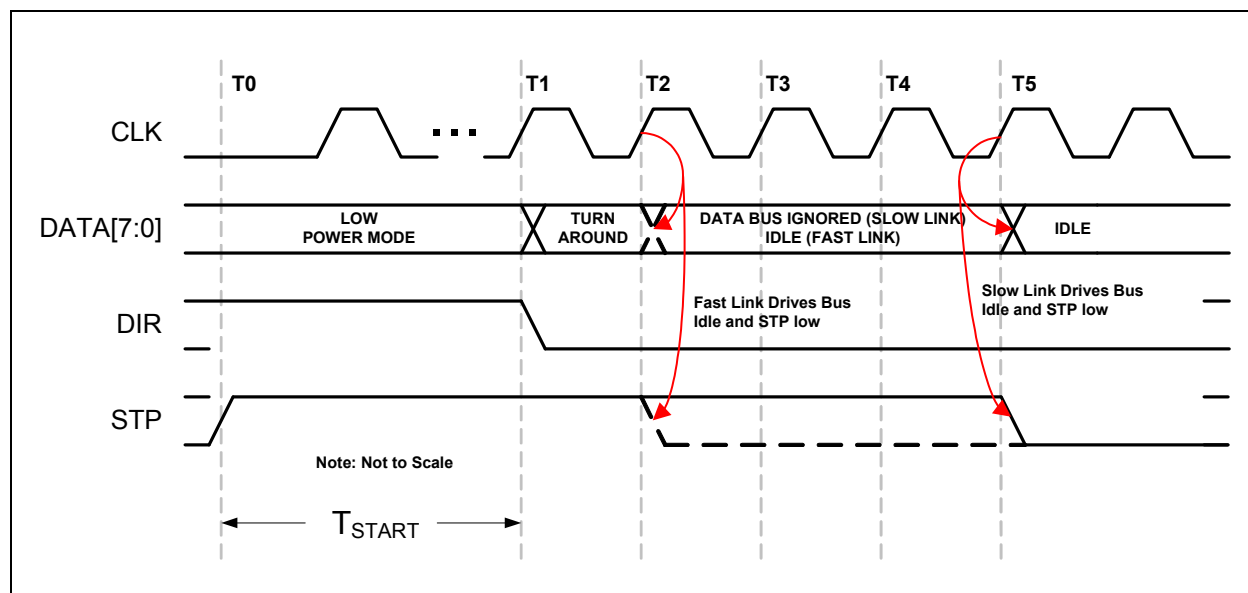

Figure 6.10 Exiting Low Power Mode

The value for T_{START} is given in [Table 4.2](#).

Should the Link de-assert **STP** before **DIR** is de-asserted, the USB332x will detect this as a false resume request and return to Low Power Mode. This is detailed in section 3.9.4 of the ULPI 1.1 specification.

6.3.3 Interface Protection

ULPI protocol assumes that both the Link and PHY will keep the ULPI data bus driven by either the Link when **DIR** is low or the PHY when **DIR** is high. The only exception is when **DIR** has changed state and a turn around cycle occurs for 1 clock period.

In the design of a USB system, there can be cases where the Link may not be driving the ULPI bus to a known state while **DIR** is low. Two examples where this can happen is because of a slow Link start-up or a hardware reset.

6.3.3.1 Start up Protection

Upon start-up, when the PHY de-asserts **DIR**, the Link must be ready to receive commands and drive Idle on the data bus. If the Link is not ready to receive commands or drive Idle, it must assert **STP** before **DIR** is de-asserted. The Link can then de-assert **STP** when it has completed its start-up. If the Link doesn't assert **STP** before it can receive commands, the **PHY** may interpret the data bus state as a TX CMD and transmit invalid data onto the **USB** bus, or make invalid register writes.

When the USB332x sends a RXCMD the Link is required to drive the data bus back to idle at the end of the turn around cycle. If the Link does not drive the databus to idle the USB332x may take the information on the data bus as a TXCMD and transmit data on **DP** and **DM** until the Link asserts stop. If the **ID** pin is floated the last RXCMD from the USB332x will remain on the bus after **DIR** is de-asserted and the USB332x will take this in as a TXCMD.

A Link should be designed to have the default POR state of the **STP** output high and the data bus tri-stated. The USB332x has weak pull-downs on the data bus to prevent these inputs from floating when not driven. These resistors are only used to prevent the ULPI interface from floating during events when the link ULPI pins may be tri-stated. The strength of the pull down resistors can be found in [Table 4.4](#). The pull downs are not strong enough to pull the data bus low after a ULPI RXCMD, the Link must drive the data bus to idle after **DIR** is de-asserted.

In some cases, a Link may be software configured and not have control of its **STP** pin until after the PHY has started. In this case, the USB332x has an internal pull-up on the **STP** input pad which will pull **STP** high while the Link's **STP** output is tri-stated. The **STP** pull-up resistor is enabled on POR and can be disabled by setting the *InterfaceProtectDisable* bit 7 of the Interface Control register.

The **STP** pull-up resistor will pull-up the Link's **STP** input high until the Link configures and drives **STP** high. After the Link completes its start-up, **STP** can be synchronously driven low.

A Link design which drives **STP** high during POR can disable the pull-up resistor on **STP** by setting *InterfaceProtectDisable* bit to 1. A motivation for this is to reduce the suspend current. In Low Power Mode, **STP** is held low, which would draw current through the pull-up resistor on **STP**.

6.3.3.2 Warm Reset

Designers should also consider the case of a warm restart of a Link with a PHY in Low Power Mode. After the PHY enters Low Power Mode, **DIR** is asserted and the clock is stopped. The USB332x looks for **STP** to be asserted to re-start the clock and then resume normal synchronous operation.

Should the USB332x be suspended in Low Power Mode, and the Link receives a hardware reset, the PHY must be able to recover from Low Power Mode and start its clock. If the Link asserts **STP** on reset, the PHY will exit Low Power Mode and start its clock.

If the Link does not assert **STP** on reset, the interface protection pull-up can be used. When the Link is reset, its **STP** output will tri-state and the pull-up resistor will pull **STP** high, signaling the PHY to restart its clock.

6.3.4 Minimizing Current in Low Power Mode

In order to minimize the suspend current in Low Power Mode, the OTG comparators can be disabled to reduce suspend current. In Low Power Mode, the VbusVid and SessEnd comparators are not needed and can be disabled by clearing the associated bits in both the [USB Interrupt Enable Rising](#) and [USB Interrupt Enable Falling](#) registers. By disabling the interrupt in BOTH the rise and fall registers, the SessEnd and VbusVid comparators are turned off. The *IdFloatRise* and *IdFloatFall* bits in [Carkit Interrupt Enable](#) register should also be disabled if they were set. When exiting Low Power Mode, the Link should immediately re-enable the VbusVid and SessEnd comparators if host or OTG functionality is required.

In addition to disabling the OTG comparators in Low Power Mode, the Link may choose to disable the Interface Protect Circuit. By setting the *InterfaceProtectDisable* bit high in the [Interface Control](#) register, the Link can disable the pull-up resistor on **STP**. When **RESETB** is low the Interface Protect Circuit will be disabled.

Datasheet

6.4 Full Speed/Low Speed Serial Modes

The USB332x includes two serial modes to support legacy Links which use either the 3pin or 6pin serial format. To enter either serial mode, the Link will need to write a 1 to the *6-pin FsLsSerialMode* or the *3-pin FsLsSerialMode* bits in the Interface control register. Serial Mode may be used to conserve power when attached to a device that is not capable of operating in Hi-Speed.

The serial modes are entered in the same manner as the entry into Low Power Mode. The Link writes the Interface Control register bit for the specific serial mode. The USB332x will assert **DIR** and shut off the clock after at least five clock cycles. Then the data bus goes to the format of the serial mode selected. Before entering Serial Mode the Link must set the ULPI transceiver to the appropriate mode as defined in [Table 5.1](#).

In ULPI Clock Out Mode, the PHY will shut off the 60MHz clock to conserve power. Should the Link need the 60MHz clock to continue during the serial mode of operation, the *ClockSuspendM* bit[3] of the Interface Control Register should be set before entering a serial mode. If set, the 60 MHz clock will be present during serial modes.

In serial mode, interrupts are possible from unmasked sources. The state of each interrupt source is sampled prior to the assertion of **DIR** and this is compared against the asynchronous level from interrupt source.

Exiting the serial modes is the same as exiting Low Power Mode. The Link must assert **STP** to signal the PHY to exit serial mode. When the PHY can accept a command, **DIR** is de-asserted and the PHY will wait until the Link de-asserts **STP** to resume synchronous ULPI operation. The **RESETB** pin can also be pulsed low to reset the USB332x and return it to Synchronous Mode.

6.4.0.1 3pin FS/LS Serial Mode

Three pin serial mode utilizes the data bus pins for the serial functions shown in [Table 6.5](#).

Table 6.5 Pin Definitions in 3 pin Serial Mode

SIGNAL	CONNECTED TO	DIRECTION	DESCRIPTION
tx_enable	DATA[0]	IN	Active High transmit enable.
data	DATA[1]	I/O	TX differential data on DP/DM when tx_enable is high. RX differential data from DP/DM when tx_enable is low.
SE0	DATA[2]	I/O	TX SE0 on DP/DM when tx_enable is high. RX SE0_b from DP/DM when tx_enable is low.
interrupt	DATA[3]	OUT	Asserted when any unmasked interrupt occurs. Active high.
Reserved	DATA[7:4]	OUT	Driven Low.

6.4.0.2 6Pin FS/LS Serial Mode

Six pin serial mode utilizes the data bus pins for the serial functions shown in [Table 6.6](#).

Table 6.6 Pin Definitions in 6 pin Serial Mode

SIGNAL	CONNECTED TO	DIRECTION	DESCRIPTION
tx_enable	DATA[0]	IN	Active High transmit enable.
tx_data	DATA[1]	IN	Tx differential data on DP/DM when tx_enable is high.
tx_se0	DATA[2]	IN	Tx SE0 on DP/DM when tx_enable is high.
interrupt	DATA[3]	OUT	Asserted when any unmasked interrupt occurs. Active high.
rx_dp	DATA[4]	OUT	Single ended receive data on DP.
rx_dm	DATA[5]	OUT	Single ended receive data on DM.
rx_rcv	DATA[6]	OUT	Differential receive data from DP and DM.
Reserved	DATA[7]	OUT	Driven Low.

6.5 Carkit Mode

The USB332x includes Carkit Mode to support a USB UART and USB Audio Mode.

By entering Carkit Mode, the USB332x current drain is minimized. When operating in [ULPI Clock In Mode \(60MHz REFCLK Mode\)](#), the **CLKOUT** is stopped to conserve power by default. The Link may configure the 60MHz clock to continue by setting the *ClockSuspendM* bit of the [Interface Control](#) register before entering Carkit Mode. If set, the 60 MHz clock will continue during the Carkit Mode of operation.

In Carkit Mode, interrupts are possible if they have been enabled in the [Carkit Interrupt Enable](#) register. The state of each interrupt source is sampled prior to the assertion of **DIR** and this is compared against the asynchronous level from interrupt source. In Carkit Mode, the Linestate signals are not available per the ULPI specification.

Exiting Carkit Mode is the same as exiting Low Power Mode as described in [Section 6.3.2](#). The Link must assert **STP** to signal the PHY to exit serial mode. When the PHY can accept a command, **DIR** is de-asserted and the PHY will wait until the Link de-asserts **STP** to resume synchronous ULPI operation. The **RESETB** pin can also be pulsed low to reset the USB332x and return it to Synchronous Mode.

Datasheet

6.5.1 USB UART Mode

The USB332x can be placed into UART Mode by first setting the *TxdEn* and *RxdEn* bits in the [Carkit Control](#) register. Then the Link can set the *CarkitMode* bit in the [Interface Control](#) register. The *TxdEn* and *RxdEn* bits must be written before the *CarkitMode* bit.

Table 6.7 ULPI Register Programming Example to Enter UART Mode

R/W	ADDRESS (HEX)	VALUE (HEX)	DESCRIPTION	RESULT
W	04	49	Configure Non-Driving mode Select FS transmit edge rates	<i>OpMode</i> =01 <i>XcvrSelect</i> =01
W	39	00	Set regulator to 3.3V	<i>UART RegOutput</i> =00
W	19	0C	Enable UART connections	<i>RxdEn</i> =1 <i>TxdEn</i> =1
W	07	04	Enable carkit mode	<i>CarkitMode</i> =1

After the *CarkitMode* bit is set, the ULPI interface will become redefined as described in [Table 6.8](#), and the USB332x will transmit data through the **DATA[0]** to **DM** of the USB connector and receive data on **DP** and pass the information the Link on **DATA[1]**.

When entering UART mode, the regulator output will automatically switch to the value configured by the *UART RegOutput* bits in the [USB IO & Power Management](#) register and a pull-up will be applied internally to **DP** and **DM**. This will hold the UART in its default operating state.

While in UART mode, the transmit edge rates can be set to either the Full Speed USB or Low Speed USB edge rates by using the *XcvrSelect[1:0]* bits in the [Function Control](#) register.

Table 6.8 Pin Definitions in Carkit Mode

SIGNAL	CONNECTED TO	DIRECTION	DESCRIPTION
txd	DATA[0]	IN	UART TXD signal that is routed to the DM pin if the <i>TxdEn</i> is set in the Carkit Control register.
rxd	DATA[1]	OUT	UART RXD signal that is routed to the DP pin if the <i>RxdEn</i> bit is set in the Carkit Control register.
reserved	DATA[2]	OUT	Driven Low.
int	DATA[3]	OUT	Asserted when any unmasked interrupt occurs. Active high.
reserved	DATA[4:7]	OUT	Driven Low.

6.5.2 USB Audio Mode

When the USB332x is powered in Synchronous Mode, the Audio switches can be enabled by asserting the *SpkLeftEn*, or *SpkRightEn* bits in the [Carkit Control](#) register. After the register write is complete, the USB332x will immediately enable or disable the audio switch. Then the Link can set the *CarkitMode* bit in the [Interface Control](#) register. The *SpkLeftEn*, or *SpkRightEn* bits must be written before the *CarkitMode* bit.

Table 6.9 ULPI Register Programming Example to Enter Audio Mode

R/W	ADDRESS (HEX)	VALUE (HEX)	DESCRIPTION	RESULT
W	04	48	Configure Non-Driving mode	<i>OpMode</i> =01
W	19	30	Enable Audio connections	<i>SpkrRightEn</i> =1, <i>SpkrLeftEn</i> =1
W	07	04	Enable carkit mode	<i>CarkitMode</i> =1

After the *CarkitMode* bit is set, the ULPI interface will become redefined as described in [Table 6.8](#).

6.6 RID Converter Operation

The RID converter is designed to read the value of the ID resistance to ground and report back its value through the ULPI interface.

When a resistor to ground is applied to the **ID** pin the state of the IdGnd comparator will change from a 1 to a 0 as described in [Section 5.6.1](#). If the USB332x is in ULPI mode, an RXCMD will be generated with bit 6 low. If the USB332x is in Low Power Mode (or one of the other non-ULPI modes), the DATA[3] interrupt signal will go high.

After the USB332x has detected the change of state on the **ID** pin, the RID converter can be used to determine the value of ID resistance. To start a ID resistance measurement, the *RidConversionStart* bit is set in the [Vendor Rid Conversion](#) register.

The Link can use one of two methods to determine when the RID Conversion is complete. One method is polling the *RidConversionStart* bit as described in [Section 7.1.3.3](#). The preferred method is to set the *RidIntEn* bit in the [Vendor Rid Conversion](#) register. When *RidIntEn* is set, an RXCMD will be generated after the RID conversion is complete. As described in [Table 6.3](#), the *alt_int* bit of the RXCMD will be set.

After the RID Conversion is complete, the Link can read *RidValue* from the [Vendor Rid Conversion](#) register.

6.7 Headset Audio Mode

This mode is designed to allow a user to view the status of several signals while using an analog audio headset with a USB connector. This feature, exclusive to SMSC, is provided as an alternate mode to the CarKit Mode defined in [Section 6.5](#). In the CarKit Mode, the Link is unable to view the source of the interrupt on **ID**, except by returning to synchronous mode to read the ULPI registers. This forces the audio switches to be deactivated, and may glitch the audio signals. In addition, the Link cannot change the resistance on the **ID** pin without starting up the PHY to access the ULPI registers.

The Headset Audio Mode is entered by writing to the [Headset Audio Mode](#) register, and allows the Link access to the state of the **VBUS** and **ID** pins during audio without glitching the audio connection. The Headset Audio mode also enables the Link to change the resistance on the **ID** pin and to change the audio headset attached from mono to stereo.

Datasheet

The ULPI interface is redefined as shown in [Table 6.10](#) when Headset Audio Mode is entered.

Table 6.10 Pin Definitions in Headset Audio Mode

SIGNAL	CONNECTED TO	DIRECTION	DESCRIPTION
SessVId	DATA[0]	OUT	Output of SessVId comparator
VbusVId	DATA[1]	OUT	Output of VbusVId Comparator (interrupt must be enabled)
IdGndDrv	DATA[2]	IN	Drives ID pin to ground when asserted 0b: Not connected 1b: Connects ID to ground.
	DATA[3]	OUT	Driven low
IdGround	DATA[4]	OUT	Asserted when the ID pin is grounded. 0b: ID pin is grounded 1b: ID pin is floating
IdFloat	DATA[5]	OUT	Asserted when the ID pin is floating. <i>IdPullup</i> or <i>d_pullup330</i> must be enabled as shown below.
IdPullup330	DATA[6]	IN	When enabled a 330kΩ pullup is applied to the ID pin. This bit will also change the trip point of the IdGnd comparator to the value shown in Table 4.7 . 0b: Disables the pull-up resistor 1b: Enables the pull-up resistor
IdPullup	DATA[7]	IN	Connects the 100kΩ pull-up resistor from the ID pin to VDD3.3 0b: Disables the pull-up resistor 1b: Enables the pull-up resistor

Exiting Headset Audio Mode is the same as exiting Low Power Mode as described in [Section 6.3.2](#). The Link must assert **STP** to signal the PHY to exit. When the PHY can accept a command, **DIR** is de-asserted and the PHY will wait until the Link de-asserts **STP** to resume synchronous ULPI operation. The **RESETB** pin can also be pulsed low to reset the USB332x and return it to Synchronous Mode.

Chapter 7 ULPI Register Map

7.1 ULPI Register Array

The USB332x PHY implements all of the ULPI registers detailed in the ULPI revision 1.1 specification. The complete USB332x ULPI register set is shown in [Table 7.1](#). All registers are 8 bits. This table also includes the default state of each register upon POR or de-assertion of **RESETB**, as described in [Section 5.5.2](#). The RESET bit in the [Function Control](#) Register does not reset the bits of the ULPI register array. The Link should not read or write to any registers not listed in this table.

The USB332x supports extended register access. The immediate register set (00-3Fh) can be accessed through either a immediate address or an extended register address.

Table 7.1 ULPI Register Map

REGISTER NAME	DEFAULT STATE	ADDRESS (6BIT)			
		READ	WRITE	SET	CLEAR
Vendor ID Low	24h	00h	-	-	-
Vendor ID High	04h	01h	-	-	-
Product ID Low	07h	02h	-	-	-
Product ID High	00h	03h	-	-	-
Function Control	41h	04-06h	04h	05h	06h
Interface Control	00h	07-09h	07h	08h	09h
OTG Control	06h	0A-0Ch	0Ah	0Bh	0Ch
USB Interrupt Enable Rising	1Fh	0D-0Fh	0Dh	0Eh	0Fh
USB Interrupt Enable Falling	1Fh	10-12h	10h	11h	12h
USB Interrupt Status (Note 7.1)	00h	13h	-	-	-
USB Interrupt Latch	00h	14h	-	-	-
Debug	00h	15h	-	-	-
Scratch Register	00h	16-18h	16h	17h	18h
Carkit Control	00h	19-1Bh	19h	1Ah	1Bh
Reserved	00h	1Ch			
Carkit Interrupt Enable	00h	1D-1Fh	1Dh	1Eh	1Fh
Carkit Interrupt Status	00h	20h	-	-	-
Carkit Interrupt Latch	00h	21h	-	-	-
Reserved	00h	22-30h			
HS TX Boost	00h	31h	31h	-	-
Reserved	00h	32h	32h	-	-
Headset Audio Mode	00h	33h	33h	-	-

Datasheet

Table 7.1 ULPI Register Map (continued)

REGISTER NAME	DEFAULT STATE	ADDRESS (6BIT)			
		READ	WRITE	SET	CLEAR
Reserved	00h	34-35h			
Vendor Rid Conversion	00h	36-38h	36h	37h	38h
USB IO & Power Management	04h	39-3Bh	39h	3Ah	3Bh
Reserved	00h	3C-3Fh			

Note 7.1 Dynamically updates to reflect current status of interrupt sources.

7.1.1 ULPI Register Set

The following registers are used for the ULPI interface.

7.1.1.1 Vendor ID Low

Address = 00h (read only)

FIELD NAME	BIT	ACCESS	DEFAULT	DESCRIPTION
<i>Vendor ID Low</i>	7:0	rd	24h	SMSC Vendor ID

7.1.1.2 Vendor ID High

Address = 01h (read only)

FIELD NAME	BIT	ACCESS	DEFAULT	DESCRIPTION
<i>Vendor ID High</i>	7:0	rd	04h	SMSC Vendor ID

7.1.1.3 Product ID Low

Address = 02h (read only)

FIELD NAME	BIT	ACCESS	DEFAULT	DESCRIPTION
<i>Product ID Low</i>	7:0	rd	07h	SMSC Product ID

7.1.1.4 Product ID High

Address = 03h (read only)

FIELD NAME	BIT	ACCESS	DEFAULT	DESCRIPTION
<i>Product ID High</i>	7:0	rd	00h	SMSC Product ID

7.1.1.5 Function Control

Address = 04-06h (read), 04h (write), 05h (set), 06h (clear)

FIELD NAME	BIT	ACCESS	DEFAULT	DESCRIPTION
<i>XcvrSelect[1:0]</i>	1:0	rd/w/s/c	01b	Selects the required transceiver speed. 00b: Enables HS transceiver 01b: Enables FS transceiver 10b: Enables LS transceiver 11b: Enables FS transceiver for LS packets (FS preamble automatically pre-pended)
<i>TermSelect</i>	2	rd/w/s/c	0b	Controls the DP and DM termination depending on <i>XcvrSelect</i> , <i>OpMode</i> , <i>DpPulldown</i> , and <i>DmPulldown</i> . The DP and DM termination is detailed in Table 5.1 .
<i>OpMode</i>	4:3	rd/w/s/c	00b	Selects the required bit encoding style during transmit. 00b: Normal Operation 01b: Non-Driving 10b: Disable bit-stuff and NRZI encoding 11b: Reserved
<i>Reset</i>	5	rd/w/s/c	0b	Active high transceiver reset. This reset does not reset the ULPI interface or register set. Automatically clears after reset is complete.
<i>SuspendM</i>	6	rd/w/s/c	1b	Active low PHY suspend. When cleared the PHY will enter Low Power Mode as detailed in 6.3 . Automatically set when exiting Low Power Mode.
<i>Reserved</i>	7	rd	0b	Read only, 0.

7.1.1.6 Interface Control

Address = 07-09h (read), 07h (write), 08h (set), 09h (clear)

FIELD NAME	BIT	ACCESS	DEFAULT	DESCRIPTION
<i>6-pin FsLsSerialMode</i>	0	rd/w/s/c	0b	When asserted the ULPI interface is redefined to the 6-pin Serial Mode. The PHY will automatically clear this bit when exiting serial mode.
<i>3-pin FsLsSerialMode</i>	1	rd/w/s/c	0b	When asserted the ULPI interface is redefined to the 3-pin Serial Mode. The PHY will automatically clear this bit when exiting serial mode.
<i>CarkitMode</i>	2	rd/w/s/c	0b	When asserted the ULPI interface is redefined to the Carkit interface. The PHY will automatically clear this bit when exiting Carkit Mode.

Datasheet

FIELD NAME	BIT	ACCESS	DEFAULT	DESCRIPTION
<i>ClockSuspendM</i>	3	rd/w/s/c	0b	Enables Link to turn on 60MHz CLKOUT in Serial Mode or CarKit Mode. 0b: Disable clock in serial or CarKit Mode. 1b: Enable clock in serial or CarKit Mode.
<i>AutoResume</i>	4	rd/w/s/c	0b	Only applicable in Host mode. Enables the PHY to automatically transmit resume signaling. This function is detailed in Section 6.2.4.4 .
<i>IndicatorComplement</i>	5	rd/w/s/c	0b	Inverts the EXTVBUS signal. This function is detailed in Section 5.6.2 . Note: The EXTVBUS signal is always high on the USB332x.
<i>IndicatorPassThru</i>	6	rd/w/s/c	0b	Disables and'ing the internal VBUS comparator with the EXTVBUS signal when asserted. This function is detailed in Section 5.6.2 . Note: The EXTVBUS signal is always high on the USB332x.
<i>InterfaceProtectDisable</i>	7	rd/w/s/c	0b	Used to disable the integrated STP pull-up resistor used for interface protection. This function is detailed in Section 6.3.3 .

7.1.1.7 OTG Control

Address = 0A-0Ch (read), 0Ah (write), 0Bh (set), 0Ch (clear)

FIELD NAME	BIT	ACCESS	DEFAULT	DESCRIPTION
<i>IdPullup</i>	0	rd/w/s/c	0b	Connects a 100kΩ pull-up resistor from the ID pin to VDD33 0b: Disables the pull-up resistor 1b: Enables the pull-up resistor
<i>DpPulldown</i>	1	rd/w/s/c	1b	Enables the 15k Ohm pull-down resistor on DP . 0b: Pull-down resistor not connected 1b: Pull-down resistor connected
<i>DmPulldown</i>	2	rd/w/s/c	1b	Enables the 15k Ohm pull-down resistor on DM . 0b: Pull-down resistor not connected 1b: Pull-down resistor connected
<i>DischrgVbus</i>	3	rd/w/s/c	0b	This bit is only used during SRP. Connects a resistor from VBUS to ground to discharge VBUS . 0b: disconnect resistor from VBUS to ground 1b: connect resistor from VBUS to ground
<i>ChrgVbus</i>	4	rd/w/s/c	0b	This bit is only used during SRP. Connects a resistor from VBUS to VDD33 to charge VBUS above the SessValid threshold. 0b: disconnect resistor from VBUS to VDD33 1b: connect resistor from VBUS to VDD33
<i>DrvVbus</i>	5	rd/w/s/c	0b	Not Implemented.
<i>DrvVbusExternal</i>	6	rd/w/s/c	0b	Not Implemented.

FIELD NAME	BIT	ACCESS	DEFAULT	DESCRIPTION
<i>UseExternalVbus Indicator</i>	7	rd/w/s/c	0b	Tells the PHY to use an external VBUS over-current or voltage indicator. This function is detailed in Section 5.6.2 . 0b: Use the internal VbusValid comparator 1b: Use the EXTVBUS input as for VbusValid signal. Note: The EXTVBUS signal is always high on the USB332x.

7.1.1.8 USB Interrupt Enable Rising

Address = 0D-0Fh (read), 0Dh (write), 0Eh (set), 0Fh (clear)

FIELD NAME	BIT	ACCESS	DEFAULT	DESCRIPTION
<i>HostDisconnect Rise</i>	0	rd/w/s/c	1b	Generate an interrupt event notification when Hostdisconnect changes from low to high. Applicable only in host mode.
<i>VbusValid Rise</i>	1	rd/w/s/c	1b	Generate an interrupt event notification when Vbusvalid changes from low to high.
<i>SessValid Rise</i>	2	rd/w/s/c	1b	Generate an interrupt event notification when SessValid changes from low to high.
<i>SessEnd Rise</i>	3	rd/w/s/c	1b	Generate an interrupt event notification when SessEnd changes from low to high.
<i>IdGnd Rise</i>	4	rd/w/s/c	1b	Generate an interrupt event notification when IdGnd changes from low to high.
<i>Reserved</i>	7:5	rd	0h	Read only, 0.

7.1.1.9 USB Interrupt Enable Falling

Address = 10-12h (read), 10h (write), 11h (set), 12h (clear)

FIELD NAME	BIT	ACCESS	DEFAULT	DESCRIPTION
<i>HostDisconnect Fall</i>	0	rd/w/s/c	1b	Generate an interrupt event notification when Hostdisconnect changes from high to low. Applicable only in host mode.
<i>VbusValid Fall</i>	1	rd/w/s/c	1b	Generate an interrupt event notification when Vbusvalid changes from high to low.
<i>SessValid Fall</i>	2	rd/w/s/c	1b	Generate an interrupt event notification when SessValid changes from high to low.
<i>SessEnd Fall</i>	3	rd/w/s/c	1b	Generate an interrupt event notification when SessEnd changes from high to low.
<i>IdGnd Fall</i>	4	rd/w/s/c	1b	Generate an interrupt event notification when IdGnd changes from high to low.
<i>Reserved</i>	7:5	rd	0h	Read only, 0.

Datasheet

7.1.1.10 USB Interrupt Status

Address = 13h (read only)

This register dynamically updates to reflect current status of interrupt sources.

FIELD NAME	BIT	ACCESS	DEFAULT	DESCRIPTION
<i>HostDisconnect</i>	0	rd	0b	Current value of the UTMI+ Hi-Speed Hostdisconnect output. Applicable only in host mode.
<i>VbusValid</i>	1	rd	0b	Current value of the UTMI+ Vbusvalid output.
<i>SessValid</i>	2	rd	0b	Current value of the UTMI+ SessValid output.
<i>SessEnd</i>	3	rd	0b	Current value of the UTMI+ SessEnd output.
<i>IdGnd</i>	4	rd	0b	Current value of the UTMI+ IdGnd output.
<i>Reserved</i>	7:5	rd	0h	Read only, 0.

Note: The default conditions will match the current status of the comparators. The values shown are for an unattached OTG device.

7.1.1.11 USB Interrupt Latch

Address = 14h (read only with auto clear)

FIELD NAME	BIT	ACCESS	DEFAULT	DESCRIPTION
<i>HostDisconnect Latch</i>	0	rd (Note 7.2)	0b	Set to 1b by the PHY when an unmasked event occurs on Hostdisconnect. Cleared when this register is read. Applicable only in host mode.
<i>VbusValid Latch</i>	1	rd (Note 7.2)	0b	Set to 1b by the PHY when an unmasked event occurs on VbusValid. Cleared when this register is read.
<i>SessValid Latch</i>	2	rd (Note 7.2)	0b	Set to 1b by the PHY when an unmasked event occurs on SessValid. Cleared when this register is read.
<i>SessEnd Latch</i>	3	rd (Note 7.2)	0b	Set to 1b by the PHY when an unmasked event occurs on SessEnd. Cleared when this register is read.
<i>IdGnd Latch</i>	4	rd (Note 7.2)	0b	Set to 1b by the PHY when an unmasked event occurs on IdGnd. Cleared when this register is read.
<i>Reserved</i>	7:5	rd	0h	Read only, 0.

Note 7.2 rd: Read Only with auto clear.

7.1.1.12 Debug

Address = 15h (read only)

FIELD NAME	BIT	ACCESS	DEFAULT	DESCRIPTION
<i>Linestate0</i>	0	rd	0b	Contains the current value of Linestate[0].
<i>Linestate1</i>	1	rd	0b	Contains the current value of Linestate[1].
<i>Reserved</i>	7:2	rd	000000b	Read only, 0.

7.1.1.13 Scratch Register

Address = 16-18h (read), 16h (write), 17h (set), 18h (clear)

FIELD NAME	BIT	ACCESS	DEFAULT	DESCRIPTION
<i>Scratch</i>	7:0	rd/w/s/c	00h	Empty register byte for testing purposes. Software can read, write, set, and clear this register and the PHY functionality will not be affected.

7.1.2 Carkit Control Registers

The following registers are used to set-up and enable the USB UART and USB Audio functions.

7.1.2.1 Carkit Control

Address = 19-1Bh (read), 19h (write), 1Ah (set), 1Bh (clear)

This register is used to program the USB332x into and out of the Carkit Mode. When entering the UART mode the Link must first set the desired *TxdEn* and the *RxdEn* bits and then transition to Carkit Mode by setting the *CarkitMode* bit in the [Interface Control](#) Register. When *RxdEn* is not set then the **DATA[1]** pin is held to a logic high.

FIELD NAME	BIT	ACCESS	DEFAULT	DESCRIPTION
<i>CarkitPwr</i>	0	rd	0b	Read only, 0.
<i>IdGndDrv</i>	1	rd/w/s/c	0b	Drives ID pin to ground
<i>TxdEn</i>	2	rd/w/s/c	0b	Connects UART TXD (DATA[0]) to DM
<i>RxdEn</i>	3	rd/w/s/c	0b	Connects UART RXD (DATA[1]) to DP
<i>SpkLeftEn</i>	4	rd/w/s/c	0b	Connects DM pin to SPK_L pin
<i>SpkRightEn</i>	5	rd/w/s/c	0b	Connects DP pin to SPK_R pin. See Note below.
<i>MicEn</i>	6	rd/w/s/c	0b	Connects DP pin to SPK_R pin. See Note below.
<i>Reserved</i>	7	rd	0b	Read only, 0.

Note: If *SpkRightEn* or *MicEn* are asserted the **DP** pin will be connected to **SPK_R**. To disconnect the **DP** pin from the **SPK_R** pin both *SpkrRightEn* and *MicEn* must be set to de-asserted.

Datasheet

If using USB UART mode the UART data will appear at the **SPK_L** and **SPK_R** pins if the corresponding *SpkLeftEn*, *SpkRightEn*, or *MicEn* switches are enabled.

If using USB Audio the *TxdEn* and *RxdEn* bits should not be set when the *SpkLeftEn*, *SpkRightEn*, or *MicEn* switches are enabled. The USB single-ended receivers described in [Section 5.2.1](#) are disabled when either *SpkLeftEn*, *SpkRightEn*, or *MicEn* are set.

7.1.2.2 Carkit Interrupt Enable

Address = 1D-1Fh (read), 1Dh (write), 1Eh (set), 1Fh (clear)

FIELD NAME	BIT	ACCESS	DEFAULT	DESCRIPTION
<i>IdFloatRise</i>	0	rd/w/s/c	0b	When enabled an interrupt will be generated on the alt_int of the RXCMD byte when the ID pin transitions from non-floating to floating. The <i>IdPullup</i> bit in the OTG Control register should be set.
<i>IdFloatFall</i>	1	rd/w/s/c	0b	When enabled an interrupt will be generated on the alt_int of the RXCMD byte when the ID pin transitions from floating to non-floating. The <i>IdPullup</i> bit in the OTG Control register should be set.
<i>CarIntDet</i>	2	rd	0b	Not Implemented. Reads as 0b.
<i>CarDpRise</i>	3	rd	0b	Not Implemented. Reads as 0b.
<i>CarDpFall</i>	4	rd	0b	Not Implemented. Reads as 0b.
<i>RidIntEn</i>	5	rd/w/s/c	0b	When enabled an interrupt will be generated on the alt_int of the RXCMD byte when <i>RidConversionDone</i> bit is asserted. Note: This register bit is or'ed with the <i>RidIntEn</i> bit of the Vendor Rid Conversion register described in Section 7.1.3.3 .
<i>Reserved</i>	7:6	rd	0b	Read only, 0.

7.1.2.3 Carkit Interrupt Status

Address = 20h (read only)

FIELD NAME	BIT	ACCESS	DEFAULT	DESCRIPTION
<i>IdFloat</i>	0	rd	0b	Asserted when the ID pin is floating. <i>IdPullup</i> must be enabled.
<i>CarIntDet</i>	1	rd	0b	Not Implemented. Reads as 0b.
<i>CarDp</i>	2	rd	0b	Not Implemented. Reads as 0b.

FIELD NAME	BIT	ACCESS	DEFAULT	DESCRIPTION
<i>RidValue</i>	5:3	rd	000b	Conversion value of Rid resistor 000: 0 ohms 001: 75 ohms 010: 102K ohms 011: 200K ohms 100: 440K ohms 101: ID floating 111: Error Note: <i>RidValue</i> can also be read from the Vendor Rid Conversion register described in Section 7.1.3.3 .
<i>RidConversionDone</i>	6	rd	0b	Automatically asserted by the USB332x when the Rid Conversion is finished. The conversion will take 282uS. This bit will auto clear when the <i>RidValue</i> is read from the Rid Conversion Register. Reading the <i>RidValue</i> from the Carkit Interrupt Status register will not clear either <i>RidConversionDone</i> status bit. Note: <i>RidConversionDone</i> can also be read from the Vendor Rid Conversion register described in Section 7.1.3.3 .
<i>Reserved</i>	7	rd	0b	Read only, 0.

7.1.2.4 Carkit Interrupt Latch

Address = 21h (read only with auto-clear)

FIELD NAME	BIT	ACCESS	DEFAULT	DESCRIPTION
<i>IdFloat Latch</i>	0	rd (Note 7.3)	0b	Asserted if the state of the ID pin changes from non-floating to floating while the <i>IdFloatRise</i> bit is enabled or if the state of the ID pin changes from floating to non-floating while the <i>IdFloatFall</i> bit is enabled.
<i>CarIntDet Latch</i>	1	rd	0b	Not Implemented. Reads as 0b.
<i>CarDp Latch</i>	2	rd	0b	Not Implemented. Reads as 0b.
<i>RidConversionLatch</i>	3	rd (Note 7.3)	0b	If <i>RidIntEn</i> is set and the state of the <i>RidConversionDone</i> bit changes from a 0 to 1 this bit will be asserted.
<i>Reserved</i>		rd	00000b	Read only, 0.

Note 7.3 rd: Read Only with auto clear

7.1.3 Vendor Register Access

The vendor specific registers include the range from 30h to 3Fh. These can be accessed by the ULPI immediate register read / write.

Datasheet

7.1.3.1 HS TX Boost

Address = 31h (read / write)

FIELD NAME	BIT	ACCESS	DEFAULT	DESCRIPTION
<i>Reserved</i>	0	rd	0b	Read only, 0.
<i>Reserved</i>	1	rd	0b	Read only, 0.
<i>Reserved</i>	2	rd	0b	Read only, 0.
<i>Reserved</i>	3	rd	0b	Read only, 0.
<i>Reserved</i>	4	rd	0b	Read only, 0.
<i>Boost</i>	6:5	rd/w	00b	Sets the HS transmitter amplitude as described in Section 5.2.1 . 00b: Nominal 01b: Enables 11.1% increased drive strength 10b: Enables 7.4% increased drive strength 11b: Enables 3.7% increased drive strength
<i>Reserved</i>	7	rd	0b	Read only, 0.

7.1.3.2 Headset Audio Mode

Address = 33h (read / write)

FIELD NAME	BIT	ACCESS	DEFAULT	DESCRIPTION
<i>HeadsetAudioEn</i>	3:0	rd/w	0000b	When this field is set to a value of 1010, the Headset Audio Mode is enabled as described in Section 6.7 .
<i>Reserved</i>	7:4	rd	0h	Read only, 0.

7.1.3.3 Vendor Rid Conversion

Address = 36-38h (read), 36h (write), 37h (set), 38h (clear)

FIELD NAME	BIT	ACCESS	DEFAULT	DESCRIPTION
<i>RidValue</i>	2:0	rd/w	000b	Conversion value of Rid resistor 000: 0 ohms 001: 75 ohms 010: 100K ohms 011: 200K ohms 100: 440K ohms 101: ID floating 111: Error Note: <i>RidValue</i> can also be read from the Carkit Interrupt Status Register.

FIELD NAME	BIT	ACCESS	DEFAULT	DESCRIPTION
<i>RidConversionDone</i>	3	rd (Note 7.4)	0b	Automatically asserted by the USB332x when the Rid Conversion is finished. The conversion will take 282uS. This bit will auto clear when the <i>RidValue</i> is read from the Rid Conversion Register. Reading the <i>RidValue</i> from the Carkit Interrupt Status Register will not clear either <i>RidConversionDone</i> status bit. Note: <i>RidConversionDone</i> can also be read from the Carkit Interrupt Status Register.
<i>RidConversionStart</i>	4	rd/w/s/c	0b	When this bit is asserted either through a register write or set, the Rid converter will read the value of the ID resistor. When the conversion is complete this bit will auto clear.
<i>Reserved</i>	5	rd/w/s/c	0b	This bit must remain at 0.
<i>RidIntEn</i>	6	rd/w/s/c	0b	When enabled an interrupt will be generated on the <i>alt_int</i> of the RXCMD byte when <i>RidConversionDone</i> bit is asserted. Note: This register bit is or'ed with the <i>RidIntEn</i> bit of the Carkit Interrupt Status register.
<i>Reserved</i>	7	rd	0b	Read only, 0.

Note 7.4 rd: Read Only with auto clear.

7.1.3.4 USB IO & Power Management

Address = 39-3Bh (read), 39h (write), 3Ah (set), 3Bh (clear)

FIELD NAME	BIT	ACCESS	DEFAULT	DESCRIPTION
<i>Reserved</i>	0	rd/w/s/c	0b	Read only, 0.
<i>SwapDP/DM</i>	1	rd/w/s/c	0b	When asserted, the DP and DM pins of the USB PHY are swapped. This bit can be used to prevent crossing the DP/DM traces on the board. In UART mode, it swaps the routing to the DP and DM pins. In USB Audio Mode, it does not affect the SPK_L and SPK_R pins.
<i>UART RegOutput</i>	3:2	rd/w/s/c	01b	Controls the output voltage of the VBAT to VDD33 regulator in UART mode. When the PHY is switched from USB mode to UART mode regulator output will automatically change to the value specified in this register when <i>TxdEn</i> is asserted. 00: 3.3V 01: 3.0V (default) 10: 2.75V 11: 2.5V Note: When in USB Audio Mode the regulator will remain at 3.3V. When using this register it is recommended that the Link exit UART mode by using the RESETB pin.
<i>ChargerPullupEnDP</i>	4	rd/w/s/c	0b	Enables a Pull-up for USB Charger Detection when set on the DP pin. (The pull-up is automatically enabled in UART mode)

Datasheet

FIELD NAME	BIT	ACCESS	DEFAULT	DESCRIPTION
<i>ChargerPullupEnDM</i>	5	rd/w/s/c	0b	Enables a Pull-up for USB Charger Detection when set on the DM pin. (The pull-up is automatically enabled in UART mode)
<i>USB RegOutput</i>	7:6	rd/w/s/c	00b	Controls the output voltage of the VBAT to VDD33 regulator in USB mode. When the PHY is in Synchronous Mode, Serial Mode, or Low Power Mode, the regulator output will be the value specified in this register. 00: 3.3V (default) 01: 3.0V 10: 2.75V 11: 2.5V

Chapter 8 Application Notes

8.1 Application Diagram

The USB332x requires few external components as shown in the application diagrams. The USB 2.0 Specification restricts the voltage at the VBUS pin to a maximum value of 5.25V. In some applications, the voltage will exceed this voltage, so the USB332x provides an integrated overvoltage protection circuit. The overvoltage protection circuit works with an external resistor (R_{VBUS}) to lower the voltage at the **VBUS** pin.

Following POR or hardware reset, the voltage at **CLKOUT** must not exceed V_{IH_ED} as provided in [Table 4.4](#).

Table 8.1 Component Values in Application Diagrams

REFERENCE DESIGNATOR	VALUE	DESCRIPTION	NOTES
C_{OUT}	2.2 μ F	Bypass capacitor to ground (<1 Ω ESR) for regulator stability.	Place as close as possible to the PHY.
C_{VBUS}	See Table 8.2	Capacitor to ground required by the USB Specification. SMSC recommends <1 Ω ESR.	Place near the USB connector.
C_{BYP}	System dependent.	Bypass capacitor to ground. Typical values used are 0.1 or 0.01 μ F.	Place as close as possible to the PHY.
C_{DC_LOAD}	System dependent.	The USB connector housing may be AC-coupled to the device ground.	Industry convention is to ground only the host side of the cable shield.
R_{VBUS}	1k Ω or 10k Ω	Series resistor to work with internal overvoltage protection. 10k Ω in device applications. See Table 5.6 for required values in Host or OTG applications.	See Section 5.6.2.6 for information regarding power dissipation.
R_{BIAS}	8.06k Ω (\pm 1%)	Series resistor to establish reference voltage.	See Section 5.3 for information regarding power dissipation.

Table 8.2 Capacitance Values at VBUS of USB Connector

MODE	MIN VALUE	MAX VALUE
Host	120 μ F	
Device	1 μ F	10 μ F
OTG	1 μ F	6.5 μ F

Datasheet

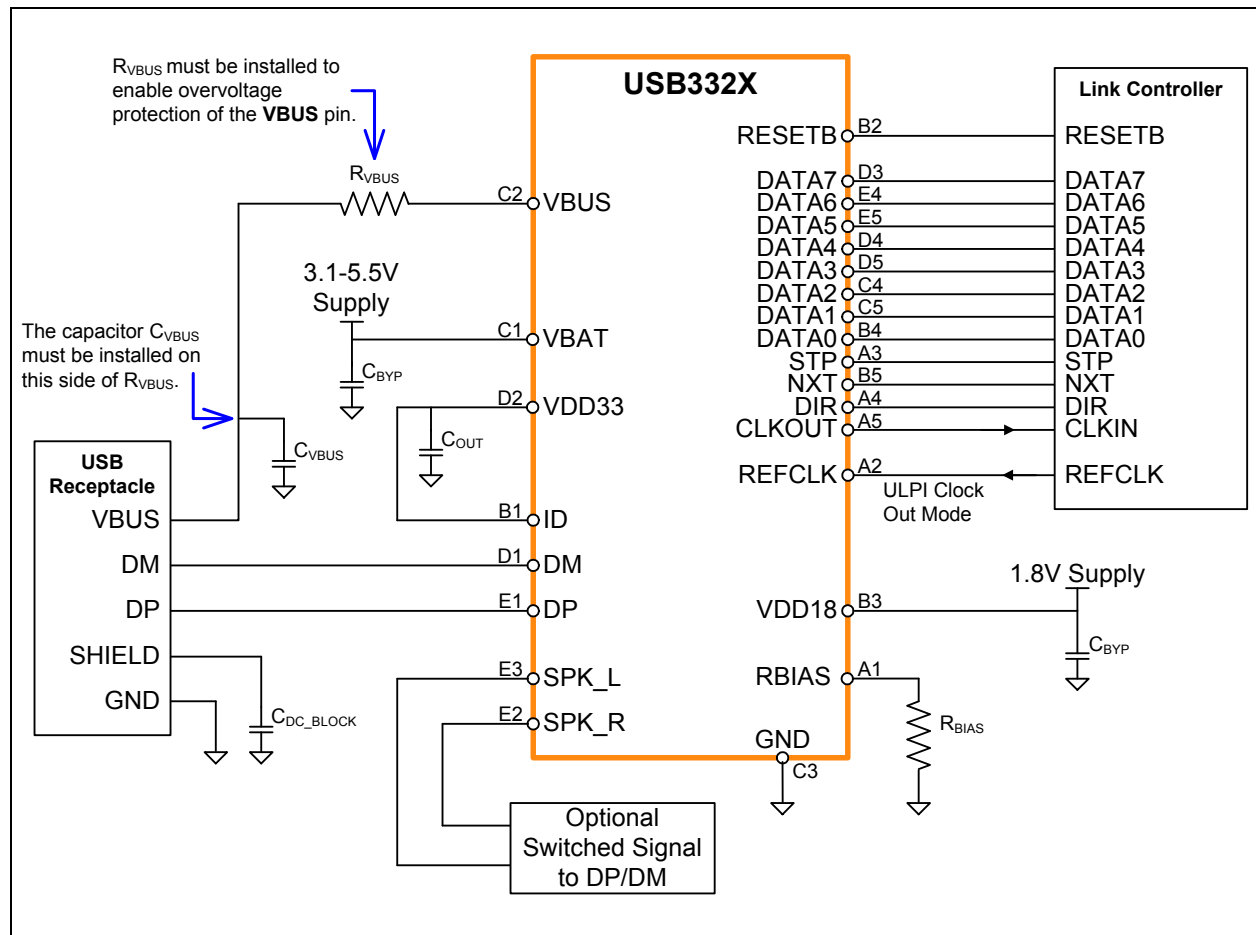

Figure 8.1 USB332x WLCSP Application Diagram (Device configured for ULPI Clock Out mode)

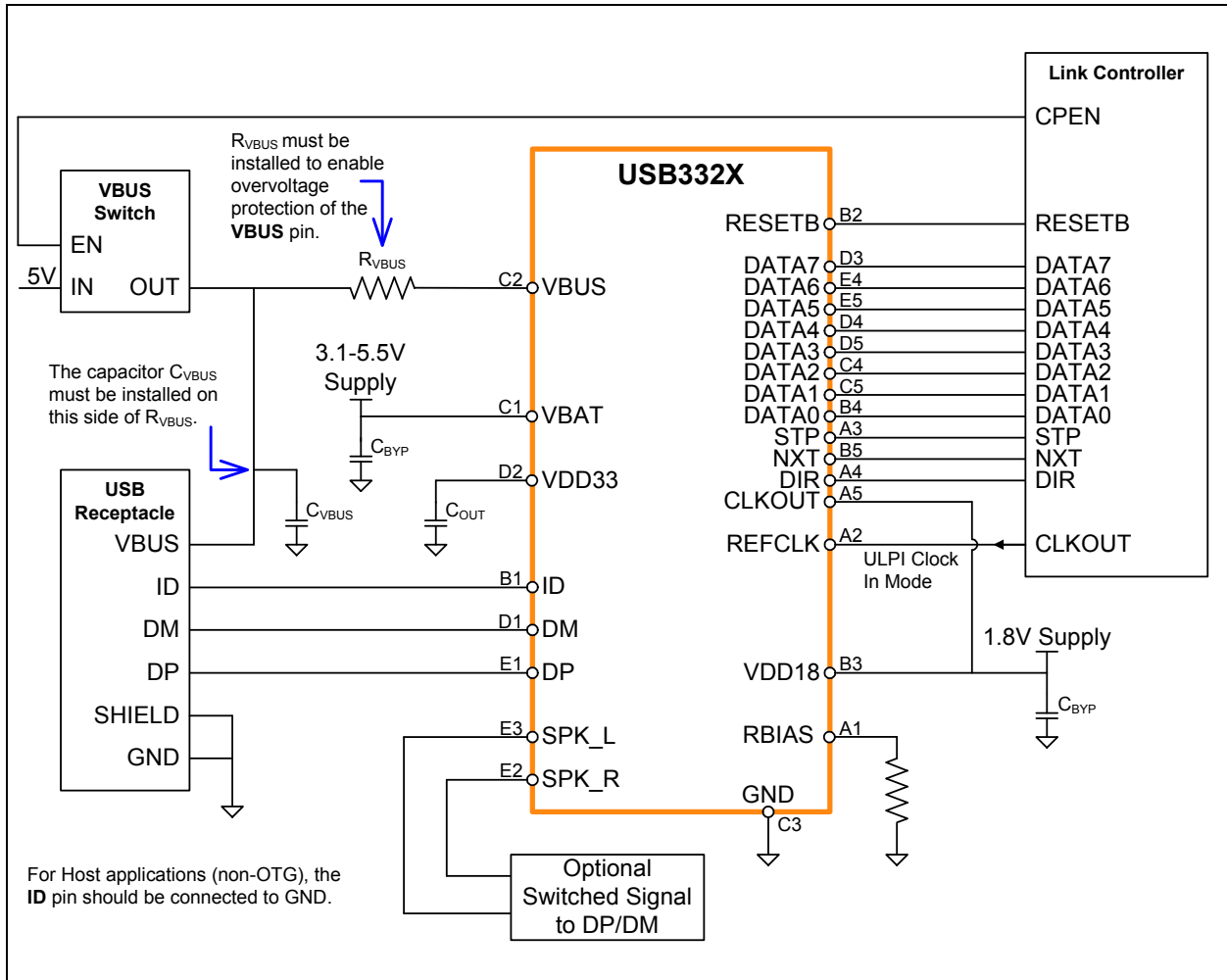

Figure 8.2 USB332x WLCSP Application Diagram (Host or OTG configured for ULPI Clock In mode)

8.2 Reference Designs

SMSC has generated reference designs for connecting the USB332x to SOCs with a ULPI port. Please contact the SMSC sales office for more details.

8.3 ESD Performance

The USB332x is protected from ESD strikes. By eliminating the requirement for external ESD protection devices, board space is conserved, and the board manufacturer is enabled to reduce cost. The advanced ESD structures integrated into the USB332x protect the device whether or not it is powered up.

8.3.1 Human Body Model (HBM) Performance

HBM testing verifies the ability to withstand the ESD strikes like those that occur during handling and manufacturing, and is done without power applied to the IC. To pass the test, the device must have no change in operation or performance due to the event. All pins on the USB332x except the REFCLK, SPK_L, and SPK_R pins provide ±8kV HBM protection, as shown in Table 4.10.

Datasheet

8.3.2 EN/IEC 61000-4-2 Performance

The EN/IEC 61000-4-2 ESD specification is an international standard that addresses system-level immunity to ESD strikes while the end equipment is operational. In contrast, the HBM ESD tests are performed at the device level with the device powered down.

SMSC contracts with Independent laboratories to test the USB332x to EN/IEC 61000-4-2 in a working system. Reports are available upon request. Please contact your SMSC representative, and request information on 3rd party ESD test results. The reports show that systems designed with the USB332x can safely provide the ESD performance shown in [Table 4.10](#) without additional board level protection.

In addition to defining the ESD tests, EN/IEC 61000-4-2 also categorizes the impact to equipment operation when the strike occurs (ESD Result Classification). The USB332x maintains an ESD Result Classification 1 or 2 when subjected to an EN/IEC 61000-4-2 (level 4) ESD strike.

Both air discharge and contact discharge test techniques for applying stress conditions are defined by the EN/IEC 61000-4-2 ESD document.

8.3.3 Air Discharge

To perform this test, a charged electrode is moved close to the system being tested until a spark is generated. This test is difficult to reproduce because the discharge is influenced by such factors as humidity, the speed of approach of the electrode, and construction of the test equipment.

8.3.4 Contact Discharge

The uncharged electrode first contacts the USB connector to prepare this test, and then the probe tip is energized. This yields more repeatable results, and is the preferred test method. The independent test laboratories contracted by SMSC provide test results for both types of discharge methods.

Chapter 9 Package Outline, Tape & Reel Drawings, Package Ma

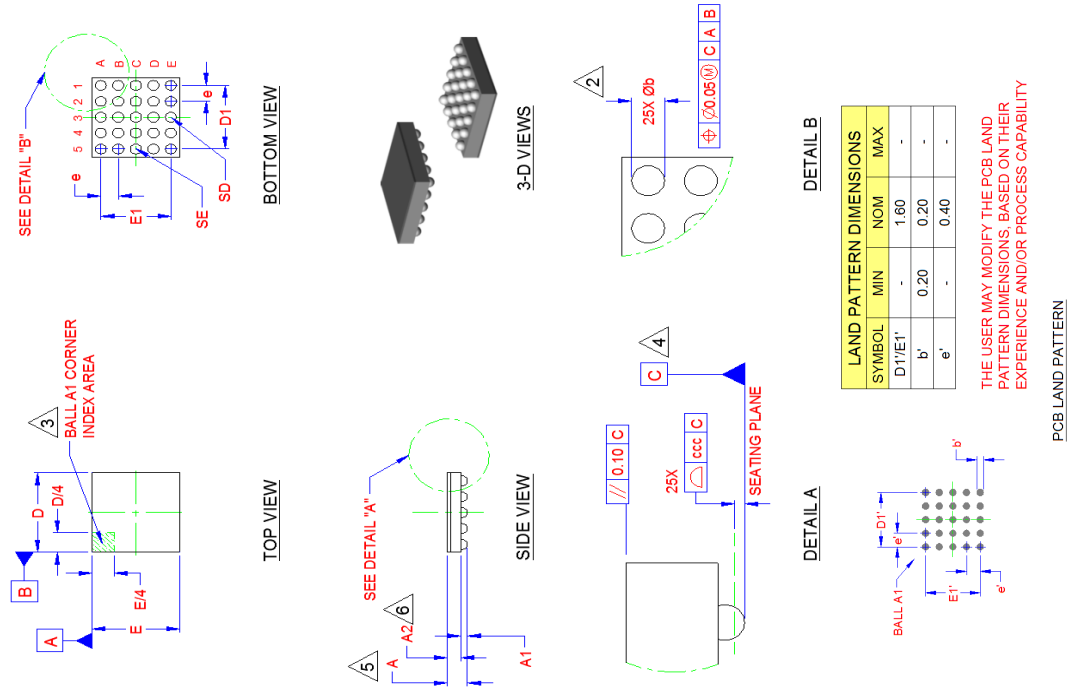

COMMON DIMENSIONS					
SYMBOL	MIN	NOM	MAX	NOTE	REM
A	0.52	-	0.62	5	OVERALL PAC
A1	0.16	-	0.24	-	STAN
A2	-	-	0.38	6	PACKAGE
D/E	1.94	1.97	2.00	-	XY D
D1/E1	1.60 BSC		-	-	XY END BAL
b	0.20	0.25	0.30	2	BALL D
e	0.40 BSC		-	-	BALL
SD/SE	0.00		-	-	CENTER BALL PC
ccc	0	-	0.05	4	COPLA

NOTES:

1. ALL DIMENSIONS ARE IN MILLIMETERS.
2. DIMENSION "b" IS MEASURED AT THE MAXIMUM BALL DIAMETER AT THE PRIMARY DATUM "C".
3. THE BALL "A1" CORNER MUST BE IDENTIFIED IN THE INDICATED TOP PACKAGE SURFACE.
4. PRIMARY DATUM "C" AND SEATING PLANE ARE DEFINED BY CROWNS OF THE CONTACT SOLDER BALLS.
5. DIMENSION "A" DOES NOT INCLUDE ATTACHED EXTERNAL FERRITE BEAD, HEAT SINK OR CHIP CAPACITORS.
6. DIMENSION "A(MAX)" IS GIVEN FOR THE EXTREMELY THIN VARIATION OF DIMENSION "A". DIMENSION "A2" INCLUDES A DIE COATING THICKNESS.

DETAIL B

LAND PATTERN DIMENSIONS			
SYMBOL	MIN	NOM	MAX
D1/E1'	-	1.60	-
b'	0.20	0.20	-
e'	-	0.40	-

THE USER MAY MODIFY THE PCB LAND PATTERN DIMENSIONS, BASED ON THEIR EXPERIENCE AND/OR PROCESS CAPABILITY

PCB LAND PATTERN

Figure 9.1 25WLCSP, 2.0x2.0mm Body, 0.4mm Pitch

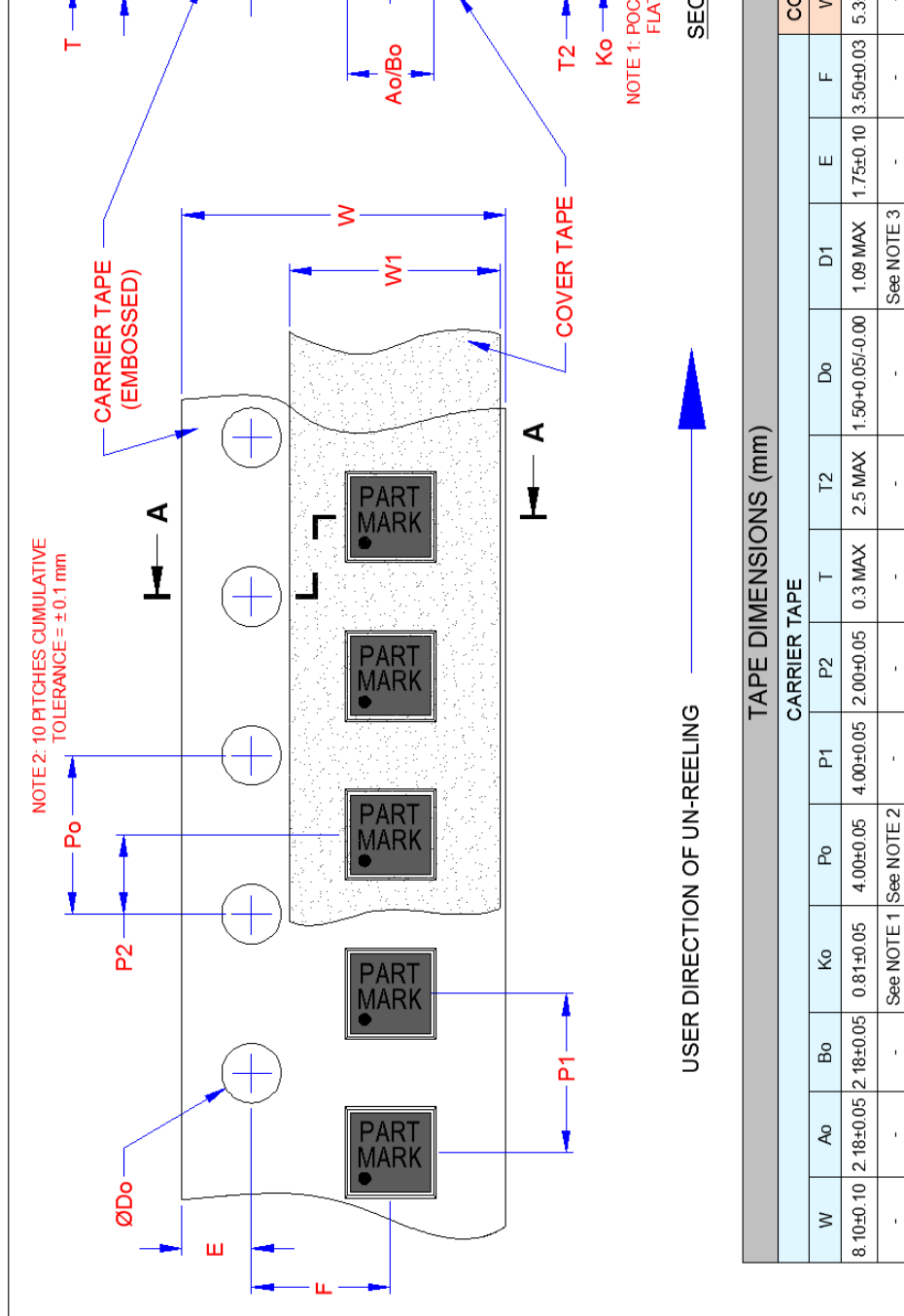

25DSe1-1.97x1.97mm: TAPE DIMENSIONS AND PART ORIENTATION

Figure 9.2 25WL CSP, 1.97x1.97 Tape and Reel

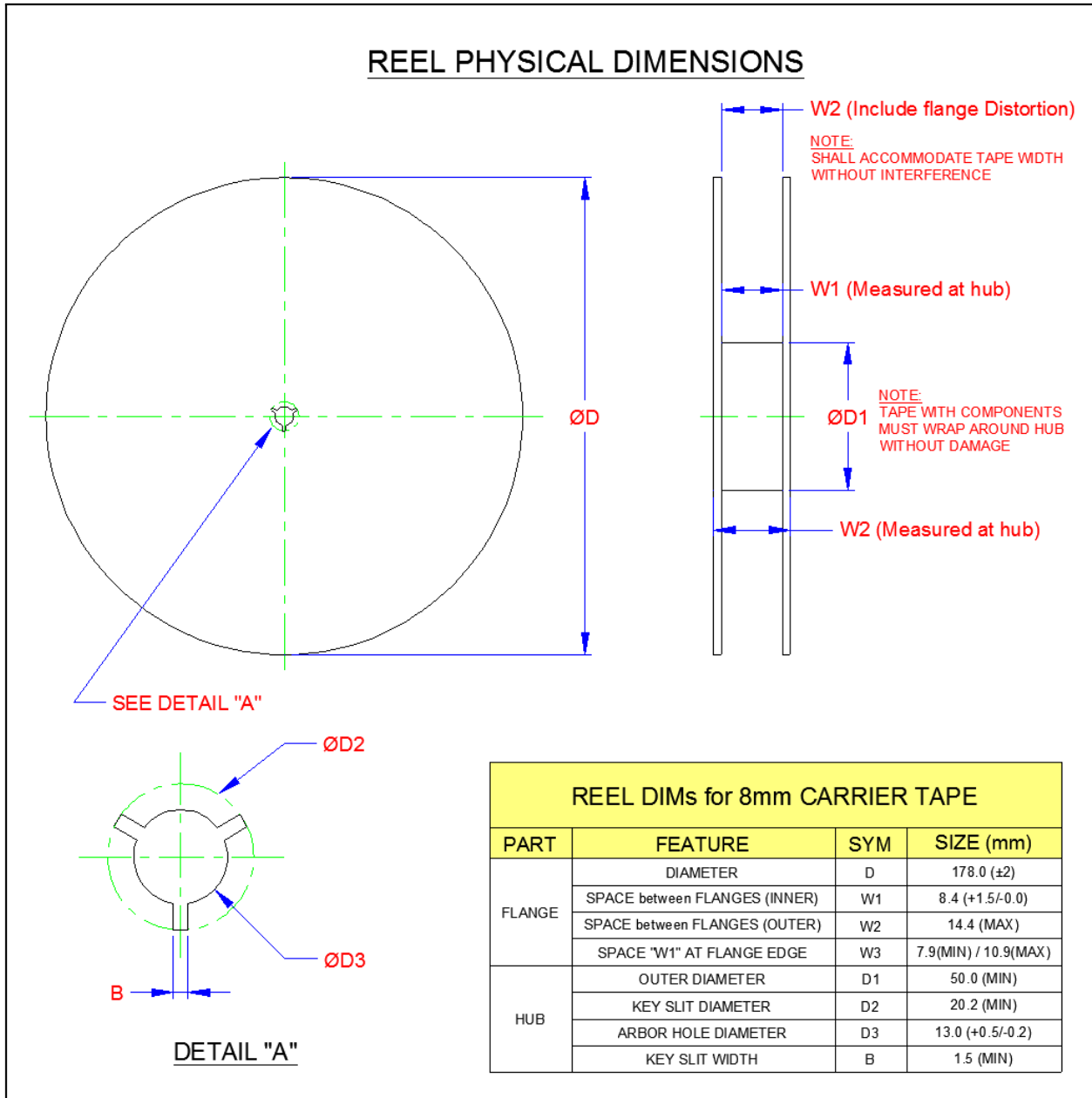

Figure 9.3 25WLCSP, 1.97x1.97 Reel Dimensions

Datasheet

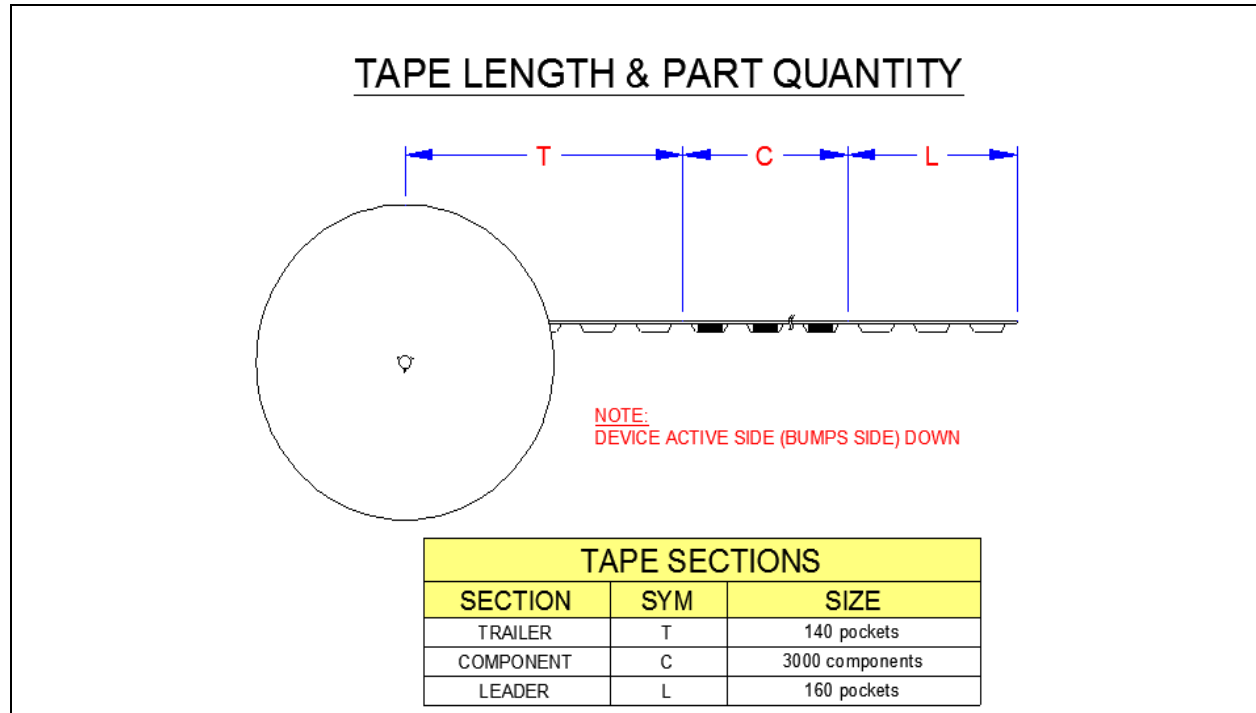

Figure 9.4 25WLCSP, 1.97x1.97 Tape Sections

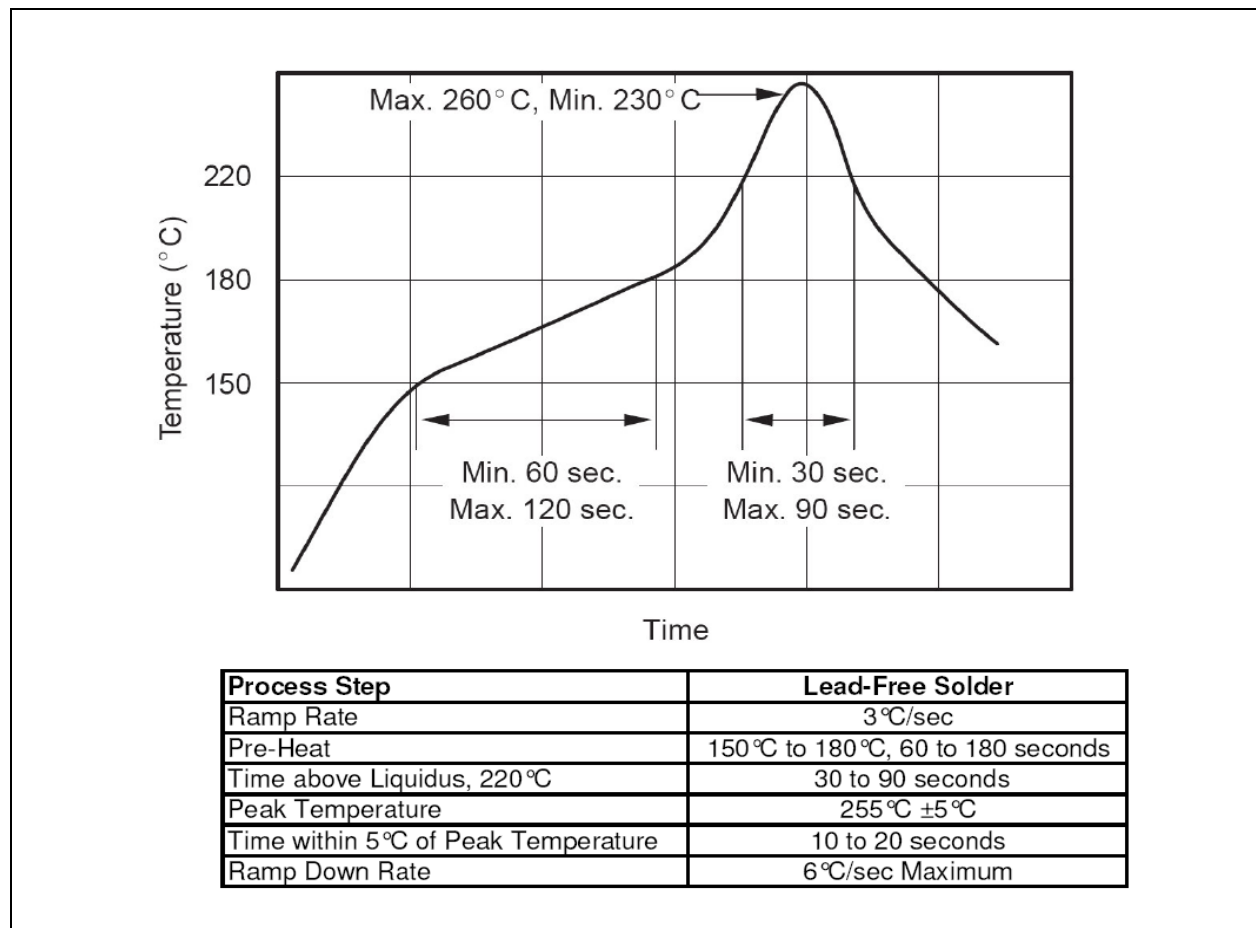

Figure 9.5 Reflow Profile and Critical Parameters for Lead-free (SnAgCu) Solder

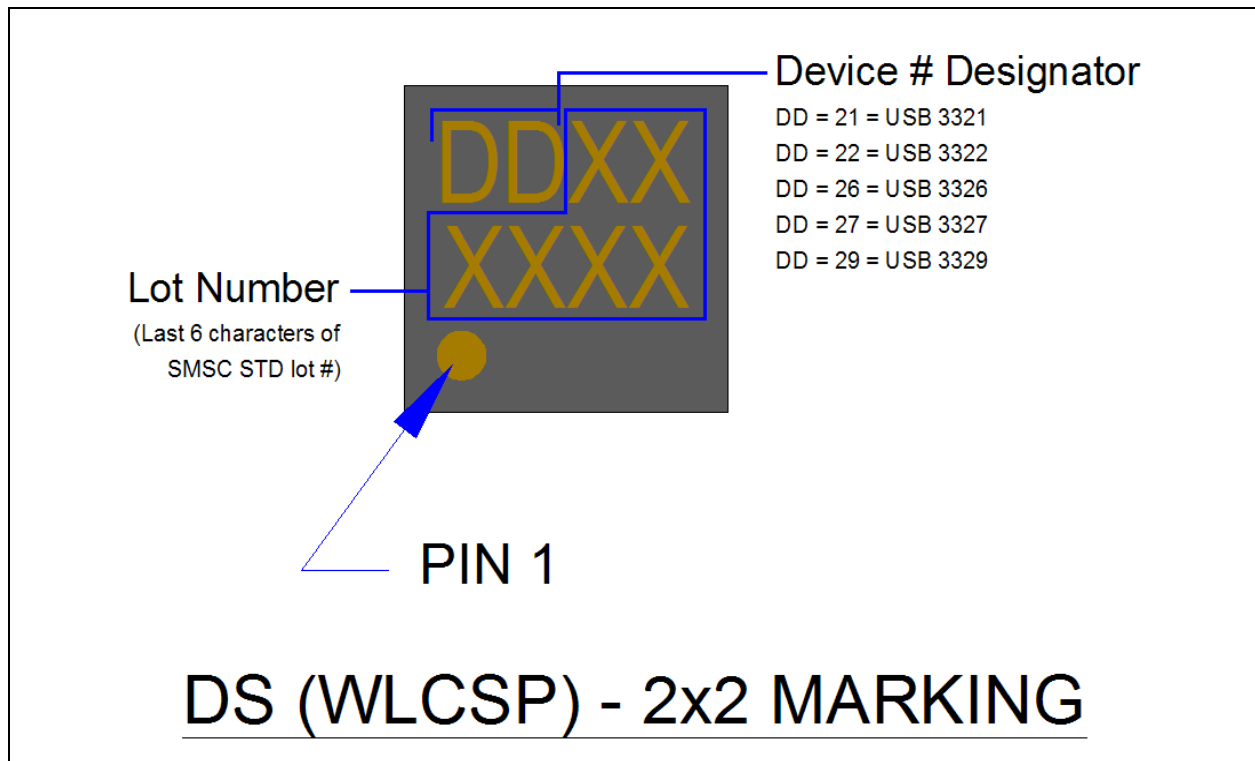

Figure 9.6 25WLCSP, 2x2 Package Marking

Chapter 10 Revision History

Table 10.1 Customer Revision History



REVISION LEVEL AND DATE	SECTION/FIGURE/ENTRY	CORRECTION
Rev. 1.1 (11-20-12)		Document co-branded: Microchip logo added; modification to legal disclaimer. Added to ordering information: "Please contact your SMSC sales representative for additional documentation related to this product such as application notes, anomaly sheets, and design guidelines."
Rev. 1.1 (03-31-10)	Chapter 9, Package Outline, Tape & Reel Drawings, Package Marking	<ul style="list-style-type: none"> Updated package drawings, tape and reel drawings.
Rev. 1.1 (09-02-09)	Table 4.1, "Operating Current", Table 4.3, "ULPI Interface Timing"	<ul style="list-style-type: none"> Updated values in Table 4.1 Modified note under Table 4.3
	Section 5.4	Added note that the system must not drive voltage on the CLKOUT pin following POR or hardware reset that exceeds the value of V_{IH_ED} provided in Table 4.4
	Section 8.1, "Application Diagram"	Added note that following POR or hardware reset, the voltage at CLKOUT must not exceed V_{IH_ED} as provided in Table 4.4
	Figure 5.7	Added schematic for case when VBAT is powered from VBUS.
	Table 4.5	Updated squelch spec and note regarding 200mV waiver.
	Table 4.3	Updated Tsc, Tsd 60MHz CLKIN spec to 1.5ns.
	Section 5.6.2.6	Updated resistor calculation location.
	Table 3.1 Table 3.2	Added notes that VDDIO should never fall below VDD18
	Table 5.2	Added note that VDD18 must be powered to tristate ULPI pins.
	Table 7.1 Section 7.1.3.2 Section 6.7	Added headset audio register to table. Added section on headset audio mode description, and how to enter and exit mode.
	Figure 5.9 Table 5.4 Table 6.3	Corrected IDGND comparator polarity, truth table, and references to IDGnd in RXCMD table.
Figure 9.6	Added device package markings.	
Order Numbers	Removed USB3324, USB3325, and USB3328 from product list.	
Rev. 1.0 (08-26-08)	Figure 8.2, "USB332x WLCSP Application Diagram (Host or OTG configured for ULPI Clock In mode)"	Replaced figure

Table 10.1 Customer Revision History (continued)

REVISION LEVEL AND DATE	SECTION/FIGURE/ENTRY	CORRECTION
Rev. 1.0 (08-26-08)	Section 8.2.2, "Detecting DP Shorted to DM"	Changed: "Enable ChargerPullupEnableDP resistor" to: "Enable ChargerPullupEnableDM resistor"
Rev. 1.0 (08-26-08)	Table 7.1, "ULPI Register Map"	Reserved register for 00h, address changed from "22-35h" to "22-30h" Added "Reserved" row 32-35h across
Rev. 1.0 (08-26-08)	Table 5.2, "Operating Mode vs. Power Supply Configuration"	Removed from table following "RESET Mode": "VDD18 Current <1uA" removed from note following table: "This column assumes the VBAT pin is powered as described above." added: ". . .per Table 3.2"
Rev. 1.0 (08-26-08)	Table 3.2, "Recommended Operating Conditions"	Removed "CPEN" from "Voltage on Analog I/O Pins" (Parameter column)
Rev. 0.5 (07-23-08)	Section 5.2.1, "USB Transceiver"	Added paragraph describing boost bit operation.
Rev. 0.5 (07-08-08)	Section Table 4.2, "ULPI Clock Specifications"	Added MIN value for T _{PREP} and corrected MAX value.
Rev. 0.5 (07-08-08)	Section 7.1.3.1, "HS TX Boost"	Boost Register added to support configuration of drive strength increase.
Rev. 0.5 (07-08-08)	Section 7.1.1.10, "USB Interrupt Status"	Correct ACCESS to remove the auto-clear notation.
Rev. 0.4 (06-25-08)	Table 4.1, "Operating Current"	Table values updated; conditions above table modified
Rev. 0.4 (04-08-08)	Section 8.2.1 "Detecting the ID Resistor in a Charger"	Pseudo Algorithm for detecting resistor to ground and reading value modified

Looking for pricing, stock, or lifecycle information?

Click below to explore more details on WIN SOURCE:

-  [View USB3326C-GL-TR on WIN SOURCE](#)
-  [Microchip Technology](#) Information

Optimize Your Supply Chain with WIN SOURCE Solutions

-  Global Sourcing Solution
-  Obsolete Management
-  Cost Control Management
-  Shortage Management
-  Alternative Solution
-  Excess Inventory Management